

# Attitude Determination & Control for University CubeSats – KISS (Keep It Simple, Students)

John Rakoczy

NASA MSFC

Alabama Space Grant Consortium CubeSat Workshop

November 9, 2018

# ADCS Architectures

|                        | Simple, inexpensive                    | Complex, expensive   |
|------------------------|--|--|
| Attitude Determination | Sun Sensor<br>Magnetometer<br>MEMS IMU | Sun Sensor4<br>Magnetometer<br>MEMS IMU<br>Star Tracker            |
| Attitude Control       | Magnetic torque rods                   | Magnetic torque rods<br>Reaction wheels<br>Reaction control system |
| Approximate cost       | < \$20K                                | \$200K-\$500K  |
| Pointing Accuracy      | > 5 degrees                            | < 1 degree   |

Your CubeSat has ejected from the launch vehicle.

What is the first thing it should do?

# Damp Tip-off Rates

- Find out from launch provider what rates (3 axes) to expect from ejection (typically  $\sim 5$  deg/sec or less)
- How do we damp the rates?
  - We can use a propulsion system (usually way too expensive for university cubesats)
  - Or, we can use reaction wheels (still expensive)
  - Or, we can use magnetic torque rods
    - Bdot control

# Earth is a big dipole magnet!

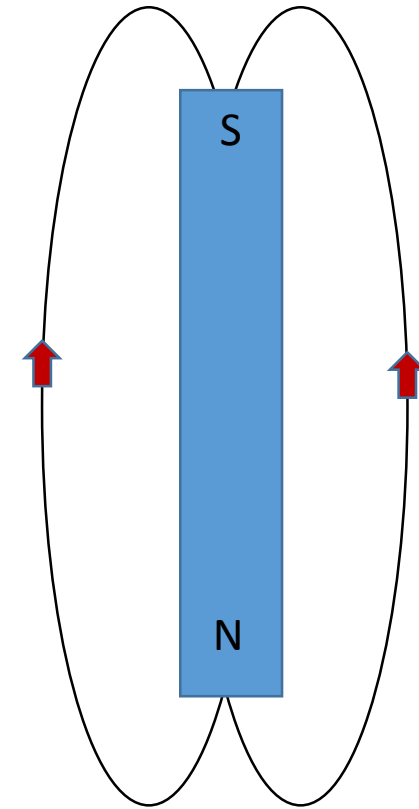
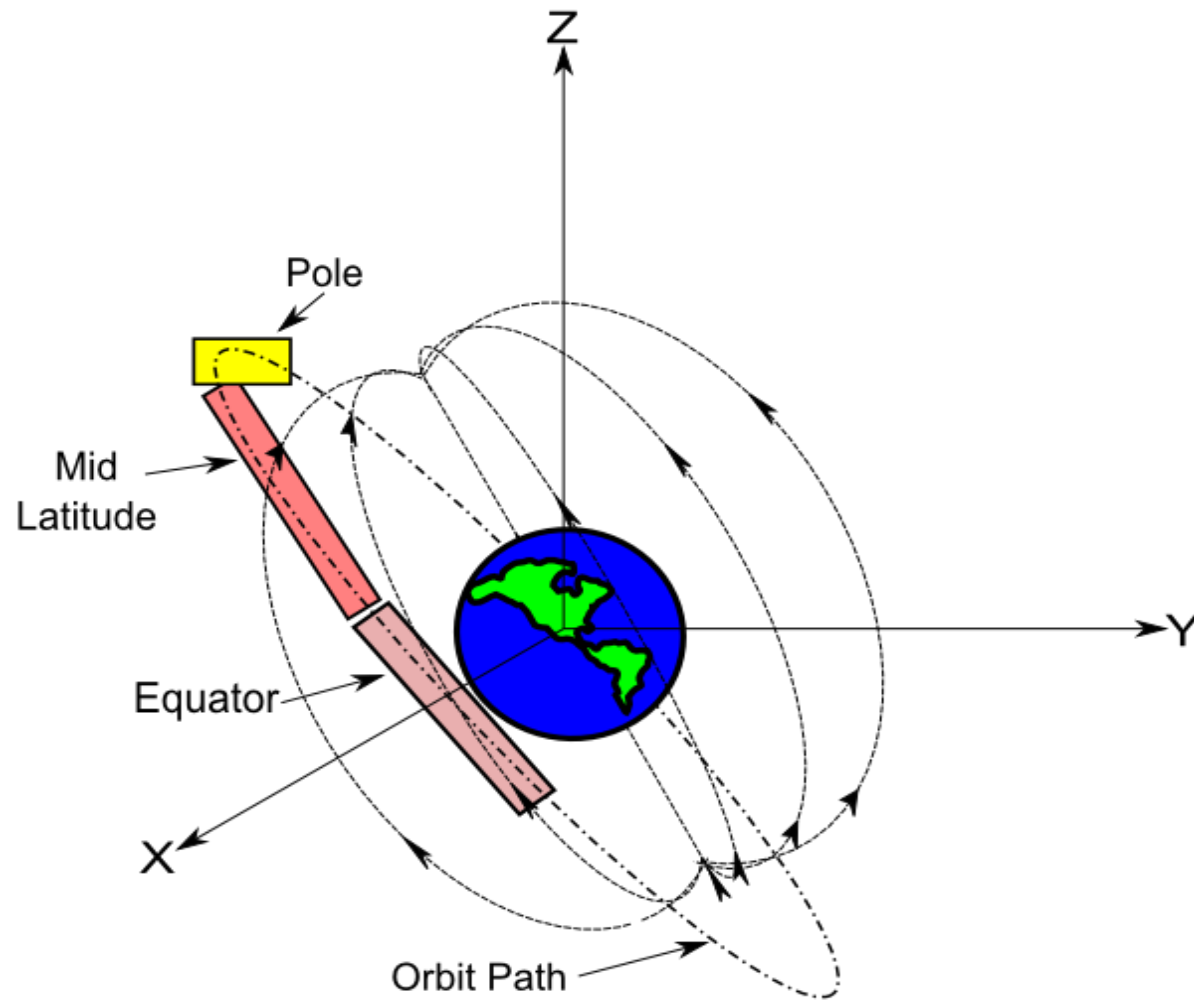

# Bdot Controller Example

$$\begin{bmatrix} \dot{B}_{Bx} \\ \dot{B}_{By} \\ \dot{B}_{Bz} \end{bmatrix} = \frac{1}{\Delta t} \begin{bmatrix} B_{Bx}(t) - B_{Bx}(t - \Delta t) \\ B_{By}(t) - B_{By}(t - \Delta t) \\ B_{Bz}(t) - B_{Bz}(t - \Delta t) \end{bmatrix}$$

$$\begin{bmatrix} M_x \\ M_y \\ M_z \end{bmatrix} = K \begin{bmatrix} -K_{11} & 0 & 0 \\ 0 & -K_{22} & 0 \\ 0 & 0 & -K_{33} \end{bmatrix} \begin{bmatrix} \dot{B}_{Bx} \\ \dot{B}_{By} \\ \dot{B}_{Bz} \end{bmatrix}$$

$$K = 50,000$$

$$K_{11} = K_{22} = K_{33} = 900$$

$$\Delta t = 10 \text{ seconds}$$



# Magnetic Torque Rod Actuation

$$\vec{T} = \vec{M} \times \vec{B}$$

$$\vec{M} = \mu N I A \vec{n}$$

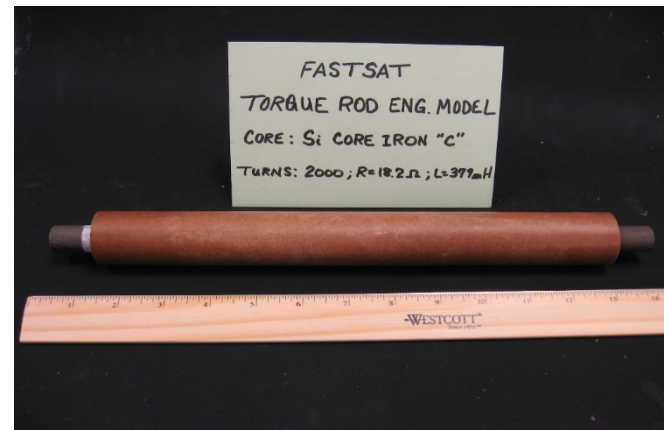

Body angular rates during Bdot tip-off damping

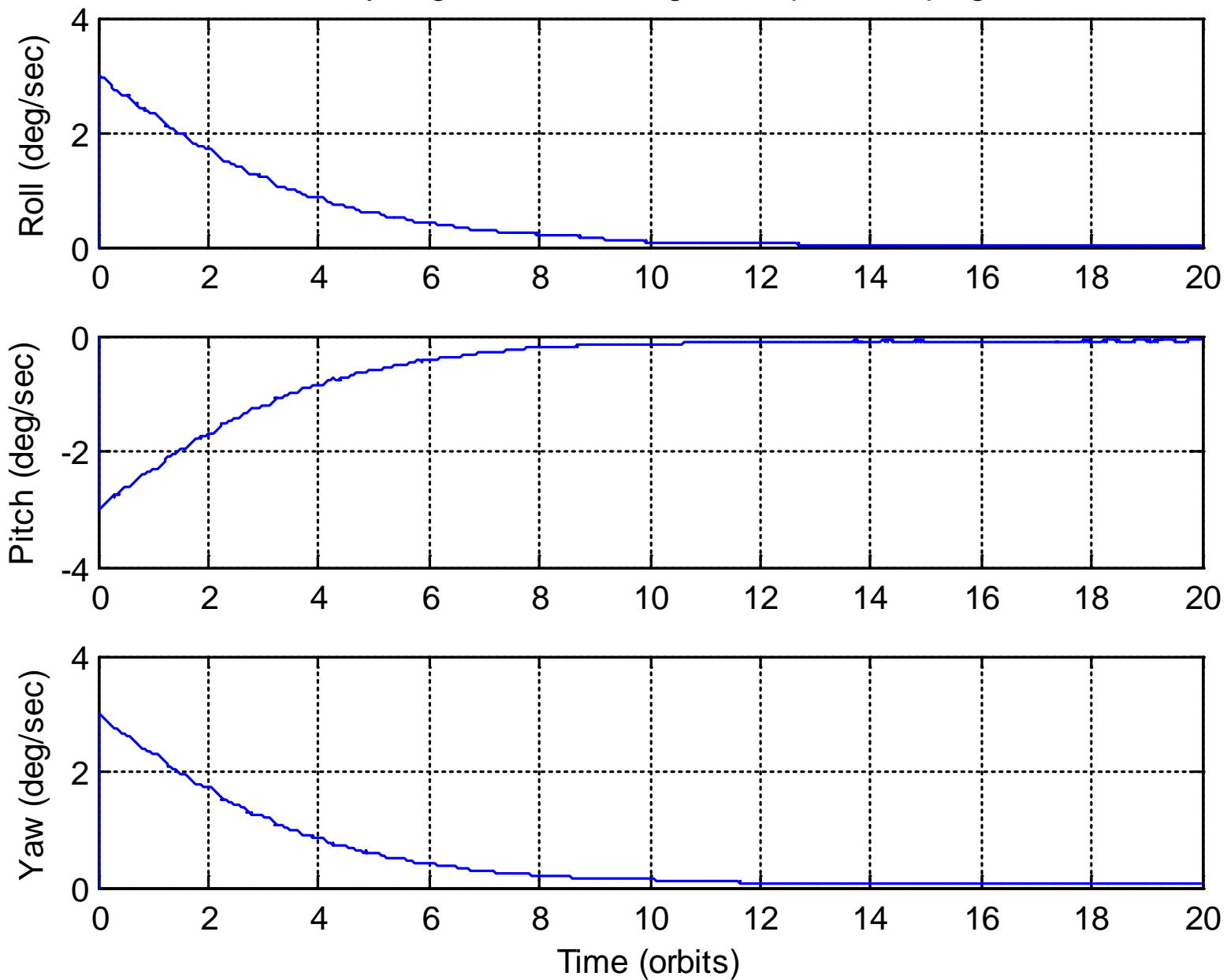



Body angular rates during Bdot tip-off damping

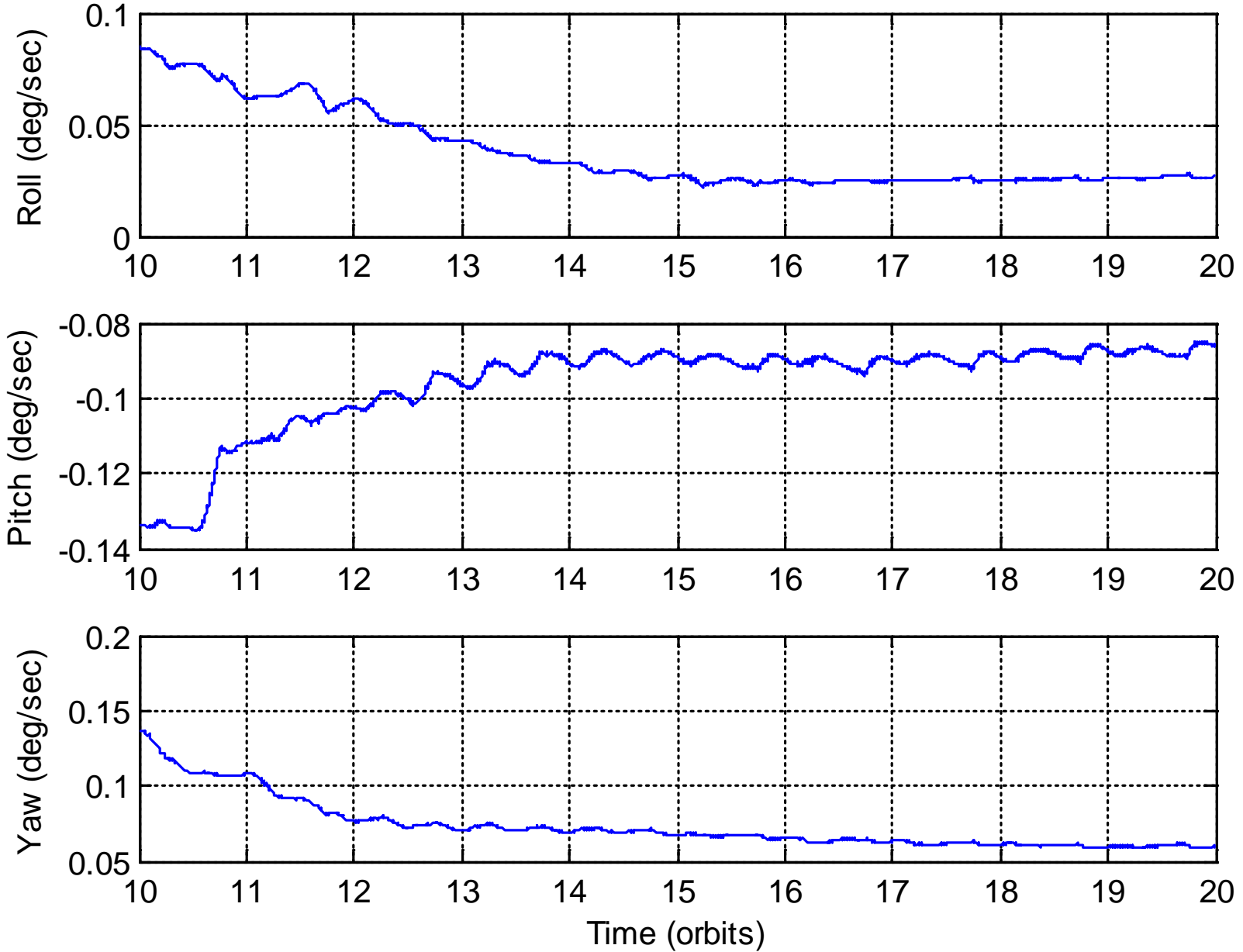

# Why does Bdot work so well?

Because Bdot is proportional to the angular rate of the vehicle

So it behaves like derivative control (a damper) – it's always stable!

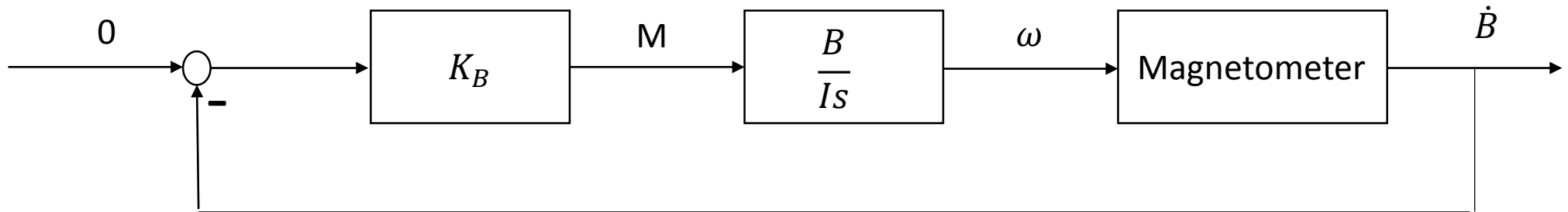

We get exponential decay with time constant proportional to  $K_B B / I$

Limitation: Bdot control will only get angular rates down to 2 revs/orbit

# Or Use Miniature Reaction Wheels (if you can afford them)

$$H_{wheel} > I_{vehicle} \omega_{tip-off}$$

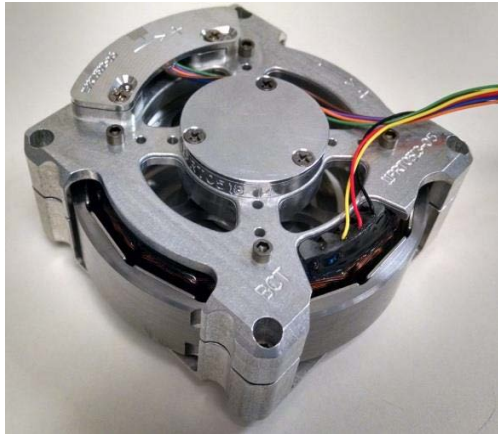

Blue Canyon Technologies Mini Reaction Wheel

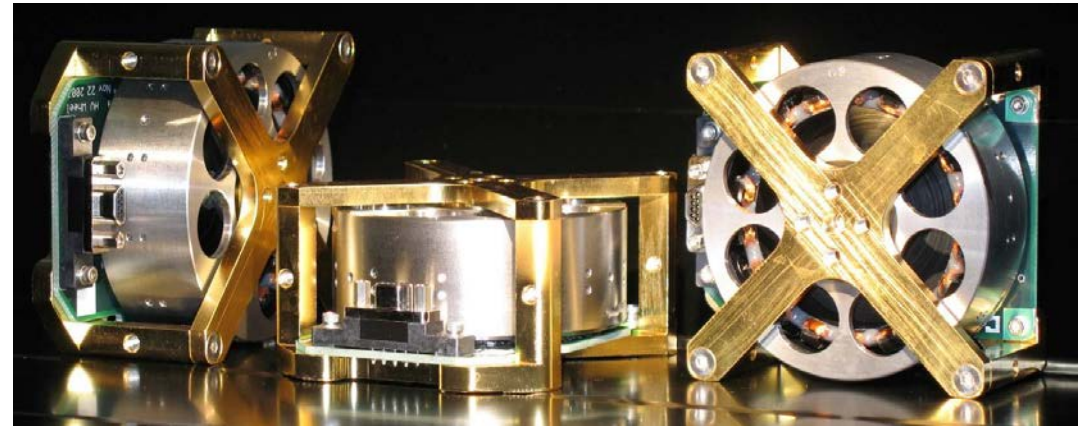

Sinclair Interplanetary Mini Reaction Wheels

What do we do next?

# Find the Sun!



Sun Sensors from Sinclair Interplanetary

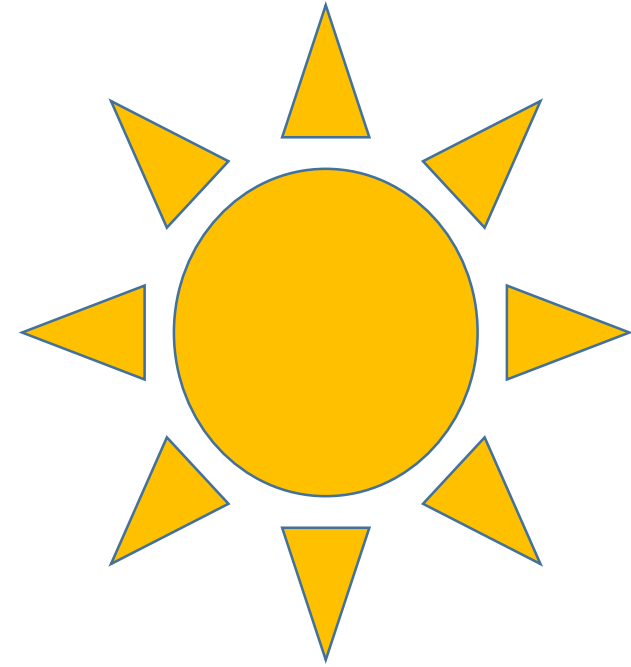

And figure out where the heck we're pointed

# Attitude Estimation

## TRIAD Technique

$\vec{S}_m$  = measured sun vector

$\vec{B}_m$  = measured magnetic field vector

$\vec{S}_r$  = reference sun vector

$\vec{B}_r$  = reference magnetic field vector

$$\vec{M}_1 = \vec{S}_m$$

$$\vec{M}_2 = \vec{M}_1 \times \vec{B}_m / \|\vec{M}_1 \times \vec{B}_m\|$$

$$\vec{M}_3 = \vec{M}_1 \times \vec{M}_2$$

$$\vec{R}_1 = \vec{S}_r$$

$$\vec{R}_2 = \vec{R}_1 \times \vec{B}_r / \|\vec{R}_1 \times \vec{B}_r\|$$

$$\vec{R}_3 = \vec{R}_1 \times \vec{R}_2$$

$$T_{B,I} = \begin{bmatrix} \vec{M}_1 & \vec{M}_2 & \vec{M}_3 \end{bmatrix} \begin{bmatrix} \vec{R}_1 & \vec{R}_2 & \vec{R}_3 \end{bmatrix}^T$$

# Extract attitude quaternion from DCM

$$T_{B,I} = \begin{pmatrix} q_1^2 - q_2^2 - q_3^2 + q_4^2 & 2(q_1q_2 + q_3q_4) & 2(q_1q_3 - q_2q_4) \\ 2(q_1q_2 - q_3q_4) & -q_1^2 + q_2^2 - q_3^2 + q_4^2 & 2(q_2q_3 + q_1q_4) \\ 2(q_1q_3 + q_2q_4) & 2(q_2q_3 - q_1q_4) & -q_1^2 - q_2^2 + q_3^2 + q_4^2 \end{pmatrix}$$

$$q_1 = e_1 \sin \frac{\theta}{2}$$

$$q_2 = e_2 \sin \frac{\theta}{2}$$

$$q_3 = e_3 \sin \frac{\theta}{2}$$

$$q_4 = \cos \frac{\theta}{2}$$

$\theta$  is the eigenangle

$\begin{pmatrix} e_1 \\ e_2 \\ e_3 \end{pmatrix}$  is the eigenaxis

Formulas for extracting quaternions from the DCM may be found in any good Spacecraft attitude dynamics and control textbook

# TRIAD Attitude Estimation Accuracy Example

| Sun Vector<br>Uncertainty (3-<br>sigma) | Mag Field Vector<br>Uncertainty (3-<br>sigma) | Attitude<br>Estimation Error<br>(1-sigma) |
|---|---|---|
| 1 deg                                   | 10 deg  | 2 deg                                     |
| 1 deg                                   | 15 deg  | 3 deg                                     |
| 1 deg                                   | 20 deg  | 4 deg                                     |



# Single-vector Attitude Estimation

(if you're really poor and can only afford one sensor)

$$\vec{V}_1 = \vec{V}_B$$

$$\vec{V}_2 = \vec{V}_{ref}$$

$$\phi = \sin^{-1}((\vec{V}_1 \times \vec{V}_2) / (\|\vec{V}_1\| \bullet \|\vec{V}_2\|)), \text{ the eigen angle}$$

$$\vec{e} = (\vec{V}_1 \times \vec{V}_2) / \|\vec{V}_1 \times \vec{V}_2\|, \text{ the eigen axis}$$

$$\begin{bmatrix} q_1 \\ q_2 \\ q_3 \end{bmatrix} = \begin{bmatrix} e_1 \sin(\phi/2) \\ e_2 \sin(\phi/2) \\ e_3 \sin(\phi/2) \end{bmatrix}$$

$$q_4 = \sqrt{1 - q_1^2 - q_2^2 - q_3^2}$$

\*\*\* Single-vector technique works only with other means of angular rate estimation \*\*\*

This method gives a crappy attitude estimate

# Accurate Attitude Estimation – Star Trackers

| Axis                 | Accuracy        |
|----------------------|-----------------|
| Pitch/Yaw            | < 10 arcseconds |
| Roll about Boresight | < 50 arcseconds |

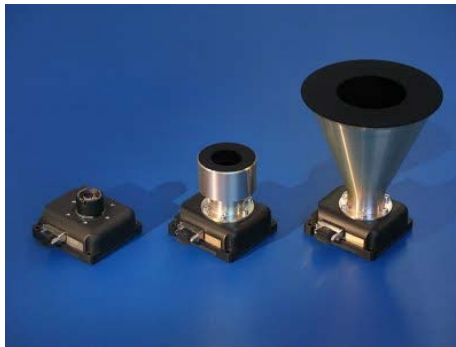

Sinclair Interplanetary Mini Star Trackers

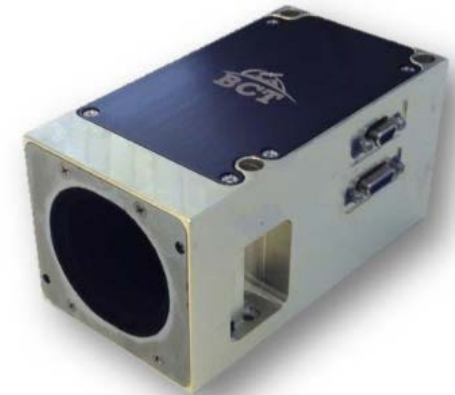

Blue Canyon Technologies Mini Star Tracker

# Or use a Kalman Filter

- Uses the sensors previously discussed to give an improved attitude estimate.
- Can also estimate biases in the inexpensive MEMS rate gyros
- I won't cover this topic today. It's usually a whole semester graduate course. There are a lot of good papers out there for the bright, motivated undergraduate.

# Angular Rate Estimation from Quaternion

(If you're so poor you can't afford MEMS rate gyros)

$$\hat{\omega} = \frac{2}{\Delta t} \begin{bmatrix} q_4(t - \Delta t) & q_3(t - \Delta t) & -q_2(t - \Delta t) & -q_1(t - \Delta t) \\ -q_3(t - \Delta t) & q_4(t - \Delta t) & q_1(t - \Delta t) & -q_2(t - \Delta t) \\ q_2(t - \Delta t) & -q_1(t - \Delta t) & q_4(t - \Delta t) & -q_3(t - \Delta t) \end{bmatrix} \begin{bmatrix} q_1(t) - q_1(t - \Delta t) \\ q_2(t) - q_2(t - \Delta t) \\ q_3(t) - q_3(t - \Delta t) \\ q_4(t) - q_4(t - \Delta t) \end{bmatrix}$$

$q(t)$  is the current quaternion estimate

$q(t - \Delta t)$  is the quaternion estimate from the last sample interval

$\Delta t$  is the angular rate estimation sample interval, nominally 1.0 seconds

$\hat{\omega}$  is the angular rate estimate in the body - frame

But this rate estimate will be very crappy if your quaternion estimate isn't very good

\*\*\*\*\*Differentiation is an inherently noisy process\*\*\*\*\*

We found the Sun!

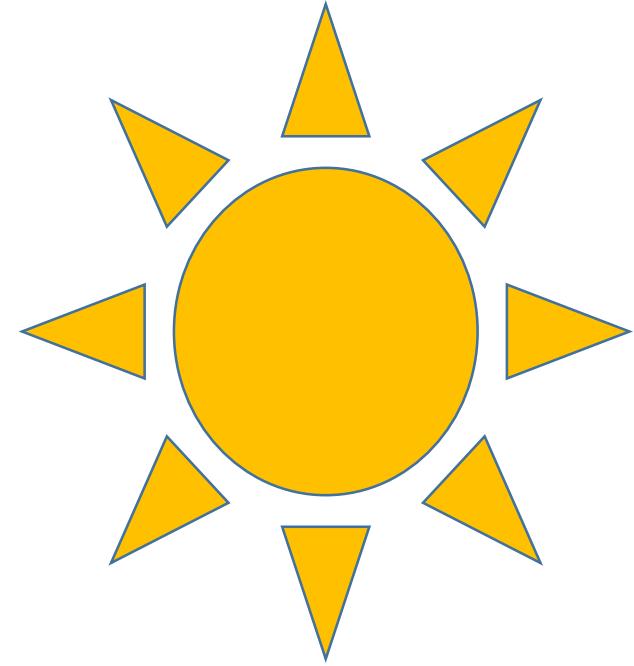

Now let's point toward it!

# Maneuvers

## Classical “Bang-off-Bang” control

Commanded Angle

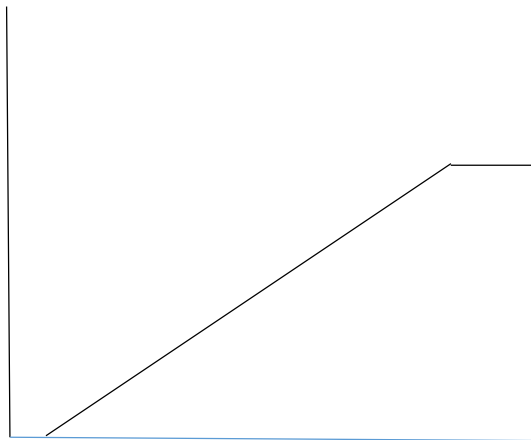

time

Commanded Angular Rate

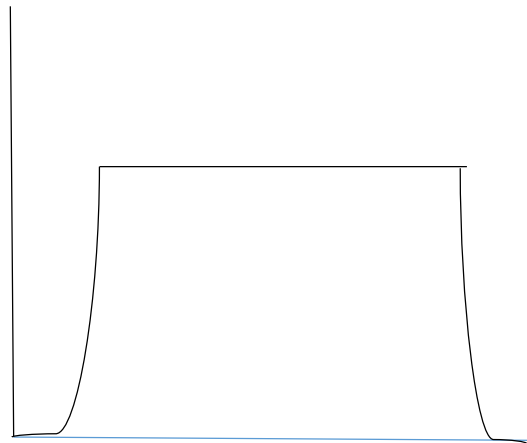

time

Commanded Torque

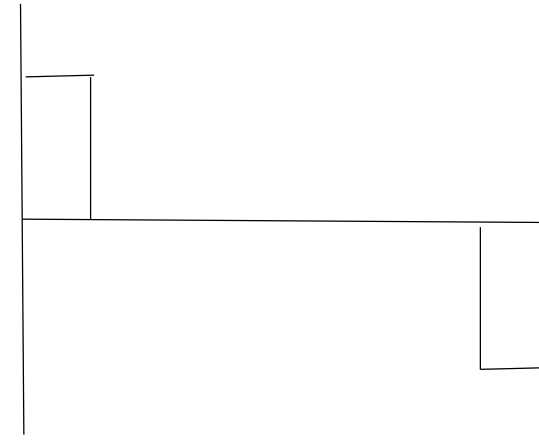

time

# Maneuver Considerations

if you're using reaction wheels for the maneuver, size your wheels so that

$$H_{wheel} > I_{vehicle} \omega_{commanded}$$

$$T_{wheel} > T_{commanded}$$

if you're using magnetic torque rods for the maneuver, just be patient.

It might take a while, but you'll eventually get there.

You'll also have to consider torque rod limitations (see later slide)

Now let's hold an attitude!



# Different kinds of attitudes

- Inertial – point to a spot on the celestial sphere
  - Toward a star for a telescope science mission
  - Toward the sun to charge batteries
- Nadir pointing (or LVLH Local Vertical Local Horizontal) – always point down toward the earth
  - A target on earth for earth science observations
  - A ground station for data transmission
- Or if we don't have any money and don't care about our attitude, we can stick a magnet in the spacecraft and let it rotate 2 revolutions per orbit.

# Attitude Control (PD control)

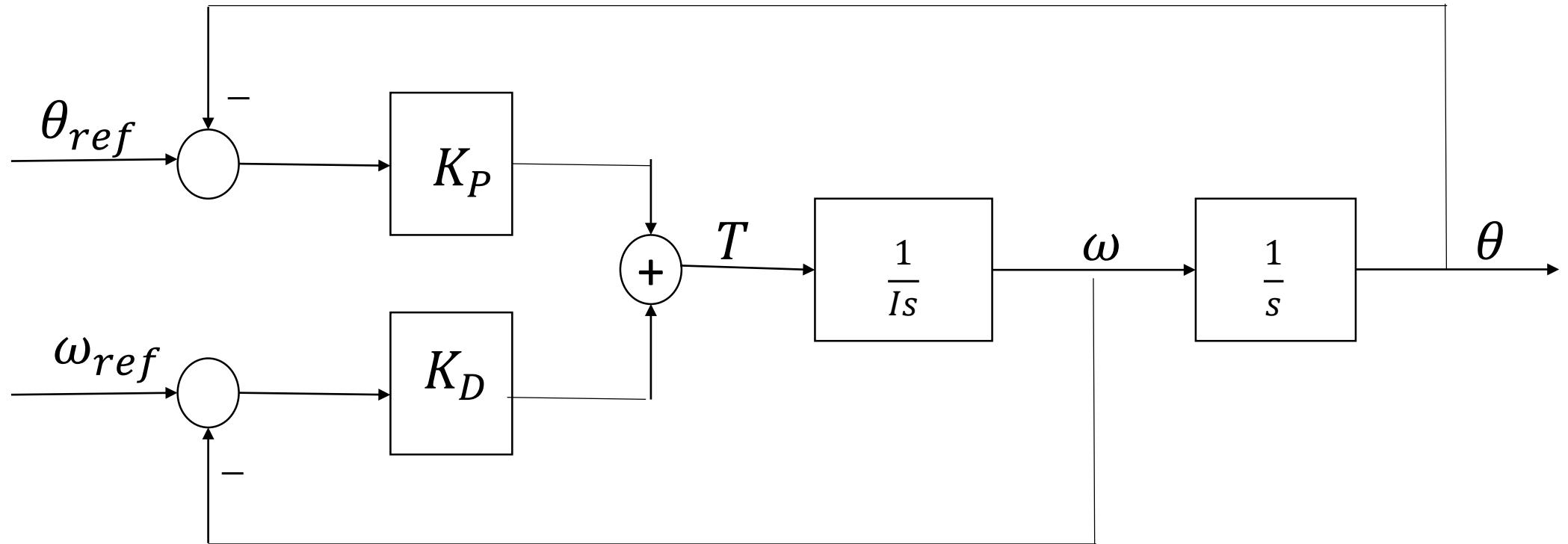

Characteristic equation:  $I\ddot{\theta} + K_D\dot{\theta} + K_P\theta = 0$

$K_P$  is like a spring ("proportional")  
 $K_D$  is like a damper ("derivative")

# Gravity Gradient Torque & Stabilization

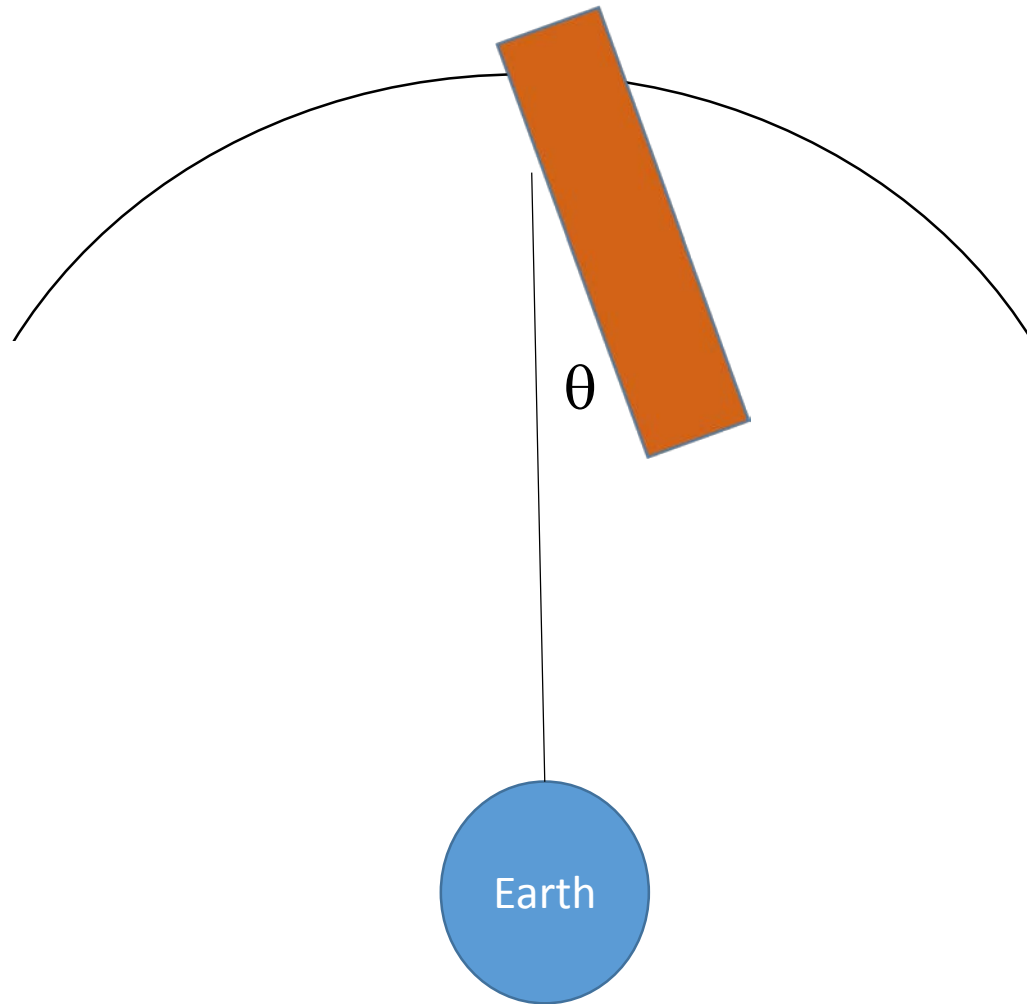

$$I_{pitch}\ddot{\theta} + 3\frac{\mu}{R^3}(I_{yaw} - I_{roll})\sin\theta\cos\theta = 0$$

Linearized for small angles:

$$I_{pitch}\ddot{\theta} + 3\frac{\mu}{R^3}(I_{yaw} - I_{roll})\theta = 0$$

Which looks a lot like the linearized pendulum equation:

$$I_{pitch}\ddot{\theta} + \frac{g}{L}\theta = 0$$

Don't be fooled by the apparent linear stability.  
This is nonlinear and can behave unpredictably.

How do we ensure stability?

# Add Damping to Supplement Gravity Gradient Stabilization

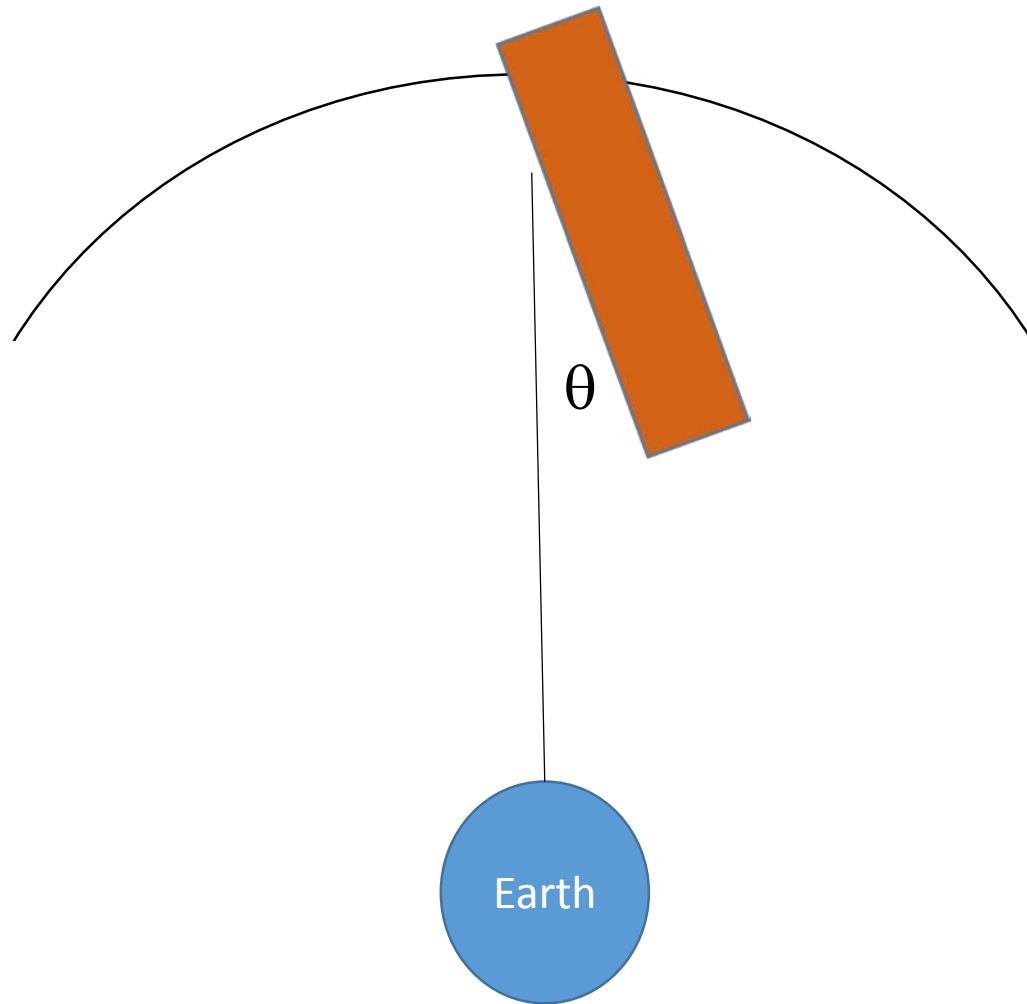

$$I_{pitch}\ddot{\theta} + 3\frac{\mu}{R^3}(I_{yaw} - I_{roll})\sin\theta\cos\theta = 0$$

Linearized for small angles:

$$I_{pitch}\ddot{\theta} + 3\frac{\mu}{R^3}(I_{yaw} - I_{roll})\theta = 0$$

- Use torque rods in an angular rate feedback loop, or
- Recall Bdot control behaves like derivative control and adds damping

$$I_{pitch}\ddot{\theta} + KK_B\dot{\theta} + 3\frac{\mu}{R^3}(I_{yaw} - I_{roll})\theta = 0$$

$$I_{pitch}\ddot{\theta} + K_D\dot{\theta} + 3\frac{\mu}{R^3}(I_{yaw} - I_{roll})\theta = 0$$

# Momentum Bias Control

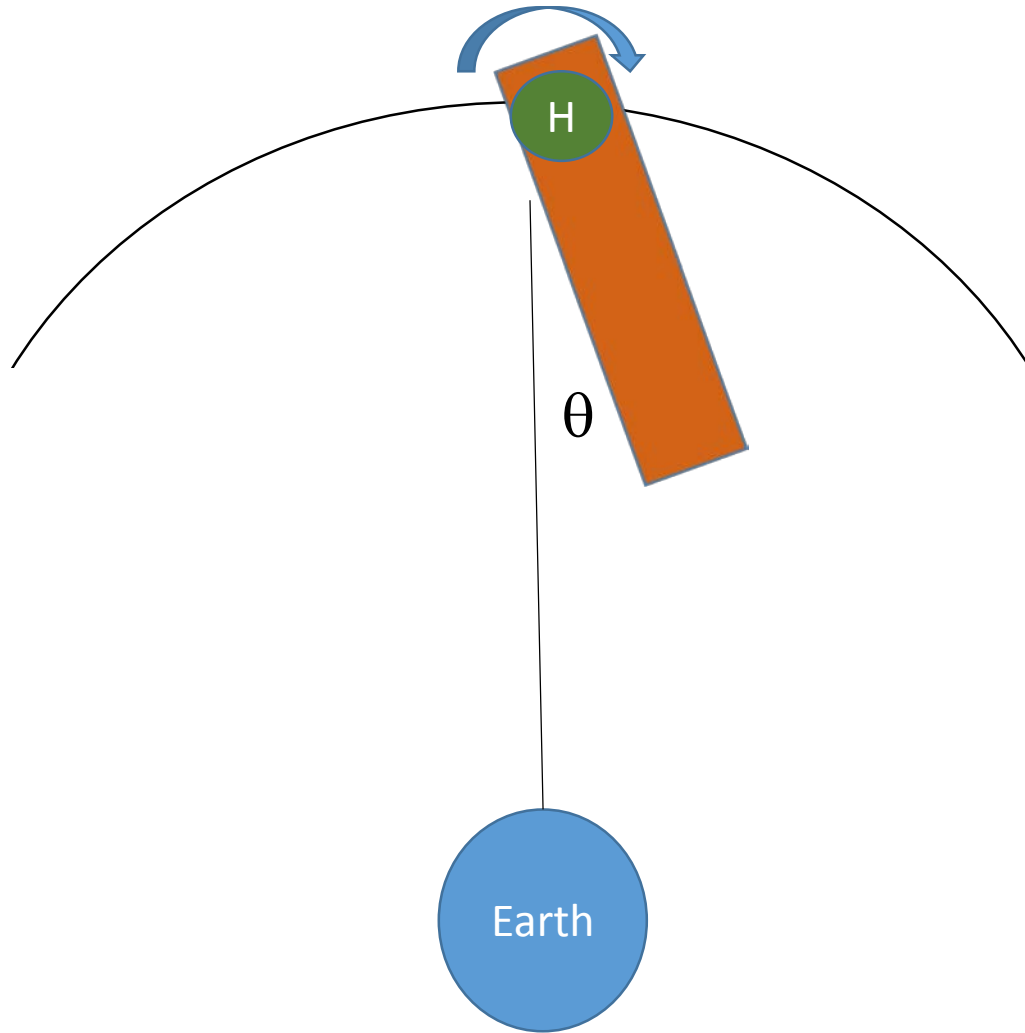

- Supplement gravity gradient stabilization with momentum bias
- Use a single reaction wheel and spin it up
- Provides fine control in pitch axis
- Provides gyroscopic stiffness and passive stability in roll and yaw

# Three-axis control

## Reaction Wheels

- One wheel per axis can point anywhere (inertial or LVLH)
- Can accommodate high-bandwidth control requirements
- You must manage momentum via propulsion or magnetic torque rods – don't let wheels saturate

## Magnetic torque rods

- Can only control 2 axes at any given time
- Works best for LVLH in polar orbits
  - Always have pitch control
  - Yaw and roll control alternate
- Less effective for inertial attitudes or equatorial orbits
- Very low bandwidth (slow response time ~ tens of minutes up to orbits)

# Magnetic Torquer Control Limitations

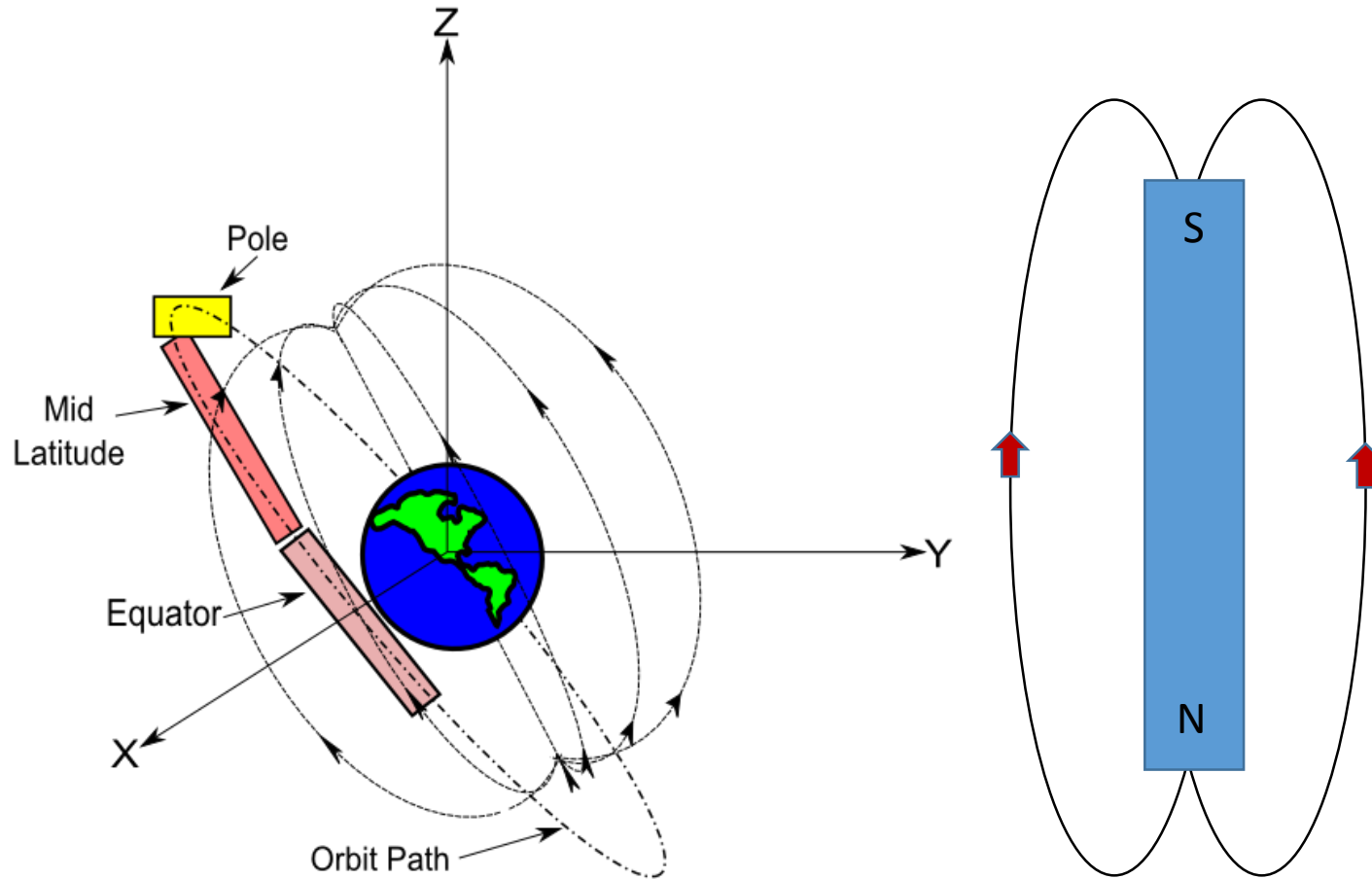

- When I apply torque in one axis, I also get torque in another axis.
- In equatorial orbits, field lines are always close to the same direction- won't get torque in one axis for LVLH attitudes.
- In inertial attitudes, environmental torques might exceed your magnetic torque authority – so make sure you size your torquers appropriately.

# Environmental Disturbance Torques

- Gravity Gradient
- Aerodynamic
- Magnetic
- Solar Radiation Pressure

Evaluate these disturbance torques to size your control actuators.

All of these can be a friend or foe, depending on the attitudes you're required to fly.

The *Space Mission Analysis and Design (SMAD)* book or any good spacecraft attitude dynamics book has the equations



# Navigation

- You need to know where you are
  - For specific pointing and tracking objectives (especially for nadir targets and ground station telemetry passes)
  - To use TRIAD attitude estimation with magnetometer and sun sensor
- Use a GPS and/or IMU in a navigation filter (a Kalman filter)
- If you lose GPS, the navigation filter will be satisfactory for several days until error propagation gets too large
  - One could obtain orbital elements via ground calculations, uplink them, and let navigation filter propagate them

# Some Rules of Thumb

1. Attitude determination accuracy should be 10x better than attitude control requirement
2. Sensor and actuator bandwidth should be 10x higher than control bandwidth
3. In preliminary design, size your control actuators to have 2x the control authority than your mission requires

# Other Considerations

- GN&C/ADCS engineers often become the *de facto* system engineers of a spacecraft project.
- GN&C/ADCS engineers are at the center of the following:
  - Science payload pointing
  - Pointing solar arrays toward the sun to charge batteries for power system
  - Pointing antennas toward ground stations for telemetry and ground commands
  - Orient spacecraft to maintain thermal environment
  - Propulsion system sizing
  - C&DH system specification