

A NEURAL NETWORK BASED RESPONSE MODEL FOR HIGH VOLTAGE CIRCUIT-BREAKER TESTING

Wesley DOORSAMY, Pitshou BOKORO

Department of Electrical and Electronic Engineering Technology, University of Johannesburg,
PO Box 17011, Doornfontein, South Africa

wdoorsamy@uj.ac.za, pitshoub@uj.ac.za

DOI: 10.15598/aeec.v16i3.2845

Abstract. Innovative test methods for circuit breakers are constantly sought after to reduce maintenance time and costs, yet still provide accurate assessment of this critical substation equipment. This paper proposes a novel method for response modelling of high voltage SF₆ circuit breakers, based on artificial neural networks, to provide a means of assessing its condition. The proposed method enables a timing response model of the circuit breaker to be developed using trip command parameters. In this paper, an experimental setup is used to perform trip response testing of a three-phase 75 kV circuit breaker. The obtained data is then used to train, validate and test a Bayesian regularised artificial neural network that can predict response times of the breaker for a given set of trip command parameters.

Keywords

Circuit breaker, condition assessment, neural network, response model.

1. Introduction

Maintenance and reliability of power system equipment have become increasingly important with growing electricity demand and ageing of system components globally [1]. In particular, circuit breakers are critical components of a power system performing protective and operational functions in the transmission and distribution categories. Therefore, effective monitoring and assessment techniques for ensuring the reliability of circuit breakers are important factors in the maintenance of modern power systems [2]. Failures of high voltage SF₆ circuit breakers have been studied extensively, and provide a means of modelling reliability of this equipment thereby affording predictive maintenance

measures. While model-based methods for assessing circuit-breaker condition have been proposed there are many drawbacks to these methods which are discussed in this paper. A key drawback with existing model-based methods is the use of historical statistical data which only partially reflects the ageing process but cannot accurately determine the actual circuit breaker condition [3]. Condition measurements are better suited to assessment but these are only meaningful when compared to an existing reference. However, these references are also based on a model or historical measurements. The variation in test conditions and operating cycles of circuit breakers can render comparative methods inaccurate or invalid. This research proposes a method for response modelling of high voltage circuit breakers. In this way, the response of the breaker at a past healthy state can be compared to its current state under the same test conditions. This paper presents a method for developing the response model, using an Artificial Neural Network (ANN), for a high voltage SF₆ circuit breaker which can be used to assess its condition.

2. Circuit Breaker Condition Assessment

There are different modes of failure for electrical equipment of a power system influenced by electrical, thermal, mechanical and ambient stresses [4]. These factors, through different mechanisms, produce varying intensity and progress of ageing change to the equipment [5]. The same applies to circuit breakers where complete failure may be defined as causing the lack of one or more of its fundamental functions [6].

High-voltage circuit breakers are broadly classified according to insulation type. SF₆ is the most common type used, but it also has a significantly lower aver-

age life than others, such as minimum oil and air-blast breakers [7]. The majority of failures in SF₆-type circuit breakers observed in the field are due to mechanical problems followed by insulation problems [2] and [7].

A good indicator of circuit-breaker condition is its switching time as it has been found to be influenced by critical irregularities with the device to the extent that relationships between such anomalies and the timing have been derived [8] and [9]. In [8], a reference timing is compared with the timing obtained after the breaker exhibits unusual operation. Analysis of the difference between these timings provides a means of detecting problems with the device. Although the modality employed by this method provides a useful means of assessing circuit-breaker condition, the timings used are compound and are vulnerable to variations in test conditions. More specifically, variations in the input signal/s to the device under test and environmental conditions directly influence the response time thus affecting the reference used by the method presented in [8]. Furthermore, the additional complexities, expense and inherent error of this methodology implore its augmentation in order for practical implementation. The proposed technique builds on the timing modality for condition assessment and accounts for the variations in test conditions and compound nature of circuit breaker switching times. The modelling of circuit-breaker response timing comprising these aforementioned complexities is afforded through the use of ANN. ANN has become more popular in the area of power engineering with applications in forecasting [10] and [11] and condition assessment problems [12].

Modern model-based circuit-breaker condition assessment techniques are becoming more popular in recent times. This is because model-based methods typically can be used irrespective of the maintenance strategy - i.e. timeor condition-based [5]. The probabilistic methodology presented in [13] is an example of a model-based method which offers a means of quantifying the effect of device maintenance for circuit breakers. This is achieved through the use of Bayesian updating of predetermined performance indices based on historical condition data. It should be highlighted that once again time-based responses of the circuit breaker are used as the key parameters for assessing condition thereof. Although, the Bayesian approach presented in [13] is quite useful, there are the drawbacks of the complexity involved with creating tolerance limits for the performance indices as well as obtaining suitable historical data. The end-of-life assessment of circuit breakers is of great interest to utilities and there are number of reliability model-based methods that have been proposed [1]. However, the historical data used with these types of models are prone to error result-

ing from variations in operating cycles and conditions of circuit breakers. The presented ANN-based method overcomes these drawbacks as it does not require historical data and embeds model complexity in the neural network. Moreover, it can be used in conjunction with reliability model-based methods. The proposed method provides a means of response modelling, therefore a comparative assessment of multiple circuit breakers under similar input conditions can be carried out to ensure accuracy of a particular reliability model.

3. Methodology

3.1. Circuit Breaker Timing Tests

There are various types of timing tests that may be performed on circuit breakers [8]. The timing test used in this work is commonly referred to as a contact speed timing test. This is a specialised test whereby a DC current signal is directly injected into the trip coil of the circuit breaker causing its main contacts to open. The injected current and the response times of the breaker are then recorded.

For this study, the contact speed timing test is performed on a 72.5 kV three-phase SF₆ high voltage circuit breakers. A Switch Analyser (SA10) is used to perform the test in the experimental configuration shown in Fig. 1. This device consists of 12 × 2 main contact timing channels, 6 auxiliary contact channels, 3 analogue and 3 digital transducer inputs and serial communication to an external computer. The circuit breaker under test is connected such that the links to the Switch Analyser and the test circuit earth loop are established.

3.2. Response Modelling

The timing test essentially consists of an input to the circuit-breaker system and an output or response. The three main contact times constitute the circuit breaker's response in this case. This response can be used as a reference in condition-based assessment as previously described. However, since the response is not only dependent on the circuit breaker's condition but also on the environmental conditions and variation in the injected signature (input), a reference timing alone will not suffice. Therefore, an actual response model of the circuit breaker is preferred. ANN is used to construct a response model that will capture the condition of the circuit breaker under test for a specific input signature. This model will then be able to output the main contact response times for other input signatures making it possible to accurately monitor deviation in response times, and hence condition, of

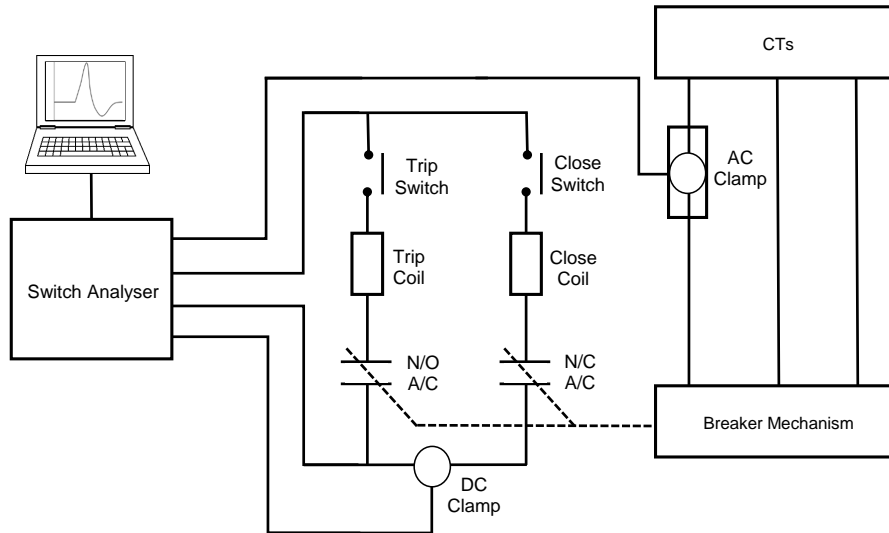

Fig. 1: Experimental setup used for conducting circuit breaker timing tests.

the circuit breaker. The response model is created by

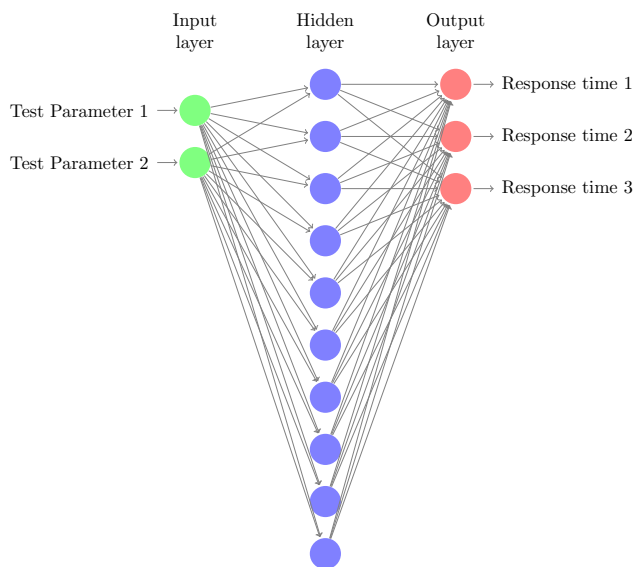

Fig. 2: Architecture of ANN with Bayesian regularised back-propagation algorithm used for creation of circuit breaker response model.

training a neural network using test input signatures and recorded main contact times. For the purpose of the presented study, the neural network architecture (shown in Fig. 2) consists of 2 neurons in the input layer, 10 neurons in the hidden layer and 3 neurons in the output layer. The selection of 10 neurons in the hidden layer came about through an iterative process of seeking the best accuracy and optimal performance. It was found that, for the presented dataset, a hidden layer with lower than 10 neurons yielded higher error, and greater than 10 neurons did not yield any improvement to the overall accuracy. The two inputs parametrise the test current signal and the three out-

put times correspond to the main contact timings of each of the three poles. The two input parameters used to characterise the input are the peak time (t_{rI}) and the peak value of the test DC current (I_p) injected into the trip coil. The contact speed timing test is repeatedly performed with variation in the recorded injected current signatures and corresponding main contact response timings (outputs). The three response times t_{rA} , t_{rB} and t_{rC} are the trip response timings for each of the three poles of the circuit breaker.

4. Results and Analysis

4.1. Experimental Results

Using the experimental configuration given in Fig. 1, 40 repetitions of the timing test are performed on the SF₆ circuit breaker. Therefore, a set of 40 × 2 input parameters and 40 × 3 output times are obtained. Figure 3 shows three examples of DC current signals injected into the trip coil during the first three timing tests. The variations in peak times and peak values of these input currents occur in practice during testing which results in variations in response times.

4.2. Training, Validation and Testing

The Bayesian Regularised Back-propagation (BRP) training algorithm was used rather than Levenberg-Marquardt Back-propagation (LMB) or Resilient Back-propagation (RB) algorithms. BRP uses adaptive weight minimisation when fitting data which is particularly useful for small noisy datasets and is often used in power applications such as load forecasting

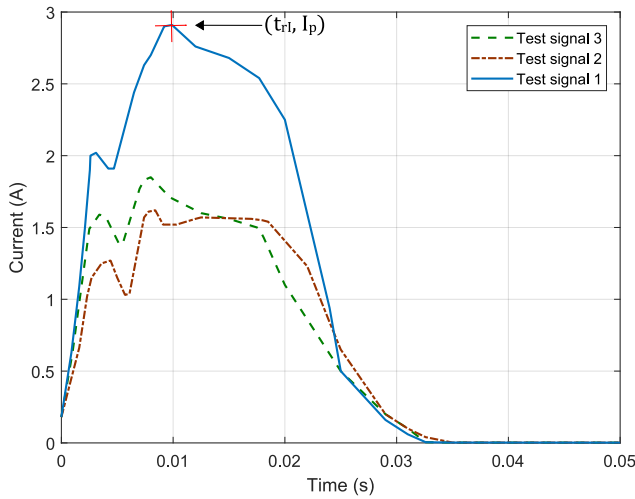

Fig. 3: Samples of DC current signals as measured during response timing tests of circuit breaker showing different peak time and peak current parameters.

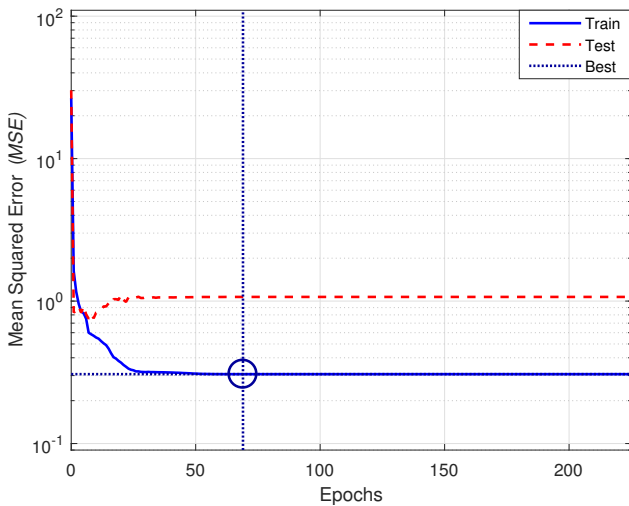

Fig. 4: Performance plot.

[14] and [15]. The 40×2 test signal parameters and 40×3 output times constituted the total dataset for the study. A total of 30 samples were used for training, 4 for validation and 6 for testing. The best training performance yielded a Mean Squared Error (*MSE*) of 0.30689 obtained at epoch 69. Figure 4 shows a graph of the *MSE* as calculated after each epoch during test and training. The distribution of the modelling error according to each instance for the testing and training processes is given in Fig. 5. The graph given in Fig. 6 shows the fitting of the data instances (training, validation and test) during the construction of the response model. A summary of the testing and validation results for the ANN-based response model is given in Tab. 1. The results for the LMB and RB algorithms are also shown for the purpose of comparison with the BRP algorithm. It should be highlighted that although the *MSE* is not as low relative to other ap-

plications, it does serve the purpose of indicating, via the experimental results, that the proposed method has the potential for assessing the condition of high voltage circuit breakers in practice.

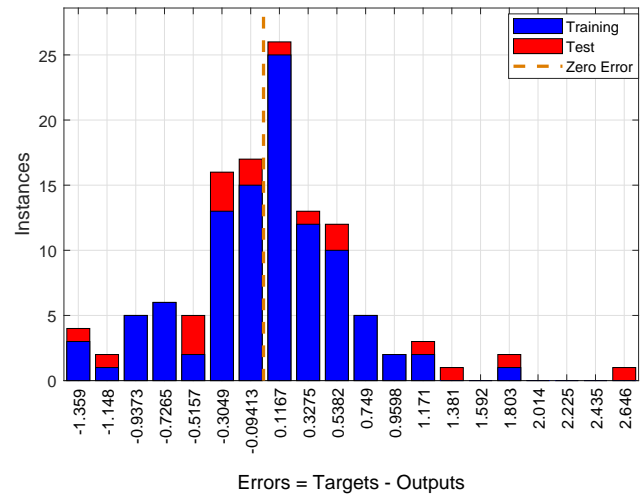

Fig. 5: Error histogram with 20 bins.

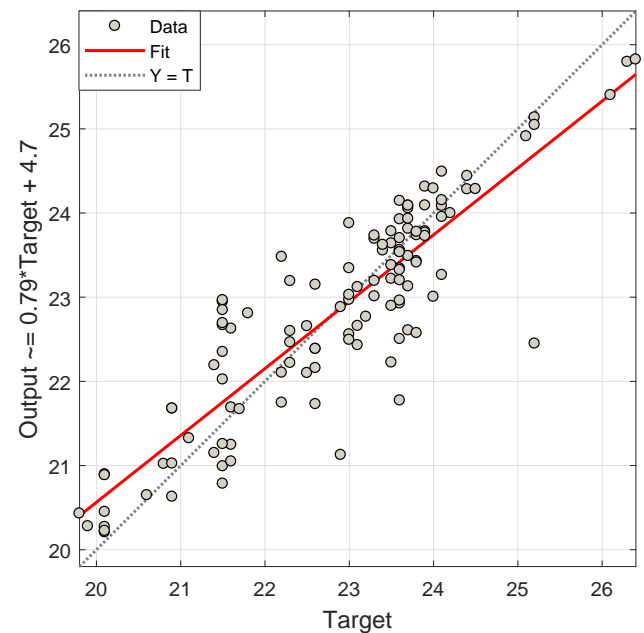

Fig. 6: Linear regression result of response times fitting with coefficient $R=0.88313$.

4.3. Discussion

An overview of the proposed response modelling methodology is given in Fig. 7(a), and the suggested condition assessment process is given in Fig. 7(b). In this study, the BRP training algorithm enabled good performance when using a total of 40 samples of input and output parameters from the circuit breaker response tests. However, depending on the test con-

Tab. 1: Summary of ANN modelling results.

Training algorithm	Process	Samples	Mean Squared Error (<i>MSE</i>)	Regression Coefficient (<i>R</i>)
BRP	Training	30	$3.06885 \cdot 10^{-1}$	$9.23055 \cdot 10^{-1}$
	Validation	4	-	-
	Testing	6	$1.06931 \cdot 10^{-1}$	$2.00826 \cdot 10^{-1}$
LMB	Training	30	$3.57976 \cdot 10^{-1}$	$9.15405 \cdot 10^{-1}$
	Validation	4	$5.44579 \cdot 10^{-1}$	$7.00173 \cdot 10^{-1}$
	Testing	6	$1.51008 \cdot 10^{-1}$	$1.99622 \cdot 10^{-1}$
RB	Training	30	$6.04194 \cdot 10^{-1}$	$7.91846 \cdot 10^{-1}$
	Validation	4	$5.19850 \cdot 10^{-1}$	$9.28050 \cdot 10^{-1}$
	Testing	6	$5.16244 \cdot 10^{-1}$	$8.73002 \cdot 10^{-1}$

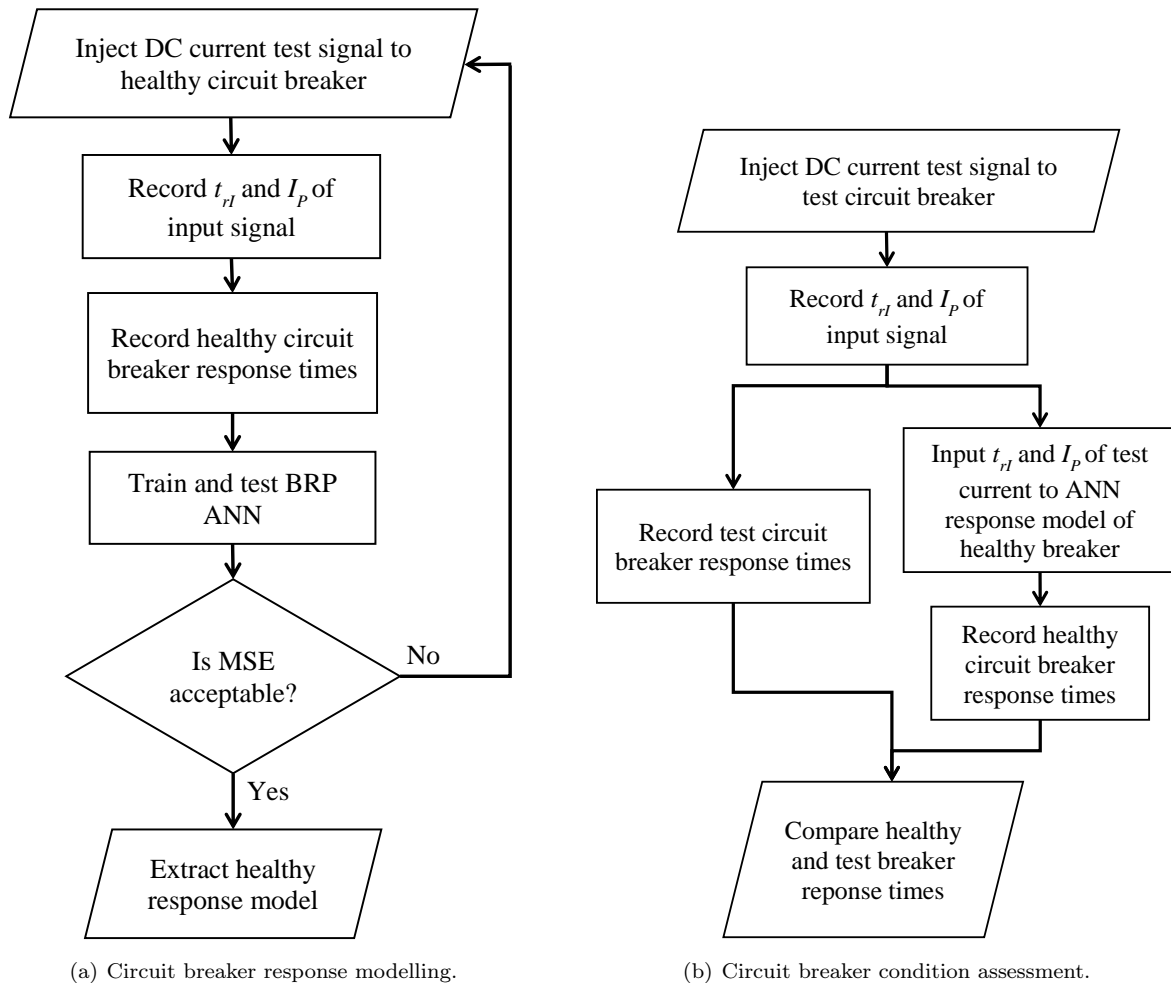

Fig. 7: Flow diagrams.

ditions, the *MSE* will differ. It is therefore recommended that the circuit breaker response test should be repeated during the response modelling process until a suitably low *MSE* is acquired. Following the creation of the response model, the healthy state of the circuit breaker can then be compared to its current state at the time during its life whether it is a part of condition-based or interval-based maintenance. The assessment of the circuit breaker’s condition is based on a comparative analysis of the response times of the response model (circuit breaker at healthy state) and

the current condition of the breaker. In this way, the response times can now be compared using a suitable technique to estimate how significant the difference, if any, of the circuit breaker’s response times, are to its healthy state’s responses. In this work, the model is obtained while the switch analyzer is picking up the performance of the breaker. In the presented experimental tests, the analyser commands the breaker to be opened in offline mode. Hence, the switching performance may be different under high voltage stress - i.e. under an in-situ test scenario. Additionally, the inter-

rupter performance may not only be affected by the amplitude of the rise time of the DC current source injected but also other characteristics arising from the electric tension. The benefit of the presented method is that response modelling can be carried out under offline or online provided that it is done consistently - i.e. if the model construction is done using offline test results then condition assessment must also be done in offline mode and vice versa.

5. Conclusion

The condition of high voltage circuit breakers is typically assessed through means of model-based methods. However, there are drawbacks to these methods such as the need for historical data. Inaccuracies thus arise from variations between operating or test conditions of the device under test and those used to build the model or as references. The presented methodology overcomes these drawbacks and enables more effective model-based condition assessment through ANN. ANN is used to construct a response model such that the circuit breaker's condition can be compared to its previous state using the same input conditions. This enables the deterioration or degradation of the circuit breaker's function to be assessed at any stage during its life.

References

- [1] BOUDREAU, J. and S. POIRIER. End-of-life assessment of electric power equipment allowing for non-constant hazard rate - Application to circuit breakers. *Electrical Power and Energy Systems*. 2014, vol. 62, iss. 1, pp. 556–561. ISSN 0142-0615. DOI: 10.1016/j.ijepes.2014.05.016.
- [2] ZHANG, Z., J. ZHANG, E. GOCKENBACK and H. BORSI. Life management of SF 6 circuit breakers based on monitoring and diagnosis. *IEEE Electrical Insulation Magazine*. 2009, vol. 25, no. 3, pp. 21–29. ISSN 0883-7554. DOI: 10.1109/MEI.2009.4976899.
- [3] ZHONG, J., W. LI, R. BILLINGTON and J. YU. Incorporating a condition monitoring based aging failure model of a circuit breaker in substation reliability assessment. *IEEE Transactions on Power Systems*. 2015, vol. 30, no. 6, pp. 3407–3415. ISSN 0885-8950. DOI: 10.1109/TPWRS.2014.2387334.
- [4] KONG, X., H. J. LIU, Y. Z. XIE, J. GUO, Q. LIU, Y. H. CHEN, S. F. WANG and X. M. SUN. High-voltage circuit-breaker insulation fault diagnosis in synthetic test based on noninvasive switching electric-field pulses measurement. *IEEE Transactions on Power Delivery*. 2016, vol. 31, no. 3, pp. 1168–1175. ISSN 0885-8977. DOI: 10.1109/TPWRD.2015.2430523.
- [5] ZHANG, X. and E. GOCKENBACK. Age-dependent maintenance strategies of medium-voltage circuit-breakers and transformers. *Electric Power Systems Research*. 2011, vol. 81, no. 8, pp. 1709–1714. ISSN 0378-7796. DOI: 10.1016/j.epsr.2011.03.018.
- [6] JANSSEN, A., D. MAKEREINIS and C. SOLVER. International surveys on circuit-breaker reliability data for substation and system studies. *IEEE Transactions on Power Delivery*. 2014, vol. 29, no. 2, pp. 808–814. ISSN 0885-8977. DOI: 10.1109/TPWRD.2013.2274750.
- [7] BALZER, G., D. DRESCHER, F. HEIL, P. KIRCHESCH, R. MEISTER and C. NEUMANN. Evaluation of failure data of HV circuit-breakers for condition based maintenance. In: *CIGRE* [online]. Paris: CIGRE, 2004. Available at: <http://www.transform.ru/articles/pdf/SIGRE/a3-305.pdf>.
- [8] RUSEK, B., G. BALZER, M. HOLSTEIN and M. CLAESSENS. Timings of high voltage circuit-breaker. *Electric Power Systems Research*. 2008, vol. 78, no. 12, pp. 2011–2016. ISSN 0378-7796. DOI: 10.1016/j.epsr.2008.06.012.
- [9] CHENG, T., W. GAO, W. LIU and R. LI. Evaluation method of contact erosion for high voltage SF6 circuit breakers using dynamic contact resistance measurement. *Electric Power Systems Research*. 2018, vol. 163, iss. 1, pp. 725–732. ISSN 0378-7796. DOI: 10.1016/j.epsr.2017.08.030.
- [10] PEESAPATI, R., V. K. YADAV and N. KUMAR. Assessment of temporary overvoltages during network lines re-energization. *Advances in Electrical and Electronic Engineering*. 2016, vol. 14, iss. 3, pp. 227–235. ISSN 1804-3119. DOI: 10.15598/aeec.v14i3.1775.
- [11] BENHAMIDA, F. and R. BELHACHEM. Dynamic constrained economic/emission dispatch scheduling using neural network. *Advances in Electrical and Electronic Engineering*. 2013, vol. 11, iss. 1, pp. 1–9. ISSN 1804-3119. DOI: 10.15598/aeec.v11i1.745.
- [12] ZALIS, K. Solving of some Problems with On-Line Mode Measurement of Partial Discharges.

Advances in Electrical and Electronic Engineering. 2011, vol. 3, iss. 2, pp. 115–118. ISSN 1804-3119.

- [13] NATTI, S. and M. KEZUNOVIC. Assessing circuit breaker performance using condition-based data and Bayesian approach. *Electric Power Systems Research*. 2011, vol. 81, no. 9, pp. 1796–1804. ISSN 0378-7796. DOI: 10.1016/j.epsr.2011.04.010.
- [14] KHWAJA, A. S., X. ZHANG, A. ANPALAGAN and B. VENKATESH. Boosted neural networks for improved short-term electric load forecasting. *Electric Power Systems Research*. 2017, vol. 143, iss. 1, pp. 431–437. ISSN 0378-7796. DOI: 10.1016/j.epsr.2016.10.067.
- [15] SAINI, L. M. Peak load forecasting using Bayesian regularization, Resilient and adaptive backpropagation learning based artificial neural networks. *Electric Power Systems Research*. 2008, vol. 78, no. 7, pp. 1302–1310. ISSN 0378-7796. DOI: 10.1016/j.epsr.2007.11.003.

About Authors

Wesley DOORSAMY received the B.Sc, M.Sc. and Ph.D. Degrees in Electrical Engineering from the University of the Witwatersrand in Johannesburg, South Africa in 2008, 2013 and 2015, respectively. He is currently a senior lecturer at the University of Johannesburg and is an active member of both the Institute of Electrical and Electronics Engineers (IEEE) and South African Institute of Electrical Engineers. His research interests are in the area of intelligence in power engineering applications.

Pitshou BOKORO received M.Phil. and Ph.D. Degrees in Electrical Engineering from the University of Johannesburg, in 2011, and University of the Witwatersrand, in 2016, respectively. He is a senior lecturer at the University of Johannesburg and a member of both the Institute of Electrical and Electronics Engineers (IEEE) and South African Institute of Electrical Engineers. He works in the area of Power Systems and Surge Protection.