



Citation for published version:

Burke, RD, Lewis, AJ, Akehurst, S, Brace, CJ, Pegg, I & Stark, R 2012, 'Systems optimisation of an active thermal management system during engine warm-up', Proceedings of the Institution of Mechanical Engineers, Part D: Journal of Automobile Engineering, vol. 226, no. 10, pp. 1365-1379.
<https://doi.org/10.1177/0954407012441883>

DOI:

[10.1177/0954407012441883](https://doi.org/10.1177/0954407012441883)

Publication date:

2012

Document Version

Peer reviewed version

[Link to publication](#)

University of Bath

General rights

Copyright and moral rights for the publications made accessible in the public portal are retained by the authors and/or other copyright owners and it is a condition of accessing publications that users recognise and abide by the legal requirements associated with these rights.

Take down policy

If you believe that this document breaches copyright please contact us providing details, and we will remove access to the work immediately and investigate your claim.

Systems Optimisation of an Active Thermal Management System during Engine Warm-up

RD Burke, AJ Lewis, S Akehurst, CJ Brace, I Pegg and R Stark

ABSTRACT

Active thermal management systems offer a potential for small improvements in fuel consumption that will contribute to upcoming legislation on CO₂ emissions. These systems offer new degrees of freedom for engine calibration, however their full potential will only be exploited if a systems approach to their calibration is adopted, in conjunction with other engine controls.

In this work, a DoE approach is extended to allow its application to transient drive cycles performed on a dynamic test stand. Experimental precision is of crucial importance in this technique since even small errors would obscure the effects of interest. The dynamic behaviour of the engine was represented mathematically in a manner that enabled conventional steady state modelling approaches to be employed in order to predict the thermal state of critical parts of the engine as a function of actuator settings. A 17 point test matrix was undertaken and subsequent modelling and

optimisation procedures indicated a potential 2-3% fuel consumption benefits under iso- NO_x conditions.

Reductions in thermal inertia appeared the most effective approach for reducing engine warm-up time which translated approximately to a 1.3% reduction in fuel consumption per kilogram of coolant. A novel oil cooled EGR system showed significant benefits in EGR gas cooling, reducing inlet gas temperatures by 5°C and subsequently NO_x emissions by 6%, in addition to increasing the warm up rate of the oil. This suggested that optimising the thermal management system for EGR gas cooling can offer significant improvements.

For the first time this paper presents a technique that allows simple predictive models of the thermal state of the engine to be integrated into the calibration process in order to deliver optimum benefit. In particular, it is shown how the effect of the thermal management system on NO_x can be traded off, by advancing injection timing, to give significant improvements in fuel consumption.

Key Words: Thermal management; Engine calibration; Design of Experiments; warm-up; fuel consumption; optimisation;

1 Introduction

The ever increasing environmental, economic and legislative drivers [1-3] for improved fuel economy are pushing manufacturers to investigate all sub-systems for even the relatively small benefits. Whilst individually the impact of these improvements may be small, together they can result in a large difference. These benefits may be applied in the relatively short term future but will provide essential benefits as most manufacturers predict continued use of the internal combustion engine for the foreseeable future [4]. Because of their relatively low impact on costs, these systems represent a pragmatic approach to improved fuel economy and are more likely to be adopted in production.

The engine thermal management system (TMS), or cooling system is such a system that has received little attention over the past 20 years and the conventional layout is a simple and cost effective design. Passive control of engine temperature is typically achieved through a wax element thermostat that targets a constant coolant temperature. Although the system is reliable, there are significant variations in metal temperature over the speed-load operating range of the engine. These systems are designed to operate under worst case conditions such as an uphill trailer tow where the engine load is high giving high temperatures, but the engine and vehicle speeds are low meaning coolant flow and air flow over the radiator are also low [5]. However, at more common operating conditions the system is oversized and energy can be wasted in addition to

over-cooling the engine and causing higher frictional losses. Proposed improvements to this system have focused on reducing the power consumption of the coolant pump and optimising the thermal state of the engine at all operating points [6].

Active systems tend to replace the mechanical pump and thermostat with flow control valves and an electric pump. Some active systems are only beneficial under fully warm conditions and do not offer any benefits during warm-up because they do not change the available energy per unit thermal mass [7-9]. To achieve benefits during warm-up either reduced inertia or heat addition must occur [6]. Careful placing of coolant control valves can improve engine behaviour during warm-up by isolating parts of the circuit and effectively reducing thermal inertia during warm-up.[10] Recent production engines on higher-end applications have employed these systems in the form of switchable coolant pumps [11], or through the active control of coolant flows [12].

The active systems allow the control of heat flows to the different fluids with some examples encouraging heat flow to engine oil to try to reduce frictional losses due to oil viscometrics. Andrews et al. [13] used an exhaust to oil heat exchanger during warm up to improve oil warm-up and achieve better fuel consumption. Simulations by Kunze *et al.* [14] showed that a 2MJ heat addition to engine oil should provide 1.5% reduction in FC through reduced frictional losses. In addition, changes to the engine thermal state

during warm-up will affect combustion temperatures with a knock on effect on emissions. If warm-up occurs faster, carbon monoxide (CO) and unburned hydrocarbons (HC) will be expected to reduce whilst oxides of nitrogen (NO_x) emissions should increase. Changing the warm-up rate also interacts with the engine strategy as engine temperature is a key input to the control of many systems including injection timing (SOI), multi-injection strategies and exhaust gas recirculation (EGR) rates. These interactions have been seen to compromise overall fuel consumption benefits from improved thermal management systems and some aspects of the strategy should be included in the active TMS calibration [10, 15].

The aim of this work is to establish an optimised calibration for the use of an active thermal management system that introduces a number of degrees of freedom to the engine. Based on scoping exercises, injection timing should also be included in the calibration routine [10].

2 Methodology

2.1 *Concept active TMS*

A prototype active TMS was designed based on the requirements for improved warm-up. A scoping exercise was previously conducted on the system to understand the basic behaviour [10]. In this current work the cooling system hardware was installed on a

second engine equipped with significantly more instrumentation. A rigorous design of experiments approach was adopted to capture a detailed understanding of the system and apply optimisation techniques.

The modified coolant and oil hydraulic circuits are shown in figures 1 and 2 respectively. As this study was focused on engine warm-up, the heater matrix that would supply cabin heating was removed. The conventional wax element thermostat was replaced by a pressure regulated thermostat (PRT). This component is also a wax element device, but is sensitive to both top-hose and bottom-hose coolant temperatures meaning it can react to cooling potential over the radiator [8]. The active thermal management system included:

- (a) Engine-out coolant throttle
- (b) EGR coolant loop throttle
- (c) Oil cooler coolant flow control valve
- (d) Dual EGR system

The coolant throttle located at engine outlet aims to isolate the front end coolant loop during warm-up. The scoping work on this system showed that when this valve was open, coolant was allowed to flow through the degas bottle. If this throttle was closed during warm-up there would still be a small coolant flow round the main loop, but not

through the degas bottle. Effectively, this volume of coolant did not participate in engine warm-up. Thermostat opening was also delayed thus suppressing some radiator losses [10].

The other three active devices were intended to be used to direct heat flow between coolant and oil:

- EGR gas heat could be flowed to either fluid by switching the EGR cooler. The oil EGR loop was built using an identical heat exchanger and valve assembly, setup in parallel to the coolant cooled leg. In both cases EGR valve cooling was provided from the coolant.
- Heat transfer between coolant and oil was controlled by the 4 way valve.
- The second coolant throttle in the second leg could control coolant flow in the oil cooler and coolant EGR cooler, but also impacted on flow in the block. In the oil circuit an adaptor plate was required to provide outlet and inlet ports for flow to and from the second EGR cooler.

The control of the thermal management system was achieved through a prototype strategy within the engine control unit (ECU) using Ati Vision calibration tool and the “*no hooks*” functionality. Both coolant throttles were controlled open loop with the set-point dependent on engine speed, fuelling and measured cylinder head temperature. The

set-point control was map based as shown in figure 3 for the engine-out throttle. Considerable effort was made for the engine-out throttle to achieve fastest warm-up, but also a constant cylinder head temperature of about 105°C during fully-warm operation. The second coolant throttle and the 4-way valve set-points were maintained constant throughout engine operation.

Although the 2 EGR coolers were physically installed in parallel, the control algorithm was designed such that only one would operate at any given time. This was achieved by maintaining one gas side EGR valve closed whilst the other was controlled by the production ECU algorithm. In all cases, oil and coolant would flow through their respective EGR cooler, regardless of flow on the gas side.

Injection timing was varied by applying an offset to the production calibration. This was used in the previous publication on this system [10] and the appropriate excitation range was to advance 1-3°CA.

2.2 *Dynamic optimisation over NEDC*

It was desirable to optimise the system for lowest fuel consumption during warm-up and the new European drive cycle (NEDC) was used as a reference test. The first urban phase is low power giving quite long warm-up times but is typical of commuter traffic where the engine often operates from cold start. A design of experiments (DoE) based

optimisation process was used to calibrate the five input variables to minimise fuel consumption whilst maintaining emissions performance.

Experimental design techniques allowed the number of tests required to capture the system behaviour to be kept to a minimum. Each experiment of the test plan consisted of a full cold start NEDC with different calibration settings for the five inputs for each test. In this way an experimental design approach more commonly applied to steady state test points was applied to a dynamic test cycle, with the experimental factors applied throughout each cycle to allow the effect on both final results and dynamic behaviour to be studied. It was important to keep the number of tests to a minimum because although the NEDC duration is only about 40 minutes (20minutes drive cycle + preparation time), the temperature soak times between experimental runs is long. A well-controlled forced cooling procedure allowed two tests to be performed per day whilst maintaining good repeatability; however the 17 point test programme was completed in a 4 week period when considering repeat points and inevitable experimental difficulties. The test plan was a D-optimal design and the 17 experiments are listed in table 1. The EGR cooler type and oil cooler bypass valve (variables 3 and 4 in table 1) had two distinct settings, however continuous control of the other variables was possible. For the coolant throttles (variables 1 and 2), a mid-point was used to

assess any curvature in the response (DoE Number 17). In each case the calibration was maintained for the whole duration of the NEDC.

#	1	2	3	4	5
DoE Number	Engine coolant throttle	out EGR Coolant flow	Oil Cooler HE Bypass	EGR valve	SOI advance (o)
1	Mapped	Low	Bypass	Oil	0
2	Open	Low	Bypass	Oil	1.5
3	Mapped	Low	Bypass	Coolant	0
4	Open	Low	Bypass	Coolant	3
5	Open	Low	On	Oil	0
6	Open	High	Bypass	Oil	1.5
7	Mapped	High	Bypass	Coolant	1.5
8	Open	High	On	Coolant	0
9	Open	Low	Bypass	Coolant	1.5
10	Mapped	Low	On	Coolant	1.5
11	Mapped	High	Bypass	Oil	3
12	Mapped	Low	On	Oil	3
13	Mapped	High	On	Oil	1.5
14	Open	High	Bypass	Oil	0
15	Open	High	On	Coolant	3
16	Mapped	High	Bypass	Coolant	0
17	Mapped*	Mid	On	Coolant	0

* Test 17 used the same mapped setting, but a lower threshold was introduced, effectively maintaining a minimum throttle opening and minimum coolant flow. This produced a result with a mid-flow setting throughout the test.

Table 1: Experimental design test points for assessing active thermal management system

Because of the small number of tests relative to the number of inputs, it was expected to be difficult to extract meaningful conclusions from the raw data and response models were required to analyse and understand the system behaviour. Simple polynomial

modelling was used in this study and all modelling work was carried out in the Mathworks Matlab Model Based Calibration (MBC) toolbox. The modelling structure is shown in figure 4 and in each case were calculated using multi-linear regression. In each case an initial model was built using all 1st and 2nd order terms linear and two way interactions as appropriate from the experimental design; this was subsequently reduced using stepwise parameter selection to yield models with a small number of parameters and acceptably high level of fit (R^2) and predictive capability (PRESS analysis).

To apply this structure to the dynamic events, suitable measures needed to be chosen that capture the dynamic behaviour over the drive cycle, but that were also useable within the polynomial modelling approach. A "single value per test" was established for each measurement based on a mean or change over the dynamic event. For each input and output measurement type this quantification method is listed in table 2. For the injection timing, the average timing expressed in °BTDC of the main injection was used rather than the offset defined in table 1 as this has the advantage of including any effects of warm-up rate on the ECU strategy. Engine temperature has a strong influence on injection timing and changes in warm-up rate over different NEDC tests will affect the injection timing behaviour test-to test.

INPUTS	
Metric	Quantification
Main loop coolant flow	Number of kg of flow over phase
Oil Cooler	Qualitative measure: On or Off
EGR loop coolant flow	Number of kg of flow over phase
EGR cooler type	Qualitative measure: Coolant or Oil
Mean injection timing	Average main injection timing over test phase
OUTPUTS	
Metric	Quantification
Oil/coolant/metal temperatures	Temperature rise (phase 1) or Average temperature (phase 2)
Heat Flux	Total energy loss over test phase
Convective heat transfer coefficients	Average over test phase
Emissions/FC	Mass used/produced

Table 2: Variable quantification for modelling

With the polynomial models capturing the various dynamic behaviour of the system, model based optimisation was carried out for fuel consumption (FC) and NO_x emissions. The aim of this optimisation was to minimise FC whilst maintaining NO_x emissions at the baseline engine level. All optimisation was performed in the Mathworks Matlab Calibration Generator (CAGE) software. The NEDC is often split into two phases representing the 4 repeat urban cycles and the extra urban cycle. This split is convenient as phase 1 approximately represents the coolant warm-up phase. It was decided to calculate separate optimisation calibrations targeted at each phase.

The calibration process was concluded by validating the optimised calibrations experimentally on the engine. In this case a number of repeat experiments were conducted to establish good confidence in the measured results.

It should be noted that the inclusion of instrumentation in the coolant circuit to measure coolant flow rates caused an increase in coolant volume compared to the production engine of about 2L. However, the active cooling hardware had very little effect on total volume. Conversely, in the oil circuit the Dual EGR system increased total oil volume by around 0.6L. This was unavoidable due to the prototype nature of the installation. It was estimated that the increase in oil volume could be avoided in an optimised production configuration. Therefore the performance of the optimised system should be compared against the performance of the system with the active thermal management system installed, but not used.

3 Experimental facilities

3.1 *Instrumented engine*

The engine used in this study was a 4 cylinder, 2.4L turbocharger, common rail injection Diesel engine in use in a small commercial vehicle and meeting EURO IV emissions specification. The engine was well run in and care was taken to ensure appropriate oil ageing for all experiments. Because the anticipated changes in engine behaviour are small, extensive instrumentation was installed on the engine to capture the engine thermal state, friction and energy transfers. Over 100 thermocouples were installed to measure metal and fluid temperatures both within the engine structure and around the internal and external circuits. A number of these thermocouples were

arranged in arrays of three to create multipoint sensors, allowing thermal gradients to be measured and local heat flux to be calculated [16]. These multipoint sensors were installed at different locations around the cylinder bores. For each multipoint in the vicinity of the coolant jacket, a local coolant thermocouple was fitted to measure coolant temperature thus allowing convective heat transfer to be estimated. The inter bore regions of the engine block had Siamese regions near top dead centre (TDC) and in the lower part of the bore, but cross-flow coolant passages for the majority of the stroke. The layout of these sensors and their locations in the cylinder block are detailed in figures 5 and 6 respectively. Clearly these sensors offer no insight into heat flows down the bore which could be quite substantial during warm-up, however they will allow the relative change to be quantified in response to changes in the thermal management system.

Other thermocouples were installed in the bearing caps to measure metal and oil film temperatures. The remainder were installed to measure fluid temperatures at key locations in the coolant and oil circuits.

Accurate and repeatable dynamic measurements of fuel consumption and exhaust emissions were required. Correction factors were used to improve the accuracy of fuel consumption measurements, notably as a result of thermal expansion of the fuel over

thermal transients [17]. Exhaust emissions were measured pre- and post- catalyst using Horiba MEXA 7000 emissions analysers and careful time alignment of these measurements during dynamic experimentation was required such that measurements of air flow and emissions concentrations were in phase [18]. Fuel consumption was measured directly from a CP FMS1000 gravimetric fuel beaker, deduced from carbon balance of the pre-catalyst exhaust emissions and estimated from the fuelling demand recorded from the ECU.

3.2 *Dynamic experimental facility*

The engine was installed on a transient dynamometer and controlled by a CP engineering host system. Access to the ECU calibration was achieved using an ATi Vision system, connected to the host system via ASAP3 link. The NEDC duty cycle was controlled directly by the host system through a transient schedule of engine speed and torque. Engine speed was controlled by the dynamometer while engine torque was controlled using a PID controller acting electronically on the engine accelerator pedal position. The NEDC duty cycle for the engine used in this study is shown in figure 7.

Following each test a rigorous checking procedure was performed to identify and correct any issues arising with either engine or sensor behaviour. It is important that this is conducted as repeating large numbers of experiments is difficult without excessively increasing the overall experimental effort.

Two tests were run each day with the first following an overnight soak in the temperature controlled environment and the second following a forced cool down procedure. The cool down procedure had been previously validated and shown no statistical differences compared to the overnight soak [19]. In all cases the start temperatures throughout the engine were checked before each experiment.

4 Results

4.1 Modelling results

The following sections detail the overall findings from each of the response models calculated for different measurements of temperature, fuel consumption and emissions.

Thermal results

Engine oil temperatures responded to three of the control parameters and local measurements showed this behaviour was consistent throughout the internal oil circuit:

- During warm-up, engine out coolant throttling increased oil temperatures by about 6°C compared to the non-throttled case at the end of phase 1 of the NEDC.
- The control of heat flow in the oil cooler and dual EGR system allowed oil temperatures to be increased further during warm-up: By allowing coolant flow through the oil cooler or by using oil cooled EGR individually, each also provided approximately 6°C hotter oil at the end of phase 1. If both were used

together, the total increase was only about 7°C showing a limitation in maximum oil warm-up (see figure 8).

Coolant temperatures around the circuit could be related to the temperature at two distinct points:

- the temperature at engine inlet;
- the temperature at engine outlet.

The effect of engine-out coolant throttling was to isolate a significant part of the front end circuit during warm-up by stopping flow through the degas bottle and reducing thermostat leakage such that no flow of warm coolant was measured at the top hose (radiator inlet). The resulting lower overall thermal inertia and reduced flow rates significantly increased the temperature at engine outlet. In theory, the coolant temperature at engine inlet would also be expected to warm-up faster, however as shown in figure 9 this was not the case and the coolant inlet temperature was in fact lower. Analysis of coolant temperatures around the circuit show this is a result of the colder coolant in the degas leg of the circuit.

The control of heat flow between engine fluids in the oil cooler and dual EGR system had the opposite effect on coolant compared to that on oil. This is not surprising and

bypassing coolant flow from the oil cooler and using coolant cooled EGR resulted in higher coolant temperature at the end of phase 1.

The changes in coolant temperature and flow have somewhat complex impact on heat transfer within the engine block. On the one hand, the reduced coolant flow had a negative effect on convective heat transfer because of reduced flow velocities. On the other hand, the lower coolant temperatures at engine inlet provide a larger thermal gradient between the combustion gas and the bulk fluid which resulted in more thermal potential to drive heat flow. Both these effects are clearly shown in figure 10 which illustrates the heat transfer environment half way down the bore. The heat loss from the cylinders is therefore the result of reduced convective heat transfer but increased thermal gradient, with the larger thermal gradient having the dominant effect.

Both the coolant and oil circuits provide cooling for the engine components. Consequently, the metal temperatures are strongly linked to one of these two fluids:

- Metal temperatures in the cylinder head correlated well with coolant temperatures
- Metal temperatures in the main bearing caps correlated well with oil temperatures

- Temperatures in the upper part of the cylinder liner correlated with engine-out coolant temperatures which was interesting because their proximity to the coolant inlet would suggest they be closely linked to that temperature.
- Temperatures in the lower part of the liner, notably below the coolant jacket, presented only very weak correlations with coolant temperature. This is explained by the influence from both coolant and lubricating fluids which each contribute to cooling in this area.

Emissions/FC results

Similar response models were calculated for fuel consumption and emissions to understand the effects of the active thermal management system on these key outputs for homologation testing.

Response models were fitted for each of the three measurements of fuel consumption available at the facility (gravimetric fuel balance, carbon balance of feed-gas emissions and ECU demand). There were some small variations between these models with respect to some interactions terms, however over phase 1 they were in agreement over the following two points:

- Injection timing dominated the response (5.5% or 20g reduction in fuel consumption for 3deg advance)

- Engine out coolant throttle produced a significant reduction in FC (2.3% or 6g reduction)
- Small benefit from oil-cooled EGR

Similarly over phase 2 the models agreed on the following points:

- 3°CA angle advanced SOI reduced FC 2.3%
- Using oil cooled EGR reduced FC by 0.5%

It was surprising that over phase 1 neither oil-cooled nor the oil cooler resulted in significant benefits in fuel consumption. Previous experiments by the authors and from the literature have shown benefits from oil cooler use during warm-up and this was expected. In this work it is thought that these effects are small compared to the other significant control variables and therefore are difficult to record from the 17 point DoE test plan. Further investigation is required isolating the EGR and oil cooler from injection timing and engine out coolant throttle.

As with FC, over phase 1 NO_x emissions were dominated by injection timing with a 3°CA advance causing a 30% increase. Using the oil-cooled EGR in place of the coolant-cooled system reduced NO_x emissions by 6%. Over phase 2 the effect of a SOI was reduced to an 8% increase in NO_x while the oil cooled EGR cooler offered 5%

reduction. The effect of the EGR cooler was influenced somewhat by the oil cooler setting with a lower benefit in NO_x from the oil cooled EGR when the oil cooler was in use (see figure 11).

The impact of the EGR cooler type is best understood by plotting the gas temperatures from each calibration as shown in figure 12. This showed oil-cooled EGR is more effective than coolant-cooled with gas temperature up to 25°C lower. As identical heat exchangers were used, this result is explained either by improved heat transfer or by the fact that oil temperature is lower than coolant temperature during warm-up. It was also noted that the gas path was longer by 160mm (20%) for the oil-cooled EGR. When used during warm-up, the oil cooler improves oil warm-up but if oil EGR is used as well, then this will impact on the gas cooling capacity: this explains the detrimental effect on NO_x from the oil cooler shown in figure 11.

Response models were also calculated for CO emissions. Over phase 1 engine out coolant throttling reduced CO emissions by 5% but using oil cooled EGR increased emissions 11%. Effectively this is the opposite effect to that of NO_x emissions and is explained by the impact of engine and intake gas temperatures on combustion temperatures.

4.2 Optimisation

The response models for FC and NO_x were used for the optimisation process which was aimed at minimising FC whilst maintaining iso-NO_x levels wherever possible. Although typical calibration tasks are much more complex and include all other emissions, smoke, cabin heating and drivability issues, this exercise represents the typical trade-off for calibration engineers and is a good illustration of the method presented in this work. The results from the optimisation and the predicted fuel consumption benefit for phases 1 and 2 are summarised in table 3.

Variable	ECE15 - Phase 1	EUDC - Phase 2
Engine-out throttle	Mapped	Mapped
EGR loop coolant throttle	Min flow	Min flow
EGR cooler type	Oil-cooled	Oil-cooled
Oil cooler	On	Bypass
SOI	Advance 1.2°	Advance 1.5°
Anticipated FC benefit at iso-NO _x	12g (-3.2%)	10g (-2%)

Table 3: Optimised calibrations for controlled thermal management system and expected benefits from response model

Before validation experiments are presented it is worth discussing the calibration of the control variables in light of the modelling work. Most calibration tasks would not have the benefit of the extensive instrumentation and this can be used to understand some of the variable settings. As previously discussed, phase 1 represents the warm-up phase and the optimised setup relies on targeting fast warm-up and focusing heat flow to the

engine oil. During phase 2, the changes in oil viscosity with temperature changes become much smaller due to the asymptotic relationship with temperature. Also, phase 2 is the main contributor to NO_x emissions because the engine is both hotter and operating under higher loads. The combination of these factors means that the effect of improved charge air cooling by the oil EGR system is much more significant than benefits in fuel consumption from hotter oil. Consequently, the optimised setup aims to keep EGR gas temperatures to a minimum.

Considering first the setup for phase 1:

- Mapped engine-out flow and minimum EGR loop flow aim to maximise engine warm-up rate;
- The use of oil cooler and oil-cooled EGR aim to maximise oil warm-up rate;
- Advanced SOI counteracts the ECU tendency to retard fuel injection with faster warm-up rates, which are normally in place for NO_x emissions control.

For phase 2,

- The mapped engine-out coolant throttle aims to raise the target coolant temperature at part load.
- The combination of oil-cooled EGR and bypassed oil cooler aims to provide maximum EGR gas cooling. As oil temperatures remain lower than coolant

temperatures during the majority of phase 2, bypassing the oil cooler keeps the oil temperature lower.

- Advanced SOI aims to trade-off the benefits in NO_x from improved EGR gas cooling to yield benefits in fuel consumption.

Although two separate optimised setups have been proposed aiming for minimum fuel consumption at iso-NO_x for each of the two drive cycle phases, clearly a combined optimum setup would also be desirable. This could be achieved by switching between the two optimised calibrations as the drive cycle moves from phase 1 to phase 2, however it is unlikely the benefits will be additive due to differences in thermal state at the end of phase 1 following each of the calibrations.

4.3 Validation

The optimised calibrations were subsequently tested on the engine to validate the model predictions. A series of five repeat tests were conducted in each of the calibrations and at a reference condition, referred to as *baseline*. As the difference in calibrations was purely software based, the experiments were randomised to remove bias due to time related disturbances. The coolant and oil temperature evolutions over the NEDC are plotted in figure 13 and clearly show the faster warm-up rate for the optimised calibrations. Coolant temperature is slightly higher for the phase 2 calibration because

the oil cooler is bypassed, however there does not appear to be a significant difference on oil temperature mainly because both optimised calibrations use oil cooled EGR.

Figure 14 compares phase 1 FC and NO_x predictions to measured results from the validation testing. The error bars for the model prediction are based on the fit error from the regression calculations. The error bars on the validation testing represent 95% confidence intervals for those tests.

The fuel consumption results agree well, however there was less agreement between the raw measured NO_x results and the model prediction. An offset of about 0.15g (10%) was observed between the model predictions and the measured results. Despite this offset, the relative difference in NO_x between the baseline and optimised calibrations was similar for both the model prediction and measured results. It should be noted at this stage that the model training data and the validation data were recorded with an interval of around 6 months due to other testing constraints. As a result, the training data was recorded during winter and the validation during summer. The experiments were conducted in a controlled temperature environment; however there was no control over ambient humidity. Analysis of the ambient conditions showed a large difference in ambient humidity levels between the two testing campaigns which correlated with the changes in measured NO_x levels. The effects of humidity on NO_x emissions formation

are well known and a standard correction factor has been established to account for these changes. Although this correction factor has been applied in the results presented in this paper, it did not appear sufficiently aggressive in light of the correlation between NO_x results and ambient humidity. An empirically derived correction factor was established based on repeat tests performed throughout the year at different humidity levels and these results are plotted as *dotted box plots* in figure 14 (b). The results using this correction factor are shown in conjunction with the results from the standard correction procedure as guidance, and the details of the empirical correction factor will be the subject of a future publication. The corrected results present excellent agreement with the model predictions.

Figure 15 shows the same results for the system optimised for phase 2 of the drive cycle. Similar analysis applies to these results as for phase 1 and again excellent agreement between the model prediction and measured validation results was shown when considering the spread of data. The results for phase 2 are not as good as phase 1, and this is thought to be a result of the lower control over phase 2 start conditions (because they are subject to variations during phase 1) and the relative importance of NO_x emissions produced during the latter stages of the drive cycle.

Tables 4 and 5 summarise other measurements showing good agreement between the model predictions and validation results; these are shown for phase 1 and 2 respectively. Various temperature rises (phase 1) and mean temperatures (phase 2) are reported at key locations in the engine along with fuel consumption and NO_x emissions for completeness.

	Variable	Baseline		Optimised phase 1	
		Predicted	Measured	Predicted	Measured
Temperature rise (°C)	ECU	53	55	59	61
	Oil Main Gallery	49	52	53	55
	Crank cap oil film	49	51	53	54
	Liner Mid stroke	55	57	59	61
FC/ Emissions (g)	Carbon Balance	371	373	366	363
	Gravimetric	372	372	360	361
	NO _x	1.37	1.22 (1.37)	1.36	1.19 (1.33)

Table 4: Comparison of predicted and actual behaviour for phase 1 for selected temperature rises, fuel consumption and NO_x emissions (NO_x results obtained using empirical correction factor are in brackets)

	Variable	Baseline		Optimised phase 2	
		Predicted	Measured	Predicted	Measured
Mean Temperature (°C)	ECU	92	93	103	103
	Oil Main Gallery	85	87	91	94
	Crank cap oil film	90	92	95	98
	Liner Mid stroke	93	94	99	101
FC/ Emissions (g)	Carbon Balance	506	517	496	504
	Gravimetric	504	505	494	493
	NO _x	4.18	3.48 (3.92)	4.3	3.92 (4.49)

Table 5: Comparison of predicted and actual behaviour for phase 2 for selected temperature rises, fuel consumption and NO_x emissions (NO_x results obtained using empirical correction factor are in brackets)

5 Discussion

5.1 DoE approach

The approach of combining DoE with the transient NEDC test points performed well and gave consistent results. The DoE approach is more commonly used to run a series of steady state operating points and the performance of this method is related to accuracy and repeatability of running those steady operating points. For the approach in this work, it is of key importance that the 20 minute dynamic schedule be accurate and repeatable for all DoE test points. This is even more challenging because of the small differences in engine behaviour that were achieved through changes to the thermal management system.

It was unfortunate that the variations in injection timing have dominated a number of response variables and shows that the test plan was ill-conditioned. This is a little surprising as the excitations levels were chosen based on results from scoping experiments using the same thermal management system.

Agreement between the model predictions and validation testing results shows good control of the calibration procedure. FC and NO_x emissions have complex measurement

systems and many possible error sources, however these have been successfully managed which has resulted in additional confidence in the optimised calibrations.

5.2 Active thermal management system behaviour

The main fuel consumption benefit during engine warm-up was a result of reduced thermal inertia. This was achieved by isolating the engine degas bottle and radiator from the system as a result of engine-out coolant throttling. Temperature measurements showed that this improved warm-up rate throughout the engine and the benefits were seen both in the engine structure and lubricating fluid. Based on the modelling result, the reduction in fuel consumption is around 6g (2%), while the mass of coolant isolated from the system was approximately 1.5kg. It could therefore be estimated that reductions in thermal inertia equate approximately to 4g/kg coolant fuel saving (1.3%/kg).

The dual EGR and oil cooler allowed control of heat flows to coolant and oil. In varying the control of these devices, a trade-off between heating the *coolant and upper engine* or *the oil and lower engine* appeared. This is illustrated in figure 16: the coolant temperature rise over phase 1 is plotted against the oil temperature rise for a number of different simulated calibrations.

- Enabling the oil cooler during warm-up gives a larger oil temperature rise but is detrimental to coolant warm-up

- Switching from coolant cooled to oil cooled EGR improves oil warm-up, again to the detriment of coolant warm-up.
- As discussed in the previous paragraph, throttling engine-out coolant flow improves both coolant and oil warm-up.

With the engine coolant throttle closed, changes to the oil cooler and EGR cooler control create a Pareto front in terms of engine warm-up.

It was interesting to note the effectiveness of oil-cooled EGR compared to that of coolant. Over phase 1, inlet manifold gas temperatures were approximately 5°C colder using oil cooled EGR and this resulted in a 6% reduction in NO_x emissions. This result agrees well with the work of Torregrosa et al [20] which suggested a 1% reduction in NO_x per 1°C reduction in inlet manifold temperature. Further analysis of their work showed that this effect should reduce at higher engine loads. Over phase 2, the 12°C reduction in inlet gas temperature resulted in a 5% reduction in NO_x emissions which confirms this trend. Variations in CO emissions also agree with the work from Torregrosa et al. [20]. The measured air mass flow rate and inlet manifold CO₂ concentration were compared for both oil- and coolant-cooled EGR to ensure that there were no changes in EGR rate as a result of improved cooling. Although the oil-cooled EGR seemed to give slightly lower EGR rates under idle conditions, under loaded conditions there were no appreciable differences between the calibrations.

The colder EGR gases was not an intended effect when the test plan was designed but provided a significant benefit in NO_x , which has been traded-off in the optimisation process for improved fuel consumption. This improved effectiveness may be a result of a number of factors, some of which are listed below:

- Oil operated at a colder temperature than coolant during warm-up, therefore providing a larger temperature gradient between the EGR gases and the cooling medium.
- Oil flows may be larger than coolant flows in the respective legs of the circuit, however these were not measured in this work.
- The oil cooled EGR gas path is longer than that for coolant-cooled EGR. This will cause additional ambient heat losses.

As this is an unexpected finding from the work, further investigations into this area are required. However, these results suggest that optimising the thermal management system for maximum EGR gas cooling could provide significant benefits in NO_x that can be traded off for improved fuel consumption via other calibration controls. Clearly there are other constraints that need to be considered in this system such as CO, HC and smoke emissions at very low gas temperatures and the transient response with higher volume gas paths.

5.3 Thermal modelling

All the modelling work presented in this paper was based on the control of each of the actuators of the active thermal management system. However, it would be useful to calculate a model based on the thermal state of the engine that could be applied more generally at the engine design phase.

The inputs for such models need to capture the main variations in engine state that were observed during this study. Thermally, the engine state can be described by upper and lower engine temperatures. Because of the large effect of EGR gas cooling, a descriptor of inlet gas temperature should also be used as well as injection timing. Consequently, polynomial response models for FC and NO_x were calculated using the following inputs. As with the previous response models, these were calculated using 1st and 2nd order terms and 2-way interactions, followed by a stepwise parameter selection approach.

- SOI
- Upper cylinder liner temperature
- Oil main gallery temperature
- Inlet manifold temperature

For each of these models fit statistics were acceptable as the models are not intended to be used as absolute predictors and R^2 and PRESS R^2 ranged between 0.6 and 0.8. Over both phases of the NEDC, NO_x emissions were sensitive to SOI and inlet manifold temperatures which provided no new information from the previous models. The regression analysis did not extract any effects relating to engine thermal state over phase 1, but did identify a small relationship with oil temperature over phase 2 (see figure 17). This is thought to be a result of impacts on piston crown cooling because of the piston cooling jets used in this engine.

The models for fuel consumption showed that SOI and oil temperature had the strongest effects both over phase 1 and 2 (see figure 18). The upper engine temperature did not seem to affect the fuel consumption which is surprising as this would be expected to impact piston/liner friction. Further reflexion suggests that because of its proximity to combustion events, this part of the engine will warm-up fastest and therefore further increases in oil temperature will yield progressively smaller reductions in oil viscosity. Conversely, the crankshaft bearings are much less exposed to combustion heat and warm-up is much slower. Friction reduction in these areas could be significantly more sensitive to changes in oil temperature.

6 Conclusions

The main conclusions from this work are:

- (1) A systems based approach has been demonstrated for the calibration of an active thermal management system in conjunction with other engine controls. A combination of conventional DoE and dynamic testing has achieved reductions in fuel consumption of 2-3% at iso-NO_x conditions over the NEDC.
- (2) The most effective approach for reducing warm-up times and cold start fuel consumption is through reductions in thermal inertia. Coolant flow throttling was used to isolate parts of the coolant circuit during warm-up, with a measured benefit of 1.3%/kg coolant. This approach allows faster warm-up at all locations in the engine. Modulation of heat flows during warm-up can promote warm-up in some areas at the detriment of warm-up in others. The examples in this work allowed a trade-off between upper and lower engine temperatures of about 6°C.
- (3) Inlet gas temperatures have a strong impact on NO_x emissions formation with a 6% reduction for 5°C colder inlet manifold gas temperatures. Benefits in this area may be traded-off against fuel consumption using other calibration actuators such as injection timing. The optimisation of thermal management systems to provide maximum EGR cooling could therefore provide a large potential for fuel consumption gains, but CO, HC, and smoke emissions should also be considered in this process.

(4) The commonly used NO_x correction factor for ambient humidity appeared to be too weak for the engine and humidity variations seen in this work. An empirical correction factor derived from experiments on this engine was used to allow comparison between modelling predictions and validation testing. An in-depth review of these correction factors is recommended.

7 Acknowledgements

The authors would like to acknowledge the funding support for this project received from the Technology Strategy Board. Also, the funding from the collaborating partner, the Ford Motor Company and the support and input from their technical staff are acknowledged, as well as their permissions to publish this paper. The work has been conducted in the Powertrain and Vehicle Research Centre in the Department of Mechanical Engineering at the University of Bath with the assistance of the support and research staff.

8 References

- 1 **Delphi**. Worldwide Emissions Standards: Passenger Cars and Light Duty Vehicles. 2010 available from: www.delphi.com/pdf/emissions/Delphi_PC.pdf (accessed 6th June 2011)
- 2 **ImechE**. Low Carbon Vehicles, Driving The UK's Transport Revolution, 2009.
- 3 **European Commission**, Reducing CO₂ emissions from light-duty vehicles. 2009.

- 4 **Owen, N. and Jackson, N.** A new look at the low carbon Roadmap. *Low-Carbon Vehicles 2009*, pp. 3-14 (Chandos Publishing Ltd., London (UK), 2009).
- 5 **Brace, C.J., Burnham-Slipper, H., Wijetunge, R.S., Vaughan, N.D., Wright, K. and Blight, D.** Integrated Cooling systems for Passenger vehicles, SAE Paper Number 2001-01-1248, 2001.
- 6 **Burke, R.D., Brace, C.J., Hawley, J.G. and Pegg, I.** Review of the systems analysis of the interactions of thermal, lubricant and combustion processes of Diesel engines. *Proceedings of the Institution of Mechanical Engineers Part D- Journal of Automobile Engineering*, 2010, **224**(5), 681-704.
- 7 **Chalgren, R.D.J.** Thermal comfort and Engine warm up Optimization of a low flow advanced Thermal management system, SAE Paper Number 2001-01-0047, 2004.
- 8 **Brace, C.J., Hawley, G., Akehurst, S., Piddock, M. and Pegg, I.** Cooling system improvements - Assessing the effects on emissions and fuel economy. *Proceedings of the Institution of Mechanical Engineers, Part D: Journal of Automobile Engineering*, 2008, **222**(4), 579-591.
- 9 **Ap, N. and Tarquis, M.** Innovative Engine cooling systems comparison, SAE Paper Number 2005-01-1378, 2005.
- 10 **Burke, R.D., Brace, C.J., Cox, A., Lewis, A., Hawley, J.G., Pegg, I. and Stark, R.** Systems approach to the improvement of engine warm-up behaviour.

Proceedings of the Institution of Mechanical Engineers Part D-Journal of Automobile Engineering, 2011, **225(2)**, 190-205.

- 11 Steinparzer, F., Unger, H., Bruner, T. and Kannenberg, D.** The new BMW 2.0 litre 4-cylinder S.I. engine with twin Power Turbo Technology. *32. Internationales Wiener Motorsymposium*, Vienna, 2011).
- 12 Heiduk, T., Dornhofer, R., Eiser, A., Grigo, M., Pelzer, A. and Wurms, R.** The new generation of the R4 TFSI engine from Audi. *32. Internationales Wiener Motorsymposium*, Vienna, 2011).
- 13 Andrews, G.E., Ounzain, A.M., H., L., Bell, M., Tate, J. and Ropkins, K.** The use of a water/Lube oil heat exchanger and enhanced cooling water heating to increase water and lube oil heating rates in passenger cars for reduced fuel consumption and CO₂ emissions during cold start, SAE Paper Number 2007-01-2067, 2007.
- 14 Kunze, K., Wolff, S., Lade, I. and Tonhauser, J.** A systematic analysis of CO₂ reduction by an optimized heat supply during vehicle warm up, SAE Paper Number 2006-01-1450, 2006.
- 15 Burke, R.D. and Brace, C.J.** The Effects of Engine Thermal Conditions on Performance, Emissions and Fuel Consumption, SAE Paper Number 2010-01-0802, 2010.

- 16 **Lewis, A., Brace, C.J., Akehurst, S. and Pegg, I.** Spatially resolved heat flux measurement from a HSDI engine over NEDC (*VTMS 10*, Gaydon, UK, 2011).
- 17 **Burke, R.D., Brace, C.J. and Hawley, J.G.** Critical analysis of on-engine fuel consumption measurement. *Proceedings of the Institution of Mechanical Engineers Part D-Journal of Automobile Engineering*, 2011, **255**(6), 829-844.
- 18 **Bannister, C.D.** Vehicle Emissions Measurement. PhD thesis, (*Department of Mechanical Engineering*, University of Bath, 2007).
- 19 **Lewis, A., Brace, C.J. and Cox, A.** The effect of forced cool down on cold start test repeatability, SAE paper number 2009-01-1976, 2009.
- 20 **Torregrosa, A.J., Olmeda, P., Martin, J. and Degraeuwe, B.** Experiments on the influence of inlet charge and coolant temperature on performance and emissions of a DI Diesel engine. *Experimental Thermal and Fluid Science*, 2006, **30**(7), 633-641.

9 Appendix

9.1 Abbreviations

CA	Crank Angle
CO	Carbon Monoxide
DoE	Design of Experiments

ECU	Engine Control Unit
EGR	Exhaust Gas Recirculation
FC	Fuel Consumption
HC	Unburned Hydrocarbon
NEDC	New European Drive Cycle
NO _x	Oxides of Nitrogen
PRESS	Predicted Residual Sum of Squares
PRT	Pressure Regulated Thermostat
R ²	Coefficient of Determination
SOI	Start of Injection
TDC	Top Dead Centre
TMS	Thermal management system

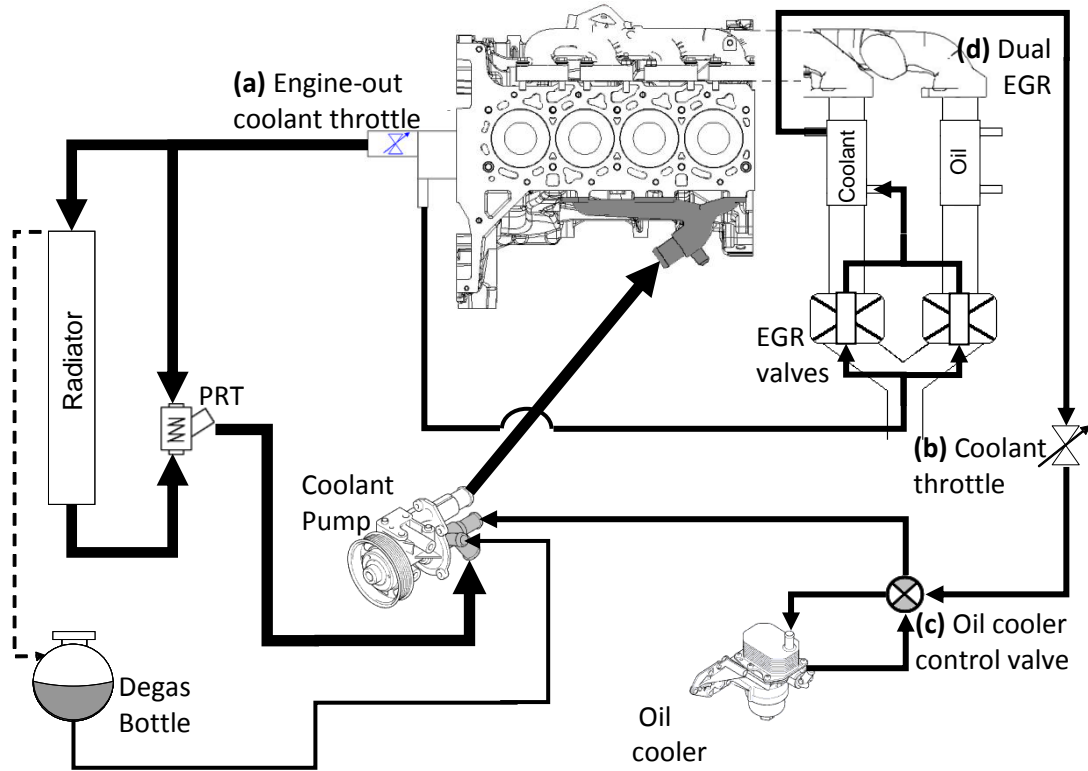

Figure 1: Active thermal management coolant circuit showing a) engine out coolant throttle, b) EGR cooler loop coolant throttle, c) oil cooler and d) oil cooler control valve

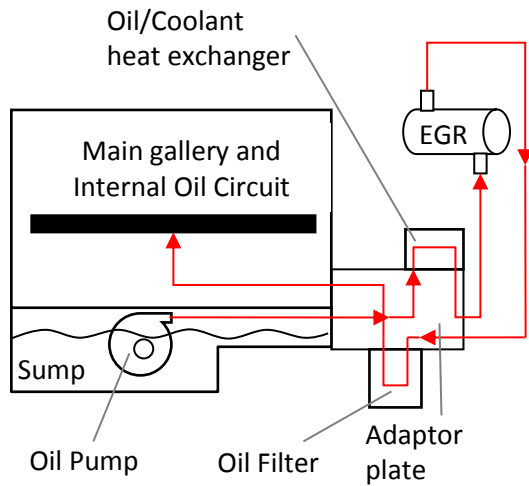

Figure 2: Modified external oil circuit for active thermal management system

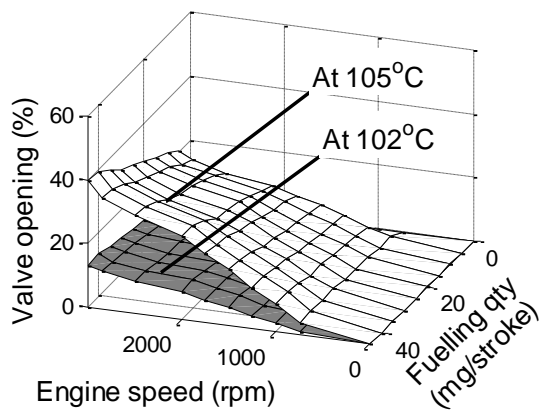

Figure 3: Engine out valve opening maps at engine cylinder head temperatures of 102°C and 105°C. Actual valve opening is interpolated between 0% (fully closed) below 98°C, the maps presented and fully open (100%) above 115°C

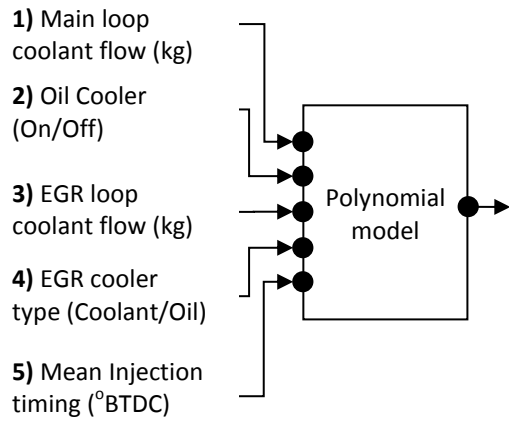

Figure 4: General model structure for describing engine behaviour over each phase of NEDC

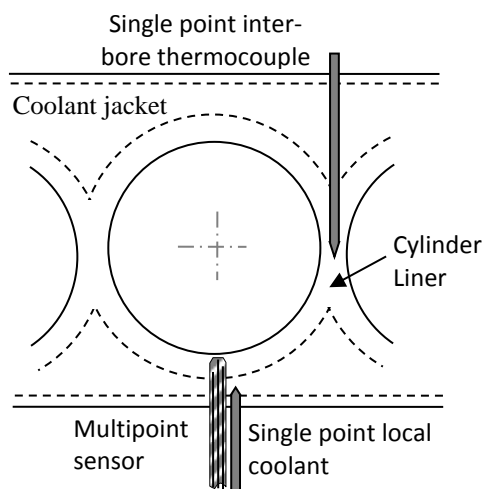

Figure 5: Installation of multipoint and single point thermocouples in the engine block cylinder liner and coolant jacket

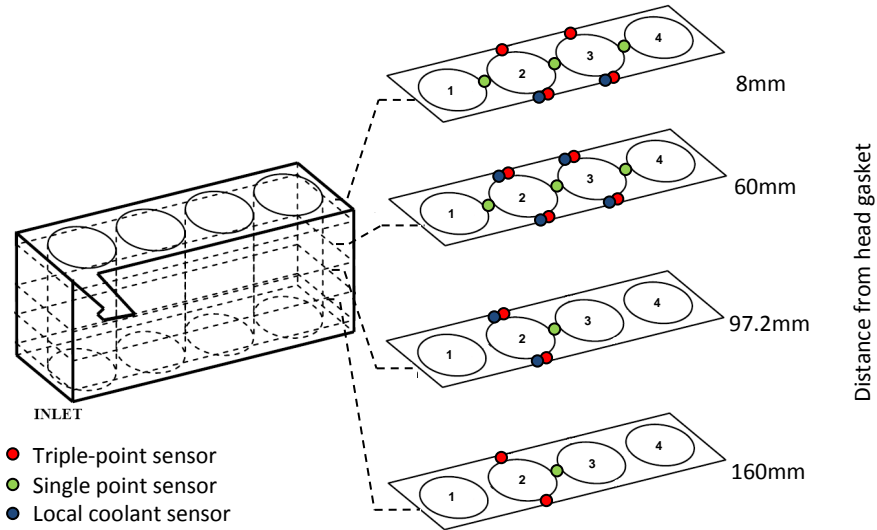

Figure 6: Location of single and multipoint thermocouples in the engine block

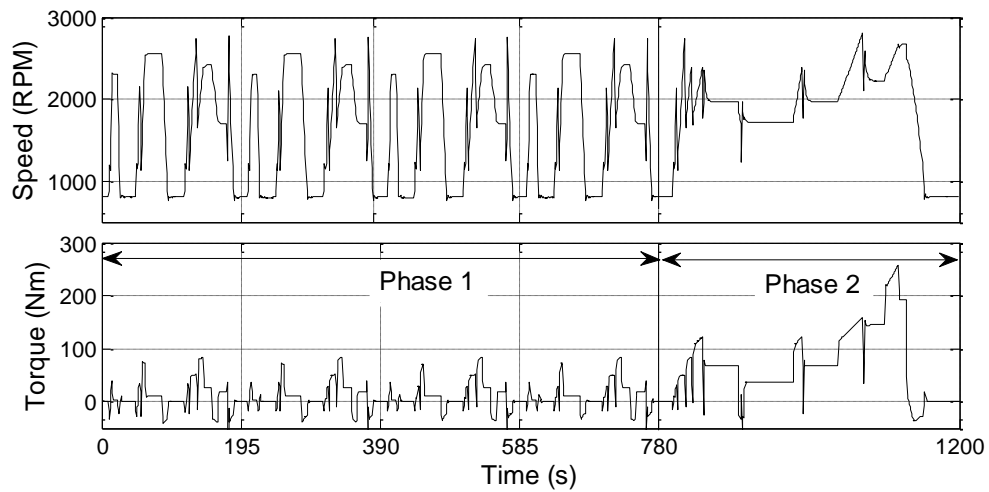

Figure 7: Speed and Torque for NEDC cycle for 2.4L PUMA engine

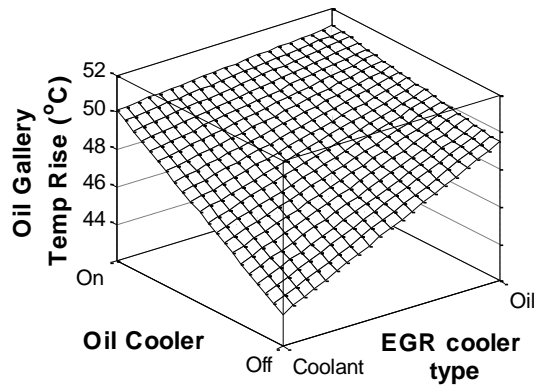

Figure 8: Effects of oil cooler and EGR cooler type on oil main gallery temperatures (Other control variable settings: Engine out coolant throttle: mapped, EGR cooler coolant throttle: max flow, SOI: production)

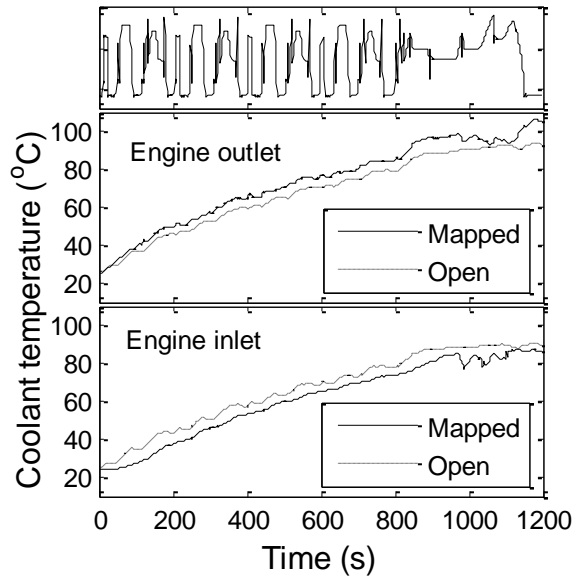

Figure 9: Coolant temperatures at engine inlet and outlet with engine out coolant throttle mapped and open. NEDC engine speed trace also shown as a reference, (Other control variable settings: EGR cooler coolant throttle: max flow, EGR cooler type: coolant, Oil cooler bypass: on, SOI: production)

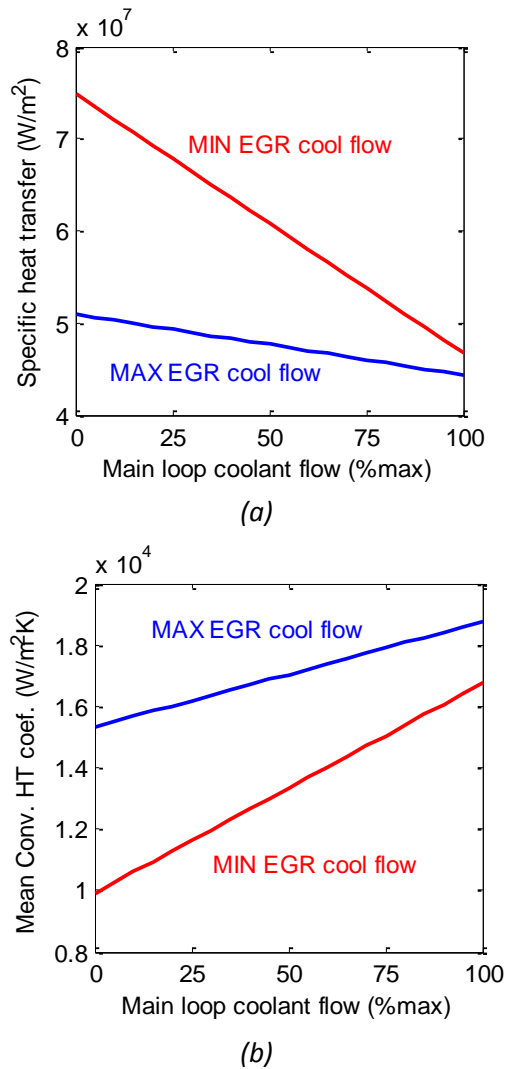

Figure 10: Effect of engine-out coolant flow on (a) heat flux and (b) convective heat transfer coefficient. The lower coolant flow causes increased heat flux because of a larger temperature gradient between the cylinder and colder inlet coolant; however convective heat transfer coefficient is reduced because of lower flow velocity. (Other control variable settings: Oil cooler bypass valve: on, EGR cooler type: coolant, SOI: production)

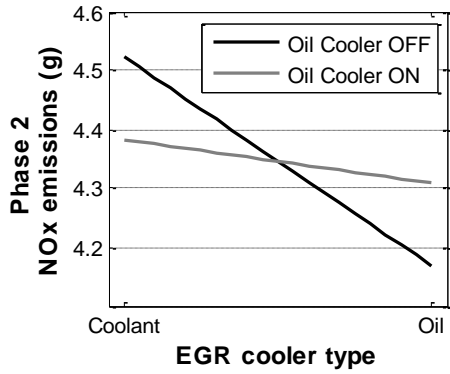

Figure 11: Effect of EGR cooler type on NO_x emissions with oil cooler on or off
(Other control variable settings: Engine out coolant throttle: mapped, EGR cooler coolant throttle: max flow, SOI: production)

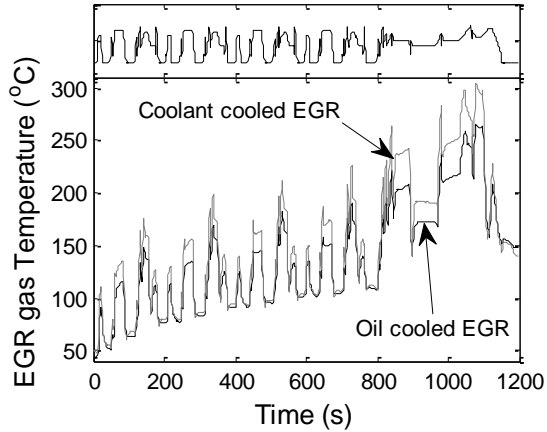

Figure 12: EGR gas temperature after EGR cooler for oil and coolant cooled EGR
(Other control variable settings: Engine out coolant throttle: mapped, EGR cooler coolant throttle: max flow, Oil cooler bypass valve: oil cooler, SOI: production)

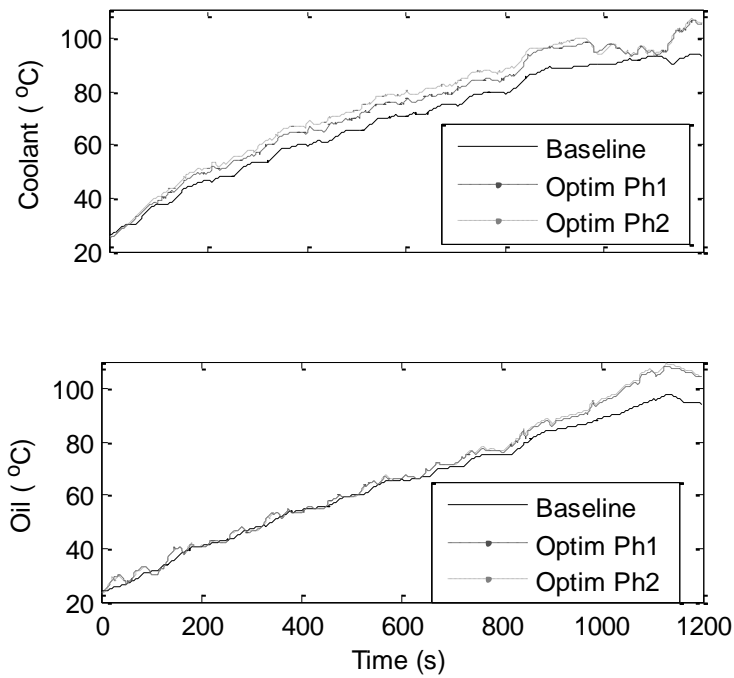

Figure 13: Coolant and oil temperature evolution during cold start NEDC for Baseline, phase 1 optimised and phase 2 optimised calibrations

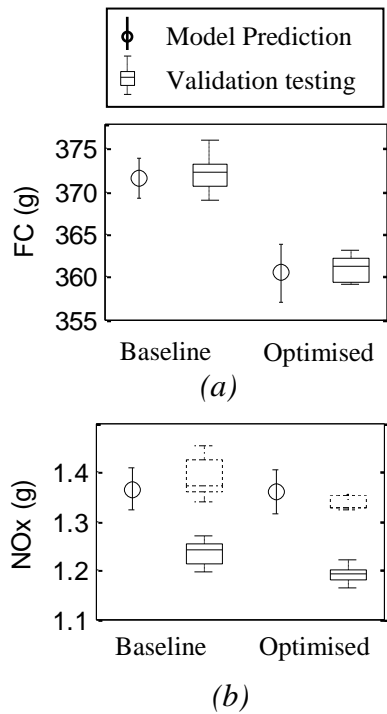

Figure 14: Comparison of predicted and measured (a) gravimetric fuel consumption and (b) NO_x showing model prediction confidence and validation measurement spread (dotted box on NO_x results refers to results adjusted using empirical correction factor for changes in ambient humidity).

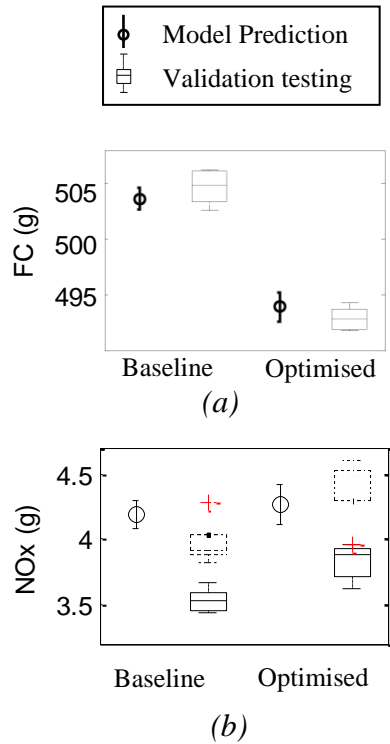

Figure 15: Comparison of predicted and measured (a) gravimetric fuel consumption and (b) NO_x showing model prediction confidence and validation measurement spread (dotted box on NO_x results refers to results adjusted using empirical correction factor for changes in ambient humidity).

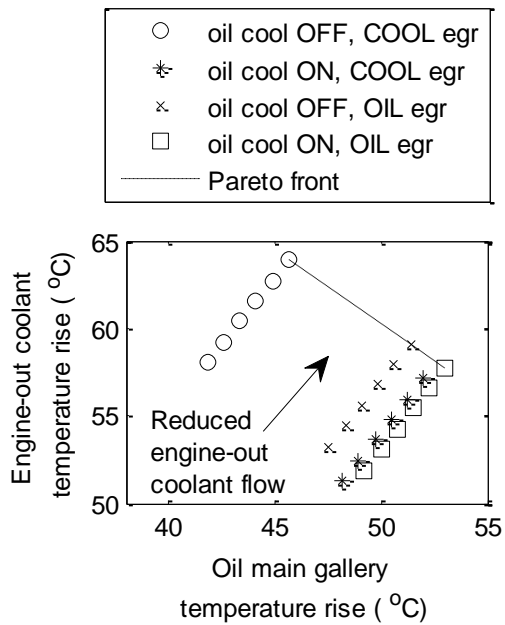

Figure 16: Coolant and Oil and upper engine warm-up trade-off resulting from oil cooler and EGR cooler calibration

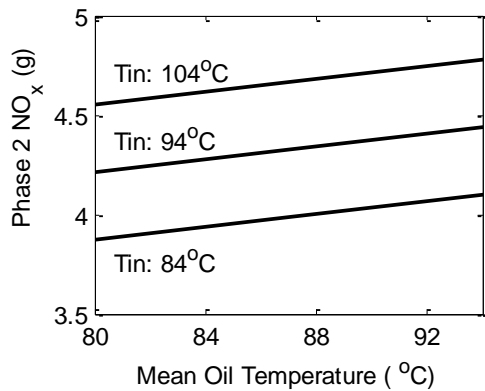

Figure 17: Effect of inlet gas temperature and oil temperature on phase 2 NO_x emissions

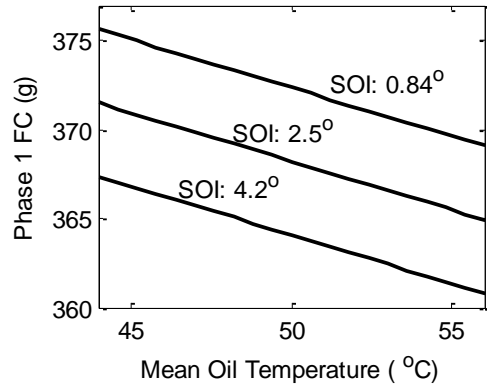

Figure 18: Effect of injection timing and oil temperature on phase 1 fuel consumption