

University of Groningen

Challenges for pulmonary delivery of high powder doses

Sibum, Imco; Hagedoorn, Paul; de Boer, Anne Haaije; Frijlink, Henderik Willem; Grasmeijer, Floris

Published in:
International Journal of Pharmaceutics

DOI:
[10.1016/j.ijpharm.2018.07.008](https://doi.org/10.1016/j.ijpharm.2018.07.008)

IMPORTANT NOTE: You are advised to consult the publisher's version (publisher's PDF) if you wish to cite from it. Please check the document version below.

Document Version
Publisher's PDF, also known as Version of record

Publication date:
2018

[Link to publication in University of Groningen/UMCG research database](#)

Citation for published version (APA):

Sibum, I., Hagedoorn, P., de Boer, A. H., Frijlink, H. W., & Grasmeijer, F. (2018). Challenges for pulmonary delivery of high powder doses. *International Journal of Pharmaceutics*, 548(1), 325-336.
<https://doi.org/10.1016/j.ijpharm.2018.07.008>

Copyright

Other than for strictly personal use, it is not permitted to download or to forward/distribute the text or part of it without the consent of the author(s) and/or copyright holder(s), unless the work is under an open content license (like Creative Commons).

Take-down policy

If you believe that this document breaches copyright please contact us providing details, and we will remove access to the work immediately and investigate your claim.

Downloaded from the University of Groningen/UMCG research database (Pure): <http://www.rug.nl/research/portal>. For technical reasons the number of authors shown on this cover page is limited to 10 maximum.



Challenges for pulmonary delivery of high powder doses

Imco Sibum*, Paul Hagedoorn, Anne Haaije de Boer, Henderik Willem Frijlink, Floris Grasmeijer

Department of Pharmaceutical Technology and Biopharmacy, Faculty of Science and Engineering, University of Groningen, Groningen, The Netherlands



ARTICLE INFO

Keywords:

High dose pulmonary delivery
Dry powder inhaler
Inhaler design
Drug formulation
Inhalation

ABSTRACT

In recent years there is an increasing interest in the pulmonary delivery of large cohesive powder doses, i.e. drugs with a low potency such as antibiotics or drugs with a high potency that need a substantial fraction of excipient(s) such as vaccines stabilized in sugar glasses. The pulmonary delivery of high powder doses comes with unique challenges. For low potency drugs, the use of excipients should be minimized to limit the powder mass to be inhaled as much as possible. To achieve this objective the inhaler design should be adapted to the properties of the API in order to achieve a compatible combination of the drug formulation and inhaler device. The inhaler should have an appropriate powder dosing principle for which prefilled compartments seem most appropriate. The drug formulation should not only allow for accurate filling of these compartments but also enable efficient compartment emptying during inhalation. The dispersion principle must have the capacity to disperse considerable amounts of powder in a short time frame that allows the powder to reach the deep lung. Last, but not least, the inhaler should be simple and intuitive in use, be cost-effective and exhibit accurate and consistent, preferably patient independent, pulmonary delivery performance.

1. Introduction

Pulmonary administration of low dose active pharmaceutical ingredients (APIs) as dry powders has been used widely to treat various diseases for about 50 years. Their use is aimed primarily at the treatment of asthma and chronic obstructive pulmonary disease (COPD) and the drugs involved are mostly given in a dose range of 6 (formoterol)–500 µg (fluticasone propionate) (Smith and Parry-Billings, 2003). In recent years an increasing interest has developed in the delivery of low potency drugs like antibiotics via the pulmonary route. These APIs often have to be administered in much higher doses to achieve their therapeutic effect. Doses for such drugs are in the milligram-range without excipient(s) and they may even extend to the gram-range, as shown in Table 1. An increasing interest in pulmonary delivery also exists for high potency, low dose drugs that require a notable amount of excipient in the respirable particles. This too may result in a high powder dose, and therefore, in similar challenges regarding their formulation and dispersion as the low potency, high dose drugs. As such, both types of drug are regarded as ‘high (powder) dose drugs’ in this review. This is further elaborated on in Section 2, where a definition of high powder doses is presented.

The increasing interest in the pulmonary delivery of high dose drugs is the result of significant potential advantages of this route of administration compared to the oral or parenteral routes. These advantages include a targeted delivery to the lungs with lower systemic side effects

at higher local concentrations, which increases the therapeutic efficacy as a result. In addition, a faster response can be obtained both locally and systemically. Furthermore, no or only limited first pass metabolism, the capacity for large molecules to be absorbed in high doses in the lower respiratory tract, and the ability to trigger a local immunological response which can be beneficial for vaccines are other advantages of pulmonary delivery (Hoppentocht et al., 2014a; Labiris and Dolovich, 2003; Tonnis et al., 2013). Finally, macrophages in the lungs may be targeted, which can harbor infectious bacteria such as *Mycobacterium tuberculosis* (Patel et al., 2015).

High dose inhaled antibiotics like colistin and tobramycin dry powder products are already on the market, and further research is performed on amikacin, kanamycin, gentamycin and isoniazid, amongst others. The colistin and tobramycin products are used in the treatment of cystic fibrosis patients whereas the other antibiotics are investigated for use in diseases such as tuberculosis (TB) and bronchiectasis (Davis et al., 2007; Eldon et al., 2008; Luyt et al., 2009; Sacks et al., 2001; Turner et al., 1998). For anti-fungal compounds multiple dry powder formulations have been described. For instance, amphotericin B and voriconazole have been successfully formulated and tested *in vitro*, with animal studies being planned for both formulations (Arora et al., 2015; Shah and Misra, 2004). However, not only antimicrobial drugs have been taken into consideration. Also liposomal tacrolimus and cyclodextrin complexes of cyclosporin A have been investigated as dry powder for the prevention of organ rejection after lung transplants

* Corresponding author at: University of Groningen, Department of Pharmaceutical Technology and Biopharmacy, Antonius Deusinglaan 1, 9713 AV Groningen, The Netherlands.
E-mail address: i.sibum@rug.nl (I. Sibum).

<https://doi.org/10.1016/j.ijpharm.2018.07.008>

Received 15 March 2018; Received in revised form 20 June 2018; Accepted 1 July 2018
Available online 02 July 2018

0378-5173/ © 2018 The Authors. Published by Elsevier B.V. This is an open access article under the CC BY license (<http://creativecommons.org/licenses/by/4.0/>).

Table 1

Several APIs that may benefit from high dose pulmonary administration. The doses reported in DPIs, the doses used in studies, either with dry powder (dp) or nebulized (neb), and the estimated dry powder dose required for these APIs are given. When a dose was reported based on the patients' weight, the average weight of a European, 70.8 kg, was used to calculate the total dose. A conversion factor of 2.5 was used to calculate the expected dry powder dose required from the nebulized doses. This factor was based on the difference in dose between nebulized and dry powder formulations of tobramycin and colistin. Estimated dry powder doses from nebulization were placed in ranges of 5–50 mg, 50–100 mg, 100–200 mg, 200–500 mg, 500–1000 mg, and 1000–2000 mg. References included: (Ahmed et al., 1999; Andersen et al., 2017; Corcoran et al., 2014; Davis et al., 2007; Ehrmann et al., 2008; Eldon et al., 2008; Groves et al., 2010; Hagedoorn et al., 2017; Hayes et al., 2010; Keating, 2013; Konstan et al., 2011; LeWitt et al., 2016; Lipp et al., 2016; Luinstra et al., 2015; Luyt et al., 2009; Quon et al., 2014; Sacks et al., 2001; Schuster et al., 2013; Turner et al., 1998).

API	Dose inhaler (mg)	Dose used in studies (mg)	Dry powder dose required (mg)
tobramycin (TOBI)	28 mg	112 mg dp	112 mg
colistin (colobreathe)	125 mg	125 mg dp	125 mg
colistin (Twincer)	55 mg	55 mg dp	55 mg
loxapine	5–10 mg	5–10 mg dp	5–10 mg
levodopa	40 mg	35–50 mg dp	35–50 mg
voriconazole	20 mg	40 mg neb	5–50 mg
amikacin		400–4248 mg neb	100–2000 mg
kanamycin		80–750 mg neb	100–500 mg
gentamycin		80 mg neb	5–50 mg
amphotericin B		25–50 mg neb	5–50 mg
tacrolimus		20 mg neb	5–50 mg
cyclosporin A		100–300 neb	50–200 mg
low molecular weight heparin		35–140 mg neb	5–100 mg

(Chougule et al., 2007; Matilainen et al., 2006). Cyclosporin A has also been described for the treatment of asthma, COPD, cystic fibrosis and lung cancers (Cun et al., 2015). Other locally acting drugs for which high dose pulmonary administration may be useful include chemotherapeutic drugs in lung cancer (Zarogoulidis et al., 2012) and drugs against pulmonary arterial hypertension (Ghanbarzadeh et al., 2016; Wang et al., 2016).

For systemically acting drugs, the fast systemic absorption that may be achieved via the pulmonary route is for instance beneficial in the treatment of off periods in Parkinson's disease with levodopa or the acute treatment of agitation with loxapine (Keating, 2013; Luinstra et al., 2015). In some cases the low metabolic activity of the pulmonary route or its permeability to large molecules of several kilodaltons in size (such as small proteins) are of particular interest. Examples of the latter include the systemic delivery of calcitonin for calcium homeostasis and bone remodeling, low molecular weight heparin against deep vein thrombosis, and insulin for type 1 and type 2 diabetes. (Bai and Ahsan, 2009; Barnett, 2004; Yang et al., 2012).

Many of the new drugs taken recently into development are biopharmaceuticals and most examples within this new class of drugs are large-molecule compounds, e.g. peptides proteins, antibodies and nucleic acids (Agrawal, 2015). The majority of these new compounds are investigated for cancer therapy or treatment of neurological diseases, infections and immunological disorders. But also compounds against cardiovascular disease, mental health disorders, diabetes and HIV/AIDS are in various phases of clinical studies. Most of them need to act systemically and one of the greatest challenges is to get them into the blood stream as large biopharmaceutical molecules cannot effectively be absorbed by the lining of the human intestines (Renukuntla et al., 2013). Typically, their bioavailability after oral administration is less than 1–2% and pulmonary delivery may bypass this problem. A plethora of devices for drug delivery to the respiratory tract is available and they can be divided into nebulizers, metered dose inhalers (MDIs)

and dry powder inhalers (DPIs). However, most of the currently marketed inhalation devices are not designed for high doses and are, therefore, not suitable for this purpose. For instance, none of the currently available MDIs can deliver the required high drug amounts as their metering chambers generally have a maximum volume of around 100 µl (Stein et al., 2014). Besides, many biopharmaceuticals are not stable in either solution or suspension, and as such it should be avoided to formulate them in liquids (Hinrichs et al., 2001; Wang et al., 2012). Although high doses can be dispersed with nebulizers, these devices have many disadvantages as well. APIs are in solution or have to be reconstituted in water before use, which either requires a cold chain to keep them stable or clean water, respectively (Hoppentocht et al., 2014b). Furthermore, high shear forces during droplet formation may cause stability problems for biopharmaceuticals (Cun et al., 2015; Khatri et al., 2001). Other disadvantages of nebulizers are the long administration time and the need to clean them after each administration and/or disinfect them on a regular basis. Most nebulizers are voluminous and need electricity or pressurized air for their operation which limits the mobility of the patient (de Boer and Hagedoorn, 2015; Hoppentocht et al., 2014a; Tonnis et al., 2013). Lastly the residual liquid left after administration can be a problem. This residue can amount up to 30% of the total volume and, as a result of evaporation, an even higher percentage of the total drug dose. This increases costs, which can be a significant disadvantage for expensive APIs like biopharmaceuticals (Tonnis et al., 2013).

With dry powder inhalers (DPIs) several of the problems mentioned above may be omitted. The dose is not necessarily limited by the size of the dose compartment and many APIs are stable in the dry state or can be stabilized in excipient matrices like insulin or trehalose. Consequently, powder formulations for the drugs do generally not need a cold chain for transport and storage (Hinrichs et al., 2001; Hoppentocht et al., 2014a; Parumasivam et al., 2016). Moreover, they allow for fast administration, require limited maintenance or cleaning, they can be made disposable (e.g. for single use) and many show a low inhaler retention. Commercially successful DPI developments for pulmonary administration of high dose drugs are as of yet scarce however.

The scarcity in high dose DPI developments is reflected by the lack of studies and literature reviews on this subject. It might be explained by the challenges encountered in achieving a good tuning between DPI design and high dose formulation properties. Generally, high dose formulations are very cohesive and difficult to measure and disperse reproducibly into suitable aerosols for inhalation. This may put high demands on the inhaler dose (measuring) and dispersion principles. This review aims to aid in that regard by giving an extensive overview of the current state of the art concerning formulation techniques and devices currently in use. It also presents considerations for DPI design and what knowledge gaps remain for the further improvement of high dose dry powder aerosol delivery.

2. Differences between low and high dose delivery

For a better understanding of the inhaler requirements for high dose powder administration to the respiratory tract a comparison with low dose delivery may be helpful. It all starts with the definitions for high and low doses and to the authors' best knowledge no unambiguous definition has yet been given in literature as to what constitutes low and high pulmonary doses. Low dose drugs for inhalation in the microgram-range (< 1 mg) are usually mixed with much coarser lactose carrier particles to improve their dose reproducibility. During the mixing process, the micronized drug particles adhere to the surface of the carrier particles, thereby constituting so-called adhesive mixtures, also named interactive or ordered mixtures (Hersey, 1975; Staniforth, 1987). The mass of adhesive mixture dispersed by currently marketed inhalers is usually in the range between 10 and 25 mg. There is a limit to the drug quantity that can be processed in adhesive mixtures. For the sake of content uniformity and stability, they can contain maximally

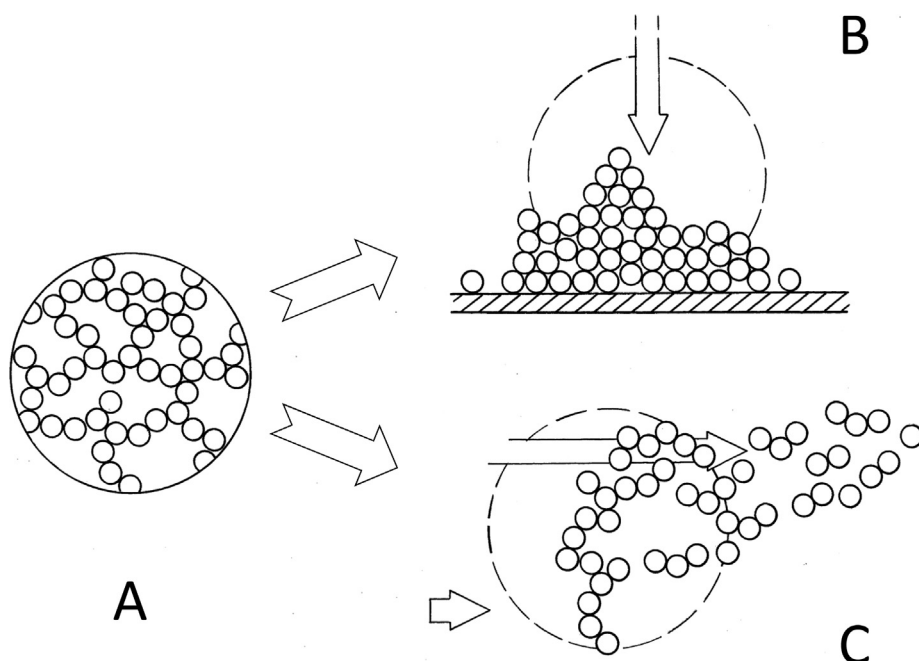

Fig. 1. (A) Schematic two-dimensional presentation of the void space in a powder with monosized particles having a porosity of 70%, showing the room for particle re-arrangement upon the application of an external force. (B) Densification and compaction, instead of dispersion, of the powder in Fig. 1A upon collision of a pellet with an inhaler wall. (C) Dispersion of the same powder in two impinging air flows by internal shear, as in a circulation chamber with tangential bypass channels.

around 5–10% of drug, depending on the type of carrier particles used (Grasmeijer et al., 2015). The amount of drug in 25 mg adhesive mixture is, therefore, maximally 2.5 mg. At higher drug concentrations, multiple drug layers on the carrier surface and drug pellets without carrier nucleus may be formed, which are mechanically unstable and negatively affect dose reproducibility. Practically, drug concentrations in marketed products are limited to the range between 0,1 and 4% to minimize the risk of dose inconsistency (Grasmeijer et al., 2013).

On the basis of the previous reasoning, one should consider inhaled drug doses larger than 2.5 mg as high. Drug doses of 2.5 mg and more should not be administered as an adhesive mixture, because it would imply the inhalation of 62.5 mg powder (for a 4% mixture) or even considerably more (for mixtures with less than 4% drug or for larger drug doses). Considering the size fraction of the carrier particles this would result in severe deposition of carrier particles and drug bound to these particles in the throat where cough reactions are induced and the drug may cause adverse local side effects. It would also require multiple inhalations for a single dose which is a burden for the patient and results in a demotivation for adhering to the therapy.

Micronized drugs in the absence of freely flowing carrier particles have basically different properties compared to adhesive mixtures. By not being attached to a carrier surface the intrinsic properties of the drug particles govern the powder behavior. Powders consisting of pure micronized particles for inhalation have very poor flow properties and tend to form large lumps without further processing. This affects the dose measuring into or by the inhaler, the drug entrainment from the dose (measuring) compartment, the aerosolization and dispersion performance and the drug retention in the inhaler. To large extent the difference in properties compared to those of adhesive mixtures is the same for pure drug particles and drug-excipient composite particles as obtained for instance from spray drying. It is primarily the micronized state that determines the high co- and adhesiveness of the powder. Therefore, low dose drugs administered in quantities smaller than 2.5 mg that need for instance stabilization with an excess of sugar glasses (e.g. biopharmaceuticals) or are co-processed with large amounts of excipients for other reasons should be considered as high dose drugs too in this respect. It is rather the type of formulation (adhesive mixture or micronized powder and soft pellets respectively) than the amount of drug in the formulation that determines what a high dose is. The properties of high dose drugs are also rather independent of

further processing of the drug particles. For instance, pelletization can improve the flow properties and the aerosolization behavior (entrainment), but dispersion performance and retention behavior remain largely the same in the same type of inhaler. Most high dose drugs or drug formulations, particularly those prepared by spray drying, are often also highly hygroscopic. This further increases the co- and adhesiveness of the powders. Some behavior aspects of inhalation powders are intrinsic to the high masses or volumes in which they are given. Large cohesive powder quantities can be difficult to entrain from the dose compartment, overload dispersion principles and build up thick powder layers on various inhaler parts, particularly when the powders are not only highly adhesive, but also highly compactible.

Because of all these differences, different dispersion principles may be needed to convert carrier based adhesive mixtures and cohesive powder masses effectively into suitable aerosols for inhalation. The drug-to-carrier interaction forces in adhesive mixtures are generally high by the action of the mixing forces during preparation. This may result in firm pressing of the drug particles against the carrier surface as mixing times are often very long to achieve the desired content uniformity of the blend. Drug particles may also find shelter in carrier surface irregularities from the separation forces of the drag and lift type (de Boer et al., 2012; Grasmeijer et al., 2015). Agglomerates of cohesive micronized powders mostly have porosities over 70–80% (Trofast et al., 2002). This means that the average coordination number in such agglomerates (number of contact points per particle) is very low and that there exists an abundance of free space for particle re-arrangement under the influence of external forces (Fig. 1A). These differences seem to make inertial dispersion or separation forces, as from particle collisions onto the inner walls of circulation chambers (Fig. 1B), more appropriate for adhesive mixtures. In contrast, internal shear, as for instance in turbulent or impinging air streams, may be more effective for cohesive agglomerates (Fig. 1C). As a result of all these differences compared to adhesive mixtures for low dose drugs, the pulmonary administration of high dose drugs gives rise to several specific challenges. They will be elaborated on in further detail in the following sections of this manuscript.

3. The properties of particles and powders for inhalation

Powders for pulmonary administration have to fulfill several

criteria. A basic requirement is that they should contain the drug particles in an aerodynamic size distribution between 1 and 5 μm (or even more preferably between 1 and 3 μm) to obtain substantial central and deep lung deposition (Labiris and Dolovich, 2003). Further requirements relate to good stability, maximal emission from the inhaler (i.e. low retention) and adequate dispersion into the aerosol. Different forces govern the interaction between powder particles and, as such, the dispersibility of the powder itself. They include electrostatic forces, capillary forces and Van der Waals forces (Castellanos, 2005). The physics of these forces have been described extensively elsewhere and are not the scope of this manuscript (Castellanos, 2005; Visser, 1989). Other forces can be present too but they play an ancillary role and are deemed irrelevant for dry powder inhalation. Van der Waals forces are generally the most dominant types of forces (by number) between particles in dry powders (Castellanos, 2005). Van der Waals forces depend on multiple factors. These are the chemical properties of the API in question, and the physical properties of the particles prepared, including their size and shape distribution, surface morphology (e.g. rugosity, smoothness, purity), density, and water content. The physical properties determine to large extent the magnitude of the Van der Waals forces and modifying and/or controlling them is the rationale for different particle engineering techniques.

It has to be recognized that the interparticulate forces in micronized powders (as for high dose drugs) can play a different role than in adhesive mixtures (for low dose drugs). This is primarily the result of the differences in particle size distribution (PSD) between the carrier particles and drug particles. As already mentioned, the carriers in adhesive mixtures for low dose drugs have mostly fair to good flow properties. In micronized powders cohesion forces (e.g. van der Waals forces, electrostatic forces and capillary forces) are dominant over the forces of gravity, which provides these powders their poor flow properties and strong agglomeration tendency. As a result, accurate dose measuring of micronized powders may be much more problematic than that of adhesive mixtures. The differences in powder properties, particularly the difference in cohesiveness may, therefore, require basically different design solutions for high dose drug inhalers, as will be further explained in Section 6.

Van der Waals (adhesion) forces can also exist between particles and inhaler walls. They can lead to a high powder retention in the inhaler, even when the emptying of the dose compartment is rather complete. In addition to Van der Waals forces electrostatic forces may contribute to inhaler retention, as the displacement of particles through the inhaler is accompanied with repeated particle-wall contacts. Transfer of Coulombic charge between particles and plastic parts of the inhaler during moments of contact is the reason for cumulating opposite charges between the powder and the inhaler walls. Particles can also be charged in the air stream, particularly when the velocity difference between the air and airborne particles is considerable. Furthermore, particles can also be charged as a result of particle to particle collisions. Also in this respect there exists a fundamental difference between low and high dose formulations as will be elaborated in Section 6.

4. Techniques for the preparation of inhalation particles

Several techniques exist for the preparation of inhalation powders, which differ amongst other things in cost, scalability, compatibility with the API and the way they enable rational particle engineering.

Milling has been used extensively as a top down approach to obtain particles in the desired size range for inhalation but a considerable knowledge gap remains where particle breakage is concerned (Shah et al., 2017). As a result, milling is not particularly suited for the rational engineering of particles in terms of their shape, density or surface properties. Nevertheless, milling can change the particle shape and surface properties (Luner et al., 2012), which affects the hydrophobicity and flowability of the powder particles (Feeley et al., 1998; Heng et al., 2006). As explained in previous sections, this is especially relevant for

high dose powders which do not rely on coarse excipients for satisfactory flowability and entrainment. An advantage of milling is that it is cheap, reproducible and relatively easy to scale up. Different milling techniques result in different stresses on the particles, which may result in different surface energies. For example, Luner et al. compared the wet and dry milling of succinic acid and sucrose. For both materials, wet milling resulted in a higher surface energy than dry milling (Luner et al., 2012). This may be relevant also when APIs are concerned that are particularly sensitive to mechanical stress.

Another often-used technique to produce powders for pulmonary administration is spray drying. Spray drying is a bottom-up approach which is particularly suited for particle engineering. Particle engineering via spray drying has been extensively reviewed elsewhere, and, therefore, only a short overview will be given here (Vehring, 2008). Spray drying is a very well-scalable process which enables fine control over multiple process parameters and a wide range of particle properties. Without the use of excipients, the density of the powder particles and, as a result, that of the powder bulk can be changed. Of course, for high dose drugs there is a limit to the powder volume that can be dispersed and inhaled, which also puts a limit to the suitable particle and powder density for each API. Furthermore, the particle size distribution, surface morphology (smooth or corrugated), water content and particle shape can be controlled. However, for thermolabile drugs or drugs that are prone to sublimation, particle engineering options by spray drying may be limited due to the restricted outlet temperature range (Sibum et al., 2016). Additionally, spray dried particles are often completely amorphous. Amorphous particles generally tend to be more hygroscopic and have a higher surface energy, which makes them more ad- and cohesive. Furthermore, the physico-chemical stability of amorphous powders is generally lower than that of their crystalline counterparts.

A relatively new method for the production of micron-sized powder particles is supercritical fluid technology. Supercritical fluid technology is an umbrella term for multiple techniques that use supercritical fluids in one form or another. The techniques presented most frequently in literature are CO_2 assisted nebulization, supercritical antisolvent technique and SCF assisted nebulization drying. All of these techniques use supercritical liquid CO_2 , mainly because of its low critical temperature and environmental friendliness (Carpenter et al., 2002; Mawson et al., 1997; Sellers et al., 2001; Sievers et al., 2001).

Supercritical fluid technology has several advantages and disadvantages. The most important advantages are that the APIs are not exposed to high temperatures and their physical form and surface morphology can be controlled. However, the high pressure needed for nebulization can have a negative effect on the activity of biopharmaceuticals (Winters et al., 1996). Furthermore, viral inactivation has been described, and therefore, it might not be a suitable technology for vaccine production (Dillow et al., 1999). Lastly, organic solvents are sometimes needed to increase the solubility of the API in the supercritical fluid. This is environmentally unfriendly and might result in aggregation as well. It has been shown that the inclusion of DMSO in the supercritical fluid induces the development of intermolecular β -sheet aggregation (Winters et al., 1996).

Another new technique that has been used for particle engineering is particle replication in non-wetting templates (PRINT), also referred to as 'micro molding'. Pure API, or API with excipients, is pressed into a micro-mold. When this micro-mold is removed, particles with the size and shape of the mold cups are obtained. This results in a powder with a uniform particle size, shape and surface morphology. It appears suitable for the pulmonary delivery of biopharmaceuticals as it has been shown that particles with an MMAD of 3 μm containing 50% bovine DNase retained their activity (Mack et al., 2012). However, more research should be performed to ascertain if this is a suitable preparation method for high dose APIs, not in the least regarding its scalability.

Spray freeze drying has also been used to generate particles in an inhalable range. However, spray freeze drying results in highly porous

particles which increase the total powder volume to be administered (Wanning et al., 2017). This is unfavourable for high powder doses and as such this technique is not further discussed in this review.

Further processing of the resulting particles to impart different properties to the powder, such as pelletization, can be performed. However, in practice this is hardly done. It can be a result of other downstream processes. For example, powder filling with a drum filler may result in pelletization of the powder (Grasmeijer et al., 2017).

5. Formulation of high dose drug-excipient combinations for pulmonary administration

The extent to which drug particles have to be formulated depends on the API in question and the dry powder inhaler used. In its most basic form, formulation only entails comminution of the particles into the desired size distribution. However, biopharmaceuticals likely need to be stabilized first by the use of excipients, and excipients may also be needed to attain an acceptable level of dispersion with the DPI that has been selected for their administration. The extent to which powders have to be formulated also dictates what kind of technology will be most suitable for their preparation. For example, if particles only have to be obtained in the correct particle size distribution, and the API is not very sensitive to mechanical stress, milling would be ideal as it is a simple one-step process. However, for many drug-inhaler combinations simple milling will yield a product that is unsuitable for inhalation.

Much of particle engineering for the drug particles can be done by simply changing processes or process parameters in techniques such as spray drying and supercritical fluid drying. In situations where this is not effective, excipients may offer additional possibilities to obtain the desired powder properties. Particle engineering by varying the process conditions or using excipients may for instance be desired for:

- stabilizing biopharmaceuticals and vaccines;
- increasing drug solubility;
- decreasing or increasing (the rate of) moisture uptake;
- targeting macrophages or avoiding clearance by them;
- increasing muco-adhesion;
- adding a delayed or controlled release profile;
- improving the dispersion of the powder.

Although all of these applications are of interest for low dose drugs as well, some are especially relevant where high dose drugs are concerned. Therefore, they are briefly reviewed and discussed in terms of their feasibility.

Biopharmaceuticals and vaccines can be stabilized by encapsulation in amorphous sugar matrices (Hinrichs et al., 2001; Tonnis et al., 2013). For instance, inulin was used in a ratio of 200:1 (inulin:vaccine) to produce an influenza vaccine suitable for pulmonary administration. One mg of powder of this pulmonary vaccine offered a similar immunization as a single I.M. dose in mice (Audouy et al., 2011). Other common sugar:protein ratios are 5:1 and 10:1. Of course, such a high fraction of excipient is only feasible if the pure vaccine is potent enough to prevent an extraordinarily high formulated powder mass for a single dose. The same is true for cyclodextrins, which may be used to increase drug solubility (Loftsson, 2002). Mohtar et al. developed a fisetin dry powder suitable for pulmonary administration. Cyclodextrin was used in a molar ratio of 2:1 (fisetin:cyclodextrin) to increase the dissolution rate 8 fold (Mohtar et al., 2017). Fisetin, like all APIs, needs to dissolve first in the lung fluid before it can have its anticancer effect.

L-leucine has been used to decrease the moisture uptake by powders. Li et al. showed that 10–20% of L-leucine could protect disodium cromoglycate from moisture induced crystallization and reduce water sorption by more than half (Li et al., 2016).

In contrast, Tian et al. used excipients to increase water uptake in excipient enhanced growth formulations. (Tian et al., 2013). This causes particles to absorb water from the moist air during transport

through the lungs, increasing their size and deposition efficiency. In one of their studies they used 50 or 75% of sodium chloride as hygroscopic excipient. Particles with an initial geometric diameter of 900 nm increased in size to around 5–6 µm in the lungs, which increased their lung deposition 20–30-fold when compared to conventional formulations. The high fraction of excipient required for this particular application implies that it will only be feasible to administer an excipient enhanced growth formulation in a single inhalation maneuver for drugs dosed up to approximately 15–25 mg in their pure form.

Vyas et al. produced liposomes with rifampicin, which were targeted to macrophages by the use of O-steroyl amylopectin. With this formulation the viability of *Mycobacterium smegmatis* within macrophages went down by 28% compared to rifampicin in neutral liposomes, which was attributed to the targeting effect (Vyas et al., 2004). On the other hand, inclusion of cholesterol or sphingomyelin in liposomes lowers their uptake by macrophages and may prolong their residence time in the lungs (Patel et al., 2015). A major disadvantage of working with liposomes is the increase in mass that is to be inhaled for a full dose. For example, liposomes have been formulated that contain less than 10% of isoniazid (Rojanarat et al., 2011). Isoniazid is dosed up to 300 mg IM once daily. Assuming that the isoniazid liposomes are just as effective as an IM bolus, 3 g would have to be inhaled to obtain the same effect. When a DPI can deliver 50 mg of powder in a suitable particle size distribution per inhalation, at least 60 inhalation maneuvers would have to be performed. This of course disregards the potentially higher efficiency of local and targeted delivery. Furthermore, multiple inhalation maneuvers might still be preferred over a single injection.

Nano- or microparticles prepared using biodegradable polymers have the same disadvantage. For example, Sung et al. produced a rifampicin sustained release formulation by using porous nanoparticle-aggregate particles (Sung et al., 2009). These PLGA nanoparticles self-assembled into porous microparticles suitable for inhalation. The highest fine particle fraction found was $44.7 \pm 2.3\%$ and the highest drug load found was $10.0 \pm 0.1\%$. Therefore, this formulation technique likely increases the mass and volume of the powder too much to make it suitable for high dose drugs.

In addition to liposomes, muco-adhesion can also be used to increase the residence time of particles in the lungs after administration (Fiegel et al., 2004). Lui et al. produced microparticles from hyaluronic acid (HA) which contained budesonide (BUD) nanocrystals in a ratio of 3.5:1 (HA:BUD). These microparticles showed a significantly longer pharmacological effect in rats compared to an inhaled budesonide suspension. The microcrystals had a half-life of 12.56 ± 8.39 h while the nanocrystals had a half-life of 0.98 ± 1.11 h. This longer half-life for the microcrystals was attributed to the muco-adhesive properties of hyaluronic acid (Liu et al., 2018). The avoidance of macrophages and the use of muco-adhesion is especially relevant for formulations with a delayed or controlled release profile, which may also be achieved by the use of excipients (Patel et al., 2015).

Finally, improving the dispersibility of inhalation powders is the most frequently mentioned argument in literature for drug particle (co-) engineering. Dispersibility of powders may be affected by weakening the cohesion forces between the particles. As such, any process parameter or excipient that modifies the particle surfaces (e.g. roughness, chemistry, hardness) in a favorable way may potentially improve powder dispersion. In some instances, the exact mechanism by which excipients improve dispersion is not clear. For example, co-milling of only 1% L-leucine with levodopa increased the levodopa fine particle fraction from the Cyclops dry powder inhaler at 4 kPa from 20 to 30% for the pure formulation to 60–70% for the blend (Luinstra et al., 2015). In contrast with co-spray dried L-leucine, co-milled L-leucine seems unlikely to affect the shape and surface chemistry of the levodopa particles in the formulation. In other examples much higher excipient masses are used and/or highly porous particles are produced to reduce the interparticulate forces and increase the efficacy of the dispersion

Table 2

Several APIs that have been formulated into liposomes in literature and their reported entrapment efficiency. References included: (Bai and Ahsan, 2009; Bhardwaj et al., 2012; Chougule et al., 2007; Shah and Misra, 2004).

API included in liposomes	Reported entrapment efficiency (%)
Amphotericin B	43.9 ± 2.4 to 95.8 ± 1.5
Tacrolimus	97 ± 0.4 to 98 ± 1.4
Rifampicin	43.08 ± 4.6
Isoniazid	18 ± 1 to 39.67 ± 1.5
Pyrazinamide	39.33 ± 8.1
Low molecular weight heparin	41

forces. Highly porous particles have relatively large geometric diameters and aerodynamic (e.g. drag) forces can get much better hold of such particles. Besides, such particles can escape macrophage clearance (Edwards et al., 1997) and when the porosity is partly external on the particle surface, they also have reduced contact points with surrounding particles. A very successful example in this respect are the PulmoSphere™ powders (Dellamary et al., 2000; Geller et al., 2011). However highly porous particles increase the total powder volume to be administered in a similar way as large excipient amounts increase the total powder mass. Therefore, designing and developing more powerful DPIs seems a better solution for improving dispersion.

Lastly, multi-step processes and excipients used in particle engineering may result in expensive formulations whereas some processes seem hardly efficient. For example, in liposome production encapsulation efficiency can be rather low for some APIs, as Table 2 illustrates. All these formulation aspects limit the usefulness of these formulations in practice for high dosed drugs. The use of excipients may also introduce certain health risks. Even for endogenous compounds that are 'generally regarded as safe' it may not always be clear what their effect with prolonged pulmonary administration (as with TB treatment) will be. Disturbing the physiological concentration of such substances in the long term may also disturb the processes in which they play a role.

6. DPI design for high powder doses

In the previous sections some differences in properties and behavior between adhesive mixtures for low dose drugs and high dose cohesive powder masses have been explained. They provide the basis for the design of DPIs for the pulmonary delivery of high powder doses. It has also been explained why using excipients in formulations for high dose drugs should preferably be avoided, particularly when they substantially increase the inhaled powder quantity and, by that, the number of inhalations needed to administer a single dose. Refraining from the use of such dispersion enhancing excipients may result in rather cohesive powders, but this may not be a problem when more effective dry powder dispersion principles for such formulations are designed and developed. Only to achieve special therapeutic effects or to improve the stability of the formulation, co-formulation with excipients may be inevitable.

Fig. 2 shows the basic design of a DPI. It consists of at least three primary functional parts, the powder formulation with the drug, a powder compartment to contain or measure the amount of formulation for a single drug dose and a dispersion principle for the powder formulation. In the Sections 2–5 the powder preparation and formulation techniques, as well as the most relevant properties of different powders were already discussed. From the discussions it may have become clear that various inhaler parts have to be compatible with the properties of the drug formulation. This is the reason why separate development of formulation and device is unlikely to yield a fully optimized combination.

From the viewpoint of consistency of delivered dose, the dose (measuring) compartment for high cohesive powder doses is of utmost importance. Several DPIs for delivery of adhesive mixtures have large

powder compartments with various volumetric measuring principles for the isolation of single doses from the bulk supply (Fig. 3A). The metering principle has to be operated by the patient and the inhaler has to be kept in the correct position for gravimetric filling of the measuring compartment, which is generally a cavity in a slide or a cylinder adjacent to the large powder compartment. This requires good flow properties of the formulation. However, pure micronized powders are rarely well flowing.

Agglomerates (spherical pellets) can be prepared to solve this problem but they are physically instable as they need to be soft to enable effective dispersion during inhalation. Storing them in large containers bears the risk that they will break or clump together when the DPI is exposed to vibration or shaking (as for instance during running) or dropping (Hoppentocht et al., 2014a). This risk increases with increasing powder mass and volume of the storage container. Pre-loaded compartments for single doses are a better solution for high dose micronized powders. Pelletization may be necessary to fill such compartments accurately and reproducibly, but once in the compartment any break down or lumping together of the pellets will no longer affect the dose measuring and consistency of delivered dose. Single dose compartments are also used for adhesive mixtures in capsule and blister inhalers but these types of dose containers may not be the best choice for high doses of cohesive powders. Capsules generally need high flow rates for complete discharge of their contents through the narrow holes and/or slits obtained from perforating their ends in the relatively short time of inhalation. Besides, both hard gelatin and hydroxypropyl methylcellulose (HPMC) capsules frequently fragment in the violent air stream, thereby releasing inhalable fragments. Single dose cartridges (SDC) seem a better solution because they potentially provide better protection of the drug formulation against moisture uptake and do not fragment during inhalation. Peelable lidding foils will be needed for cohesive high dose powder masses to uncover the entire SDC surface because piercing will create small shreds of lidding foil that stick beyond the surface around the discharge hole (Fig. 3B). These shreds will press the particles sideward and become an obstacle in the exit route for the cohesive powder. Completely opened SDCs have another major advantage. They enable to direct the air stream through the SDC via separate inlet and exit channels (Fig. 3C). This improves the efficacy of the entrainment of cohesive powder agglomerates and also shortens the discharge time.

The dispersion principle is the engine of the inhaler that converts the cohesive powder mass into an appropriate aerosol for inhalation. It derives external forces from the fluid energy to overcome the inter-particulate attraction forces in the powder during inhalation. The disperser has to be designed to fulfill the basic requirements for effective aerosol deposition in the human respiratory tract, which have been described extensively elsewhere (Demoly et al., 2014). These requirements are basically the same for low and high dose DPIs but they may depend on the type of therapy and hence, the preferred site of deposition for the aerosol particles. They may also be different for different patient groups (Lexmond et al., 2017). The basic requirements for effective aerosol deposition are briefly summarized in Table 3. Particularly prerequisite 3 in Table 3 has long been misinterpreted. A higher fine particle fraction, and/or a finer aerosol at a higher flow rate are needed to compensate (at least partly) for the shift in deposition towards larger airways, including the mouth-throat region (Demoly et al., 2014). This more or less excludes the use of battery or pressurized air powered dispersion which is independent of the inhalation maneuver. Auxiliary energy sources for dispersion have previously been applied for instance in the Spiros and Exubera DPIs (Harper et al., 2007; Licalsi et al., 1999). Such complex inhalers are also unwanted because of the cost aspect. To achieve the prerequisites in Table 3, different dispersion principles may be optimal for different powder formulations. Air classifier technology has previously been presented as the most effective technology for dispersion of adhesive mixtures (De Boer et al., 2003). Air classifiers and other circulation chambers generate inertial

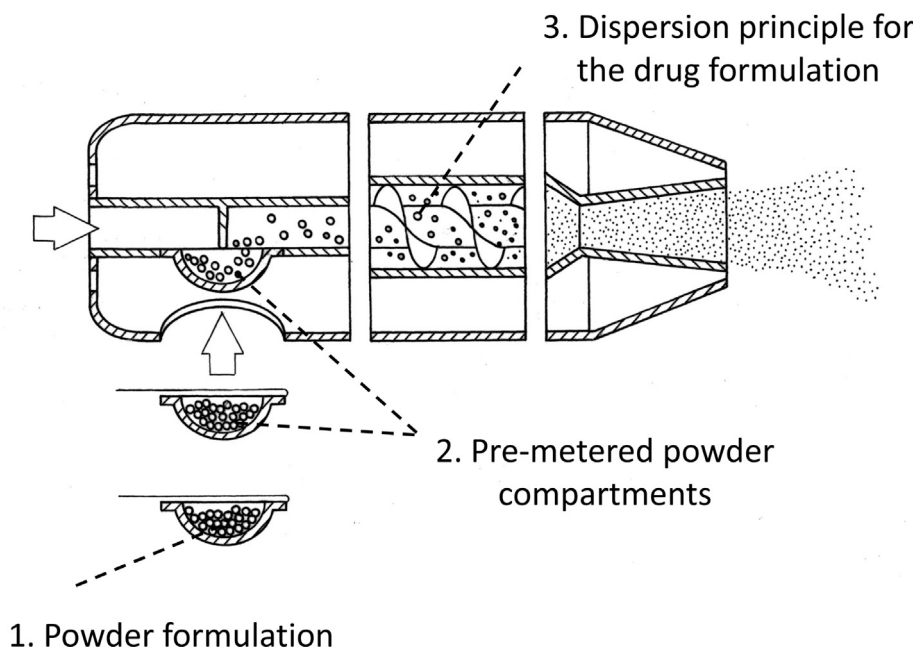

Fig. 2. Schematic representation of a high dose dry powder inhaler. Shown are the functional parts of which the powder formulation, dose (measuring) compartment and dispersion principle need to be a compatible combination.

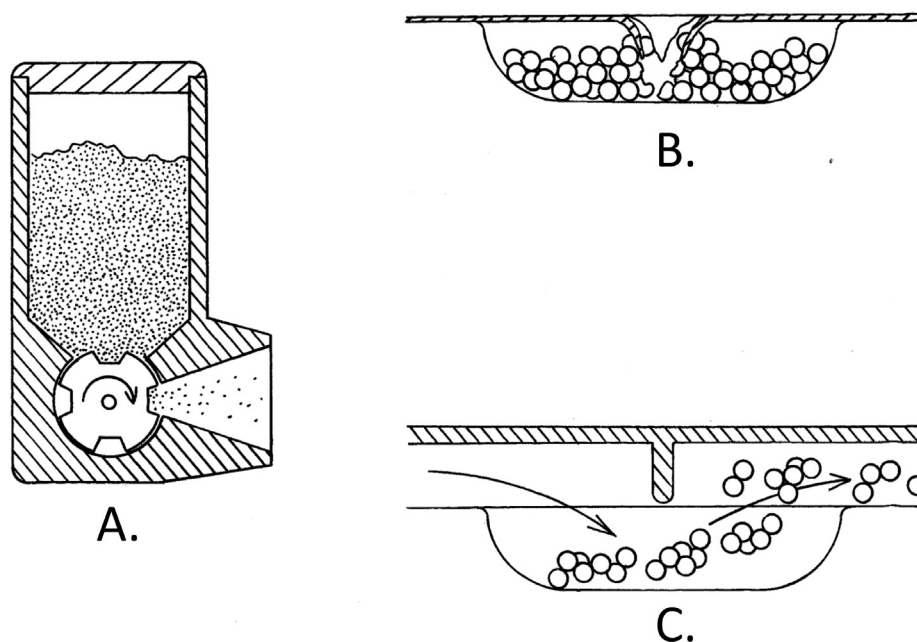

Fig. 3. (A) Powder container with dose measuring cylinder for powders with sufficient flow properties to enable volumetric filling by the force of gravity. (B) Pre-measured blister with pierced lidding foil, showing the patches of foil that protrude into the dose cavity around the discharge hole and hinder the powder to be entrained by the inhaled air stream. The risk of incomplete blister emptying becomes greater with deteriorating flow properties of the powder. (C) Blister with peelable lidding foil. Opening the entire blister surface provides the possibility to conduct (at least part of) the air stream through the blister for improved powder entrainment.

Table 3
General prerequisites for effective aerosol delivery to the human respiratory tract with dry powder inhalers (the same for high and low doses).

1. aerosol delivery at a low inhaled flow rate, preferably in the range between 30 and 50 L/min, to avoid high oropharyngeal deposition
2. delivery of the fast majority of the aerosol mass in the first 0.5–1.5 L of inhaled air (V_{IN}). The exact volume of V_{IN} varies with the patient population and depends on their vital capacity
3. delivery of a higher fine particle mass and/or a higher fineness of the aerosol at a higher flow rate to compensate (at least partly) for the shift in deposition towards larger airways, including the oropharynx
4. delivery of an aerosol within the preferred aerodynamic size range of 1–3 μm^*

* Inhalation aerosols should not be defined with their mass median aerodynamic diameter (MMAD) as this gives no information about the mass fraction of the dose within the preferred size range.

separation forces which are proportional to the third power of the particle diameter. In comparison, drag and lift forces, as in turbulent air streams, are proportional to the first power of the particle diameter (in the Stokes' regime). Because of their good flow and aerosolization properties, carrier-based formulations are mostly equally distributed over the entire circulation chamber for the powder in an air classifier-based dispersion principle. This is different for cohesive powders. They mostly enter circulation chambers as a lump of powder from the dose compartment. This can disturb the flow symmetry in that chamber and thereby its dispersion efficacy. Moreover, cohesive powders are also adhesive and tend to stick to the chamber wall upon collision with that wall. As a result, thick powder layers may be formed and they reduce the emitted dose considerably. Retention within the circulation chamber can to reasonable extent be controlled by adding so-called sweeper crystals to the micronized powder (de Boer et al., 2006). Such

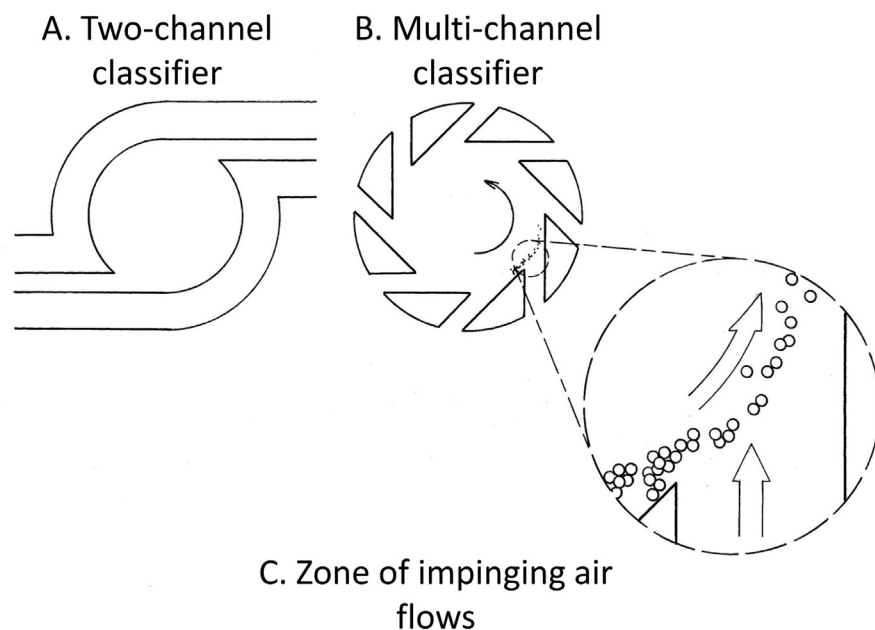

Fig. 4. Different designs of an air classifier as dispersion principle for inhalation powders. (A) Basic concept of a disk-shaped circulation chamber with two opposite air supply channels designed for the dispersion of (low dose) adhesive mixtures primarily. Freely, non-sticking carrier particles circulate along the circumference of the chamber and collide with its cylindrical wall and with each other generating inertial forces for the detachment of drug particles from the carrier surface. (B) Classifier with a multitude of bypass channels for the dispersion of cohesive (sticky) powders. In the area in front of a bypass channel the impinging air flows create internal shear in agglomerates, which results in disruption of the agglomerates (C). The air stream from the bypass channel also keeps primary drug particles away from the remainder of the cylindrical chamber wall.

crystals can be lactose crystals, similar to the carrier crystals in adhesive mixtures. They circulate in the chamber and wipe adhering drug particles from the cylindrical chamber walls during inhalation. Usually they are larger than the theoretical cutoff value of the classifier chamber as a result of which they are not inhaled by the patient. Another approach to tackle this problem of high classifier retention is to interrupt its cylindrical wall with a number of tangential bypass channels (Fig. 4A). Such channels support the circular flow in the chamber and increase the contribution of the mechanism of shear flow to the powder dispersion (Fig. 4B).

One limitation of air classifiers is their limited volume. Their design is aimed at finding the optimal dispersion efficacy for the powder mass to be administered. This generally includes the smallest possible circulation chamber for that powder mass yielding the highest air (and particle) velocity inside the chamber and, thus, the highest separation forces. A larger chamber can contain a larger powder mass but has a lower dispersion efficacy. This is due to a much lower air velocity at the same flow rate, which preferably should not exceed 30–50 L/min (Table 3). A smaller chamber for the same powder mass results in overloading: particles will crowd each other out by uncontrolled collisions, even if they are still much larger than the theoretical cutoff value. A solution for this problem can be a gradual feeding of the classifier from the dose compartment in order to find a good equilibrium between classifier feed and discharge rate. This will result in a fairly constant classifier load. Finding a good balance between feed and discharge rate may be difficult however, and it may depend on the type of formulation. Dispersion of cohesive powders can follow different regimens, requiring different time spans. Particularly when the dispersion rate is initially high, high mass fractions of fine particles are generated and the particles can leave the classifier instantaneously when their diameter is smaller than the cut-off diameter of the classifier. According to this regimen, discharge time can be very short. Dispersion may also be a more staggered process and large agglomerates may stepwise break into smaller particles. This takes more time to discharge the total dose and the feed rate of the classifier must be lower. This example emphasizes the need for joint design and development of formulation and device as it shows how difficult fine tuning can be for achieving the best possible performance of the combination.

An optimum classifier feed rate exists also in another respect. If the feed rate to the disperser principle is too low not all powder will be delivered to the patient or be transported to the lower airways in the total inhalation time. For this to happen the powder generally has to be

dispersed in the first 1.5 L of air (Table 3) (Hoppentocht et al., 2014a). For specific patient groups such as children this may even be within the first 0.5 L of air (Lexmond et al., 2017). A similar problem may arise in classic capsule inhalers. Whereas a capsule can contain 150 mg of powder, it is difficult to disperse this or even a fraction of this amount of powder during one inhalation. Thus, it often requires multiple inhalation maneuvers to empty the capsule (Hoppentocht et al., 2014a). The need for multiple inhalation maneuvers reduces the motivation of patients to follow the inhalation instruction and to adhere to the therapy. Therefore, the number of inhalations required should be minimized. Especially for the delivery of antibiotics adherence and compliance are two major challenges. As Newman et al. showed, poor inhaler use can result in poor adherence and even more serious, treatment failure (Newman and Busse, 2002).

Aerodynamic dispersion principles may be appropriate for the dispersion of large cohesive powder doses too. They find wide application in the dispersion of powders for particle size analysis and various industrial processes. They rely mainly on rapid acceleration or deceleration of particle agglomerates, shear flow, particle-particle collisions, or a combination of these mechanisms. Examples are eductors, venturis, nozzles and capillary tubes (Calvert et al., 2009). Standard versions of these principles are normally operated at high flow rates, requiring much higher pressure drops (in the range of several bars) than patients can generate. Therefore, special designs are needed to serve adequately as disperser for high powder doses meant for inhalation. They are an interesting option however, as they are relatively simple and exploring the possibilities with such principles seems worthwhile.

Several additional inhaler aspects or requirements may be the same for inhalers that contain adhesive mixtures or large cohesive powder masses and yet be much more meaningful or necessary for high cohesive powder doses. For instance, in the treatment of infectious diseases the minimum inhibitory concentration (MIC) of the inhaled antibiotic needs to be achieved at all places where the pathogenic bacteria are present. At places where the antibiotic concentration remains consistently below the MIC-value, resistance development of the bacteria against the antibiotic may occur. From currently marketed dry powder inhalers approximately one third of the inhaled aerosol is deposited in the upper airways, one third in the central and one third in the respiratory airways. Considering the exponential increase in lung volume and surface area from the lobar bronchi towards the alveoli, this may result in an extreme decrease in drug concentration by a factor 100 or more over the entire respiratory tract (Demoly et al., 2014). A

significant improvement in peripheral deposition at the cost of central and upper tract deposition does not even change the decrease in concentration much. This bears the risk of serious underdosing of the lowest airways and for this reason the aerodynamic size distribution of the delivered aerosol and the inspiratory flow maneuver with which the aerosol is inhaled are of utmost importance. Many high dose drugs are also considerably more hygroscopic than low dose drugs against asthma and COPD. Antibiotics like tobramycin sulfate can absorb sufficient water from the air at a high relative humidity (above approx. 65%) to dissolve completely and merge from particles into droplets (Hoppentocht et al., 2015). Also, amorphous sugars used to stabilize large biopharmaceutical molecules in the dry state are extremely hygroscopic. This requires not only good moisture protection of the powder formulation in the dose compartment but also advocates the use of disposable inhalers for such drugs. Small drug residues in dry powder inhalers after use are inevitable and when such inhalers are exposed to the ambient air, liquefying of the residual particles may make following inhalations with the same device impossible. Because of the high drug doses involved the number of residual particles will be rather extreme. Even for a relatively low retention of 5%, the drug mass retained from a single 50 mg dose is 2.5 mg. This amount of drug is sufficient to form relatively large droplets upon water sorption in the passageways for the powder. Therefore, from the viewpoint of efficacy and safety, hygroscopic cohesive powders should preferably be administered with disposable devices.

Other high powder dose applications that could benefit from a disposable inhaler are all one time use medications, such as vaccinations and rescue medication, or the short-term treatment of infections in hospitals (de Boer and Hagedoorn, 2015; Friebel and Steckel, 2010). Although disposable inhalers can be more expensive than reusable ones, they are not necessarily increasing the cost of the therapy, because a more effective treatment can save much higher costs in the long term, e.g. those from hospitalization.

One aspect of consideration for the use of disposable medical devices is the environmental burden. For the inhalation of antibiotics, which are currently mostly nebulized, the choice is either between a disposable plastic DPI or two disposable (plastic or glass) vials for the drug and sterile water respectively, plus a syringe with needle, or a special dispensing pin. In either case, it has to be recommended that used devices and materials polluted with drug residues or containing needles, are collected and transferred to a special recycling depot. Many DPIs are made of a medical grade of polycarbonate, which is difficult to reuse and received recycling code 7 for that. However, the inhaler can be made of plastic only, whereas for nebulization different waste materials are produced which makes recycling even more complex and expensive. Besides, recent research has improved the possibilities for recycling of polycarbonate waste material considerably (Datta and Kopczyńska, 2016).

Another consideration of interest for disposable inhalers is the cost of the therapy. Although they can be more expensive than re-usable ones, it is often the price of the API that determines the cost of the drug-device combination. Besides, disposable inhalers can be very simple (Fig. 5A and B) and yet highly effective (next section) if designed appropriately. Their use can eliminate several risks, such as improper functioning due to liquefying of drug residues after moisture uptake, patient cross-contamination, etc. (de Boer and Hagedoorn, 2015).

7. Currently available high dose DPIs

High dose inhalers described in literature are the Podhaler®, the Turbospin®, the Orbital®, the FB-DPI, the Twincer® and the Cyclops®. They are depicted in Fig. 5. Other high dose inhalers with little to no published information about their performance are the Powdair, the ICOone™ and the Twincaps®, which for that reason will not be discussed further.

The Podhaler® (T-326, Fig. 2A) is the original Turbospin® capsule

inhaler and used for the TOBI® Podhaler® product from Novartis AG. It is used with the previously mentioned highly dispersible engineered particles using the PulmoSphere™ technology, with a capsule containing 28 mg of the drug tobramycin. The capsule with approx. 55 mg of powder (including excipients) is emptied in a single inhalation maneuver. However, in practice patients are instructed to perform a second inhalation maneuver to ensure sufficient emptying. Total dose is 4 capsules, or 112 mg of tobramycin. The capsule load of 28 mg tobramycin was based on the ability of 6–10 year old patients to empty the capsule, and a higher load is likely achievable in adults (Geller et al., 2011). In this product the formulation is adapted to the inhaler, and it is likely that a more efficient and better accepted product is possible when the inhaler is adapted to tobramycin, with a stronger dispersion system lowering the need for excipients. Furthermore, the dose system could be more efficient when a prefilled compartment is used instead of a capsule. This would likely lower the amount of inhalation maneuvers needed and increase the compliance and adherence to therapy.

A smaller version of the Turbospin® capsule inhaler is used in the Colobreathe® product (Fig. 2B). Its capsules contain approximately 145 mg of colistimethate sodium without excipients, of which 125 mg is emitted. A dose comprises a single capsule (Schuster et al., 2013). Patients have to repeat inhalation maneuvers until the capsule is empty (European Medicines Agency, 2018). This device would benefit from the same improvements as the Podhaler®, i.e. a dose compartment instead of a capsule and a more powerful dispersion principle.

The Orbital® (Fig. 2C) dry powder inhaler is an inhaler currently under development by Pharmaxis Ltd. It is able to dose 50 mg to several hundreds of milligrams by multiple inhalation maneuvers (Young et al., 2013; Zhu et al., 2015). It is a disposable DPI and the dose is kept in a single dosing puck. The dose delivered during each individual inhalation is a result of the airflow through the device and the geometry of the dose compartment and that of the puck itself. They demonstrated the ability to dose 400 mg of mannitol in a single inhaler, but with multiple inhalations (Zhu et al., 2015). Discharge and dispersion is a result of the rotation of the puck. The device is disposable and comes with a prefilled dose compartment, which makes it suitable for the delivery of high doses. However, the need for repeated inhalation maneuvers could lower the compliance and adherence to therapy.

The FB-DPI (Fig. 2D), described by Farkas et al. is based on the fluid bed principle for dispersion. In the inhaler small spheres are placed that have a fluid-like behavior during inhalation. This random motion of the small spheres causes turbulence and collisions, which will disperse powder as it passes through it. They reported that they were able to disperse 100 mg of powder efficiently from the inhaler and the formulation they used contained 20% leucine, which is known to aid dispersion. Furthermore, they reported that the removal of the small spheres did not have a negative effect on the fine particle fraction while increasing the emitted dose (Farkas et al., 2015). As a result, questions can be raised on the efficacy of the dispersion principle used. The device does use a prefilled dose compartment instead of a capsule. However, it is unclear how well the dose compartment protects the formulation from moisture, what the maximum dispersible dose is and how many inhalations are required to administer this dose.

The Twincer® (Fig. 2E) and Cyclops® (Fig. 2F) are both disposable devices developed at the University of Groningen (de Boer et al., 2006; Hoppentocht et al., 2015). Both use the air classifier technology for dispersion, which is based on inertial forces. Optimized for different formulations, the Twincer® is currently prescribed on the bases of medical necessity in cystic fibrosis patients for the delivery of 55 mg of milled colistimethate sodium, without the need for excipients (Hagedoorn et al., 2017). The Cyclops® device is optimized for the delivery of pure tobramycin, and is able to dose up to at least 50 mg is one single inhalation maneuver with a fine particle fraction of > 90% of the delivered dose (Hoppentocht et al., 2015). With the minimal use of excipients (2% L-leucine) also levodopa, with a dose up to 40 mg, has

A: Podhaler®**B: Turbospin®****C: Orbital®****D: FB-DPI****E: Twincer®****F: Cyclops®**

Fig. 5. An overview of the six DPIs capable of high dosing described in literature. A shows the Podhaler® by Novartis AG, B the Colobreathe®, C the FB-DPI by the Virginia Commonwealth University, D the Orbital® by Pharmaxis Ltd, E the Twincer®, and F the Cyclops®, both from the University of Groningen.

been successfully formulated for this device (Luinstra et al., 2015). Both devices use a pre-filled dose compartment and are able to administer the dose in one inhalation maneuver.

8. Conclusions

In this review we have defined high powder doses for pulmonary administration as all powders that contain more than 2.5 mg of active inhalable microparticles with or without excipient. Following this definition, drugs with a low potency such as antibiotics and drugs with a high potency that need a substantial fraction of excipient(s), such as vaccines stabilized in sugar glasses, are all considered 'high dose drugs'. For high dose drugs one cannot rely on adhesive mixtures to solve many of the challenges brought about by the high co- and adhesiveness associated with the micronized state of the particles. For many low potency drugs one can neither rely on large fractions of excipient to overcome these challenges, as they would increase the powder mass or volumes to be administered to amounts that either require too many inhalation maneuvers when splitting them up, or are intolerable to the patient when taken at once. Therefore, we strongly advocate an approach in which high dose DPIs and their formulations are developed in unison in order to adapt the DPI design and performance to the properties of the drug formulation. Techniques such as spray drying and supercritical fluid drying enable considerable rational particle engineering with little to no excipients. For that reason, they should be the starting point of any formulation endeavors when more complex and elaborate formulations are not required from a therapeutic perspective. We envisage that the most optimal dry powder inhaler to disperse high

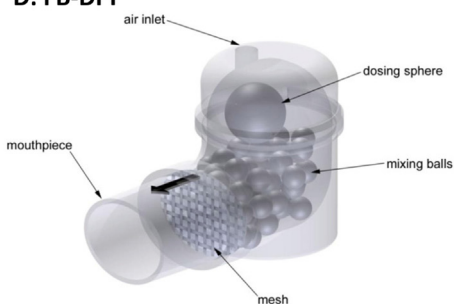
dose formulations contains a pre-loaded dose container with a peelable lidding foil, is disposable and cheap, intuitive in use and contains an effective dispersion principle. Effective dispersion of high dose powders may not always be achieved with dispersion principles relying on what are generally considered the most effective (i.e. inertial) dispersion forces. High dose powders are often highly compactable and relying on collisions with the inhaler walls for dispersion may, therefore, result in considerable retention of the formulation within the inhaler. Great opportunities to make a difference with the pulmonary administration of high powder doses are awaiting to be explored. We strongly believe that the knowledge required for the successful development of high dose dry powder inhalation products is readily available. Therefore, it is only a matter of taking the right approach to make these great opportunities into great successes.

Conflict of interest

This research did not receive any specific grant from funding agencies in the public, commercial, or not-for-profit sectors.

The employer of IS, FG, AHdB, PH and HWF receives royalties from AstraZeneca.

FG is part-time employed by PureIMS B.V., manufacturer of the Twincer and Cyclops DPIs.

Author contributions: IS, AHdB and FG wrote the draft; IS, FG, PH, HWF and AHdB critically revised the draft.

References

- Agrawal, P., 2015. Biopharmaceuticals: an emerging trend in drug development. *SOJ Pharm. Pharm. Sci.* 2, 1–2. <http://dx.doi.org/10.1038/nbt0708-743.4>.
- Ahmed, T., Gonzalez, B.J., Danta, L., 1999. Prevention of exercise-induced bronchoconstriction by inhaled low-molecular-weight heparin. *Am. J. Respir. Crit. Care Med.* 160, 576–581. <http://dx.doi.org/10.1164/ajrccm.160.2.9812076>.
- Andersen, C.U., Sønderskov, L.D., Bendstrup, E., Voldby, N., Cass, L., Ayrton, J., Hilberg, O., 2017. Voriconazole concentrations in plasma and epithelial lining fluid after inhalation and oral treatment. *Basic Clin. Pharmacol. Toxicol.* 121, 430–434. <http://dx.doi.org/10.1111/bcpt.12820>.
- Arora, S., Haghi, M., Loo, C.Y., Traini, D., Young, P.M., Jain, S., 2015. Development of an inhaled controlled release voriconazole dry powder formulation for the treatment of respiratory fungal infection. *Mol. Pharm.* 12, 2001–2009. <http://dx.doi.org/10.1021/mp500808t>.
- Audouy, S.A.L., van der Schaaf, G., Hinrichs, W.L.J., Frijlink, H.W., Wilschut, J., Huckriede, A., 2011. Development of a dried influenza whole inactivated virus vaccine for pulmonary immunization. *Vaccine* 29, 4345–4352. <http://dx.doi.org/10.1016/j.vaccine.2011.04.029>.
- Bai, S., Ahsan, F., 2009. Synthesis and evaluation of pegylated dendrimeric nanocarrier for pulmonary delivery of low molecular weight heparin. *Pharm. Res.* 26, 539–548. <http://dx.doi.org/10.1007/s11095-008-9769-y>.
- Barnett, A.H., 2004. Exubera inhaled insulin: a review. *Int. J. Clin. Pract.* 58, 394–401. <http://dx.doi.org/10.1111/j.1368-5031.2004.00178.x>.
- Bhardwaj, A., Kumar, L., Narang, R.K., Murthy, R.S.R., 2012. Development and characterization of ligand-appended liposomes for multiple drug therapy for pulmonary tuberculosis. *Artif. Cells. Blood Substitutes Immobilization Biotechnol.* 142001, 1–8. <http://dx.doi.org/10.3109/10731199.2012.702316>.
- Calvert, G., Ghadiri, M., Tweedie, R., 2009. Aerodynamic dispersion of cohesive powders: a review of understanding and technology. *Adv. Powder Technol.* 20, 4–16. <https://doi.org/https://doi.org/10.1016/j.apt.2008.09.001>.
- Carpenter, J.F., Sellers, S.P., Sievers, R.E., 2002. Supercritical Fluid-assisted Nebulization and Bubble Drying.
- Castellanos, A., 2005. The relationship between attractive interparticle forces and bulk behaviour in dry and uncharged fine powders. *Adv. Phys.* <http://dx.doi.org/10.1080/17461390500402657>.
- Chougule, M., Padhi, B., Misra, A., 2007. Nano-liposomal dry powder inhaler of tacrolimus: preparation, characterization, and pulmonary pharmacokinetics. *Int. J. Nanomed.* 2, 675–688.
- Corcoran, T.E., Niven, R., Verret, W., Dilly, S., Johnson, B.A., 2014. Lung deposition and pharmacokinetics of nebulized cyclosporine in lung transplant patients. *J. Aerosol Med. Pulm. Drug Deliv.* 27, 178–184. <http://dx.doi.org/10.1089/jamp.2013.1042>.
- Cun, D., Wan, F., Yang, M., 2015. Formulation strategies and particle engineering technologies for pulmonary delivery of biopharmaceuticals. *Curr. Pharm. Des.* 21, 2599–2610. <http://dx.doi.org/10.2174/1381612821666150416100800>.
- Datta, J., Koczyńska, P., 2016. From polymer waste to potential main industrial products: actual state of recycling and recovering. *Crit. Rev. Environ. Sci. Technol.* 46, 905–946. <http://dx.doi.org/10.1080/10643389.2016.1180227>.
- Davis, K.K., Kao, P.N., Jacobs, S.S., Ruoss, S.J., 2007. Aerosolized amikacin for treatment of pulmonary Mycobacterium avium infections: an observational case series. *BMC Pulm. Med.* 7, 2. <http://dx.doi.org/10.1186/1471-2466-7-2>.
- de Boer, A.H., Chan, H.K., Price, R., 2012. A critical view on lactose-based drug formulation and device studies for dry powder inhalation: which are relevant and what interactions to expect? *Adv. Drug Deliv. Rev.* 64, 257–274. <http://dx.doi.org/10.1016/j.addr.2011.04.004>.
- de Boer, A.H., Hagedoorn, P., 2015. The role of disposable inhalers in pulmonary drug delivery. *Expert Opin. Drug Deliv.* 12, 143–157. <http://dx.doi.org/10.1517/17425247.2014.952626>.
- De Boer, A.H., Hagedoorn, P., Gjaltema, D., Goede, J., Frijlink, H.W., 2003. Air classifier technology (ACT) in dry powder inhalation: Part 1. Introduction of a novel force distribution concept (FDC) explaining the performance of a basic air classifier on adhesive mixtures. *Int. J. Pharm.* 260, 187–200. [http://dx.doi.org/10.1016/S0378-5173\(03\)00250-3](http://dx.doi.org/10.1016/S0378-5173(03)00250-3).
- de Boer, A.H., Hagedoorn, P., Westerman, E.M., Le Brun, P.P.H., Heijerman, H.G.M., Frijlink, H.W., 2006. Design and in vitro performance testing of multiple air classifier technology in a new disposable inhaler concept (Twincer??) for high powder doses. *Eur. J. Pharm. Sci.* 28, 171–178. <http://dx.doi.org/10.1016/j.ejps.2005.11.013>.
- Dellamary, L.A., Tarara, T.E., Smith, D.J., Woelk, C.H., Adractus, A., Costello, M.L., Gill, H., Weers, J.G., 2000. Hollow porous particles in metered dose inhalers. *Pharm. Res.* 17, 168–174. <http://dx.doi.org/10.1023/A:1007513213292>.
- Demoly, P., Hagedoorn, P., de Boer, A.H., Frijlink, H.W., 2014. The clinical relevance of dry powder inhaler performance for drug delivery. *Respir. Med.* 108, 1195–1203. <https://doi.org/https://doi.org/10.1016/j.rmed.2014.05.009>.
- Dillow, A.K., Dehghani, F., Hrkach, J.S., Foster, N.R., Langer, R., 1999. Bacterial inactivation by using near- and supercritical carbon dioxide. *Proc. Natl. Acad. Sci.* 96, 10344–10348. <http://dx.doi.org/10.1073/pnas.96.18.10344>.
- Edwards, D.A., Hanes, J., Caponetti, G., Hrkach, J., Ben-Jebria, A., Eskew, M. Lou, Mintzes, J., Deaver, D., Lotan, N., Langer, R., 1997. Large porous particles for pulmonary drug delivery. *Science* 276, 1868–1872.
- Ehrmann, S., Mercier, E., Vecellio, L., Ternant, D., Paintaud, G., Dequin, P.F., 2008. Pharmacokinetics of high-dose nebulized amikacin in mechanically ventilated healthy subjects. *Intensive Care Med.* 34, 755–762. <http://dx.doi.org/10.1007/s00134-007-0935-1>.
- Eldon, M., Corkery, K., Gribben, D., Fink, J., Niederman, M., 2008. NKTR-061 (inhaled amikacin) delivers high lung doses in mechanically ventilated patients with pneumonia and in healthy subjects. *Crit. Care* 12, P1. <http://dx.doi.org/10.1186/cc6222>.
- European Medicines Agency, 2018. Colobreathe (colistimethate sodium): EU summary of product characteristics. [WWW Document], n.d. URL http://www.ema.europa.eu/docs/en_GB/document_library/EPAR_-_Product_Information/human/001225/WC500123690.pdf (accessed 2.13.18).
- Farkas, D.R., Hindle, M., Longest, P.W., Engineering, N., 2015. Characterization of a New High-Dose Dry Powder Inhaler (DPI) Based on a Fluidized Bed Design 43, 2804–2815. <https://doi.org/10.1007/s10439-015-1335-2.Characterization>.
- Feeley, J.C., York, P., Sumbly, B.S., Dicks, H., 1998. Determination of surface properties and flow characteristics of salbutamol sulphate, before and after micronisation. *Int. J. Pharm.* 172, 89–96. [http://dx.doi.org/10.1016/S0378-5173\(98\)00179-3](http://dx.doi.org/10.1016/S0378-5173(98)00179-3).
- Fiegel, J., Fu, J., Hanes, J., 2004. Poly(ether-anhydride) dry powder aerosols for sustained drug delivery in the lungs. *J. Control. Release* 96, 411–423. <http://dx.doi.org/10.1016/j.jconrel.2004.02.018>.
- Friebel, C., Steckel, H., 2010. Single-use disposable dry powder inhalers for pulmonary drug delivery. *Expert Opin. Drug Deliv.* 7, 1359–1372. <http://dx.doi.org/10.1517/17425247.2010.538379>.
- Geller, D.E., Weers, J., Heuerding, S., 2011. Development of an inhaled dry-powder formulation of tobramycin using PulmoSphere™ technology. *J. Aerosol Med. Pulm. Drug Deliv.* 24, 175–182. <http://dx.doi.org/10.1089/jamp.2010.0855>.
- Ghanbarzadeh, S., Saeeneya, Y., Valizadeh, H., Nokhodchi, A., Hamishehkar, H., 2016. Carrier free dry powder formulation of sildenafil for potential application in pulmonary arterial hypertension. *Pharmazie* 71, 181–184. <http://dx.doi.org/10.1691/ph.2016.5144>.
- Grasmeijer, F., Hagedoorn, P., de Boer, A.H., 2017. Re-designing the colistimethate sodium Twincer® for large-scale production, in: Drug Delivery to the Lungs Conference.
- Grasmeijer, F., Hagedoorn, P., Frijlink, H.W., de Boer, A.H., 2013. Drug content effects on the dispersion performance of adhesive mixtures for inhalation. *PLoS One* 8, e71339.
- Grasmeijer, F., Grasmeijer, N., Hagedoorn, P., Frijlink, H.W., Boer, A., H. de, 2015. Recent advances in the fundamental understanding of adhesive mixtures for inhalation. *Curr. Pharm. Des.* <http://dx.doi.org/10.2174/1381612821666151008124622>.
- Groves, S., Galazka, M., Johnson, B., Corcoran, T., Verceles, A., Britt, E., Todd, N., Griffith, B., Smaldone, G.C., Iacono, A., 2010. Inhaled cyclosporine and pulmonary function in lung transplant recipients. *J. Aerosol Med. Pulm. Drug Deliv.* 23, 31–39. <http://dx.doi.org/10.1089/jamp.2009.0748>.
- Hagedoorn, P., Grasmeijer, F., Hoppentocht, M., Akkerman, O.W., Frijlink, H.W., de Boer, A.H., 2017. In vitro evaluation of the PurelMS Twincer® colistin dry powder inhaler as a non-cough-inducing alternative to Forest's Colobreathe®, In: ERS International Congress.
- Harper, N.J., Gray, S., Groot, J. De, Parker, J.M., Sadrzadeh, N., Schuler, C., Schumacher, J.D., Seshadri, S., Smith, A.E., Steeno, G.S., Stevenson, C.L., Tanieri, R., Wang, M., Bennett, D.B., System, Pulmonary Insulin Delivery, 2007. The design and performance of the Exubera®. *Diabetes Technol. Ther.* 9, S-16-S-27. <http://dx.doi.org/10.1089/dia.2007.0222>.
- Hayes, D., Zwischenberger, J.B., Mansour, H.M., 2010. Aerosolized tacrolimus: a case report in a lung transplant recipient. *Transplant. Proc.* 42, 3876–3879. <http://dx.doi.org/10.1016/j.transproceed.2010.08.029>.
- Heng, J.Y.Y., Thielmann, F., Williams, D.R., 2006. The effects of milling on the surface properties of form I paracetamol crystals. *Pharm. Res.* 23, 1918–1927. <http://dx.doi.org/10.1007/s11095-006-9042-1>.
- Hersey, J.A., 1975. Ordered mixing: A new concept in powder mixing practice. *Powder Technol.* 11, 41–44. [https://doi.org/https://doi.org/10.1016/0032-5910\(75\)80021-0](https://doi.org/https://doi.org/10.1016/0032-5910(75)80021-0).
- Hinrichs, W.L.J., Prinsen, M.G., Frijlink, H.W., 2001. Inulin glasses for the stabilization of therapeutic proteins. *Int. J. Pharm.* 215, 163–174. [http://dx.doi.org/10.1016/S0378-5173\(00\)00677-3](http://dx.doi.org/10.1016/S0378-5173(00)00677-3).
- Hoppentocht, M., Hagedoorn, P., Frijlink, H.W., de Boer, A.H., 2014a. Technological and practical challenges of dry powder inhalers and formulations. *Adv. Drug Deliv. Rev.* 75, 18–31. <http://dx.doi.org/10.1016/j.addr.2014.04.004>.
- Hoppentocht, M., Hagedoorn, P., Frijlink, H.W., de Boer, A.H., 2014b. Developments and strategies for inhaled antibiotic drugs in tuberculosis therapy: a critical evaluation. *Eur. J. Pharm. Biopharm.* 86, 23–30. <http://dx.doi.org/10.1016/j.ejpb.2013.10.019>.
- Hoppentocht, M., Akkerman, O.W., Hagedoorn, P., Frijlink, H.W., De Boer, A.H., 2015. The Cyclops for pulmonary delivery of aminoglycosides; a new member of the Twincer family. *Eur. J. Pharm. Biopharm.* 90, 8–15. <http://dx.doi.org/10.1016/j.ejpb.2015.01.012>.
- Keating, G.M., 2013. Loxapine inhalation powder: a review of its use in the acute treatment of agitation in patients with bipolar disorder or schizophrenia. *CNS Drugs* 27, 479–489. <http://dx.doi.org/10.1007/s40263-013-0075-9>.
- Khatri, L., Taylor, K.M.G., Craig, D.Q.M., Palin, K., 2001. An assessment of jet and ultrasonic nebulisers for the delivery of lactate dehydrogenase solutions. *Int. J. Pharm.* 227, 121–131. [https://doi.org/https://doi.org/10.1016/S0378-5173\(01\)00790-6](https://doi.org/https://doi.org/10.1016/S0378-5173(01)00790-6).
- Konstan, M.W., Flume, P.A., Kappler, M., Chiron, R., Higgins, M., Brockhaus, F., Zhang, J., Angyalosi, G., He, E., Geller, D.E., 2011. SAFETY, efficacy and convenience of tobramycin inhalation powder in cystic fibrosis patients: the eager trial 10, 54–61. <https://doi.org/10.1016/j.jcf.2010.10.003.SAFETY>.
- Labiris, N.R., Dolovich, M.B., 2003. Pulmonary drug delivery. Part I: physiological factors affecting therapeutic effectiveness of aerosolized medications. *Br. J. Clin. Pharmacol.* 56, 588–599. <http://dx.doi.org/10.1046/j.1365-2125.2003.01892.x>.
- LeWitt, P.A., Hauser, R.A., Grosset, D.G., Stocchi, F., Saint-Hilaire, M.H., Ellenbogen, A., Leononen, M., Hampson, N.B., DeFeo-Fraulini, T., Freed, M.I., Kiebertz, K.D., 2016. A randomized trial of inhaled levodopa (CVT-301) for motor fluctuations in Parkinson's disease. *Mov. Disord.* 31, 1356–1365. <http://dx.doi.org/10.1002/mds.26611>.
- Lexmond, A.J., Hagedoorn, P., Frijlink, H.W., Rottier, B.L., de Boer, A.H., 2017. Prerequisites for a dry powder inhaler for children with cystic fibrosis. *PLoS One* 12,

- e0183130.
- Li, L., Sun, S., Parumasivam, T., Denman, J.A., Gengenbach, T., Tang, P., Mao, S., Chan, H.-K., 2016. L-Leucine as an excipient against moisture on in vitro aerosolization performances of highly hygroscopic spray-dried powders. *Eur. J. Pharm. Biopharm.* 102, 132–141. <http://dx.doi.org/10.1016/j.ejpb.2016.02.010>.
- Licalsi, C., Christensen, T., Bennett, J.V., Phillips, E., Witham, C., 1999. Dry powder inhalation as a potential delivery method for vaccines. *Vaccine* 17, 1796–1803. [http://dx.doi.org/10.1016/S0264-410X\(98\)00438-1](http://dx.doi.org/10.1016/S0264-410X(98)00438-1).
- Lipp, M.M., Batory, R., Moore, J., Leinonen, M., Freed, M.I., 2016. Preclinical and clinical assessment of inhaled levodopa for OFF episodes in Parkinson's disease. *Sci. Transl. Med.* 8, 1–11. <http://dx.doi.org/10.1126/scitranslmed.aad8858>.
- Liu, T., Han, M., Tian, F., Cun, D., Rantanen, J., Yang, M., 2018. Budesonide nanocrystal-hyaluronic acid microparticles for inhalation: in vitro and in vivo evaluation. *Carbohydr. Polym.* 181, 1143–1152. <http://dx.doi.org/10.1016/j.carbpol.2017.11.018>.
- Loftsson, T., 2002. Cyclodextrins and the biopharmaceutical classification system of drugs. *J. Incl. Phenom. Macrocycl. Chem.* 44, 63–67.
- Luinstra, M., Grasmeyer, F., Hagedoorn, P., Moes, J.R., Frijlink, H.W., De Boer, A.H., 2015. A levodopa dry powder inhaler for the treatment of Parkinson's disease patients in off periods. *Eur. J. Pharm. Biopharm.* 97, 22–29. <http://dx.doi.org/10.1016/j.ejpb.2015.10.003>.
- Luner, P.E., Zhang, Y., Abramov, Y.A., Carvajal, M.T., 2012. Evaluation of milling method on the surface energetics of molecular crystals using inverse gas chromatography. *Cryst. Growth Des.* 12, 5271–5282. <http://dx.doi.org/10.1021/cg300785z>.
- Luyt, C.-E., Clavel, M., Guntupalli, K., Johannigman, J., Kennedy, J.I., Wood, C., Corkery, K., Gribben, D., Chastre, J., 2009. Pharmacokinetics and lung delivery of PDDS-aerosolized amikacin (NKTR-061) in intubated and mechanically ventilated patients with nosocomial pneumonia. *Crit. Care* 13, R200. <http://dx.doi.org/10.1186/cc8206>.
- Mack, P., Horvath, K., Tully, J., Maynor, B., 2012. Particle engineering for inhalation formulation and delivery of biotherapeutics. *Inhalation* 6, 16–20.
- Matilainen, L., Järvinen, K., Toropainen, T., Näsi, E., Auriola, S., Järvinen, T., Jarho, P., 2006. In vitro evaluation of the effect of cyclodextrin complexation on pulmonary deposition of a peptide, cyclosporin A. *Int. J. Pharm.* 318, 41–48. <http://dx.doi.org/10.1016/j.ijpharm.2006.03.009>.
- Mawson, S., Kanakia, S., Johnston, K.P., 1997. Coaxial nozzle for control of particle morphology in precipitation with a compressed fluid antisolvent. *J. Appl. Polym. Sci.* 64, 2105–2118. [http://dx.doi.org/10.1002/\(SICI\)1097-4628\(19970613\)64:11<2105::AID-APP6>3.3.CO;2-1](http://dx.doi.org/10.1002/(SICI)1097-4628(19970613)64:11<2105::AID-APP6>3.3.CO;2-1).
- Mohtar, N., Taylor, K.M.G., Sheikh, K., Somavarapu, S., 2017. Design and development of dry powder sulfobutylether- β -cyclodextrin complex for pulmonary delivery of fisetin. *Eur. J. Pharm. Biopharm.* 113, 1–10. <http://dx.doi.org/10.1016/j.ejpb.2016.11.036>.
- Newman, S.P., Busse, W.W., 2002. Evolution of dry powder inhaler design, formulation, and performance. *Respir. Med.* 96, 293–304. <http://dx.doi.org/10.1053/rmed.2001.1276>.
- Parumasivam, T., Chang, R.Y.K., Abdelghany, S., Ye, T.T., Britton, W.J., Chan, H.-K., 2016. Dry powder inhalable formulations for anti-tubercular therapy. *Adv. Drug Deliv. Rev.* 102, 83–101. <http://dx.doi.org/10.1016/j.addr.2016.05.011>.
- Patel, B., Gupta, N., Ahsan, F., 2015. Particle engineering to enhance or lessen particle uptake by alveolar macrophages and to influence the therapeutic outcome. *Eur. J. Pharm. Biopharm.* 89, 163–174. <http://dx.doi.org/10.1016/j.ejpb.2014.12.001>.
- Quon, B.S., Goss, C.H., Ramsey, B.W., 2014. Inhaled antibiotics for lower airway infections. *Ann. Am. Thorac. Soc.* 11, 425–434. <http://dx.doi.org/10.1513/AnnalsATS.201311-395FR>.
- Renunkuntla, J., Vadlapudi, A.D., Patel, A., Boddu, S.H., Mitra, A.K., 2013. Approaches for enhancing oral bioavailability of peptides and proteins. *Int. J. Pharm.* 447, 75–93. <http://dx.doi.org/10.1111/j.1743-6109.2008.01122.x>. *Endothelial*.
- Rojanarat, W., Changsan, N., Tawithong, E., Pitsuwan, S., Chan, H.K., Srichana, T., 2011. Isoniazid proliposome powders for inhalation-preparation, characterization and cell culture studies. *Int. J. Mol. Sci.* 12, 4414–4434. <http://dx.doi.org/10.3390/ijms12074414>.
- Sacks, L.V., Pendle, S., Orlovic, D., Andre, M., Popara, M., Moore, G., Thonell, L., Hurwitz, S., 2001. Adjunctive salvage therapy with inhaled aminoglycosides for patients with persistent smear-positive pulmonary tuberculosis. *Clin. Infect. Dis.* 32, 44–49. <http://dx.doi.org/10.1086/317524>.
- Schuster, A., Haliburn, C., Döring, G., Goldman, M.H., 2013. Safety, efficacy and convenience of colistimethate sodium dry powder for inhalation (Colobreathe DPI) in patients with cystic fibrosis: a randomised study. *Thorax* 68, 344–350. <http://dx.doi.org/10.1136/thoraxjnl-2012-202059>.
- Sellers, S.P., Clark, G.S., Sievers, R.E., Carpenter, J.F., 2001. Dry Powders of Stable Protein Formulations From Aqueous Solutions Prepared Using Supercritical CO₂-Assisted Aerosolization 90, 785–797.
- Shah, U.V., Karde, V., Ghoroi, C., Heng, J.Y.Y., 2017. Influence of particle properties on powder bulk behaviour and processability. *Int. J. Pharm.* 518, 138–154. <http://dx.doi.org/10.1016/j.ijpharm.2016.12.045>.
- Shah, S.P., Misra, A., 2004. Development of liposomal amphotericin B dry powder inhaler formulation. *Drug Deliv.* 11, 247–253. <http://dx.doi.org/10.1080/10717540490467375>.
- Sibum, I., Grasmeyer, F., Hagedoorn, P., Frijlink, H.W., 2016. Characterisation of jet-milled and spray dried isoniazid for pulmonary administration. In: *Drug Delivery to the Lungs (DDL)* 27. Edinburgh.
- Sievers, R.E., Huang, E.T.S., Villa, J.A., Kawamoto, J.K., Evans, M.M., Brauer, P.R., 2001. Low-temperature manufacturing of fine pharmaceutical powders with supercritical fluid aerosolization in a Bubble Dryer[®]. *Pure Appl. Chem.* 73, 1299–1303. <http://dx.doi.org/10.1351/pac200173081299>.
- Smith, I.J., Parry-Billings, M., 2003. The inhalers of the future? A review of dry powder devices on the market today. *Pulm. Pharmacol. Ther.* 16, 79–95. [http://dx.doi.org/10.1016/S1094-5539\(02\)00147-5](http://dx.doi.org/10.1016/S1094-5539(02)00147-5).
- Staniforth, J.N., 1987. British pharmaceutical conference science award lecture 1986: order out of chaos. *J. Pharm. Pharmacol.* 39, 329–334. <http://dx.doi.org/10.1111/j.2042-7158.1987.tb03393.x>.
- Stein, S.W., Sheth, P., Hodson, P.D., Myrdal, P.B., 2014. Advances in metered dose inhaler technology: hardware development. *AAPS PharmSciTech* 15, 326–338. <http://dx.doi.org/10.1208/s12249-013-0062-y>.
- Sung, J.C., Padilla, D.J., Garcia-Contreras, L., Verberkmoes, J.L., Durbin, D., Peloquin, C.A., Elbert, K.J., Hickey, A.J., Edwards, D.A., 2009. Formulation and pharmacokinetics of self-assembled rifampicin nanoparticle systems for pulmonary delivery. *Pharm. Res.* 26, 1847–1855. <http://dx.doi.org/10.1007/s11095-009-9894-2>.
- Tian, G., Longest, P.W., Li, X., Hindle, M., 2013. Targeting aerosol deposition to and within the lung airways using excipient enhanced growth. *J. Aerosol Med. Pulm. Drug Deliv.* 26, 248–265. <http://dx.doi.org/10.1089/jamp.2012.0997>.
- Tonnis, W.F., Lexmond, A.J., Frijlink, H.W., de Boer, A.H., Hinrichs, W.L., 2013. Devices and formulations for pulmonary vaccination. *Expert Opin. Drug Deliv.* 10, 1383–1397. <http://dx.doi.org/10.1517/17425247.2013.810622>.
- Trofast, E.A.-C., Olsson, M., Ahlneck, C., 2002. Agglomeration of finely divided powders. *US6371171B1*.
- Turner, M.T., Haskal, R., McGowan, K., Nardell, E., Sabbag, R., 1998. Inhaled kanamycin in the treatment of multidrug-resistant tuberculosis: A study of five patients.
- Vehring, R., 2008. Pharmaceutical particle engineering via spray drying. *Pharm. Res.* 25, 999–1022. <http://dx.doi.org/10.1007/s11095-007-9475-1>.
- Visser, J., 1989. Van der Waals and other cohesive forces affecting powder fluidization. *Powder Technol.* 58, 1–10. [https://doi.org/https://doi.org/10.1016/0032-5910\(89\)80001-4](https://doi.org/https://doi.org/10.1016/0032-5910(89)80001-4).
- Vyas, S.P., Kannan, M.E., Jain, S., Mishra, V., Singh, P., 2004. Design of liposomal aerosols for improved delivery of rifampicin to alveolar macrophages. *Int. J. Pharm.* 269, 37–49. <http://dx.doi.org/10.1016/j.ijpharm.2003.08.017>.
- Wang, Z., Cuddigan, J.L., Gupta, S.K., Meenach, S.A., 2016. Nanocomposite Microparticles (mCmp) for the Delivery of Tacrolimus in the Treatment of Pulmonary Arterial Hypertension 512, 305–313. <https://doi.org/10.1038/nmeth.2839.A>.
- Wang, S.H., Thompson, A.L., Hickey, A.J., Staats, H.F., 2012. Dry powder vaccines for mucosal administration: critical factors in manufacture and delivery. *Curr. Top. Microbiol. Immunol.* 354, 121–156. <http://dx.doi.org/10.1007/82>.
- Wanning, S., Süverkrüp, R., Lamprecht, A., 2017. Jet-vortex spray freeze drying for the production of inhalable lyophilisate powders. *Eur. J. Pharm. Sci.* 96, 1–7. <http://dx.doi.org/10.1016/j.ejps.2016.08.062>.
- Winters, M.A., Knutson, B.L., DeBenedetti, P.G., Sparks, H.G., Przybycien, T.M., Stevenson, C.L., Prestrelski, S.J., 1996. Precipitation of proteins in supercritical carbon dioxide. *J. Pharm. Sci.* 85, 586–594. <http://dx.doi.org/10.1021/js950482q>.
- Yang, M., Yamamoto, H., Kurashima, H., Takeuchi, H., Yokoyama, T., Tsujimoto, H., Kawashima, Y., 2012. Design and evaluation of poly(DL-lactic-co-glycolic acid) nanocomposite particles containing salmon calcitonin for inhalation. *Eur. J. Pharm. Sci.* 46, 374–380. <http://dx.doi.org/10.1016/j.ejps.2012.02.024>.
- Young, P.M., Crapper, J., Phillips, G., Sharma, K., Chan, H.-K., Traini, D., 2013. Overcoming dose limitations using the Orbital[®] multi-breath dry powder inhaler. *J. Aerosol Med. Pulm. Drug Deliv.* 27, 138–147. <http://dx.doi.org/10.1089/jamp.2013.1080>.
- Zarogoulidis, P., Chatzaki, E., Porpodis, K., Domvri, K., Hohenforst-Schmidt, W., Goldberg, E.P., Karamanos, N., Zarogoulidis, K., 2012. Inhaled chemotherapy in lung cancer: future concept of nanomedicine. *Int. J. Nanomed.* 7, 1551–1572. <http://dx.doi.org/10.2147/IJN.S29997>.
- Zhu, B., Young, P.M., Ong, H.X., Crapper, J., Flodin, C., Qiao, E.L., Phillips, G., Traini, D., 2015. Tuning aerosol performance using the multibreath Orbital[®] dry powder inhaler device: controlling delivery parameters and aerosol performance via modification of pucker orifice geometry. *J. Pharm. Sci.* 104, 2169–2176. <http://dx.doi.org/10.1002/jps.24458>.