

University of Groningen

The Tide that lifts all boats? Acquisitions and CEO-TMT pay disparity in the Netherlands

Rao Sahib, Padmavathi; van der Laan, Gerwin; van Ees, Hans

Published in:
 Management Decision

DOI:
[10.1108/MD-08-2017-0804](https://doi.org/10.1108/MD-08-2017-0804)

IMPORTANT NOTE: You are advised to consult the publisher's version (publisher's PDF) if you wish to cite from it. Please check the document version below.

Document Version
 Publisher's PDF, also known as Version of record

Publication date:
 2018

[Link to publication in University of Groningen/UMCG research database](#)

Citation for published version (APA):

Rao Sahib, P., van der Laan, G., & van Ees, H. (2018). The Tide that lifts all boats? Acquisitions and CEO-TMT pay disparity in the Netherlands. *Management Decision*, 56(9), 2038-2059.
<https://doi.org/10.1108/MD-08-2017-0804>

Copyright

Other than for strictly personal use, it is not permitted to download or to forward/distribute the text or part of it without the consent of the author(s) and/or copyright holder(s), unless the work is under an open content license (like Creative Commons).

Take-down policy

If you believe that this document breaches copyright please contact us providing details, and we will remove access to the work immediately and investigate your claim.

Downloaded from the University of Groningen/UMCG research database (Pure): <http://www.rug.nl/research/portal>. For technical reasons the number of authors shown on this cover page is limited to 10 maximum.



Management Decision

The Tide that lifts all boats? Acquisitions and CEO-TMT pay disparity in the Netherlands

Padma Rao Sahib, Gerwin Van der Laan, Hans Van Ees,

Article information:

To cite this document:

Padma Rao Sahib, Gerwin Van der Laan, Hans Van Ees, (2018) "The Tide that lifts all boats? Acquisitions and CEO-TMT pay disparity in the Netherlands", Management Decision, Vol. 56 Issue: 9, pp.2038-2059, <https://doi.org/10.1108/MD-08-2017-0804>

Permanent link to this document:

<https://doi.org/10.1108/MD-08-2017-0804>

Downloaded on: 18 October 2018, At: 03:01 (PT)

References: this document contains references to 73 other documents.

To copy this document: permissions@emeraldinsight.com

The fulltext of this document has been downloaded 78 times since 2018*

Users who downloaded this article also downloaded:

(2018), "Developing a service quality scale in context of organized grocery retail of India", Management Decision, Vol. 56 Iss 9 pp. 1969-1990 https://doi.org/10.1108/MD-08-2017-0790

(2018), "The role of R&D investments and export on SMEs' growth: a domain ambidexterity perspective", Management Decision, Vol. 56 Iss 9 pp. 1883-1903 https://doi.org/10.1108/MD-02-2017-0136



Access to this document was granted through an Emerald subscription provided by emerald-srm:211952 []

For Authors

If you would like to write for this, or any other Emerald publication, then please use our Emerald for Authors service information about how to choose which publication to write for and submission guidelines are available for all. Please visit www.emeraldinsight.com/authors for more information.

About Emerald www.emeraldinsight.com

Emerald is a global publisher linking research and practice to the benefit of society. The company manages a portfolio of more than 290 journals and over 2,350 books and book series volumes, as well as providing an extensive range of online products and additional customer resources and services.

Emerald is both COUNTER 4 and TRANSFER compliant. The organization is a partner of the Committee on Publication Ethics (COPE) and also works with Portico and the LOCKSS initiative for digital archive preservation.

*Related content and download information correct at time of download.

The Tide that lifts all boats? Acquisitions and CEO-TMT pay disparity in the Netherlands

2038

Received 31 August 2017
Revised 19 March 2018
Accepted 9 April 2018

Padma Rao Sahib

*Department of Global Economics and Management,
Faculty of Economics and Business, University of Groningen, Groningen,
The Netherlands*

Gerwin Van der Laan

*Department of Management, Tilburg School of Economics and Management,
Tilburg, The Netherlands, and*

Hans Van Ees

*Department of Global Economics and Management,
Faculty of Economics and Business, University of Groningen, Groningen,
The Netherlands*

Abstract

Purpose – The purpose of this paper is to examine how firm growth, and its decomposition into acquisitive and organic growth, can serve as an antecedent to the disparity in pay between the CEO and other top management team (TMT) members.

Design/methodology/approach – Drawing on tournament theory, the authors argue that acquisitive and organic growth strategies have different effects on CEO-TMT pay disparity.

Findings – The authors find that acquisitive growth, measured through the number and size of acquisitions, increases CEO-TMT pay disparity while organic growth has no effect on CEO-TMT pay disparity.

Practical implications – The findings, based in the context of the Netherlands, imply that boards in their monitoring activity may need to take into account the potential incentive effects of acquisitive activity as CEOs may have a greater motivation to engage in acquisitions than their fellow TMT members.

Originality/value – This paper contributes to the literature on relative compensation and incentives and the literature on managerial compensation and firm strategy. To investigate the role of firm growth in increasing CEO-TMT pay disparity, the authors adopt a fine-grained approach along two dimensions. First, the authors disaggregate firm growth into organic and acquisition driven firm growth. Second, the authors disaggregate pay disparity in these components.

Keywords Organic growth, Acquisitions, Executive compensation, CEO-TMT pay disparity

Paper type Research paper

1. Introduction

Pay disparity is a sensitive issue in the Netherlands which prides itself on being an egalitarian society. When in 2014, the findings of the Scientific Council for Government Policy in the Netherlands found that the top 10 percent of Dutch households own 61 percent of the country's net wealth, this sparked a parliamentary debate and stalled tax proposals (*The Economist*, 2014). Despite Dutch income taxes, which ensure a reasonably egalitarian distribution of post-tax incomes, this finding emphasized that the wealth distribution in the Netherlands is one of the most unequal in Europe (*The Economist*, 2014).

Although pay disparity within management boards of companies is less of an issue than pay differences between the rank and file of a company and top management, a study that found that CEOs of prominent Dutch companies such as Philips, Wolters Kluwer and Heineken earn more than twice as much as the CFO made it to the headlines of the major financial newspaper in the Netherlands and raised concerns if this was conducive to



corporate governance (Kakebeeke and Couwenbergh, 2015). Such attention to issues of pay disparity within the management board is not surprising in countries like the Netherlands where the traditional model of the management board has the CEO being the “first among equals” (Nadolska and Barkema, 2014).

This paper focuses on this second, somewhat less contentious manifestation of pay disparity – between the CEO and other top management team (TMT) members. Although this is less likely to receive publicity, research has shown that CEO-TMT pay disparity has consequences for the performance of the TMT and for firm performance. In the spirit of Graffin *et al.* (2008), Frederickson *et al.* (2010) and Tang *et al.* (2011) shifts focus to non-CEO board members who also play an important role in the management of a firm. We examine the pay gap between the CEO and other members of the management board focusing on the role of firm growth. We ask if firm growth is the “rising tide that lifts all boats[1]” within the TMT or if the CEO is the primary beneficiary of firm growth.

While research on the effectiveness of bonuses, rooting in the agency theory literature, is abundant, attention to the pay disparity between the CEO and other TMT members (henceforth CEO-TMT pay disparity) is comparatively less developed. Prior work has attended to the consequences for both the performance of the TMT and the firm. Carpenter and Sanders (2004) find that CEO-TMT pay disparity is negatively related to firm performance among multinational companies while Siegel and Hambrick (2005) find that pay disparity is detrimental to high technology firms, which require close interdependence among TMT members. In a different setting, and in contrast to the previous findings, Shaw *et al.* (2002) find that horizontal pay disparity (disparity between employees at approximately the same hierarchical level) is associated with higher workforce performance. These conflicting findings on the link between CEO-TMT pay disparity and performance are reflected in our sample as well. Philips and Wolters Kluwer, characterized by large CEO-TMT pay disparities, and in existence since the nineteenth century, are on the list of the top 100 most sustainable corporations in the world (Corporate Knights, 2015). In contrast, Imtech, also characterized by large CEO-TMT pay disparity, became bankrupt in 2015 (Dutch News, 2015). In sum, research on the consequences of pay disparity is inconclusive but abundant (Henderson and Fredrickson, 2001; Carpenter and Sanders, 2004; Siegel and Hambrick, 2005; Graffin *et al.*, 2008; Frederickson *et al.*, 2010; Ridge *et al.*, 2015; Connelly *et al.*, 2016).

Alongside research on the consequences of pay disparity, there is a body of research on the antecedents of CEO-TMT pay disparity (Graffin *et al.*, 2008; Connelly *et al.*, 2016). Graffin *et al.* (2008) show that the celebrity status of the CEO increases CEO-TMT pay disparity, while Connelly *et al.* (2016) find that the (short) horizon of institutional investors influences CEO-TMT pay disparity with short-term investors leading to greater CEO-TMT pay disparity. This paper aims to contribute to the literature by exploring firm growth as a possible antecedent of CEO-TMT pay disparity, since company size has been consistently found to drive variation in compensation (Tosi *et al.*, 2000), growth strategies appear a meaningful area of investigation to better understand CEO-TMT pay disparity. To investigate the role of firm growth in increasing CEO-TMT pay disparity, we adopt a fine-grained approach along two dimensions. First, we disaggregate firm growth into organic and acquisition driven firm growth as we expect that these different pathways to growth yield different gains for the CEO and other TMT members. Second, since the executive compensation literature suggests that the three pay components, salary, bonus, and stock (option) pay, each serve a different objective, we disaggregate pay disparity in these components.

Our disaggregated approach allows us to match the effect of firm growth strategies on pay disparity with the differential objectives of pay components. Our work contributes to two strands in the literature; the literature on relative compensation and incentives that followed

early work by Lazear and Rosen (1981) and the literature on managerial compensation and firm strategy (see surveys by Bodolica and Spraggon, 2009; Halebian *et al.*, 2009).

Our empirical examination is in the institutional setting of the Netherlands. Besides its labor friendly and social democratic aspects, the Netherlands is also known for its flexible tax policies, liberal and business-friendly environment (Poutsma and Braam, 2005). In contrast to the USA, which is characterized by dispersed shareholder ownership and a “winner-take-all” attitude, the Netherlands is far less accepting of large payoffs to CEOs. Also, unlike the USA and the UK, and other common-law countries, CEOs in the Netherlands have less power (Thomas, 2004).

The business landscape of the Netherlands is populated not only by smaller domestic firms, but also by large MNEs which are headquartered in the Netherlands, some of which have a presence in the UK or USA (Philips and Unilever for example). Such firms are likely to include features more akin to the Anglo-Saxon business model, commonly associated with a greater focus on shareholders rather than stakeholders, higher turnover and greater pay disparity. The setting of the Netherlands, which juxtaposes a more egalitarian and social approach with economic liberalism, makes an examination of pay disparity, even if it is within the TMT, relevant not only for researchers, but also for policy makers and the media.

The remainder of the paper is organized as follows. The next section, Section 2, discusses the theoretical background underlying this paper. Section 3 follows with a description of our data sources and the methodology. Section 4 is devoted to a discussion of the results of the paper. Section 5 offers some conclusions and directions for future research.

2. Theory and hypotheses

2.1 *Tournament theory, acquisitive growth and organic growth*

The commonly used theoretical framework to explain the existence and consequences of pay disparity is tournament theory, first proposed in Lazear and Rosen (1981)[2]. The core argument of tournament theory is that when performance is difficult to observe, pay differences across ranks are an efficient incentive device to elicit effort. When information on relative performance within organizations is more efficiently obtained than indicators of absolute performance, principals may incentivize managers through rank-order performance contracts. Employees at any given hierarchical level in the organization are encouraged to exert effort, as high relative performance is associated with an increased likelihood of being promoted to the next level in the organizational hierarchy. The difference in pay between two adjacent hierarchical levels is the prize of the contest among employees. At the level of the TMT, pay disparity between TMT members and the CEO serves to incentivize TMT members to work hard to achieve the prize of the CEO position.

Tournament theory proposes that pay disparity is increasing in the number of hierarchical levels in an organization and the number of contestants at each level (Lazear and Rosen, 1981; Rosen, 1992). The more contestants there are, the lower the likelihood that a particular contestant wins. Consequently, pay disparity increases to compensate for this effect. To ensure the continued eliciting of high effort across a series of contests within the firm, pay disparity increases with each subsequent contest. The greater the number of hierarchical levels (contests), the larger the pay disparity in the final tournament where the prize is the CEO position.

The main implication of tournament theory is that the size of the prize spread between the winner and other contestants elicits effort from the contestants in the tournament. Following Lazear and Rosen (1981), tournament theory has been extended to argue that the greater effort expended by contestants when prize spreads are wider implies that firms with greater pay disparity exhibit better performance (see Connelly *et al.*, 2016 for a survey and synthesis of tournament theory).

As far as the level of executive compensation is concerned, firm size is the single determinant which consistently arises as a strong predictor of executive pay (Devers *et al.*, 2007). In addition Rajan and Wulf (2006) conclude that large firms are generally more hierarchical than small firms. Given the implications of tournament theory, this implies that the greater hierarchy that accompanies firm size will result in greater pay disparity in general and greater CEO-TMT pay disparity in particular. Furthermore, Henderson and Fredrickson (2001) point out that coordination needs are higher in larger firms. In addition, larger firms demand more managerial resources, and teams of top managers need to coordinate their activities more closely (Haveman, 1993; Henderson and Fredrickson, 2001). Therefore, both CEO and TMT pay are likely to increase with firm size.

However, firms can grow large in two ways – they can “buy” size through acquisitions which result in discrete changes in firm size or they can grow organically which reflects the expansion of current businesses. We argue that these two pathways to larger size affect CEO-TMT pay disparity differently. There is broad empirical support in the finance literature for the hypothesis that financial benefits accrue to the CEO who engages in acquisitions (Grinstein and Hribar, 2004; Girma *et al.*, 2006; Harford and Li, 2007; Yim, 2013). Bebchuk (2005) shows that CEO pay is more sensitive to firm size for firms that make large acquisitions than for firms that do not. Also, Bebchuk (2005) examines a broad portfolio of firm growth strategies and shows that while CEO pay is related to organic growth; it is related to a greater extent to acquisitions. As organic growth is more likely to reside in already existing business units, it is more likely to be linked to non-CEO executive performance and compensation than linked solely to CEO compensation. In the event that growth strategies fail, the CEO being the “face” of the firm, are more likely to face higher risks of involuntary turnover than other board members (Fee and Hadlock, 2004). Research has shown that 47 percent of CEOs of acquiring firms are replaced within five years and this probability is even higher if the acquisition fails (Lehn and Zhao, 2006).

Although Boeker (1992) finds that powerful CEOs could dismiss other executives and protect their own positions when firm performance is poor, Fee and Hadlock (2004) show that once CEO dismissals are controlled for, the effect of firm performance on non-CEO dismissal is insignificant. Also, non-CEO turnover is usually determined by poor performance in an area under the control of the executive (such as the failure of a marketing campaign or a breakdown in financial reporting) rather than overall firm performance.

An implication of tournament theory which has received relatively little attention is the effect of market uncertainty on the optimal pay structure. Market uncertainty weakens the link between effort and performance. If external factors outside the control of the employee are an important factor in determining output, employees will be less motivated to work hard to win the promotion. As a result, tournament theory predicts that in settings where there is greater uncertainty in output, the wage gap has to be even wider to compensate for the detrimental effect of randomness on effort (Lazear and Rosen, 1981, Equation (6)). Empirically, this implies that large wage spreads will be observed in firms and markets characterized by a high degree of demand and output uncertainty.

Firms engaging in M&A activity are likely to experience demand and output uncertainty as new sub-units of the firm are either integrated or divested. The integration of new business units, the introduction and integration of new product lines or services are likely to introduce greater uncertainty for the firm and therefore for its TMT.

In contrast to organic growth, acquisitions increase firm size through an increase in the number of business units (SBUs) within the company. However, as the number of SBUs is more likely to grow in the case of acquisitive growth rather than in the case of organic growth, firms growing through acquisitions will be characterized by larger CEO-TMT pay disparity to compensate for the lower probability that an individual manager makes it to the CEO position. Moreover, as the CEO is the “face” of a company and acquisitions often

receive media attention, we propose that the CEO's job is more at stake when an acquisition is a failure, than when an organically growing division does not meet performance expectations. Therefore, the risk that the CEO will be forced to vacate his/her position before the contractual end-term, is likely to be larger in the case of firms that grow primarily through acquisitions. As a result, the expected present value of CEO pay is lower, as contestants discount fewer years of CEO pay. To compensate for this, acquisitive firms, compared to organically growing firms, are likely to be characterized by larger CEO-TMT pay disparity.

General trends in M&A activity also have implications for the compensation of CEOs vs others in TMT. For example, Andrade *et al.* (2001) document an increasing trend in the stock financing (in contrast to cash financing) of M&As. This increase in stock financing implies introduces additional volatility in the valuation of an M&A and consequently greater uncertainty for the CEO and other TMT members who are assessed on it success. Andrade *et al.* (2001) demonstrate that M&A activity is driven primarily by industry shocks and that M&A activity comes in waves, clustering in particular industries within waves. These findings, coupled with the quiet life hypothesis (Bertrand and Mullainathan, 2003) weaken the arguments that CEOs initiate M&As for private gain, suggesting that initiating M&A activity may be forced on firms by external conditions. Firms may be compelled to "ride the wave" driven by survival strategies popularly termed as "acquire or be acquired." In this case, as CEOs bear the most responsibility for M&A activity which is imposed on them by external circumstances, they are more likely to demand more compensation than other TMT members.

In addition, CEO-TMT pay disparity grows with firm size because larger firms are more difficult to monitor. Taken together, these arguments lead to our first hypothesis:

- H1.* The impact of acquisitive growth on CEO-TMT pay disparity is greater than the impact of organic growth on CEO-TMT pay disparity.

2.2 Acquisitive growth and components of pay

Shareholders of companies – or boards of directors on their behalf – have different pay components (fixed pay, cash bonus payments and stock-based pay) at their disposal that can be balanced to elicit performance and align interests of TMT members with shareholders.

The theory on pay disparity and the empirical literature to date do not provide much guidance as to component-dependent acquisitive growth effects. Our effort at theorizing in this section offers preliminary conjectures about the effect of acquisitive growth on the components of CEO-TMT pay disparity.

We propose that fixed pay disparity reflects the extent to which growth strategies structurally affect the contest for the CEO position. Organic growth and acquisitive growth strategies both result in a structural increase in firm complexity. However, an acquisition is more complex as it adds a distinct new entity, the target firm, to the existing firm structure. This is, in many cases accompanied by new employees, not only rank and file, but also senior management, which is to be integrated into the new combined firm. We conjecture that the larger firm size that results from acquisitive growth, and resulting increase in hierarchy (Rajan and Wulf, 2006), will be associated with greater CEO-TMT fixed pay disparity.

Bonus payments serve to stimulate individual and exceptional contributions to firm performance. Since acquisitions are specific projects with demarcated announcement and completion dates, a temporary payment such as a bonus is fitting with the discrete characteristics of the task. Empirical evidence shows that transaction bonuses are often rewarded upon the completion of a major acquisition deal, and retention bonuses are paid out if a manager stays on for a fixed time after deal closure (Grinstein and Hribar, 2004;

Mercer, 2012). Bonuses paid after acquisitions are usually a percentage of fixed salary and are linked to the completion of the deal rather than post-acquisition performance (Grinstein and Hribar, 2004; Mercer, 2012). Evidence also shows that CEOs often receive a permanent increase in compensation following acquisitions (Yim, 2013). Given that the CEO's fixed salary is larger than those of other TMT members, the bonus that the CEO receives will in most cases exceed that of other TMT members. In sum, we conjecture that acquisitive growth is associated with increasing CEO-TMT bonus disparity.

Stock and option pay is an instrument for incentive alignment between managers and shareholders. For instance, the “quiet life” hypothesis conjectures that managers do not necessarily engage in empire building through acquisitions when corporate governance is weakened (Bertrand and Mullainathan, 2003). Managerial pay may need to be incentivized to engage in growth strategies, and evidence shows that pay packages can be so designed that CEOs engage in activities that result in high-variance corporate performance (Sanders and Hambrick, 2007). We conjecture that the CEO-TMT stock and option pay disparity widens with acquisitive growth because of two factors. First, stock and option pay is an important instrument in ensuring the retention of the CEO who is a key figure in the post-acquisition integration period (also given that most stock options cannot be exercised immediately). Second, given that CEOs receive in general larger fixed income than other TMT members, we expect that the CEO's share of stock-based rewards from acquisitions would also be larger than those of other TMT members as these are often linked to fixed income. In fact, while rewards to acquisitions are usually in the form of cash bonuses, a survey of 42 firms across the world found that 30 percent reported rewarding acquisitions with both cash and equity payments (Mercer, 2012).

In sum, we suggest the following hypothesis:

- H2.* Acquisitive growth is positively associated with CEO-TMT pay disparity in all three components of pay (in fixed pay, bonus pay and stock and option pay).

The mechanisms underlying our model are illustrated in Figure 1.

3. Data and methods

3.1 Construction of the data set

Archival data on the annual compensation of all TMT members of all firms listed on the Amsterdam Stock Exchange was hand-collected from the annual reports of these firms for the period 2002-2006 as there is no electronic database on executive compensation in the Netherlands covering this period. We took advantage of a law that came into effect in 2002 that required all Dutch listed companies to disclose remuneration details of individual executives (Disclosure Remuneration and Shareholding Law or *Wijzigingswet Openbaarmaking Bezoldiging en Aandelenbezit*). The time window examined in our paper,

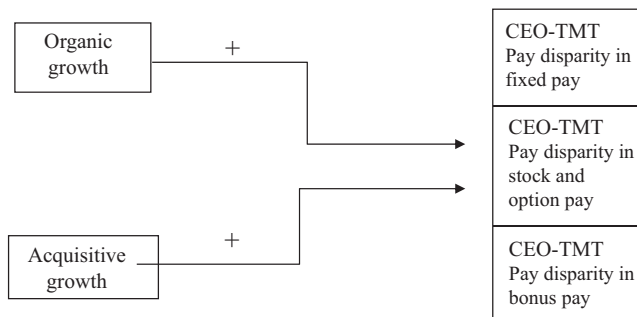

Figure 1.
The conceptual model

2002-2006 follows in the aftermath of the fifth M&A wave which is taken to be the period 1993-2001 which was the first wave characterized by strong participation of European firms (Martynova and Renneboog, 2011). Although M&A activity in the sampling frame of this paper was lower than it was during the peak of the previous wave, the period 2002-2006 marked a period of steadily increasing M&A activity in Europe and overlaps with the start of the sixth merger wave which began in 2003, in which M&A activity involving European targets surpassed the M&As in the USA (Moschieri and Campa, 2009). Given that the period overlaps with the end of one merger wave and the start of another, we are ensured of a sufficiently rich sample of deals. While equivalent statistics are not available for later M&A waves, Stearns and Allan (1996) in their analysis of the merger wave of the 1980s document that fifty percent of all M&As occur within M&A waves.

Data were collected on fixed pay, cash bonuses, and stock and option grants. Fixed pay was nearly always paid in cash and was adjusted for CEO and TMT member exits and entries. Stock and option grants are evaluated using both the Black-Scholes and the binomial formula. As the results from these two methods had a correlation of 0.99, the results from the binomial formula were arbitrarily opted for. In the cases of conditional grants (where the number granted depends on certain performance targets being reached), the expected number of options granted taking into account the number of options that would be granted at each performance level (as reported in the annual report) was computed. In contrast to most studies (Hall and Liebman, 1998), changes in the value of stock options during the sample period were taken into account. The value of the options that were not exercised or did not lapse was updated. This calculation involves taking into account conditional grants that become unconditional and incorporating expected profits from exercised options and the subsequent reduction in expected value. Total compensation was calculated taking into account all the components above and irregular cash payments (such as the value of perks), the profit derived from exercising options and the – infrequent – lapsing of option and share plans.

These data are linked with firm performance data collected from DataStream. Data on acquisitions were collected from the Zephyr database, which collects data on the M&A activity worldwide with a focus on European firms. Attention is restricted to acquisitions made by the firms in the sample, including both partial acquisitions and complete takeovers. After omitting firms whose primary listing was elsewhere, data on 107 firms over a five-year period remained. The number of observations for each type of pay disparity differs because not all firms offered their executives stock and option grants and did not pay bonuses each year. The final sample consists of 384 observations for the disparity in total pay disparity (as a result of deleting observations with missing values).

3.2 Econometric specification

To derive the estimation technique used, the following econometric model is specified for the compensation of a TMT member:

$$w_{\text{TMT},it,r} = \alpha^{\text{TMT}} + \alpha_i + \alpha_t + \beta_A^{\text{TMT}} x_{it}^A + \beta_O^{\text{TMT}} x_{it}^O + \beta_C^{\text{TMT}} x_{it}^C + \varepsilon_{\text{TMT},it} \quad (1)$$

In the above equation, $w_{\text{TMT},it,r}$ is the annual compensation of a TMT member at firm i in year t from pay component r . Compensation is specified to be a function of variables related to acquisitive growth (x_{it}^A), organic growth (x_{it}^O) and control variables denoted (x_{it}^C). In addition, fixed effects for the individual TMT member (α^{TMT}), firm specific effects (α_i), a year specific effect (α_t) and a random error term, $\varepsilon_{\text{TMT},it}$ are included. In the event that the TMT member is the CEO, the compensation equation is specified as:

$$w_{\text{CEO},it,r} = \alpha^{\text{TMT}} + \alpha^{\text{CEO}} + \alpha_i + \alpha_t + \beta_A^{\text{CEO}} x_{it}^A + \beta_O^{\text{CEO}} x_{it}^O + \beta_C^{\text{CEO}} x_{it}^C + \varepsilon_{\text{CEO},it} \quad (2)$$

In the above, the coefficients on the right hand side variables for the CEO are allowed to be different from that of other TMT members. In addition, the CEO can earn a supplement denoted α^{CEO} that is independent of the right hand side variables included in the model.

Based on the equations above, the equation for CEO-TMT pay disparity is derived as:

$$w_{\text{CEO},it,r} - w_{\text{TMT},it,r} = \alpha_t^{\text{CEO}} + (\beta_A^{\text{CEO}} - \beta_A^{\text{TMT}})x_{it}^A + (\beta_O^{\text{CEO}} - \beta_O^{\text{TMT}})x_{it}^O + (\beta_C^{\text{CEO}} - \beta_C^{\text{TMT}})x_{it}^C + \varepsilon_{\text{CEO},it} - \varepsilon_{\text{TMT},it} \quad (3)$$

Note that firm and time specific effects have been eliminated in the model above. Therefore, OLS can be used as long as the difference in the error terms is not correlated with any of the included right hand side variables. That is, external time varying factors relating to the economy at large such as inflation, that would affect both CEO and other TMT pay drop out. In the model above, the intercept may be interpreted as the “CEO premium,” the premium to the compensation of the CEO that is independent of all right hand side factors. Testing if the coefficient of x_{it}^A is greater than the coefficient of x_{it}^O in Equation (3) is a test of *H1*. Testing if the estimated coefficient of x_{it}^A is positive and significant for all components of pay is a test of *H2*.

3.3 Calculation of variables

Dependent variable. The dependent variable is the natural logarithm of the difference between CEO compensation and the median compensation of other TMT members in a calendar year (the logarithmic transformation is used to correct for skewness in the data)[3]. Most US based studies such as Henderson and Fredrickson (2001) and Main *et al.* (1993) examine the difference between the compensation of the CEO and the average of the next four highest paid managers. This is because of the requirement that a publicly listed firm in the USA need only list the compensation of the next four highest paid managers (after the CEO) in its proxy statement and “the compensation of other managers is seldom listed” (Henderson and Fredrickson, 2001, p. 103). In contrast, Dutch law requires the listing of the compensation of all TMT and board members. However, TMTs in the Netherlands are quite small. For instance, 90 percent of the sample has a TMT that consists of a CEO and four or fewer members. Therefore, CEO-TMT pay disparity is operationalized by taking the difference between CEO total compensation and the median total compensation of all other TMT members. In the cases when there was a change in the CEO in a particular year, the maximum CEO pay in that year is chosen.

Independent variables. We measure acquisitive growth by the number of acquisitions undertaken by the firm in a year and the annual average value of the deal. To distinguish between the effect of having made an acquisition at all in a particular year and the number of acquisitions, an acquisition dummy is included that is 1 if a firm conducted an acquisition in a particular year. This dummy allows firms that have not made an acquisition at all in a year to have a different intercept than those which have at least one acquisition. The number of acquisitions variable enters into the model only for those firms that completed at least one acquisition in a particular year. This specification allows for both the intercept and the slope to be different for years in which no acquisitions were made, in comparison with years when at least one acquisition was made. Excluding the dummy and including zeroes for when no acquisitions were made in a particular year, restricts the intercepts to be the same for these two cases, and allows only the slopes to be different.

The second independent variable is organic firm growth. Since sales growth is partially contaminated by acquisitive growth, a more accurate measure of organic growth is obtained from an auxiliary regression. This auxiliary regression model consists of regressing the

acquisition dummy, and the product of the number of acquisitions and the acquisition dummy and average value of the deal (averaged over the year), on sales growth. The residuals from this model can then be interpreted as sales growth with acquisitive growth “partialled out” and can be interpreted as a measure of organic firm growth (see Terza *et al.*, 2008, for an application of this technique).

Control variables. We include a number of control variables measuring the complexity of acquisitive activity. These are the average number of days to completion which is the mean number of days between the announcement and completion of a deal (taken over all deals in that year), the fraction of abandoned acquisitions which is the number of acquisitions that were initiated in a year but later withdrawn in process as fraction of all acquisitions in the same year and the fraction of cross-border acquisitions which is the number of cross-border acquisitions in a year as a fraction of all acquisitions in the same year.

In addition to the acquisition-related controls, we include firm size and TMT size to account for the fact that larger firms and a larger number of contestants imply greater CEO-TMT pay disparity. Furthermore, profit, earnings per share and absolute shareholder return are included as they are proxies for firm performance. Also, concentrated ownership has been shown to act as a monitoring device, lowering total compensation and increasing pay for performance sensitivity (Hartzell and Starks, 2003). This reduced need for monitoring can be expected to mitigate CEO-TMT pay disparity. Based on data on blockholders having a stake of at least 5 percent (collected from the Dutch Financial Authority and from a private data vendor Bureau van Dijk), the method in Hartzell and Starks (2003) is followed in order to calculate a Herfindahl index for ownership concentration (Herfindahl index ownership). Given the Dutch context of the data, an indicator of foreign ownership is included (foreign ownership) as it has been shown to lead to a more competitive and open culture among firms, a greater use of stock options in compensation and a higher emphasis on shareholder value (Barca and Becht, 2001). Lastly, we include controls for CEO and TMT turnover as firms with greater turnover may be associated with greater pay disparity. CEO turnover is an indicator variable that is 1 in a particular year if the CEO in that year is different from the year before. We have chosen to operationalize TMT turnover as the number of new TMT members (excluding the CEO) in that year since changes in the CEO are taken into account by the CEO turnover variable. Also, we include TMT size is the number of TMT members including the CEO.

3.4 Related estimation issues and robustness tests

To account for the immediate financial rewards to acquisitive activity, current period values of the independent variables relating to acquisition activity are included (Grinstein and Hribar, 2004). All other right hand side variables are lagged one period as compensation is based on past firm performance, and to address potential endogeneity issues. There is no evidence of heteroscedasticity (most likely because the logarithmic transformation of the dependent variable is used which is known to ameliorate heteroscedasticity problems). While the logarithm of the 1 + difference (to ensure that differences of zero enter the model) is used[4]. Results are reported based on the median compensation of other TMT compensation as the median is known to be less prone to extreme values[5]. Lastly, the use of the number of employees instead of sales as a measure of firm size left the results unchanged.

Our econometric model allows an estimation of the model with OLS as unobserved firm and time effects would be eliminated because of differencing. Nevertheless, as an additional robustness test, a Hausman test was implemented which indicated that the null hypothesis of no correlation between the right-hand side variables and the error term ($p = 0.262$) could not be rejected. A Breusch Pagan Lagrange Multiplier test (Wooldridge, 2002) was next

implemented to determine whether an assumption could be made that the error term in Equation (3) was independent of the right hand side variables and, thus, if we could treat the data as a pooled cross-sectional data set. The test indicates that we cannot assume that the error term is independently distributed. Therefore, the approach advocated by Pollock *et al.* (2008) is followed. The model is estimated with OLS using clustered standard errors that account for within-firm correlation. This approach is similar to using a random effects estimation as it also addresses the issue of lack of independence due to multiple observations from the same firm. This method is applied rather than a random effects estimation because it has the advantage of giving consistent estimates across a broad range of possible correlations (Cameron and Trivedi, 2009). A Wald test was also conducted for serial correlation for panel data (Wooldridge, 2002) and could not reject the null hypothesis of no serial correlation.

4. Discussion of results

4.1 Descriptive results

Average CEO-TMT pay disparity in the sample is EUR596,615.5 ranging from no disparity at all (for three cases) to a maximum of EUR10 million. The average CEO total compensation in the sample is about EUR1.17 million while the average non-CEO TMT compensation is EUR970,462. There is substantial variation in the pay of both CEO and other TMT members in the sample. Table AI displays summary statistics and correlations relevant to the model with the logarithm of pay disparity, which does not show any evidence of multicollinearity[6]. Summary statistics and correlations for the logarithm of CEO pay and other TMT pay which are relevant to the analyses are also presented in the last two rows of Table AI. Again, no evidence of multicollinearity is found.

4.2 Regression models for CEO-TMT pay disparity

Effect of independent variables. Table I presents the results from estimating model (3) for CEO-TMT pay disparity for total pay and other components of pay[7]. In *H1*, we argue that

Dependent variable	(1) Log total pay disparity	(2) Log cash disparity	(3) Log bonus disparity	(4) Log stock/options disparity
Acquisition dummy	0.0482 (0.238)	-0.00126 (0.264)	0.516 (1.051)	0.494 (1.429)
Number of acquisitions	0.137*** (0.0301)	0.0815** (0.0404)	0.193*** (0.0709)	0.142 (0.191)
Average acquisition deal value	0.0968 (0.267)	0.0253 (0.264)	-0.235 (0.931)	-3.161 (2.710)
Lagged organic firm growth	0.427 (0.293)	-0.0520 (0.300)	-0.676 (1.395)	-1.790 (2.087)
Average length of acquisition negotiations	0.000802 (0.00111)	0.000864 (0.000942)	0.000900 (0.00480)	0.0176*** (0.00564)
Fraction abandoned acquisitions	0.210 (0.233)	0.0824 (0.186)	0.595 (0.928)	1.116 (1.316)
Fraction cross-border	0.628** (0.243)	0.587** (0.227)	0.784 (0.802)	2.649* (1.544)
Lagged firm size	0.197* (0.0998)	0.280** (0.112)	0.503* (0.261)	0.137 (0.321)
Lagged board size	0.0758 (0.124)	0.0672 (0.113)	0.293 (0.334)	0.665* (0.383)
Lagged profit	-0.193 (0.561)	0.191 (0.482)	4.923 (4.056)	4.498 (5.936)
Lagged earnings per share	0.0209 (0.0623)	0.0981 (0.0615)	0.0205 (0.245)	-1.303 (0.495)
Lagged absolute shareholder return	0.217 (0.131)	0.206 (0.125)	1.199** (0.489)	-0.268 (0.850)
Lagged Herfindahl ownership	-0.00825 (0.0686)	0.00662 (0.0811)	0.0232 (0.334)	-0.577 (0.398)
Lagged foreign ownership	0.0152 (0.340)	0.0581 (0.367)	-0.408 (1.333)	-0.0425 (1.574)
Lagged CEO turnover	0.233 (0.220)	-0.348 (0.411)	-0.0885 (1.047)	2.145** (1.048)
Lagged TMT turnover	0.0876 (0.156)	0.282 (0.185)	-0.00484 (0.423)	-0.550 (0.499)
Constant	11.34*** (0.325)	10.79*** (0.321)	6.165*** (1.469)	4.792*** (1.694)
Observations	384	384	289	245
R ²	0.208	0.172	0.170	0.268

Notes: Standard errors in parentheses. * $p < 0.1$; ** $p < 0.05$; *** $p < 0.01$

Table I.
Regression models
of CEO-TMT
pay disparity

the effect of acquisitive growth is greater than the effect of organic growth on CEO-TMT pay disparity. Our results show in fact that while the effect of organic growth is statistically insignificant, acquisitive growth as measured by the number of acquisitions[8] increases CEO-TMT pay disparity for total pay and all other components with the exception of stock and option pay. Therefore, we have support for *H1*. We also have support for *H2* as we find that acquisitive growth (as measured by the number of acquisitions) has a statistically significant and positive effect on CEO-TMT pay disparity for all components of pay except stock and option pay (in this case, the effect is statistically insignificant).

There is also evidence that acquisitive growth increases CEO-TMT bonus pay disparity more than CEO-TMT pay disparity in other components of pay. Examining if this conjecture is supported involves comparing models with different dependent variables. Therefore, marginal effects (in terms of elasticities) calculated at the means of all the explanatory variables. These marginal effects give an estimate of the magnitude of the effects of the explanatory variables and, in particular, how they compare to each other. We find that all other factors being the same, an additional acquisition (capturing acquisitive growth) increases CEO-TMT bonus pay disparity by 4.31 percent. In comparison, an additional acquisition increases cash disparity by 1 percent and has no effect on the disparity in stock and option grants.

Effect of control variables. Among the control variables related to acquisitions, we find that cross-border acquisitions increases CEO-TMT pay disparity in total compensation through stock and option pay and cash pay but surprisingly not through bonus pay. CEO-TMT pay disparity is positively affected by the duration of acquisition negotiations but this effect is statistically significant only for the more long term component, stock and option pay. This suggests that cross-border deals and lengthy deal negotiations, perhaps involving the terms of payment, are acknowledged as increasing the complexity of the task activity and effort by a CEO.

Among control variables relating to the firm, firm size is found to be significant in determining CEO-TMT pay disparity for total pay and for all components of pay except stock and options, lending support to the tournament model. While profits and earnings per share do not have a significant effect on CEO-TMT pay disparity, absolute shareholder return widens disparity in total pay, cash and bonus pay which confirms our expectations. Similarly, while foreign ownership is insignificant, concentrated ownership reduces the pay disparity in stock and option grants. This is as expected as dispersed owners are less likely to vigorously monitor the CEO, and resort to incentive alignment instead. Also, firms with higher CEO turnover are characterized by greater CEO-TMT pay disparity. Finally, the significance of the intercept term yields evidence of the presence of the “CEO premium” derived in Equation (3) suggesting the presence of unobservable variables that contribute to the pay of the CEO over other TMT members.

4.3 Disaggregating effects on CEO-TMT pay disparity

The analyses from Table I reveal that the CEO-TMT pay disparity is influenced by the number of acquisitions, but the mechanisms by which this occurs is unknown. Do acquisitions benefit the entire TMT with the CEO taking the lion’s share of the gains from an acquisition? Or do acquisitions increase the CEO-TMT pay disparity by increasing CEO compensation alone while leaving the compensation of TMT members unchanged? To answer this question, two additional models (Equations (1) and (2)) for CEO and other TMT compensation are estimated. These estimation results are presented in Tables II and III, and the most relevant effects are summarized in Table IV. Note that as expressed in Equations (1) and (2), firm and time effects need to be accounted for, unlike the case of the pay disparity equation[9].

Acquisitions and CEO-TMT pay disparity

2049

Table II.
Regression models
of CEO pay

Dependent variable	(1) Log total CEO pay	(2) Log CEO cash pay	(3) Log CEO bonus pay	(4) Log CEO stock/options
Acquisition dummy	-0.008 (0.141)	-0.018 (0.122)	0.753 (0.855)	0.998 (1.212)
Number of acquisitions	0.077*** (0.019)	0.051*** (0.017)	0.191** (0.075)	0.158 (0.167)
Average acquisition deal value	0.109 (0.179)	0.079 (0.144)	-0.171 (0.552)	-0.013 (0.746)
Lagged organic firm growth	0.242 (0.263)	0.016 (0.127)	1.056 (1.117)	-2.059 (1.967)
Average length of acquisition negotiations	0.001 (0.001)	0.001 (0.001)	0.010* (0.005)	0.012* (0.007)
Fraction abandoned acquisitions	0.071 (0.158)	0.050 (0.103)	1.326 (0.876)	0.717 (1.287)
Fraction cross-border	0.319** (0.150)	0.199* (0.117)	0.254 (0.682)	0.943 (1.347)
Lagged firm size	0.153** (0.070)	0.178*** (0.064)	0.491** (0.226)	0.629** (0.297)
Lagged board size	0.193*** (0.053)	0.150*** (0.039)	0.128 (0.242)	0.603* (0.310)
Lagged profit	-0.138 (0.598)	0.033 (0.312)	5.142* (2.889)	0.431 (3.736)
Lagged earnings per share	-0.008 (0.032)	0.032 (0.021)	0.045 (0.270)	-0.731** (0.291)
Lagged absolute shareholder return	0.154* (0.093)	0.102 (0.064)	1.008** (0.463)	0.517 (0.773)
Lagged Herfindahl ownership	-0.052 (0.064)	-0.013 (0.056)	-0.086 (0.273)	-0.932*** (0.338)
Lagged foreign ownership	0.173 (0.160)	0.257** (0.129)	0.358 (1.236)	-0.190 (1.414)
Lagged CEO turnover	-0.037 (0.166)	-0.126 (0.129)	-0.333 (1.080)	0.641 (0.864)
Lagged TMT turnover	-0.060 (0.066)	0.021 (0.058)	-0.216 (0.439)	-1.028** (0.479)
Constant	12.597*** (0.206)	12.403*** (0.148)	7.567*** (1.180)	5.648*** (1.469)
Observations	422	422	422	408
R ²	0.416	0.494	0.175	0.255

Notes: Standard errors in parentheses. * $p < 0.1$; ** $p < 0.05$; *** $p < 0.01$

Dependent variable	(1) Log total other TMT pay	(2) Log other TMT cash pay	(3) Log other TMT bonus pay	(4) Log other TMT stock/options
Acquisition dummy	0.083 (0.271)	0.135 (0.269)	0.674 (0.964)	0.984 (1.220)
Number of acquisitions	0.026 (0.021)	0.011 (0.019)	0.060 (0.095)	0.025 (0.141)
Average acquisition deal value	0.633*** (0.239)	0.456 (0.394)	2.337*** (0.816)	-1.179 (2.151)
Lagged organic firm growth	-0.424 (0.418)	-0.511 (0.406)	0.613 (0.957)	-1.695 (2.035)
Average length of acquisition negotiations	0.002** (0.001)	0.002** (0.001)	0.005 (0.004)	0.016*** (0.005)
Fraction abandoned acquisitions	0.183 (0.187)	0.231 (0.204)	1.402 (0.874)	1.630* (0.965)
Fraction cross-border	-0.104 (0.397)	-0.194 (0.381)	0.219 (0.787)	1.700 (1.286)
Lagged firm size	0.077** (0.037)	0.072** (0.028)	0.269 (0.177)	-0.035 (0.215)
Lagged board size	0.194*** (0.047)	0.197*** (0.055)	0.195 (0.300)	1.149*** (0.315)
Lagged profit	-0.216 (0.443)	-0.817 (0.558)	7.208** (3.441)	-3.486 (5.170)
Lagged earnings per share	-0.012 (0.068)	0.033 (0.076)	0.084 (0.275)	-0.596 (0.414)
Lagged absolute shareholder return	-0.303 (0.221)	-0.332 (0.210)	0.875 (0.536)	0.149 (0.740)
Lagged Herfindahl ownership	0.052 (0.058)	0.090 (0.068)	-0.113 (0.312)	-0.645* (0.365)
Lagged foreign ownership	0.239 (0.271)	0.544** (0.252)	0.067 (1.023)	-0.467 (1.408)
Lagged CEO turnover	0.237** (0.111)	0.150 (0.117)	1.170 (0.785)	1.585 (0.995)
Lagged TMT turnover	-0.022 (0.097)	0.040 (0.086)	-0.136 (0.336)	-1.325*** (0.472)
Constant	12.143*** (0.330)	11.719*** (0.386)	6.279*** (1.266)	2.584 (1.772)
Observations	882	799	810	698
R ²	0.158	0.146	0.125	0.292

Notes: Standard errors in parentheses. * $p < 0.1$; ** $p < 0.05$; *** $p < 0.01$

Table III.
Regression models of
other TMT pay

Table IV.
Summary of results on CEO-TMT pay disparity, CEO pay and other TMT pay

Dependent variable	(1) Log CEO-TMT pay disparity	(2) Log CEO pay	(3) Log other TMT pay
Number of acquisitions	Positive	Positive	Insignificant
Lagged organic firm growth	Insignificant	Insignificant	Insignificant
Average length of acquisition negotiations	Positive	Positive	Positive
Board size, firm size	Positive	Positive	Positive
Lagged absolute shareholder return	Positive	Positive	Insignificant
Average acquisition deal value	Insignificant	Insignificant	Positive
Lagged foreign ownership	Insignificant	Positive	Positive
Lagged profit	Insignificant	Positive	Positive
Fraction cross-border	Positive	Positive	Insignificant

Notes: Positive and negative effects are listed only if significant; effects are for one or more components of pay

Overall, the effect of acquisitive growth on CEO compensation and the compensation of other TMT members is not uniform. We find that while the CEO benefits from the number of acquisitions, other TMT members do not. Therefore, the volume of acquisitive activity increases CEO-TMT pay disparity through increasing the compensation of the CEO, but not of other TMT members. While other TMT members gain somewhat from larger acquisition size, the effect, though statistically significant, is modest; a 1 percent increase in average deal value increases the pay of other TMT members by 1 percent. This finding may raise potential tension with CEOs preferring a strategy involving multiple acquisitions, while other TMT members may opt for fewer but larger deals. Both CEOs and other TMT members do not benefit from organic growth, regarding our earlier premise that the monetary benefits of organic growth may reside in the sub-units of the firm where it originates.

Regarding variables involving the complexity of acquisitive activity, although both the CEO and other TMT members receive more pay when deals are lengthy, the effects depend on the pay component with CEOs being rewarded more through bonuses. Cross border deals seem to benefit the CEO but do not matter for other TMT members, and contribute to CEO-TMT pay disparity. Given our country setting, this result might be explained by the large number of acquisitions in the USA by Dutch companies and reflects a diffusion of a CEO primacy culture to the Netherlands.

Regarding firm-related variables, CEOs take the lion's share of the benefits of working at large firms, and although other TMT members benefit, they do so to a lesser extent. Both CEOs and TMT members gain from working in larger boards but this does not contribute to CEO-TMT pay disparity. Concentrated ownership lowers pay in stock and option grants for both the CEO and other TMT members but the increased monitoring that is said to accompany concentrated ownership does not seem to target the CEO more than other TMT members. CEOs benefit from better firm performance as measured by higher absolute shareholder returns, but other TMT members do not. Lastly, while firms with higher turnover among CEOs have higher paid CEOs, firms with higher turnover among other TMT members, pay these other TMT members less, at least in stock and option pay. Also, there are no cross-over effects, TMT turnover does not affect CEO pay and vice versa.

Where profits are concerned, they only affect bonus pay for the CEO and other TMT members but more profitable firms do not reward their CEOs particularly more or less than other TMT members with respect to this pay component.

Effects for absolute shareholder return also show differential effects for the CEO and other TMT members, increasing CEO pay while seemingly leaving other TMT members unaffected.

In contrast and in line with past findings, concentrated ownership seems to reduce the stock and option grants of all TMT members (the CEO included). Overall, our findings paint a mixed picture but indicate that CEO pay is more sensitive to growth than TMT pay.

5. Conclusion and scope for further research

In the aftermath of the financial crisis, politicians from countries in Europe looked into possibilities to restrain the bonus culture that is considered one of the driving forces behind the economic downturn. Related to this, the Financial Stability Board (FSB), an international body that monitors and makes recommendations about the global financial system, issued principles of sound compensation, which indeed led to the restructuring of compensation practices in FSB jurisdictions. At least in the case of banks, Cerasi *et al.* (2017) find that post-crisis, compensation has become less sensitive to short-term performance and more (negatively) sensitive to risk-taking. Also, the European Union ruled that bankers' bonuses can only exceed 50 percent of total compensation after a qualified majority of shareholders consent. Indeed, in the UK, *The Guardian* reported that there was overwhelming evidence that "the City's bonus culture is bad for consumers, bad for customers, bad for the economy and even bad for the individuals themselves" (*The Guardian*, 2016). The shift away from bonuses implies a reevaluation of what a "fair" amount of compensation would be for the tasks carried out by a CEO. This also involves recalibrating the company-internal pay structure and attending to pay differences within TMTs.

However, examining company-internal structure cannot be divorced from the country context in which these companies are embedded. This motivation underlies the substantial literature in international business that has investigated how differences in the structure of organizations across countries reflect differences in cultural beliefs (Hofstede, 2011). For example, Aggarwal *et al.* (2008) document how there are systematic differences in governance practices across countries. Unlike the USA and the UK, and similar to the composition of boards in Germany, which require substantial labor representation on the board, Dutch firms are also required by law to include labor representation. For example, in the Netherlands, works councils have the right to nominate up to one third of the members of supervisory boards in larger companies, specifically those with 100 or more employees. Also, work councils are represented at shareholder meetings where supervisory board members are nominated. In the case of public limited companies, such work councils can even have an input on remuneration policy, appointments and dismissals, on major changes in the identity of a company. Although there is no requirement for the shareholders to take account of the views of the works council, such governance structures are likely to deter excessive pay differences between top managers and rank and file and also amongst top managers. In addition to affecting internal pay structures, these differences in governance structures, which arise from differences in shared values (i.e. culture) are likely to be associated with differences in attitudes toward, and the resulting structure of tournaments leading to the CEO position. While tournament structures are traditionally associated with greater incentives, they may create increased turnover. Based on data from the USA, Kale *et al.* (2014) shows that turnover among vice presidents is higher when the tournament structure they face is steeper. In a recent study, Burns *et al.* (2017) use cross country data and find that tournament structures vary systematically with firm and country cultural characteristics. Among factors affecting tournament structures, cultural values of power distance, perceptions of fair income differences and competition are associated with variations in tournament structures and with firm value. They also find that larger pay gaps in the Netherlands are negatively associated with firm value, in contrast to more Anglo-Saxon settings such as the USA and the UK.

Such divergent findings also emphasize the need for an in-depth analysis of non-US contexts, which is our attempt in this paper. By examining firm growth, and its decomposition into acquisitive and organic growth, this paper has investigated if this can be a pathway to

increasing disparity in pay between the CEO and other TMT members. We find that acquisitive growth, measured through the number and size of acquisitions, contributes to increasing CEO-TMT pay disparity. Although supervisory boards are admittedly responsible for CEO and other TMT pay, both acquisitive growth and the CEO-TMT are to a large extent, susceptible to CEO decision making. This implies the possibility that with a “serially acquiring” CEO, CEO-TMT pay may evolve more or less independent of a supervisory board, particularly if ownership is dispersed. This could be attributed to CEO hubris, a CEO’s exaggerated self-confidence or pride (Hayward and Hambrick, 1997). This exaggerated self-confidence could be associated with poorer decision making such as CEOs paying too much for acquisitions and being more likely to undertake value-destroying mergers. However, practitioners and policy makers should be aware that it is possible to alter this trajectory. Take for example, the natural experiment that was afforded by the passage of say on pay (SoP) rulings across different countries. To facilitate a closer alignment of shareholders’ interests with those of boards and TMTs, 11 developed countries passed legislation between 2000 and 2012 to give shareholders direct influence on executive compensation policies (called SoP laws), and several countries followed suit in the time period following (Correa and Le, 2016). Empirical evidence has shown that following SoP laws, the CEO’s portion of total top management pay decreased, thus reducing CEO-TMT pay disparity. What is more, following the passage of SoP laws, firm value increased. Although we cannot attribute the increase in firm value entirely to the reduction in CEO-TMT pay disparity as a result of SoP rulings, the evidence is suggestive that SoP rulings through increasing scrutiny on pay, reduce managerial pay inequality within the TMT. This is then associated with a better functioning TMT and consequently, better firm performance. HR experts and strategists should not that this illustrates that policy can in fact be used effectively to incentivize the CEO and other TMT managers.

Regarding the evidence uncovered in this paper, it seems that there is a difference in the responsibility associated with acquisitions, which then results in greater rewards for the CEO than for other TMT members. Through the disaggregated approach we adopt in studying CEO-TMT pay disparity, we are able to show that the disparity is much wider in some components of pay than in others. Acquisitive growth drives bonus disparity while it less important in determining the disparity in other components of pay such as stock and option grants or cash.

How are the gains to acquisitions distributed between the CEO and other TMT members? Are to answer this question and to compare our findings with studies that focus solely on the CEO, we examine CEO pay and the pay of other TMT members in response to acquisitive behavior. The findings show that in general, acquisitive growth has a much larger effect on CEO compensation that it has on the pay of other TMT members. Even more revealing, the number of acquisitions has no effect on the pay of other TMT members. In contrast, all components of CEO pay, with the exception of stock and option grants, are positively affected by the number of acquisitions made. Consequently, it appears that firm growth, at least in the form of acquisitive growth, benefits the CEO rather than reflecting the “tide that lifts all boats” within the TMT. This finding need not oppose tournament theory reasoning: while acquired growth increases the number of contestants for TMT positions, the likelihood that a senior manager obtains a TMT seat declines with the larger number of contestants.

Our results indicate that CEOs (rather than other TMT members) are the main beneficiary of acquisitive activity. This may arise from the nature of the function of the CEO in relation to the functions of the others in the TMT. In a recent survey among CFOs of major US companies, one finding that emerged was that “CFOs are carefully confident, but many appear to be holding back from investing and seeking to grow their businesses” (The Financial Executive, 2013). Either driven personal ambitions or by outside expectations, it is CEOs (rather than other TMT members) that have an incentive to engage in empire building through acquisitions.

Taking this argument further, it could be speculated whether this could be an explanation for the empirical puzzle of why M&A activity continues to be pervasive despite reported failure rates of M&As which are 50 percent or higher (Saxton and Dollinger, 2004; Brouthers *et al.*, 1998). While researchers have explored various reasons for the failure of M&As, such as differences in corporate culture (Navahandi and Malekzadeh, 1988), lack of synergy (Barney, 1988) and poor post-acquisition integration (Jemison and Sitkin, 1986), the evidence presented in this paper indicates that problems could also arise as a result of the incentive structure of an acquiring firm's TMT. While the CEO is rewarded for acquisitions, other TMT members are not, and yet, other TMT members may eventually share the responsibility for the implementation of acquisitions that are initiated by the CEO. Therefore, whereas the CEO may have an incentive to pursue growth through acquisitions, the reduced incentives to other TMT members from acquisitions may contribute to the eventual failure of the acquisition.

The evidence on CEO-TMT pay disparity uncovered in this paper yields a far more nuanced picture of the view that "TMT members in the Dutch context tend to act more as a team of equals" (Nadolska and Barkema, 2014, p. 1489). The evidence rather indicates that the Netherlands, at least within its TMT, may be somewhat more Anglo-Saxon than it may be perceived to be, at least where it comes to rewards to acquisitive activity, notwithstanding the Rhineland archetype of two-tier boards. Future research may explore whether these findings extend to countries where the difference between the CEO and TMT decision-making power is more substantial and structurally embedded within the organization (Hambrick *et al.*, 2015).

Our findings have implications for supervisory boards and their remuneration committees, which have influence on the pay of the CEO and other TMT members. These bodies must also take into account that the evidence in this paper suggests that while concentrated ownership reduces pay (as predicted by Hartzell and Starks, 2003) and reduces pay disparity, this effect seems to hold for stock and option pay only.

While the motivation for M&A activity may reflect the strategic intent of the company, our findings point to potential incentive effects of acquisitive activity on non-CEO TMT members that should be attended to (Wright *et al.*, 2007). Supervisory boards and remuneration committees could leverage different pay components to "smoothen" out incentive effects emerging from the differential rewards to acquisitive activity to the TMT and show a greater intervention in strategy. As Heyden *et al.* (2015) suggest, this implies an expanded role for non-executive directors in the Rhineland archetype (which applies to Dutch firms) that goes beyond monitoring alone.

This paper also raises the issue of dynamic effects. Acquisitive CEOs may engage in acquisitions which are likely to be noticed and rewarded in the short term and thus further widen CEO-TMT pay disparity (which has been predicted by tournament theory to be in place to encourage the productivity of other TMT members). Therefore, as an antecedent of CEO-TMT pay disparity, past firm growth strategies and, in particular, acquisitive growth may play a role. Can we understand these processes better by examining characteristics of CEOs and their acquisitive activities at their previous employers? Such questions and their implications for new theories and empirical analyses are topics of future research.

Notes

1. This quote, often incorrectly attributed to John F. Kennedy, was apparently taken from a slogan on the wall in the regional chamber of commerce in New England and refers to the view that economic policies that focus on macroeconomic issues would eventually benefit all individuals.
2. Other theories used to understand CEO-TMT pay disparity are social equity theory (Cowherd and Levine, 1992) and social comparison theory (Wallace and Fay, 1983). Social equity theory predicts that individuals judge the fairness of their exchange relationships by comparing the balance between the inputs they contribute (work effort and skills) and the outcome they receive (pay). Social comparison theory predicts that individuals rationalize and justify pay differences by making subjective

comparisons of the ratio of their own input to outcome and compare those to the efforts to outcomes of others (Wallace and Fay, 1983). In this setting, these alternative theories would imply that greater compensation to the CEO (relative to other TMT members) would be acceptable if the common view is that the CEO's inputs toward acquisitive growth are greater than those of other TMT members.

3. Note that an alternative specification would be to examine the effects of the independent and control variables on the change in the pay disparity over time. This specification has the attractive feature that can identify whether disparity increases over time. However, such an exercise demands a much longer time span of data than what is available to reveal any effects.
4. An alternative specification would be the difference of the natural logarithm of CEO compensation and the natural logarithm of other TMT compensation. In fact, this specification is standard practice in the analysis of wages and earnings (Manning, 1998). However, as this paper focuses on disparity in actual compensation, we examine the disparity directly and using the logarithmic transformation only to correct for the skewness of the data was chosen.
5. Estimating the model with the average instead of the median for other TMT members and the average of CEO compensation instead of the maximum (when there was more than one CEO in a year) produced similar results.
6. For the sake of brevity, correlations for the disparity in the components of pay (these are available from the authors upon request) are not reported. The correlations for the disparity in cash pay are, as expected, very similar to those of total pay.
7. To ease interpretation and ensure that coefficients are comparable in size, average firm size is scaled by 10 billion euros, average profit by 10,000 euros, average deal value by 1 million euros and the Herfindahl index by 1,000. This scaling is also used in the results presented in Tables II and III. For brevity, we do not report the coefficients of the acquisition dummy, the fraction of abandoned acquisitions and earnings per share. While these are included in the estimations, they are statistically insignificant.
8. We have chosen to use current values of the number of acquisitions to be in line with how past literature has operationalized the relationship between acquisitive activity and CEO/TMT pay. In alternative specifications not reported here, we have estimated the model with lagged acquisitive activity included. These variables were statistically insignificant and their inclusion did not change the estimated coefficients of other variables.
9. We include time varying effects by including year dummies which we found to be statistically insignificant. For brevity, these are not included in the tables.

References

- Aggarwal, R., Erel, I., Stulz, R. and Williamson, R. (2008), "Differences in governance practices between US and foreign firms: measurement, causes, and consequences", *The Review of Financial Studies*, Vol. 22 No. 8, pp. 3131-3169.
- Andrade, G., Mitchell, M. and Stafford, E. (2001), "New evidence and perspectives on mergers", *Journal of Economic Perspectives*, Vol. 15 No. 2, pp. 103-120.
- Barca, F. and Becht, M. (Eds) (2001), *The Control of Corporate Europe*, Oxford University Press, Oxford.
- Barney, J.B. (1988), "Returns to bidding firms in mergers and acquisitions, reconsidering the relatedness hypothesis", *Strategic Management Journal*, Vol. 9 No. S1, pp. 71-78.
- Bebchuk, L. (2005), "The growth of executive pay", *Oxford Review of Economic Policy*, Vol. 21 No. 2, pp. 283-303.
- Bertrand, M. and Mullainathan, S. (2003), "Enjoying the quiet life? Corporate governance and managerial preferences", *Journal of Political Economy*, Vol. 111 No. 5, pp. 400-421.
- Bodolica, V. and Spraggon, M. (2009), "Merger and acquisition transactions and executive compensation: a review of the empirical evidence", *Academy of Management Annals*, Vol. 3 No. 1, pp. 109-181.
- Boeker, W. (1992), "Power and managerial dismissal: scapegoating at the top", *Administrative Science Quarterly*, Vol. 37 No. 3, pp. 400-421.

- Brouters, K.D., van Hastenburg, P. and van den Ven, J. (1998), "If most mergers fail why are they so popular?", *Long Range Planning*, Vol. 31 No. 3, pp. 347-353.
- Burns, N., Minnick, K. and Starks, L. (2017), "CEO tournaments: a cross-country analysis of causes, cultural influences, and consequences", *Journal of Financial and Quantitative Analysis*, Vol. 52 No. 2, pp. 519-551.
- Cameron, A.C. and Trivedi, P.K. (2009), *Microeconometrics Using Stata*, Stata Press, TX.
- Carpenter, M.A. and Sanders, W.G. (2004), "The effects of top management team pay and firm internationalization on MNC performance", *Journal of Management*, Vol. 30 No. 4, pp. 509-528.
- Cerasi, V., Deininger, S., Gambacorta, L. and Oliviero, T. (2017), "How post-crisis regulation has affected bank CEO compensation (April 2017)", Working Paper No. 630, Bank for International Settlements, Basel, April.
- Connelly, B.L., Haynes, K.T., Tihanyi, L., Gamache, D.L. and Devers, C.E. (2016), "Minding the gap antecedents and consequences of top management-to-worker pay dispersion", *Journal of Management*, Vol. 42 No. 4, pp. 862-885.
- Corporate Knights (2015), "2015 Global 100", available at: www.corporateknights.com/reports/2015-global-100/ (accessed August 23, 2016).
- Correa, R. and LeI, U. (2016), "Say on pay laws, executive compensation, pay slice, and firm valuation around the world", *Journal of Financial Economics*, Vol. 122 No. 3, pp. 500-520.
- Cowherd, D.M. and Levine, D.I. (1992), "Product quality and pay equity between lower-level employees and top management, an investigation of distributive justice theory", *Administrative Science Quarterly*, Vol. 37 No. 2, pp. 302-320.
- Devers, C.E., Cannella, A.A., Reilly, G.P. and Yoder, M.E. (2007), "Executive compensation, a multidisciplinary review of recent developments", *Journal of Management*, Vol. 33 No. 6, pp. 1016-1072.
- Dutch News (2015), "Imtech declared bankrupt; divisions up for sale", available at: www.dutchnews.nl/news/archives/2015/08/imtech-declared-bankrupt-divisions-up-for-sale/ (accessed May 11, 2016).
- Fee, C.E. and Hadlock, C.J. (2004), "Management turnover across the corporate hierarchy", *Journal of Accounting and Economics*, Vol. 37 No. 1, pp. 3-38.
- Frederickson, J.W., Davis-Blake, A. and Sanders, W.M.G. (2010), "Sharing the wealth, social comparisons and pay dispersion in the CEO's top team", *Strategic Management Journal*, Vol. 31 No. 10, pp. 1031-1053.
- Girma, S., Thompson, S. and Wright, P.W. (2006), "The impact of merger activity on executive pay in the United Kingdom", *Economica*, Vol. 73 No. 290, pp. 321-339.
- Graffin, S., Wade, J., Porac, J. and McNamee, R. (2008), "The impact of CEO status diffusion on the economic outcomes of other senior managers", *Organization Science*, Vol. 19 No. 3, pp. 457-474.
- Grinstein, Y. and Hribar, P. (2004), "CEO compensation and incentives, evidence from M&A bonuses", *Journal of Financial Economics*, Vol. 73 No. 1, pp. 119-143.
- Haleblian, J., Devers, C.E., Carpenter, M.A., McNamara, G. and Davidson, R. (2009), "Taking stock of what we know about mergers and acquisitions: a review and research agenda", *Journal of Management*, Vol. 35 No. 3, pp. 469-502.
- Hall, B. and Liebman, J. (1998), "Are CEOs really paid like bureaucrats?", *Quarterly Journal of Economics*, Vol. 113 No. 3, pp. 653-691.
- Hambrick, D.C., Humphrey, S.E. and Gupta, A. (2015), "Structural interdependence within top management teams: a key moderator of upper echelons predictions", *Strategic Management Journal*, Vol. 36 No. 3, pp. 449-461.
- Harford, J. and Li, K. (2007), "Decoupling CEO wealth and firm performance: the case of acquiring CEOs", *Journal of Finance*, Vol. 62 No. 2, pp. 917-949.
- Hartzell, J.C. and Starks, L.T. (2003), "Institutional investors and executive compensation", *The Journal of Finance*, Vol. 58 No. 6, pp. 2351-2374.
- Haveman, H.A. (1993), "Follow the leader, Mimetic isomorphism and entry into new markets", *Administrative Science Quarterly*, Vol. 38 No. 4, pp. 593-627.

- Hayward, M. and Hambrick, D. (1997), "Explaining the premiums paid for large acquisitions: evidence of CEO hubris", *Administrative Science Quarterly*, Vol. 42 No. 1, pp. 103-127.
- Henderson, A.D. and Fredrickson, J.W. (2001), "Top management team coordination needs and the CEO pay gap, a competitive test of economic and behavioral views", *Academy of Management Journal*, Vol. 44 No. 1, pp. 96-117.
- Heyden, M.L., Oehmichen, J., Nichting, S. and Volberda, H.W. (2015), "Board background heterogeneity and exploration-exploitation: the role of the institutionally adopted board model", *Global Strategy Journal*, Vol. 5 No. 2, pp. 154-176.
- Hofstede, G. (2011), "Dimensionalizing cultures: the Hofstede model in context", *Online Readings in Psychology and Culture*, Vol. 2 No. 1, pp. 1-26, available at: <https://doi.org/10.9707/2307-0919.1014>
- Jemison, D.B. and Sitkin, S.B. (1986), "Corporate acquisitions. A process perspective", *Academy of Management Review*, Vol. 11 No. 1, pp. 145-163.
- Kakebeeke, P. and Couwenbergh, P. (2015), "Opmerkelijke loonkloof tussen de topman en zijn cfo", available at: <http://fd.nl/ondernemen/1144036/opmerkelijke-loonkloof-tussen-aex-topman-en-zijn-cfo> (accessed May 11, 2016).
- Kale, J., Reis, E. and Venkateswaran, A. (2014), "Pay inequalities and managerial turnover", *Journal of Empirical Finance*, Vol. 27, pp. 31-39.
- Lazear, E.P. and Rosen, S. (1981), "Rank-order tournaments as optimum labor contracts", *Journal of Political Economy*, Vol. 89 No. 5, pp. 841-864.
- Lehn, K. and Zhao, M. (2006), "CEO turnover after acquisitions: are bad bidders fired?", *Journal of Finance*, Vol. 61 No. 4, pp. 1759-1811.
- Main, B.G.M., O'Reilly, C.A. III and Wade, J. (1993), "Top executive pay, tournament or teamwork?", *Journal of Labor Economics*, Vol. 11 No. 4, pp. 606-628.
- Malmendier, U. and Tate, G. (2005), "Does overconfidence affect corporate investment? CEO overconfidence measures revisited", *European Financial Management*, Vol. 11 No. 5, pp. 649-659.
- Manning, W.G. (1998), "The logged dependent variable, heteroscedasticity, and the retransformation problem", *Journal of Health Economics*, Vol. 17 No. 3, pp. 283-295.
- Martynova, M. and Renneboog, L. (2011), "The performance of the European market for corporate control: evidence from the 5th takeover wave", *European Financial Management Journal*, Vol. 17 No. 2, pp. 208-260.
- Mercer (2012), "Survey of M&A retention and transaction programs: retaining the right talent for deal success", available at: www.mercer.nl/content/dam/mercer/attachments/global/MandA/Mercer-Survey-of-Retention-and-Transaction-Programs.pdf (accessed May 11, 2016).
- Moschieri, C. and Campa, J.M. (2009), "The European M&A industry: a market in the process of construction", *Academy of Management Perspectives*, Vol. 23 No. 4, pp. 71-87.
- Nadolska, A. and Barkema, H.G. (2014), "Good learners: how top management teams affect the success and frequency of acquisitions", *Strategic Management Journal*, Vol. 35 No. 10, pp. 1483-1507.
- Navahandi, A. and Malekzadeh, A.R. (1988), "Acculturation in mergers and acquisitions", *Academy of Management Review*, Vol. 13 No. 1, pp. 79-90.
- Pollock, T.G., Rindova, V.P. and Maggitti, P.G. (2008), "Market watch, information and availability cascades among the media and investors in the US IPO market", *Academy of Management Journal*, Vol. 51 No. 2, pp. 335-358.
- Poutsma, E. and Braam, G. (2005), "Corporate governance and labour management in The Netherlands: getting the best of both worlds?", in Gospel, H. and Pendleton, A. (Eds), *Corporate Governance and Labour Management: International Comparison*, Oxford University Press, Oxford, pp. 148-172.
- Rajan, R.G. and Wulf, J. (2006), "The flattening firm: evidence from panel data on the changing nature of corporate hierarchies", *The Review of Economics and Statistics*, Vol. 88 No. 4, pp. 759-773.
- Ridge, J.W., Aime, F. and White, M.A. (2015), "When much more of a difference makes a difference: social comparison and tournaments in the CEO's top team", *Strategic Management Journal*, Vol. 36 No. 4, pp. 618-636.

- Rosen, S. (1992), "Contracts and the market for executives", in Wein, L. and Wijkander, H. (Eds), *Contract Economics*, Blackwell, Oxford, pp. 1-54.
- Sanders, W.G. and Hambrick, D.C. (2007), "Swinging for the fences: the effects of CEO stock options on company risk taking and performance", *Academy of Management Journal*, Vol. 50 No. 5, pp. 1055-1078.
- Saxton, T. and Dollinger, M. (2004), "Target reputation and appropriability, picking and deploying resources in acquisitions", *Journal of Management*, Vol. 30 No. 1, pp. 123-147.
- Shaw, J.D., Gupta, N. and Delery, J.E. (2002), "Pay dispersion and workforce performance: moderating effects of incentives and interdependence", *Strategic Management Journal*, Vol. 23 No. 6, pp. 491-512.
- Siegel, P.A. and Hambrick, D.C. (2005), "Pay disparities within top management groups, evidence of harmful effects on performance of high-technology firms", *Organization Science*, Vol. 16 No. 3, pp. 259-274.
- Stearns, L.B. and Allan, K.D. (1996), "Economic behavior in institutional environments: the corporate merger wave of the 1980s", *American Sociological Review*, Vol. 61 No. 4, pp. 699-718.
- Tang, J., Crossan, M. and Rowe, W.G. (2011), "Dominant CEO, deviant strategy, and extreme performance: the moderating role of a powerful board", *Journal of Management Studies*, Vol. 48 No. 7, pp. 1479-1503.
- Terza, J.V., Basu, A. and Rathouz, P.J. (2008), "Two-stage residual inclusion estimation, addressing endogeneity in health econometric modeling", *Journal of Health Economics*, Vol. 27 No. 3, pp. 531-543.
- The Economist* (2014), "Inequality in the Netherlands: a capital issue", June 28, available at: www.economist.com/news/europe/21605955-how-large-differences-wealth-have-begun-new-tax-debate-capital-issue (accessed August 23, 2016).
- The Financial Executive (2013), "CFOs holding back from investment and growth", Vol. 29 No. 8, pp. 3-4.
- The Guardian* (2016), "City's bonus culture is bad for customers, the economy and for workers", August 22, available at: www.theguardian.com/business/economics-blog/2016/aug/22/city-bonus-culture-bad-for-customers-the-economy-for-workers-neil-woodford (accessed March 15, 2018).
- Thomas, R. (2004), "Explaining the international CEO pay gap: board capture or market driven?", *Vanderbilt Law Review*, Vol. 57 No. 4, pp. 1171-1267.
- Tosi, H.L., Werner, S., Katz, J.P. and Gomez-Mejia, L.R. (2000), "How much does performance matter? A meta-analysis of CEO pay studies", *Journal of Management*, Vol. 26 No. 2, pp. 301-339.
- Wallace, M.J. Jr and Fay, C.H. (1983), *Compensation Theory and Practice*, Kent, Boston, MA.
- Wooldridge, J.M. (2002), *Econometric Analysis of Cross Section and Panel Data*, MIT Press, Cambridge, MA.
- Wright, P., Kroll, M., Krug, J.A. and Pettus, M. (2007), "Influences of top management team incentives on firm risk taking", *Strategic Management Journal*, Vol. 28 No. 1, pp. 81-89.
- Yim, S. (2013), "The acquisitiveness of youth: CEO age and acquisition behavior", *Journal of Financial Economics*, Vol. 108 No. 1, pp. 250-273.

Further reading

- Aggarwal, R.K. and Samwick, A.A. (2003), "Performance incentives within firms, the effect of managerial responsibility", *The Journal of Finance*, Vol. 58 No. 4, pp. 1613-1649.
- Bebchuk, L.K.M., Cremers and Peyer, U. (2011), "The CEO pay slice", *Journal of Financial Economics*, Vol. 102 No. 1, pp. 199-221.
- O'Reilly, C.A., Doerr, B., Caldwell, D.F. and Chatman, J.A. (2014), "Narcissistic CEOs and executive compensation", *The Leadership Quarterly*, Vol. 25 No. 2, pp. 218-231.
- Wade, J.B., O'Reilly, C.A. and Pollock, T.G. (2006), "Overpaid CEOs and underpaid managers, fairness and executive compensation", *Organization Science*, Vol. 17 No. 5, pp. 527-544.
- Wowak, A.J. and Hambrick, D.C. (2010), "A model of person-pay interaction, how executives vary in their responses to compensation arrangements", *Strategic Management Journal*, Vol. 31 No. 8, pp. 803-821.

Corresponding author

Gerwin Van der Laan can be contacted at: G.vdrlaan@tilburguniversity.edu

Table A1.
Descriptive statistics
and correlations
relating to pay
disparity, CEO pay,
and other TMT pay

	Mean	SD	(1)	(2)	(3)	(4)	(5)	(6)	(7)
(1) Log total pay disparity	12.17	1.8							
(2) Acquisition dummy	0.53	0.49	0.31*						
(3) Number of acquisitions	1.55	2.32	0.34*	0.62*					
(4) Average acquisition deal value (scaled)	0.03	0.24	0.14*	0.12*	0.18				
(5) Organic growth	0.05	0.03	-0.01	-0.05	-0.06	-0.15*			
(6) Avg. length of acq. negotiations (days)	24.75	52.27	0.19*	0.28*	0.30	0.12*	-0.08		
(7) Fraction abandoned acquisitions	0.16	0.31	0.12*	0.33*	0.19	0.08	-0.04	0.00	0.20*
(8) Fraction cross-border	0.29	0.41	0.33*	0.65*	0.49	0.16*	-0.05	0.26*	0.09
(9) Firm size	0.49	1.34	0.29*	0.24*	0.23	0.40*	-0.09	0.27*	0.07
(10) Board size	3.20	1.77	0.28*	0.26*	0.30	0.02	-0.03	0.21	0.06
(11) Profit (scaled)	0.05	0.13	0.06	0.18*	0.12	-0.00	-0.04	-0.06	0.06
(12) Earnings per share	1.2	1.37	0.03	-0.05	-0.01	0.07	-0.12*	0.08	-0.04
(13) Absolute shareholder return	0.18	0.49	0.12*	0.10*	0.01	-0.02	0.07	-0.03	0.06
(14) Herfindahl index ownership	1.01	1.29	-0.12*	-0.14*	-0.14	-0.07	0.03	-0.10	0.02
(15) Foreign ownership	0.30	0.30	0.02	-0.01	-0.03	-0.09	0.10*	-0.02	-0.02
(16) CEO turnover	0.09	0.29	0.10	-0.07	-0.08	-0.03	0.05	-0.07	0.03
(17) TMT turnover	0.36	0.77	0.18*	0.06	0.09	-0.03	0.04	0.11*	-0.02
(18) Log CEO pay	13.44	1.03	0.18*	0.15*	0.12*	-0.05	0.14*	0.09	0.18*
(19) Log other TMT pay	13.22	1.61	0.38*	0.43*	0.20*	0.08	0.25*	0.17*	0.39*

(continued)

	(8)	(9)	(10)	(11)	(12)	(13)	(14)	(15)	(16)
(1) Log total pay disparity									
(2) Acquisition dummy									
(3) Number of acquisitions									
(4) Average acquisition deal value (scaled)									
(5) Organic growth									
(6) Avg. length of acq. negotiations (days)									
(7) Fraction abandoned acquisitions									
(8) Fraction cross-border									
(9) Firm size	0.27*								
(10) Board size	0.25*	0.42							
(11) Profit (scaled)	0.12*	-0.01	0.11*						
(12) Earnings per share	0.05	0.10	0.09	0.13					
(13) Absolute shareholder return	0.06	-0.08	-0.06	0.00	-0.15*				
(14) Herfindahl index ownership	-0.116*	-0.17*	-0.26*	-0.20	-0.09	0.01			
(15) Foreign ownership	-0.07	-0.07	-0.01	-0.09	-0.18*	-0.00	-0.18*		
(16) CEO turnover	-0.09	0.04	0.18*	-0.01	0.08	-0.07	0.02	0.03	
(17) TMT_turnover	0.04	0.19	0.58*	-0.05	0.04	-0.04	-0.06	-0.01	0.33*
(18) Log CEO pay	0.28*	0.25*	0.01	0.02	-0.10	-0.08	0.06	0.01	0.05
(19) Log other TMT pay	0.45*	0.50*	0.07	0.01	0.10	-0.17	0.07	0.07	0.21*

Note: *Correlation is significant at 0.05 level (two-tailed)

Table AI.