

ASPECTS OF THE STRUCTURE OF THE
NOUN PHRASE IN MODERN GREEK

BY
MELITA STAVROU

A Thesis submitted for the degree of
Doctor of Philosophy

University of London
School of Oriental and African Studies
1983

ProQuest Number: 10672769

All rights reserved

INFORMATION TO ALL USERS

The quality of this reproduction is dependent upon the quality of the copy submitted.

In the unlikely event that the author did not send a complete manuscript and there are missing pages, these will be noted. Also, if material had to be removed, a note will indicate the deletion.



ProQuest 10672769

Published by ProQuest LLC (2017). Copyright of the Dissertation is held by the Author.

All rights reserved.

This work is protected against unauthorized copying under Title 17, United States Code
Microform Edition © ProQuest LLC.

ProQuest LLC.
789 East Eisenhower Parkway
P.O. Box 1346
Ann Arbor, MI 48106 – 1346

TO MY PARENTS

ACKNOWLEDGEMENTS

I wish to express my deep gratitude to my supervisor Dr. G.C. Horrocks, to whom I am indebted more than can be acknowledged here, for his invaluable and generous advice and comments on both the substance and manner of presentation of this thesis, as well as for his constant encouragement during the three years it took me to complete it.

It gives me great pleasure to record here my thanks to Dr. Th. Bynon and Dr. K. Mickey for their help and comments on earlier drafts of my work. I am also grateful to Prof. Dh. Theophanopoulou-Kontou who read and made useful suggestions on a first draft of the Relative Clause (A) chapter.

A word of public thanks also goes to my parents, whose support and encouragement were invaluable during the four years of my postgraduate studies.

I have to extend my thanks to Dr. A.Ph. Christidis, who read and commented on a first version of the partitive/pseudopartitive section (chapter III), as well as to Dr. I. Veloudis, Miss Chr. Laskaratou and Miss Z. Farinou for many conversations I had with them and for their useful criticism and comments on many of my examples.

I owe an altogether special debt to my husband, Nikos, for his patience and much-needed assistance (even... linguistic) during the three years of my absence in England, but, mainly, while the thesis was actually being completed during this last year.

Finally, I gratefully acknowledge the support of the 'Alexander S. Onassis' Public Benefit Foundation, which made possible my studies in England during the years 1979-1982, and thus enabled my work to get under way.

ASPECTS OF THE STRUCTURE OF THE NOUN PHRASE
IN MODERN GREEK

ABSTRACT

This thesis attempts to provide an account of certain aspects of the Noun Phrase in Modern Greek. It is composed of four chapters. In the first chapter (I) the formal apparatus and the devices used, which are those of the recent formulation of the Generalized Phrase Structure Grammar (GPSG), are presented. In the second chapter (II) phrase structure rules for the items occupying the specifier positions - i.e. prenominal modifiers - are proposed. In particular, the distribution and interaction of articles and expressions of quantification and degree are discussed. Then, the internal structure of Adjective Phrases marked as + or -Q is considered. Finally, the position of adjectives within the noun phrase is examined. It is argued that adjectives appearing after the noun in both definite and indefinite NPs are, indeed, complements, whereas in prehead position they are (attributive) specifiers, but in either case they are restrictive modifiers, therefore they belong to N'. As (posthead) complements they are instances of the phenomenon of so-called 'apposition' - namely they are [α case] complements. In the Appendix the phenomenon of restrictive nominal apposition is viewed with regard to both English and Modern Greek. Thus, while in English apposition falls under the description of attributive (prenominal) modification, as Burton has effectively shown, in modern Greek it is rather a descriptive term for nominal complementation. It is only the 'pseudopartitive' construction in MG that is referred to as 'apposition' and exhibits a case of premodification, in addition to a case of [α case] complementation related to the same construction. It is this

structural ambiguity of the 'pseudopartitive' construction that is pointed out in chapter three (III), and rules for the two structures corresponding to the two interpretations of this construction - an amount and a consistive one - are proposed. In this chapter the partitive construction and a type of nominal complement marked as [+nominative] are also examined. In the fourth (IV) chapter I concentrate upon adjectival and nominal ('Free') relatives. Dependencies into subject, object, possessive genitive and object of preposition position - in both *wh*- and *pu* adjectival and nominal relatives - are taken care of by two general slash elimination metarules (SEM I, SEM II) that are introduced in chapter I. With regard to nominal relatives, it is shown that if they occupy an argument position within the main clause they are headed, the *wh*-phrase introducing them being their head; nominal relatives that occupy a non-argument position - such as a topic position - are headless, the *wh*-phrase being in a position parallel to that occupied by the *wh*-phrase (pronoun) in ordinary adjectival relatives.

CONTENTS

| | page |
|--|------|
| Acknowledgements | 3 |
| Abstract | 4 |
| Table of contents | 6 |
| Abbreviations and Symbols | 12 |
| I. GENERAL INTRODUCTION | 14 |
| NOTES | 37 |
| II. NP SPECIFIERS | |
| 0. Introduction | 40 |
| 1. Jackendoff's NP specifier system | 40 |
| 1.1 Categories participating in the Specifier System of the NP in Modern Greek | 43 |
| 2. PS Rules for the Specifiers of the NP | 44 |
| 2.1 Specifiers of Nouns | 44 |
| 2.1.1 'QP' is a redundant node | 45 |
| 2.1.2 The two specifier positions of the NP: N'' and N' | 47 |
| 2.2 The internal structure of the AP | 50 |
| 2.2.1 What are Degree Words ? | 51 |
| 2.2.2 The basic structure of non-quantifi- cational Adjective Phrases | 58 |
| 2.2.2.1 Non-comparative quantificational adverbs as specifiers of adjectives | 60 |
| 2.2.2.2 Recursion and the comparative adverbs <i>pyo/perisotero</i> | 71 |
| 2.2.3 The structure of AP marked as [+Q] | 79 |
| 2.2.4 Summary | 85 |
| 2.3 Measure Phrases | 92 |
| 2.3.1 Measure Phrases in Jackendoff's X'-Syntax | 92 |
| 2.3.2 Measure Phrases as prehead modifiers of the modern Greek NP | 93 |
| 2.3.2.1 The position of Measure Phrases in the NP | 94 |
| 2.3.3 The position of Measure Phrases in Adjective Phrases | 102 |

| | page |
|---|------|
| 2.3.3.1 Measure phrases in the expansion of <i>toso</i> and <i>pyo</i> | 105 |
| 2.3.4 Summary | 109 |
| 3. Adjectives as modifiers of N' (A discussion on the position of prenominal and postnominal adjectives) | 110 |
| 3.1 A short history of the syntactic account of prenominal adjectives | 110 |
| 3.1.1 The derivation of prenominal adjectives in the (early) trans- formational framework | 110 |
| 3.1.1.1 Bolinger's counterevidence | 112 |
| 3.1.2 Prenominal A as N'' specifiers within (Jackendoff's) X' Syntax | 117 |
| 3.1.3 Two 'problems' | 118 |
| 3.1.3.1 Adjectival modification of proper names | 118 |
| 3.1.3.2 The restrictive/non-restrictive ambiguity of prenominal adjectives | 120 |
| 3.1.3.3 Summary | 121 |
| 3.2 Adjectival modification in MG | 121 |
| 3.2.1 The problem: what are adjectival strings occurring after the head noun? | 122 |
| 3.2.2 The position of prenominal adjectives | 123 |
| 3.2.3 Posthead adjectives are complements of N' | 127 |
| 3.2.3.1 Justification for our claim | 128 |
| 3.2.3.2 Two questions | 134 |
| 3.2.3.2.1 The relationship between restrictive relatives and adjectival complements | 134 |
| 3.2.3.2.2 The position of adjectival comple- ments within the NP | 135 |
| 3.2.4 A potential problem of our analysis | 136 |
| 3.2.5 A consequence of our analysis of adjectives | 137 |
| 3.2.6 Definite (posthead) APs | 139 |
| 3.2.6.1 Evidence for the complement status of postnominal adjectives | 140 |

| | page |
|--|------|
| 3.2.6.2 The nature of the definite adjectival complements | 145 |
| 3.2.7 Summary | 148 |

APPENDIX

NOMINAL APPPOSITION

| | |
|---|-----|
| 0. Introduction | 152 |
| 1. The appositive construction in English | 152 |
| 1.1 The traditional derivation of appositive NPs | 154 |
| 1.2 Burton's account of appositive NPs | 154 |
| 2. The appositive construction in traditional MG Grammar | 157 |
| 2.1 A criticism: our analysis | 159 |
| NOTES | 165 |

III. SOME NP COMPLEMENTS

| | |
|--|-----|
| 0. Introduction (some general remarks on the position of NP complements) | 180 |
| A. A CONSTRUCTION WITH A DOUBLE MEANING: THE SO-CALLED PSEUDOPARTITIVE AND NOUN-COMPLEMENT (CONSISTIVE) STRUCTURES | |
| 0. Introduction | 187 |
| 1. The Pseudopartitive construction in English | 188 |
| 1.1 Properties of the Pseudopartitive construction | 189 |
| 1.2 The Pseudopartitive as an ambiguous construction | 189 |
| 1.3 Summary | 192 |
| 2. A type of ambiguous appositive complement in MG | 193 |
| 2.1 Some more notes on the 'pseudoparti- tive' construction | 194 |
| 2.1.1 Measure or unit nouns as 'classifiers' | 195 |
| 2.2 Evidence for a second structure | 200 |

| | page |
|---|---|
| 3. | The so-called 'consistive' complement 202 |
| 3.1 | A note on lexical subcategorization concerning consistive complements 204 |
| 3.2 | Some additional evidence for the consistive reading 207 |
| 3.3 | Remaining problems 208 |
| B. THE PARTITIVE CONSTRUCTION | |
| 1. | Partitive NPs in English 211 |
| 1.1 | The syntactic and semantic function of the partitive phrase 211 |
| 1.2 | Properties of the partitive phrase 213 |
| 1.3 | Partitive versus Pseudopartitive construction 219 |
| 1.3.1 | Is the partitive construction fundamentally different from the so-called noun complement (constive)one? 224 |
| 2. | Partitive phrases in Modern Greek; properties of the Partitive Construction 225 |
| 2.1 | Mobility of the partitive phrase 230 |
| 2.1.1 | Restrictive Relatives in the partitive construction 233 |
| 2.1.1.1 | Conclusion 236 |
| 2.2 | Verb agreement in partitives 237 |
| 2.3 | Partitive complements with a clitic pronoun 239 |
| 2.4 | Rules for partitives 243 |
| 2.4.1 | A concluding note 245 |
| C. A NOMINATIVE (INDECLINABLE) COMPLEMENT | |
| 0. | Introduction 246 |
| 0.1 | The data 246 |
| 1. | The structure of [+nom] complements 247 |
| 1.1 | More evidence for our analysis 250 |
| 2. | Summary 252 |
| | NOTES 253 |

| | page |
|---|------|
| IV. RELATIVE CLAUSES | |
| A. ADJECTIVAL RELATIVES | |
| 0. Introduction | 260 |
| 1. Differences between restrictives and appositives | 261 |
| 1.1 Appositives belong to a separate intonation group | 263 |
| 1.2 Formal correlates of the differences between restrictives and appositives | 264 |
| 1.2.1 The object clitic pronoun in appositives | 269 |
| 1.2.2 Bache and Jakobsen's distinction between restrictives/non restrictives | 272 |
| 1.2.2.1 Summary | 279 |
| 1.2.3 A further distinction between restrictives and appositives | 280 |
| 1.2.4 A difference in relativizeability between English and Modern Greek | 284 |
| 2. The internal structure of R Relatives in MG | 285 |
| 2.1 Sentential categories of MG | 285 |
| 2.1.1 There are two types of RCs in MG | 287 |
| 2.2 WH Relatives with object dependencies | 288 |
| 2.3 WH Relatives with subject dependencies | 289 |
| 2.4 WH Relatives with PP dependency | 290 |
| 2.4.1 'Complex' Adverb Phrases and WH Relatives | 292 |
| 2.4.2 Some clarificatory notes | 296 |
| 2.5 WH Relatives with a possessive genitive dependency | 301 |
| 2.6 Evidence provided by cases of conjoined RCs | 304 |
| 2.6.1 Summary | 311 |
| 3. Non-WH restrictive relatives | 313 |
| 3.1 <i>Pu</i> is a complementizer | 313 |
| 3.2 <i>Pu</i> -RCs with subject dependencies | 315 |
| 3.3 <i>Pu</i> -relatives with a direct object dependency | 316 |

| | page |
|-------|--|
| 3.4 | <i>Pu</i> -relatives with a possessive genitive dependency 318 |
| 3.5 | <i>Pu</i> -relatives with an indirect object dependency 324 |
| 3.5.1 | Some general remarks 325 |
| 3.5.2 | A syntactic account of 'indirect object' relatives 328 |
| 3.6 | Conjoined DO and IO RCs 331 |
| 3.6.1 | A note on some 'idiosyncratic' cases of coordination 333 |
| 3.7 | <i>Pu</i> -relative clauses with a PP dependency 336 |
| 3.7.1 | General remarks 336 |
| 3.7.2 | An account of 'PP' dependencies in <i>pu</i> -relatives 338 |
| 3.7.3 | 'Complex' Adverb Phrases and <i>pu</i> -relatives 343 |
| 3.7.4 | Summary 346 |
| 3.8 | The omission of the PP in <i>pu</i> -relative clauses 347 |
| 3.9 | Clitics in <i>pu</i> -RCs and the 'Accessibility Hierarchy' 351 |
| 4. | The structural position of restrictives and appositives 354 |
| 4.1 | The structural position of restrictives and appositives in Jackendoff's Grammar 354 |
| 4.2 | The position of appositives 355 |
| 4.3 | Summary 357 |

B. 'FREE' (NOMINAL) RELATIVES
(An analysis)

| | |
|-----|--|
| 1. | General remarks 359 |
| 2. | The nominal character of 'nominal' relative clauses 361 |
| 2.1 | Nominal relatives as 'free' relatives 362 |
| 2.2 | Further evidence for the nominal status of 'free' relatives 363 |
| 3. | A syntactic analysis of nominal relative clauses 365 |
| 3.1 | Nominal relatives in argument positions 365 |
| 3.2 | Nominal relatives in non-argument position 379 |
| 4. | Summary 383 |
| | NOTES 385 |
| | BIBLIOGRAPHY AND REFERENCES 397 |

ABBREVIATIONS AND SYMBOLS

The following abbreviations and symbols are often used in this thesis:

- AH : Accessibility Hierarchy
- Akm. @ L. : Akmajian, A. @ Lehrer, A.
- Al.-And. @ D. : Allwood, J., Andersson, L.-G. @ Dahl, Ö.
- B. @ J. : Bache, C. @ Jakobsen, L.-K.
- Bol. : Bolinger, D.
- Br. @ Gr. : Bresnan, J. @ Grimshaw, J.
- G.-K.-P. @ S. : Gazdar, G., Klein, E., Pullum, G. @
Sag, I.
- G. @ P. : Gazdar, G. @ Pullum, G.
- H. @ G. : Horrocks, G. @ Gazdar, G.
- Jack. : Jackendoff, R.
- K. @ C. : Keenan, E. @ Comrie, B.
- Q : Question or Quantifier
- SEM (I @ II) : Slash Elimination Metarule (I @ II)
- v. or vs : versus
- "...." : for quoted original extracts
- '....' : for terms, standard expressions, definitions, sayings, unaccompanied by a reference.
- : : indicates page(s) in references; when a reference is made to a page of the thesis p will be used. P is also used in ch. II, where frequent references are made only to page of Bolinger's article.
- PRO or [e] is used invariably to indicate a lexically empty node, though [e], as more convenient, is used in rules (and in corresponding tree-diagrams, if any).
pro (or PRO) as a feature of certain NP nodes (ch.IV) designates 'pronoun'/'pronominal'.

- The prime notation X^n is strictly used in the rules and the corresponding tree-diagrams of MG examples, but I shall also be loosely using the more 'descriptive' notation XP in the (main) text. In the references the original notation is maintained.
- The 'node admissibility condition' notation ($X[YZ]$) rather than the 'rewriting' notation ($X \rightarrow YZ$) will be used, apart from in original quotations and references, where the latter may have been used. It must be recalled that simple PS (and not ID) rules are used throughout, apart from in the Introduction, where ID rules are used as inputs to metarules for the reason that all the (meta)rules presented there are given in the form they have in the articles cited. Similarly, in chapter IV, ID rules are used in all the versions of the two SEMs, because the latter here are given as an 'extension' of the corresponding metarules of the Introduction.
- When reference is made to our grammar of bar levels, the phrase 'complement of X^n ' is used, where X^n is meant as the *sister* of the complement. But when I refer or quote from Jackendoff's (1977) ' X^n complement - or complement in X^n -' is used, where now X^n also designates the *mother* of the complement.
- Greek examples are generally followed by a gloss (beginning with a small letter) followed by an English translation (beginning with a capital letter). But when the greek examples get an exact English translation, the gloss is omitted. Or, if the gloss is very close to the translation the latter is omitted. In a pair of similar Greek examples a single translation is given.
- Recursiveness of A' and N' is designated in trees only when this is relevant to the point made with regard to a tree.

I. GENERAL INTRODUCTION

0. In the coming pages I shall present the formal apparatus which will be used throughout the present thesis.

The framework in terms of which certain aspects of the modern Greek noun phrase will be accounted for is that of Generalized Phrase Structure Grammar (GPSG) as recently formulated by G. Gazdar and G. Pullum (1982) and Gazdar, Klein, Pullum, Sag (1982). However, insights of previous works on CF-PSG, as those presented by Gazdar (1980, 1981), will also be assumed. I believe that the best way to check or demonstrate the advantages or/and disadvantages of a new theory is to apply it to a given language and evaluate the results of this application.

1. GPSG is claimed to be a variant of context free phrase structure grammar, a "type of generative grammar that exploits several of the resources of transformational grammars, but which, crucially, does not employ either transformations or coindexing devices, and which induces only a single level of structural description" (G. @ P. 1982:1). Here I shall not deal with every detail of the Grammar, for which see G. @ P. (1982) and G.-K.-P. @ S. (1982). I shall only present the particular mechanisms and devices that will be used in this thesis.

Thus, in the works cited above a crucial use is made of what is called 'Immediate dominance (ID)/Linear precedence (LP) format'. This allows for a large set of *PS rules*¹ to be collapsed into a much smaller set of rules which express the necessary generalization about subcategorization and order. For immediate dominance the following type of statement is used:

$$A \rightarrow B, C, D$$

This does not define a set of PS rules, because it says nothing about the linear order of B, C and D under A. It only "allows the induced grammar to contain a set of PS rules which permit an A to immediately and exhaustively dominate a B, a C and a D" (G.@ P.1982:19). Linear precedence is stipulated by the LP statement which introduces the asymmetric, transitive relation <

$A < B$,

read as "if A and B both appear on the right hand side of a PS rule then A precedes B" (ibid. p. 19). $A < B < C$ is an abbreviation for $A < B$ and $B < C$. Thus, a grammar is defined as a set of ID rules and a set of LP rules. "The *phrase structure grammar* induced by such a grammar definition consists of all the phrase structure rules (which express dominance and precedence relations simultaneously) that are consistent with *some* ID rules and *all* LP rules. This 'ID/LP format' proposal presupposes that grammars have a particular property... exhaustive constant partial ordering (ECPO) - i.e. the LP rules (partially) linearizing the right hand side of ID rules expanding any one category will also linearize in the same way the right hand side of the ID rules expanding all other categories" (Horrocks 1983:96)². It should be stressed, however, that *the phrase structure rules currently used display both dominance and precedence relations simultaneously*. The PSG itself is just a list of rules, fully specified, that does not express any generalizations at all. It is only in the 'metagrammar' (cf. G.@ P.1982:19) that dominance and precedence are separated. Thus, I shall be using conventional PS rules throughout and I shall make use of LP rules mainly in chapter II, for the reasons that will become clear there. ID rules will be used in the metarules of chapter IV.

2. Concerning now lexical subcategorization, it is demonstrated (G. @ P. 1982, section 5) that facts about meaning cannot account for all the restrictions on the contexts of occurrence of lexical items. Some, at least, of these have to be specified by the grammar instead of being filtered out semantically - namely those that fall traditionally under the heading of strict subcategorization. The device the present theory employs for subcategorization is as follows: Each context free rule (strictly ID rule, see p. 17) is associated with an identifying integer. Thus, suppose a rule i "introduces a lexical category C , and only a proper subset of lexical items of category C can appear under C in the environment created by the syntactic component of rule i " (G. @ P. 1982:16). This subset is represented $C[i]$ in a rule like:

< i ; $K \dots C[i] \dots$ >

For simplicity, rules will be written in the form:

< i ; $K \rightarrow \dots C \dots$ >

but this must be always considered as an abbreviation - by-convention of the first rule; i.e. "whenever a syntactic rule mentions a lexical category (that is, N, V etc.), ... the rule number appears as one of the features on the lexical category" (ibid.). Therefore, given a rule like

< 4; $VP \rightarrow V$ >

we can stipulate in the lexicon that *disappear* belongs to the class of verb $V[4]$. Obviously *eat* does not belong to $V[4]$. Notice that this method avoids the

duplication of information in standard TG, where PS rules and the lexicon both give information about subcategorization frames. Given that NPs, too, subcategorize items as their functional arguments, we shall see in chapter III how the approach of subcategorization just outlined can also account for restrictions on contexts of occurrence of arguments of nouns.

3. *Metarules* constitute a crucial part of GPSG. These are functions from (sets of) (strictly ID) rules to (sets of) rules and are a part of the 'metagrammar'. Their work is roughly comparable to that of transformations within a TG, in that their real function is to express generalisations about subcategorization. So, instead of having to *add* in the grammar rules like those of the following pair:

- a. <15; VP → V[PAS] (PP[by])>
- b. <16; VP → V[PAS] PP[to](PP[by])>

and list them in parallel to c-d:

- c. <5; <VP → V NP>
- d. <6; VP → V NP PP[to]> ,

we get a-b by simply applying a metarule to c-d. This metarule has the following form:

$$VP \rightarrow V \ NP \ W \Rightarrow VP \rightarrow V[PAS]W \ (PP[by]),$$

and is read as: "for every rule in the grammar which permits VP to dominate V followed by NP, possibly followed by other material, there is also to be a rule in the grammar which permits a VP to dominate passive V,

followed by the other material, if any, from the original rule, followed optionally by a PP carrying the feature [by]. By convention, the rule number of the output rule is set identical to that of the input rule, and any features mentioned on categories in the input rule are retained on those categories in the output rule, unless the metarule itself changes them" (G. @ P.1982:24). Accordingly, the rules numbered 5 and 6 above, when input to a metarule, will result in the addition to the grammar of output rules, also numbered 5 and 6 respectively, as e and f show:

- e. <5; VP → V[PAS](PP[by])>
- f. <6; VP → V[PAS] PP[to](PP[by])>

It is worth stressing the point made, that the above conventions guarantee the identity of rule numbers in c and e on the one hand and in d and f on the other; i.e. the subcategorization possibilities of V remain the same - we get the same subcategorization of V in active and passive VPs (a generalization expressed in 'deep' structure in TG). It is further stipulated that metarules apply only onto *lexical* (strictly ID) rules. We shall see the consequences of this restriction on the application of metarules (cf. "Lexical ID rules may be operated on by metarules..." (Horrocks 1983^a:1)) when we discuss unbounded dependencies below.

4. GPSG makes use of a highly elaborated system of features. The relevant details as far as MG NP structure is concerned will be presented in the sections concerned. Here I shall simply outline the kinds of features which can appear on node labels and the mechanism(s) that account for their distribution. First of

all, a clarification must be made regarding node labeling. Only fully specified categories appear as node labels (G. @ P. 1982:5); in other words the traditional categories (called by Jackendoff 'major/minor lexical categories' (1977, section 3)) N, V, A, P, Art, Deg, Q³ and their phrasal projections, together with complete and consistent combinations of morpho-syntactic features. Sentential categories can, thus, label a node (such as R(egative), Q(uestion) etc.), as these are taken to be projections of V (cf. IV 2.1)⁴.

In general I shall assume the basic feature system suggested by Chomsky (1970). This system is based on the features N and V. The following table illustrates the distribution of these features over the major categories N, V, A, P (taken from G. @ P. 1982:2):

| | [+N] | [-N] |
|------|------|------|
| [+V] | A | V |
| [-V] | N | P |

Thus, the above two features "group N, V, A, and P into natural classes" (ibid). This gets even more importance, because it "enables us to refer to the class of all nouns and all prepositions simply by writing [-V]" (ibid.p.3). We shall make crucial use of this remark in chapter IV.

However, I shall also assume familiarity with the amplified system of Jackendoff's (1977:33):

| | Subj | Obj | Comp | Det |
|-------------|------|-----|------|-----|
| Verb | + | + | + | |
| Modal | + | + | - | |
| Preposition | - | + | + | |
| Particle | - | + | - | |
| Noun | + | - | + | - |
| Article | + | - | - | + |
| Quantifier | + | - | - | - |
| Adjective | - | - | + | |
| Degree | - | - | - | + |
| Adverb | - | - | - | - |

The relevance of these features will become apparent in chapter II.

4a. The regular and predictable distribution of features within a phrase (essentially phenomena that fall under 'agreement') constitutes an essential part of the grammar employed here. There are three principles ('conventions') that take care of the distribution of features on PS rules (strictly on *ID* rules). First, the Head Feature Convention (HFC) states in effect that the head⁵ of a phrase must agree with its mother in all the relevant syntactic features. Such a statement presupposes a detailed definition of the head. In most versions of X-bar syntax the following general rule is used to define the 'head' of a phrase:

$$\begin{array}{c}
 \begin{array}{c} m \\ [\alpha V] \\ [\beta N] \end{array} \rightarrow \dots \dots \begin{array}{c} n \\ [\alpha V] \\ [\beta N] \end{array} \dots \dots ,
 \end{array}$$

where $n \leq m$ (or sometimes $n < m$) and $n[\alpha V \beta N]$ is the

head of $m[\alpha V \ \beta N]$.

Furthermore, 'head' is defined as the minimal such category, in the sense of bar level. Thus, in an X'' the head will be an X'' , X' or X immediately dominated by X'' , except that "if there is no such category, or if there is not a unique one with fewest bars, then there is no head" (G. & P. 1982:29). Given the above definition of 'head' and the basic property of HFC, the latter is formally expressed as:

"In a rule of the form $D \rightarrow \dots \delta \dots$ where δ is the head of D , δ carries all the features associated with D " (Gazdar 1980:135). According to this definition, the head features of the mother category determine those of the daughter constituent which is its head. The following rules illustrate the operation of the HFC:

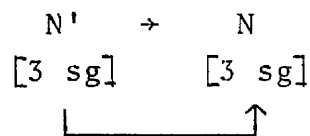
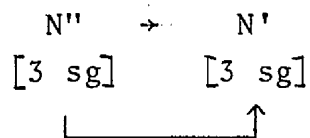

(Strictly, even major category features are handled by HFC:

$$\begin{bmatrix} +N \\ -V \\ +3 \\ +sg \end{bmatrix}'' \rightarrow H' \text{ (i.e. } \begin{bmatrix} +N \\ -V \\ +3 \\ +sg \end{bmatrix}')$$

Second, the Control Agreement Principle (CAP) is based on the assumption that "control is a relation that holds between sisters. Since sisters are, of necessity, categories introduced by the same rule, this means that

control... is a relation that can be appealed to in defining the feature instantiation principles for rules" (G. @ P.1982:31). In other words, a controlee is a function and a controller is either an argument or an argument-passing function that applies to some controller. The CAP requires the agreement features of the controller and controllee to be identical (where agreement features include person, number and gender). It is claimed that the HFC and the CAP taken together "provide the basis for a highly effective theory of agreement" (ibid. p. 36). Thus, subject-predicate agreement automatically follows from the interaction of the two "universal principles (the HFC and CAP) with the form of the syntactic and semantic rules which are motivated quite independently of the facts of agreement" (ibid. p. 33). In chapter II (section 3) the relevance of the CAP will become explicit.

Finally, the 'Foot Feature Principle' (FFP) is responsible for the distribution of what are called 'foot' features. Clearly, not all features are head features. For example, in the English sentence *These reports, the wording on the covers of which has caused so much controversy, are to be destroyed* the word *which* is not the head of the NP that contains it, but, still, it is responsible for "the *wh*-ness of that NP, and its consequent ability to appear in the position it occupies" (ibid). Foot and head features form two distinct sets with distinct properties, and just as the latter are subject to the HFC, so the former are subject to the FFP on rules, stating that a mother category must agree with all its daughter categories' foot features⁶; let us see the following rules illustrating that:

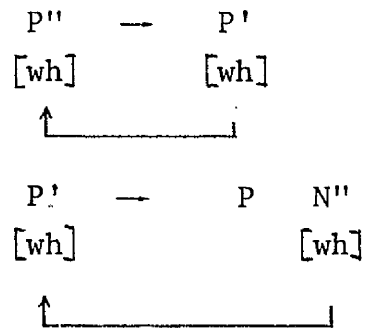

Put very plainly, "foot features are distinct from head features in that they are not necessarily a property of the head of a phrase" (Horrocks 1983^a:2).

We shall have the chance to see the application of this principle more extensively in chapter I and IV.

The agreement features we assign to various categories throughout our analysis of the modern Greek NP are captured by the FFP, the HFC or the CAP.

4b. But it will also be seen in due course that certain so-called 'terminal symbol features' are used. These "seem only to be needed for elements that are present by virtue of the type of construction involved rather than by virtue of their intrinsic lexical properties. We use them, for example, to introduce prepositions whose function is to mark case and whose semantic role is null" (G.@ P.1982:14). Such features, then, are specifically introduced in particular rules and constitute a small proper subset of the lexicon. It is the distribution of these features in 'agreement' that the *general principles* outlined above take care of. An example of such a feature concerns indirect objects. In MG verbs subcategorizing an indirect object are followed by a PP the preposition of which is always *se* ('to'). Thus the feature [+se] is introduced, "which can appear in the feature-sets of [-N-V] categories" (ibid.), and *se*

is entered in the lexicon as an item of the category P [+se]. "Any rule that has to guarantee the presence of the preposition" [se] "in a prepositional phrase can simply introduce PP [+se]" (ibid.). Thus, the HFC ensures that P in this PP will be se. In this case the PP [+se] is equivalent to case marking, specifically to a dative. E.g. *dhose sti mitera su to vivlio* ('give to your mother the book'), *dhose tis to vivlio** ('give her the book'). Cf. "... to me will contribute to the determination of meaning in exactly the same way that me would contribute" (ibid.). Other lexical items that are used as terminal symbol features are those introducing certain complementizing particles (like *pu*, *oti* etc.), the comparatives *apo*, *para*, as well as the connective words *ke* ('and') *i* ('or') *ala* ('but') in coordinate constructions (see below). Consequently, terminal symbol features are restricted "to the names of words having interpretations as logical constants. In the present context, a logical constant is a word that always denotes the same thing, no matter what facts about the world are assumed" (ibid.). For example, the 'meaningless' case-marking prepositions denote an identity function on NP meanings.

Finally, I shall also make use of features referring to morphological properties of the items involved - such as case-markings (e.g. [+gen]), the [+sup] and [+comp] features marking the superlative and comparative degree, respectively, of adjectives - or to intrinsic lexical properties such as [+Q(quantifier)]³ for those adjectives and nouns that are quantificational. The distribution of such features is handled largely by either the HFC or the FFP (see ch. II).

*It should be noticed that in MG the genitive case is equivalent to the ancient dative, which does not exist as such.

5. What is in order next, is to present the general points concerning the apparatus that accounts for unbounded dependencies within our framework. "An unbounded dependency construction is one in which (i) a syntactic relation of some kind holds between two substructures in the construction, and (ii) the structural distance between these two substructures is not restricted in any way (e.g. by a requirement that both be substructures of the same simple clause). Historically, topicalization, relative clauses, constituent questions, free relatives and various other constructions in English have been taken to involve a dependency of this kind" (G.-K.-P. @ S. 1982:8). Such constructions are thought of as consisting of three parts, the *top*, which introduces the dependency, the *middle*, which is the domain of structure introduced by the top, and the bottom is the substructure where the dependency ends or is eliminated⁷. We shall see briefly which principles govern these three parts. Unbounded dependencies are in general introduced by a rule of the form: $\alpha \rightarrow \beta \quad \alpha/\beta$, where α/β (read ' α slash β ') is thought of as an α with a β missing..." a constituent of category α/β will be a constituent of category α which has (at least) a hole in it where one would expect to find a constituent of category β " (G.-K.-P. @ S. 1982:8). For example an S/NP is a sentence which is lacking a noun phrase. What is crucial for the treatment of the 'middle' is the feature SLASH which is a foot feature whose distribution is accounted for by the FFP. Let us consider the following tree:

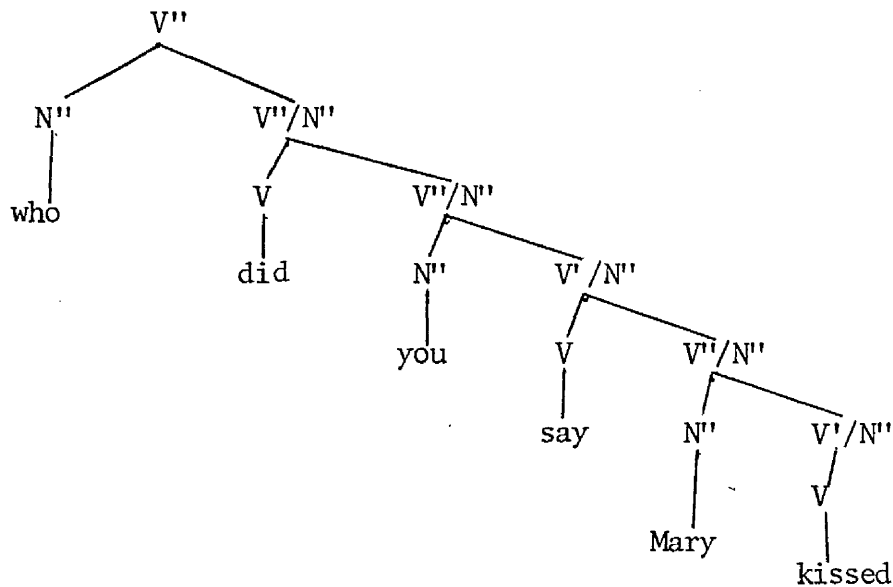

As mentioned above, the general rule schema introducing unbounded dependency constructions is $\alpha \rightarrow \beta \quad \alpha/\beta$ instantiated here as $V'' \rightarrow N'' \quad V''/N''$. All the rules expanding the 'middle' come from a principle of free instantiation of foot features on daughters (including therefore slash features) and the FFP. For example:

- | | | |
|---|---|---|
| <ol style="list-style-type: none"> 1) $V'' \rightarrow N''$, V' 2) $V'' \rightarrow N''$, V'/N'' 3) $V''/N'' \rightarrow N''$, V'/N''(FFP) | } | Free instantiation of V's slash feature. |
|---|---|---|

Cf. also "A set of rules for carrying this 'slash' information down a tree is provided by a principle of free instantiation of slash features on daughter constituents in ID rules and the Foot Feature Principle which requires the copying of these onto mothers" (Horrocks 1983^a:2). We thus get a set of 'derived' rules from the principle of free instantiation of slash features on daughters, and the FFP which copies these onto mothers. Citing G.-K.-P. @ S. (1982:10)"the generalizations

that the FFP imposes are these: (i) at least one, but possibly more than one, daughter has its slash feature instantiated in a manner identical to the instantiation on the mother, and (ii) no daughter gets its slash feature instantiated in a manner distinct from the instantiation on the mother". Coming next to the treatment of the 'bottom', this is taken care of in MG by two slash elimination (termination) metarules. The first SEM is labelled I and runs as follows:

SEM I: $\alpha \rightarrow W, \beta \Rightarrow \alpha/\beta \rightarrow W$

This metarule says that a rule which introduces a lexical head W and its complement β has a counterpart in which β is missing, "but where the mother has the category of the daughter assigned to be the value of its SLASH feature" (G.& P. 1982:11). Now, we must recall that metarules apply only to lexical PS (strictly ID) rules (p. 5). Therefore, the above SEM I will give rules that permit gaps only where W is lexical. (In MG W must also be V , as we shall see later). For example:

$V' \rightarrow V, N'' \Rightarrow V'/N'' \rightarrow V$

yields a rule which permits a transitive verb to lack its object.

However, given the above metarule, subject dependencies as those illustrated in sentences like:

1. Who did you say came ?
2. Who do you think phoned ?

cannot be accounted for, because $V'' \rightarrow N''$, V' is *not* a

lexical (ID) rule (both categories on the right of the arrow are phrasal); consequently, there can be no dependencies into subject position as things stand. If there are to be subject dependencies, subject NPs must also be governed by a lexical head. In the following trees they are not:

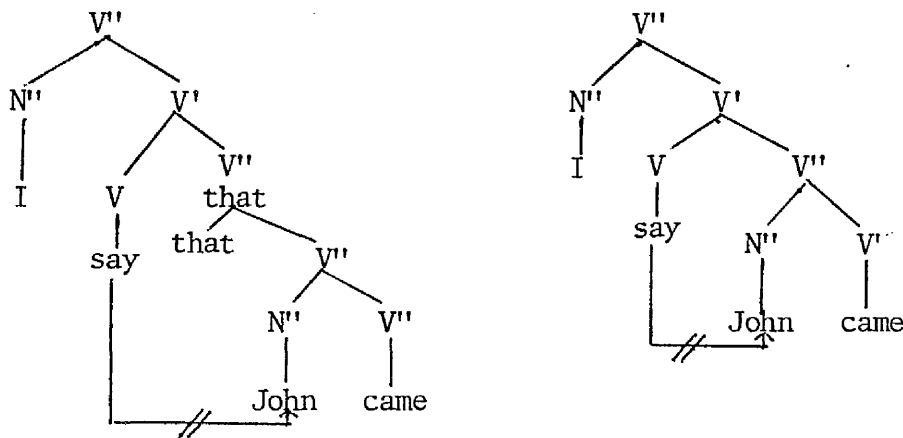

Clearly *say* in the above trees does not (lexically) govern the subject of the subordinate clause, therefore SEM I cannot apply. Nevertheless, we can 'liberate' the contents of V''(S) (i.e. N'' and V'') into the V' that contains the V subcategorized for V''(S)⁸ - then, the subject NP will be governed by V and can therefore be 'empty'. Consider the following metarule:

$$V' \rightarrow V, V''(S) \Rightarrow V'/N'' \rightarrow V, V'$$

This amounts to the slash elimination metarule Ia, stated as:

$$\text{SEM Ia } \alpha \rightarrow W, \beta \Rightarrow \alpha/I \rightarrow W, J$$

where $\beta \rightarrow I, J$ (e.g. $V'' \rightarrow N'', V'$) is a non-lexical ID rule (G.-K.-P. @ S. 1982:19).

The following tree demonstrates the effect of the SEM Ia.

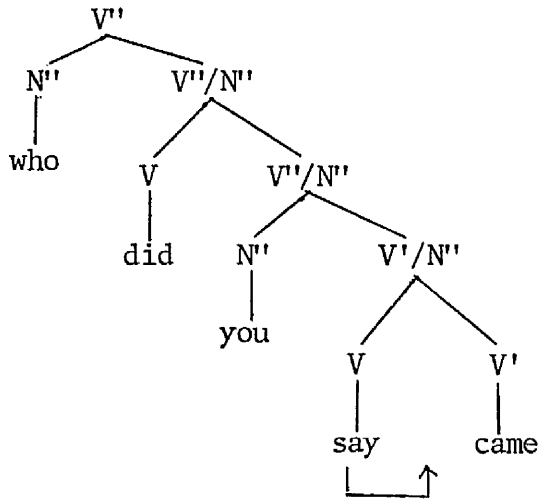

say in the above tree *does* govern the subject of the subordinate clause, therefore the latter can be 'missing'. Under this analysis, it is easy to see why the complementizer is absent in subject dependencies (the **that*-e filter of Chomsky's) and that the result of a subject dependency is a 'bare' V', not a V''/N''. From this it follows that the *who* etc. is the subject NP in simple cases like

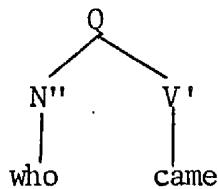

It also follows that subject and object dependencies in English do not conjoin (see below), since they belong to different categories (V' and V''/N'' respectively).

To summarize so far, we have said that all gaps must be governed by a lexical head, due to the restriction on the operation of metarules that they operate only on

lexical (strictly ID) rules. The two slash elimination (termination) metarules labelled I and Ia 'eliminate' the 'slash' category by yielding a 'gap' - namely nothing at all.

5a. We can now turn to the consequences of such a treatment on corresponding modern greek examples with a subject dependency as in 3

3. Pyos ipes pos irthe ?
who said-you that came ?⁹

It is important to recall here that in MG there are 'flat' - i.e. VP-less sentences - (cf. Horrocks 1983:99-100), as well as NP+VP structures. Because of the LP rule (see p. 15) $H < \alpha < V''$, the subject will follow the head (as well as being governed by it (ibid. p. 100)); since in these flat-S the subject position is governed by V it can be empty without difficulty, cf.:

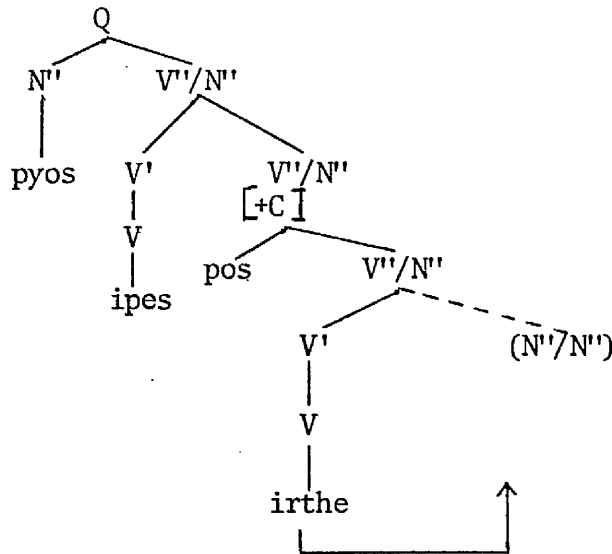

Thus, the complementizer is present and such constructions

with a subject dependency can be conjoined with others with an object dependency (see IV 2.6 and IV 3.6).

Consequently, in the tree-diagrams I shall draw (especially in ch. IV), I shall assume flat sentence structure (i.e. lacking VP)¹⁰ when the subject follows the V (and also when there is no overt subject NP). I also assume that sentences with preverbal subjects have NP-VP structure. Subject dependencies are exclusively into subject positions in 'flat' sentences. Along these lines we can explain why Greek seems to violate the **that*-e constraint - the subject position is governed by V and so accessible to SEM I. The complementizer does not stand in the way of government as it does in English.

5b. As it stands, metarule I cannot account for certain cases that as we shall see in detail in chapter IV 3 contain a resumptive pronoun¹¹, where a 'gap' - nothing at all - might otherwise be expected. In the light of such examples, it appears that in addition to the SEM I (where W=V), we further need a metarule that will 'eliminate' slash categories, *not* by introducing a gap, but by introducing a *pronoun*. This rule is called SEM II and is stated as follows:

$$\text{SEM II} \quad \alpha \rightarrow W, \begin{matrix} \beta \\ [\text{pro}] \end{matrix} \Rightarrow \alpha/\beta \rightarrow W, \begin{matrix} \beta \\ [\text{pro}] \end{matrix},$$

where $\beta = N''$ and $W = \{A, \text{Adv}, \text{NP}\}$; we shall discuss the values that W can take in particular cases in chapter IV. Here we can, however, stress that the output of SEM II is exactly a rule that already exists in the grammar, on independent grounds. I.e. there are rules that allow for clitic genitive pronouns after certain adverbs, adjectives etc. (see ch. IV). The slash elimination process simply exploits such rules.

Of course, given the two Slash Elimination Metarules, it is our task to find out what conditions the choice of slash elimination procedure - i.e. why and where we get gaps and where we get pronouns. We shall see that SEM I applies - as already mentioned - when $W=V$, SEM II otherwise. Namely, dependencies into NP positions governed by V result in *gaps* (apparent exceptions are due to clitic doubling); dependencies into NP positions governed by other lexical categories result in *pronouns*. We shall also claim that this 'distribution' follows naturally from the concept of the Accessibility Hierarchy of the relativized position, as this is developed by Keenan and Comrie. We are only left with the potential problem of the obligatory presence of the pronoun in 'special' indirect object positions (called by K. @ C. 'oblique case NPs'), which may suggest that we must allow for pronouns in V as well. But I leave the question open in the absence of sufficient and conclusive evidence.

6. In much of the present thesis we shall use extensively evidence provided by cases of coordination. Concerning coordination, I assume the views presented in Gazdar (1981) and in G.-K.-P. @ S. (1982). In general, coordination is defined by the following two definitions:

- a. "A structure rooted in α is coordinate if and only if every daughter of α is a conjunct.
- b. A category (constituent) α is a conjunct if and only if α is [+CONJ]" (G.-K.-P. @ S. 1982:2).

The feature [+CONJ] is optional and its values in English are *and*, *both*, *but*, *e* (empty string), *either*, *neither*, *nor*, *or*. It is a widely and well motivated view (see Schachter 1977) that only like categories can

be conjoined. This view, surely true and crucial for any theory of coordination, needs be further elaborated in order to capture some delicate cases. like the following:

4. She walked slowly (Adv) and with care (PP)
5. He was long winded (A) and a bully (NP)

How can an Adv be conjoined to a PP, or an A to an NP ? And what category is the 'mother' of the conjuncts in each case ? It is claimed that given the notion 'extension' of a category as defined in G. @ P. (1982)¹², it can be maintained simply that each conjunct has to be an extension of the mother.. This "does not entail that any conjunct is identical to the mother, although it is consistent with any or every conjunct being identical to the mother. Nor does it entail that any conjunct is identical to any other, although, again, it is consistent with some or all of the conjuncts being featurally identical. It does not even entail that the various conjuncts are nondistinct from each other, although it does entail that every conjunct is nondistinct from the mother" (G.-K.-P. @ S. 1982:6). In the light of this, we shall propose a similar method for treating MG examples corresponding to the English ones numbered above as 4-5 . In effect we shall account for the coordination of an A and a PP in terms of *feature composition* (see ch. II). Such an approach to certain cases means that the coordinated categories do not have *all* features in common - just that they do not conflict featurally.

7. We can make a very general outline of the recent formulation of GPSG - the basic points of which we presented above - by presenting the components of the 'metagrammar' by means of which a phrase structure grammar

should be defined (Horrocks 1983^a:1); cf.:

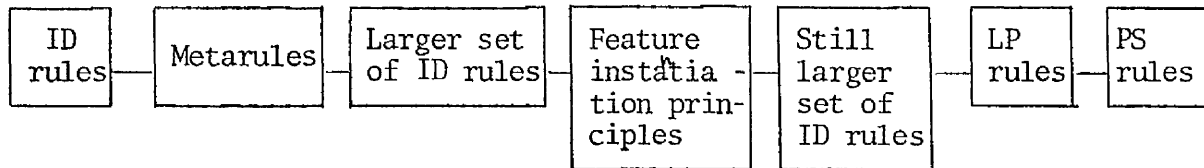

In the first 'box' we have the initial set of ID rules that "express domination relations without reference to linear order. A subset of these ('lexical' ID rules) introduce lexical heads and their complements and are equivalent to subcategorization frames" (ibid.). On these ID rules, metarules apply to give a larger set of ID rules (third 'box'). These, in turn, are "input to the set of feature instantiation principles which guarantee the proper distribution of morphosyntactic features on ID rules" (ibid.) (fourth box). Finally, LP rules (sixth 'box') map the set of instantiated ID rules (fifth 'box') into a set of PS rules (seventh 'box'). "This formalism has obvious advantages in the description of languages with relatively free phrase order where a mother constituent may dominate the same daughters but in different orders" (Horrocks 1983^a:2).

8. In this thesis a two-bar system of \bar{X} -Syntax is used instead of Jackendoff's (1977) three-bar one. The positions of the two grammars are similar, although not exactly equivalent. For example, our maximal projection of N is N'', while for Jackendoff it is N'''. The basic difference lies in the fact that our N' is recursive (see ch. II and III). This gives us extra levels where necessary. Our general phrase-structure schema for N_i and its phrasal projections:

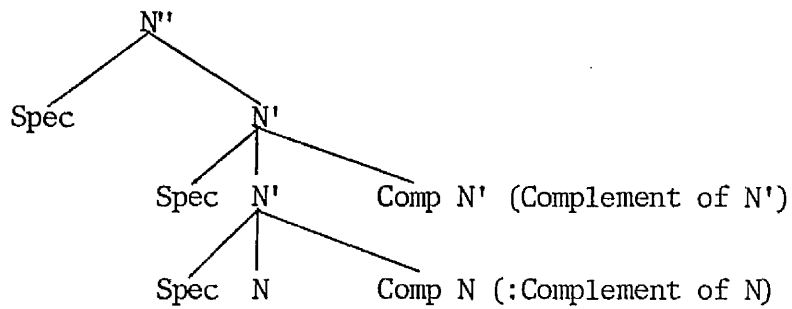

will become clear, as we discuss particular types of specifiers and complements in chapters II, III and IV. For the moment suffice it to say that the number of bar levels proposed in a particular grammar is still somewhat arbitrary¹³. The crucial thing is that it should be consistent with the available evidence concerning the attachment of the various pre/posthead constituents.

9. Before we close this Introduction, we must say a word concerning our data. This has been based on everyday speech, what has become a fashionable term 'kini dhimotiki' ('common demotic') or 'kini neoliniki' ('common MG'). The examples have been taken - for the most part - from newspapers, magazines, or literature written exclusively in the 'standard' modern Greek, or, more often, from instances of oral everyday speech. Poetic and dialectal usage is excluded, as well as cases eventually heard but clearly in divergence with the basic standard treatment of the traditional grammar books. With regard to the grammatical status of the examples cited, this has been assigned according to my own intuition and judgment, with supportive evidence from what I have heard around me. In cases of doubt, I have appealed to the intuitions of my informants, who belong to my immediate (linguistic and otherwise) environment. If this was still not conclusive, the final decision was

made on the basis of my own intuition, and the example in question was marked as *? or ??, according to the degree of disagreement involved. No systematic questionnaires were made, apart from in the case of the 'appositional' construction discussed in chapter III A. For that case I constructed a simple questionnaire in ten copies, in order to get the desired information about selectional restrictions, verb agreement and pronominalization involved in this construction. This questionnaire has not been included here, only its results were used with regard to the grammaticality/ungrammaticality of the relevant examples (cf. ch. III A).

NOTES

1. Cf. "We linearize rules, not structures, capturing generalizations by stating constituent order for whole blocks of rules at a time rather than one at a time as in standard statements of phrase structure grammars" (G @ P 1982: 19) - cf. also below.

2. There is as yet no standard view about the relationship between LP rules and bar levels. The strongest view would be that LP rules are absolute, the weakest that they vary from level to level. In any case LP rules can only order sisters - i.e. complements of the same level - as already explained.

3. In ch. II we shall claim that the category Q - as a separate category - is redundant in MG.

4. For a strict definition of syntactic categories cf. G.@ P.1982:21 : "Any feature whose feature name is CAT or CAT' is a syntactic category"; also: "A feature consists of a feature name optionally followed by one or more features or feature names. Features begin with a left bracket and end with a right bracket" (ibid.p83). According to these two definitions syntactic categories are simply a particular type of features.

5. In general, "HEAD is a feature which comprises that syntactic information held in common between phrases and their phrasal or lexical heads" (G.@ P.1982:4)

6. "However, other foot features arise on daughters in virtue of the free instantiation permitted in that mapping. And these features must appear on the mother

also. So consider a hypothetical case of an ID rule introducing 3 daughters, where neither mother nor daughters have any foot features specified. Then feature instantiation might lead to one daughter getting SLASH, another WH, and the third REFL. The FFP simply requires the mother to carry all three" (G. @ P.1982:34).

7. Cf.:... "the part of the structure in which the chain of slashed categories (i.e. the "projection path" in the sense of Fodor) comes to an end and we reach an incomplete constituent or gap" (G.-K.-P. @ S. 1982:10).

8. The motivation for this is the need for gaps to be properly governed. Nevertheless, languages vary as to where such liberation is permitted.

9. Chomsky's account of cases like *pyos ipes pos irthe* is based on the assumption that pro-drop languages, like MG, allow for free inversion of the subject and the verb, so that we may be dealing with

Pyos ipes pos irthe e ? not with
*Pyos ipes pos e irthe ?

- i.e. what would appear to be a violation of Chomsky and Lasnik's **that-e* filter is only apparent. Nevertheless, within the framework of Gazdar (1981), this explanation of the **that-e* filter can be abandoned, since it is claimed there that pro-drop languages do not obey the GLBC, thus allowing subject dependencies into preverbal as well as in postverbal positions. But given the present formulation of GPSG such an explanation is not a desirable one, because it involves a serious

weakening of the theory of metarules, which are allowed to operate only on *lexical* (ID) rules.

10. First, because, as already said, the subject can appear amongst the complements of V, second because of the LP rules $\alpha < H'$ and $H < \alpha < V''$ (see II and III) and, thirdly, because of the requirement that gaps be properly governed by a lexical head.

11. It must be stressed that such pronouns are syntactically bound - i.e. they are exactly equivalent to 'gaps' (cf. Horrocks 1983:111 note 16).

12. "An extension of a feature is like a superset. It contains everything in the original feature and may contain extra material as well". (G. & P. 1982:6). For example, all [AGR PER], [AGR [NMB 2 NMB]], [AGR PER [NMB 2 NMB]], [AGR [PER 1 PER] NMB], [AGR [PER 1 PER] [NMB 2 NMB]] [AGR [PER 1 PER] [NMB 2 NMB]] are extensions of [AGR].

13. However, two levels at least are required, one phrasal and one lexical (i.e. X'-X). It is worth pointing out that \bar{X} -Syntax is a formalization of a set of theories of phrase structure - the most well-established and used being that of Jackendoff's 1977; there is no one agreed upon theory - which can be used by any version of generative grammar that embraces the notion of constituent structure.

II. NP SPECIFIERS

0. Introduction

In this chapter we shall consider the distribution and interaction of certain 'prehead' elements that constitute the internal structure of NPs and APs such as articles and expressions of quantification and degree. The term specifier is an abbreviation for the material that precedes the head. This material varies from category to category. In NP, the specifier is associated with those categories that precede the noun, such as articles, measure phrases, adjectives. Following basically Jackendoff's (1977) argumentation for the corresponding topic in English, I shall first propose PS rules accounting for the two specifier positions of the NP-N" and N'*. Then I shall deal with the internal structure of the AP and the so-called QP - i.e. with adverbs and degree words. Next, another interesting specifier will be discussed, 'measure phrase', which is a quite idiosyncratic form of an N" specifier-parallel to other [+Q] elements, which are also N" specifiers. Finally, the position of adjectives within the NP will be considered and PS rules to account for it will be proposed.

1. Jackendoff's NP specifier system

As Jackendoff points out, specifier systems involve a finite number of lexical items and are 'riddled with idiosyncracies'. This, together with the difficulty in correlating semantic regularities with syntactic positions, are the two major problems that make the study of specifier systems a more difficult business than the study of complement systems is. Thus, "general phrase structure rules must be supported on the basis of impoverished and skewed *surface distributions*... . One way to

*"If N' " - in Jackendoff's system -" is reserved for strictly subcategorized arguments we are left with two NP specifier positions to account for, the N'" and the N" specifier" (Jackendoff 1977:104).

bring more data to bear on the problems is to exploit the *hypothesis of cross-category generalization*, and that will be a major source of evidence here" (Jack. 1977:103, the emphasis is mine). We shall see in the course of our discussion that these cross categorial generalizations are really precious evidence.

Jackendoff's account of the specifier system of the NP is based upon two central claims. First, that it performs three different semantic roles, corresponding to the three different categories participating in it: deixis, which is carried out by demonstratives, quantification, carried out by quantifiers, and measuring, carried out by numerals. Second, a specifier constraint stating that 'an NP specifier may contain at most one demonstrative, one quantifier and one numeral' explains the restrictions on the occurrence of the various specifier elements.

Now, items that, semantically, have a quantifier function are divided into two syntactic categories. One of them is assigned the category Art(icle), the other is of the category Q. The position of the first in N''' is justified on the grounds that they cannot co-occur with demonstratives - and this is due to a syntactic constraint according to which there is only one Art position available in the NP specifier - and that of the second in N'' on the grounds that they can be preceded by demonstratives. Thus, the N''' specifier position is shared by demonstratives and articles, including those that have a 'quantifier' function but cannot co-occur with demonstratives (unlike items categorized Q). The rule for N''' is accordingly:

$$N''' \rightarrow (\text{Art}''') - N''$$

Since genitive NPs appear in complementary distribution with demonstratives, the above rule is modified to include genitive NPs as well:

$$N''' \rightarrow (\{ \begin{matrix} N''' \\ \text{Art}''' \end{matrix} \}) - N''$$

The rule for N'' is

$$N'' \rightarrow (Q''') - N' - \dots$$

But since quantifiers have been divided into Articles and Qs, the above mentioned rules will generate structures with two quantifiers, such as *no many men, *all several men etc. It is the Specifier Constraint which is operative here, forbidding two (semantic) quantifiers in the same NP specifier.

Finally, these two categories of quantifiers - N'' and N''' Q - are assigned, respectively, the following feature matrices:

$$[+Subj. - Obj. - Comp. - Det], [+Subj.-Obj.,-Comp.+Det]$$

Namely, as said before, N''' quantifiers are articles, N'' quantifiers are not. These are, briefly, the basic rules for the NP specifier system proposed by Jackendoff. However, I would like to point out a difficulty. In the rule expanding N''' there is no category marked as Q, so in effect there appears just one type of Q - those in N''. Therefore, it is not clear how the Specifier Constraint restricting the occurrence of Q just to one per NP is operative. In the full expansion of the specifiers *there is only one* quantifier according to the

rules. In our analysis we shall propose a way which makes the application of the Specifier Constraint explicit (see pp. 49-50).

1.1 Categories participating in the specifier system of the NP in modern Greek

The items - more accurately the grammatical categories - that participate in the specifier system of the Greek noun phrase and with which we shall deal in this chapter are primarily adjectives and adverbs. Some clarifications are in order here. First, mainly for expository ease and clarity, I shall consider as pronouns only those which are called 'absolute' pronouns by traditional and current grammar books - i.e. pronouns that replace nouns. These are the 'personal' pronouns *egho* (I), *esi* (you), *aftos* (he, fem. *afti*, neut. *afto*). The latter is also called 'definite' ('anaphoric' or 'repetitive') and demonstrative pronoun. But since even these 'absolute' pronouns are nouns, not being featurally distinct from them, they are designated as N[+Pro]. The rest, called traditionally 'adjectival' pronouns, because they modify nouns exactly like adjectives, will be treated as ordinary adjectives - i.e. will be of the category A. For example, *Kanenas anthropos* (no man) consists of an A and a N, the same is true of *pyos anthropos* (which man), *posa vivlia* (how many books) etc. If these 'pronouns' used as adjectives are not followed by an -overt- noun, then they are still treated as adjectives, but the dominating NP node will have an empty head noun (cf. Partitives, p. 228 onwards). Second, anticipating our discussion to follow, we shall see that there is no essential need for the established QP (Q") node. So, this will be replaced by A", to which the feature [+Q] is attached,

i.e. the relevant node for QP will be A"[+Q]. Thus, the ordinary adjectives *polis* (much), *lighos* (few, little) are A"[+Q]. We shall show immediately below that the traditional indefinite pronouns like *kanenas* (no, noone), *posos*, *osos* (as much), *meriki* (plural only, some (plural)), although, in principle, they should be A"[+Q], are classified as articles, due to their distribution within the NP. The 'degree' adverbials that constitute the specifier system of APs (consequently of AdvPs as well) are *toso*, *poli*, corresponding to the adjectives [+Q] *tosos*, *polis*, and the comparative adverb *pyo*. The different features assigned to these adverbs account for the different structural positions they occupy within the AP, as well as their distributional differences.

2. PS rules for the specifiers of the NP

2.1 Specifiers of nouns

We shall start our discussion by emphasizing the condition - or rather the syntactic universal - that in simple noun phrases all specifier elements are required to agree with the head noun for all relevant syntactic features - case, number, gender, count. (Selkirk 1977). In the latest GPSG work this is taken care of by the Control Agreement Principle ("If β_i controls β_j then $AGR(\alpha_i) = AGR(\alpha_j)$ " Gazdar @ Pullum 1982:31) cf. "... our account correctly entails that agreement features are on whole phrases, not merely on lexical items, ... as it is in many languages - e.g. in French *la jeune fille intelligente* -" (ibid. p. 32). This principle is crucial for a language with a rich inflectional system, like MG, and is a prerequisite for the well-formedness of simple NPs

- cf.: 1. Poli anthropi/*polis anthropi
many men/*much men
(e.g. *polis anthropi irthan¹
much(sing) men(people) (plural) came)
2. Liyes efimeridhes/*Ligho* efimeridhes
Few newspapers/*little newspapers
3. Poli krio/*polis krio
Much cold

2.1.1 'QP'is a redundant node

We can now turn to our initial claim that QP is a 'redundant' node. 'Quantifiers' are morphologically identical to adjectives. They decline along with the noun they modify and agree with it for the features number, gender and case. Moreover, they fall into the declensional systems of adjectives²; cf.:

4. Meriki anthropi (cf. orei anthropi)
Some men
5. Poli's kafes (cf. vathis uranos)
Much coffee
6. Lighos kozmos (cf. kalos kozmos)
Few people

'Quantifiers' are parallel to ordinary adjectives with respect to the positions they hold around the noun; cf.:

*poli-ligho (πολύ-λίγο) here are the adverbs (+Q) corresponding to the adjectives *polis*, *lighos* (masc., sing., nom.).

7. {Poli} anthropi
 {Kali}

 {Many} people
 {Good}

a. Anthropi {poli}
 {kali}
people {many}
 good

8. I {poli} anthropi
 {kali}

 The {many} people
 {good}

a. *I anthropi {poli} (cf. p.121ff)
 {kali}

b. I anthropi {i poli} (cf. p.121ff)
 {i kali}

the people {the many}
 {the good}

These similarities, morphological and distributional, between traditional adjectives and quantifiers are satisfactorily represented if we label quantifiers as A(djectives) and include the feature [+Q] to distinguish these from non-quantificational adjectives like *kalos* (good), *oreos* (nice) etc. Thus, dispensing with an additional and not self-evidently necessary QP mode makes the specifier system look more unified and simple. The same notational simplification has been proposed for English too (cf. Gazdar 1979, Bresnan 1973: "the label QP is merely a temporary convenience; ...further research on partitives, quantifiers and adverbs will be necessary

to determine the categories involved" (p. 277).

2.1.2 The two specifier positions of the NP: N" and N'

Not all A [+Q] can be preceded by the definite article. It is only the quantifiers *polis* and *lighos* that can be preceded by the definite article, whereas items like *arketos*, *meriki*, *kabosos* cannot:

9. I {poli} mathites
 {liyi}

The {many} pupils
 {few }

10. *I {arketi} mathites
 {meriki}
 {kabosi}

the {several} pupils
 {enough }

In addition to this, quantificational items occurring in 10 cannot be themselves modified by (degree) adverbials (*toso*, *pyo*, *poli*), whereas *polis* and *lighos* can. Finally, *polis* and *lighos* are more 'predicate-like' than the quantificational 'adjectives' occurring in 10³, e.g.:

11. Ta pola/ligha vivlia

11a. Ta vivlia ine pola/ligha

12*. Ta vivlia ine merika.

In other words A [+Q] like those in 9 can occur in both attributive and predicative positions, like ordinary adjectives. These differences between the two subclasses of quantificational adjectives suggest that the structural

positions they occupy within the NP are different. Thus, the inability of the A"[+Q] in 10 to co-exist with the definite article shows that these are in complementary distribution; possibly, that the former being in the position of the articles are themselves articles of a sort, and their non co-occurrence amounts to a syntactic constraint, "namely the availability of only one Art position in the NP Specifier" (Jackendoff 1977:104-5). Given that the article, since it precedes all other specifiers of the head noun, is attached at the highest level, in our convention N", *kanenas*, *meriki*, *arketi* etc. are also in that position (corresponding to Jackendoff's N" Q). In other words, since articles are inflected for person, number and gender, I assume, according to their distributional behaviour, that items like *meriki*, *kanenas*, *kabosos* are articles, and that their quantificational character is shown by the feature [+Q] under Art; accordingly we stipulate that $\text{Art}[+Q]^4 = \{\textit{kanenas}, \textit{meriki}, \textit{arketos}, \textit{kabosos} \dots\}$. Along these lines, I further assume that the traditionally called 'indefinite article' *enas* (masc.), *mia* (fem.), *ena* (neut.) (one/a) is also [+Q], as the existential quantifier (cf. Al.-And. @ D.:65). This corresponds to the English singular *some*, whereas its plural [↖]corresponding is *meriki* (appearing exclusively with plural count nouns) and corresponds to the English plural *some*. Thus, we arrive at an interesting generalization. All categories characterized by the classical grammar of MG as indefinite pronouns are articles - in parallel with what is established to be called 'indefinite article' - , because of their distribution within the NP, and, in addition to that, they are, semantically, quantificational, as existential quantifiers (cf. "All members of the grammatical category of indefinite pronouns can be regarded as quantifiers of some sort" (ibid.)). Now, the only [-Q] element

belonging to the Article position is the definite article *o* (masc.), *i* (femi.), *to* (neut.) (the). Therefore the feature [$\pm Q$] seems appropriate for the Art node. This feature interacts with the [$\pm def$] of the higher NP(:N'') in the following way: if N'' is [-def], then Art will necessarily be [+Q], if the former is [+def], then the latter will be [-Q]. This interaction can be plausibly represented by the following feature co-occurrence restriction:

$$\text{Art} , [\alpha \text{ def}] \supset [\beta Q]$$

Then, given the following rule for N'':

$$\begin{array}{c} [\text{Art} \quad \text{N}'] \\ \text{N}'' \end{array}$$

and the fact that we can make *def* and *Q* foot features - i.e. that the N'' is [$\pm def$] or *Q* not because of some property of N but because of some property of its specifier - the FFP carries [$\alpha \text{ def}, \beta Q$] from Art onto N'' as required.

A. [+Q] like those of 9 are, then, in N', as they are preceded by the definite article; the rule expanding N' is:

$$\begin{array}{c} [(A'') \text{N}'] \\ \text{N}' [\pm Q] \end{array}$$

The [$\pm Q$] feature under A'' shows that ordinary adjectives, such as *kalos*, *omorfos*, etc. belong here too (cf. Jack. 1977:105).

As expected, Art[+Q] and A[+Q] - i.e. the two [+Q] categories in N'' and N' - cannot co-occur within an NP, since this is prohibited by the Specifier Constraint

cited on p. 41, which determines in effect that only one [+Q] node can precede the head; thus, bad strings like:

- 13.*a Arketi poli anthropi
- *b. Kabosi liyi . anthropi

are blocked. Furthermore, assigning *meriki* etc. to the category of Article explains why they cannot be further modified by degree items (cf. ex. 15a-b) - which as we shall see later on are also articles (i.e. [+det], cf. note 4). Since degree words - given they occupy the position in A'' that Art occupies in N'' - modify adjectives, they do not modify articles, so **tosu meriki* etc. are bad. According to what we have said so far, the following tree-diagram corresponds to the proposed rules:

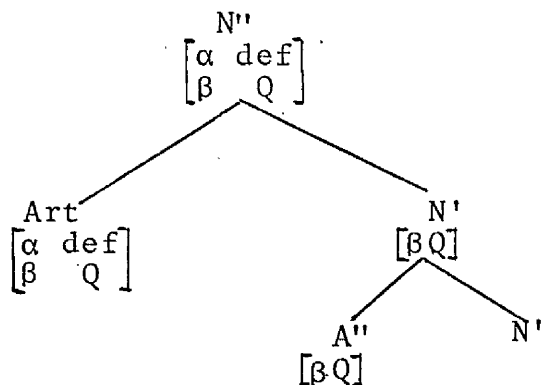

The features def and Q under N'' arise by FFP from the corresponding features on Art''. The variables αβ show co-occurrence restrictions of these two features. In the same way the feature [βQ] on N' arises by FFP from the corresponding feature on A''.

2.2 The internal structure of the AP

We said earlier that nouns can have prehead adjectives, marked as [±Q]. In considering the internal

structure of A'', we shall begin with A''[-Q], i.e. ordinary attributive adjectives (see section 3). The sort of A [-Q] we shall deal with is illustrated below

- | | | | | | |
|--------|----------|-------|----|------------|-------|
| 14. a. | Toso | kalos | d. | Ipervolika | kalos |
| | So(much) | good | | Extremely | good |
| b. | Poli | kalos | | | |
| | Very | good | | | |
| c. | Pyo | kalos | | | |
| | more | good | | | |

These are primary - basic - strings showing adjectives preceded by (degree) adverbials. We shall also deal with more complicated cases, ones that result from permissible combinations of the adverbials *toso*, *poli* (*ligho*), *pyo*.

2.2.1 What are Degree Words ?

First of all, we must see what these 'degree' words are.

In Jackendoff's version of X'-Syntax, degree words are defined as a special class of adverbs that are attached in X''' where X represents A, Adv, Q. These are *that*, *too*, *as*, *so*, *how* and the comparative specifiers *more* and *less*⁵. Degree words being in that position are exactly parallel to *Art*''' in N'''. This parallelism between Deg''' and Art''' is reinforced by the distribution of *this* and *that*, and *enough*:

| | | |
|---|----------------|---|
| { | that man | } |
| { | that tall/far | } |
| { | enough pudding | } |
| { | enough far | } |

Accordingly, Jackendoff's phrase structure rules showing this parallelism and the generalization with respect to the appearance of degree words are:

A''' → (Deg''')-A''
Adv''' → (Deg''')-Adv''
Q''' → (Deg''')-Q''
N''' → (Art''')-N'' .

In terms of feature notation these rules are collapsed as:

$$X \left[\begin{array}{l} +\text{Subj} \\ <+\text{Comp}> \\ -\text{obj} \\ -\text{Det} \end{array} \right]''' \longrightarrow \left(\left[\begin{array}{l} <+\text{Subj}> \\ -\text{obj} \\ -\text{comp} \\ +\text{Det} \end{array} \right]''' \right) - X''$$

Thus, the common features [-obj.-comp+Det] are shared by both Art and Deg. Ordinary (not degree) adverbs are [-Det]. The feature [+Subj] is added for articles, being [-Subj] for Degree words. It is worth examining a little more closely the presence of degree adverbials in adjective phrases. Adjectives in English do not take simple quantifiers as modifiers, but, instead, are modified by items which in turn can specify quantifiers:

- * much beautiful, so beautiful (cf. so much)
- * little clever, too clever (cf. too little)

Nevertheless, there are at least two 'exceptional' adjectives (Huckin(1977) shows that there are more than two, as, for example, past participles, used as adjectives) - *alike* and *different* - that can be preceded by quantifiers:

much different
so much different

Jackendoff accounts for these two possible forms by two corresponding base forms, which reflect the "unusual subcategorization possibilities of these adjectives" (Jack. 1977:147):

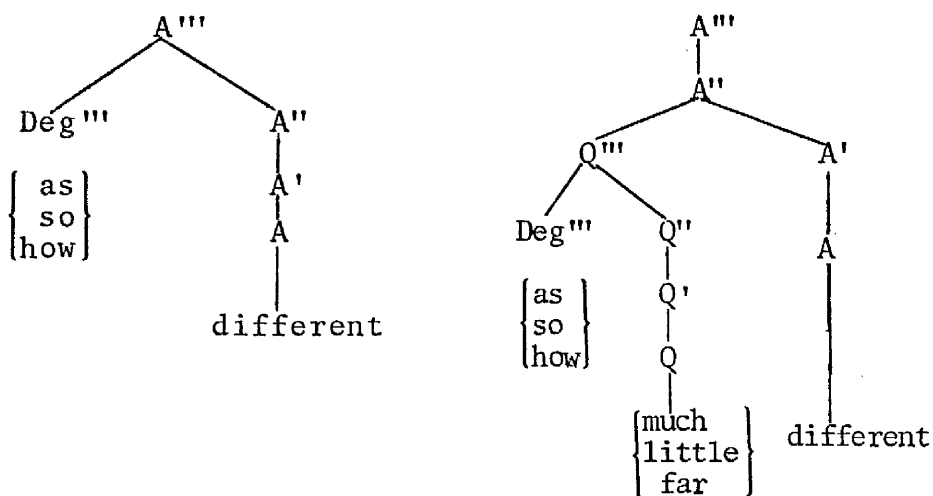

This, while making Bresnan's (1973) 'much-deletion' rule unnecessary, provides further evidence that "Deg''' is generated in A''' and Adv''' as well as in Q''', yielding a further cross-category generalization in the specifier system" (ibid.).

Jackendoff further claims that degree words are further modified by quantifiers or 'measure phrases' (see the relevant section for the definition of measure phrase). The dependence of measure Ps or QPs on the presence of degree words (cf. *five times many, five times as many). shows that recursion is through Degree. "Furthermore, which measure phrases and . quantifier phrases are possible depends on the choice of degree word...." (Jack. 1977:158). The attachment of these specifiers is in Deg'', so that another generalization can

be made - the attachment of QPs to X'', where now X'' includes also Deg. We cite Jackendoff's tree 6.42 to illustrate this:

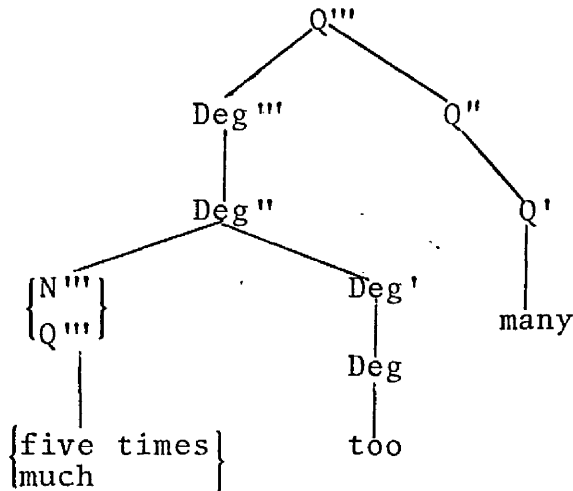

As seen in the above tree-diagram, the use of measure phrases also applies with complete generality - i.e. these, too, are specifiers of X'' (cf. p. 93). In Jackendoff's system quantifiers (and measure phrases) occur as specifiers of X'', where X'' stands for NPs, APs, VPs, PPs, and Degree Phrases (see Jackendoff 1977:166). Bresnan's (1973) account of the relation between QP and AP is different. QP is here defined as a quantifier-like structure which dominates Q (like *much*, *little*, *many* etc.) and which modifies adverbs, adjectives and nouns. On the other hand, members of this phrase can also modify other QPs, which means that QP is a recursive node, cf.:

Many too many too many.....

The question that arises is where exactly this recursion appears in QP. Bresnan rejecting the view that it goes

through the determiner of QP (i.e. the Deg of Jackendoff's) in a structure like:

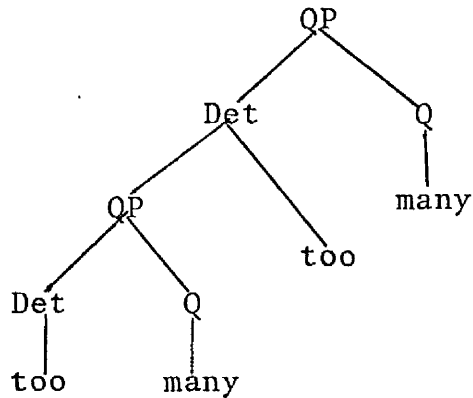

adopts a structure in which the QP' allows for left-branching structure keeping QP as a single constituent⁶, cf.:

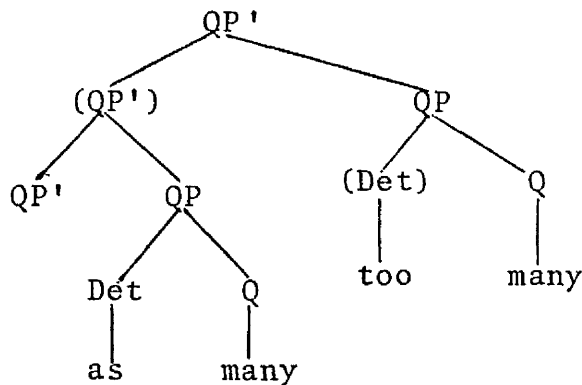

Thus, the following rules representing the internal structure of QP will be paralleled with the rules giving the internal structure of AP, :

QP' → (QP')QP
QP → (Det)Q

AP, which is not distinct from Adverb Phrase, is also

left branching, like QP:

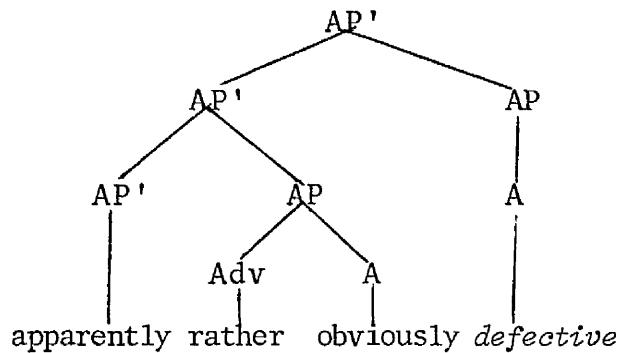
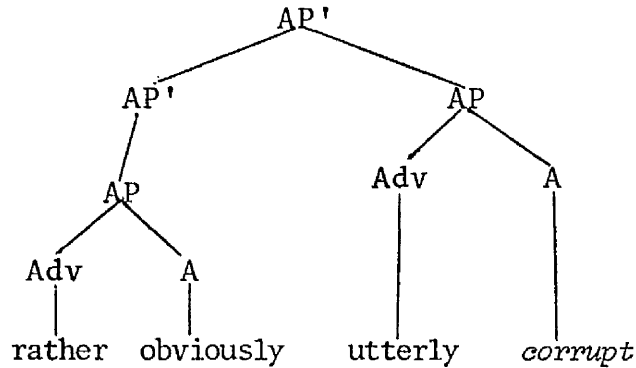

It is clear that AP' is parallel to QP' and Adv is structurally equivalent to the Det of QP. It is important that the class of elements occupying Adv in the above structures is not related to attributive adjectives, but rather constitutes a special class of intensive words, e.g. **Mary is utter*, **Mary acted utterly*. "The attributives *perfect* and *real* are quite different *semantically* and *syntactically* from the Adv *perfectly* and *really*, which have little to do with perfection or reality" (Bresnan 1973:292)⁷. Her rules for AP' are:

AP' → (AP')AP

AP → (Adv)A

A further generalization holding between AP and QP is the fact that they appear to be interchangeable: QP' does not only modify APs but is also modified by them, e.g. *more corrupt, obviously too much, noticeably more*. Thus, keeping the notation AP, NP and QP (for a 'mixed' category sharing features of NP and AP (and for this reason characterized as a 'merely temporary convenience' (Bresnan 1973:277)) a simple way to express the structural - and functional-close relationship between AP and QP would be the following 'collapsed' rules:

$$\begin{Bmatrix} \text{AP}' \\ \text{QP}' \end{Bmatrix} \rightarrow \begin{Bmatrix} (\text{AP}') \\ (\text{QP}') \end{Bmatrix} \begin{Bmatrix} \text{AP} \\ \text{QP} \end{Bmatrix}$$

AP → (Adv)A

QP → (Det)Q

M.L. Rivero (1980^b) claims for Spanish that Qs and degree quantity adverbials are parallel as specifiers of X'', but the two categories cannot be collapsed because (a) Qs agree in number and gender with the noun they modify, whereas adverbs do not:

tan pocos libros (tan = adverb of degree.)

(cf. toso ligha vivlia (see p. 82))

but *tantos pocos libros (tantos is Q)

(cf. tosa ligha vivlia)

It would be proposed, Rivero goes on, that Qs, like adverbs, are dominated by NPs, rather than AdvP, and this aspect determines the application of number/gender agreement for Q but not for adverbs. However, adverbs

modify nouns and are dominated by NP (cf. also note 1) with no agreement:

asi de vino

so of wine - so much wine

(b) QPs without degree adverbials cannot be further modified by other QPs (cf. Jackendoff's aspect of recursion through Deg, p.54 above). Degree or quantity adverbials can be modified by other adverbials of the same class. QPs that contain degree or quantity adverbials can be further modified by other adverbials or Qs. According still to Rivero, recursion must be seen as a property of adverbial phrases but not of Q - consequently the two categories must be distinct.

2.2.2 The basic structure of non-quantificational Adjective Phrases

Now, we can return to our examples 14.a-d. Some explicatory notes are in order here. First, exactly as in the case of adjectives, I also assume that adverbs are divided into [+Q] and [-Q]. Following the current Grammar book of MG (Neoelliniki Ghrammatiki (tis Dhimotikis), 1978), among Adv [+Q] are *poli*, *ligho*, *arketa*, *kaboso*, *skhedhon* (nearly, almost), *komati* (a bit), *peripu* (almost, approximately), *katholu* (not at all), *tulakhiston* (at least), *para* (too) and the comparatives *pyo* and *perisotero* (more). Adverbs [-Q] are those corresponding to ordinary attributive adjectives (so-called 'modal') like *ghrighora* (quickly), *omorfa* (nicely), *sosta* (right) etc.

There is still another class of (modal?) adverbs, which should be called 'intensifiers', corresponding to

Adv in the structures of Bresnan's sketched above. These have a meaning which can be considered close to that of *Adv* [+Q], because they cannot be preceded by other quantificational specifiers (apart from *toso*) (e.g. **poli apistefta omorfos*), but unlike other *Adv* [+Q], they can be followed by them, cf.

- 15.a. {*Apistefta* } *poli omorfos*
 {*Ekpliktika* }

 {incredibly } much beautiful
 {surprisingly }
- b. * {*Arketa* } *poli omorfos*
 {*Peripu* }

 {enough } much beautiful
 {almost }

Secondly, *toso* (that, as, so) and its interrogative and wh- counterparts *poso* (how/how much) and *oso* (as much) are also *Adv* [+Q]. The crucial difference, however, between quantificational adverbs on the one hand and *toso/poso* on the other is that these two can modify the *Adv* [+Q] *poli* and *ligho*, while adverbs like *arketa*, *skhedhon*, *katholu* etc. cannot. We shall propose means to account for this distributional idiosyncrasy of *toso*, namely, that it can be marked as + or - Q. The same obtains for the adverb *para* (too much). But now, the difference between the latter and *toso* is that *para* always precedes *poli*, whereas *toso* precedes it optionally. I shall suggest that the feature [+pol] (=poli(s)) accounts for this difference.

2.2.2.1 Non-comparative quantificational adverbs as
specifiers of adjectives

In a way parallel to the distribution of the various specifier elements within NP (cf. pp. 48-49), those Advs [+Q] that cannot be preceded by any other quantificational expression (e.g. by *toso* or *pyo*) will be attached under A'' as sisters of A' (*arketa*, *komati*, *kaboso*, etc.). The adverbs *poli* and *ligho* will, then, be under A', much as the corresponding adjectives are under N'. Notice that *poli* and *ligho* can be preceded by *toso* (*poso*). (but cf. p.61 onwards). It is by virtue of this property of *toso* that it can be assigned the category *Deg(ree)* being parallel to *Art(icle)* in NPs, which can precede the [+Q] adjectives *polis/lighos*, placed for this reason under N'. But *Degree* is also an appropriate label for other Adv [+Q] under A'' (like *arketa*, *kaboso* etc.), as *Art* was for the corresponding 'articles' *arketos*, *kabosos*, *meriki* etc.

According to the above assumptions, 14 a,b,d are assigned the following structures

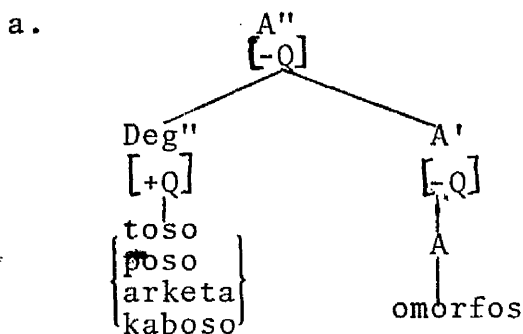

b.

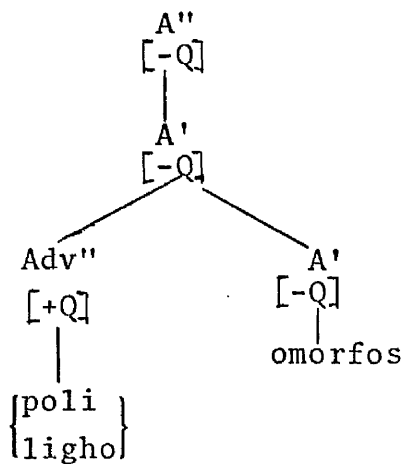

We said above that *toso* can precede *poli* and *ligho*.
In fact we get strings like:

- 16. a. Toso poli omorfos .
- b. Toso ligho omorfos
- c. Toso poli ligho omorfos

What structure is suitable for 16 a-b? There may be two possible structures. The one is a 'collapsed' form of a and b, represented here as c.

c.

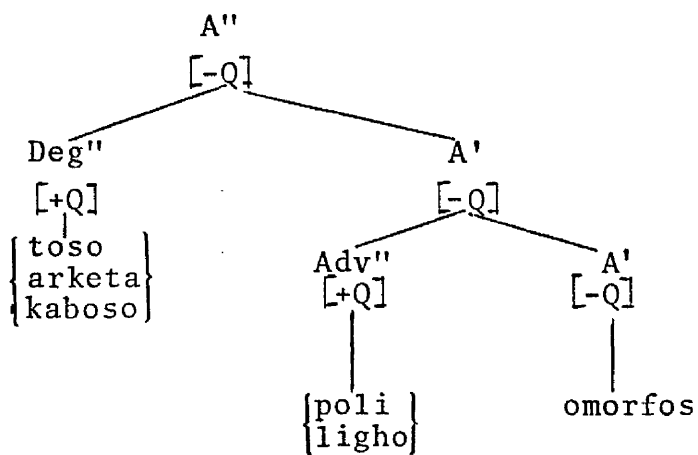

The other is d:

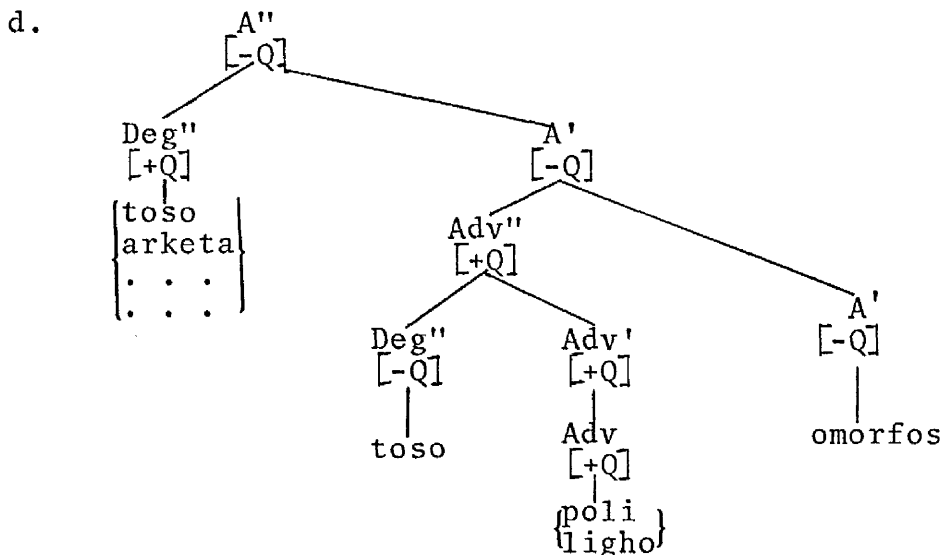

As it stands c is bad because there are two [+Q] specifier nodes (Deg'' and Adv'') and strings like 16a-b should be ruled out by some generalization of the Specifier Constraint (cf. p.41), but they are not. In d *toso* is a specifier of the Adv'' and assigned the feature [-Q]. Which of the two structures is correct for 16 a-b? The answer defending d is primarily based on intuition since it is strongly felt that *toso* forms a constituent with *poli/ligho* in 16a-b, and further justified by pairs like:

17.a. Toso poli ine exipnos!?(and: poso poli ine exipnos ?)

so much is-he clever !

Is he so clever ?!

b. Toso poli, ne !

So much, yes !

(Yes, he is so clever !)

The constituency of *toso* (*poso*) *poli/ligho* is also supported by intonation: *toso* and *poli* form one intonation group. At this point, it is worth making some clarificatory notes concerning structures a-d. First of all, the feature [-Q] under A" is considered as a head feature. This is stipulated, for the reason that we have classified adjectives as [+Q] and [-Q] and we want this distinction^{to} remain clear throughout our discussion of their internal structure. Here we are dealing with [-Q] adjectives. The feature specification under A" could be [+Q] too, but then this would be a foot feature, which would climb up to A" from its specifier by the FFP. Now, this would obscure things, and it would not be clear anymore whether the adjective that carries this feature is a quantificational one or whether that feature comes from the specifier of the adjective as a foot feature. Exactly the same holds for Adv" branching from A'. The [+Q] is a head feature concerning *poli/ligho*, not a feature coming from Deg (i.e. *toso*). Therefore *toso* is not required to be [+Q]. The reason why we suggest that *toso* may be + or -Q is twofold. First, this reflects the fact that *toso* may or may not be followed by a [+Q] adverb, but in either case it is 'quantificational'; in the first case the quantifying function is undertaken - so to speak - by the quantificational adverb, in the second case, where such an adverb is missing, *toso* is [+Q] as genuinely (inherently) quantificational. Second, this alternation of *toso* is very much reminiscent of the corresponding English degree word *so*, which is either *so* [+Q] or *so much* ([-Q] [+Q]). The same remarks concern *pyo*, the comparative morpheme (see below).

Now, given Adv" under A' is [+Q] bad strings like

18.* Arketa poli omorfos

* Enough much beautiful

19.* Toso { toso } poli omorfos
 { arketa }

* So { so } much beautiful
 { enough }

are blocked either by the specifier constraint (18), or an haplology-like constraint (19), or by the fact that there are not two article (or, equally, degree) positions within an NP or AP (19, see p.41). One could now ask why *toso* in c is [+Q]. Could it also be [-Q]? According to our theory, as illustrated above, it cannot. First of all *toso* is inherently quantificational, corresponding to the English *so (much)*. It is worth mentioning here that its wh-counterpart *oso* can hardly specify a following *poli/ligho*, since the notion of quantity is inherent. Thus, intuitively, *toso* used alone is [+Q]. If, however, it is followed by *poli* - i.e. if it is analysed - so to speak - into its semantic components - it can be [-Q] (*so much'), since *poli* is anyway [+Q] (see above). On the other hand if *toso* was [-Q] in c - i.e. if Deg was [\pm Q] - then, we should explain in some other way why *toso* (*poli omorfos*) is not the case, in other words why c is not the right structure for 16a - the Specifier Constraint would no longer be operative.

Before I give a possible structure of 16c, I should say that I assume *poli* in *toso poli ligho omorfos* is not an Adv [+Q] - like the English *much* - but a different word. It is rather an intensifier - like the English *very* - which combines with *ligho* to form its superlative (and only marginally - maybe with a stylistic effect -

with the Adv [+Q] *poli*).

Second, what about the position of the adverbs we called intensifiers ? This question is related to another: is the specifier position in A' occupied solely by the quantificational adverbs *poli* and *ligho* ? The answer seems to be negative here. In the following examples we can see that an adjective or, (sometimes more often) a participial adjective can be modified by a modal adverb (i.e. an adverb of the same sort as the modified adjective), cf.:

- | | |
|---|--|
| 20. Toso omorfa dhinatos So(much)nicely strong | 23. Aprokalypta eskhros Obviously rude |
| 21. Elafria dimenos Lightly dressed | 24. Stathera epipoleos Steadily frivolous |
| 22. Isya valmenos Straight put | |

Bresnan, as already mentioned, considers AP (adjective or adverb phrase) a recursive node, so that an adverb can modify an adjective (we must recall that QP in her analysis is a category distinct from AP, cf. her trees on p.55-56). Examples 20-24 show that there is evidence for such a view, and although I do not consider this evidence conclusive (e.g. in the majority of cases where an adverb modifies an adjective this adjective is a past participle - thus a 'verbal' category which can naturally be modified by (modal) adverbs), I shall adopt this point of view, i.e. I shall consider A' as a recursive node, stressing, however, that semantic considerations are decisive with regard to the exact choice of modifying adverbs and the correct combinations of adverbs-adjectives. Thus, we arrive at a structure looking more or less like

e below, parallel to the one exhibiting an A'' [-Q] position within NP

e

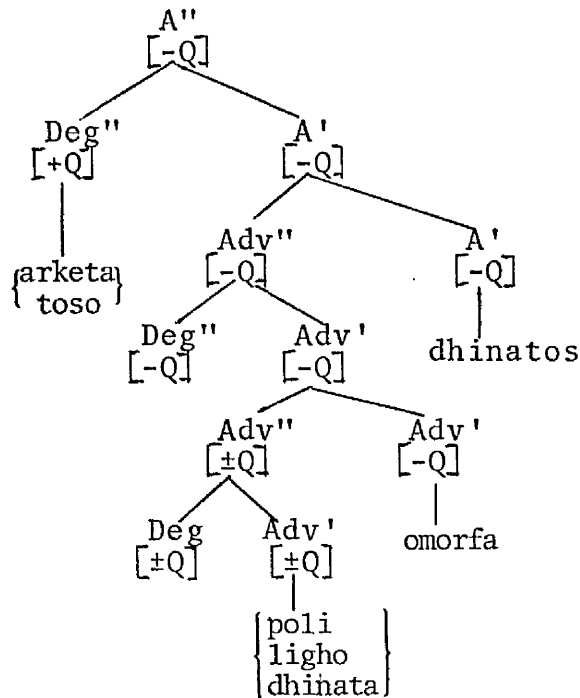

Here we have the problem of excessive recursiveness on Adv'' [-Q], of which no examples are offered by Bresnan. If e is a possible structure, we have to assume that this sort of recursiveness is accounted for by various semantic constraints or even performance factors. I cannot offer a definite solution to this problem. Anyway, the adverbs we called intensifiers are not common modal adverbs. I assume that their role is to 'magnify' the meaning of the head adjective (or adverb) - in a function similar to that of [+Q] categories. This is the case in 16c. I assume that *poli* on the left of *ligho* is not a quantificational adverb, because in that case the sequence *poli ligho* would be ruled out by the Specifier Constraint, but an intensifier that combines with *ligho* to form its superlative (cf. p. 64). For this reason I shall mark it as [+sup]. The following examples show that *poli* and *ligho* form a constituent.

25. a. Poso omorfos ine ?
 How beautiful is he ?
 b. Poli ligho !
 Very little !
 c. Elakhista !
 Very little (minimally)

Elakhista is the synthetic superlative form of *ligho* (cf. Neoelliniki Ghrammatiki (tis Dhimotikis) 1978:274), therefore, if our assumption about *poli* is correct, *poli ligho* and *elakhista* cannot co-occur; in fact this must be true because of 26(a-b).

26. a.*Poli ligho elakhista omorfos
 b.*Elakhista poli ligho omorfos

I, therefore, propose the following structure for 16c:

f

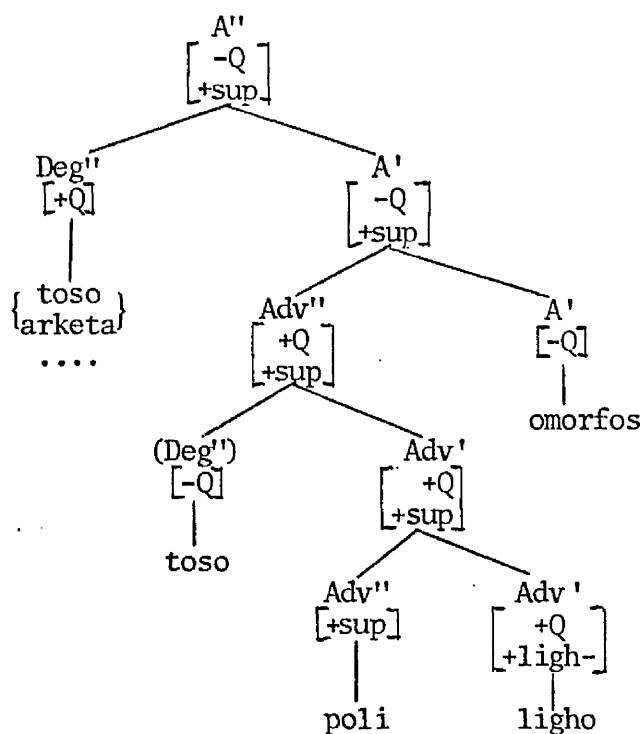

The feature [+sup] climbs up to A' from its specifier (Adv'') by the FFP. The feature *ligh* - on Adv' [+Q] makes it expand as *ligho*, thus prohibiting the appearance of **poli poli*, though this is very *ad hoc*. If the Adv'' [+sup] is missing as a specifier of Adv' [+Q], then the feature [+Sup] will be a (foot) feature on Adv'', along with [+Q] and [+ligh-]. Adv'' under A' will then be [+Q +sup(+ligh)], spelled out as *elakhista*, or, if (+ligh-) is missing, as any adverb which indicates the superlative degree of the adjective, such as *katapliktika*, *afandasta*, *apithana* etc. *omorfos*, *exipnos*. The relevant structure will accordingly be:

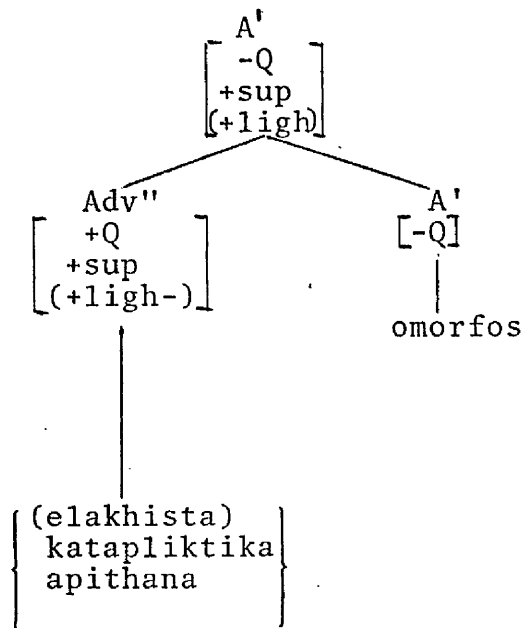

This structure predicts the ungrammaticality of **apithana elakhista omorfos*. If the Adv'' [+Q] under A' in f is *poli* instead of *ligho*, those adverbs called intensifiers occupy the position of the specifier of Adv' [+Q], in parallel with *poli*, forming thus the superlative of the quantificational *poli*; cf. 27, parallel to 16c:

27. (?Toso) ekpliktika poli kalos
 (so) amazingly very good ,

where *ekpliktika* is [+sup] and *poli* [+Q], and 28, parallel to 25a-b:

28.a. Poso omorfos ine ?

b. Ipervolika poli !

Then structure f will be modified as g:

g

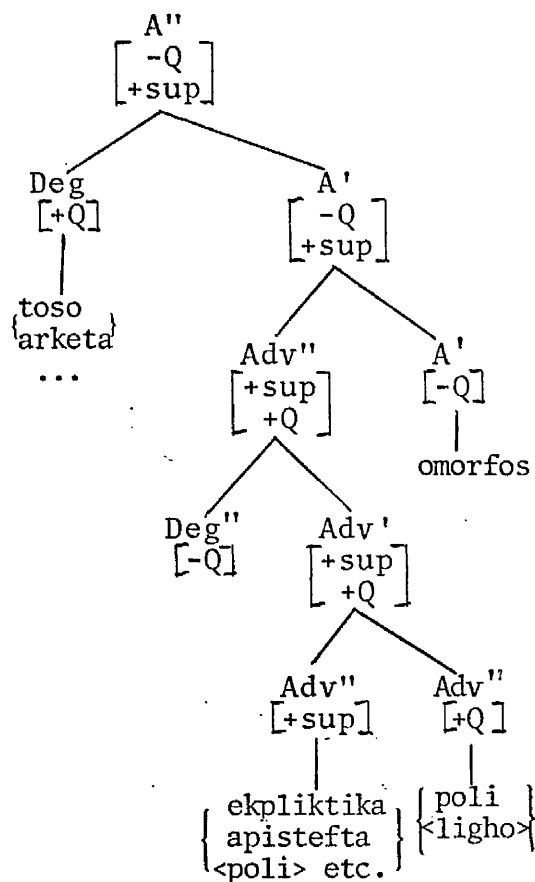

Here the feature [+pol] under Adv[+Q] is not needed

because this can be also modified by other superlative intensifiers - apart from *poli*. The fact that *ekpliktika poli* forms a constituent and at the same time the superlative form of the adjective receives additional support from example 29, which shows that *ekpliktika poli* and the synthetic superlative form of the adjective* cannot co-occur.

29. *(Toso) ekpliktika poli omorfotatos
*(so) amazingly much beautiful (superlative)

With regard to the questioned *toso* in 27 as well as in.

30. (?Toso) poli ligho omorfos

we must say that the feature [-Q] under Deg allows it

*We get the synthetic superlative form of the adjective as follows:

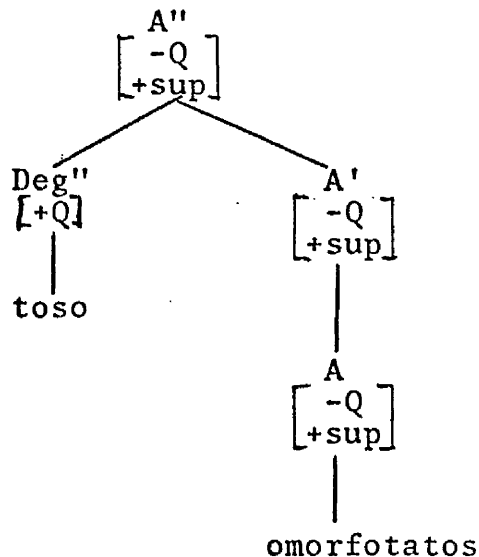

Thus, we observe the following asymmetry: while the synthetic superlative of *ligho omorfos* is exclusively formed as the sequence *elakhista omorfos*, that of *poli omorfos* is formed as *omorfotatos*. I.e. the Adv'' [+Q+sup+ligh-] specifier is indispensable in the former case, whereas in the latter case it is not (cf. Neoelliniki Ghrammatiki (tis Dhimotikis), 1978:274) .

to modify the [+Q] Adv". In other words *toso* in 27 and 30 is the degree modifier of the Adv"[+Q] not the upper *Deg* of A". The latter is excluded as a modifier of the A" [+Q] by the Specifier Constraint.

Now, if we have the synthetic superlative form of the adjective (*omorfotatos, oreotatos* etc.), there will be no specifier (Adv") of A', but the foot feature [+sup] under A" will ascend directly from the head adjective by the FFP (see footnote p. 70). Then *toso* must be excluded in front of *omorfotatos*:

31.* Toso omorfotatos

I don't know how, maybe by some generalization of the Specifier Constraint not allowing the co-occurrence of a quantifier and an intensifier (i.e. a superlative form) (Notice that *toso* is allowed before the synthetic form of a comparative adjective). I think a semantic constraint may well be right - i.e. if 'X is tallest' then there is no question of specifying the degree to which he is tallest. Superlatives are absolute and do not admit of gradation.

2.2.2.2 Recursion and the comparative adverbs pyo/perisotero

Jackendoff includes the comparative specifiers *more, less* among the ordinary degree words, *so, as, this* etc. Consequently, *more/less* appears in both Q'" and A"". In the former case spelling rules will yield the correct forms from *more many, more far* etc. With regard to *less*, only one such possibility exists: *less far*. Clearly, **less much, *less little, *less few* are bad and these *less-Q* combinations must be ruled out, cf.

"The bad forms, if they existed, would presumably be synonymous with the existing forms *more little > less*, *more few > fewer*, *more much > more*, *more many > more*, respectively, which somehow seem 'less negative'. This fact may be useful someday in giving an interesting account for what must remain for now an unprincipled filter" (Jack. 1977:149). The rule forming comparative adjectives is claimed to generalize via the X'-Convention with the rule forming comparative quantifiers⁸.

Comparative adjectives in MG are illustrated in the following examples:

32. a. Omorfoteros
b. $\left\{ \begin{array}{l} \text{Pyo} \\ \text{Perisotero} \\ \text{Lighotero} \end{array} \right\}$ omorfos
c.? Pyo $\left\{ \begin{array}{l} \text{poli} \\ \text{ligho} \end{array} \right\}$ omorfos.

32.a shows the synthetic ('suppletive') form of the comparative adjective. The ending *-teros* is the usual ending of comparative adjectives. Following Gazdar (1979) I assume that in this case, the relevant feature [+comp] is a foot feature accounted for by the FFP:

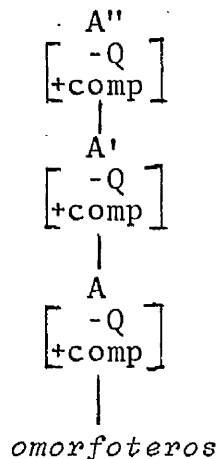

In 32 b the comparative adverbs (*pyo* etc.) appear as left modifiers of the adjective. Similarly, we have to assume that the feature [+comp] ascends onto A' from Adv'', in a way parallel to the superlative adjective (cf. p. 68):

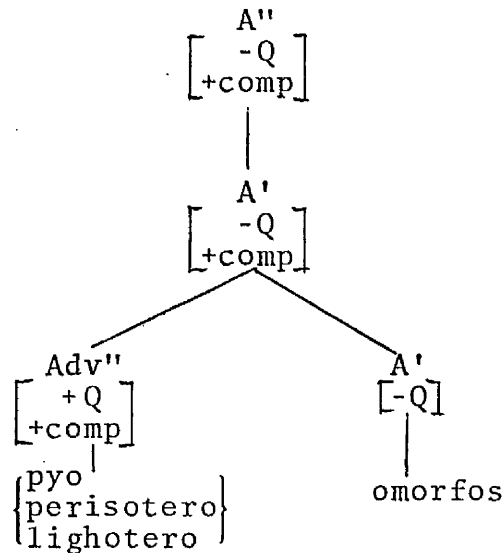

Finally in 32 c we observe that the comparative adverb *pyo* appears as a left modifier of the Adv [+Q] *poli* (cf. structure b p.61)⁹. Accordingly, structure b of p. 61 must be amplified as follows:

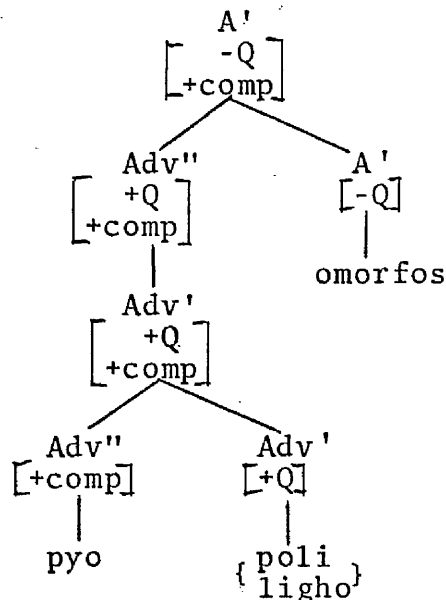

Thus we see that the correct distribution of the features [+Q +comp] and the basic structure b yield the desired forms of example 32. It must be underlined that Adv'' [+Q +comp] is available *only* in expansion of A', elsewhere [+comp] and [+Q] must be distinct (i.e. in expansion of Adv'). This guarantees *perisotero* and *lighotero* only occur immediately before an adjective [-Q] (**perisotero poli*, **lighotero poli*). This, more explicitly, means that *perisotero* and *lighotero* are exclusively specifiers of adjectives [-Q], whereas *pyo* is a specifier of Adv[+Q] as well. Our structures also reflect the fact that we have a gradual - as it were - transition from the synthetic to the analytic comparative form of the adjective. From *omorfoteros* we go to *perisotero omorfos* and from there, by an analysis of *perisotero* to its 'constituent' parts (+Q +comp) to *pyo poli omorfos*. Consequently the following strings are predicted to be bad, correctly:

- 33.a.*? *Pyo (poli) perisotero omorfos*
- b.*? $\left. \begin{array}{l} \text{Perisotero} \\ \text{Pyo (poli)} \end{array} \right\} \text{omorfoteros}^{10}$

But we have cases more complex than those illustrated in 32a-c. These result from further specification of the comparative adverbs *pyo*, *perisotero*, *lighotero*, cf.:

- 34.a. *Poli omorfoteros*
- b. *Poli pyo omorfos*
- c. $\left. \begin{array}{l} \text{Poli perisotero} \\ \text{lighotero} \end{array} \right\} \text{omorfos}$
- d. *Poli pyo poli omorfos*

One may ask whether the *poli* preceding the comparative adjective is a quantificational adverb (Adv[+Q]) or the

superlative *poli* (cf. structures on p. 61 and 67). Since the features seem rather to be in complementary distribution, and a superlative adverb is rather unlikely to modify a comparative one (on semantic grounds), I consider *poli* of 34a-d as Adv'' [+Q], exactly equivalent to the English *much more/less*, or *much taller* etc. We shall see below that this is further justified. Then, *poli* as Adv'' [+Q] will be attached in Adv' [±Q +comp] - i.e. as a specifier of *pyo*, *perisotero*, *pyo poli*⁹. It specifies the degree to which someone is more beautiful than someone else. This suggests that recursion comes through [+comp] - i.e. that the node bearing the feature [+comp] is a recursive node. Thus, the structure of 34 d must be like the following

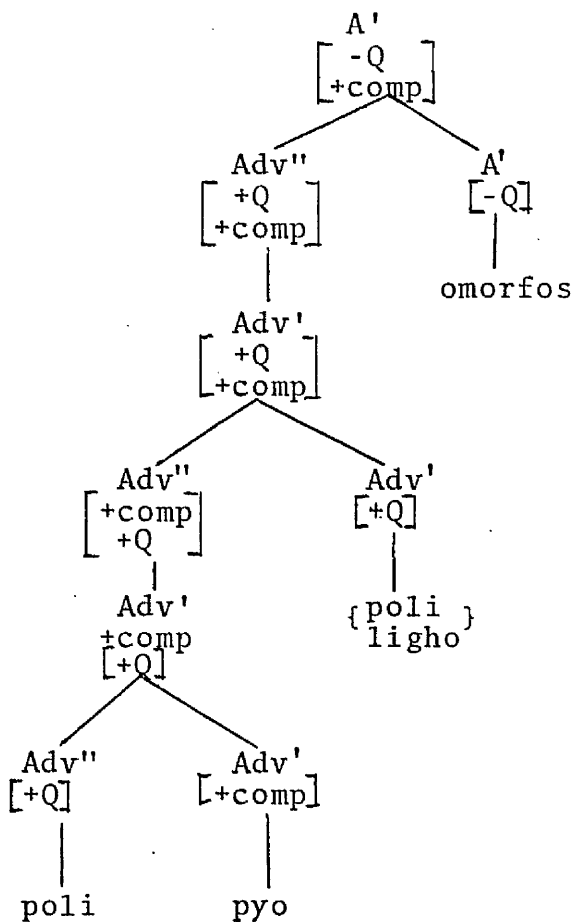

And now we can get even longer strings if the degree specifier *toso* precedes those of 34a-d and those of 32a-c as well. In both cases, *toso* is intuitively attached to the leftmost adverb every time. Thus in 32a *toso* has the position shown in the following structure:

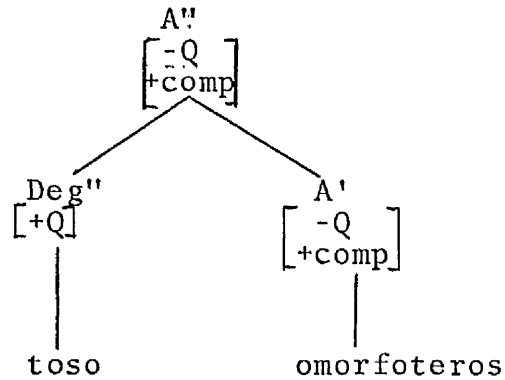

In 34d - to take the simplest and the most complex cases of modification - *toso* is positioned in the Adv'' [+Q]:

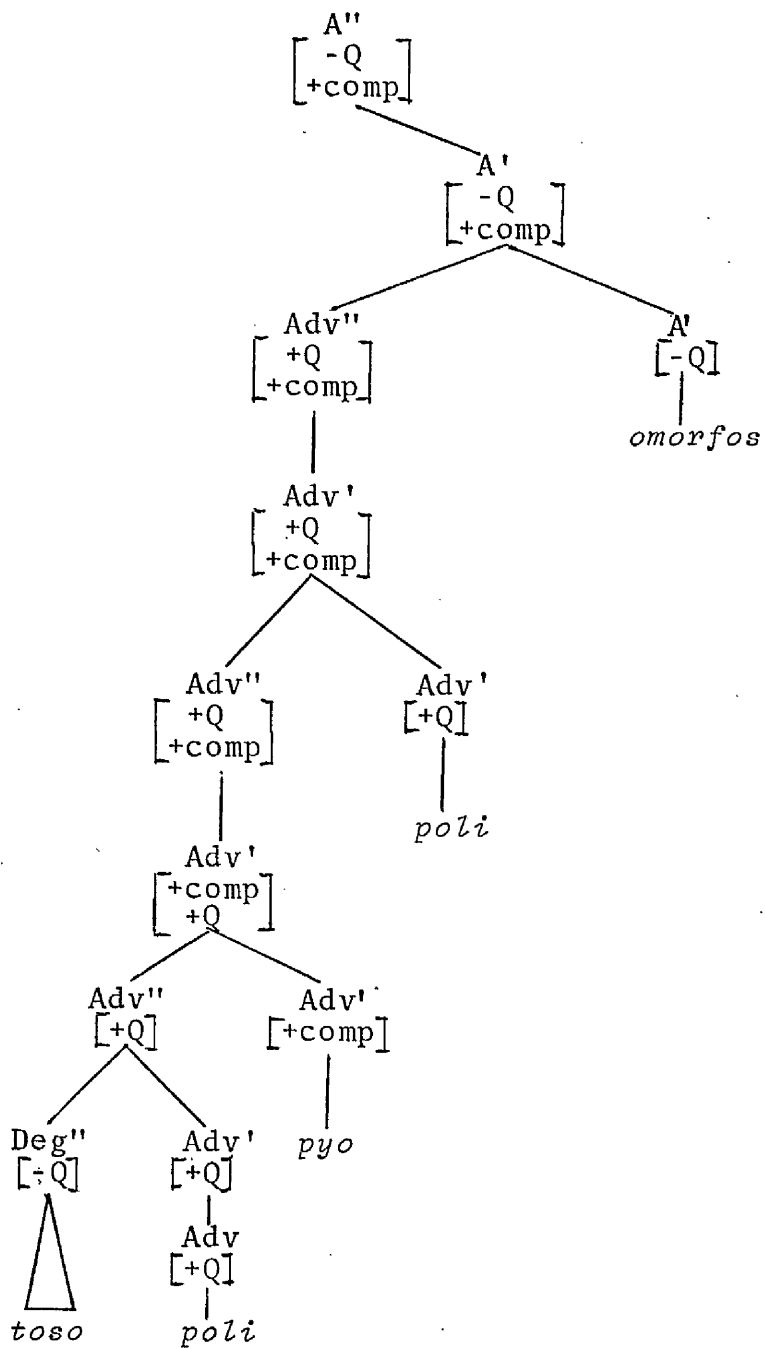

First, we must stress that the specifier constraint is not violated by the many occurrences of [+Q] nodes, for these are further expansions of a single specifier node of A - namely of A'. The specifier constraint says that no single head can have two (or more) [+Q] specifiers. Here it has one. Now, potentially, *toso* could belong to A" [+comp] or to any higher Adv". The strongest evidence for placing it at the 'lowest' (i.e. the leftmost) Adv" is intuition, as well as examples corresponding to 17; cf.:

35.a. *Poso poli* ine { *pyo* (*poli*), *omorfos*...?
 perisotero }

b. *Toso poli*.....

c. *Toso perisotero* (*lighotero*)...

Notice that this attachment of *toso* is not contradictory with the positions we claimed earlier that *toso* can occupy - in A" and in Adv [+Q]" (cf. pp. 60,62). And it is exactly the last structure that constitutes further evidence for the claim made earlier (p. 75), that *poli* in 34a-d is the quantificational and not the superlative *poli*. So, apart from what was said on p. 75 about its status, we see that this *poli* is specified by *toso*, whereas the superlative *poli* is not; cf. example 35a-c as well as the following pair:

[*toso* [*poli ligho*] *omorfos*].

*[[[*toso poli*] *ligho*] *omorfos*].

(However, there is not an obvious way to block *toso* as a specifier of the superlative *poli* (cf. g,p. 69). The strongest counterevidence for such an attachment is intuition. Nevertheless, the reason that accounts for the ungrammaticality of *toso omorfotatos* must be of some relevance here, too. Probably, a quantificational (or

degree) expression and a superlative adjective (or adverb) cannot co-occur). As a final argument for the [+Q] status of *poli* in 34, we could simply state the following contrastive examples:

- 36.a. * $\left\{ \begin{array}{l} \text{Poli} \\ \text{Ligho} \end{array} \right\} \left\{ \begin{array}{l} \text{elakhista} \\ \text{ekpliktika} \\ \left\{ \begin{array}{l} \text{poli} \quad \text{ligho} \end{array} \right\} \end{array} \right\}$
- b. $\left\{ \begin{array}{l} \text{Poli} \\ \text{Ligho} \end{array} \right\} \left\{ \begin{array}{l} \text{perisotero} \\ \text{pyo ligho} \end{array} \right\}$

Superlative adverbs are not recursive (once one is the 'best' there is no place left for comparisons - *how much best?), whereas comparative ones are (cf. p. 77). The only *poli* that can occur in 36a is the superlative *poli*, that which forms the synthetic form *elakhista* together with *ligho*.

2.2.3 The structure of AP marked as [+Q]

We shall now consider the adjectives [+Q]*polis* and *lighos*, which also are in N'. The following examples illustrate such cases:

- 37.a. Pola vivlia
Many books
- b. Polis kafes
Much coffee

We have already said that these, as immediately dominated by N', agree with the head noun in all relevant syntactic features. Moreover, we have already seen the internal structure of Advⁿ[+Q], when it is a specifier of [-Q]

adjectives. We, then expect the structure of $A''[+Q]$ to be the same as that of $Adv''[+Q]$. We shall see that in fact it is so.

First, the comparative and superlative form of the adjective is exactly parallel to that of the adverb:

38. a. $\left\{ \begin{array}{l} \text{Pyo pola} \\ \text{Perisotera} \\ \text{Lighotera} \end{array} \right\} \text{vivlia}$
- b. $\left\{ \begin{array}{l} \text{Poli ligha} \\ \text{Elakhista} \end{array} \right\} \text{vivlia}$
- c. Ipervolika pola vivlia

The only difference is that *pyo* here can never appear immediately before the noun¹¹ - as it did before the $A'[-Q]$ - it must always precede the $A'[+Q]$. Thus, as in the case of $Adv''[+Q]$, the feature $[+comp]$ ascends from (as a foot feature) the $SpecA'[+Q]$. In effect, the $SpecA'[+Q]$ position is occupied by the $[+comp]$ or $[+sup]$ adverbs (cf. structures f, g pp. 67,69). As expected, the $[+comp] Adv''$ can be so expanded as to include the $[+Q] poli$:

39. Poli $\left\{ \begin{array}{l} \text{pyo pola} \\ \text{perisotera} \\ \text{lighotera} \end{array} \right\} \text{vivlia}$ cf. 34.a-d.

Finally, we come to *toso*. Exactly as in $[-Q]A''$, it is a degree of $[+Q] A''$:

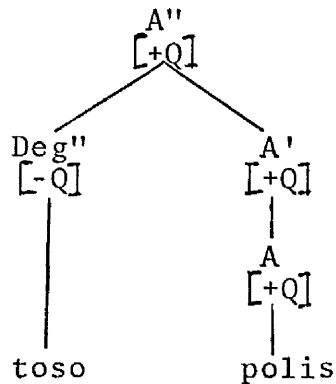

We assumed that *toso* if followed by the Adv *poli* is [-Q], if not it is [+Q]. Since this structure is exactly parallel to a. (p. 60) with respect to the occurrence of *toso*, we are obliged to assume that here, too, *toso* is [-Q]. (The same is true of *toso* preceding *poli* in 16a-c cf. p. 61). Here we arrive at an interesting generalisation. *Toso* appears to be a Deg not only of adjectives and adverbs [$\pm Q$] but of nouns as well. Thus we have:

40. Tosa vivlia

meaning *toso pola vivlia*. Since *tosa* is directly dominated by N, it automatically agrees in number, case, gender with it. And since we claimed that *toso* is a Deg in A(dv)'', we have to assume that *tosa* in 40 is an Art in N'' even at the cost of a complication of the feature system of Art; remember that it was assumed earlier (p. 48-49) that the only [+def] article is [-Q] - i.e. the definite article. But *toso* in the following structure is [+Q] (and definite). Unless, *tosos* here is considered as a Deg.

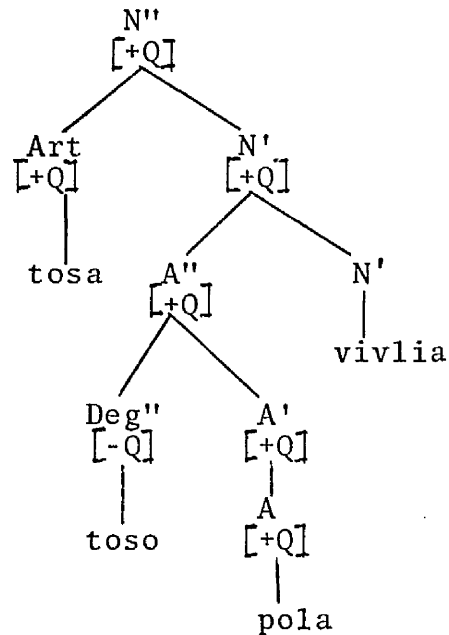

(The Specifier Constraint allows only one [+Q] specifier to appear). Notice that we have arrived at a structure precisely parallel to d of p. 62. The feature [+Q] ascends on N'' from the A'' - Spec of N' - by the FFP. The same holds for the features [+comp], [+sup], when there are such features. *Tosa* agrees with the noun for the reason already explained - i.e. it is formally an *article* in N'' (*toso*, as a specifier of adjectives, is an adverb, therefore no agreement requirements are imposed on it). I believe that the above structure can explain two rather curious facts about *toso* when 'embedded' within an NP; cf:

- 41. a. *Tosa pola vivlia*
- b. *Tosos poli lighos kafes*

It has already been mentioned that items not dominated by NP are not required to agree with the noun in gender, case, number (cf. Selkirk 1977). Along the same line,

Rivero (1980b) has also claimed that quantifiers are dominated by NP whereas adverbs are dominated by AdvP. This aspect determines the application of number and gender agreement for Q but not Adv. Is, then, 41a-b a violation of this rather universal principle? It is worth pointing out that 41a-b is constantly ruled out by traditional school grammars - precisely as a violation of the above mentioned principle - despite its widespread use (even in writing). Just for the sake of interest, I cite a letter to a newspaper ('Kathimerini' 19/11/1981), according to which example 41 constitutes a 'dangerous symptom'.

"Επικίνδυνο σύμπτωμα.

Επιτρέψατέ μου να παρατηρήσω με κάποια έκπληξη ένα σημαντικό όσο και συχνά εμφανιζόμενο τον τελευταίο καιρό στα δημοσιογραφικά κείμενα λάθη, που παρελσέφρυσε δύο φορές στη μετάφραση του άρθρου του Χάμμαπεργ (παρ. 2 και 6): "τόσοι πολλοί" αντί "τόσο πολλοί". Η μόδα αυτή να κλείνουμε τα επιρρήματα είναι πολύ επικίνδυνο σύμπτωμα - απ'αυτά που μας κάνουν πολλές φορές να μετανοούμε, οι παλαιότεροι δημοτικιστές, για τη γλωσσική μεταρρύθμιση...".

My view is that 41a-b is just an instance of 'confusion' or 'conflation' of the two words *tos-* - appearing in the structure of the previous page - a kind, as it were, of 'morphological attraction', carried out at the performance level. A very similar phenomenon is observed in comparative A [+Q], cf.:

- 42.a. *Poli perisotera vivlia* (cf. example 39 (p.80))
- b. *Pola perisotera vivlia*

Poli in 42a is an adverbial modifier of the adjective *perisotera* - indeclinable, of course. But as it is clear in 42b it undergoes a kind of morphological attraction to the adjective *perisotera* by which it is

dominated and it declines along with the latter.

'Correct' or not, 42b as well as 41 lend support to the claim made that *poli* forms a constituent with the adjective or adverb *perisotero(s)*, and that *toso* is a degree specifier of both the adverb and adjective *poli(s)*. We should not worry about the fact that adverbs are starting to decline, for 43(a-b) is clearly bad:

43. a. **Polis* lighos kafes

b. *(Tosos)*polis* lighos kafes (cf. 41b)

The superlative adverb *poli*, even before *lighos*, can never decline. This shows that it is the particular structure with two occurrences of *toso* (one declined, one not) that results in the idiosyncratic form *tosos*¹². In terms of the same structure the following fact can be explained:

44. a. Ta tosa vivlia

b. Ta toso pola vivlia

44a suggests that *tosos* may reasonably be assumed to be attached in N', since it can be preceded by the article - exactly like *polis* and *lighos*. On the other hand we would like to maintain that *toso* participates in a significant generalization: it appears as a 'degree' word in A'', Adv'', and N''. 44b complies with this aspect: *polis* is under N', *toso* is a degree of *polis* (in A'') and *ta* is an article in N''. So, *tosa* in 44a can be seen again as an alternative (conflation) of *toso pola* of 44b. We can stress here that the interrogative and relative equivalents of *toso* cannot be preceded by the article: cf.:

45. a. *Ta posa vivlia...?

*The how-many books ?

b. *Ta osa vivlia ekho dhen da ekhis esi
the as (many) books have-I not them
have you.

You don't have those (books) I have

46. *Ta osa ekho dhen da ekhis esi¹³.

Finally, if, despite the lack of conclusive evidence¹⁴, the attachment of *tosos* under N" is correct, and given that the adverb *toso* is a degree word in A", we get something parallel to the categorial ambiguity of *this/that* in English:

47. a. {That } man
{This }

b. {This } good/well.
{That }

2.2.4 Summary

To summarize what has been said so far, we can reach the following conclusions and make some generalizations.

Nouns are preceded by articles and adjectives. Both comply with the general and inviolable principle of agreement with the head noun¹⁵. Quantificational words that cannot be further specified by any item - much like ordinary articles - are assigned to the category Art. More explicitly, Art is the appropriate node label for those specifier items that appear leftmost under NP. Adjectives, which can be preceded by articles are in N'. Quantificational A in N' cannot be preceded

by quantificational articles (or vice versa) according to the Specifier Constraint.

Likewise, adjectives are not modified by other adjectives (cases like *kalos neos omorfos* are instances of recursiveness of N'), but only by adverbs. The A'' specifier position is occupied by the degree adverbial *toso* as well as the [+Q] adverbs *arketa*, *kaboso* etc. - corresponding to articles [+Q] in N''. The node label Deg - as corresponding to Art - comprises those items that are leftmost within AP. The following rule accounts for this:

$$\begin{array}{c} \text{[Deg'' A']} \\ \text{A''} \end{array}$$

It is interesting that the [Q] feature of Deg'' interacts with the [Q] of A'' (remember that the latter is a head feature) in the following way, as already stated and clarified; if A'' is [+Q], deg is [-Q] and vice versa (cf. p. 63). Accordingly, the above rule can be revised as

$$\begin{array}{c} \text{A'' [Deg'' A']} \\ \text{[αQ] [βQ] [αQ]} \end{array} \quad (\text{cf. note 18})$$

No 'bars' should typically be put on Art and Deg, but we shall see that there is one case of expansion of *toso*. We have divided adjectives into two classes, [+Q] and [-Q], thus dispensating with a category Q. The same, of course, holds for adverbs. [-Q] adjectives are specified by [+Q] adverbs in A', or by [-Q] adverbs in the same position - in a way parallel to NP, which has a [±Q] A'' in N'. As expected, the internal structure of [+Q] adverbs is the same as that of [+Q] adjectives. *Toso* as a degree specifier appears also in

Adv" [+Q]. Here it is [-Q], since its second semantic 'component' (*poli*-much) is explicitly stated by its following adverb *poli* (much). The same remark obtains for A[+Q]. Thus, the above rule accounts for these alternations¹⁶. If A" is [-Q] the Deg *tosó* will be [+Q] and vice versa. Strings like

- 48. a. *Arketa polis
- b. *Kaboso lighos

are ruled out by a generalisation of the specifier constraint, whereas

- 49. { Arketa }
 { Kaboso } omorfos

is O.K. The rule for A' is

$$A' \begin{matrix} [-Q] \\ [+Q] \end{matrix} \left[\begin{matrix} Adv'' \\ [+Q] \end{matrix} \quad A' \right] \quad (\text{cf. } N' \begin{matrix} [A'' \\ [+Q] \end{matrix} \quad N')$$

Here, we must briefly mention something only hinted at on page 65. We said there that A' must be considered as a recursive node. This is suggested by examples like 20-24 as well as 50a-b:

- 50. a. Atherapefta aprokalipta eskhros
 Incurably obviously rude
- b. Stathera strava topothetimenos
 Steadily wrongly put etc.

which, though not so common, are nevertheless possible strings. We shall see in the next paragraph (3 p.124) that an extra level is necessary in NP as well, i.e. N' must be recursive to accommodate an infinite - in principle -

number of adjectives. On evidence, then, from both AP and NP it appears that X' must be recursive, so that the LP rule $a < H'$ holds good. We could also consider Adv as repeatable (i.e. Advⁿ*) in a structure like

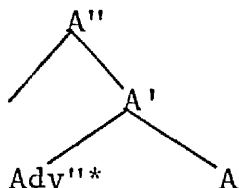

where any number of Spec can occur, subject to the LP rule $[+Q] < [-Q]$. But, mainly on evidence based on adjectives in NP, we adopt the first alternative, even at the cost of having no means to ensure that $[+Q]$ precedes $[-Q]$ (because the above LP rule works only for sisters (cf. 3.2.2)).

It is worth pointing out that *too* as a specifier of A' and as a specifier of Advⁿ (structures a, d p.60,62) $[-Q]$ parallels the occurrence $[+Q]$ of *so* as a specifier of adjectives and quantifiers in English (cf. structures of p.53), with the difference that what appears to be an unusual subcategorization possibility (cf. p.52) for the English adjectives, is just the rule in M G. Jackendoff invokes either a generalization of the Specifier Constraint, or semantic means for eliminating the unnecessary combinations that would emerge if Aⁿ in the second structure or A' in the first (p.53) expanded in Degⁿ or Qⁿ respectively. "Combinations of quantifiers and degree words as independent constituents... are not needed" (Jack.1977:146, note 2). In terms of our theory, such combinations are excluded according to the $[\pm Q]$ feature of *too* (structure f p.67) and the Specifier Constraint.

Independently of this, one could argue that our

claim about collapsing Q and A into a single category is false. I do not think that the existence of two different words *toso* is sufficient to justify the maintenance of a distinct category Q. The crucial fact is that both classes of A./Adv. (i.e. - or +[Q]) can have a *toso* in their upper specifier position. Thus, the rule for A" applies with complete generality, so that an additional rule like:

Q"[Deg" Q']

seems unnecessary.

A' [+Q] is not a recursive node¹⁷. It is only if it carries the feature [+comp] as well (cf. 2.2.2.2). The same is true of Adv' [+Q +comp]. The characteristic comparative morpheme is *pyo*. We did not assign to it the category Deg, because it can be preceded by *toso* - i.e. these two cannot be in complementary distribution. *Pyo*, like *toso*, is a specifier of [+Q] adjectives or adverbs. In effect, it is a specifier of the adjective in general:

- 51. a. *Pyo omorfos*
- b. *Pyo polis*

Due to its recursiveness, we can get such complex things as:

- 52. *Toso poli pyo poli poli omorfos*
 [so much [more much [much beautiful]]]

Like *toso*, I also assumed that *pyo* is + or -Q depending on whether it is followed by the [+Q] *poli* -. The following rule accounts for the occurrence of *pyo* in adverbs and adjectives.

$$\left[\begin{array}{c} A' \\ +comp \\ \alpha Q \end{array} \right] \left[\begin{array}{c} Adv'' \\ +comp \\ \beta Q \end{array} \right] \left[\begin{array}{c} A' \\ \alpha Q \end{array} \right]^{18}$$

[+Comp] is a foot feature of A'. There is a tendency for *pyo* to generalize over NP as well (cf. notes 11 and 14).

Another feature of the adjective is [+sup(erlative)] - in complementary distribution with the feature [+comp]. It is realized either as Adv'' [+Q+sup] branching directly from A', or as an Adv'' [+sup] branching from Adv' [+Q]. In the former case it is a foot feature of A'' and it comes down as the adverb *elakhista* (very little), or as a whole set of adverbs, which, without being quantificational in the sense that *arketa*, *katholu*, *endelos*, *kaboso* etc. are, have the semantic effect of designating the maximum degree of the property which the adjective expresses. These adverbs, which are also called 'intensifiers', include *apistefta*, *ekpliktika*, *apithana*, *katapliktika* (unbelievably, amazingly etc.). In the latter case it is a foot feature of Adv'' [+Q], and through it of A''; the above adverbs branch now from Adv' [+Q] and include also the superlative *poli*, which is distinct from the quantificational *poli* by virtue of just its participation in this class of adverbs marked as [+sup]. By doing this, we have exactly the same structures for [+comp] and [+sup] adjectives - the difference resting upon the different features. Of course, there is a difficulty with the further expansion of the [+sup] adverbs. It is true that they do not expand freely, e.g.:

53. *

| | | | | | | |
|---|------------|---|---|------------|---|---------|
| { | arketa | } | { | ipervolika | } | omorfos |
| | ekpliktika | | | apithana | | |
| | toso | | | | | |
| | poli | | | | | |

Following Jackendoff, I assume that, syntactically, all the relevant positions in Adv" [+sup] are free to expand. But since both - Adv"[+sup] and its quantificational or degree modifiers - "have the semantic effect of designating a degree, there are semantic reasons for their non-cooccurrence. We may invoke a principle similar to the Specifier Constraint;... "(Jack. 1977:166-7 note 6).

There is, finally, another adverb with an idiosyncratic property; this is *para*, which exclusively precedes *poli* [+Q] or [+sup] - and is the leftmost constituent in the specifier system of adjectives. It could be a [+sup] adverb, but since the deg *toso(s)* and *para* appear to be in complementary distribution, it seems preferable to assign it to the category Deg with the feature [+pol-] which guarantees that *para* can come out exclusively as a degree specifier of the adverb *poli* or the adjective (*polis*); cf.:

- 54.a. Para poli omorfos
- b. Para polis kafes
- c. Para pola vivlia
- d. Para poli pyo omorfos
- e. Para poli perisotero omorfos
- f. *Para toso (poli) omorfos
- g. *Toso para poli omorfos

I would like to stress that what has been so far said about superlative adjectives concerns only what is traditionally called the 'absolute' superlative degree of adjectives. This type of superlative adjective is not followed by *any* sort of complement.

We have, thus, seen that a very small set of simple and general rules together with the right use of the appropriate features suffice to account for the

apparently complicated system of NP specifiers.

2.3 Measure Phrases

2.3.1 Measure Phrases in Jackendoff's X'-Syntax

In Jackendoff's X'-Syntax measure phrases are NPs which occur in the X'' specifier position of all major categories, providing another significant cross-category generalization. In that position they alternate with QPs. The following examples illustrate this:

- 55. a. Two feet long (in A'')
- b. Five miles down the road (in P'')
- c. Charlie told Edna the story three times (in V'')
- d. { An inch of rope
Two parts glue } (in N'') .

Selkirk (1977) presents arguments for the specifier status of the NPs in d. above. It is characteristic that no article follows *of* (*two feet of the rope* has the partitive structure (see III.B), in which *of the rope* is in the N' complement). Again, with respect to d, it is maintained that there are two uses of measure phrases in the specifier of the NP. The second example of d. is used only in predicate positions (after *be*, *seem*, *stay*, etc.) e.g. *This mixture is two parts alcohol and three parts water*. The evidence for attaching measure phrases in N'' is first that they precede adjectives, which are in N'' (**ordinary two gallons of water*) - thus being in N''' or N'' - and, second, that they do not receive the possessive morpheme which is *invariably* attached to N''' in the N''' Specifier (e.g. *John's book* etc...., but

*an inch's of rope) (cf. also p. 42). Schematically, a measure phrase is given in the following configuration.

$$[X''N''' \dots X']$$

It is crucial that the measure phrase "consist of a *quantified count noun*" (emphasis mine), "with further selectional restrictions on the noun depending on the nature of the X' of which it is a sister" (Jack. 1977:139).

2.3.2 Measure phrases as prehead modifiers of the modern Greek NP

We shall have the chance to deal more extensively with the interesting properties and distribution of measure phrases in MG in the corresponding section of the next chapter (III.A), for measure phrases participate in the so-called 'pseudopartitive' construction. Measure phrases also bear certain striking similarities to the items called 'classifiers'. Here we shall confine ourselves to making some rather general comments about the position of measure phrases as specifiers of *A* and *N*. Consider the following examples:

56. a. O Yanis ine *dhyo metra* psilos
the John is two metres tall
John is two metres tall
- b. I eklisia ine *pende khilyometra* makria
The church is five kilometres far away
- c. Ipye *tria bukalya* krasi
drank-3rd s. three bottles wine

- d. *Apotelite apo ena meros nero ke dhyo (meri) alevri*
consist -3rd s. of one part water and two(parts) flour

We see that the underlined phrases in 56 are prehead specifiers of adjective in *a*, adverb in *b*, noun in *c* and *d*. These 'quantity indicators' (as Bresnan (1973) calls them) occur in VP and PP too, but we shall not be concerned with these here. The first thing we observe in c-d is that, unlike the corresponding cases of English, no 'formative' similar to *of* is inserted to distinguish measure phrases in predicate position from those in all other positions within the NP.

2.3.2.1 The position of Measure Phrases in the NP

As has been already mentioned, Selkirk claims that these measure phrases are modifiers of the head noun and not themselves the head, and that the absence of a definite article after them is crucial in establishing the noun that follows them as the head noun and not as a partitive complement. We shall see that her remarks are basically valid for corresponding NPs in MG, in the relevant chapter, but now it suffices to cite examples like the following for it to become clear that these measure phrases are specifiers:

57. *Aghorasa tria buketa iakinthus*
bought-I three bunches hyacinths
58. *Mnya anthodhezmi iakinthi*
 {*iakinthus}
one bunch(nom) hyacinths(nom)/*hyacinths(accum)
59. *Idha tria zmini pelarghus*
 {*pelaryi}
saw-I three swarms (acc.) cranes (accum)/cranes(nom)

Throughout 57-59 we see the application of the universal principle of agreement of the specifier elements with the head noun. Thus, in 57 the phrase *tria buketa* is in the accusative agreeing with the object of the verb (*iakinthus*). The same in 58 and 59. If the head noun is in the nominative, its specifier must also be in the nominative, if it is in the accusative, its specifier must be in the accusative. For, if *anthodhezmi* in 58 was the head noun, there would be nothing in principle to prevent *iakinthus*, as its complement, (complements, in general, are not *required* to agree with the head noun in the relevant syntactic features), to be in the accusative - as it is in the starred version. But the specifier status of measure phrases is also evident from 56a and 57. We cannot say that *metra* is the head since nouns do not take adjectives as their complements. Examples 56c-d and 57-59 are instances of the syntactic phenomenon called *parathesis* ('apposition') by traditional grammar. In this use, the term *parathesis* reflects the fact illustrated above: two consecutive NPs declined in the same case. The peculiarity of this construction, if compared to the corresponding construction in English, is due to the simple fact that MG has still a declensional system, besides the fact that a 'preposition', like *of*, is absent here. Phenomena of verb agreement will force us later on to consider strings like 56c-d and 57-59 as in fact ambiguous between a so-called 'pseudopartitive' reading where the measure phrase is a specifier, and a noun complement ('consistive') reading where the 'measure' phrase (no more measuring) is the head noun, and the noun following it its complement. But for the time being we are dealing exclusively with the first reading - the 'pseudopartitive'. Where, then, are these phrases attached as NP specifiers ?

According to what has been said so far, these

measure phrases have a function very similar to that of quantifiers like *poli*, or of quantificational articles like *arketi* etc., in the sense that they express a quantity or degree of some entity. As such, then, are they specifiers in N'' (like *arketi*, *meriki* etc.) or in N' (like *poli liyi* etc) ? We saw that Jackendoff places them in his N'' (our N'), first because the possessive morpheme is attached only to specifiers of N''' - and such measure phrases are never possessive - and second because their complementary distribution with ordinary quantifiers in N'' can be easily accounted for by the use of feature matrices. Thus, both NPs and QPs are [+Subj.-Obj.-Det], the [+Comp] feature being their only difference.

With regard to MG measure phrases, in principle we can attach them to either position - N'' or N'. The strongest argument for placing them in our N'' is the fact that these measure phrases cannot be preceded by the definite article, unlike *polis* and *lighos* which can (strings like *to ena potiri nero* have a different structure (cf. III.A). Being in complementary distribution, measure phrases and articles are, then, mutually excluded. Of course, one might counterargue that the former can be still in N', and a feature [-def] on the higher NP(N'') can further guarantee the absence of the definite article in the case of measure phrases, but not of the other adjectives + or -Q which occupy the same position. But this feature would still leave the possibility of the [+Q] adjectives and measure phrases being preceded by any article marked as [+Q] in our grammar (see pp.48-49); of course this difficulty can be overcome by the application of the specifier constraint, which will block:

- 60.a. *Enas polis kafes (but: o polis kafes)
 a much coffee (the much coffee)
- b. *Ena ena potiri nero
 a one glass water

Nevertheless this solution seems to me rather complicated and *ad hoc*. Since measure phrases are in some way inherently indefinite, exactly like *kanenas*, *enas*, *meriki* etc. I assume that they are in N'', sharing this position with ordinary indefinite articles, which are [+Q] as we suggested earlier¹⁹ (p. 48). Given the feature [+Q] for measure phrases, as well as their position under N'', we reach the interesting generalization that all [+Q] categories in N'' (articles and nouns - i.e. measure phrases) are indefinite, the definite article being the only [-Q] category in N'' (see p. 49).

The rule for the expansion of N'' will, accordingly, be:

$$\left[\begin{array}{l} N'' \\ \alpha \text{ def} \\ \beta \quad Q \end{array} \right] \left\{ \left[\begin{array}{l} \text{Art} \\ \alpha \text{ def} \\ \beta \quad Q \end{array} \right] N' \right. \\ \left. \left[\begin{array}{l} N'' \\ \alpha \text{ def} \\ \beta \quad Q \end{array} \right] \right\}$$

Or, more simply:

$$\left[\begin{array}{l} N'' \\ [-\text{def}] \end{array} \right] \left\{ \left[\begin{array}{l} \text{Art} \\ [+Q] \end{array} \right] N' \right. \\ \left. \left[\begin{array}{l} N'' \\ [+Q] \end{array} \right] \right\}$$

where [-def] is a foot feature, as already said. We should note, however, that generalizations are not expressed in the rules themselves but by means of meta-grammatical statements, such as feature co-occurrence restrictions (cf. p. 49). We could, for more simplicity, omit the [+Q] feature under the N'' specifier categories

and consider again [-def] as a foot feature - since, anyway, it is stipulated that the only N'' specifier of N'' is necessarily [+Q] (see also III A 2.1); furthermore, the definite article, which is [-Q], will be automatically excluded by the feature [-def]. We arrive thus at:

$$\begin{array}{c} N'' \\ [-def] \end{array} \left[\begin{array}{c} \{ \text{Art} \\ N'' \} \\ [-def] \end{array} N' \right]$$

Even if we used the feature system of Jackendoff's, articles and nouns are both [+Subj -Obj]; nouns are unspecified with respect to the feature Det, their differentiating feature being [+Comp].

The co-occurrence of measure phrases in N'' and of other [+Q] adjectives in N' will be correctly blocked by the Specifier Constraint; cf:

61. a.* Tria buketa poli iakinthi
 three bunches many hyacinths
- b.* Ena potiri poli nero
 one glass much water

Now, what has just been assumed - namely the [+Q] feature of measure phrases - must be further justified. First, we can point out that measure phrases constitute - in parallel to other [+Q] categories - answers to questions introduced by *poso* (how much), i.e. quantificational questions: *poso nero ipyes simera ? - Tria potirya / kaboso/poli* (-'How much water did you drink today'? - 'One glass' 'enough'/much'). Second, we must recall Jackendoff's definition, according to which a measure phrase consists of a *quantified* noun (cf. p.93 above). This becomes clear in the following examples:

62. a.* Potiri nero
b. Kanena } potiri nero
 { Ena
c. Tria } potirya nero
 { Pola
d.* Potirya nero
63. a.* Aghorasa anthodhezmi yakinthus
b. " mnya " "

Since a measure or quantity phrase has as its primary function to specify a quantity of something, a *glass* (*potiri*) by itself cannot do this. Thus, a quantifier like *pola*, or a numeral like *tria* is needed. This (62b) lends more support to the assumption (cf. note 19) that the indefinite article is [+Q] (see p.48). These facts refer to the expansion of the measure phrase itself. With respect to this expansion it is worth mentioning Akmajian and Lehrer's view, that certain Qs are clearly NPs since they can be assigned several of the characteristics of nouns; namely they can take determiners, numerical modifiers, and can also appear in singular or plural. On the other hand, the authors continue, 'true quantifiers' (quotations mine) fail all these characteristics. This fact suggests that some Qs have been historically derived from Ns or NPs, and that new Qs are from the class of *measure and unit nouns* (emphasis mine). Now, the feature [-def] under the upper NP will allow only for strings like 62b,c,d, 63, as well as 64:

64. Arketa potirya nero

while excluding:

- 65.a.*Ta potirya nero
 the glasses water
- b.*Aghorasa tin anthodhezmi iakinthus
 bought-I the bunch hyacinths

c.* Ta dhyo metra psilos
the two metres tall

d.* Ta pende khilyometra makria apo dho
the five kilometres away from here

Notice that the feature [-def] on the specifier N'' must be still a foot feature ascending from the Art of this N'' by FFP. By this left-branching of the feature [-def] not only do we capture the inherent indefiniteness of measure phrases, but we also see that despite the fact that measure phrases involve ordinary nouns, these cannot expand freely. This has been also noticed by Akmajian and Lehrer (1976) in the light of corresponding facts in English²⁰, who assumed that "NP-like Qs (i.e. 'measure phrases') form a restricted subset of the full set of possible NPs in English" (p. 411).

The quantifier - like status of measure phrases represented by the feature [+Q] is on line with the principle concerning classifiers, which we shall cite here in anticipation of our discussion to follow on the parallelism between classifiers (of classifier languages) and measure phrases: "A classifier concatenates with a quantifier, locative... or predicate to form a nexus that cannot be interrupted by the noun it classifies" (Allan 1977:288). So, a numeral or a quantifier is necessarily combined with - for example - *potiri* so as to form a measure phrase (p. 99). It is in this sense that the feature [+Q] is assigned to N'' in the N'' specifier position. In effect, this means that the only N'' specifiers of N' are [+Q] - i.e. measure phrases. It must be assumed that the feature [+Q] ascends on to N'' (the measure phrase) from its specifier by the FFP (see III A.2.1). Of course, "further selectional restrictions on the noun depending on the nature of the X' to which the measure phrase is a

sister" (Jack. 1977:139) will block odd strings like 66:

66. a.* Ena potiri pelaryi

b.* Ena zminos nero

We shall see later that these 'selectional restrictions' follow from the function of certain nouns (those participating in measure phrases) as classifiers (see III A2.1.1). As a final point in favour of the quantifier-like status of measure phrases we can cite the following examples:

67. a. Plithos yinekes yemisan tin aghora

crowd women filled the market

The market was inundated by crowds of women.

b. Sori ta rodhakina apulita stin aghora !

heaps the unsold peaches at the market.!

The unsold peaches at the markets form heaps !

The fact that the unit/measure nouns *plithos* and *soros* have lost some of their basic properties as nouns - namely they can hardly be preceded by quantificational adjectives or numerals :

68. ??_{Pola} plithi yinekes,
Tria

while they can occur 'bare' (e.g. 67a), unlike the nouns appearing in 62 (cf. 62a and d, 63a), - as well as the fact that some of the measure/unit nouns can be predicatively used and emphatically stressed, much like the [+Q] adjectives and articles *polis*, *arketos* etc.-cf. *plithos* and *sori* in 67a-b - show that certain of these nouns are gradually shifting from the category of nouns to that of [+Q], so that the semantic parallelism between *poli*

or *arketi anthropi* and *plithos anthropi* is more striking. In exactly the same connection we observe that the noun *soros* (heap, pile) has changed its gender in certain environments - from masculine to neuter - perhaps to parallel the neuter *plithos*, cf.:

69. Ena soro yinekes
one heap(=many) women

in parallel with

70. Enas soros yinekes ,

where *soros* appears in its 'original' gender, being however of a more restricted use than *soro* in 69.

Here we could refer again to Akmajian and Lehrer's similar conclusion that nouns and noun phrases being converted into Q (cf. p. 99) lose some of the flexibility they had as 'full' nouns, e.g.:

70. a. Thirty is a round number
b. A round number of people attended the lecture

Thus, some nouns seem to constitute a transitional stage in their way towards being fully 'quantifier-like', while other nouns are at the same time exactly like quantifiers.

2.3.3 The position of Measure Phrases in Adjective Phrases

What we have said so far about the quantifier-like status of measure phrases within NPs holds for measure phrases as specifiers of adjectives and adverbs too. Cf. the question by which we are interested in *how tall* someone is:

71. a. Poso psilos ine o Yanis ?
how tall is the John ?

b.- Dhio metra !
two metres !

- Poli
much

- Arketa
enough

- Katholu
not at all

What we should mention in the case of measure phrases as adjectival specifiers, is that here, too, 'further selectional restrictions' will determine the exact adjective that is modified (cf. p. 93) by a certain measure phrase. In this connection we can notice that certain strings are clearly bad, e.g.

72. a. *Tria metra kondos
three metres short

b.* Dhio kila elafris
two kilos light

c.??Tria kila varis
three kilos heavy

d.*?Ena metro stenos
one metre narrow

It has been observed (cf. Bresnan 1973, Lees 1961) that measure phrases may occur only before one of a special group of quantifiable adjectives, such as *tall*, *wide*, *deep* etc. but not before other adjectives, like 'privative' ones (as *short*, *narrow* etc. are)²¹. Notice that the

answer to a question similar to 71a, which involves the adjective *stenos* (narrow) is odd/bad.

73. a. Poso steno ine ?
how narrow is-3rd s.
How narrow is it ?

b.*?Ena metro
One metre

It seems that a measure phrase in front of a privative adjective (although *varis* (heavy) is not 'privative') is in some way redundant - or, conversely, that the privative adjective after a measure phrase is redundant or contradictory. One could notice related phenomena, such as the lack in the lexicon of nouns derived from privative adjectives - cf. *fardhis* (wide)/*fardhos* (width) but *stenos* (narrow)/- ? - and the consequent absence of expressions like 74

74. Ekhi tria metra fardhos
has-3rd s. three metres width
It is three metres width

e.g. 75.a. Ekhi tria metra *sten-?
has-3rds.three metres ('narrowness')

b. Ekhi ena metro *kond-?
has-3rd s. one metre ('shortness')

But these facts involve semantic considerations and will not concern us more. What we must do now is attach measure phrases - whenever they are allowed to appear - within AP. Given that they are in N'' in NPs, as we argued, they must be in the corresponding position within AP, i.e. in A''. This is justified because measure phrases

and Deg [+Q] are mutually excluded:

76. * { Toso } pende metra makris
 { Arketa }
 * { That } five metres long
 { Enough }

The specifier constraint is, then, operative in prohibiting the co-occurrence of a measure phrase and a [+Q] adverb (which is in A'), like *poli*, *ligho* etc.:

77. * Pende metra poli psilos
 * Five metres much tall

2.3.3.1 Measure Phrases in the expansion of *toso* and *pyo*

We meet with some unexpected difficulties with regard to the appearance of measure phrases before *tosos* in NP and *toso* in AP and the comparative adjective, cf.:

78. a. Dhyo fores tosa (lefta)
 Two times as much money
 b. Dhyo fores { pyo pola lefta }
 { pyo omorfos }
 two times { more much money }
 { more beautiful }

It appears then that measure phrases are specifiers of the category Deg, as well as of Adv[±Q +Comp]. But they are specifiers of Deg[+Q] only, not of Deg[-Q]; cf.:

79. Khilyes fores $\left\{ \begin{array}{l} \text{toso omorfos} \\ \text{tosa lefta} \\ \text{?? toso } \left\{ \begin{array}{l} \text{poli omorfos} \\ \text{pola lefta} \end{array} \right\} \end{array} \right\}$

This complicates things considerably, for generally, measure phrases do not specify [+Q] constituents (adjectives or adverbs):

80. *Poles fores $\left\{ \begin{array}{l} \text{pola} \\ \text{poli} \\ \text{ligho} \end{array} \right\}$
 many times $\left\{ \begin{array}{l} \text{many} \\ \text{much (very)} \\ \text{little} \end{array} \right\}$

80 cannot be easily ruled out, since the specifier constraint is not operative here (cf. 77 p.105). Anyway, the relevant rule for this expansion of Deg" is

$$\text{Deg}'' \left[\begin{array}{l} \text{N}'' \\ \text{+Q} \end{array} \right] \text{Deg}'$$

But this does not account for the occurrence of measure phrases in *pyo/perisotero*. Another complication concerning the above rule is that, unlike in English, the Deg" specifier position is not shared by Adv" [+Q] and N" [+Q], but only by N" [+Q], whereas in AP and NP both [+Q] constituents are candidates for the corresponding position. Moreover, there is no straightforward way to explain the low acceptability of the ?? version of 79, apart, perhaps, from just claiming that measure phrases appear as specifiers of Deg only when this is [+Q] (cf. p. 67, structure f). Then, the above rule must be revised so as to contain the feature [+Q] under Deg, although this

is very *ad hoc*.

As for measure phrases in front of a comparative adjective, it appears that in this case we get even more lack of generality. First of all, *toso* and measure phrases do not co-occur in this environment:

| | | | | |
|---------|---------|-------|------|---------------------------------|
| 81. a * | Khilyes | fores | toso | perisoteros |
| a' * | " | " | " | omorfoteros |
| b * | " | " | " | pyo polis |
| b' * | " | " | " | omorfos |
| c * | " | " | " | pyo poli { 'lighos } omorfos |

The only explanation I can offer, which will also be in accordance with what has been concluded so far, is that since *pyo* and *perisotero(s)* ^{are} [+Q], *toso* is [-Q], therefore the rule of p. 106 cannot apply. However, this leaves a', b', c still unexplained, since we have assumed that *toso* here is [+Q]. Of course, semantically, the reason for the ungrammaticality of 81a-c is rather obvious. The degree adverbial *toso* determines the extent to which someone is *more* x than someone else; but the phrase *Khilyes fores* (a thousand times) does exactly the same; consequently *Khilyes fores* and *toso* together are redundant as specifiers of the comparative adjective - one of them suffices (cf. *Poso omorfoteros* ? *Khilyes fores* or *toso omorfoteros*...). But how can we block their co-occurrence in terms of the structures we drew on previous pages ? One possible way seems to be simply the fact that measure phrases and *toso* share the same position in front of (comparative) adjectives. The problem is how to account for the appearance of a measure phrase in A" [+comp], especially when it is marked as [+Q] - cf. p. 105 and 106. A relevant rule can be:

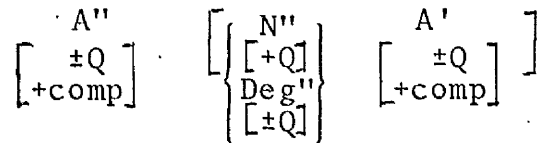

The only rule to which this can be related is the general one by which adjectives and adverbs are expanded as the sequence measure phrase +Ad(j.-v). Since we have already said that selectional restrictions determine the choice of the measure phrase according to the nature of the modified A, [+comp] may be considered as a feature of a particular class of A requiring a particular type of measure phrase. In short, the only obvious generalization is that measure phrases appear as specifiers of X', X representing N, A(djjective-dverb), Degree, as well as PP and VP - but we haven't touched on PP and VP here.

As a final note, we must mention another curious fact concerning examples like 79 on the one hand, and 78b on the other. Once *toso* (or *tosos*) is specified by a measure phrase, it cannot be followed by the degree clauses which it normally takes as its complement, cf.:

82. *Khilyes fores tosa lefta $\left\{ \begin{array}{l} \text{osa ...} \\ \text{pu ...} \\ \text{oste ...} \end{array} \right\}$ (an ikha)...

a thousand times so (much) money $\left\{ \begin{array}{l} \text{as ...} \\ \text{that...} \\ \text{so as...} \end{array} \right\}$ (if had-I).

This is natural, because the complement degree clause which follows *tosos* performs the same function as the phrase *khilyes fores*, which precedes it. Both make concrete, define accurately, the notion of quantity expressed by *tosos*; cf.:

83. a. -Posa lefta an ikhes... ?

b. $\left\{ \begin{array}{l} \text{-Osa mu edhines} \\ \text{-Khilyes fores tosa...} \end{array} \right\}$

(*tosa* is, of course, anaphoric). On the other hand, a measure phrase in front of a comparative adjective does not prevent the comparative complement from appearing - naturally - since the latter is not quantificational.

84. Khilyes fores omorfoteri apo ti mitera tis!
A thousand times more beautiful than her mother!

2.3.4 Summary

In this paragraph we have considered the function and position of measure phrases within NP and AP. We claimed that their function is quantificational, consequently the feature [+Q] is appropriate for them. As such, measure phrases are specifiers of N' - in parallel to the other [+Q] articles. Similarly, they are in A'' in parallel to the degree *toso* or the [+Q] adverbs *katholu*, *kaboso* etc. Furthermore, a measure phrase is a specifier of *toso*, therefore its appearance generalizes over the category 'degree' as well. There is a difficulty with the occurrence of a measure phrase as a specifier of the comparative adverbs *pyo*, *perisotero*, or of the corresponding quantificational comparative adjective. Since measure phrases do not modify simple [+Q] adjectives or adverbs, we are led to assume that their occurrence in comparative adjectives/adverbs is exclusively due to the feature [+comp] assigned to the latter, and can be considered as a further consequence of the recursiveness of the [+comp] categories in general. Further research is needed for the formulation of the exact rules that will account for all the occurrences of measure phrases in AP.

3. Adjectives as modifiers of N'

(A discussion on the position of prenominal and postnominal adjectives)

In what follows I shall discuss some interesting aspects of the position and syntactic function of adjectives. Some emphasis will be given to the problem of the 'definite' adjective before or after the NP, e.g.:

O mathitis o ikanos
the student the efficient

O ikanos o mathitis
the efficient the student
The efficient student

A tentative proposal will be made, namely that adjectives occurring after the head noun be considered as complements in both indefinite and definite NPs. The following Appendix on Nominal Apposition, which will also be the 'transition' to the next chapter of NP-complements, will form a basis for formulating this proposal systematically and place post-head adjectives in their proper place in the overall complement system of the MG NP.

3.1 A short history of the syntactic account of prenominal adjectives

3.1.1 The derivation of prenominal adjectives in the (early) transformational framework

Prenominal adjectives in English, like those in 1-2 below

1. A *good* child
2. The *clever* student

were long considered (cf. Lees 1960, Smith 1964, Chomsky 1965, Bach 1974) to be the result of an ordered set of rules, so-called 'Whiz Deletion', or, 'less picturequely' (Huddleston 1976) Relative Clause Reduction, and Adjective Shift. This derivation is shown in 3.

3. a. $\left. \begin{array}{l} A \\ \text{The} \end{array} \right\}$ girl who is pretty
b.* The girl pretty
c. The pretty girl

Adjective Shift cannot apply when the modified noun is an indefinite pronoun, e.g.:

4. Someone nice ,

or when the adjective left after RCR contains a complement of some sort, e.g.

5. A man fond of animals

This account of prenominal adjectives is claimed (Huddleston 1976) to prevail over an account which would maintain a PS rule like NP → Det Adj. N, since the latter would fail to show that the relation between *pretty* and *girl* is the same as in the simple sentence *The girl is pretty*. Generally, the transformational derivation of prenominal adjectives was justified on three grounds: a. The parallelism of semantic interpretation. b. The parallelism of selectional restrictions. c. Simplicity (cf. Sussex 1974). It should also be stressed along these lines that the transformational derivation of modifiers in general from RRCs had the alleged advantage of relating in a systematic way pairs of phrases like:

6. a. The house that is on the left
b. The house on the left
7. a. The train that is rapidly approaching
b. The rapidly approaching train
8. a. The man that is seeing Sally
b. The man seeing Sally
9. a. An elephant that was bigger than a house
b. An elephant bigger than a house

It appears that a whole set of complements has a common source: restrictive relatives. Thus, the Relative Clause Reduction is claimed to be a well motivated rule. Nevertheless, Adjective Shift, as a special rule which 'repositions' (Bach 1974) *some* modifiers (emphasis mine) appears to have a rather *ad hoc* character. Thus, quoting Bach, G. Lakoff has pointed out that modifiers can be preposed just in case the last element is Verb or Adjective and is directly dominated by the highest V (or S) in the relevant NP. Thus, compare these phrases with those above:

10. a.* The on the left house
b.* The seeing Sally man
c.* A bigger than a house elephant"

(Bach 1974:272). The *ad hoc* character of Adjective Shift is reinforced, I think, given the additional restriction of the character of the modified noun (cf. example 4).

3.1.1.1 Bolinger's counterevidence

However, as early as 1967, Bolinger showed effectively that even the traditional relative clause-

transformation fails to account for many if not most instances of attributive adjectives "...since there is a clear functional difference between predicative modification and attributive modification" (p. 1)²². So, there are many attributive adjectives that can never be predicative:

- 11. a.* The reason is main
- b.* The stranger is total

and others that are in an obvious relationship to predications of other kinds, e.g.

- 12. A daily newspaper~The newspaper appears daily

In short, Bolinger presents evidence that confirms the existence of "a set meaning for pre-adjunct adjectives, called 'characterization'" (Bol. 1967:7). This semantic entity is borne out by the restrictions some attributives and predicatives have. Thus, 'temporariness' is a feature opposed to 'characterization', and for this reason its presence constitutes an obstacle to an adjective occupying attributive prenominal position:

- 13. a. The man is ready
- b. * The ready man
- 14. a. Dented bells
- b. * Rung bells
- 15. a. The girl was faint
- b. * The faint girl

However, "there is no obvious measure for how temporary a 'temporary' adjective must be for attributive position

to reject it" (ibid p. 10). Consequently "a temporary modifier becomes normal if the situation is such that nouns are distinguished by it. The phrase *The then president* is about as far as English has gone in permitting temporal adverbs to be used attributively. But *The now president* is impossible." Similarly, "a nearby building but not a nearby man, since a man can move off the next moment" (ibid p.11). Examples like *My friend is close* vs *my close friend* reveal the familiar change of meaning. Of the class of adjectives with the prefix *a-*, which are restricted to predicative and posthead position "both by their adverbial origin and by their sense of temporariness" (ibid p. 12), e.g. *a house afire, a man asleep* etc., "some are gradually edging their way to attributive position" (ibid.), e.g. *a sensitive and aware audience*. Likewise, *away games* contrast with *home games*. Along the same line Bolinger points out that adjectives with their own complements are excluded from attributive position, although their synonyms are not:

16. a. The man was loth to speak
- b.* The loth man
- c. The unwilling man

(cf. also Quirk-Greenbaum 1973:123-124 : "Adjectives that are restricted to predicative position.... tend to refer to a (possibly temporary) condition rather than to characterize.... A larger group comprises adjectives that can or must take complementation.... Many closely resemble verbs semantically: *He is afraid to do it - He fears to do it*. Some have homonyms that can occur both predicatively and attributively, e.g. *The conscious patient - the patient is conscious*"). In Quirk and Greenbaum (1973) we find exactly the same observations and

claims with regard to the dichotomy permanent/temporal; cf: "Modification in noun-phrase structure may also be seen as permanent or temporary, such that items placed in premodification position are given the linguistic status of permanent or at any rate characteristic features. Although this does not mean that postmodification position is committed to either temporariness or permanence, those adjectives which cannot premodify have a notably temporary reference. Thus *the man is ready* would be understood as having reference only to a specific time and this corresponds to the non-occurrence of **The ready man...* Just as some modifiers are too much identified with temporary status to appear in pre-head position, so there can be modification constrained to pre-head position because it indicates permanent status. Compare *original* in *the original version* and *his work is quite original...*" (Quirk-Greenbaum 1973:277). Also "... our decision to use an item as a premodifier often reflects our wish that it be taken for granted and not be interpreted as a specific identifier" (ibid.). There is a whole set of adjectives that can only be attributively used, lacking altogether a predicative equivalent. These are 'nominal' adjectives, called 'complex nominals' by J. Levi (1973, 1974) (cf. Simeónides (1981) for a detailed discussion of these adjectives in MG) shown in NPs like *school bus*, *mining engineer*, *theatrical criticism*, *country/traffic rural policeman*, *criminal lawyer* etc. Levi has proposed that these be derived from underlying nouns, since they keep the properties of nouns in surface structure. Whatever they are, they are excluded from predicative position:

17. * The engineer (who) is mining
- * The bus (which) is school
- * The policeman (who) is rural

Cf. also Bolinger (1967:15)" predications, since they modify the referent rather than the reference of the noun, thus turn out to be unsatisfactory sources for many attributive adjectives." Bolinger's account of prenominal adjectives comprises two methods of generation: one called *reference-modification*, being in the 'kernel' (cf. "what is generated in the kernel is not a list of adjectives but a reference-modifying slot, occupied by adjectives some of which are free to appear in the predicate, others not, but all of which when in attributive position become modifiers of the reference system of the noun, not any particular referent directly... The reference system grips the attributive adjective more tightly than the predicative adjective" (Bol. 1967:18), cf. also p.115 above), the other, called *referent-modification*, originates "in a way of predication which is joined by conjunction rather than by subordination" (ibid p. 1)²³.

Finally, R. Sussex (1974) points out the deficiencies of the successive derivation by RC Reduction and Adj-Shift on the grounds "of the asymmetrical distribution of order-slots, in pre- and post-nominal attributive position, and in relative clauses"²⁴ (p. 127). Sussex considers qualitative adjectives (like *nice*) as lexical primes - i.e. not derived from RCs. Relational adjectives (like *wooden*) "must be derived from underlying relatives" (p. 125), and the same is true of modals that do not originate from predicative RCs - like *former*; cf. "... the existence of /-PRED/modals neither destroys TG at its source nor poses a problem for the principle of deriving adjectives from relative clauses and T_{ADJ}-fronting" (ibid), which, as we saw, is Bolinger's (1967) view as well.

3.1.2 Prenominal A as N'' specifiers within (Jackendoff's) X' Syntax

However, this method of derivation of prenominal asjectives in English was formally challenged by Chomsky (1970) and was basically abandoned within the general framework of the Lexicalist Hypothesis²⁵. Chomsky (1970: 196) discusses a whole class of modifiers which cannot be reduced underlying restrictive relatives:

18. a. The weather *in England*
- b. The story of *Bill's exploits*
- c. The author of *the book*
- d. Prolegomena to *any future metaphysics*

(cf. also Delorme-Dougherty 1972:27).

The view that prenominal adjectives are generated by a phrase-structure rule has become common place (cf. Culicover 1976). So, within X¹-Syntax, as formulated and established by Jackendoff (1977), adjectives are definitively the product of the PS rule:

19. N'' → (A''')*-N'...

Cf.: "a base-generated prenominal adjective is semantically as adequate as any other source" (Jack. 1977:178). Adjectives as such are restrictive modifiers, like restrictive relative clauses and prepositional N'' complements, since they, too, satisfy a *constraint* (see Jackendoff 1977:176) on the use of the definite article:

20. He greeted me with {the} usual warmth
 {*a}
- {an} unusual warmth
 {*the}

and, moreover, they determine the choice of the proper article. The adjectives in 20 cannot, obviously, be derived by reduction of a RC²⁶.

The semantic function that N' and restrictive modifiers (its 'sisters') have is the classificatory one (cf. Jackendoff 1977:194). In terms of logic "all the classificatory functions have been represented as predicates" (ibid); i.e. "each classificatory constituent has been supplied with an 'X is' and placed in the restriction on the variable controlled by the operator" (ibid.), where by operators we mean the quantifiers and the definite article; e.g.:

21. a. The picture of Bill from London fell down
- b. fall down (λX is a picture of Bill, x is from London)

3.1.3 Two 'problems'

Two final notes should be made before we close this brief introduction on the history of the treatment and derivation of adjectives in generative grammar. The one concerns adjectival modification of proper nouns. The other the ambiguity between a restrictive and a non-restrictive reading of prenominal adjectives.

3.1.3.1 Adjectival modification of proper names

Normally, proper names cannot take restrictive relatives (and modifiers, generally). cf.:

22. * John that came to dinner....

(Jack. 1977, Chomsky 1965), but can, of course, take

appositives:

23. John, who came to dinner,...

In the light of this fact, Jackendoff suggests that *poor* in *poor John* is not a restrictive modifier, since it does not constrain the choice of possible referents of the phrase, "rather something more akin to the projection rule for appositives must integrate *poor* into the interpretation of *poor John*" (Jack. 1977:181) (cf. also Chomsky 1965: "... adjective modifiers derived from nonrestrictive relatives like *clever Hans, old Tom*", p. 217).

But proper names can in certain cases have restrictive relatives²⁷. Chomsky (1965) suggests that "such expressions may be derived from proper nouns with nonrestrictive relatives by transformation" (p. 217). But Jackendoff (1977) shows that such expressions reveal another generalization, namely that a certain class of restrictive modifiers (APs, PPs, RRCs) permits the use of the definite article with proper names, cf.:

- 24. a. The old Paris
- b. The Paris of the 30s
- c. The Paris I love

(Recall that APs, PPs and RRCs can all be interpreted as restrictive modifiers). Thus, the conclusion is that modifiers of proper nouns have two different origins: if the proper noun is preceded by the definite article the prehead or posthead modification is restrictive (in N" in Jackendoff's system); if the noun does not have the definite article, the prenominal adjective must be considered as a non-restrictive modification parallel to an appositive RC.

3.1.3.2 The restrictive/non-restrictive ambiguity of prenominal adjectives

The above facts concerning proper nouns reveal - at its extreme, i.e. in its clearest aspect - the ambiguity of adjectives between a restrictive and a non-restrictive reading. This issue was discussed in the Port-Royal Logic in Jespersen ('Philosophy of Grammar', London, 1924), and was pointed out by Chomsky (1965) ('adjective modifiers can be derived from either restrictive or non-restrictive relatives - cf. the ambiguity of the sentence "the industrious Chinese dominate the economy of Southeast Asia" (p. 217)). Cf. also Sussex(1974) "From the semantic point of view, the transformational analysis is convincingly supported by the fact that ADJ-N and N-ADJ sequences normally carry the same restrictive/non-restrictive interpretations as the corresponding relative clauses:

The genuine chair is here

The chair, which is genuine, is here (APPOSITIVE)

The chair which is genuine is here (RESTRICTIVE)

The only exceptions seem to be fixed ADJ-N compounds like *purchasing power*" (p. 124). (With regard to this last remark cf. Levi 1973, 74 and Simeonides 1981). It seems that there are certain conditions under which adjectives may be interpreted as restrictive or non-restrictive modifiers - these conditions constitute the topic of separate and detailed study. However, Jackendoff's grammar does not provide the means for such a differentiation of prenominal adjectives (unless as modifiers of proper names). As restrictive modifiers they are excluded from a non-restrictive reading. Cf. on this Sussex' comment in note 25 as well as:

"... the Lexicalist Hypothesis can handle EITHER the subject/ object , or the restrictive/non-restrictive distinctions in adjective ordering, but not both - unless, that is, both problems are dealt with in the semantic component" (ibid. p. 128).

3.1.3.3 Summary

In this paragraph we have briefly considered the syntactic account of prenominal adjectives, starting from the early transformational framework till the Lexicalist Hypothesis and Jackendoff's version of X²-Syntax, where prenominal adjectives are the product of the PS rule expanding N".

In the following paragraph we shall consider cases of adjectival modification in MG, and propose an account for both prenominal and postnominal adjectives within the GPSG, where, by definition, transformations are excluded.

3.2 Adjectival modification in MG

Cases of adjectival modification that will concern us here are shown in the following examples (cf. also p.110):

25. a. Idha ena oreo vivlio
saw-I a nice book

b. Idha ena vivlio oreo
saw-I a book nice

26. a. I mera i kali apo to proi fenete
the day the good from the morning looks-3rd s.

- b. I kali i mera apo to proi fenete
the good the day from the morning looks-3rd s.
The good day is apparent from the morning

27.a. O pistos filous
The faithful friend

- b.* O filous pistos
* The friend faithful

We shall discuss the problem raised by 25b and 27b on the one hand, and the evidence provided by 26a-b on the other. We shall offer a tentative analysis for both 25-27(a) and 25b; 26b.

3.2.1 The problem: what are adjectival strings occurring after the head noun ?

More accurately, the problem mentioned is derived from the basic principle of the grammar we employ here, namely that all specifier elements precede their heads. This principle in Jackendoff's phrase structure grammar is shown in the following rule schema:

$$X^n \rightarrow (C_1) \dots (C_j) \dots X^{n-1} \dots (C_{j+1}) \dots (C_k)$$

where X^{n-1} is the lexical head (1977:53).

Within the framework of GPSG this is expressed by the following LP rule:

28. a < H'

To demonstrate the validity of this principle in MG, we can cite the following examples in which articles (cf.

p.48) come after the noun:

29. *Vivlia {ta
 {merika}
 *Books {the
 {several}

and refer back to 27b, in which the prenominal adjective *pistos* appears postnominally. But then why in 25b *can* the adjective appear after the head ? Is that a violation of the above mentioned principle or can it be explained in some other way ? And if it is a violation of 28, why in 27b is this violation not possible ? Is there a real asymmetry between definite and indefinite NPs when they contain an adjective ? Finally, what is the adjectival unit article+adjective in front or after the NP in 26a-b?

3.2.2 The position of prenominal adjectives

In order to justify the label 'adjectival' for restrictive relatives (p.260) we cite examples where an adjective, a RR and a PP serve exactly the same purpose, that of restricting the referent of the modified noun (cf. "... the head can be viewed as a member of a class which can be linguistically identified only through the modification (restrictive) that has been supplied" (Quirk-Greenbaum 1973:376)). Independently of whether or not prenominal adjectives are ambiguous between a restrictive and a non-restrictive interpretation, I assume that adjectives as restrictive modifiers are in prenominal N' position (corresponding to Jackendoff's N''), which corresponds to the postnominal N' position, to which we shall claim (p.355) that RRCs belong. Of course both modifiers can exist in an NP:

30. {To } oreo forema pu idha khthes...
Ena
the nice dress that saw-I yesterday...
{ a }

Notice, incidentally, that such examples suggest that, although in MG stacked restrictive relatives are not a common phenomenon (cf. p.268) two different restrictive modifiers are quite usual, so that the restriction on the occurrence of stacked relatives must be due to extralinguistic reasons (ease of perception etc.) rather than to syntactic ones.

Now, because of the fact that we can get in principle an infinite number of adjectives before a noun, e.g.:

31. a. Ena omorfo xilino tetraghono trapezi
A nice wooden square table
b. Pola orea mikra pragmata
Many nice little things
c. I fanatiki orghanomeni athlites
The fanatical organized athletes

we must assume that N' is a recursive node. Recursiveness of N' will give us a structure like 32.

32.

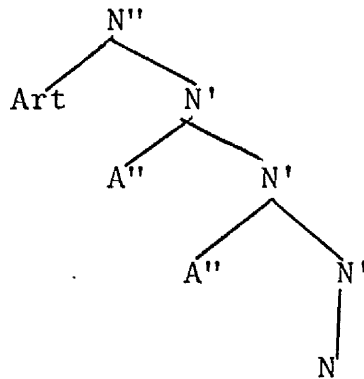

We also might assume that A'' is simply repeatable as in N' [A''*N^(')]. But patterns of ellipsis confirm the existence of N' nodes: this is very clear in English, shown in the *one(s)* pronominalization process; cf. *John bought a new nice green car, and his father bought an old one (or an old awful one or an old awful red one)*. In corresponding cases of MG we get an empty head, as an anaphoric process; cf. *I Maria aghorase ena akrivo moderno forema, eno eggho aghorasa mono ena ftino/ or ena akrivo palyomodhitiko* (Mary bought an expensive modern dress, whereas I bought just a cheap (*one*) / or an expensive old fashioned (*one*)). Here we also get an elliptical pattern but instead of the anaphoric *one(s)* there is an empty head, which makes the whole elliptical phrase resemble to what Jackendoff calls 'N'-Anaphora construction '-a construction resulting from 'substantivization' (see Jackendoff 1977:114-117). Details aside, recursiveness of N', at least in the case of pronominal adjectives, seems well justified in MG as well as in English (cf. Culicover 1977). However, given this recursiveness of N', we are not in a position to account for the fact that [+Q] adjectives always precede [-Q] ones. Remember we claimed (p.43-44) that *polis* is an A'' [+Q], and that A'' [+Q] are also in N'. Example 31b as well as 31d below:

31. d. *Orea pola mikra praghmata

show that quantificational adjectives precede all other adjectives. To account for this, we could postulate the LP rule 33:

33. [+Q]'' < H' ,

which, however, does not work in the above given structure (cf. II 2.2.4).

We further notice that prenominal adjectives can be eventually conjoined to *pu* relatives as well as to PPs, cf.:

34. a. Enas sinepis ke pu xeri na meleta mathitis...
a consistent and that knows to study student..
A student consistent and one who knows how
to study...
- b. Enas sinepis ke me arkhes anthropos
a consistent and with principles man

34a-b, while posing some problems concerning the position of restrictive relatives²⁸, shows that prehead adjectives, PPs and RCs must have something in common. which allows their conjoinability. For a grammar comprising a transformational derivation of adjectives from RCs, 34a would be no problem since adjectives are RCs at some stage of their derivation. However this would be less so for 34b, since such PPs are unlikely to be reduced RCs (cf.: Jackendoff 1977, Chomsky 1970), cf.:

34. c. *Enas anthropos pu ine me arkhes.

In our grammar we must find some other way to account for these cases of conjunction. One such way could be the use of features. Thus, adjectives and RCs are both [+V] (cf. p. 19), or, in terms of the feature system incorporated in Jackendoff's syntax they are [-Subj+Comp], unspecified for Det, differing only in the feature Obj (As are [-Obj]), Vs are [+Obj]). Adjectives and PPs are more difficult to account for by a common feature notation: in the Chomskyan (1970) feature system As are [+N+V] and Ps are [-N-V]. On the other hand in Jackendoff's

system they both are [+Comp+Subj], unspecified for Det, differing only in the feature [-Obj] (Ps are [+Obj]). In this respect they can be conjoined.

3.2.3 Posthead adjectives are complements of N'

Since we do not want to relax the principle represented in 28, in the light of examples such as 25b and 26_a, we propose that adjectives appearing after the modified noun, as in 25b, are complements. This complement position (the N') is independently needed and justified: It is the position of restrictive relatives as well as of certain PPs and genitive (possessive) complements. Cf. the parallelism between:

35. O loghos { [pu] exafanistike }
 { [ya ton opio] } }
 [tis exafanisis tu]

the reason { [that] disappeared-3rd s. }
 { [for which] } }
 { (of)-the disappearance (of)-his }

So, there is in principle nothing to prevent adjectives from occurring in the complement position. Such a view lends some additional support to the claim that adjectives and restrictive relatives both function as restrictive modifiers in the same way. Notice that in a transformational analysis this step (a posthead adjective) constitutes an intermediate step between RC reduction and A-Shift -ungrammatical, generally, in English (although, even so, it would have to be considered as a complement) but absolutely grammatical, and common, in MG -.

- Cf.: 36. a. Enas anthropos axiologhos
a man remarkable
- b. Ena vivlio endhyaferon
a book interesting
- c. Pedhya provlimatika
children problematical

3.2.3.1 Justification for our claim

Bolinger's evidence against a transformational relationship between prenominal and postnominal adjectives is equally valid for corresponding cases in MG. Thus, we reject a metarule* (of the type: 'for each rule that generates an adjective after the head, there is a rule that generates a prenominal adjective'), for there is no one-to-one correspondence between the two adjectives; more accurately, not every adjective can occur in the complement position, while the reverse very often implies a change of meaning. To confirm this, we cite the following examples:

37. Mnya theatriki kritiki
a theatrical criticism
** Mnya kritiki theatriki
38. Meriki katastrofi
partial disaster
* Katastrofi meriki
39. Anikhto panepistimio
Open university
* Panepistimio anikhto

*Of course, this is for the sake of argument only, because it is impossible to write such a metarule in principle, for in the latest version of GPSG metarules operate only on lexical ID rules (cf. p. 17).

40. Atomiki vomva
Atomic bomb
* Vomva atomiki
41. 'Eleftheros tipos' (title of a newspaper)
'free press'
*'Tipos eleftheros'

The following example is a case of ambiguity and change of meaning, i.e. the adjective *xipnyo* after the head in 42

42. Ena pedhi xipnyo
a child awake/clever

is ambiguous between *awake* (not sleeping) and *clever*, but the prenominal in 42a

42. a. Ena xipnyo pedhi

means unambiguously a *clever* child. Similarly in *enas anthropos asinithistos*, *asinithistos* means not used to something (it usually requires a prepositional complement), whereas *enas asinithistos anthropos* means an unusual, strange person. Examples 37-42 are only some examples of a very common phenomenon. This 'asymmetrical' distribution of adjectives can be very well explained in terms of Bolinger's (1967) analysis of adjectives. Here I confine myself to stressing the existence of the phenomenon, and to concluding that the statement of any sort of formal (syntactic) connection between the two instances of adjectives would also involve the task of stating the conditions under which a 'free interchange' can take place. Since the grammar provides us with two

positions, one specifier and one complement position, we are free to exploit both of them, if the facts allow us to do so. It is worth pointing out the remark that "modification at its most restrictive tends to come after the head; that is our decision to use an item as a pre-modifier (such as *silly* in *The silly boy got lost*) often reflects our wish that it be taken for granted and not be interpreted as a specific identifier. Secondly, restrictive modification tends to be given more prosodic emphasis than the head" (Quirk-Greenbaum 1973:377). Along this line, it can be explained why the NPs in 37-41 are felt and claimed to be 'units' with 'a fixed order of their constituent parts' (Simeonides 1981:215); Cf. also Tzartanos (1946:72) "the adjective is without emphasis when it occurs between the article and the noun". These remarks about the prenominal adjective tie up nicely with Bolinger's ones about the requirement of the category that occupies the prenominal position to be 'characterizing' (cf. p.113), which implies a permanent (i.e. not 'temporary') - 'characteristic'-attribution; cf. "the great majority of predications are not transportable to attributive position.... This restriction confirms the existence of a set of pre-adjunct adjectives which I have called 'characterization'" (Bol. 1967:6-7). In the light of these we can explain why certain categories, other than adjectives, occur in prenominal position. Cf. note 28, example 34a-b and the following:

43. Enas *khoris pira* dhikighoros (cf. *apiro*s dhikighoros)
a without experience lawyer (cf. unexperienced lawyer)

44. Mnya *me kali anatrofi* kopela
a 'with good breeding girl
(cf. *mnya kaloanathremeni* kopela, a well-bred girl).

45. *Ena khoris filoma dhendro*
a without foliage tree
(cf. *afilo dhendro*)

46. *O me prosonda ipalilos*
the with qualifications employee

The underlined PPs in 43-46 appear also as postnominal complements. Now, notice that the PPs in the following examples cannot appear prenominally:

47. ?? *O me yalya andras*
the with glasses man

48. ?? *Ta me fruta ghlika*
the with fruits ghlika

49. a. *O andras me ta yalya*
The man with the glasses

b. *Ta ghlika me fruta*
The sweets with fruits (made of fruits)

All the above examples show that a PP in order to occupy the prenominal position²⁹ must express a permanent characteristic of the referent of the noun, an inherent characteristic, as it were, or something that can be 'taken for granted' and not as a particular identifier.

I think that the extreme case of this characteristic attribution is shown in phrases like

50. *O kato kozmos (= o Adhis)*
The lower world (=Hades)

51. *O exo elinizmos (=o apodhimos elinizmos)*
The outer Greek world

52. Ta eos to 1843 yeghonota
the-till-the-1843 events

in which the adverbial preceding the head noun and the head noun itself give us a unique referent. Although we get:

50. a. O Kozmos kato

52. a. Ta yeghonota eos to 1843

these have different implications from the corresponding 50 and 52. For example, *o kozmos kato* is not 'Hades' and *o elinizmos exo* is hardly acceptable.

In 50a and 52a (as well as in *o elinizmos exo*) the PP is a complement and is in fact more emphatic than when it appears preminally. It is interpreted as a 'specific identifier'. We thus see that adjectives, adverbial phrases and prepositional phrases (secondarily only RCs cf. note 28), as well as certain genitival NPs, e.g.

53. a. Mhya *mikru mikus* tenia
a (of)-short length film
A short film
a'. Mhya tenia *mikru mikus*
b. Mhya *anef proighumenu* peripetia
a without precedent adventure
An unprecedented adventure
b'. Mhya peripetia *anef proighumenu*

(but

- c. Enas *asteras tu kinimatoghrafu*
a star (of)- the cinema
c'.*Enas tu kinimatoghrafu *asteras*)

obey the same restrictions on when they can occupy the prenominal position³⁰. We shall see that nouns can be also used as prenominal attributives, as well as post-nominal complements, obeying the same restrictions as those mentioned earlier³¹.

As a final remark on the fact that prenominal adjectives express some permanent characteristic of the head noun, consequently that these are considered as forming a unique entity, I cite examples in which the function of the attributive modifier (usually performed by an adjective) is undertaken by a noun, the head itself being a semantically 'empty' noun (such as *anthropos*), since the semantic 'load' is carried by the modifier, cf.:

54. a. Papas anthropos
 priest man
 Priest
- b. Dhaskalos anthropos
 teacher man
 Teacher

As becomes clear from the English translation, the modifier alone suffices to denote the meaning of the whole phrase (cf. note 46).

We can conclude that the fact that certain categories other than adjectives can also occur in prenominal position (given that they satisfy the necessary requirement of attribution) may confirm not so much the independent existence of prenominal adjectives, but the existence of an 'attributive slot' (cf. Bol. 1967:8)³² which may be filled by APs, PPs, genitival NPs, and eventually by RCs. This fact can be represented by the LP rule 28, if α is assumed to stand for A'',P'',N'' [+gen]

3.2.3.2 Two questions

There are two questions concerning adjectival complements of nouns. The first is whether or not these must be 'derived' from restrictive relatives. The second concerns the 'level' to which these complements belong.

3.2.3.2.1 The relationship between restrictive relatives and adjectival complements

Although there does seem to be a relationship between postnominal adjectives and RRCs, as seen in the paraphrases of the following examples:

55. a. Enas anthropos endhyaferon
a man interesting
- b. Enas anthropos pu ine endhyaferon
a man that is interesting
56. a. Ena trapezi tetraghono
a table square
- b. Ena trapezi pu ine tetraghono
a table that is square³³

it seems preferable to assume that, given a complement position is independently motivated to accommodate RCs, PPs, genitive NPs, it also includes adjectival complements. It is worth pointing out that the relationship of the above complements (PPs, etc.) with restrictive relatives is disputable (cf. Jackendoff 1977), e.g.:

57. a. Enas kirios me yalya
a gentleman with glasses
- b.* Enas kirios pu ine me yalya
a gentleman that is with glasses
58. a. I musiki tis epokhiz mu
the music (of)-the era (of)-mine
The music of my era
- b.* I musiki pu {ine } tis epokhiz mu
{itan }
the music that {is } (of)-the era (of)-mine
{was }

It seems that other predications - not just *be* ones - are the 'sources' of the above examples (e.g. *enas kirios pu fora yalya*). Accordingly, in the LP rule

$$H' < \alpha < V'' [+R]$$

α stands for PPs, genitive NPs and APs.

3.2.3.2.2 The position of adjectival complements within the NP

We have so far assumed that (restrictive) adjectival complements are complements of N'. This is a reasonable assumption, since restrictive relatives are also complements of N' (cf. chapter IV, 4). And not only restrictive relatives, but other restrictive complements as well. Furthermore, we also claimed that prenominal adjectives are N' specifiers and we cited examples 35, 43-46, 50-52 to show the correspondence between different categories of restrictive modifiers (specifiers and

complements)* (cf. also note 30). Here it is worth recalling Jackendoff's claim "in N' the complements include PPs.... and (for semantic reasons their prehead position notwithstanding) APs" (Jack. 1977:72-73). But given that restrictive complements are under N', we must account for their relative order. Thus, we modify the above LP rule as in

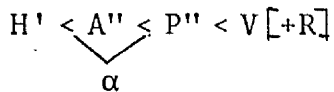

to account for the following examples:

59. a. Ena kustumi omorfo apo lino pu idhame khthes...
a costume nice from linen that saw-we yesterday
b. *Ena kustumi apo lino omorfo pu...

(read without a comma between the first two complements)

60. a. Enas anthropos sinepis me arkhes...
a man consistent with principles..
b.* Enas anthropos me arkhes sinepis³⁴ ...

3.2.4 A potential problem of our analysis

A final problem of adjectival complements concerns their agreement in all syntactic features with the

*Further support for this correspondence - the interrelationship of N' modifiers - is provided, I think, by the figure of speech traditionally called 'ek paralilu' ('parallel'). In this, the same (semantic) notion is expressed by two parallel modifiers, usually one prenominal and one postnominal; e.g. *sakatis anthropos m. ena mati* (cripple man with one eye). We have to assume that the prenominal adjective (*sakatis*) and the postnominal PP, since both have the same semantic function, are at the same level.

modified head noun - since complements, unlike specifiers, are not required to agree with their head. Intuitively, we can only say that since adjectives are an inflectional category in Greek, they always agree with some noun. Thus, even in complement position they agree with the modified noun - i.e. if the noun is masculine, nominative, singular, there is no reason why the complement adjective should be feminine, accusative, plural. Probably, the Control Agreement Principle accounts for this sort of language-particular agreement, which is also explicit in the post-head demonstratives (as e.g. *o anthropos aftos*) (cf. note 49). Nevertheless, it is worth stressing that it is not the complement position that requires this agreement. So, if instead of an adjective there is a noun in that position (cf. below p.163), this noun *may not* agree in gender and number, although it must agree in case, with the head; for example:

61. Anthropos thirio
man monster

62. Ena spiti palati
a house palace
A house (like?) a palace.

Posthead adjectives like that in 25b may be considered as [α case] complement. But we shall discuss such complements (i.e. 'appositional') below.

3.2.5 A consequence of our analysis of adjectives

To come now to the fact that adjectives always follow 'indefinite pronouns' (cf. Smith 1964), besides offering additional support to our assumption that the latter are in fact specifiers (i.e. articles) of nouns, it follows automatically from our previous discussion

on adjectival positions. We only need assume an empty head noun. Cf. the following structures :

a.

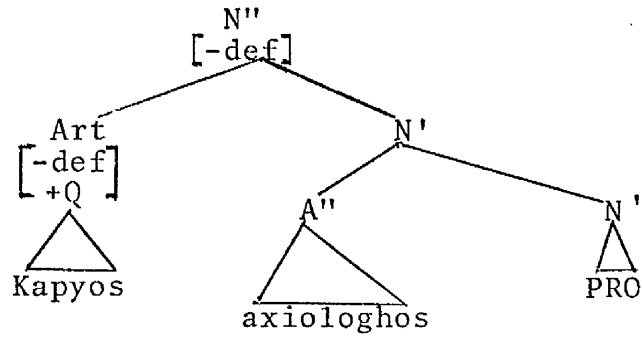

b.

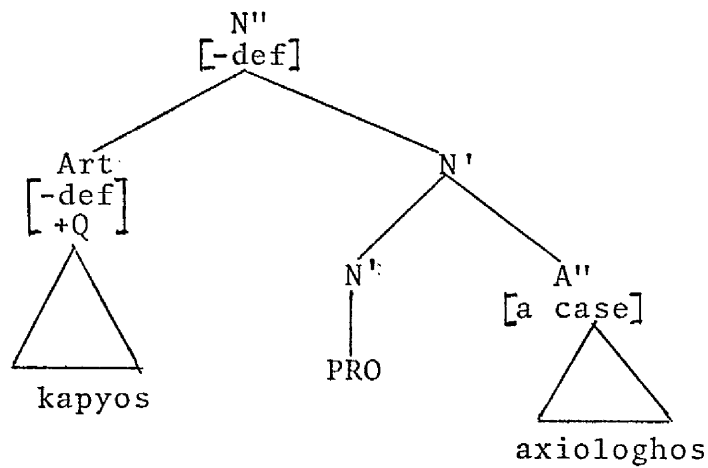

Thus strings like

- a. Kapyos axiologhos milise
 someone remarkable spoke
- a'.*Axiloghos kapyos milise
- b. Mia omorfi emfanistike stis idhis
 a beautiful(girl) appeared at the news
- b'.*Omorfi mia . emfanistike stis idhis

do not constitute an idiosyncratic phenomenon, but they are accounted for easily by two combined assumptions,

first that the so-called indefinite pronouns are in fact articles (cf. p. 48), and, second, that the head noun does not contain lexical material. Thus, strings like the above are accounted for independently of whether the adjective is in prenominal or in postnominal position. We should stress that this NP with a PRO head is also needed in our grammar on independent grounds. Thus, it is the same configuration that appears in the partitive construction (cf. III, B.2) and in certain comparative complements - we shall also see that such an empty head may also explain the NP status of postnominal adjectival complements; finally we said that this supports the recursiveness of N'. It also appears in what is called 'N'-Anaphora' (e.g. *O Yanis dhyavase tria vivlia ky egho ena (kanena)/ to dhiko mu, tu Kosta*) and N'-Gapping (e.g. *i meleti tu Kosta ya ti ghlosa itan simantiki ala i dhiki mu ya tis sinepies tu kapnizmatos asimandi*) by Jackendoff (1977:116-117). More accurately, Jackendoff calls the process in all those cases which involve a PRO after N''' specifiers and which can be interpreted by certain projection rules 'substantivization'.

3.2.6 Definite (posthead) APs

With respect to 26a-b, I make the proposal that the occurrences of the 'definite' adjective here be considered as complements of the noun as well, the equivalent definite complement of the indefinite one we have so far discussed. 26a-b is another demonstration of a rather general principle, namely that definiteness in NPs refers to both the head and its complement NPs (unless these are generic) (cf. p.203). 27a-b reveals two inter-related facts: first that rule 28 is inviolable, and, second, that the adjectival complement must be definite

if the modified noun is definite, just like ordinary nominal complements.

3.2.6.1 Evidence for the complement status of postnominal adjectives

Supportive evidence for the assumption that the adjective in 26_n is a complement is provided by the fact that this, too, obeys the same restriction, as its indefinite counterpart, as far as its postnominal position is concerned. Thus, compare 63-67, parallel to 37-41:

- 63. a. I theatriki kritiki
b.* I kritiki i theatriki
- 64. a. I meriki katastrofi
b.* I katastrofi i meriki
- 65. a. To anikhto panepistimio
b.* To panepistimio to anikhto
- 66. a. I atomiki vomva
b.* I vomva i atomiki
- 67. a. 'O eleftheros tipos
b.* 'O tipos o eleftheros'

and in addition to these:

- 68. a. O kirios loghos
The main reason
b.* O loghos o kirios
- 69. a. I singekrimeni periptosi
the particular case
b.??I periptosi i singekrimeni

ekinos substitute for the *head* of the NP, *not* its complements, as it is clearly seen in 73, where the PP is definitely a complement. The same phenomenon shows up in indefinite NPs, only here the pronoun is, of course, indefinite:

74. Enas mathitis kalos ky enas metrioi
a student good and a mediocre
A good student and a mediocre one

We thus see that both the indefinite and definite adjectives follow the 'pronominalized' head as its complements. Now, the following examples show that, assuming article+adjective is a restrictive modifier in N', the relative order of complements in that position is the same as in indefinite NPs (cf. p.136)³⁵:

75. a. O mathitis o sinepis me tus kalus vathmus
the student the consistent with the good marks
The consistent student with the good marks.
b.*O mathitis me tus kaluz vathmus o sinepis
(read without comma between the two complements).

These can be conjoined - in any order:

76. a. O mathitis o sinepis ke me tus kaluz vathmus
b. O mathitis me tus kaluz vathmus ke o sinepis³⁶

Looking for constructions similar to 26a-b we find the following:

77. a. I adherfi mu to saini
the sister (of)-mine the clever (noun)
My clever sister

- b. O fititis o ipalilos
the student the employee
The student who is employeed
 - c. O Solomos o piitis
the Solomos the poet
 - d. I konserva to spanaki
the tin the spinach
The tin of spinach
 - e. To kuti ta spirta
the box the matches
The box of matches
- 78.a. Emis i kalitekhnes
we the artists
- b. Emis i eftikhismeni
we the happy (ones)
 - c. Oli i kathiyites
All the teachers
- 79.a. I Maria i Alexiou .
b. O Yorghos o Khristou

In 77a-e we get a definite head noun followed by another definite NP - its complement. In 78a-c we get a definite (personal) pronoun followed again by a definite noun (c) or an adjective (b), or an adjective-noun (a). In 79a-b we have a common way of stating peoples' first name and surname; the first name (definite) followed by the surname (also definite). All these constitute a type of noun complementation which the traditional syntax of MG groups together under the title *parathesis* ('apposition'). Anticipating the discussion to follow in the Appendix,

I only point out the fact that 'parathesis', as a special case of complements which agree obligatorily in case with the head (therefore marked as [~~a~~ case]complements), can account for this 'special' appearance of adjectives, which, then, are required by their nature to agree, additionally, in gender and number with the modified noun. Needless to say, the nominal complement of the head noun (cf. ex. 77a-e) cannot/is not required to agree with its head in any other feature but case. This is not an unimportant remark, for it enables us to treat phrases like 80a-b and 81a-b

80. a. Enas anthropos kalos
 a man good
 b. Enas anthropos therio
 a man monster
81. a. O anthropos o kalos
 b. O anthropos to therio

as forming a natural class, more accurately, as instances of apposition. Consequently, the same case of the adjective in 80-81 (a) is due to the particular type of complement it belongs to, and we can account for it by the feature [~~a~~ case] on both the head and its complement (i.e. its 'sister') (cf. p.150), according to the CAP (or to FFP), which is also responsible for their number and gender agreement. Thus, we assume that the definite adjective in 26a is a restrictive modifier; this, too, defines restrictively the extension of the modified noun. 27b, on the other hand, can be also seen as a violation of the requirement that the complement of a definite noun be definite as well (besides being considered as a violation of rule 28).

3.2.6.2 The nature of the definite adjectival complements

Now, it is exactly the definite article before the adjective in 26a-b that raises the problem of what exactly the string definite article plus adjective is. Since we do not have sufficient evidence to claim that adjectives can have their own article (we have seen that the position corresponding to Art is occupied by Deg in AP) we suggest tentatively that the definite article - adjective sequence be possibly considered as an NP with an empty head noun. Given that we are dealing with a case of apposition (cf. p. 157), we are obliged to accept this sequence as an NP - the majority of [a case] complements are NPs (cf. examples 77 and 78c). Supportive evidence for this assumption is provided by cases where we get such an 'adjectival' complement conjoined to a nominal (Free, cf. chapter IV B) relative:

82. I yineka i ikani ke opya xeri na frondizi
the woman the efficient and who(ever) knows
to look after
ton eafto tis
the self(of)-hers
The efficient woman and (the one) who knows
(how) to look after herself

Since the relative clauses introduced by the pronoun *opyos* are in effect noun phrases (cf. IV B) we are forced to consider the complements with which they are conjoined as noun phrases as well³⁷ (we should note here that *opya* modifies an understood head *yineka*). This conclusion is reinforced by cases where the adjective plus a definite article functions as an NP with a (understood) missing head noun, e.g. *o ftokhos (anthropos) (the poor (man))*,

o anoitos (anthropos) (the silly (man)).

(The extreme case of this phenomenon is the complete change of some of these article+adjective strings from the category of adjectives to that of nouns - cf. *i zoghrafiki (tekhní) (the painting (art))*, *i Eliniki (ghlosa) (the Greek (language))*, very often with a subsequent change of gender: *to imero* ('mild mood'), *to thanatiko* ('the plague'), *to podhariko* ('omen of good luck') (cf. Tzartanos 1946: 71)). Along this line consider the following question-answer examples:

83. a. - *Pyos mathitis ?* (Which student ?)

b. - *O ikanos*

the efficient

The efficient *one*

Here, too, we attest the correspondence in the pronomalization/substantivization process involving *one* in English but an empty head noun in MG (cf. pp.181,185); 83b as it stands, can be conjoined to a headed RC:

c. *O ikanos ke aftos pu xeri to simferon tu*
the efficient and that that knows the interest (of)-his

The efficient one and the one who knows
his interest

Since in c the second conjunct is an NP³⁸, we must consider the first conjunct as an NP, too.

It appears that the NP status of the 'definite' adjective gives it the freedom to move around the *basic* (definite) NP, hence 26b, where it is in front of the whole NP; cf. also:

84. a. O ikanos o mathitis
b. O erghazomenos o anthropos
the working the man
The working man

This is a property of other restrictive modifiers as well, when these, too, are definite, for example of the demonstratives *aftos/ekinos*, the quantificational adjective *olos* and (possessive) genitive NPs - all definite by their nature; cf.:

85. a. Aftos o anthropos
this the man
b. Oli i mathites
All the students
c. Tu Yani to vivlio
the John (gen) the book
John's book

Maybe, the fact that (definite) adjectives have this property is due to the identity of the two head nouns - the complement and the main noun. This freedom of movement of these definite complements must not be confused with the fact that certain restrictive modifiers (definite or indefinite) can appear either prenominal or postnominal under N' (as *sisters* of N') (see previous pages). Here we have a different situation where certain restrictive modifiers, when they are definite can also appear in front of the *whole* NP³⁹, i.e. preceding the article; I cannot propose formal means to account for this 'extra' appearance of restrictive modifiers in front of the definite NP; I make, however, the proposal that these 'fronted' complements be the result of topicalization or focalization -

namely that we have a slash type dependency in the N' complement position. Further research is required for the elaboration of this proposal.

3.2.7 Summary

So far we have maintained that prenominal adjectives are specifier elements occupying the attributive position within an NP, namely that they are N' specifiers as restrictive modifiers. The PS rule that generates them is

$$N' \rightarrow [A''^{(*)} N']$$

This can be modified in order to comprise other categories that can occur in the attributive prenominal position. These are PPs and genitive NPs (rarely adjectival relative clauses, too). This can be possibly represented in the above rule by the use of the common feature of those categories, which, in Jackendoff's (1977:33) feature system is [+Comp]. We thus have:

$$N' \left[\begin{array}{l} \left[\begin{array}{l} +Comp \quad NAP \\ \langle \pm Subj \rangle \quad N \\ \langle -Obj \rangle \quad A \end{array} \right]'' \\ \left[\begin{array}{l} -Subj \quad P \\ \langle \pm Obj \rangle \quad A \end{array} \right]'' \\ \left[\begin{array}{l} +Subj \\ +Obj \end{array} \right] \end{array} \right] N'$$

The fact that they always - as specifiers - precede their head noun is accounted for by the LP rule 28, repeated here:

$$a < H' .$$

Adjectives occurring after the head must be seen as

instances of NP Complementation. As restrictive modifiers they are complements of N', sharing this position along with restrictive relatives, [a case] nominal complements (with which they form the type of 'appositive' complementation), PPs and genitive NPs. In definite NPs it appears to be a requirement on the complement adjective that it be definite as well. As a consequence of that, we get apparently peculiar strings consisting of the definite article followed by an adjective. I suggest that these strings be considered as 'incomplete' NPs, i.e. NPs with a missing head that is identical to the lexical head of the modified NP. However, this suggestion is not free from difficulties, the most obvious one being that we are forced to consider corresponding 'indefinite' adjectives, like that in 25b, as NPs, too. Obviously, this is not so, as cases of coordination show (cf. note 37):

86. Enas anthropos kalos ke oso dhen fandazese timios
a man good and as much not imagine-2nds.
honest

A good and incredibly honest man

The second conjunct which is an adjectival free relative forces us to consider the first conjunct as an adjective - not an NP; cf.:

87. * Enas anthropos kalos ke opyos ine timios (cf. note 38)

Therefore, it seems that there is an asymmetrical syntactic behaviour between adjective complements in definite and indefinite NPs - in indefinite NPs the complement adjective is a real adjective, but in definite ones the definite adjective is in fact an NP (and an adjective?). I do not have an answer to this; I can only offer a means

of accounting for it. This involves again the use of features, as in the case of prenominal attributive categories. More accurately, As and Ns are both [+N] or, in Jackendoff's system, [+Comp-Obj]- they differ only in the feature [Subj.]. On the other hand, treating - at least 'definite' - adjectives in complement position as NPs, helps us to consider them as instances of apposition and explain the case agreement with the head noun in terms of this type of complementation. In the following Appendix we shall consider somewhat closer the phenomenon of apposition, which, in effect, is simply a particular type of complement of NPs marked as [α case].

The following tree-diagrams summarize what we have said so far about the position of adjectives:

a.

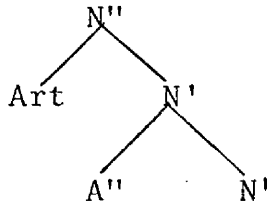

b.

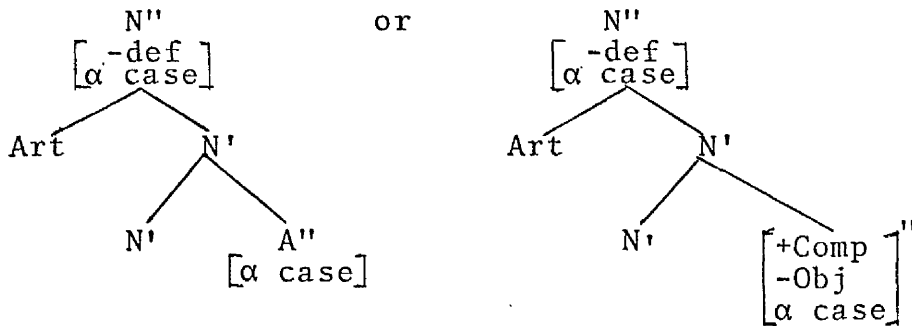

c.

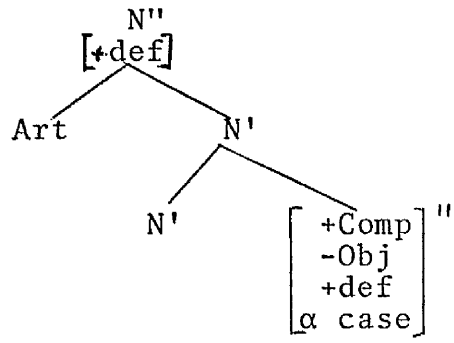

A P P E N D I X

NOMINAL APPPOSITION

0. Introduction

The following notes on Nominal Apposition are illuminating in two respects. First in the phenomenon of apposition we can observe an important generalization in English and in Greek, but this generalization is different in the two languages. For English, so-called 'apposition' is brought under the description of premodification. For Greek, on the other hand, it constitutes a type of complementation. We would like to present some justification for this. Second, the constructions which are called appositives in English, will give us the opportunity to discuss corresponding types of complements of NPs in MG in the next chapter.

1. The appositive construction in English

Apposition may be restrictive or non-restrictive. Non-restrictive apposition is shown in the following examples:

1. John, my best friend, visited me yesterday
2. He grasped the first thing he found, a piece of iron
3. His excuse, that he was ill, was a lie

Restrictive apposition is illustrated below:

4. The poet Burns
5. His friend John
6. The point zero
7. The term 'heavy water'
8. The claim that he was ill was not convincing.

Here we shall deal only with restrictive apposition. The properties and characteristics of nominal (restrictive) apposition, as expressed in various works are summarized as follows (cf. Burton 1975).

- a. The immediate constituents must belong to the same major class.
- b. The two (or more) units in apposition are constituents of the same level - i.e. none is more plausibly selected as head than the other. More generally, the NPs involved in apposition are neither coordinated nor subordinated to one another.
- c. The ICs must be identical in reference
- d. Each of the NPs can be separately omitted without affecting the acceptability of the resulting sentence.
- e. With relation to d, each of the NPs fulfills the same syntactic function in the resulting sentence.
- f. Again with relation to d, there is no difference between the original sentence and either of the resulting sentences in extralinguistic reference.

One more remark has been made with respect to a, namely that instances of close apposition invariably contain a proper name or "a noun with a similar force, a word or expression representing a thing as an individual not as a member of a class (e.g. the letter A, the figure 5)" (Burton 1975:393). From a-f above, the conclusion usually inferred is that the NPs in apposition are arbitrarily reversible.

It is along the above lines that E. Delorme and R. Dougherty (1972) analyse strings like *we men, you troops* etc, which, it is claimed, are in a natural class with *we, the men, you, the policemen* etc. Clearly, no

formal distinction is made between restrictive and non-restrictive apposition here.

1.1. The traditional derivation of appositive NPs

The traditional derivation of phrases like those in 4-8 has been from copulative RRCs, as in the case of prenominal adjectives. Accordingly, the NP *The poet Burns* is claimed to have the following derivation (cf. Burton 1975):

the poet the poet be Burns
the poet who is Burns
the poet Burns

1.2 Burton's account of appositive NPs

In her article 'Nominal Apposition' (1975), N. Burton tries to show that for examples like 4-6 there is no alternative to the derivation from relative clauses. But, she claims, there is an important difference between the derivation exemplified in 1.1 and her derivation which runs as follows:

Instead of the underlying form

the poet the poet be Burns

she proposes the alternative form

Burns Burns be poet

mainly because names as such cannot have an attributive function, for they always refer or imply a referent when they occur, but also because the intermediate stage

*the poet who is Burns

is ungrammatical⁴⁰. Thirdly, because if we apply the rule of Adjective Shift on *the poet Burns*, the result will be again ungrammatical:

*The Burns poet.

Thus, the alternative derivation is

| | | |
|---------------------------|-------------|-----------------------------------|
| [det] ⁴¹ Burns | [det] Burns | be poet |
| [det] Burns | WH | be poet (The Burns who is a poet) |
| The Burns | | poet (RC reduction, optional) |
| The poet Burns | | (A-Shift, obligatory). |

Clearly, by this derivation, the description of so-called 'apposition' is brought under the description of premodified nouns in general; the confusing point is that often proper nouns are involved in this type of construction. But then, the term 'apposition' itself, as conforming to a-f above is contradictory: relative clauses, by definition, are subordinated to their containing noun phrases. Consequently, criteria a-f are incompatible with the above derivation. Criterion α may be a rather accidental fact, a special case of nouns modified attributively by items that are of the category N rather than A. Criterion b is faulty. d,e,f cannot be true, at least not more than in the case of nouns modified by adjectives. Finally, c obviously has no validity, because sequences that contain coreferential NPs in restrictive apposition are ungrammatical:

9. *The Bard Shakespeare
10. *Linguistics the study of language
11. *Man Homo Sapiens

According to Burton's analysis, *poet*, *friend*, *point* in 4-6 play the role of adjectives - i.e. they function attributively - and no question of coreferentiality arises⁴².

It is further shown by Burton that examples like 4-6 are not arbitrarily (at random) reversible. Examples

- 4a. Burns the poet
- 5a. John my friend
- 6a. Zero the point

are not arbitrarily but transformationally related to 4,5,6 respectively, because while in 4,5,6 the modification may or may not have a contrastive function (cf. p. 115 and 130) in 4a,5a,6a it obviously has; i.e. 4a, 5a, 6a must be provided with a context within which the modification can be contrastive⁴³. The motivation for the transformation relating 4,5,6 to 4a,5a,6a on the one hand, and sentences containing proper names and adjectives on the other, such as:

- 12. The Great Peter
- 13. The ingenious Chomsky
- 12a. Peter the Great
- 13a. Chomsky the ingenious

is "that not only do we want to attribute greatness and being a poet to Peter and Burns respectively, but to identify them uniquely (or one aspect of them) by that attribute" (Burton 1975:402). In short, *Great* and *ingenious* in 12, 13 are attributive, but *the Great* and *the ingenious* in 12a, 13a are identificatory.

2. The apposition construction in traditional MG Grammar

In the 'Neoeliniki Syntaxis' of Tzartzanos (1946) apposition (we should stress that 'apposition' is used as a descriptive term for the juxtaposition of two constituents of the same category, and as such it must not be confused with apposition as a type of relative clause ; cf. p.159, and examples of pp.157-8 below) is defined as an instance of modification of nouns carried out by nouns. The crucial point is that the modifying nouns are of the same case as the modified ones. This modification is accomplished in parallel with adjectival modification. In short, nouns can be modified attributively by either nouns or adjectives. In that function, both adjectives and nouns are defined as 'same case' modifiers. I.e. adjectives and nouns are modifying elements required to agree with their head noun. The following examples are cited as instances of 'apposition':

14. I Mirsina i vasilisa
the Mirsina the queen
The queen Mirsina
15. Vyeni enas dhrakondas thirio
comes-out a dragon monster
A huge dragon is coming out
16. O Richardhos o Leonthimos, vasilyas tis
Anglias
the Richard the Lionheart, king (of)-the
England
Richard the Lionheart, king of England
17. I loghotekhnes khrisimopiun ena dhinato oplo,
ti mayia
the authors use a strong weapon,
the fascination

18. Zi sto khoryo Nea Artaki
lives-3rd s. in the village Nea Artaki
He lives at the village Nea Artaki
19. Eghnorise ti yineka thavma !
knew-3rd s. the woman miracle
He met the woman-miracle!
20. Egho I dhistikhizmeni !
I the unhappy (one)!
21. Emis, i katiki ton poleon
we, the inhabitants (of)-the cities
We, the inhabitants of cities
22. Ekini i kakomira
She the miserable !
23. Ena zevghari paputsya
a pair shoes
A pair of shoes
24. Ekatomiria erghates
millions workers
Millions of workers
25. Ena kilo sitari
a kilo wheat
A kilo of wheat
26. To puli to aidhoni
the bird the nightingale
The bird nightingale
27. Matyes enighmata
Glances - riddles.

First, we must mention that here, too, no distinction is drawn between restrictive and non-restrictive apposition. Since no distinction is made between restrictive-non-restrictive (appositive) relatives either, no confusion arises with regard to the label *apposition*⁴⁴. But 16,17, 21 are in any case instances of 'apposition proper', as it is called by N. Burton (1975), and we shall not deal with them. All other examples are instances of restrictive apposition (complementation) or, as we have already said, of [α case] complements. We shall consider them separately in the following chapter.

2.1 A criticism: our analysis

Leaving aside non-restrictive apposition, the way the above examples are classified and titled in the Tzartanos Syntax ('A. Nominal same - case modifiers: a. Substantives as same-case modifiers (apposition, exemplification') makes them parallel/equal to adjectival modification (cf. 'b. Adjectives as modifiers').

This is confusing for the following reasons. In the paragraph on adjectives it is stated that adjectives can appear in certain positions within an NP (e.g. between the article and the noun, after the noun, etc.). But nothing is said along this line about nominal modifiers. They appear invariably before or (usually) after the modified noun. Second, if nouns in the above examples function as (prenominal) adjectives, what is the function of sentential complements referred to among other nominal complements (Tzartanos:63)? Are those (attributive) modifiers as well? Third, among instances of apposition, adverbial apposition intervenes of the sort:

Eki epano
there up
Up there
Khthes proi
Yesterday morning
Etsi me klista ta matya
Like that, with closed eyes, etc.

Does the one adverb (the second, according to what is said on p. 62) modify the other attributively? How are these connected with nominal apposition ?

But there is another point which supports our analysis. This is a confusing overlap in the description of nominal and adjectival (attributive) modification. On p. 69 it is mentioned that the position and function of an adjective can also be undertaken by a *noun*. The examples that illustrate this do not differ from examples like 15 (p.157) as far as the position of the modifying constituent is concerned - but examples like 15 are claimed to be instances of 'parathesis', i.e. a distinct phenomenon. The same confusing overlap occurs when it is said of adjectives that they appear in front or after the definite noun, always accompanied by their own article. But the same is said in the section about apposition (Tzartzanos 1946:61), where such strings are described as appositive or exemplificatory modification. The only difference now is that the modified noun is a pronoun (cf. examples 20-22 p. 158 above). But is this difference of the modified category so important as to accept that adjectives occurring after them constitute a distinct syntactic phenomenon than when they occur after an ordinary noun ? Obviously not; after all "personal pronouns may be regarded as syntactically equivalent to nouns" (Lyons 1968:281). Furthermore, I shall present evidence

(see: III C) that examples like 19 are not an instance of apposition. The analysis we propose of all these cases of modification, despite minor problems it may still leave, systematizes by grouping together all the relevant phenomena. Nevertheless, apart from certain inconsistencies causing some confusion, traditional grammar is illuminating in this regard, in the way it groups together, as two inter-related sub-sections, nominal and adjectival modification under the general title 'Like-case modifiers' ('omioptoti prosdhiorismi'), and by calling nominal modification 'parathesis' ('apposition'), which is defined as 'nouns as like-case modifiers of nouns'. Given our previous discussion on adjectives and the above brief account of restrictive apposition in general, we can now present the central points of our proposals schematized as follows:

Table 1

| | MODIFIER | | | | HEAD NOUN | |
|---|-------------|-------------|------------------|---------------------------|---------------|---------------|
| | <u>Art.</u> | <u>Adj.</u> | <u>Adj. Noun</u> | <u>Noun</u> ⁴⁵ | <u>Common</u> | <u>Proper</u> |
| 1 | enas | kalos | | | anthropos | |
| 2 | o | | piitis | | | Solomos |
| 3 | enas | | kalitekhnis | | fotoghrafos | |
| 4 | | | | papas | anthropos | |
| 5 | | | | dhaskalos | " | |
| 6 | | | ghria | | yineka | |
| 7 | | | epistimonas ? | epistimonas ? | apateonas | |

Strings shown in this table demonstrate prenominal attributive modification. For these rule 28 is operative: the modifier - whatever it is - strictly precedes the head. Furthermore, the universal principle of agreement between all specifier elements and the head, accounted

for by CAP, applies to the strings of Table 1. This justifies the 'Adj.-Noun' and 'Noun' categories as indicated here. It cannot be accidental that the majority of nouns (though not all) that can occur prenominally are distinguished morphologically for gender, e.g. *o dhikighoros* (masc., the lawyer), *i dhikighorina* (fem.), *o piitis* (masc., poet), *i piitria* (fem.), *o vuleftis* (masc., deputy), *i vuleftina* (fem.), *o epistimonas* (masc., scientist), *i epistimonisa* (fem.) etc. There are, however, a few cases where a noun without any adjectival distinction of gender can also occur prenominally (*papas anthropos*, *palikari andras* etc.). These cases, though, are rather restricted, and usually an adjective (morphologically or otherwise) related to the noun replaces it (*yeneos andras*, *thirio pedhi/thiriodhes pedhi*). It seems that there is a morphophonemic process taking place whenever a noun tends to appear in prenominal attributive position. Thus, what we impressionistically indicated as Adj-N in Table 1 are items marked as $\begin{bmatrix} +N \\ \pm V \end{bmatrix}$ - i.e. N and A. This feature accounts for the ability of certain nouns (of course, not every noun can modify another noun attributively) to occur in prenominal position, hence, their agreement with the head noun. 'Plain' nouns, on the other hand, like *papas* (priest), *palikari* (brave young man) etc. are $\begin{bmatrix} -V \\ +N \end{bmatrix}$ ⁴⁶, and their occurrence is restricted, just because there is no room for the agreement principle to operate⁴⁷. Although strings in Table 1 are not called 'apposition' by traditional Greek grammar, we can justify Burton's claim that strings like *The poet Burns* - characterized as appositive by traditional English grammar - are indeed instances of prenominal modification involving proper names.

Table 2

| Head Noun | | [α case] COMPLEMENTS | | | | |
|-----------|---------------|----------------------|------|----------|---------------|---------|
| Art. | Noun | Pronoun | Art. | 'A' | Adj-N | N |
| 1 | spiti | | | | | palati |
| 2 | mthya yineka | | | | epistimonas | |
| 3 | | ekini | i | kakomira | | |
| 4 | o mathitis | | o | exipnos | | |
| 5 | i Maria | | to | | | xefteri |
| 6 | o Solomos | | o | | piitis | |
| 7 | o fotoghrafos | | o | | epangelmatias | |
| 8 | | aftos | o | eleinos | | |
| 9 | to kuti | | ta | | | spirta |

Table 2 shows that if the head noun is indefinite the complement must be indefinite too; if the head noun is definite the complement is definite, too. Here, obviously, the agreement required between head and complement is just case agreement-gender (and number) agreement is accidental. Our assumption that what appears to be a definite adjective is in fact a (definite) noun phrase with an empty head receives some support from the fact that all instances of complements in Table 2 are of the category N. If this assumption is not correct, we can, at least point out that the categories occurring as complements in this construction are moving gradually from $\begin{bmatrix} +N \\ +V \end{bmatrix}$ to $\begin{bmatrix} +N \\ -V \end{bmatrix}$ (i.e. adjectives, adjectival nouns, nouns).

The relationship between the head and the complement in Table 2 appears to be that of restrictive modification: we define restrictively the extension of the referent of the noun by making it a member of a particular set. Thus, we do not speak of any student, but of the student who is clever, as opposed to the non-clever student.

In the case of *o Solomos o piitis* particularly, the contrastive modification is even more clear. We are making a distinction between a man called Solomos who is a poet and a man called also Solomos but happens to be a painter, or whatever. The same relationship is found in the case of Greek proper names - first names and surnames:

- 28. I Maria i Alexiou
- 29. O Yanis o Khristou

In 28 a distinction is made between a girl called Maria having the particular surname (notice the gender agreement between the two articles in these cases, supporting our suggestion about an empty headed NP) and a girl with the same first name but of a different surname. Table 2 schematically comprises NP strings that are called apposition in English; some of them are also called appositive NPs in Greek. But we should note that whereas English examples are shown (Burton 1975)⁴⁸ to be cases of prenominal modification, corresponding Greek strings, like those of Table 2, are cases of nominal complementation. In section 3 of chapter II we discussed 'adjectival' complementation - i.e. cases like 2,4 and 7 of Table 2. In the next chapter we shall discuss cases like 1, and 9⁴⁹ (together with 5).

NOTES

1. There is, however, a recently developed type of expression showing that nouns are also modified by degree adverbials, which, naturally, do not impose any agreement condition on the head noun; these expressions belong rather exclusively to everyday speech and contain the adverb *poli* (much (of)) (rarely its semantic opposite *katholu*, not at all). They are mainly used as exclamatory expressions being emotionally 'loaded'; cf.:

- i. Ine poli anthropos!
is-3rd s. very(much) person!
He is a wonderful person!
- ii. Poli forema!
much/very dress!
Wonderful dress!

Although this type of expression is a violation of the universal constraint of agreement between the head and its specifier elements, it nevertheless reveals an interesting generalization: the occurrence of quantity adverbials in all major categories N, A, V (P?). It is worth noticing that in Spanish degree adverbials are common as noun specifiers (cf. Rivero 1980b).

2. The indefinite A[+Q] *Kati* (some, something) and *tipota* and the interrogative (adjectival) *ti* (what, of what kind), are indeclinable, although they precede nouns in all cases.

3. The same is true of English *many*, *few*, *some*. His many books (*His some books - *His books are some). There is a difficulty, though, with *arketos* and *kabosos*. They can be used predicatively, unlike *meriki*, but they

cannot be preceded by the definite article. However, even in this they somehow differ from *meriki*, since *i meriki* is entirely bad, whereas *i arketi/kabosi* are more precisely marked as ?*. Thus, it maybe that *arketos kabosos* are somewhere between the class of A [+Q] and that of Articles [+Q].

4. We could, of course, include the category A[+Q] in Art position and say that N'' expands as

$$N'' \left[\left\{ \begin{array}{c} A'' \\ [+Q] \\ Art'' \\ [\pm Q] \end{array} \right\} N' \right]$$

but the solution followed is, I believe, simpler and, anyway, close to the established rules illustrated in 1 (p.40). I also assume that our Art is decomposed into the feature matrix [+Subj -Obj. -Comp +Det].

5. In the case of *more* and *less*, spelling rules will yield the correct form *more* (from *more-much*), *less* (from *more little*), *further* (*more far*), *taller* (*more, tall*).

6. The need for the QP to be treated as a single constituent is seen in its behaviour regarding the movement rule of 'QP-Shift', but this does not concern us here.

7. Jackendoff too attaches such specifier items like *practically, quite, nearly, just* etc. in X'''. Cf. "some of these are patently adverbs, and in NPs are replaced by their adjectival parallels" (cf. *Mary is clever, Mary acted cleverly*); "but the rest are of some as yet undetermined category, perhaps Deg" (Jack. 1977:165).

8. It is also claimed that this theory prevails over that of Bresnan's (1973), in which the main assumption is that adjectives (+adverbs) can be preceded in surface structure by the comparative word *more* but not by *much*. To account for this rather idiosyncratic fact, a general rule of '*much-Deletion*' is employed. This rule is stated as:

1. $much \rightarrow \Phi / \dots -A|_{AP}$ (oblig.).

A second important rule is then employed, the '*-er-Cliticization*' stated as:

2. a. $more \leftarrow -er$ much many
less $\leftarrow -er$ little
- b. $-er Q \rightarrow Q + er$ (subsequent spelling rules yield *more...*)

The order of application of these two rules is strictly 2,1 and they are responsible in ruling out **as more*, **too more*, **that less* etc. The general structure, then, is:

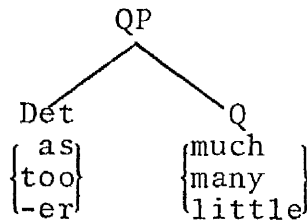

On the output of *-er-Cliticization* rule rules for simple comparatives apply to yield the suppletive form *taller* etc. We thus have the following ordered set of rules:

- a. $[-er\ much] tall$
 - b. $[\Phi\ much-er] tall$
 - c. $[much-er] tall-er$
 - d. $[\Phi] tall-er$
- rules for simple comparatives

Jackendoff's theory is claimed to express the generalization missing from Bresnan's theory, that *more* is assigned to the category Deg and that QP is absent in most APs.

9. We should bear in mind however that this type is the least common of all. It is rather marked as ?. Not surprisingly, since corresponding superlative strings (*ekpliktika poli*) are similarly rather odd if compared to *ekpliktika omorfos*.

10. In fact such bad sequences may be heard in everyday speech from time to time. If we wanted to account for them, we would let the feature [+comp] ascend from both Spec A and A itself (or SpecAdv and Adv). I consider these strings peripheral, anyway.

11. There is a tendency, though, in colloquial MG to use the comparative - as well as ordinary [+Q]-adverb(s) immediately before the noun, cf. note 1. Thus, things like

Ine pyo anthropos
is-3rd s. more man...
(he is more (of a) man...)

This is clearly an (analogical?) development of the adjectival structure, which, at best, shows the tendency of the language towards generalizations.

12. It cannot be, either, that in 41a we have two independent constituents (*tosa* in N'' and *polo* in N'), because this would be a violation of any sort of specifier constraint - the possibility of two consecutive [+Q] specifiers. Or, alternatively, it would destroy the symmetry of the distribution of the [+Q] feature under *toso(s)*.

13. Unlike *pola*, which can participate in these constructions:

Ta pola pu ekho dhen da ekhis esi
Ta pola vivlia pu ekho dhen da ekhis esi

I consider exclamatory phrases of the type

Ta osa ekho travixi !
the as many have-I suffered !
What I have suffered !

as idiomatic rather than providing positive evidence for the possibility of *osa* being normally preceded by the definite article.

14. The fact that we get things like:

I anthropi itan tosi pu...
the men were so(many) that...

i.e. predicative use of *tosos* may be further evidence for *tosos* being like *polis* (in N').

15. The fact illustrated in note 11 appears to be more general. Thus, not only comparative adverbs but also ordinary [+Q] adverbs can precede nouns. Such cases constitute a recently developed type of expressions of idiomatic usage. These expressions form a restricted set and contain the adverb *poli* (and its opposite *katholu*) (see note 1).

16. There is, however, a complication here, since the other items occupying the Deg position are always [+Q]

(*arketa* etc.). Thus, there must be some way - I do not know which - by which it will be ensured that the [$\pm Q$] under Deg refers only to *toso*. One such way could be splitting this position of A" into two: Adv" [$+Q$]-always- and Deg [$\pm Q$] for *toso*.

17. This is basically in accordance with what Rivero (1980b) claims for Spanish - namely that Quantifiers (our [$+Q$] adverbs) without degree adverbials cannot be modified by other quantifiers; on the other hand degree or quantity adverbials can be preceded by other adverbials of the same class, and this is true of Q as well: Q that contain degree or quantity adverbials can be further modified by other quantifiers. Therefore, recursion is claimed to be a property of adverbial phrases but not of Q, so the two categories must be kept distinct. Her degree or quantity adverbials are equivalent to our [$+comp$] adverbs.

18. E.g. Pyo omorfos
 [$+Q$] [$-Q$]
 Pyo polis
 [$-Q$] [$+Q$]

19. Recall that we include the indefinite article among other [$+Q$] articles in N". We can further justify this suggestion by stressing the fact that it may be not a mere coincidence that the indefinite article, the so-called indefinite pronoun and the numeral one are all expressed by the latter *-enas* (one).

20. E.g. *a number of men* but **the number of men* at least if the latter is seen without any further qualification incorporated in a RC, PP etc - in which case *the number of men* would have a consistive (noun complement) reading. Akmajian and Lehrer further show that a

similar case is exhibited by predicate nominals:

John is^a_{the} student; thus, "when NPs are dominated by QP or VP only a restricted subset of NPs actually occur;... it seems to be a more generally necessary restriction" (Akm. @ Lehr.1976:411).

21. However, there are other adjectives, apart from 'privative', that cannot be preceded by measure phrases: *omorfos, kalos, exipnos...* It appears that these adjectives can be specified only by quantificational (or degree) adverbs, for some semantic reason of which I am not aware.

22. I shall not deal with the way he accounts for pre-nominal adjectives, but I shall refer to some of his remarks, since they will be useful for the discussion of the MG adjectives.

23. For example:

| | | |
|-----------------|---|----------------------|
| X is a lawyer | } | →X is a lawyer and a |
| X is a criminal | | |

X is a criminal lawyer.

24. Sussex explores some of the factors that determine the surface order of adjectives in the case of stacking (e.g. the genuine old wooden chair, the genuine wooden old chair etc.). His conclusion - that attributive adjective order can possibly be best handled by a semantic - based grammar - does not concern us here, since we shall not deal with the problem of ordering of a number of adjectives. Nevertheless, some of his remarks are helpful and suggestive as far as the 'history' of the treatment of the derivation of (prenominal) adjectives is concerned.

25. Not without residual problems, however; cf. Sussex 1974: "The Lexicalist Hypothesis is a partial improvement over this position, but only in that it does allow some adjectives to be derived. It still cannot explain the restrictive/non-restrictive ambiguity in derived adjectives, with serious implications for the paraphrastic notion of transformations.... Furthermore, it is difficult to see how the line between derived and nonderived adjectives can be drawn in a non *ad hoc* manner" (pp.127-128).

26. Jackendoff argues against the determiner analysis of restrictive modifiers by showing that these satisfy the use of the definite article, but their attachment to determiner, apart from adding 'an otherwise unmotivated option in the base rule of the determiner', requires also an additional extraposition rule in the case of PPs and RCs. On the other hand, the NP-complement theory, although it establishes a discontinuous fashion for these categories, needs a single interpretive rule for all restrictive modifiers. Bach (1974) also argues against the determiner theory of RCs but on the favour of the NP-S (i.e. the 'Chomsky-adjoined') analysis; one of his arguments concerns adjectival and other modifiers and their correct order with respect to their head nouns, given the rule of Adjective-Shift (cf. "under the Det-S analysis we must either first postpose the clause, reduce and then reposition the right set of modifiers before the noun, or state a much more complicated condition for postposing the right set of postnominal modifiers...." (pp. 272-73).

27. Cf. "Proper nouns can also be used as Common Nouns in restricted ways, e.g. 'this cannot be the England that I know'(Chomsky 1965:217) .

28. We will claim that restrictive relatives are complements of N'. The fact that even rarely they can precede the noun - i.e. appear between the (usually indefinite) article and the noun - can be explained by what is stressed by Bolinger with regard to the 'characterizing' property of the attributive slot.

29. We, thus, see that what constitutes an ungrammatical string for English (cf. Bach 1974:272) is OK in MG.

30. The fact that PPs and genitive NPs that can occupy the prenominal position generally have an adjectival (morphologically identical) equivalent, constitutes the object of a separate - and interesting - study. Presumably this is due to the fact that adjective is the category 'par excellence', which occupies the prenominal position; cf. *Khoris pira - apiros, apo soi - soilidhikos* (from a good family), *me besa - besalidhikos* (honest) etc.

31. I recently read in a newspaper '*Yineka bukadhorisa pyastike sta prasa*' (a woman burglar was caught in the act). The modifier *bukadhorisa* is clearly a complement, notice that *bukadhorisa yineka* is very odd - if not unacceptable - unless it is thought as appropriate or suitable to characterize women as burglars (cf. Bolinger 1967:7).

32. Cf. "The position of attributive modification is often occupied by common nouns, locative adverbs, simple PPs" (Tzartanos 1946:69).

33. Further evidence for this relationship is provided by the fact that adjectives that cannot occur as post-nominal complements (cf. examples 37-41) lack of a paraphrase in which they appear as predicates of a copulative

RC as well, cf. *mnya kritiki pu ine theatriki.

34. Of course, these complements, as when they are in prenominal position, can be conjoined - in any order. I assume that their conjoinability in that (postnominal) position is accounted for by their common feature complexes as well.

35. The only item that precedes the definite adjective is the demonstrative *aftos/ekinos* (*this/that*):

o kirios aftos o kalos
*o kirios o kalos aftos (without comma before the
demonstrative)

Thus, we must have:

$H' < Dem < \alpha < \dots$

36. In fact, 76b is ambiguous: the two complements may be modifiers of the same noun, or a second head may be understood after *ke*. I.e. *ke* may conjoin either two complements of the same NP or two NPs. As we shall see, this may be due to the NP status of the 'definite' adjectival string.

37. Notice that the following cases of conjunction are possible too:

- o mathitis o ikanos ke oso dhen fandazese sinepis
the student the efficient and as(much) not imagine-
2nd s. consistent
- o mathitis o ikanos ke o oso dhen fandazese sinepis

In the first example the conjunction of *o ikanos* with an adjectival free relative shows that this, too, is an adjective. In the second example, the addition of the definite article

in front of the adjectival relative makes it a nominal relative (cf. note 36 and 38).

38. It may be helpful to note that from a diachronic point of view a free relative is also equivalent to an adjectival participle preceded by the definite article, e.g. *o ekhon* (the one who has...). This participle can be conjoined to an NP, in contrast with an adjectival (relative) participle:

o mathitis o ikanos ke { *o ekhon...* }
 { **ekhon...* }

This further supports the nominal status of Free Relatives.

39. This seems to be a property of definite NPs. Nevertheless there are examples like:

Terastio ena stafili... !
huge a grape
A huge grape

Yemato ena pyato efaye !
full one plate ate-3rd s.
He ate a full plate of food

These occur only as exclamatory expressions but they may also support the assumption that what is described here is a general property of N' adjectival complements, not only of definite NPs.

40. Incidentally, the ungrammaticality of the *poet who is Burns* is just one more argument against the relative clause reduction analysis.

41. The argument with regard to [det] is that *the* in

The poet Burns

belongs to the proper name, because at no stage of the derivation can *The poet* be a constituent, for *poet* is not specified. Moreover, it is a fact that any proper noun when modified requires a determiner.

Consequently, it is claimed, NP nodes dominating a name should also dominate a determiner node; if the name has not a modification attached to it, the determiner node will remain unfilled.

We can recall here that proper names are always preceded by the definite article in MG.

42. Burton points out that complements of copulae do not have a referent but only a descriptive or classificatory role. And by her derivation *poet*, *friend*, *point* are underlyingly complements of the verb *to be*.

43. If it is assumed that *the poet*, *my friend*, *the point* are complements - as we saw and we shall further justify with regard to MG - this contrastiveness is explained.

44. It is strange that only non-restrictive apposition is mentioned and described in the *College Syntax* of Dhimotiki (1976). The only hint for another sort of apposition is this: "there is no need for comma when the appositive modification is so tightly bound to the noun as to constitute a single unit with it" (p. 57, translation mine).

45. Noun here can also be common or proper (e.g. *o Pinios potamos*) but for simplicity we ignore this now.

46. Notice that when such nouns are attributes, the modified noun is semantically 'empty' - *anthropos*, *pedhi*, *yineka*. It seems that it is the modifier that carries the semantic 'burden' (cf. p. 133).

47. All these remarks concern gender agreement between the modifier and the head noun. Number and case agreement is inviolable and clear in every case (since nouns have number and case, but their gender distinction is different from that of adjectives. They require adjectival concord, they do not obey to it (Lyons 1968), hence the cases where certain nouns cannot - of necessity - follow the gender of the modified noun).

48. We can mention here that the constituents of Table 2 are both (head and complement) 'self-contained' (Burton's term denoting that each of the constituents has its own article), whereas the constituents of Table 1 are not. More accurately, in Table 1 the article belongs exclusively to the head noun, the modifying category lacks a determiner. This can be further supported by the following:

- a) It is counter-intuitive for the modifier to be definite (in definite NPs) since it is unspecified.
- b) If the article belonged to the modifier in the case of *o piitis Solomos*, the proper name would be left without article, which in MG is impossible, because proper names - unlike common nouns - are always preceded by the definite article.
- c) If the definite article belonged to the modifier, the latter could well be indefinite. But if we compare the

*Enas piitis Solomos

with Enas kalitekhnis fotografos

we see that the former is ungrammatical again because

names in Greek can only be definite, whereas the latter is OK, because nouns can be preceded by either article. Burton, too, uses a similar argumentation to show that in *The poet Burns the* belongs to Burns and not its modifier *poet*, therefore this string exhibits attributive modification and is not a case of apposition. It is interesting that Burton's discussion through a different process coincides with Jackendoff's claim that a certain class of restrictive modifiers requires the use of the definite article with proper names (cf. p.119) and that *The old John* is quite different from *old John*. Correspondingly, *o piitis Solomos* is attributive modification, but *o piitis o Solomos* (parallel to *old John*) is a case of 'apposition' (though not parallel to appositive relatives as implied by Jackendoff).

49. Strings like 3 and 8 of Table 2 are assumed to belong to the same phenomenon, although we shall not deal with these. They exhibit at least two properties, one of which coincides with those of other strings of Table 2. First, both head and complement are obligatorily definite. Although demonstratives (as well as personal pronouns like *egho* etc.) are not explicitly definite, definiteness must be considered as their inherent characteristic. Consequently the feature [+dem] for *aftos* etc. must be seen as an abbreviation for [+dem+def]. This is sufficient to explain why *aftos* although occurring only in definite NPs is not preceded by the definite article. Second, demonstratives can precede the whole NP, like definite adjectives. Because of the inherent definiteness of demonstratives we do not get things like:

*o aftos o anthropos

much as we do not get

*o o kalosoanthropos

The distributional similarity between *aftos* and definite adjectives - given the definiteness of *aftos* - also accounts for the following symmetry:

a. $\left\{ \begin{array}{l} *o \text{ aftos } o \text{ anthropos} \\ o \text{ kalos } o \text{ anthropos} \end{array} \right\}$ b. $\left\{ \begin{array}{l} *o \text{ anthropos } o \text{ aftos} \\ o \text{ anthropos } o \text{ kalos} \end{array} \right\}$

a' : $\left\{ \begin{array}{l} \text{aftos} \\ o \text{ kalos} \end{array} \right\} o \text{ anthropos}$ b' : $\left\{ o \text{ anthropos} \begin{array}{l} \text{aftos} \\ o \text{ kalos} \end{array} \right\}$.

III. SOME NP COMPLEMENTS

0. Introduction (Some general remarks on the position of NP Complements)

In this chapter we shall present three types of complements of NPs: the so-called 'consistive' complement, the partitive complement, and a complement labelled by the feature [+nominative] for the reason that will become clear in C 1. But before these particular types of complements are discussed, I think it is necessary to present the basic argumentation according to which complements in general are positioned within X^n in Jackendoff's theory, which I will assume throughout this chapter.

The term complement is an abbreviation for anything that strictly follows the lexical head of a phrase. As Jackendoff points out Comp(lement) is a term referring to some sequence of nodes and is never referred to as a constituent; therefore it does not stand for a node. The general rule schema showing material on the right of the head is

$$X' \rightarrow X\text{-Comp},$$

where X stands for the major categories V,N,A,P (Jack. 1977:14). According to the Uniform Three Level Hypothesis there are three complement positions in a phrase. Jackendoff argues that there are principled distinctions among the three levels of complements, which can be classified on semantic grounds as functional arguments, restrictive modifiers, non-restrictive (appositive) modifiers. Accordingly, the X' position is identified with functional arguments, the X'' with restrictive modifiers, and the X''' with non-restrictive modifiers. Functional arguments are those lexical items which "strictly subcategorize phrases in their environment" (Jack. 1977:57);

for example, the noun "*part(of)*" strictly subcategorizes an NP, and can be treated semantically as a function $g(x)$ which maps terms into terms" (ibid). Functional arguments come immediately after the head, preceding all other modifiers, and "many grammarians have had the intuition that they are the most "tightly bound" to the head of all the complements. This intuition can be expressed by assigning all and only the strictly subcategorized phrases to the X' Complement in deep structure" (ibid p.58). Now, the formal 'diagnostic' criteria for X' complements are: first the fact that the functional argument cannot be omitted without incurring ungrammaticality; second certain anaphoric processes — for NPs in particular the use of the pro-N' *one*. There is a contrast in the applicability of *one* depending on whether the complement is in N' or in N'', cf.:

1. *The King of England and the one of France

1.a The King from England and the one from France

The two PPs in this pair of examples play different semantic roles. *Of England* specifies part of the function of being *king*, therefore it is a functional argument; *from England* is a restrictive modifier - i.e. in N'' - since it "specifies a somewhat inessential part of kingship" (Jack. 1977:58). This differentiation is further justified by the order of these complements: only one order is possible, that according to which the N'' complement follows the N' one, cf.:

2. *The King from France of England

2.a The King of England from France

Thus, the pro-N' one test distinguishes N' from N'' complements; the pronoun *one* cannot be followed by the phrase *of NP* within the N' complement. By the same test it is shown that *of wine* in *Bill has two quarts of wine* (i.e. in the consistive complement, see below A3) is a complement of N': (cf. **the quarts of wine and the ones of water were left behind*). Another test to distinguish N' from N'' complements is based on evidence provided by the scope of quantifiers; a quantifier "may extend its scope out of an NP dominating it if it is in the N' Complement but not if it is in the N'' complement" (Jack. 1977:60). E.g.:

3. Fathers of few children have any fun
- 3.a* Fathers with few children have any fun

Of few children by the pro-N' one test is proved to be an N' Complement, whereas *with few children*, since it can be paraphrased by the relative clause *who have few children*, is an N'' Complement. This is further reinforced by the order of the two PPs:

4. Fathers of few sons with many daughters

However, "there are certain cases that appear to be ambiguous between N' and N'' complements without appreciable difference in meaning. (...) The simplest solution is to accept both sources for such a case" (Jack. 1977:60). Such is the case with:

5. Bill's picture of Fred

Of Fred can be considered as either an N' or an N'' Complement.

The distinction between N'' and N''' complements is

more straightforward and amounts to the fact that restrictive modifiers (the term *restrictive* is due to the fact that they restrict the extension of X'') may be focused, clefted and affected by sentence negation, in contrast to nonrestrictive (X''') modifiers. This difference is borne out most clearly in the restrictive v. appositive relative clause distinction (see p.267). Restrictive relatives follow N' complements without a break, may contain foci and may be affected by sentence negation; appositive relatives are separated by comma intonation, may not contain foci and may not be affected by sentence negation. But apart from restrictive relatives, the N'' Complement position includes also PPs of time, place (cf. the King *from England*), accompaniment, and descriptive adjectives, which "despite their prenominal position have similar semantic properties to these PPs, arguing that they are attached to N'' This of course makes them parallel in structure and function to preverbal VP adverbs, which are in V'', consistent with the predictions of the X'-Convention" (Jack. 1977:63).

Our grammar predicts three levels of complements, too; but these positions do not correspond exactly to those of Jackendoff's Syntax. The following tree will show clearly the difference between the two grammars:

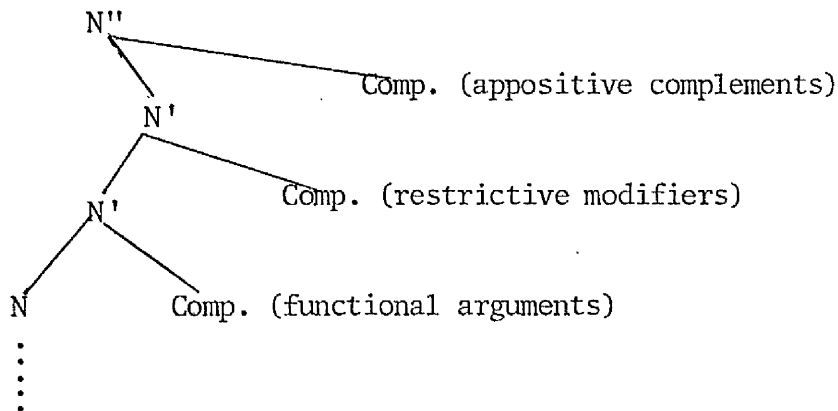

In Chapter II we claimed that N' is recursive, so that provides us with an 'extra' level; thus, even in our two-bar system, we can get the positions needed for the placement of complements, given, on independent grounds, that N' is a recursive node. Complements of N are functional arguments - i.e. strictly subcategorized items, such as the partitive, the consistive and the [+nom] complement, as we shall see in this chapter. Complements of N' are restrictive modifiers, such as restrictive relatives; we also saw that a semantic parallelism between APs and RRCs on the one hand, and between PPs and RRCs on the other, forces us to consider APs and certain PPs as restrictive modifiers, too - a syntactic parallelism between these categories is thus established - consequently as complements of N'. Cf. "In N" the complements include PPs.... and (for semantic reasons, their prehead position notwithstanding) APs" (Jack. 1977:72-73) (see II.3.2). Appositive relatives is the most representative complement under N" - we shall see in chapter IV that there is good evidence for attaching appositives under N".

It is further worth stressing that all the syntactic categories may occur as complements of an NP (i.e. V" [\pm R], P", N", A"(djective-dverb). But are there any formal criteria for distinguishing functional arguments (i.e. complements of N) from restrictive modifiers (i.e. complements of N')? As far as I can see there are two tests that can be used to this effect: the pronominalization process corresponding to pro-N' one in English, and the order of complements according to the level in which they appear (Jackendoff's 'geometry' of the complement system). The former involves the definite pronoun *aftos* or *ekinos* in definite NPs, and the indefinite *enas* or *kapyos* in indefinite NPs. These anaphoric items replace the head

noun leaving behind its complement - we claim the complement of N' only (a restrictive modifier). Along these lines consider:

6. O andras me ta yalya Ky ekinos me to kapelo
The man with the glasses and the one with the hat
7. O mathitis o kalos ky ekinos o aneprokopos
The good student and the one who is awkward
8. O kirios pu milise ky ekinos pu dhen anixe to
stoma tu
The man who spoke and the one who did not open
his mouth

The complement of the above examples must be considered as a complement of N' - i.e. a restrictive modifier - given the applicability of *ekinos* 'pronominalization'. The same test does not apply in examples where a [+nom] complement of N (see C) is involved. The following two examples show that the genitive which is called 'objective' is indeed a complement of N (i.e. a functional argument), according to the pronominalization test applied here:

9. *I ekmetaleftes tu anthropu ky ekini tis
ergasias|
the exploiters (of)-the people and {the ones|
(of)-the work.} those
- 10.*?O singhrafeas tis Odhisias ky ekinos tis
Theogonias.|
the author (of)-the Odyssey and that (of)-
the Theogonia.|

The above two examples provide more support for the notion

of 'object' as generalized over sentences and noun phrases (see Chomsky 1970, Jackendoff 1977). The same holds true of the so-called subjective genitive. Subjects too are functional arguments - i.e. strictly subcategorized items - only that they usually precede the head (Jack. 1977:57-58); (but cf Horrocks (1983) who claims that in flat sentences subjects behave distributionally just like (subcategorized) objects (p. 100)). However, other genitival complements belong to N', according always to the *ekinos* 'pronominalization' test:

11. O proedhros tis Ghalias ky ekinos tis Italias
the president of France and _{{that} the one of Italy.

Thus, possessive genitives are probably complements of N', functioning as restrictive modifiers (these, too, "satisfy the constraint on use of the definite article" (Jack. 1977: 177)).

Now, in one level there is often more than one complement (even two complements of the same category, as, e.g. two PPs). Within the same level the order of constituents is accounted for by LP rules (see p. 15). We have already seen (II.3) that adjectival and prepositional complements of N' are interchangeable, and that restrictive relatives always come last. Consequently it is the following rule that accounts for the order of complements of N':

$$H' < \alpha < V[+R]'' ,$$

where α is a variable over AP, PP and possessive genitive NPs. A similar rule accounts for the order of complements of N:

$$H < \alpha < V'' [+C]$$

Here V'' [+C] stands for subcategorized subordinate clauses introduced by *oti*, *na*, *pos* etc.; e.g. *i iposkhesi oti tha erthi* ('the promise that will come'), *i dhiiyisi pos sinandithikan* ('the story of how they met').

The above rules are really rule schemata - a conflation of several rules, as for example $H < N'' < V''$, $H < P'' < V''$ etc. As already hinted at above, the order of constituents represented by α is free, and α in the second of the above rules is a variable over N'' and P'' (and N'' in that position may be [+genitive], [α case] or [+nominative]). In the coming pages, we shall consider in detail [α case] ('appositional'-parathesis), partitive and [+nom] complements.

A. A CONSTRUCTION WITH A DOUBLE MEANING: THE SO-CALLED PSEUDOPARTITIVE AND NOUN COMPLEMENT (CONSISTIVE) STRUCTURES.

0. Introduction

In this section we shall be concerned with noun phrases of the sort:

1. Ena buketo luludhya
a/one bunch flowers
A bunch of flowers
2. Ena pyato fai
a/one plate food
A plate of food
3. Ena plithos aperyi
a/one crowd strikers
A crowd of strikers

which are grouped together as a special type of 'parathesis' ('apposition') by Tzartanos (1946:65-67), and which are ambiguous between a reading like 'a bunch consisting of flowers' and a reading like 'flowers of a quantity equal to a bunch'. The first reading is called 'consistive', the second 'pseudopartitive'. We shall offer evidence for the structural ambiguity of strings like 1-3, and two different structures will accordingly be proposed by means of which 'double' verb agreement and selectional restrictions will be explained (cf. examples 26-30 below).

1. The Pseudopartitive construction in English

But before discussing the MG facts in detail, I begin with a survey of pseudopartitives in English. The term 'Pseudopartitive' was first introduced by E. Selkirk (1977) for noun phrases like:

4. A group of men
5. A cup of sugar
6. A dozen eggs

which consist of a measure phrase (for the definition of measure phrase see p. 93 onwards) and a noun, the whole being a simple NP, and not a complex one, as partitives are. We have already considered such examples, in which the measure phrase functions as an N" quantifier (in Jackendoff's grammar). We repeat here the tree representing the structure of noun phrases like 4-6 for convenience (always in Jackendoff's notation).

7.

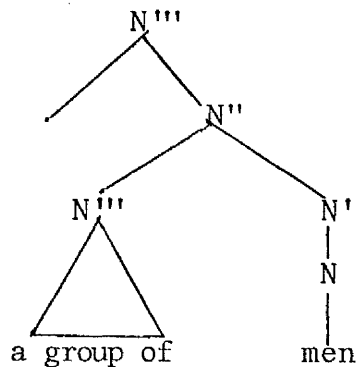

1.1 Properties of the Pseudopartitive construction

The characteristic of this structure is that the measure phrase is a left sister to N' - i.e. a specifier - and that the whole is a *single* NP. The *of* is considered as a specified grammatical formative transformationally inserted in the environment N'''-N'. As for the determiner of the highest NP (N'''), it can be either null and indefinite, or developed optionally under certain restrictions. Thus, "the evidence seems to indicate that an NP containing a group noun in its N'' specifier cannot have an Art''' in its N''' specifier.... but it is possible to have a genitive in the matrix N''' specifier" (Jack. 1977:124-125). Therefore "when a group noun in a pseudopartitive is preceded by an Art''', it is always the Art'' of the group noun, not that of the matrix N''' (ibid. p. 123).

1.2 The Pseudopartitive as an ambiguous construction

But what is of particular interest in examples 4-6, is the ambiguity pointed out by E. Selkirk (1977). This ambiguity, which makes reference to the syntactic notion "head" of the noun phrase, lies in the two readings mentioned on p. 188. So, if the NPs 4-6 are read as pseudopartitives they have structure 7, in which the measure phrase shares the same position as the quantifiers

many, few etc. If they are read as 'consistives', then the 'measure phrase' is the head of the construction and what was the head in the pseudopartitive reading is now a complement. The 'noun complement' structure of strings 4-6 is as follows:

8.

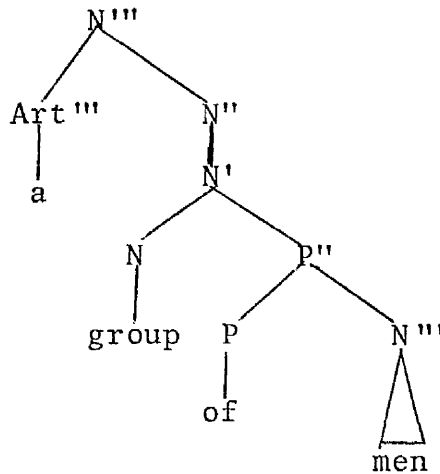

In this structure *of* is an ordinary preposition which introduces a PP. Thus, the complement here is a PP and denotes the 'material' which the head noun *consists of*.

The structural ambiguity of examples 4-6 is manifested, as Selkirk points out, through processes involving head sensitive phenomena, such as

a. Verb Agreement:

An assortment of responses to those questions
 {were} considered
 {was}

b. That group of crazies really got {itself
 {themse
 That group of crazies really got {itself
 {themselves}
 in hot water, didn't {it }?
 {they}

c. Selectional restrictions

A cup of sugar {was strewn } on the floor
 {smashed

Obviously, either of the two nouns of examples 4-6 can function as the head of the whole NP. The double structure of such strings explains the fact that an NP cannot allow both interpretations at the same time: the noun that determines selectional restrictions in the main clause must also determine selectional restrictions in a relative clause: ...

9. The cup of sugar that this recipe requires
 *crashed to
 { was strewn on } the floor

Ahmajian and Lehrer (1976) present an additional - though less trustworthy-piece of evidence for the structural ambiguity of phrases 4-6. It concerns the application of the rule of Extraposition from NP, given its status as an upward-bounded rule obeying subadjacency⁶ and the fact that NP is a bounding node. Compare the following pairs of sentences:

- 10.a. A review of (certain) answers to your
 argument was given
 b. A review was given of (certain) answers
 to your argument
- 11.a. A number of answers to your argument were
 given
 b*: A number were given of answers to your
 argument

In 10(a-b) *review* is the head and the two PPs its complements, the second subordinated to the first. The extraposition of these complements is permissible, since

subjacency is not violated. In 11(a-b) *answers* is the head, a *number* is a measure phrase and as such its left sister. Extraposition cannot apply here, even though it is exactly the 'same' material that is being moved as in 10b. In 11b *of answers* is not a constituent, therefore it cannot move at all. Consequently, pseudopartitive noun phrases do not have the same behaviour with respect to the rule Extraposition from NP as do noun phrases whose *of*-phrase is a complement of the head noun. Notice that this remark combines nicely with verb agreement indicating independently the structural ambiguity. Furthermore, extraposition, which is blocked in 10a by subjacency, giving the ungrammatical 10c:

10c. *A review of (certain) answers was given to
your argument

is possible in 11c.

11c. A number of answers were given to your arguments,

since *answers* is the head, and not a complement; the complement *to your argument* can be extraposed, because it belongs to the same 'cycle' and subjacency is not violated.

1.3 Summary

To summarize so far, noun phrases like those in 4-6 are structurally ambiguous. They can be read either as pseudopartitives, in which case the measure phrase (the 'NP-like quantifier' as measure phrases are described by Akmajian-Lehrer (1976)) is a specifier of the head - the second NP - and specifies a certain amount of what

is denoted by the head, or they can get a consistive reading, in which case the measure (or unit) phrase is the head and the second NP is a complement - according to Jackendoff (1977) and Selkirk (1977) an N' Complement.

2. A type of ambiguous appositive complement in MG

In II.2.3.2 we discussed measure phrases in NPs in MG, and evidence for considering them as specifiers of nouns was presented. In particular, we assumed that measure phrases, being in fact 'NP-like quantifiers', have the same syntactic and semantic function as quantificational articles. We also explained why it seems preferable to attach these specifier elements in N'' and not in N' (corresponding to Jackendoff's N'' position). The basic advantage of this attachment is that the inherent indefiniteness of measure phrases in such strings is naturally accounted for, and there is no need for additional restrictions in the expansion of measure phrases as if they were in N' (Jackendoff's N'') specifier position (cf. p. 189).

Finally, we saw that assigning the feature [+Q] to measure phrases allows for the Specifier Constraint to operate to block bad strings in which a [+Q] adjective follows a measure phrase.

All these remarks relate to measure phrases when they participate in the *pseudopartitive* construction, i.e. when they are read as indicating an amount of what is denoted by the head noun. In this chapter we shall contrast the pseudopartitive reading of the noun phrase in sentences 57-59 (p. 94, ch. II) to the consistive reading of the same NPs. Evidence for this distinction will be offered and a structure for the consistive reading will be proposed. But before the structural ambiguity of the NPs in sentences 57-59 is discussed, it is worth

discussing in some more detail certain properties of the pseudopartitive construction we did not discuss in the section on measure phrases.

2.1 Some more notes on the 'pseudopartitive' construction

Given the following two structures for 'pseudopartitives'

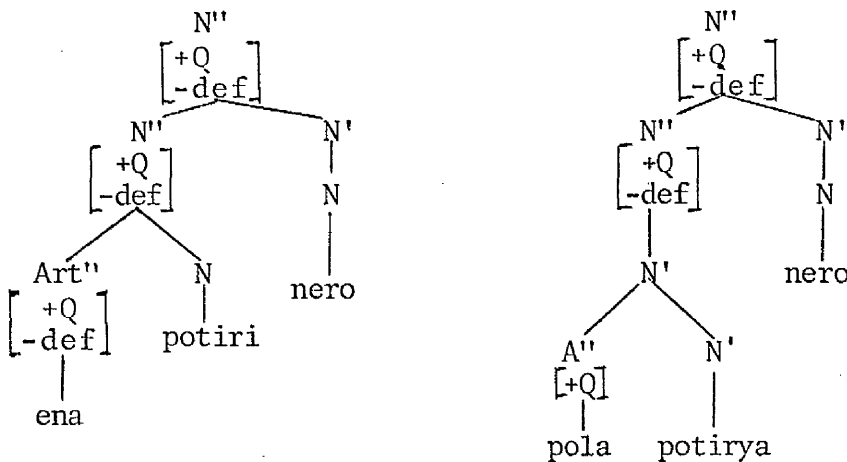

and what was said in 2.3.2.1 about the features [-def] and [+Q] of the highest N'' and its N'' specifier, the following question concerning the assumed feature [+Q] of the specifier N'' may be asked - how is the class of [+Q] N'' determined? It seems odd to consider *potiri* in *ena potiri nero*, or *kuti* in *ena kuti spirta* as inherently [+Q]. We said earlier that what is important here is the fact that a measure phrase by definition contains a *quantified* noun. Accordingly, the feature [+Q] under N'' of the measure phrase must be considered as a foot feature, ascending from its specifiers - cf. the tree structures above (both specifiers, N'' and N', are [+Q]), and also II 2.3.2.1 -, only nouns that are inherently quantificational can occur as measure phrases without a [+Q] specifier (e.g. *plithos*), for the feature [+Q] may descend

directly onto the head, without any specifier preceding the head (cf. *plithos luludhya/a great number of flowers*). We, then, make the stipulation that [+Q] is a feature assigned by the N" rule - the *only* N" specifier of N' is necessarily [+Q]. Of course, this would still give us semantically anomalous strings like

12. *Ena trapezi mathites
a/one table students

13.* Ena zminos nero
a/one swarm water (cf. 66b on p. 101)

Instead of resorting to some sort of semantic filtering in these cases, we can, alternatively, consider the nouns of measure phrases as *classifiers*.

2.1.1 Measure or unit nouns as 'classifiers'

Classifiers constitute a system of "noun-classification for the purpose of enumeration and individuation found in many languages of south-east Asia" (Lyons 1968: 288). Some classifiers may be regarded as semantically empty, whereas others are specific to certain classes of nouns and they can be used as nouns in other contexts. To understand the notion of classifier, we can cite a corresponding example in English. Let us suppose that the nouns *tree* and *fruit* are used as classifiers in

Three tree banana (Three banana trees)
Three fruit banana (Three bananas)

The difference between *Three bananas* and *Three banana trees* lies exclusively in the particular classifier involved (*tree-fruit*).

K. Allan (1977), in an extensive article called 'Classifiers', discusses the properties of classifiers in classifier languages. We can pick out some of his observations and claims, which will be useful in seeing in what sense exactly measure phrases in our examples can be viewed as some sort of classifiers. Along these lines, the typical function of classifiers is to index some perceived characteristics of the phenomenon to which the classification refers. They reflect perceptual groupings, and reclassification may be used in order to indicate the speaker's evaluation of what he perceives as unusual.. In other words, classifiers are linguistic correlates to perception, and when the perception of a given object changes, the classifier in turn may change. This happens because classifiers denote some salient perceived or imputed characteristic of the entity to which an associated noun refers (the one which they classify). This is the basic characteristic of classifiers and is claimed by the author of the above article to constitute the strongest evidence of semantic classification. It is related to the ability of native speakers to classify new objects consistently and easily on the basis of their observed characteristics. In the simplest case a noun is classified on the basis of some characteristics shared by its referents. Such a characteristic may be culture free or culture bound. Along these lines it seems as if *any/ every* object of our world can be measured or classified by an appropriate classifier (measure phrase). Cf.:

14. Ena fortigho rodhakina
a/one lorry peaches
A lorry of peaches

15. Dhyo rizes elyes
two roots olive trees
two olive trees
16. Ena fortoma stari
a/one load wheat
A load of wheat
17. Dhyo tsighara dhromos
two cigarettes way
A distance (route) of two cigarettes
(i.e. which takes the smoking of two
cigarettes to cover)
18. Dhyo bukalya { bira
two bottles { beer
 { krasi
 { wine
 { lemonadha
 { lemonade }
19. Mnya klosti metaxi
a/one thread silk
A thread of silk etc.

It is clear that each noun in the above examples requires its own classifier (or classifiers¹, since a class of objects may happen to have characteristics captured by more than one classifier). Thus, liquids in general are usually put, transported and used in *bottles* (*bukalya*), *glasses* (*potirya*), or *cups* (*flitzanya*), food is used in *plates* (*pyata*), cigarettes, matches etc. in *boxes* (*kutya*). ←
It is very unlikely/odd/impossible for beer to be put in a box:

20. *Ena kuti bira
a/one box beer
A box of beer ,

property.

But the parallelism of classifiers and what we are considering as measure phrases goes even further. Allan distinguishes seven categories of classification (a) material, (b) shape, (c) consistency, (d) size, (e) location, (f) arrangement, (g) quanta. These seven categories² range over all the predictable bases for noun classification except colour. The last two occur in languages like English which are not classifier languages. The first five exist only in classifier languages. It is claimed of the last two types that they do not classify entities according to their inherent characteristics, and this is why they are not confined to classifier languages. Examples of 'arrangement' classification in English are *two loops of rope* ~ *Two coils of rope*. (Allan claims that *loop* and *coil* being nouns in English are the heads of the constructions in which they appear (but cf. below). In principle, English has an unbounded number of arrangement classifiers, and verbs are a productive source for this subcategory of arrangement classifiers (*pleat, fold, twist, coil, loop* etc.). It is further shown that the arrangement category intersects with the quanta category in a subsidiary capacity in those classifiers which identify objects in some kind of specific non-inherent distribution (e.g. *heap, clump, bunch, herd*). This is interesting, for we see that this relation between arrangement and quanta classifiers (in English *cup of tea, grain of sugar*, where *cup, grain* etc. are called by Allan unit counters and claimed to be used only with collective, uncountable (e.g. *wheat, wine*), pseudouncountable and pluralia tantum nouns; it is only the unit counters that show grammatical gender) is borne out syntactically as the ambiguity of such strings between a pseudopartitive and consistive reading - the pseudopartitive related most probably to

quanta classifiers and the consistive to arrangement classifiers -. Now, it is worth stressing that the Greek examples cited above correspond exactly to the English examples claimed to involve arrangement and quanta classifiers, as the translation given shows - apart from a slight difference, the appearance of *of* in the English phrase (but cf. the optionality of *of* in such strings, at least in American-English, see Selkirk 1977).

What is in order now is to consider the consistive reading - corresponding to the 'noun complement' structure - of strings like:

- 23. Ena buketo luludhya
a/one bunch flowers
A bunch of flowers
- 24. Ena plithos aperyi
a/one crowd strikers
A crowd of strikers
- 25. Ena kuti biskota
a/one box biscuits
A box of biscuits

2.2 Evidence for a second structure

Evidence for a second structure of 23-25 is provided, as in the case of similar English strings, by phenomena that relate to the head of the whole NP - namely verb agreement, selectional restrictions, and, secondarily, cliticization - . Let us consider the following sentences:

- 26.a. Ena bukali ladhi khithike
a/one bottle oil was spilt
A bottle of oil was spilt

the object of the sentence reappears as the clitic pronoun, shows the existence of two heads in the object NP. It is 26b, 27b, 28, 29 and 30, when the head is the first noun of the subject/object NP, that represent the 'consistive' reading. But what is meant by 'consistive' reading? What is the structure underlying it?

3. The so-called 'consistive complement'

The consistive complement is expressed by one of the following types of complement: an *apo* ('of') prepositional phrase, a genitival NP, and, as we see now, an NP which agrees in case with its head, i.e. which is declined along with its head, hence called [α case] complement. It is precisely because of this feature that [α case] complements are considered as 'apposition' ('parathesis' - i.e. *juxtaposition* of two nouns agreeing in case). Consistive complements are illustrated below:

- 31.a. Ena plithos apo anthropus
a/one crowd of people
- b. Zminos apo khelidhonya
swarm of swallows
- 32.a. Plithos anthropon
crowd people (gen.)
- b. Kataloghos onomaton
list names (gen.)
A list of names
- 33. Ena buketo luludhya
a/one bunch (consisting of) flowers.

Given the close relationship between head and complement

in examples 31-33, and the fact that the complement is strictly subcategorized by the head noun, the consistive complement must be seen as a functional argument of the head N. The following structure accounts for consistive complements:

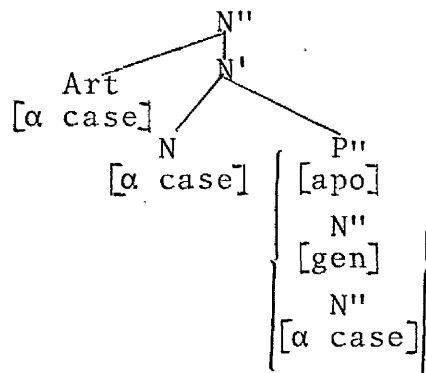

The NP *ena buketo luludhya* is structured as follows:

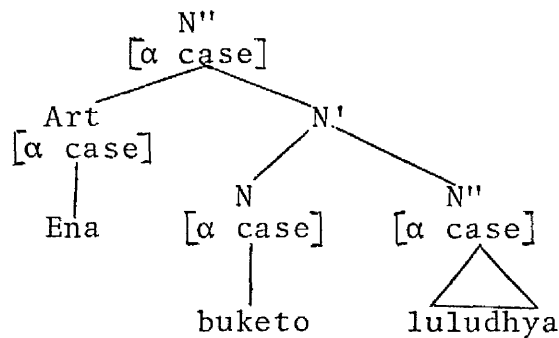

There is an interesting fact concerning all types of consistive complements, but [α case] ones especially. Thus, if the head noun is definite, i.e. if Art is occupied by the definite article, the complement must also be definite (unless the complement noun is used generically). Cf.:

- 31.a' ??To plithos apo anthropus
- b' ?To plithos apo tus anthropus³

- 32.a' ??To plithos anthropon
b' To plithos ton anthropon
- 33.a' *To buketo luludhya
b' To buketo ta luludhya⁴

Consider in addition to the above:

- 34.a. Mnya parea turistes
a group tourists
b. *I parea turistes
c. I parea i turistes
the group the tourists
The group of tourists
- 35.a. Ena pyato fai
one plate food
b. *To pyato fai
c. To pyato to fai
the plate the food
The plate of food

3.1 A note on lexical subcategorization concerning
consistive complements

What must be stressed with regard to the three types of consistive complements is that they will be introduced by three separate (lexical) rules because the exact type of complement, as strictly subcategorized by the head noun, depends on its inherent properties. For example, collective and group nouns (such as *group*, *company*, *crowd* etc.) can introduce all three types of complements, e.g.

36. $\left\{ \begin{array}{l} \text{Ena grup} \\ \text{plithos} \end{array} \right\} \left\{ \begin{array}{l} \text{anthropi} \\ \text{anthropon} \\ \text{apo anthropus} \end{array} \right\}$
- one $\left\{ \begin{array}{l} \text{group} \\ \text{crowd} \end{array} \right\} \left\{ \begin{array}{l} \text{people} \\ \text{people (gen.)} \\ \text{of people} \end{array} \right\}$

Measure or unit nouns, though, can only introduce $[\alpha \text{ case}]$ (appositional) complements, not genitives or PPs. This differentiation can be accomplished if the relevant rules are numbered:

$$1 \left\langle \left[\begin{array}{l} N' \\ \alpha \text{ case} \\ \beta \text{ def} \end{array} \right] \left[\begin{array}{l} N \\ \alpha \text{ case} \\ \beta \text{ def} \end{array} \right] \left[\begin{array}{l} N'' \\ \alpha \text{ case} \\ \beta \text{ def} \end{array} \right] \right\rangle$$

$$2 \left\langle \left[\begin{array}{l} N' \\ \alpha \text{ case} \\ \beta \text{ def} \end{array} \right] \left[\begin{array}{l} N \\ \alpha \text{ case} \\ \beta \text{ def} \end{array} \right] \left[\begin{array}{l} N'' \\ \text{gen} \\ \beta \text{ def} \end{array} \right] \right\rangle$$

$$3 \left\langle \left[\begin{array}{l} N' \\ \alpha \text{ case} \\ \beta \text{ def} \end{array} \right] \left[\begin{array}{l} N \\ \alpha \text{ case} \\ \beta \text{ def} \end{array} \right] \left[\begin{array}{l} P'' \\ \text{apo} \\ \beta \text{ def} \end{array} \right] \right\rangle$$

Then it is stipulated that lexical items like *grup*, *plithos* etc. have the number indices 1-2-3, i.e. they belong to noun subcategory 1-2-3, so they can occur in the context admitted by all the above rules. On the other hand, items like *kilo* (*kilo*) or *buketo* (*bunch*) can only introduce $[\alpha \text{ case}]$ complements, i.e. they appear only in rule 1 and have the number index 1 (cf. G. @ P. 1982:16-17). This, apart from reinforcing our claim that the consistive complement, as a strictly subcategorized noun, is a sister of N, has the following

interesting complication. Since measure nouns have the number index 1, it is expected that an *apo*-phrase after such nouns will yield a bad sentence. Yet, this is not exactly so. The resulting strings are bad in the intended meaning only. But they can, nevertheless, be interpreted by the semantic rules in a completely different way than when the *apo* phrase occurs after the suitable (i.e. correctly numbered) head noun. Accordingly, *ena kuti apo biskota* (a box of(from) biscuits), since it cannot mean a box made of biscuits (consisting of biscuits) means a box empty now, but which used to contain biscuits; similarly, *ena flitzani apo krema* (a cup of cream) etc. But this must be considered as a semantic matter*: *ena plithos* (a crowd) can consist of *anthropus* (people), but *ena flitzani* (a cup) cannot consist of *krema* (cream); so *ena dhokhio apo atsali* (a pot of steel) is not semantically parallel to *ena kuti apo biskota* (a box of biscuits). Along these lines, we can say that the traditional distinction drawn between expressions of content or constituent parts on the one hand and of material on the other - both expressed by *apo*-phrases - is again a matter of semantic interpretation, since considerations of the denotation of particular words are also involved - not just subcategorization possibilities. Thus, *ena aghalma* (a statue) is made of *brudzo* (bronze) - expression of material - but *ena plithos* consists *apo anthropus* (expression of content).

Something similar happens in the case of genitives after certain nouns (e.g. measure or unit nouns); since *ena potiri neru* (a glass water [gen]) cannot mean a glass

*Furthermore, the fact that the preposition *apo* is used for a great range of relationships between the head noun and its complement (for example it is used to express what the two prepositions *of* and *from* express in English) might be relevant here.

with water or a glass made of water, or water of a quantity equal to a glass, it means simply a 'waterglass'; the genitive in this case expresses what in traditional grammar is called *aim* or *property*.

3.2 Some additional evidence for the consistive reading

Having seen the basic reasons for considering strings like *ena plithos anthropi*, *ena buketo luludhya* etc. as structurally ambiguous, and having presented the so-called 'noun-complement' or 'consistive' reading of the above phrases, which exists in parallel with the pseudopartitive or measure reading, we shall now present some additional evidence for the suggestion that phrases like the above have a noun complement reading; then we shall outline the problems that remain.

In II 2.3.2 we said that the quantificational character of measure phrases in pseudopartitives is also seen by the fact that they form answers to quantificational questions. Correspondingly, the consistive interpretation accounts for the following question:

37. - Ti buketo aghorases ? Gharifala i frezes ?
what bunch bought-2nd s.? Carnations or frezes?
What bunch did you buy ? Carnations or frezes?

a - Gharifala
Carnations

In 37 the question asks about the kind (cf. ti (buketo)) of complement; thus, the answer involves only the complement, the head is taken for 'granted' as it were. Not only that. The complement can be emphatically (or

contrastively) stressed in the same way as the measure phrase in the pseudopartitive:

38. Ena buketo gharifala
(cf. Ena buketo apo gharifala, okhi apo frezes)
a/one bunch carnations
A bunch of carnations (not of frezes)

It is interesting that the structural ambiguity of 'appositional' NPs of the sort discussed is not always matched by a clear semantic ambiguity. But, given the facts cited above, this lack of semantic ambiguity is rather 'apparent' (cf. Akmajian-Lehrer 1976).

3.3 Remaining problems

The problem that our analysis cannot solve is represented by the following two examples:

39. Dyo bukalya ladhi khithikan
two bottles oil were spilt
Two bottles of oil were spilt
40. To bukali to kراسي itan rosé
the bottle the wine was rosé
The bottle of wine was rosé

In 39 verb agreement is determined by the measure phrase *dhyo bukalya* (plural), and only selectional restrictions are determined by what must be considered as head of the NP (39 is read as pseudopartitive). In 40 the definiteness of the whole NP suggests that we are here dealing with the noun complement (consistive) structure, yet selectional restrictions are determined by what this

structure requires to be the complement (*krasi-wine*). Is, then, our assumption about a separate pseudopartitive and a 'noun complement' structure wrong? Before we abandon our previous analysis, it is worth mentioning two related views on some 'idiosyncracies' of selectional restrictions concerning English. Jackendoff (1968) and McCawley (1968) challenge the traditional view that selectional restrictions hold between the main verbs and the heads of the NPs associated with them, arguing that the whole NP and not only its head is relevant in determining selectional restrictions. So, in the phrase *My buxom neighbour is pregnant*, features from the modifier combine with those of the head and selectional restrictions are stated through this combination. Akmajian and Lehrer (1976) express a similar view, in a more specific way. With regard again to the above sentence, it is assumed that the gender feature has been transferred from the modifier to the head noun, only because the head in this case is lexically unspecified as far as this feature is concerned. *Neighbour* is supposed to contain a gender feature, but this is lexically unspecified, therefore *neighbour* can receive this feature from its modifier.

This view could explain the oddity of 39: we can still consider that as a pseudopartitive, where the head (*ladhi*) determines selectional restrictions. Of course, neither of the nouns involved is lexically unspecified for a feature that the other noun contains, but *ladhi* has the feature [+Mass] and mass nouns are assumed to be lexically unspecified for number (rather than totally lacking this feature). So, the plural quantificational modifier (*dhyo bukalya*) assigns to the unspecified head the syntactic feature [+plural].

However, such a view cannot easily account for 40. The head here is not unspecified either for the feature

[+SOLID] or for [+COUNT] (and *rozé* is, of course, the colour of the wine not of the bottle). Here it seems that McCawley's view is more relevant, in that we have rather a combination of features. If this is true, it is interesting in that it shows that the head can receive features not only from its specifiers but also from its complements - i.e. from any of its modifiers. On the other hand, cases like *to kuti ta spirta teliosan* (the box 3rd s. the matches 3rd pl. finished 3rd pl.) must be seen as an instance of the '*constructio ad sensum*', since the head noun is a collective (or group) noun (cf. Tzartanos:44), and, in addition to that, the complement denotes the units (hence in plural) out of which the head noun consists. We may assume that Jackendoff's-McCawley's view is a refined formulation of the phenomenon of '*constructio ad sensum*'. The above facts concerning examples 39-40 show how difficult it may prove to be to base arguments for structural ambiguity exclusively on matters of selectional restrictions. Selectional restrictions can be used towards this effect, only if *there is independent evidence* suggesting the existence of structural ambiguity, such as verb agreement and cliticization (or pronominalization in general). Accordingly, selectional restrictions, verb agreement and cliticization are not of equal value with respect to the establishment of structural ambiguity: verb agreement is certainly more conclusive, but the combined effect of all three processes is quite illuminating.

B. THE PARTITIVE CONSTRUCTION

1. Partitive NPs in English

1.1 The syntactic and semantic function of the partitive phrase.

The definite *of*-phrase occurring after quantifiers, the so-called group nouns (a *group*, a *number* etc.), the demonstratives (*this*, *that*), numerals, the interrogative *which* and superlatives is called *partitive*. The following trees are proposed by Jackendoff for partitive noun phrases

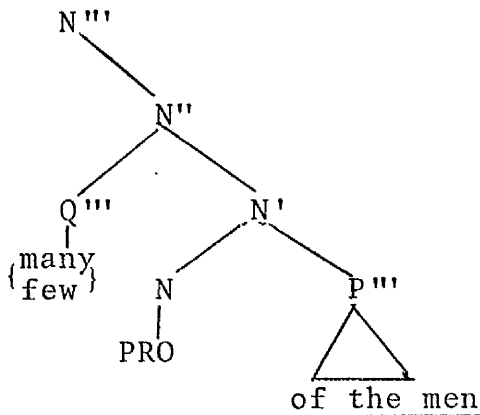
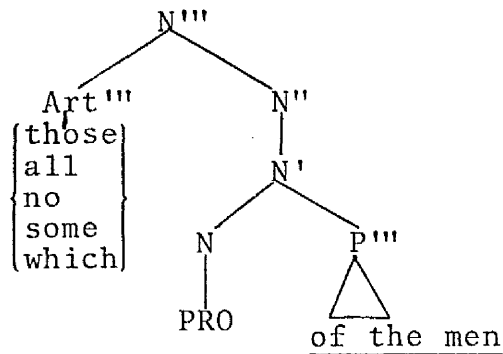

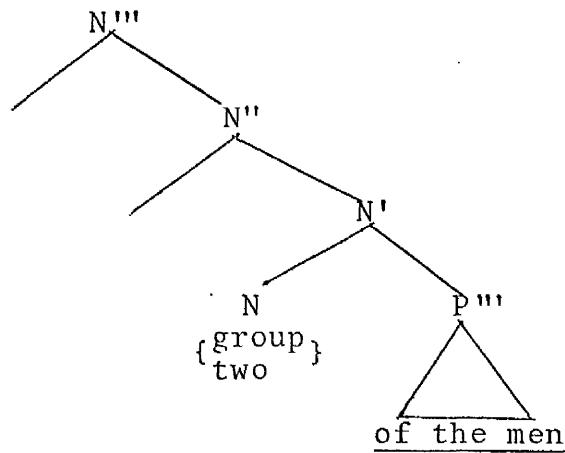

Clearly, any of the specifier nodes can be lexically filled in front of the partitive phrase. The empty node PRO in the first two trees is interpreted by a projection rule that assigns to it an interpretation like 'unit(s)' or 'amount' (in the case of mass nouns), when this node is immediately to the right of any of the articles that govern partitives. This rule is stated as:

$$\text{PRO}_N \rightarrow \text{UNIT(AMOUNT)} / \begin{matrix} X \\ [+PARTITIVE] \end{matrix} \quad \text{--- (Jack. 1977:110)}$$

This PRO is well justified. It is reminiscent of the missing head noun, lexically identical to the noun of the complement, and is independently needed in other constructions too, such as N'-Anaphora, N'-Gapping, the Postposed Genitive. These structures that contain a PRO head are accompanied by an obligatory rule assigning the feature [+substantive] to the article that precedes PRO (cf. Jackendoff 1977:114-117). It is worth mentioning that the idea expressed by those who favoured the earlier transformational analysis of partitives - i.e. that full lexically specified NPs are involved in the partitive construction - is reflected in the use of the empty node PRO⁵. Another point can be made about PRO. The projection rule mentioned above is an operational test for

distinguishing genuine partitives from constructions close to them, but presumably not partitives (cf. note 5, argument 4). These are *of*-phrases not governed by any of those items introducing partitives, so the projection rule mentioned earlier cannot apply. These phrases usually occupy sentence initial position. It is claimed (in particular by Akmajian and Lehrer (1976)) that such phrases are generated 'in place' and not preposed from somewhere within the main clause, for the reason that there is no position within it from which the *of*-phrase could have been extracted. Accordingly, in the sentence

1. Of the cars on display, I prefer the Alfa Romeo
the initial PP is generated *in situ*, under S and not under an NP, since, obviously, there is no item lexically marked to govern a partitive (or indeed any PP).

What, then, is the function of the partitive *of*-phrase? "It designates a set out of which certain individuals (or a certain subset) is selected" (Jack. 1977: 108). Or, "it provides a reference class, a delimitation of the 'universe' of which the referent of the first NP is a member; hence the name Partitive" (Stockwell, Schachter, Partee 1973:119).

1.2 Properties of the partitive phrase

A characteristic property of the partitive is that it obeys the Partitive Constraint, a semantic constraint which refers to semantic functions in the specifier system and not to syntactic positions. This constraint is stated as follows:

"In an *of*-N" Construction interpreted as a partitive, the N" must have a demonstrative or genitive specifier"

(Jackendoff 1977:113). This blocks bad strings like:

2. * $\begin{matrix} \text{A group} \\ \{\text{Many}\} \end{matrix}$ of some men

while allowing for

- 3.a. Many of the men
b. A group of his friends

According to Selkirk this is a partitive recursion constraint, in that it allows for an infinite number of *of-N* phrases (cf. argument 10 of note 5).

A characteristic common to quantifiers and group nouns when they introduce partitives is that if they are preceded by the definite article, then a RRC is necessary; cf.:

- 4.a. *The $\begin{matrix} \{\text{group}\} \\ \text{many} \end{matrix}$ of the men
b. The $\begin{matrix} \{\text{group}\} \\ \text{few} \end{matrix}$ of the men that you met

Furthermore, Jackendoff claims that this relative clause defines the group noun (or the quantifier) rather than the noun of the complement. This is clear from the fact that when the *of*-phrase is preposed (e.g. topicalized), the restrictive relative cannot be attached to it.

- 5.a. *Of the men that you met, the $\begin{matrix} \{\text{group}\} \\ \text{many} \end{matrix}$ are not here anymore
b. Of the men, the $\begin{matrix} \{\text{group}\} \\ \text{many} \end{matrix}$ that you met are not here anymore

when the head noun is indefinite, can contain restrictive relatives at two positions - one belonging to the head, the other to the complement noun. See the following relevant structures:

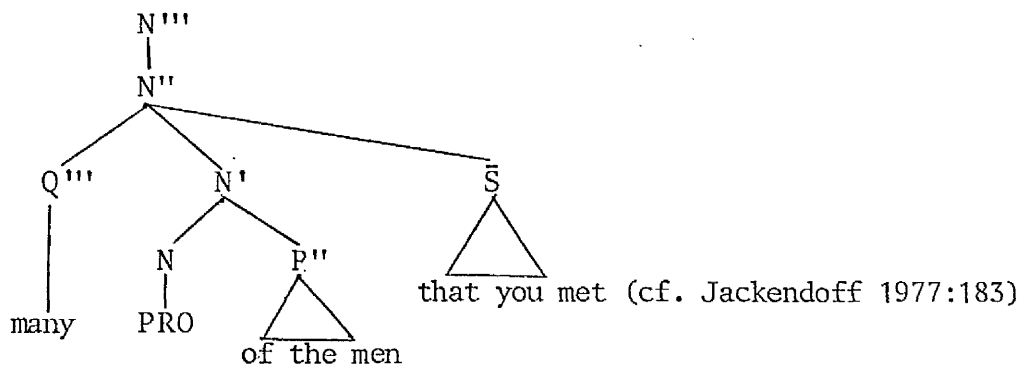
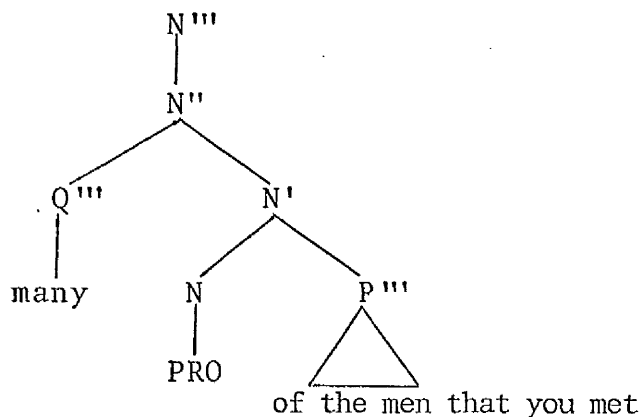

Evidently, then, the difference between these two structures and the corresponding ones with a definite head, must be due to the definiteness of the head of the latter. Moreover, the *of*-phrase preposing test (cf. p. 214) does not seem to be reliable: in partitives this can in general be preposed, but the ungrammaticality of 5a (vs. the grammaticality of 5b) may be due to a situation in which the *of*-phrase cannot be preposed at all, rather than to a single attachment of the RC, which may seem counterintuitive. As we shall see below, in MG the inability of the

prepositional complement to be preposed in 'partitives' with a definite head noun, suggests strongly that the whole construction should get a consistive reading rather than a genuine partitive one. In other words, the above mentioned function of the partitive as a picking out or selection of a set seems to cease; it starts to exist again if there is a second restrictive relative which unambiguously modifies the higher NP (i.e. the head) as in 7 and 8-9 below:

8. The only (one) of the men who like bowling who likes knitting..
9. Of the men who like bowling, the many who like knitting are the happiest (Jackendoff 1977:185).

Notice here that the order of appearance of RRCs is a 'mirror' order of the constituents to which they refer (cf. arguments 5-6, note 5) and, at the same time it confirms the NP-Complement theory. Examples like 8-9 suggest that the RC in 4b can be still understood as modifying the complement noun, but in this case the whole NP is unlikely to be interpreted as partitive, just because the RC does not contribute to picking out a subset of a class of referents but rather specifies the kind of X that constitutes a certain group or majority; instead, it may be interpreted more naturally as 'consistive', therefore the *of*-phrase with its modifying clause is not extraposable, as it is not extraposable as a consistive complement (cf.??Of (the) flowers a bunch). But if the RC is understood as referring to the higher NP (the head), then this picks out a group as a subset of a set and the interpretation of the whole construction as partitive is again possible. Similar is the situation in 8 and 9, where in addition to the RC referring to the lower NP, there is also a RC referring to

the head, so that the latter assumes again its function as an introducer of a partitive phrase.

It is worth stressing that some other introducers of partitives, which are inherently definite, do not parallel quantifiers and group nouns with regard to the attachment of the RC*; Such are superlatives and personal pronouns, cf.:

- 10.a. Of the men that you met, the tallest are not here any more
- b. Of the men, the tallest that you met are not here any more
- 11. Of the men who bowl regularly, the best are the happiest
- 12.a. Of the men that you met, only one voted 'no'
- b. Of the men, only we that you met voted 'no'

Why are 10a, 11 and 12a grammatical, in contrast to 5a? The only explanation would force us to consider the initial *of*-phrase in these examples as generated 'in place', i.e. not as partitive. But, on the other hand, this would appear artificial, for the NPs of the sentences happen to be exactly those that can govern a partitive complement.

After all, then, the ungrammaticality of 5a may be due only to the fact that the use of the definite article with the head noun is not justified, there is no reason for the use of the definite article because the noun is not specified. The RC is a complement which "satisfies the constraint on use of the definite article" (see Jackendoff 1977:177 onwards), thus 5b is OK.

*I owe this comment and the relevant examples to Dr. K. Mickey.

As a final property of the partitive phrase, we shall refer to the characteristic of all items introducing partitives of allowing the partitive complement to undergo Extraposition from NP, a rule which regularly moves N' Complements (cf. Jack. 1977:107) (hereafter E-NP). Cf.:

- 13.a. $\left\{ \begin{array}{l} \text{A lot} \\ \text{Much} \end{array} \right\}$ of the leftover turkey has been eaten
b. $\left\{ \begin{array}{l} \text{A lot} \\ \text{Much} \end{array} \right\}$ has been eaten of the leftover turkey

This extraposition obeys subadjacency⁶, given the view that NP is a bounding node, cf.:

- 14.a. $\left[\left\{ \begin{array}{l} \text{A lot} \\ \text{Many} \end{array} \right\} \right]$ $[t]$ were asked $\left[\begin{array}{l} \text{of those questions} \\ \text{PP} \\ \text{concerning electromagnetism} \end{array} \right]$
b.* $\left[\left\{ \begin{array}{l} \text{A lot} \\ \text{Many} \end{array} \right\} \right]$ of $\left[\begin{array}{l} \text{those questions} \\ \text{NP} \end{array} \right]$ $\left[\begin{array}{l} t \\ \text{NP NP} \end{array} \right]$ were asked $\left[\begin{array}{l} \text{concerning electromagnetism} \\ \text{PP} \end{array} \right]$

14 b is bad because subadjacency is violated (cf. below, p. 220). In sum, partitives behave like ordinary N' complements with regard to the proper order of restrictive relatives (the relative as N' complement following the partitive complement), the preposing of the *of*-phrase and Extraposition from NP.

Now, we shall briefly see how the partitive construction is distinguished from the 'pseudopartitive' and 'noun complement' one, concerning, always, English.

1.3 Partitive versus Pseudopartitive construction

Partitives and Pseudopartitives had been long considered as sharing the same structure - their only difference

being the indefiniteness of the 'pseudopartitive complement' (*a bunch of the flowers/a bunch of flowers*).

The first argument for a basic structural difference between the two constructions concerns the application of the Partitive Constraint. Clearly, this does not apply in 15-16:

15. A bunch of flowers

16. A gallon of wine

because they are grammatical despite the fact that the *of*-phrase is indefinite. Moreover, bad sequences like:

15.a. *A bunch of some flowers

16.a. *A gallon of much wine

are ruled out by the specifier constraint, given that *a bunch* and *a gallon* are specifiers. Consequently, 15-16 have a structure different from that of partitives, any resemblance to which is only apparent - hence the name 'pseudopartitive' for sentences like 15-16. The assignment of different structures to partitives and pseudopartitives automatically explains the difference in:

a. the application of E-NP; cf.:

17.* A number was asked of questions

18.* A lot has been eaten of leftover turkey

What has been 'extraposed' in 17-18 is not a complement but the head itself. The tree diagram below shows that:

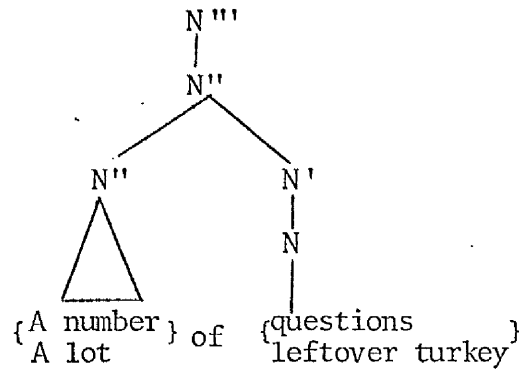

To the ungrammaticality of 17-18 the grammaticality of 19-20 can be contrasted:

- 19. A number of stories soon appeared about Watergate.
- 20. He gave a rather large number of books to Mary by famous authors.

In 19-20 the noun following *of* is the head, and the PP which is extraposed is a complement of N, see the following structure:

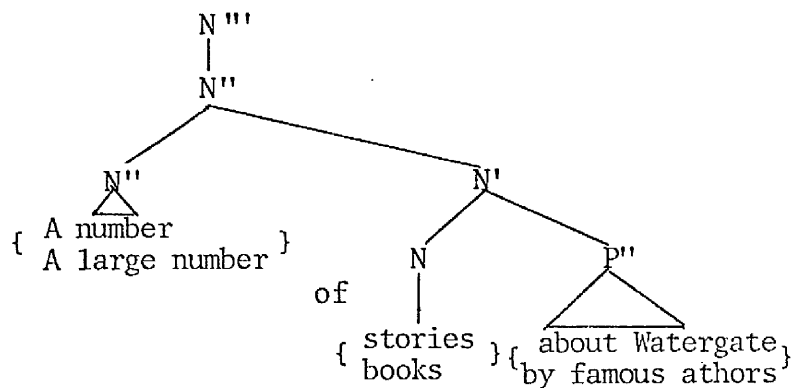

Subjacency is not violated because the PP is extraposed from a single NP. If 19-20 were partitives, the same PPs that are extraposable now would not be expected to move at all, since subjacency would then be violated (cf.*?)

a number of the stories appeared about Watergate). In the following structure the circled nodes show the existence of *two* NPs - i.e. of two bounding nodes. The extraposition of the lower P''' violates subadjacency (cf. Akm. @ L. 1976), since that P''' moves out of two bounding nodes

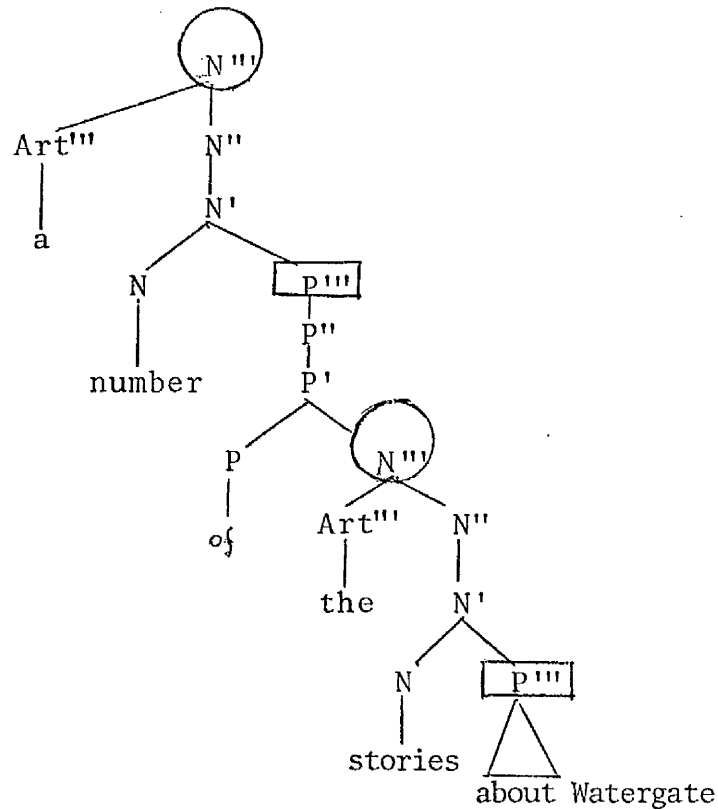

b. The interpretation of non-restrictive relative clauses. Cf.:

21.a. She bought him a number of daffodils,
only two of which were faded

b. She bought him a number of those daffodils,
only two of which were faded

In 21 a the appositive relative is not ambiguous, since in *a number of daffodils* there is only one N''' to which

it can be attached, whereas in 21b it can be attached either to *a number* or to *daffodils*, because *a number of those daffodils* contains two N''' (the head and the complement) to which the relative clause can be attached.

- c. The optionality of *of*, which can never be omitted in partitives (e.g. **a number those daffodils*), but can be omitted optionally in pseudopartitive constructions, cf.:

22. A couple (of) sheets

23. I met a larger number of high school students than I did (of) college students

The omission of *of* is freer in American English; it is very common in recipes, as shown in 24:

24. A pound butter

One pound flour (cf. Selkirk 1977)

while in British English it often becomes [ə] phonetically. In sum, the partitive construction is recursive, right-branching and contains an NP within an NP. The pseudopartitive construction is not recursive and is a simple NP, since it does not contain an NP within another NP. The difference between partitives and pseudopartitives is a crucial one. Moreover, both are distinguished from the noun complement construction. We have already considered the distinction between pseudopartitives and 'noun complements'. Now we shall briefly consider the distinction between a partitive and other (e.g. consistive) N'-complements.

1.3.1 Is the partitive construction fundamentally different from the so-called noun complement (consistive) one ?

For one thing, these cannot differ radically, e.g. in the way that pseudopartitives differ from noun complements, because both are considered by Jackendoff (1977) as complements of N. We cite an illuminating comment of his (1977:121 note 10). "Note that there is another construction, exemplified by *a group of three men*, in which the *of*-phrase does not contain a demonstrative specifier. But this *of*-phrase does not have a partitive interpretation, since *a group of three men* means not a group taken out of three men, but a group consisting of three men. Hence the Partitive Constraint does not apply and a non-demonstrative specifier is permitted... In fact the consistive reading seems to require a nondemonstrative specifier and thus is mutually exclusive with the partitive reading. The Partitive Constraint may thus in fact be part of the structural description of the semantic rule that differentiates between these two readings of the N' Complements".

I think these remarks are the key to the issue of determining in what respects the partitive and noun-complement phrases are different. Given that both are N' Complements, the only certain way to differentiate them is the Partitive Constraint. Remember, however, that in certain environments a string can be read in both ways, as either partitive or consistive (see p.217). If there is nothing in principle to block a definite specifier in the consistive complement - and it seems unnatural that there should be - the complement can appear as definite and then it can also be read as partitive. In fact, we saw that in MG the complement is required to be definite if the head itself is definite (cf. examples

31b'-32b1, p.203-204). However, I believe that in certain of these ambiguous definite *of*-phrases, there is at least one method of disambiguation. This concerns the head noun and its subcategorization properties. More accurately, not every noun can be followed by a consistive complement. For example, *group* is the noun *par excellence* which requires a consistive complement, in contrast with the quantifiers *many*, *few*, *some*, which require rather a partitive complement. We have already proposed a means by which the subcategorization restrictions of nouns belonging to the same structure can be met - see p. 205.

Selkirk's argument that partitive and noun-complement phrases are structurally different is based again on phenomena differentiating the head of the relevant structures - such as selectional restrictions, verb agreement, Extra-position from NP. But since her examples are not clear-cut for English native speakers and her conclusion is that the head is different in partitive and noun-complement constructions (i.e. that in *a bunch of the flowers*, the head is the *flowers* if read as partitive, whereas *a bunch* is the head if read as noun-complement), her claims are irrelevant to our discussion and not worth mentioning in detail.

2. Partitive Phrases in Modern Greek; properties of the partitive construction

Partitive phrases in MG are exemplified as follows:

25. Poli apo tuz mathites
Many of the students
26. Tris apo tuz mathites
Three of the students
27. Mnya omadha apo tuz mathites
One group of the students

The obligatorily definite *apo(of)*-phrase occurs after⁷

- a. Quantificational adjectives and articles (cf. p.48-49) apart from *olos* (all).
- b. Demonstratives (e.g. *aftos* (this)), *wh*-interrogatives (*pyos* (which)), *posos* (how much).
- c. Numerals.
- d. The superlative degree of adjectives: e.g.

{ 0 omorfoteros } apo tuz mathites
{ 0 pyo omorfos }
the most beautiful of the students

- e. Nouns forming 'measure phrases', like *kilo* (kilo), *metro* (meter), *buketo* (bunch) etc.
- f. Collective, mass or 'group' nouns, subdivided in
 - i. collective nouns proper (like *parea* (company), *grup* (group) etc.).
 - ii. partitive nouns (like *meros* (part), *tmima* (section)).
 - iii. nouns denoting an indefinite collection of things, called also mass or consistive nouns (like *plithos* (crowd), *lefusi* (bunch), *zminos* (swarm)).

The main ^{fi}identificatory characteristic of the prepositional partitive phrase is its *definiteness*. This is due to the Partitive Constraint, expressed in the same way as for English partitives. If this constraint applies, grammatical strings like 25-27 above are generated. If it does not apply bad strings like the following are generated:

28. *Poli apo lighus mathites
*Many of few students
29. *Poli apo mathites
*Many of students

30. *Tris apo arketuz mathites
*Three of several students

Contrast 28 and 30 to 31:

31. {Lighi}apo tus {pende} mathites
 {Tris} {polus}
 {Many} of the {five} students
 {Three} {many}

Or, if the introducer of the partitive is a group or consistive noun and the Partitive Constraint does not apply, then the resulting phrases are interpreted exclusively as consistive:

32. Ena grup apo poluz mathites
 One group of many students
33. Ena lefusi apo khilyus alites
 One bunch of thousand vagrants
34. Ena zminos apo ekato akridhes
 One swarm of hundred locusts⁸

Examples 32-34 are interesting in two respects. First they lend support to Jackendoff's view that the application (or non-application) of the partitive constraint differentiates the partitive and consistive complement, since the latter usually appears with an indefinite specifier (see p.224). Second, it reinforces our proposal about differentiating two complements referring to the same head noun in terms of the subcategorization properties of the particular head noun (cf. p.205). Thus, contrasting 28-30 to 32-34, we see that it is the particular items which appear in head position that are responsible for the difference in grammaticality between

28-30 on the one hand and 32-34 on the other.

With regard to the empty head PRO as established in the case of English partitives, it seems that it gets more support from MG. In fact, by establishing this empty head we can account for agreement phenomena, which otherwise would be puzzling. Cf.:

35. {Kathenas} apo tuz mathites
 {Liyi
 {Everyone} of the students
 {Few

36.a. Liyi apo ti supa
 {little} of the soup
 {some

b. Lighos apo ton gima
 some of the minced meat

In 35-36 we see that the specifier which introduces the partitive complement agrees in gender (and number⁹) with the noun of the partitive complement. But we have already said that specifier elements obligatorily agree in all syntactic features with their heads. Since the noun of the *of*-phrase belongs to the complement we must look elsewhere for the head. But the head appears as obligatorily absent from the partitive construction, cf.:

37. *{Kathenas mathitis} apo tuz mathites
 {Liyi mathites

38.a.* Liyi supa apo ti supa
 b.*Lighos kimas apo to gima

37 and 38a-b show first that the head noun is obligatorily missing and, second, that this is responsible for the features assigned to the specifier, according to the

Control Agreement Principle. Now, the fact that the head agrees with the noun of the complement is common in MG and must be considered as a language particular phenomenon, accounted for by the FFP. We saw in II.3.2 that this was also the case when the complement was a plain adjective (or adjective phrase), only that there the agreement was in all three features, gender, number, case. In the case of the partitive complement, since the noun of the complement is the object of a preposition (here *apo*), it is marked necessarily as [+accusative]. Consequently, agreement between this and the head is just in gender and number. With regard to number agreement, an exception appears when the numeral *enas* (and the universal quantifier *kathenas*, which morphologically consists of the quantificational adjective *kathe* and the numeral *enas*) and the NP *o monos* ('the only') are the head of the partitive construction. These two items do not agree in number with the noun of the complement when it is in the plural¹⁰. Incidentally, we notice that verb agreement in the latter case reinforces the view that the first noun of the partitive construction is the head of the whole NP. Cf.:

39. *Enas apo tuz mathites irthe*
One of the students came (3rd s.)

Coming back to the question of the head, we saw that it is necessary to establish an empty PRO, apart from the case of group nouns, of course, where the head is the group noun itself. Finally, the empty head is semantically interpreted as denoting a unit (or units), or an amount in the case of mass expressions.

originally under V" - as the prepositional phrases in the following examples clearly are:

44. Apo ta aftokinita tis ekthesis protimo ta Fiat
of the cars (of)-the display prefer-I the Fiats
45. Apo ta epipla tu dhomatiu, axizi to karidhenyo
of the furniture (of)-the room, has value the nut
trapezi
table
Of the furniture in the room, the nut table is
of some value

As we said earlier about English partitives, an operative test for distinguishing the two cases is the existence of the empty head, or, more generally, of one of the items that can introduce a partitive. In 40-42 there are such items (*pende*, *poli*, *omadha*). But in 44-45 there are not - consequently, the prepositional phrases there cannot be partitives. But are those in 40-42 *obligatorily* interpreted as partitives? This is rather a difficult question, for things get obscured if the introducer of the complement is *definite*. Consider the examples below:

46. I {poli }apo tuz mathites
 {pende }
 The {many} of the students
 {five }
- 47.a.*I omadha apo tuz mathites
 the group of the students
- b.*?To tmima apo tuz mathites
 the section of the students
- c.*?To plithos apo tuz mathites
 the crowd of the students

d.*0 arithmos apo tuz mathites
the number of the students

Before explaining the ungrammaticality of 47a-d, we can say that the partitive phrase in 46 can be preposed:

46'. Apo tuz mathites, i {poli } ...
pende }

But the same in 47a-d results again in ungrammaticality:

47.a' *Apo tuz mathites, i omadha...
b' *Apo tuz mathites, to tmima..
c' *Apo tuz mathites, to plithos...
d' *Apo tuz mathites, o arithmos...

Why do group nouns and quantificational adjectives (or numerals) not behave the same with respect to the topicalization of the partitive complement ? Is there any way to improve the situation in 47(a-d, a'-d') ? There are two ways, each showing two different things. So, first, the ungrammaticality of 47(a-d) can be eliminated if the definite *apo*-phrase is replaced by a definite genitive. But this genitive cannot be partitive in this environment (see note 7), with the exception of 47b, because group or collective nouns do not subcategorize a partitive genitive. On the other hand a consistive genitive does subcategorize these nouns. We may, then, conclude that the definite *apo*-phrase in 47 renders the whole relevant phrase odd, since its partitive reading is overlapped or confused with a consistive reading. Therefore these two 'readings' are mutually exclusive after certain head nouns the subcategorization properties of which allow for both a partitive and a consistive prepositional phrase. It is interesting that a genitive in 47b is most probably interpreted

as partitive, in contrast to the genitive in 47a and 47c, since the head noun is a partitive noun, which normally is not followed by an expression of content. Notice on the other hand the complete ungrammaticality of 47d, in which the definite head noun can only introduce a consistive complement (in the genitive case) (*o arithmos ton mathiton*), i.e. a partitive reading here is excluded, due to the definiteness of the head. Remember that we said earlier that 31b'on p.203 is odd, for the reason that it tends to be interpreted as partitive. Now, we can be more precise and say that the oddity of such phrases is due to the fact that there is a conflict between the subcategorization properties of the head noun and the type of complement it introduces (in particular, a definite *apo* phrase used both as a partitive and as a consistive complement).

2.1.1 Restrictive Relatives in the Partitive construction

The second way of bringing 47a-d back to grammaticality is the addition of a restrictive relative clause¹¹. We mentioned that this is obligatory in English for both definite quantifiers (and numerals) and group nouns. Yet, in Greek 46 seems OK. But 47(a-d) rather require a relative clause, cf.:

48.a. I omadha apo tuz mathites pu prokhorise
sti vuli
the group of the students that proceeded
to-the parliament

b. To tmima apo tuz mathites pu prokhorise
sti vuli
the section of the students that proceeded
to-the parliament

- c. To plithos apo tuz mathites pu prokhorise
sti vuli
the crowd of the students that proceeded
to-the parliament

The same holds true if the head is the demonstrative *aftos/ekinos* (e.g. *Afti* apo tuz mathites pu petikhan stis exetasis 'Those of the students that succeeded at the exams'). The underlined head and the verb of the relative clause show clearly which noun the RC refers to: since verb agreement holds between the head of the whole NP and the verb of the RC, the RC belongs to the head and not the complement. We should notice that the restrictive relative is in its expected position as a complement of N' (see p. 355), it follows complements of N, assuming, in line with Jackendoff (1977:ch. 5), that partitives are functional arguments of nouns. Compare 48a to the ungrammatical 48a').

48.a' *?I omadha pu prokhorise sti vuli apo tuz
mathites...

Also, if a restrictive relative is attached to the complement (cf. below), the position of the relative of the head is again the expected one: it follows the whole complement of N:

48.a'' I omadha apo tus aperghus pu prokhorisan
the group of the strikers that proceeded
sti vuli pu singrustike me tin astinomia
to-the parliament that conflicted with the Police.

My assumption is that the definite head in 47a-d had a unique reference, which forced the complement to be read as consistive; in other words, the *apo*-phrase was what 'supported' the definite article.

This becomes even clearer if a restrictive relative is attached to the complement (i omadha apo tus mathites pu prokhorisan sti vuli, the underlined constituents show verb agreement). But if a relative clause is attached to the head, then the definite article of the head depends upon that RC - after all partitive complements appear independently of the definiteness of the head noun - and through it the head can regain its 'picking out' or partitive function expressed by the partitive complement¹², cf. the question:

49.a.—Pya omadha apo tus mathites nikise sto deliko?
which group of the students won at-the final
(game)?

b.—I omadha pu theorite kaliteri
the group that is considered best

The above remarks do not strictly apply in the case of an empty head - i.e. in the case of numerals, quantificational adjectives and articles followed by an empty head - precisely because the empty head presupposes identity of the head and the noun of the complement. In the case of group nouns the head position is occupied by that noun, which is different from its complement. Thus, 46 is acceptable without a RC being obligatorily attached to the (empty) head. In addition to this, the *apo*-complement here is unambiguously partitive, for numerals and [+Q] adjectives are not followed by consistive complements.

To return to our primary question, that of whether or not the partitive phrase can be preposed (topicalized), in particular why 47a'-d' are bad, we cite the following examples in which a restrictive relative is attached to the group noun:

50.a.??Apo tuz mathites, i omadha pu prokhorise
sti vouli..

b.??Apo tuz mathites, to tmima pu prokhorise
sti vuli

c.??Apo tuz mathites, to plithos pu prokhorise
sti vuli

The double question mark in 50(a-c) shows that the addition of the relative clause to the topicalized version of 47(a-c) does not alter essentially the grammatical status of 47(a'-c'), as that would be expected. Curiously, though, if a restrictive relative is attached to the partitive complement (see note 11) the above strings become good:

51. Apo tuz mathites pu aperghusan, i omadha pu
of the students that were on strike, the group that
piye ston ipurgho...
went to-the minister...

Thus, unlike in English, it seems that a restrictive relative is obligatory also in the partitive complement, at least if there is any ambiguity between a partitive and a consistive reading of that complement.

2.1.1.1 Conclusion

All the above show, I think, that maintaining that the partitive prepositional complement can be unconditionally topicalized runs into serious difficulties. There is clearly an asymmetric behaviour of quantificational adjectives and numerals on the one hand, and 'group' nouns on the other, with respect to allowing the partitive

complement they introduce to precede them. I have no definite answer to offer to account for all the conditions under which such a 'preposing' can take place, nevertheless, I believe that any further detailed analysis using the above discussion as a basis must turn on the justification of one of two solutions. Either that 'preposing' is not the case at all, therefore that the sentence initial prepositional phrase in 40-41 46'-47(a'-d') and 50(a-c) does not entail a dependency, which is rather counter-intuitive for 40-41, or accept an asymmetry between [+Q] adjectives (and numerals) and group nouns, when they are definite. In other words, claim that definite group nouns allow for their partitive complement to be topicalized under the condition that the latter is read unambiguously as partitive, which can be ensured by the suitable attachment of a restrictive relative clause - or in fact of any restrictive modifier, such as a prepositional phrase, a genitive or a definite adjective - which will block a consistive reading of the definite *apo*-phrase. Sometimes, the obligatory definiteness of the noun of the partitive phrase requires a restrictive modifier, too (cf. 51), unless the definite noun is contextually or pragmatically identified.

2.2 Verb Agreement in partitives

A final issue about partitives concerns verb agreement. Is that determined by what we have so far maintained to be the head of the partitive construction - i.e. the first noun ? Let us see the following examples:

- 52.a. Mnya omadha apo tus aperghus idhe ton ipurgho
b. Mnya omadha apo tus aperghus idhan ton ipurgho
One group of the strikers saw the minister
- 53.a. Enas apo tus aperghus pethane
b. *Enas apo tus aperghus pethanan
One of the strikers died
- 54.a. Poli apo to plithos milisan
b. *Poli apo to plithos milise
Many of the crowd spoke

Clearly, the head noun determines number agreement. However, it seems that when the head noun is a group or collective noun and the partitive phrase consists of a count noun in the plural, as in 52b, the verb can be in the plural, according to the '*constructio ad sensum*'; this happens, of course, in the case of collective nouns independently of the partitive construction (cf. Tzartzanos:44), but compare 52b to 55:

55. *Mnya omadha apo to plithos milisan
One group of the crowd spoke

where the noun of the partitive phrase is an uncountable (:mass) noun. So, what seems to be relevant to the partitive construction is the feature [+plur.] of the noun of the complement (the feature [+plural] [+count] is rather redundant since it is presupposed by the feature [+count] in the case of partitives). The function of the partitive complement requires it to be plural if it is count (cf. p. 212 and 213).

2.3 Partitive complements with a clitic pronoun

Before we complete this paragraph, we would like to refer to a partitive construction that involves the clitic form of the personal pronoun in the place of the definite *apo*-phrase. Thus, *some* of the N'' articles, traditionally included among the 'indefinite' pronouns (in our grammar marked as Art [+Q]¹³, cf. II.2.1.2) can also govern the genitive clitic pronoun instead of a definite *apo*-phrase. This must be rather considered as a 'reduced' form of those categories when followed by the definite pronoun *aftos*.
E.g.:

56.a. Kanis apo aftus dhen irthe
 none of these not came-3rd s.
 None of them came

b. Kanis tus dhen irthe
 none them(clit.) not came-3rd s.

57.a. Kathemnya apo aftes ekhi dhyaforetiko epangelma
 each one(fem.) of these(fem.) has different profession

b. Kathemnya tus ekhi dhyaforetiko epangelma
 each one(fem.) them(clit.) has different profession

(but not *meriki tus* (some them (clit.)), *arketi tus* (several them (clit.)), *poli tus* (many them (clit.)), *liyi tus* (few them (clit.))). It seems that of the N'' specifiers, only the so-called universal quantifiers can participate in this type of partitive construction. Now, of 'universal quantifiers', *olos* (all, every) can only be followed by the clitic pronoun in the genitive case, not by a partitive *apo*-phrase (see p. 226).

- 58.a. Oli tus irthan
all(masc.) them(gen.) came-3rd pl.
- b. Oles tus irthan
all(fem.) them(gen.) came-3rd pl.
- c. *Oli apo tuz mathites irthan
all of the students came-3rd pl.
- d. *Oli apo aftus irthan
all of these came-3rd pl.

Such a situation is expected and normal, for *olos* as a universal quantifier cannot denote partition¹⁴; rather, the clitic following it must be considered as a 'reduced' form of the definite noun phrase that follows *olos*, in contrast to 56-57(a) (cf. Tzartanos 1946:115).

- 59.a. Oli i mathites (cf. p. 147)
All the students
- b. Oli tus
all(masc.) them(gen.)
- c. Oles i yinekes
All the women
- d. Oles tus
all(fem.) them(gen.)

However, there is a problem with the case of the clitic pronoun in phrases like 59b and d. The clitic here is in the genitive, but the full NP in 59a and c is in the nominative. In the latter case *olos* is, of course, a modifier agreeing in the syntactic features with the head noun according to the Control Agreement Principle or the FFP. (For the positions of *olos*, which are the same as those of *aftos*, see II, note 49). In the former case the clitic is

the complement and *olos* agrees again with the head, which in this case is evidently empty, as we showed in §2 above. The fact that the head agrees with its complement in gender is a different matter and accounted for by the CAP. Now, apart from *olos* and the other quantificational articles we mentioned, numerals¹⁵ and the (universal?) *Kathenas* (Kathis) (see notes 13 and 14), when preceded by the definite article, can be followed by the clitic pronoun in the genitive case; e.g.:

- 60.a. Ke i dhyo tus milisan
and the two them(clit.) spoke
Both of them spoke
- b. O kathenas tus kani oti theli
the eachone them(clit.) does what wants-3rd s.
Each one of them does what he wants
- c. Ipe o enas tus :
said the one them(clit.):
Said the one of them:

60b and 60c are certainly to be considered as 'reduced' forms of the partitive phrase in which the definite noun is replaced by the definite pronoun *aftos*, e.g.

- 61.a. O kathenas apo aftus kani oti theli
b. Ipe o enas apo aftus:

But the clitic of 60a has a potentially ambiguous 'source': either a partitive phrase with the definite *aftos*, or, like in 59, a definite *aftos* in the nominative case - in both cases *dhyo* is a specifier under N' followed in the first case by a PRO head and in the second by a head marked as $\begin{bmatrix} +\text{pro} \\ +\text{def} \end{bmatrix}$ spelled out as *aftos*, e.g.:

62.a. Ke i dhyo apo aftus milisan

b. Ke i dhyo afti milisan

But *Kathenas* in 60b and *enas* in 60c exclude a source like 62b:

63.* 0 {*kathenas*} aftos kani oti theli
 enas

However, Tzartzanos adopts 62b as the source of 60a, although for 60b-c he adopts 61a-b. There is no reason given for this asymmetry. The genitive of the clitic pronoun following *oli* is called 'clarificatory' genitive (διασαφητικῆ-dhyasafitiki-γενικῆ), whereas the genitive¹⁶ of the clitic pronoun following *kathenas*, *kanenas*, *enas*, *alos* (other, other one) is called *partitive* genitive (Tzartzanos:113-114). The clarificatory genitive, obviously, has an 'appositional' construction as its source (cf. *oli i anthropi*, {*afti*} *i dhyo*, *i tris afti* - see p.149 and Appendix). I assume that the genitive of the clitic in 56b, 57b, 58a-b, 59b and d, and 60a-c is *partitive*, despite the non existence of 58c-d. Moreover, I do not think that anything important hinges on the characterization of this genitive. What is of real interest is just the existence of such sequences with a clitic pronoun in the genitive. We shall see that such clitics appear also in non-*wh* relative clauses because they exist independently in adverbial constructions in which a 'complex' adverbial is followed by a noun phrase (see p.298), so they must be accounted for on multiple grounds by the grammar. We shall deal with such clitics in detail in the Relative Clauses chapter, but here, before we see how we can generate them in connection with the *partitive* construction, we must first recapitulate the main characteristics of this construction

incorporating them in the relevant rules that are responsible for it.

2.4 Rules for partitives

We propose the following sets of rules:

$$(a) \left\{ \begin{array}{l} \left[\begin{array}{l} N'' \\ [e] \end{array} \right] \quad \left[\begin{array}{l} \text{Art} \\ [+Q] \end{array} \right] \quad \left[\begin{array}{l} N' \\ [e] \end{array} \right] \\ \left[\begin{array}{l} N' \\ [e] \end{array} \right] \quad \left[\begin{array}{l} N \\ [e] \end{array} \right] \quad \left[\begin{array}{l} P'' \\ [\text{def}] \\ [\text{apo}] \end{array} \right] \end{array} \right\}$$

$$(b) \left\{ \begin{array}{l} \left[\begin{array}{l} N' \\ [e] \end{array} \right] \quad \left[\begin{array}{l} A'' \\ [+Q] \end{array} \right] \quad \left[\begin{array}{l} N' \\ [e] \end{array} \right] \\ \left[\begin{array}{l} N' \\ [e] \end{array} \right] \quad \left[\begin{array}{l} N \\ [e] \end{array} \right] \quad \left[\begin{array}{l} P'' \\ [\text{def}] \\ [\text{apo}] \end{array} \right] \end{array} \right\}$$

$$(c) \left\{ \begin{array}{l} \left[\begin{array}{l} N'' \\ [e] \end{array} \right] \quad \left[\begin{array}{l} \text{Art} \\ [collect.] \end{array} \right] \quad \left[\begin{array}{l} N'' \\ [e] \end{array} \right] \\ \left[\begin{array}{l} N' \\ [e] \end{array} \right] \quad \left[\begin{array}{l} N \\ [collect.] \end{array} \right] \quad \left[\begin{array}{l} P'' \\ [\text{def}] \\ [\text{apo}] \end{array} \right] \end{array} \right\}$$

Set (a) generates partitives when the partitive complement is introduced by an N'' specifier, set (b) accounts for the partitive complement when introduced by N' specifiers and (c) when governed by a collective or group noun. The feature [def] under P'' accounts for the obligatory definiteness of the prepositional complement and is handled by FFP. I assume that a feature [pl(ural)] under the complement N'' (the object of P'') will account for the obligatory plural of it, in case it is marked as [+count] or [-mass] - i.e. the correct combination of the features [±count] and [pl(ural)] will give the desired

results. I also assume that [e], as a feature denoting an empty head, goes down to the head by the HFC. Concerning now the partitive genitive, which occurs only after partitive nouns (see f.ii, p.226), we can establish a metarule operating on the second (lexical) rule of set (c), when N' may be marked as [partitive], e.g.:

$$\begin{array}{c} \left[\begin{array}{c} N' \\ [part] \end{array} \right] \left[\begin{array}{c} N \\ [part] \end{array} \right] \left[\begin{array}{c} P'' \\ [def] \\ [apo] \end{array} \right] \Rightarrow \left[\begin{array}{c} N' \\ [part] \end{array} \right] \left[\begin{array}{c} N \\ [part] \end{array} \right] \left[\begin{array}{c} N'' \\ [gen] \\ [def] \end{array} \right] \end{array}$$

(cf. Gazdar 1979:3).

To come back now to strings containing a genitive clitic instead of a prepositional phrase: we must employ a meta-rule mapping rules containing a prepositional phrase to rules with a clitic in the genitive case, instead of that prepositional phrase. This metarule will apply to the second rule of the (a) and (b) set of rules for partitives on p. 243. For example, set (a) will be written as

$$(a) \left\{ \begin{array}{ccc} \left[\begin{array}{c} N'' \\ [e] \end{array} \right] \left[\begin{array}{c} Art \\ [+Q] \end{array} \right] \left[\begin{array}{c} N' \\ [e] \end{array} \right] \\ \left[\begin{array}{c} N' \\ [e] \end{array} \right] \left[\begin{array}{c} N \\ [e] \end{array} \right] \left[\begin{array}{c} N'' \\ [clit.] \\ [gen.] \end{array} \right] \end{array} \right\} ,$$

the relevant metarule giving the second rule of this set being accordingly:

$$\left[\begin{array}{c} N' \\ [e] \end{array} \right] \left[\begin{array}{c} N \\ [e] \end{array} \right] \left[\begin{array}{c} P'' \\ [def] \\ [apo] \end{array} \right] \Rightarrow \left[\begin{array}{c} N' \\ [e] \end{array} \right] \left[\begin{array}{c} N \\ [e] \end{array} \right] \left[\begin{array}{c} N'' \\ [clit.] \\ [gen.] \end{array} \right]$$

Of course, this metarule will not apply in the case of set (c), for genitival clitics do not appear after group/collective/mass nouns as alternatives of partitive *apo*-phrases.

2.4.1 A concluding note

With the above rules we end our discussion on partitive constructions. It is worth stressing the point that in MG there is no 'ambiguity'/confusion between the pseudopartitive and the partitive construction, because the partitive construction involves a complement consisting of a definite *apo*-phrase, or a definite genitive NP, or clitic pronoun in certain lexically determined cases, whereas the so-called pseudopartitive is an 'appositive' construction expressing amount; in fact, it exhibits a case of premodification.

Now, we shall briefly consider a construction often considered as 'apposition', but which clearly is not. This construction involves a complement consisting of a noun in the nominative case.

C. A NOMINATIVE (INDECLINABLE) COMPLEMENT

0. Introduction

MG examples corresponding to the English

The point zero

The term 'heavy water'

which, as said in the preceding Appendix, had been long considered as cases of apposition, but were shown by N. Burton (1975) to be simple cases of premodification (i.e. that *point* and *term* are attributive modifiers of *zero* and '*heavy water*' respectively), clearly show that the same claims cannot be made for such strings in MG, despite the fact that these, too, are considered as special cases of the phenomenon of 'apposition' ('parathesis') (cf. Tzartzanos 1946:59).

0.1 The data

The NPs we shall consider in this paragraph are illustrated below:

1. (To) tiri feta
(the) cheese 'feta'
2. To nosokomio 'Erithros Stavros'
the hospital 'Red Cross'
3. To puli aetos
the bird eagle
4. O vathmos midhen
the point zero

5. O paraghondas anthropos
the factor man
6. To 'MINOS'
the 'MINOS' (understood 'ship')
7. To 'OSA PERNI O ANEMOS'
the 'GONE WITH THE WIND' (understood novel)

We hope to make it clear that the second NP in the above examples is a type of complement marked as [+nominative].

1. The structure of [+nom] complements

Clearly, the article in 1-7 belongs to the first noun, since it agrees with it (only accidentally with the second, e.g. 5). Therefore, it is the first noun which must be considered as the head, the second being something else, most probably a kind of complement¹⁷. In these cases, this second noun is a kind of title, label or appellation in general. It serves to confine the potential semantic extension of the head noun (e.g. the particular cheese with the name '*feta*', not any cheese). Notice that such cases are considered as representatives of 'apposition' by Quirk and Greenbaum (1973:282-83). But the characteristic of the second noun in the examples 1-7 is that it is always in the nominative case and does not decline along with the head noun, whereas 'appositive' complements - we have already said - are [α case] complements. Cf.:

8. To simerino mathima ine ya to puli aetos
the today lesson is about the bird(acc.)
eagle (nom.)
9. I timi tu tiryu feta afxithike
the price (of)-the cheese(gen.) 'feta' (nom)
increased

10. I polisi ton vivlion ekdhoseos KEDHROS epese
the selling (of)-the books edition (gen.) KEDHROS(nom)
decreased

We see that the complement *remains* in the nominative case throughout the declension of its head. It is for this reason we call this sort of complement [+nom]. Another characteristic of [+nom] complements - in contrast with [α case] ones - is that they do not expand freely - in fact they cannot expand at all, despite the fact that the head is always definite ([α case] complements comply with the [\pm def] of the head). This seems rather natural if one bears in mind that these complements are generally labels or names of various things (books, films, ships, etc.). Just because of that, we should not confuse cases where a title which constitutes the complement has its own specifiers. These are fixed and form part of the particular noun, they do not belong, as it were, to the expansion of the node occupied by [+nom] complements. Furthermore, it often happens that the head noun is altogether omitted leaving its article behind. This is so, presumably, because in these cases the relationship between the head and the complement is unique, and the noun that introduces the complement can be 'recovered'. In other words, this happens when the complement is a well-known title or name. E.g.:

11. To 'MINOS'
The(understood plio:ship) MINOS
12. To 'A'
The(understood ghrama:letter) A

This may be a kind of ellipsis either of a particular word (as in 11-12) or of a more general expression like

to stikhio (the element), *i ekfrasi* (the expression) etc. Sometimes the remaining article of the head noun may be assimilated to the gender of the complement.

Alternatively, this may be considered as a case of nominalizing a non-NP, not as ellipsis. Namely, an item which is not originally an NP is nominalized by being attached the definite article, much as a nominalized clause is attached the article (e.g. *tu dhiyithika to pos vrethika stin Athina*). In that case, we do not have a complement construction (see below) but a simple NP. Now, if the nominalized item has no 'natural' gender, as it is the case of titles of books, films, buildings etc. or citations - usually contained in quotation marks - then the article attached is of neuter gender (*to/ta*) - as in the case of nominalized clauses, too - otherwise, the nominalizing article may be assimilated to the gender of the nominalized item; cf.:

13. Dhyavases $\left\{ \begin{array}{l} \text{ton FAUST} \\ \text{?to " } \end{array} \right\} ?$
read-2nd s. $\left\{ \begin{array}{l} \text{the(masc.) FAUST} \\ \text{the(neut.) " } \end{array} \right\} ?$
14. Dhyavases to OSA PERNI O ANEMOS ?
read-2nd s. the(neut.) GONE WITH THE WIND ?
15. Dhokimases $\left\{ \begin{array}{l} \text{*to(neut.) feta} \\ \text{ti(fem.) " } \end{array} \right\} ?$
tried-2nd s. $\left\{ \begin{array}{l} \text{*the(neut.) (cheese) feta(fem.)} \\ \text{the(fem.) " } \end{array} \right\} ?$

To sum up, cases like those exemplified by 11-12 may be considered as either a sort of 'ellipsis' of a particular or a more general word/expression, or as a nominalization process by which an item not 'inherently' a noun is assigned the category N. In the former case we have a complement

We propose the following structure for [+nom] complements

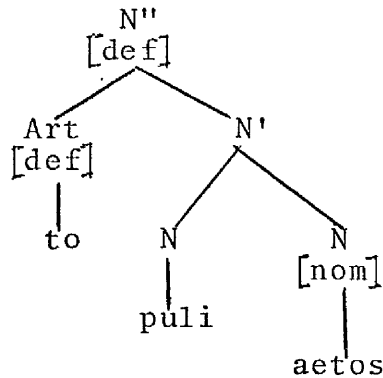

The complement node must be N rather than N'', for, as we said previously, it cannot expand freely. The complement here is just a 'bare' noun (in the case where the complement is a title with its own pre/post-head material, its inclusion in quotation marks shows that this material is not due to the expansion of the dominating node; we could perhaps write the complement node as

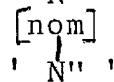

We must also notice the absence of the feature [+def] under the complement N node, which is necessary in appositional complements, when the head is also definite. As for the level of attachment of the complement, there is evidence suggesting it must be a complement of N. First it cannot pronominalize (**to puli aetos ke ekino vias* - the bird eagle and the one eagle-owl); second, it appears to constitute a unitary semantic entity with its head noun; notice that often head and complement belong to the same set (*puli-aetos*), or otherwise, the complement is a kind of exemplification of the head. Thus, the complement is tightly bound to its head (cf. Jack. 1977:58), therefore it cannot belong but to N and be

considered as a functional argument of the noun (ibid. p. 57) (cf. also p. 181).

2. Summary

In this chapter, we considered three types of complements of the noun phrase. In the first place an ambiguous appositive construction was presented, and support was provided for 2 structures corresponding to the two interpretations we claimed this can have, namely 'pseudopartitive' (amount) and consistive. For the first, we examined in some more detail measure or unit phrases, for the second we briefly considered ordinary consistive complements conveyed by an *apo*-prepositional phrase or a genitive (primarily indefinite). Then, the partitive construction was analysed; we pointed out the fact that no (structural) confusion exists between MG partitives and so-called pseudopartitives, although an occasional overlap between consistive complements (when definite) and partitive complements (by definition definite) raises some problems; but the difficulty may be overcome by the interaction of restrictive relative clauses, properly attached to the noun phrases involved in the partitive construction, with the subcategorization properties of the categories introducing the partitive (or consistive) complement. Finally, a complement of N marked as [+nom] was briefly considered. In the following chapter we shall present an analysis of Restrictive Relative clauses and of nominal ('Free') Relatives.

NOTES

1. Paraphrasing Allan (1977), some classifiers in some classifier languages are uniquely associated with particular nouns and can be said to have identical denotations with them. It is rather puzzling that unique classifiers should exist, because they reduplicate in full the information carried by the associated noun. Also, the relationship between classifiers and nouns is typically explicable but not always predictable without extensive knowledge of the relevant language. It is not unusual, however, for a noun class to include a number of members which seem to have been arbitrarily assigned to it, although a rational explanation might turn out to be available to the 'industrious scholar'.
2. Of course, the existence of seven categories of classification does not invalidate the claim that classifiers denote specific characteristic(s) of the noun they modify. Thus, it is said of unit counters in English that, like classifiers, they denote some characteristic possessed by the denotation of the noun with which they occur; this is so, independently again of the fact that such a counter can be used without a noun when its reference is either understood or unnecessary in the situation of utterance.
3. NPs like 31b' still sound peculiar, and the definite *apo* complement is usually replaced by a definite genitival NP, such as that of 32b'. I do not have an explanation for this alternation; however, one reason may be that the definite *apo*-phrase after the class of nouns that occur in 31b' and 32b' tends to be interpreted as a partitive complement, (see p.233 onwards).

4. There are two exceptions to this constraint on definiteness, where the definite article before the complement appears to be optional: a. when the head noun is a seminumeral - as it is called a 'substantival numeral' - like *ekatosti* (a hundred), *dhekarya* (about ten), *dhodhekadha* (a dozen) etc., which, when they function as specifiers in the pseudopartitive construction, are always preceded by an indefinite article. b. When a numeral or a quantificational adjective intervenes between the definite article and the head noun, e.g. *ta pola pyata (to) fai* (the many plates (the) food). I cannot account for this optionality. If the first article belonged to *fai*, that would argue against our assumption that measure phrases are under N'' as inherently indefinite and would make the above phrase exactly parallel to *to poli fai*. However, the article belongs clearly to the first noun and for this reason this must be the head of the whole phrase.

5. Thus, the following arguments are given by Stockwell, Schachter and Partee (1973), which show why in the derivation of the *two of the boys* the partitive analysis assumes a deletion of a noun after the quantifier, as in *two boys of the boys*.¹ In non-restrictive relatives, like *the boys, many of whom carried placards...*, *the boys* must be analysable as a NP, which is not possible if the determiner is *many of the*. 2. Phrases like *everyone of the boys*, *each (one) of the boys*, *any (one) of the boys* show traces of intermediate steps of the partitive derivation. The variation in deletability of *one* after quantifiers has to be marked on independent grounds, because of the pronominal use of quantifiers (cf. Jackendoff's substantivization). 3. Only four paintings of those which had been stolen were recovered. Only four \emptyset of the paintings which...

4. A slightly different construction lends more support to the partitive analysis: Only one trout of the fish we caught was large enough - Of the fish we caught only one trout was large enough (in this construction the first noun is retained if it differs formally from the second).

5. The three of the twenty boys who were in the room who wanted help screamed. At least one of the stacked relatives is associated with *three*.

6. Number agreement between quantifiers and restrictive relatives is automatically accounted for in the partitive analysis: *One of the boys who is in the room who want... One of the boys who is... who wants.

7. Number agreement for singular *one, each, every, (n)either of...* is handled much more naturally, since the head noun is singular.

8. I bought a dozen of the eggs, two of which were cracked. Non restrictives have two occurrences. This sentence is ambiguous, and since *I bought a dozen, two eggs of which were cracked is ungrammatical, dozen eggs of the eggs might be present at some earlier stage.

9. In the partitive analysis, the plural indefinite article *some* can automatically occur in the environment... *of the boys*. So, there is not need for another *some* to be postulated, as would otherwise be necessary.

10. The iterability of the quantifiers is accounted for, because, given the analysis Q N of NP, the last NP can itself be of the form Q N of NP: He ate some of each of the ten pies.

6. The subjacency condition holds that a cyclic rule cannot move a phrase from position Y to position X in the configuration. ...X...[α ...[β ...Y...]...]...X... where α and β are cyclic or, to use a more recent term, 'bounding' nodes - i.e. \bar{S} and NP (Chomsky 1977:73).

7. Instead of a definite *apo*-phrase, a definite genitive NP may appear after category d and f(ii). This is called Partitive Genitive. This genitive does not constitute a productive construction in MG - it never appears after quantificational adjectives, numerals, demonstratives or group nouns. Moreover, even after the items it subcategorizes, it constitutes more or less fossilized expressions which are used rather by self-consciously educated people. Furthermore, we shall see below that the genitive of the personal clitic can appear after certain numerals when preceded by the definite article, as well as after the universal quantifiers *oli* (which, as we said, cannot subcategorize a partitive *apo*-phrase), and *kathenas* (each, everyone).

8. However, it seems semantically odd for the *consis-*tive complement to contain a quantificational adjective, if the head is a collective (or mass) noun with an inherent meaning of quantification, though there is not any obvious way to prohibit such sequences syntactically. As the examples cited show, if a numeral appears in the complement no problem arises.

9. But cf. example 39 below, and note 10.

10. What is said here about number agreement concerns the noun of the complement when it is either a countable noun, hence in plural, or marked as [+MASS]. In the latter case it appears in the singular, consequently the head noun will also be in the singular. The interrelationship of these features (i.e. \pm count) with the number of the head is certainly related to the function of the partitive phrase (see p.212).

11. Of course, a restrictive relative can also be attached to the complement; although this does not improve the situation in 47(a'-c') (cf., for English, Jack. 1977:ch. 7.5), it is relevant in interpreting strings like 47(a-d) as containing a consistive complement, if such a relative is added, and also in making 47(a'-c') be interpreted as partitives, if the head noun contains a restrictive relative too.

12. In fact, 47a and c may be ambiguous between a partitive and a consistive reading. Both partitive and consistive *apo*-phrases are complements of N, therefore followed by restrictive relatives. Moreover, the subcategorization properties of the head noun allow for both types of complements. Thus, there is nothing to prohibit both readings here, although a consistive reading in 47b is rather excluded due to the subcategorization properties of the head noun, which is representative of the partitive category (f ii, see p.226).

13. I am not sure if *kathenas* is just an N' Specifier, for it can be used as a noun (presumably with an empty head), and be preceded by the definite article, e.g.:

*0 *kathenas anthropos*
kathenas anthropos
o *kathenas* ({^{apo}_{tus} } *aftus*)

Contrast this with strings with (*kanenas*) *kanis*

*0 *kanenas anthropos*
kanenas anthropos
*0 *kanenas* ({^{apo}_{tus} } *aftus*)

14. But this is not the case with the other 'universal quantifiers' *kathenas* and *kanenas*. I cannot explain this asymmetry. One reason, however, might be that *kathenas* and *kanenas* contain the morpheme for the numeral *one* (*enas*), and this, by nature, enables them to be followed by an *apo* (i.e. *partitive*) phrase.

15. Peculiarly, however, only numerals including five(5)-*pende*.

16. We should mention here that it is only the function of the clitic pronoun in strings like 60b-c that is characterized as partitive (genitive), since morphologically it is claimed by Tzartzanos to be an accusative. But notice that this can not be true, for examples like *ales tus* (other(fem.) them(clit.)), *to proto tus* (the first (neut.) them (clit.)), are given as an exemplification of this claim. However, the accusative of the feminine clitic (plural) is *tis*, not *tus*, and that of neuter is *ta* not *tus*, therefore, since the head noun and the noun of the partitive complement agree in gender (see p. 228) if the clitic were in the accusative it ought to be *ales tis* and *ala ta* - but they are not. *Tus* is, clearly, genitive, consequently, partitive genitive.

17. Sometimes such strings may be confused with compound nominals of the sort 'fighter-bomber' etc. (MG *polis-tikhi* cities-walls, *anthropi-terata* men-monsters, *sklavi-polites* slaves-citizens), with which we shall not deal. These are considered by N. Burton (1975) as semantic and syntactic constituents of another superordinate entity that is distinct from both of them. In other words, a new entity is synthesized out of these compound nominals. What is important is

that in the compound nominals *both* NPs are declined, unlike [+nom] complements, in parallel. In addition to that, it seems that there is a particular semantic relationship between the two members of a compound nominal, which may happen to exist in the case of *ghala-skoni* for example, but not in the case of **puli-aetos*, **paraghondas-anthropos* etc.

IV. RELATIVE CLAUSES

A. ADJECTIVAL RELATIVES

0. Introduction

Till very recently Relative Clauses were considered to be a unitary sentential category in Modern Greek, without any further distinction, apart from that between *genuine* RCs and 'mixed' (=adverbial) RCs of the type:

1. Tha prozlavi mia ghlosomathi ghramatea i opia
will engage a language-educated secretary the who
na tu krata tin aliloghrafia
to him keep the correspondence
He will engage a bilingual secretary to look
after the correspondence

It was in 1976 that the distinction between *restrictive* and *appositive* (called 'additional'/'additive') RCs was formally drawn in the College Syntax of MG. These two kinds together constitute the general class of so-called 'adjectival' (Relative) Clauses. Thus, in the following sentences the NP *topi* (places) is modified by a prenominal adjective in the first example, by a modifying prepositional phrase in the second, by an adjectival relative in the third (cf. II 3)

2. I *anidhri* topi ine aghoni
the waterless places are barren
Waterless places are barren
3. Topi *khoris nero* ine aghoni
places without water are barren

4. *Topi pu dhen ekhun nero ine aghoni*
places that not have water are barren
Places that do not have water are barren

Cf. also Lyons 1977, 2:761 "...just as an attributive like 'tall', denotes a property which supplies a value for x in referring expressions like 'the x man', so too do restrictive relative clauses (and they are traditionally classified as adjectival clauses)'".

Although the term 'Free Relative' is not mentioned in traditional grammars of Greek, adjectival RCs are distinguished from 'nominal' ('ουσιαστικές') RCs in terms of the different pronouns that introduce them, as well as of the different syntactic function they perform in a sentence. Therefore, nominal RCs have been established as a subcategory of 'nominal subordinate clauses', together with clauses introduced by the complementizers *oti/pos*, *na*, and indirect questions.

In this chapter I shall first point out the distinction between restrictive and appositive RCs. Then, I shall present a syntactic account of restrictives. In the light of, mainly the syntactic, differences between restrictives and appositives I shall assign a different structural position to each, taking into consideration the interaction of these two types of Relative Clauses.

In a separate section the distinction between adjectival and nominal (Free) relatives will be further justified and the internal structure of Free Relatives will be discussed.

1. Differences between restrictives and appositives

The basic difference between restrictives and appositives can be clearly seen by considering the

following examples:

5. O adherfoz mu, pu erghazete sti drapeza
the brother(of)-mine, who works in the bank,
ekhi mono
has-he only
ena mina adhia
one month (of)-leave
My brother who works at the bank gets a leave
for just one month
6. O Yanis, pu ine o kaliteroz mu filos, erkhete
the John, who is the best(of)-mine friend, comes
avrio aeroporikos apo to Ganadha
tomorrow by air from the Canada
Yanis, who is my best friend, is coming tomorrow
from Canada by plane
- 7.a. I kathiyites tu, pu piran meros stin ekdhromi, ...
the teachers(of)-his, who took place in the excursion..
The teachers of his, who participated in the excursion..
- 8.a. I aghrotēs tis periokhis, pu ta portokalia tus
the farmers(of)-the area that the oranges(of)-theirs
katastrafikan apo to bagheto...
were destroyed from the frost...
The farmers of the area, whose oranges were
destroyed by the frost...
b. I aghrotēs tis periokhis pu ta portokalia tus
katastrafikan apo to bagheto
The farmers of the area whose oranges were
destroyed by the frost...
9. ...vriskete sti broti dulapa, pu
...is found-3rd s. in-the first cupboard, that
ine sinithos klidhōmeni
is usually locked
It is in the first cupboard, which is usually locked

The difference is obvious: in 5 the speaker has only one brother and the information he wants to convey about him is that he gets leave of absence just for one month. The fact that his brother works in a bank is added as a further-but needless-detail. If, on the other hand, the speaker happened to have more than one brother, then the fact that this particular brother worked in a bank would no longer be redundant, because this would distinguish this brother from the rest (who, obviously, do not work in a bank). Thus, the RC in this case does not carry some additional detail about a certain person, who is already uniquely identified - at least in the particular context - but, on the contrary, it is crucial for the identification and establishment of the referent. The same remark obtains of examples 7 and 8. In the a. sentences the referent is already identified and the relative clause is a kind of 'parenthetical comment' or 'afterthought', whereas in the b. examples it forms an indispensable part of the specification of the referent; it contributes to picking out "the actual referent from the class of potential referents" (Lyons 1977, 1:180). In sentence 6 the RC is necessarily appositive only, since the identity of the referent is inherently determined (notice the obligatory presence of the article in front of a proper name in MG). In a similar way, in 9 the RC cannot be restrictive either, because the noun phrase it adds information about is again already identified. The fact that the cupboard is locked is accidental and has nothing to do with its identification.

1.1 Appositives belong to a separate intonation group

The above remarks are reflected in the fact that appositives, or non-restrictives, belong to a separate

intonation group - i.e. are "at least potentially distinguishable by rhythm and intonation in the spoken language" (Lyons 1977; 2:760), and when written they are set off by commas or a hyphen. In effect, they have "a different illocutionary force associated with them from that which is associated with the rest of the text-sentence within which they occur. In this respect they are parenthetically inserted independent clauses. For example the sentence *That man, who broke the bank at Monte Carlo, is a mathematician* can have the same range of interpretation as *that man - he broke the bank at Monte Carlo - is a mathematician*" (ibid.) .

1.2 Formal correlates of the differences between restrictives and appositives

One might wonder whether the above - semantic - distinction between restrictives and appositives has some formal expression. The following examples show that there are such formal correlates:

- 10.a. To roloi pu aghorase stin Elvetia,
the watch that bought-3rd s. in the Switzerland,
pu ine Omega...
that is Omega...
The watch he bought in Switzerland, which
is Omega...
- b.*To roloi, pu ine Omega, pu aghorase
the watch, that is..., that bought-3rd s.
stin Elvetia...
in the Switzerland...

10.a-b show that the appositive RC strictly follows the

restrictive. This order cannot be reversed, and, as we shall see later, it follows automatically from our proposals about levels of attachment of RCs within NP. Moreover, this strict order clearly shows that the NP must be 'defined' before one can add 'extra information' about it.

Restrictive relatives can only have nominal heads, whereas appositives can also follow sentences:

- 11.a. Dhyavazi arkheus singhrafis sto prototipo, pu
reads-3rd s. ancient authors in the original, that
to vrisko thavmasio ya mikro pedhi
it find-I excellent for little child
He reads classical authors in the original, which
I find excellent for a young child
- b. Pire tis perisoteris psifus, pu kaniz dhen do
took-3rd s. the most votes, that nobody not it
perimene
waited-3rd s.
He got the most of the votes, which nobody
expected

The relative clause here can only be understood as belonging to the whole preceding sentence; this is formally shown by the resumptive pronoun - *to* (it) — which in these cases is always in the neuter singular, or, equally, by the standard expression *praghma pu* (=thing that), the noun of which (*praghma*) is of neuter gender, too. Appositives can also appear after PPs:

12. Ya na to sizitisume afto tha prepi
for to it discuss-1st pl. this will must
na minume
to stay-1st pl.
edho apo tora os ta ximeromata, pu ine peri-
here from now till the dawn, that is more
soteros khronos apo oso fandazese
time than what imagine-2nd s.
In order to discuss this, we shall have to
stay here from now till dawn, which is longer
than you think

Again the predicate *perisoteros khronos* (more time) shows that the RC can only belong to the (temporal) prepositional phrase. And after adjective phrases¹:

13. O pateras su ine poli kakhicoptos, pu esi
the father(of)-yours is very suspicious, that you
dhen ise
not are

Your father is very suspicious, which you are not

At this point it is worth mentioning that although appositives in MG, unlike in English, are introduced by either the complementizer *pu* or the wh-pronoun *o opios*, appositives that follow PPs and APs are only introduced by *pu*, and appositives that follow sentences are most commonly introduced by *pu* and very rarely by *to opio* (which, if used, is always in the neuter singular, matching the equivalent noun *to praghma*, cf. above).

As will be discussed in detail later, in restrictive relatives we never get a personal pronoun - other than a clitic in certain cases. Nevertheless in appositives only we can have the emphatic sequence *ke aftos*

('and he/this (one)') (similarly in adverbial relatives
ke eki/edho ('and here/there')):

14.a. ...skeptotan poz na kripsi ton erasti, pu
...thought-3rd s. how to hide-3rd s. the lover, that
ky aftos arkhise na tremi apo to fovo tu
and this one began to tremble from the fear(of)his

b.*...skeptotan pos na kripsi ton erasti pu
...thought-3rd s. how to hide-3rd s. the lover that
ky aftos arkhise na tremi apo to fovo tu
and this began to tremble from the fear(of)-his
She was thinking how to hide her lover, who
started to tremble by fear, too

15.a. Dyavasa to telefteo vivlio tu..., pu ky afto
read-I the last book(of)..., that and this
to ikhe apaghorepsi i dhiktatoria
it had forbidden the dictatorship

b* Dyavasa to telefteo vivlio tu... pu ky afto
to ikhe apaghorepsi i dhiktatoria
I read the last book of..., which was also
forbidden by the dictatorship

The b sentences above are quite uninterpretable in the form in which they appear, i.e. without a comma in front of the (appositive) relative. The only way in which they can be understood is as appositives. Anticipating a little the discussion which will follow on the structure of relatives, this presence of the full pronoun in the above examples makes it absolutely clear that these are sentences without 'gaps'.

As has been pointed out (Jack. 1977), restrictives can be focused (and negated), whereas appositives cannot (cf. III 0) e.g.:

16.a. Dhe milisame me ton anthropo pu pandreftike
not spoke-we with the man that was married
ti MARIA (ala m'afton pu pandreftike tin Eleni)
the MARY (but with that that was married the Helen)
We didn't speak to the man that married MARY, but..

b* Dhe milisame me ton anthropo, pu pandreftike
not spoke-we with the man, that was married
ti MARIA
the MARY

*We didn't speak to the man, who married MARY

It has also been said for English that while restrictives can be stacked within an NP², appositives can only be conjoined. The same is not true of MG, however. Appositives can be stacked. Thus, two or more appositives may appear together without a conjunction, this being, presumably, simply an alternative to coordination with *ke* ('and'), e.g.:

17. O kathigitiz mu ton aglikon, pu ton
the teacher(of)-mine(of)-the English, that him
ghnorises khthes,
met-you yesterday,
pu su ferthike toso evyenika,...
that (to)-you behaved-3rd s. so kindly...
*My teacher of English, whom you met yesterday,
who was so nice to you...

The same does not happen with restrictives. Here the conjunction *ke* is indispensable:

18. O kathigitiz mu pu ghnorises khthes
the teacher(of)-mine that met-2nd s. yesterday
ke pu su
and that to-you
milise toso therma³...
spoke-3rd s. so warmly...
My teacher you met yesterday and who spoke
to you so warmly

1.2.1 The object clitic pronoun in appositives

Finally, there is a major difference between restrictives and appositives that shows up clearly in RCs with a direct object (DO) dependency. The following examples illustrate this:

- 19.a. Ekhasse ton aftosevazmo pu ikhe
lost-3rd s. the self-respect that had-3rd s.
b* Ekhasse ton aftosevazmo pu *ton* ikhe
lost-3rd s. the self-respect that it had-3rd s.
He lost the self-respect he had.
- 20.a. Emine ekplikti me tis fandastikes istories
was astonished-3rd s. with the imaginary stories
pu akuse
that heard-3rd s.
b* Emine ekplikti me tis fantastikes istories
pu *tis* akuse
She was astonished at the imaginary stories
she was told
- 21.a. ...sto proto *taxi* pu tha vris brosta su..
in-the first taxi that will find-2nd s. in front
(of)-you

- b.* ...sto proto taxi pu tha to vris brosta su .
...in the first taxi you will meet
- 22.a. Ta tria orfana pu ghnorise to panelinio
the three orphans that knew the whole-Greece
- b.* Ta tria orfana pu ta ghnorise to panelinio
The three orphans that became known to whole Greece
- 23.a. To roloi pu ekhase
the watch that lost-3rd s.
- b.* To roloi pu to ekhase
The watch he lost
- 24.a. Ta nomizmata pu ekhi sti siloyi tu
the coins that has-3rd s. in-the collection
(of)-his
- b.* Ta nomizmata pu ta ekhi sti siloyi tu
The coins he has in his collection
25. Akuse me khara to meghalo neo, pu toso kero
heard-3rd s. with joy the great news, that
to lakhtaruse
so(much) time it longed-3rd s.
He heard with delight the great news, which
he had longed for so long
26. To roloi tu, pu to aghorase stin Elvetia,
the watch(of)-his, that it bought-3rd s. in
tu kostise elakhista
the Switzerland,(to)-him costed very little
His watch, which he had bought in Switzerland,
costed him very little

27. Efere mesa ta fayita pu ta ikhe kripsi
brought-3rd s. in the foods that them had hidden
i ipiretria
the servant
He brought in the food, which the servant had hidden
28. Kharike me to akuzma tis fonis tu andra tis,
was pleased-3rd s. with the hearing(of)-the voice
(of)-the husband (of)-hers
pu dhen don perimene toso noris
that not him expected-3rd s. so early
She was pleased at(hearing) her husband's voice, whom
she didn't expect so early
29. I kremes, pu tis khrisimopiun apoklistika i yinekes
the creams that them use exclusively the women
Creams, used exclusively by women...

In the first group of the above examples (19-24), the relative clause which can only be interpreted as restrictive does not allow the presence of the object clitic pronoun; but in the second group (25-29) the relative clause, which is interpreted as appositive only, does have the clitic pronoun. The theoretical consequences of this differentiation and the problems it entails for our syntactic account of RCs will be discussed in detail in the next section. For the time being it will suffice to answer the following question: why can the RC in the examples 19-24 not be interpreted as appositive? I.e. why are 19-24(b) ungrammatical? Does this mean that not every NP can be modified by both a restrictive and an appositive NP? To answer to this question we must recall the different roles appositives and restrictives perform in a sentence (cf. p. 263). Appositives provide additional information about an already (uniquely) identified - or identifiable-NP, whereas the function of restrictives "is to specify one

particular referent member of a class of individuals" (Lyons 1977, 1:181). Comparing sentences 19-24 with 25-29, we see that the head NP in the second group is already uniquely identified independently of the contribution of the RC⁴. The fact that it is so identified follows from a variety of contextual and pragmatic considerations. By contrast, the head NPs in 19a-24a are not already identified, despite the fact that they are definite. Thus, if the relative clause is omitted we are left wondering 'pyon aftosevazmo ?' ('which self-respect?'), 'pyo roloi ?' ('which watch ?'), 'pya tria orphana ?' ('which three orphans ?') etc. It is the RC that provides the answer in each case, consequently 19b-24b are necessarily bad, since the RC here is appositive, even though when written it is not separated by commas from the head NP⁵, thus providing no precise definition or restriction on the head NP, whereas sentences 24(a)-29(a) are definitely good⁶.

1.2.2 Bache @ Jakobsen's distinction between restrictives/non-restrictives

At this point it is worth mentioning, I think, Bache @ Jakobsen's article 'On the distinction between Restrictive and non-Restrictive Relative Clauses in Modern English' in which they establish a 'communicative criterion' for an intuitive classification of certain sentences as restrictives or appositives *despite their formal characteristics*. Here, according to this criterion, a definition of restrictives (see p.279 below) and appositives is formulated which accommodates both definite and indefinite NPs, including indefinite specific NPs. It also applies to both singular and plural expressions - and

uncountable expressions. Moreover, the definition of restrictiveness as elaborated in this article (see below) makes explicit in what sense a modifier can be said to restrict. With respect to the function of a RC in an NP, it is stressed that the difference between an appositive (*The soldiers, who ran forward,...*) and a restrictive (*The soldiers who ran forward....*) is not primarily one of restrictiveness but one of 'world states'. More accurately, when describing a situation of soldiers running forward, an addresser never has a choice between an appositive and a restrictive, as they are given above (cf. 19-24(a-b)) - since the distribution of these sentences is a question of different situations. Rather, he must construct a linguistic expression which matches the situation he wants to describe. Thus, to see the different function of an appositive and a restrictive we should compare sets of constructions where both alternatives are possible in the same context. Thus, the difference is that the relevant sentences involve different ways of presenting information in terms of *information units*: either (in restrictives) we have one and the same tone group, therefore one information unit, or (in appositives) the information contained in the RC constitutes an independent tone group (cf. Lyons 1977, 2:760), therefore an independent unit of information. But the question that arises is exactly this: on what basis does an addresser choose between presenting the information conveyed by a complex NP as belonging to one or two information units? (cf. B. & J. 1980). To come to our examples, the answer to this question will explain more clearly why sentences 19b-24b are bad - i.e. why an appositive relative after those NPs is inappropriate - and why 25-29 are good i.e. why the NPs here, if they are to be accompanied by a RC, require from this to be

appositive. We shall also be able to explain why in a majority of sentences a relative clause of a complex NP can be interpreted in both ways - as restrictive and as appositive- especially in indefinite NPs. To this effect we shall use one of Bache and Jakobsen's examples. Given a set of symbols like:

U = everything that can be referred to by
using the particular head NP (e.g.
'certain gentlemen')

\bar{U} = everything not belonging to U

R = members of U for whom the predication
'who...' holds

\bar{R} = members of U for whom this predication
does not hold

the difference between a pair of sentences like

a. Certain gentlemen who are mine...

and

b. Certain gentlemen, who are mine

is explained as follows: in restrictive relatives, x (where by $x \in R$ we mean that x stands for the actualized referents of an NP containing a RC) is actualized as a member of R establishing an explicit contrast between R and \bar{R} . This is accomplished if we make the predication of the RC (f(x)) an inherent part of the information unit to which the head NP belongs. In effect, this means that the contrast between R and \bar{R} rests on the distinction between members of U for which the predication of the RC holds and members of U for which this does not hold. On the other hand, in non-restrictives the addresser actualizes x as a member of R "stepwise by first establishing

an explicit contrast between U and \bar{U} , and then providing f(x) in a separate information unit... The predication f(x), when conveyed in a separate information unit, involves a contrast with other possible predications of x, but this contrast does not overrule the contrast between U and \bar{U} established by the head NP" (B.@ J, 1980:257). This difference can be schematically represented as:

Certain gentlemen who are mine...

R vs \bar{R}

Certain gentlemen, who are mine

U vs \bar{U}

f(x)

This basic distinction between the two kinds of relative clauses in terms of numbers of 'information units' is reflected, with respect to Modern Greek, in the difference between these two sorts of relatives concerning the presence of the clitic resumptive pronoun - as we saw in 19-29. Thus, since in restrictives there is just one information unit, the clitic pronoun within the RRC is redundant, whereas in non-restrictives, where we deal with two information units, it is needed in the second unit to remind that about which the predication is made. Furthermore, this theory accounts for another interesting fact, that of a 'double' interpretation of a relative clause modifying an indefinite specific NP. It is claimed that it is characteristic of indefinite specific NPs that the addresser has a choice between presenting the information contained in the NPre1 (the head NP plus a following RC) as one or two information units. This is a meaningful choice, but the difference in meaning between the

restrictive and the non-restrictive is such as to make both possible in the same contexts. The choice here is '*presentation-oriented*' (B. @ J. 1980). This can explain why in RCs that follow an indefinite NP, the clitic pronoun is sometimes present and sometimes it is not there at all, but in both cases the result is grammatical, e.g.:

30.a. Enas anthropos pu dhen ikha xanadhi
a/one man that not had-I seen again
A man I hadn't seen before

b. Enas anthropos, pu dhen don ikha xanadhi
a/one man, that not him had-I seen again

In 30a the relative clause is restrictive and the clitic does not show up; in 30b it is appositive and the clitic can appear (optionally at least; it could be interpreted as appositive, even if it was not present). It is also the case that consideration of presentation may sometimes lead to a preference for one possibility rather than the other. Thus, in a sentence like

31. Ena dhistikhima pu oli mafeftikan na dhun...
An accident that everyone gathered to see...

the RC is more natural to be interpreted as restrictive - i.e. to make the whole NP rel (part of) one and the same information unit; the reason is that the information contained in the head NP is not "relevant in itself but only in conjunction with the information contained in the RC" (B. @ J. 1980:259); whereas in a sentence like 32:

32. Ena pelorio roloi pu i mathites to lene
a huge watch that the pupils it call-3rd pl.
'thorikto'...
battleship...
A huge watch, which the pupils call 'battleship'...

the relative clause is more likely to be read as appositive, since the head NP is already modified by a *restrictive* modifier (the adjective *pelorio* (=huge), thus establishing direct contrasts to various other kinds of - here - watches (cf. B. @ J 1980:259). A RRC may become almost obligatory if the NP it modifies is or is similar to a grammatical dummy, its "raison d'être being to make it grammatically possible to convey the information contained in the RC (cf. *a manner which brooked no enquiry from anyone, something which was at least true*)" (ibid. p.260). Thus, the 'lighter' the modified head NP is semantically, the more likely the addresser is to choose a restrictive relative. With contrast to this, there is not a free choice either in sentences like

- 33.a. He has four sons who...
b. He has four sons, who...

where the implications are different in the restrictive (33a) and the appositive (33b) relative (since the difference is a question of the extent of the scope of the quantifier), or in definite specific NPs, where textual relations are crucially involved in the distinction between restrictive and appositive RCs. Such a relation concerns the condition for the use of the definite article. It is claimed that there is no pragmatic choice here, because the status of the RC is a reflection of its role in establishing the familiarity which warrants

the addresser's use of the definite article. It is the presence of the relative clause which enables the addressee to identify which watch, book etc. the addresser is talking about. With non-restrictives the information of the RC is not part of the familiarity conditioning of the definite article. This means, in terms of the number of information units, that "what is relevant is the extent to which linguistic material following the definite article can be part of the familiarity presupposed by its use". (B @ J. 1980:262). Thus, for linguistic material following a definite article to contribute to establishing the familiarity required, it must occur in the same information unit as the definite article. We expect then that the object clitic pronoun will not appear in object relatives, which are in this case interpreted as restrictives (cf. examples 19-24a); information which makes no such contribution typically occurs in a separate information unit; it is in this case that the object pronoun appears in object RCs, which are interpreted as appositives, cf.:

34. I friki pu dhen di dhikhni i tenia
the horror that not it shows the film
Horror which the film does not show

Here the relative clause *pu.....tenia* does not form part of the familiarity conditioning of the definite article (cf. p.263). This distinction between restrictives and appositives is '*identification-oriented*' (B.@ J. 1980:262). We thus have seen that presentation-orientation and identification-orientation are responsible for the possibility of a RC being interpreted as both appositive and restrictive in indefinite and definite specific NPs. Exceptions to the presentation-oriented

characterization of the choice between restrictive/non-restrictive relatives in indefinite NPs, which force the relative clause to be interpreted as restrictive, bring forth the question in what sense a restrictive relative is said to restrict. It restricts in the sense that by belonging to the same information unit as the head NP "it contributes to establishing a contrast between what one is talking about and what he is not talking about. A non-restrictive by being singled out, predicates something about that which is being talked about, rather than contributing to establishing *what* is being talked about" (ibid. p.266). Along these lines we can say of examples 19b-24b that they are bad because the relative clause being appositive and, thus, not forming part of the familiarity conditioning of the use of the definite article, does not contribute to the identification of which X the addresser talks about, therefore the use of the definite article is 'faulty' and unjustified. Examples 25-29 are okay, because the familiarity of the use of the definite articles does not depend upon the RC following it, but is established on other grounds; therefore the RC is allowed to belong to an independent information unit and it is justified as appositive - as the occurrence of the clitic resumptive pronoun shows.

1.2.2.1 Summary

To summarize what our examples (19-29) and Bache-Jakobsen's theory show we can generalize as follows. In the light of the facts concerning relative clauses with a direct object dependency (see 2.2 and 3.3), it becomes clear that the clitic direct object pronoun is excluded from restrictive relatives. Occurrences of

this clitic in relatives suggest that the latter are appositives (but cf. also note 5). Accordingly, object relative clauses which must be interpreted as restrictives on independent grounds, are ungrammatical if the clitic object is inserted. Similarly, relative clauses obligatorily read as appositives can optionally have the object clitic. But there are cases where a relative clause may be interpreted in either way. It is in such cases where a clitic may or may not occur without destroying the grammaticality of the sentence. But if it occurs we have to interpret the RC as appositive, if not as restrictive. Bache and Jakobsen's theory formalizes nicely these facts, as well as our intuition about them, in terms of pieces of information units.

1.2.3 A further distinction between restrictives and appositives

Still on the same grounds, there are some more points which further show the distinction between restrictive and appositive relatives. We said with respect to examples 19b-24b and 25-29, that the RCs contained in them are appositives. In 19b-24b an appositive relative *is excluded* (i.e. inappropriate) - thus the examples in question are bad - whereas in 25-29 it is justified. We explained this differentiation in the two preceding paragraphs. We also claimed (p. 279) that the restrictive relative of sentences 19a-24a does not allow for the object clitic pronoun, and that this is only allowed in appositive relatives (19b-24b and 25-29). This correlation of non-restrictives and the presence of a clitic in direct object relatives is further seen in cases where a distinction is being made between two persons with the same name. Then the proper name will be followed by a

clause that is clearly *restrictive* in character, since it identifies the individual in question (cf. *pyos Yanis?* 'which John?') (cf. p.272):

35. O Yanis pu (*ton) ghnorises khthes spiti mu
the John that (*him) met-you yesterday (at)
house (of)-mine
'The' John you met at my house yesterday

(In this use, proper names can also be preceded by the indefinite article, requiring again a restrictive modifier to 'support' it (see II 3), cf. *mnya Athina pu maz misi* ('an Athens that hates us'), *enas Yanis aghnoristos* ('a John unrecognizable'). Here, just as in 19b-24b the clitic pronoun cannot appear in the RC which in both cases is definitely restrictive.

Personal pronouns are considered as one of the three main kinds of singular referring expressions (the other two being definite NPs and proper names) (cf. Lyons 1977, 1). It is intuitively clear that the grammatical category of person is directly related to the notion of participant-roles (the speaker representing the 'first' person, the hearer the 'second' - since "the canonical situation - of - utterance is egocentric, in the sense that the speaker casts himself in the role of *ego* and relates everything to his viewpoint" (Lyons 1977, 2:638)). Therefore, there is not any need for further justification, since the referent of the personal pronouns is inherently identified. Consequently, we expect that the RC that refers to them be appositive, and in fact it is so, as the obligatory presence of clitics, at least in examples like 36-37, shows:

36. Emena pu me vlepīs ime...
 {*∅}

me that me look-you I am...
 {*∅}

I, you are looking at...

37. Esi, pu dhe se theoro,...
 {*∅}

you, that not you regard-I...
 {*∅ }

You, whom I don't regard as a...

(However, counterevidence is provided by examples like *ti bela vrika me sena pu aghapisa* - what trouble found-I with you that loved-I - where we see that no clitic appears in the RC, which, in combination with the fact that no pause precedes the RC, suggests that the latter is rather interpretable as restrictive. I have no explanation for this). In roughly the same connection we notice that there are certain pronouns which do not tolerate appositive relatives:

38.a. Aftos pu_{ ∅ } sinandisa khthes
 *ton

that that ∅ met-I yesterday
 {*him}

The one I met yesterday...

b. To mono pu ∅ xero ine...
 {*to}

the only that ∅ know-I is...
 {*it}

The only thing I know is...

To 38a-b we can contrast 38c:

- c. *Aftos*, pu (ton) proighaghan se dhiefthindi...
this (man), that (him) promoted-3rd pl. to
director...

This man, who they promoted to director...

Why, then, in 38a is the clitic not allowed in the RC, whereas in 38c it may appear? If *aftos* in 38a is the 3rd person personal pronoun, in parallel to those in 36-37, then there is no straightforward way to account for the fact that in a RC after the 1st and the 2nd personal pronoun the clitic is required, being excluded from the RC modifying the 3rd person pronoun. As a solution to this contradiction I propose that the *aftos* in 38c be a personal pronoun, parallel to *esi/egho*, whereas the same word in 38a be what is called definite (or 'repetitive') pronoun, to use the terminology of traditional Grammars of MG. The referent of *aftos* of 38c is inherently identifiable, as that of the pronouns in 36-37 is. But the referent of *aftos* in 38a is identifiable only through the restrictive RC that follows it. In other words by using the pronoun *aftos* in 38c, the speaker is pointing out some particular person whom the hearer can actually see, therefore the referent is inherently identifiable and the RC does not need to be restrictive; in fact, it is strongly marked as appositive - by a clear comma intonation. *Aftos* here is heavily stressed⁷ as the underline shows; and I assume that it is, as a personal pronoun, inherently deictic, whereas *aftos* in 38a is the so-called 'definite' pronoun. The gloss and the translation show the English equivalents. I further assume that *aftos* that is called 'demonstrative' pronoun is the *aftos* which - much like an adjective - appears as a complement of N' in definite NPs, or in front of the whole definite NP (cf. p.179).

1.2.4 A difference in relativizeability between English and Modern Greek

It has been said (Carlson 1977) that a difference between English restrictives and appositives lies in the fact that appositives relativize all the positions (e.g. as they appear on the Accessibility Hierarchy of K. @ C. (1977)), whereas restrictives do not; cf.:

39.a. The men, all of whom were...

b.* The me n all of whom were...

However, the same is not true of MG. All positions seem to relativize. It is interesting - as we shall attest in the following paragraphs - that the clitic pronoun introduced by the slash elimination metarule II permits dependencies into positions in *pu* - relatives that could not otherwise be relativized. We shall see that this constitutes a major difference between *wh*- and non *wh*- relative clauses.

2. The internal structure of R Relatives in MG

2.1 Sentential categories of MG

Following Gazdar (1981), I am assuming that R(ela-
tive) is a sentential category representing a potential
constituent of every noun phrase. The sentential catego-
ry R exists in parallel with the categories V" (sentence)
and Q (constituent questions). The features by which the-
se categories are distinguished are $\pm C$ (omplement), $\pm R$ (ela-
tive, $\pm Q$ (interrogative). The combination of these featu-
res yields the following categories in MG:

1. V"(S) = [+V, -N, -Q, -R, -C]"
2. V"(\bar{S}) = [+V, -N, -Q, -R[+C[{oti, pos, pu}]]]"
[+C]
3. V"(root yes-no Q) = [+V, -N, +Q, -R-C]"
[+Q]
4. V"(embedded yes-no Q) = [+V, -N, +Q, -R[+C[an]]]"
[+an]
5. Q(root or embedded constituent Q) = [+V, -N[+Q[+wh]], -R, -C]"
6. R(restrictive non-wh relatives) = [+V, -N, -Q, [+R[-wh]], -C]"
[-wh]
7. R(" wh-relatives) = [+V, -N, -Q[+R[+wh] [$\pm FR$]], -C]"
[+wh]
8. V"(appositives with pu) = [+V, -N, -Q, +R[+C[pu]]]"
[+R]
[+pu]
9. V"(wh-appositives) = [+V, -N, -Q[+R[+wh]], -C]"
[+R]
[-pu]

Although we shall not discuss this system in detail, at
least some remarks are in order here. The feature [+wh]
indicates first *pyos*, *pote*, *yiati* etc. in Q, second
o opios etc. in R⁸ if the latter is marked as [-FR],

otherwise the relevant wh-forms if R is [+FR] - i.e. a 'free' relative; finally [-wh] indicates *pu* in R. With respect to 5, root and embedded constituent questions are treated together under Q since clearly some embedded Q are just like root Q; cf.:

40. (Anarotyeme) *pyos irthe* (?)
(I am wondering) who came (?)

With regard to 4, embedded yes-no questions are equated with V'' - instead of being \bar{Q} as in English. Thus, embedded questions are V''[an] (parallel to V''[pos], V''[oti], V''[pu]) and are subcategorized by verbs like *roto* (ask), *anarotyeme* (wonder) etc. Concerning 8 and 9, it seems that there is no need to distinguish formally appositives from sentences (i.e. V''), since the former do not contain gaps, as restrictive relatives do. Thus, R is kept only for relative clauses (restrictive) with a gap. The features [+Q], [+R], [+C] may have 'values' - be either complementizers or wh-pronouns (at least Q and R). Finally, R, as already said, and Q involve 'gaps' - all the other V'' categories do not (i.e. syntactically they share the same structure). In general, the following tree-schemata exhibit that:

- a) V'' where X is a specific complementizer

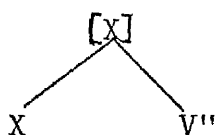

- b)
-
- A tree diagram showing a root node Q branching into two children: X on the left and V''/X on the right.

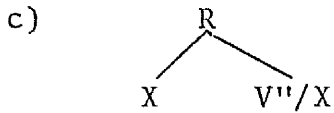

in b) and c) X is a *wh*-phrase or word, or, in the case of R, *pu* (see the relevant sections that follow). The 'slash value' of V'' follows from the category of the preceding X where this is a *wh*-phrase, otherwise (i.e. in R with *pu*) it has to be specified.

2.1.1 There are two types of RCs in MG

As shown in 6 and 7 above (p.285), Greek relative clauses fall into two major types as far as the morpheme that introduces them is concerned: one of them is introduced by the *wh* relative pronoun *o opios* (fem. *i opia*, neut. *to opio*) - always accompanied by the definite article (masc. *o*, fem. *i*, neut. *to*) - corresponding to the English *who/which*; the other is introduced by the non-*wh* complementizer *pu* - roughly corresponding to the English *that*. Either a *wh*-pronoun or *pu* must appear, i.e. we never get sequences like the English *The man I met* in MG.

We shall first examine *wh*-relatives, since their syntax is more straightforward (corresponding in general to English *wh*-relatives); then, we shall deal with the more problematic *pu*-relatives. In each type I am going to consider relativization first with respect to object dependencies, then with respect to subject dependencies, PP dependencies (where PP is either adverbial or a restrictive modifier), and possessive genitive dependencies. These positions are those participating in the Accessibility Hierarchy as established by Keenan and Comrie (1977); we shall have the chance to discuss their points in more detail later.

2.2 WH Relatives with object dependencies

Such relatives are illustrated in the following examples:

41. O anthropos ton opio sinandisa to proi
 the man the whom met-I the morning
 The man I met in the morning
42. I tenia tin opia parakoluthisa itan orea
 the film which attended-I was nice
 The film I saw was nice

In these examples, the relative clause consists of a pronominal NP which is followed by a sentence with a corresponding NP 'hole' in it - the pronominal NP and the matching 'hole' represent the 'displaced' object of the verb of the RC, and the hole, the position where such an object would ordinarily occur. This may be accounted for by the rule:

$$43. \quad \begin{array}{c} R \\ [+wh] \end{array} \begin{array}{c} [N'' \\ +wh \\ +pro \\ +acc] \end{array} \quad V'' / \begin{array}{c} N'' \\ [+acc.] \end{array}$$

where $N'' [+R +wh +pro] \rightarrow o \text{ opios}$

The slash category V''/N'' predicts - correctly - the non-occurrence of any lexical material in the 'gap'; therefore bad sentences like the following are blocked:

44. *O anthropos ton opio $\left\{ \begin{array}{l} \text{afto} \\ \text{ton}^9 \end{array} \right\}$ sinandisa to proi...
 the man the whom $\left\{ \begin{array}{l} \text{him} \\ \text{him}(\text{clitic}) \end{array} \right\}$ met-I the morning...

45. *0 anthropos ton opio sinandisa to batera mu...
the man the whom met-I the father (of)-mine...

2.3 WH Relatives with subject dependencies

According to what was said about subject dependencies in (English and) MG in the Introduction, it is worth repeating here that there is no problem in accounting for them. We need only have in mind that subject dependencies are exclusively into subject positions in 'flat' (VP-less) sentences, which exist in parallel with NP+VP ones. This, together with the condition on metarules that they apply only to lexical(ID)rules, enables us to write rules for RCs with a subject dependency that are not basically different from those accounting for RCs with an object dependency. The following examples contain relative clauses with a subject dependency:

46. 0 anthropos o opios me voithise...
the man the who me helped...
The man who helped me...
47. I fili su i opia irthe khthes...
the friend (of)-yours the who came yesterday...
The friend of yours that came yesterday...

As will be further justified below, it seems that RCs with subject dependencies are of the type V"/N", just like RCs with other dependencies (cf. also p.304). Accordingly, the rule expanding R in the case of matrix subject WH relatives will not differ from the one expanding R in the case of object relatives, except in choice of case on N":

48.
$$\begin{array}{c} R \\ [+wh] \end{array} \begin{array}{c} N'' \\ [+wh] \\ [+pro] \\ [+nom] \end{array} \quad \begin{array}{c} V''/N'' \\ [+nom] \end{array}$$

In 48 the case of both occurrences of N'' is the nominative. Case agreement is accounted for by the HFC (see p. 21).

The structure of sentence 46 (and 47) is represented in the following tree:

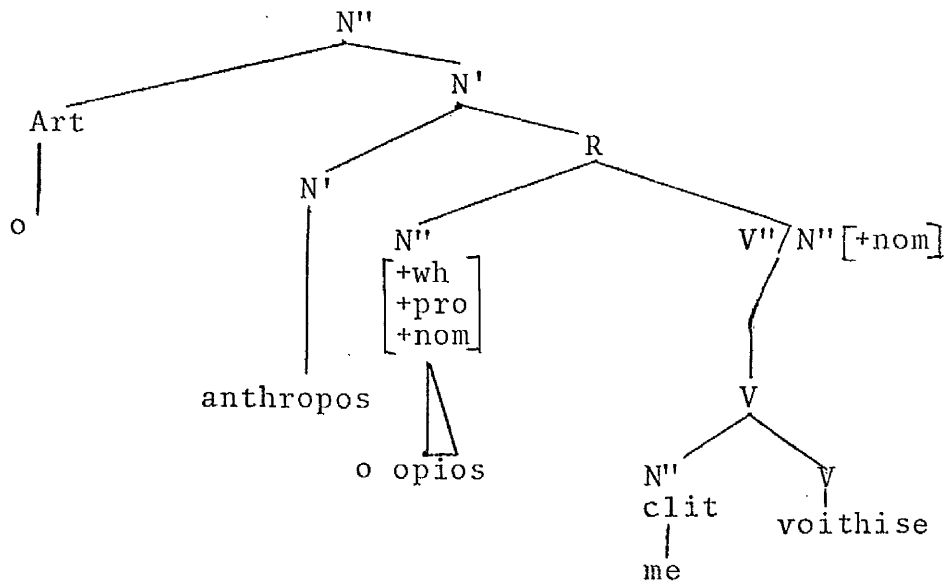

2.4 WH Relatives with a PP dependency

Such relatives are also simple and similar to corresponding English ones. They are shown in the following examples:

49. O kathiyitis ston opio edhosa to vivlio mu...
 the professor to-the whom gave-I the book(of)-mine
 The professor to whom I gave my book...
50. I kopela me tin opia meno...
 the girl with the whom live-I...
 The girl with whom I live...

51. I poli apo tin opia kataghome...
the city from the which come-I...
The city from which I come...

In 49 the PP *ston opio* (*to whom*) represents the indirect object (a dative) of the verb *edhosa* (aorist, 'to give'). However, syntactically it is not distinct from the PPs in 50-51, where these are 'genuine' PPs - a restrictive modifier in 50 and 51 - since subcategorized PPs (e.g. that of 49) are marked with the name of the required preposition, this being the formal marking of 'case marking'. (Alternatively, we can classify adverbial or modifying PPs as [+major], and 'case marking' ones as [-major] - then either type will be allowed to bear a 'name', if this is necessary (cf. also p. 349-350)).

The difference between Greek relatives with a PP dependency and the corresponding English relatives is that the former exhibit *obligatory* pied-piping, and that preposition stranding is not tolerated:

52. *I poli tin opia kataghome apo...
the city the which come-I from
The city I come from

53. *I kopela tin opia meno me...
the girl the whom live-I with...
The girl I live with

I propose the following rule for the generation of PP dependency RCs :

54. R $\begin{bmatrix} P'' \\ [+wh] \end{bmatrix} \begin{bmatrix} V''/P'' \\ [+wh] \\ [+pro] \end{bmatrix}$, where $P'' [+R +wh +pro] \rightarrow P + N''$

[+R +wh +pro +accus.] (= *ton opio*)

[+wh +pro] are foot features coming from the NP that is the object of the PP.

Examples like 52 and 53 can be generally avoided by a reference to the categories that are allowed on the projection path - i.e. PP is excluded from these, therefore the category *P"/N" never appears -; in other words, NP dependencies into PP in *wh*-relatives are blocked. However, more accurately, given our two slash elimination metarules, the ungrammaticality of 52 and 53 is predicted, because the 'gap' in these is in an NP position which *is not* governed by V, and gaps in NP positions are allowed insofar as these NPs are governed by V, otherwise we get a pronoun (see p.27 and 31).

2.4.1 'Complex' Adverb Phrases and WH Relatives

Apart from simple PPs as those in examples 49-51, there is a set consisting of what is called by the current grammar books of MG 'complex' adverbs (or 'complex' prepositions: see 3.7). These consist of an adverb followed by a preposition: *brosta apo* (in front of), *mazi me* (together with), *pano se* (on (to)), *pano apo* (over), *mesa se* (in (to)) etc. To these, we can add 'complex' adverbs which are, in addition, preceded by a preposition, e.g. *apo exo apo* (from outside), *apo brosta apo* (in front of), *apo makria apo* (from far from) etc. Cf. the phrases:

55. To ktirio *brosta apo to opio*, stamatisa...
adv. PP (wh)
the building in front of the which stopped-I...
The building in front of which I stopped...
56. O nomos *simfona me ton opio* eyinan ola...
Adv PP (wh)
the law according with the which were done-all...
The law according to which everything was done...

57. O kipos apo exo apo¹⁰ ton opio perasa...

P Adv PP (wh)

the garden from-outside-from the which passed-I...

The garden outside which I passed...

With respect to relative clause formation, the syntax of these complex adverbials is not different from that of the RCs with a simple PP dependency. Since what is 'displaced' is again the whole Adv'' the rule expanding R with an Adv'' dependency will be similar to 54 (p.291). The difference is that now (i.e. in 55-56), the relativized constituent is an AdvP and not a PP (cf. below). I.e. the PP originates in a configuration looking more or less like:

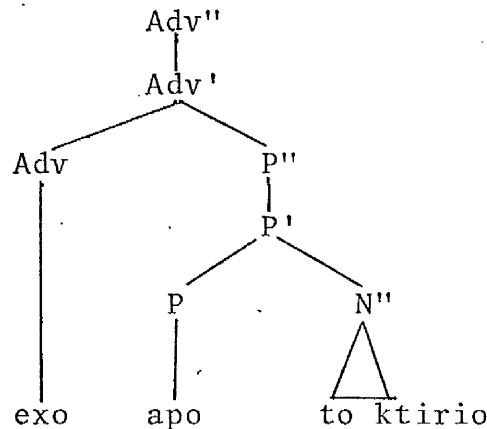

The more 'complex' adverbial of example 57 belongs to a structure like the following, for which rule 54 is appropriate again:

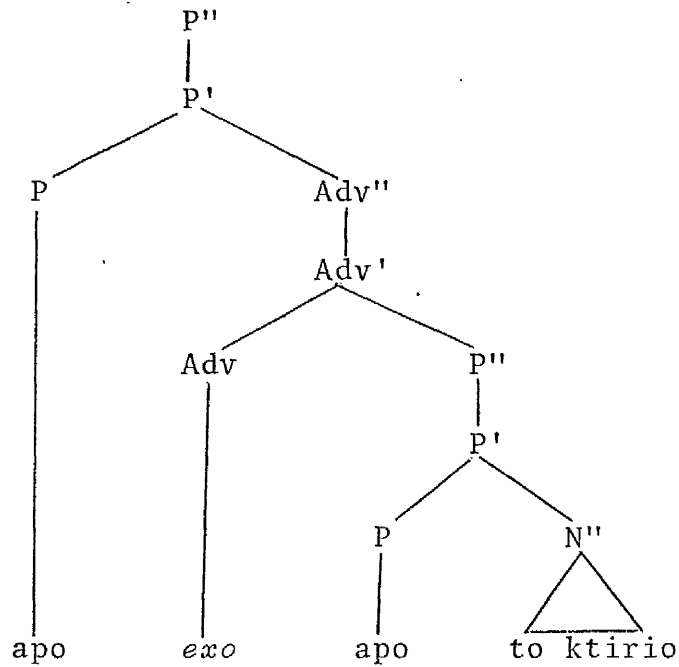

With regard to the first of the above two tree-diagrams, we must say that the 'gap' appears to be the whole Adv'' (cf. examples 55 and 56). This, however, may be misleading, since adverbs never relativize as such. Notice, though, that this is an instance of pied piping, and pied piping follows from the theory of foot features. Thus, [+wh+pro] are 'foot features', which ascend onto Adv'' from its complement P'', and, in turn onto P'' from its complement N'', by the Foot Feature Principle. See the following structure:

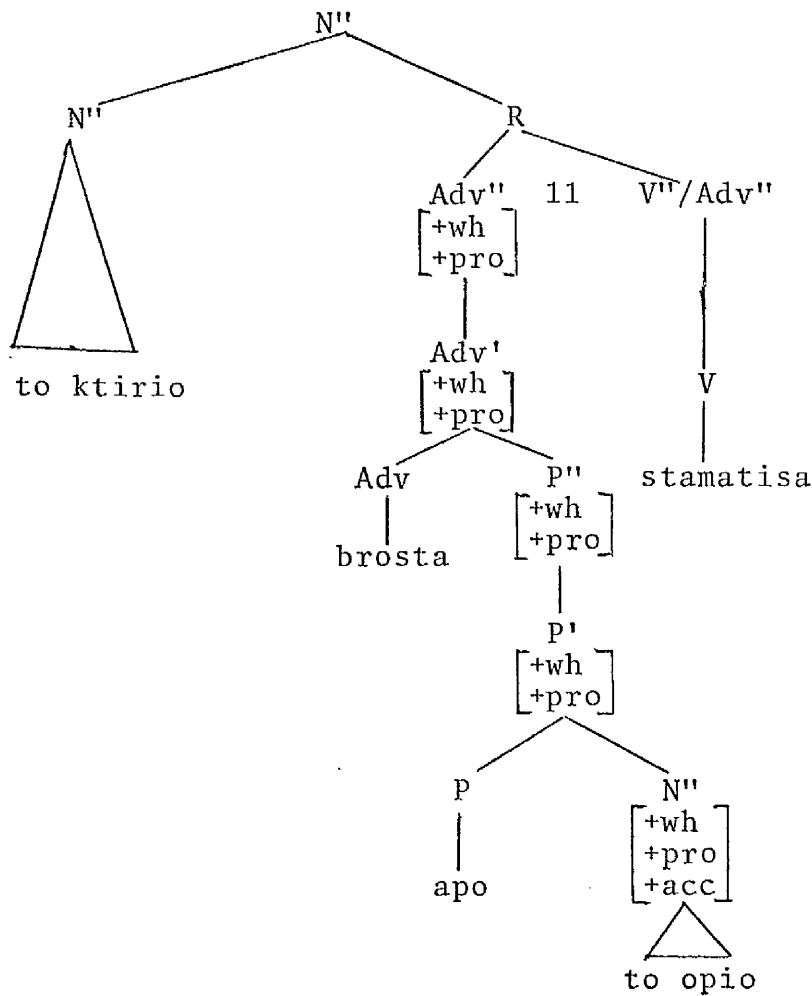

With reference to the tree diagram of p.294, the first thing to be stressed is that not only can the 'big' P'' be 'displaced' (as in 57), but also the lower one, occasionally, allowing, thus, for Adv' to appear on the projection path - as becomes clear from 58, for which, however, the judgments about its (absolute) acceptability vary:

58. ?O kipos apo ton opio perasa apo exo...
 the garden from the which passed-I from outside...

In parallel to 58 we can possibly get things like the example of note 11.

Now, besides the Adv'' *brosta apo to opio* we can also find *apo to opio brosta* - i.e. a sequence with the

PP preceding the AdvP. This inversion is very much reminiscent of the common topicalization process appearing in all PPs which are governed by AdvPs, independently of their participation in relativization; cf.:

- 59.a. (Apo) exo apo tin eklisia
(from) outside from the church
b. Apo tin eklisia (apo) exo
from the church (from) outside
- 60.a. (Apo) mesa apo to parathiro
from inside (from) the window
b. Apo to parathiro (apo) mesa
from the window (from) inside

Such examples can be further considered as parallel to:

61. O anthropos ekinos
the man that
62. Ekinos o anthropos
that the man
That man
63. To vivlio tu Yani
the book (of)-the John
64. Tu Yani to vivlio.
(of)-the John the book
John's book (cf. p.147)

2.4.2 Some clarificatory notes

At this point I ought to say something about the term 'complex' adverb which I have been using throughout

2.4.1. This is in contrast with the terminology of Jackendoff's X'-Syntax. The basic difference is that I have considered P'' as a complement of Adv , while the generalization of X is that [-Comp] categories do not strictly subcategorize anything. Consequently, strings corresponding to 59(a-b) are considered to be the result of the rule:

65. P' → P-PP (Jackendoff 1977:79).

I.e. what I call 'adverb' here is called 'preposition' by Jackendoff. The rule which fully expands P' runs as follows:

66. P' → P-(NP)-(PP).

Thus, if both NP and PP are present, phrases like *across the street from Bill's house* are generated. This treatment entails the following difficulty, calling 'adverbs' without *-ly* the plain P expansion, while the "expansion P-PP may use an intransitive preposition in the lower PP, as in *over here, from within* (Jackendoff, 1977:79). But *there* (like *here, outside* etc.) is called 'adverb' if it is the product of the P expansion. Along the same line, since [-Comp] categories do not have functional arguments, *rare* cases like *unfortunately for our hero* are instances of the rule

Adv'' → Adv'-(PP)

i.e. the PP is a complement in Adv'' as becomes 'indirectly' evident from examples in which a PP complement of A' can be preposed:

- 67.a. It was unfortunate for our hero that
Rome burned
b. For our hero, it was unfortunate that
Rome burned

whereas a PP strictly subcategorized by an adjective cannot:

- 68.a. Bill is dependent on John
b?*On John(,) Bill is dependent

I used the term adverb (Adverb Phrase) for the corresponding Greek examples following the widely and well established terminology of the classical and modern Greek grammars. Things like *mesa*, *exo*, *edho*, *eki* (within, outside, here, there etc.) are called 'adverbs'. Now, it is true that all the adverbs that dominate a PP in the above cited examples are adverbs of 'place' (i.e. locative), presumably corresponding to 'the class of adverbs without -ly' (cf. above). However, adverbs of, say, 'manner' (like the English 'unfortunately') can also dominate a PP, e.g. *dhistikhos ya to batera mu* (unfortunately for my father). Accordingly, I assume that (locative) adverbs are subdivided in intransitive (as in *piyene brosta* - go ahead) and transitive ones, in which case they subcategorize a prepositional phrase (e.g. *pano apo to trapezi*, *exo apo to spiti*); i.e. the choice of preposition in this case depends on the choice of Adv. That PP which is subcategorized by Adv (in other words, preceded or governed by Adv) can be 'contracted' to just a clitic pronoun (e.g. *pano sto trapezi/pano tu*, *mesa sta kimata* (see 70a-b)/*mesa tus*). Now, it is this fact that provides convincing evidence for our assumption that the maximal containing category is Adv, for objects of

prepositions are never reduced to clitics (cf. **apo tu*, **kata tu*, **se tu* etc.) (cf. also p. 344 onwards). Along the same line, we have to assume that the P" *ya to batera mu* after *dhistikhos* is not subcategorized by the particular adverb, because it cannot be reduced to a clitic (cf. **dhistikhos tu*). Rather, their relationship is a much looser one. However, whatever the preferred label for strings like *mesa se*, *exo apo* etc. is, this has no repercussions on their proposed syntactic account with respect to (wh-) relative clause formation. Namely, the label of the node Adv" may change, eventually, to P", but the tree-diagram itself will not.

However, with regard to these considerations about the exact labelling of such 'complex' adverbials, we can make the following distinction: first, there are adverbs (locative) which, by being added to a PP simply reinforce its meaning. This happens especially when the preposition is *se*, a very common preposition denoting place or direction. If an adverb is added to *se*, it makes the meaning of the preposition more explicit or more clear. But nothing essential changes if it is not added; cf.:

- 69.a. Pano sto trapezi (*sto* is the contracted form of the P *se* and the neuter definite article)
on onto the table
- b. Sto trapezi
(on) to-the table
On the table
- 70.a. Mesa sta kimata (*sta* is the contracted form of the P *se* and the neuter definite plural article)
in in the waves

- b. Sta kimata
in-the waves
In the waves

On the other hand, there is a majority of 'complex' adverbials, which have as a whole a different meaning from that of the dominated PP alone:

- 71.a. Zi makria apo to spiti tu
lives-3rd s. far from the house (of)-his
He lives away from his home
- b. *Zi apo to spiti tu
lives-3rd s. from the house (of)-his
- 72.a. Stathike exo apo tin eklisia
stood-3rd s. out from the church
He stood outside the church
- b. *Stathike apo tin eklisia
stood-3rd s. from the church

Here the adverbs *makria* (away, far from) and *exo* (outside) cannot be considered as 'additional'-optional-elements that simply intensify or clarify the meaning of the following preposition, because, evidently, they participate in the subcategorization of the verb, which was not the case with the adverbs of examples 69-70. In the light of this difference, the adverbial sequences of 69-70 look more like what can be called 'adverbial prepositional phrase'. But these are rather descriptive labels, and I find difficult to incorporate these considerations into the formal structural representation of examples like 55; thus it may be simply proposed that a feature [+P] under the higher AdvP node can be used for these adverbs that dominate a (locative) prepositional phrase like that of 69-70.

2.5 WH Relatives with a possessive genitive dependency

These are illustrated in the following examples:

73. O kirios o pateras tu opiu erghazete...
 the man the father (of)-the whose works...
 The man whose father works...
74. O kirios tu opiu o pateras erghazete...
 the man (of)-the whose the father works...
 The man whose father works...
75. O kirios i adherfi tiz yinekas tu opiu
 erghazete...
 the man the sister (of)-the wife (of)-the whose
 works...
 The man whose wife's sister works...

Let us first draw the tree showing the structure of 73:

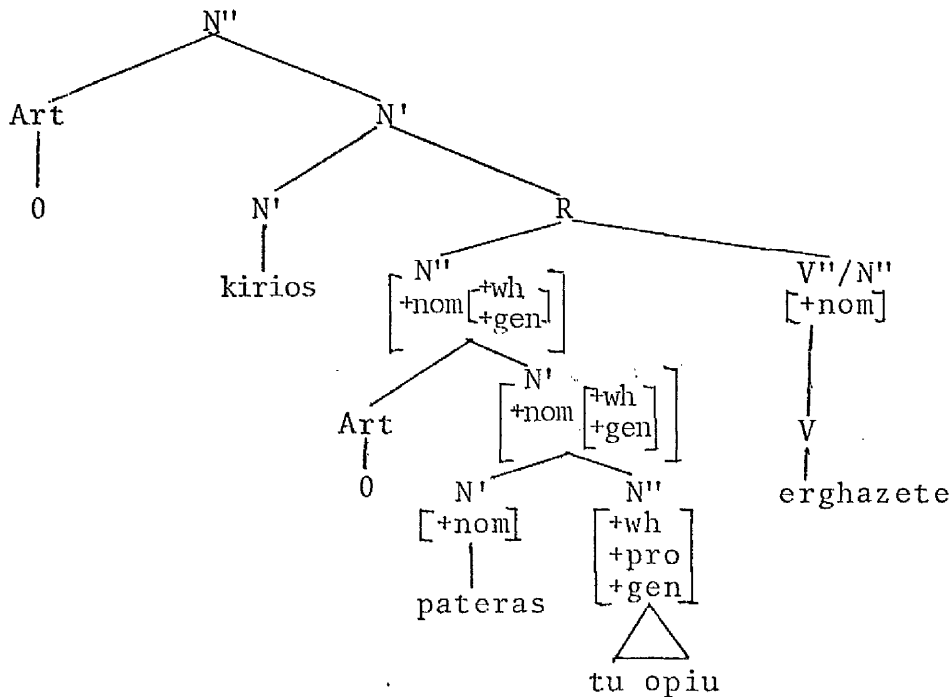

In this tree-diagram, the feature [+nom] descends from the higher N' node onto the N which is the controller of the gap within the relative (i.e. the missing subject); namely, it is a head feature. This is performed according to the Head Feature Convention. On the other hand, the foot feature [+gen] ascends from the complement NP onto the higher containing N' node; it is in the genitive case since it is a 'possessive' complement. This is accomplished by the Foot Feature Principle. The feature [+WH] is a foot feature, too. In 74 the left daughter of R appears in the reverse order with regard to the head noun and its complement. More accurately, the *wh*-genitival complement precedes the nominative head noun. This inversion must be similar with that noticed in the case of 'complex' adverbials (see p.295-296), and paralleled again to the inversion noticed in the examples 61-64. To account for this inversion we can either assume that the whole (definite) genitival complement of N' has appeared as the specifier of N' - since this 'dependency' is quite 'local'-- or, alternatively, handle it by a slash category, since this can explain the genitive case marking on the preposed *tu opiu*, in a configuration like the following:

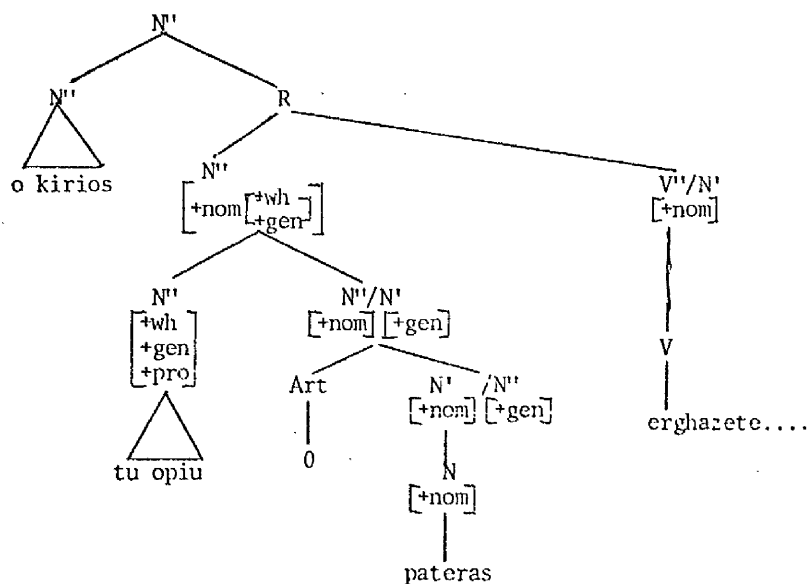

The feature [+gen] on the *wh*-pronoun derives from the fact that it is the 'displaced' complement of the nominative N'' *o pateras*; i.e. [+nom] is again a head feature, whereas [+wh +gen] are foot features, only that the complement to which these belong is 'preposed' (topicalized).

We can find still more complex *wh*-NPs such as that of example 75. The structure of this looks like the following:

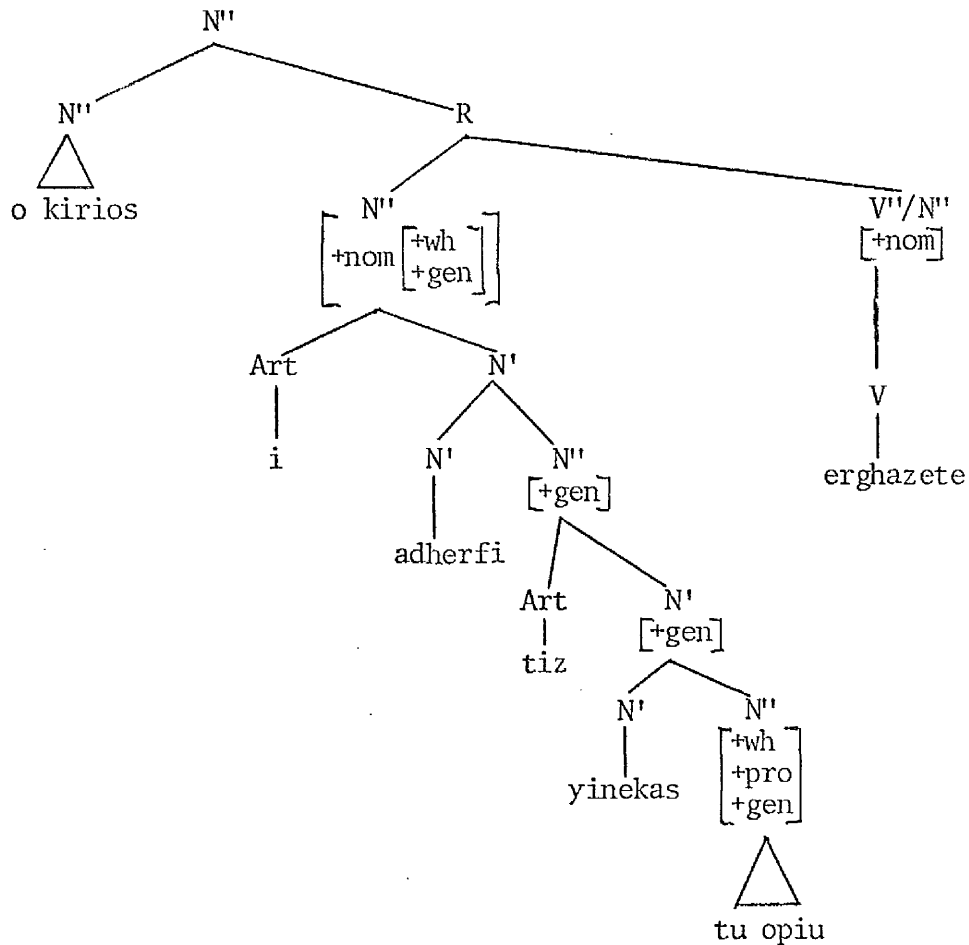

This structure, compared to that of page 301, contains an extra (embedded) N'' [+gen] node. The structure of

the 'topicalized' version of the *wh*-node¹² will be parallel to that of page 302 - with an extra genitival complement, too.

2.6 Evidence provided by cases of conjoined RCs

Having considered the internal structure of the *wh*-relatives with an object, subject, prepositional phrase¹³ and possessive genitive dependency, we shall see now that we get some independent evidence for the type of derived categories that account for the 'gaps' in the RCs in question, as we have so far assumed.

There are two basic principles crucial to the theory we employ here. The one, which concerns coordination, is that only *like* categories can be conjoined. The other is that slash categories are distinct from the corresponding non-slash categories. In other words, "subtrees that have a controlled hole in them are different from those that do not" (Gazdar 1981:28). Accordingly a V" with a missing NP will be a V"/N", not just a simple V" - .i.e. the two categories V" and V"/N" are not the same. Consequently, they are not allowed to be conjoined: *V" and V"/N" . Similarly, a V" is distinct from a V"/P" - a sentence with a missing prepositional phrase. The combined effect of these two principles accounts for the grammaticality or ungrammaticality of sentences produced by the conjunction of various sorts of RCs. Note first the following grammatical strings:

- 76.a. O kirios ton opio idhes ke su ekane
the man the whom saw-2nd s. and (to)-you-made-he
kali endiposi..... (V"/N" + V"/N")
good impression
The man you saw and who made a good impression
to you....
- b. O kirios o opios su edhose ta khrimata
the man the who (to)-you gave-he the money
ke idhes tikhea khthes sto spiti mu... (V"/N"+V"/N")
and saw-2nd s. accidentally yesterday in the house
(of)-mine
*The man who gave you money and you saw by chance
at my house yesterday
77. O kirios ton opio sinandises spiti mu ke
the man the whom met-2nd s. house (of)-mine and
su sistisa
(to)-you introduced-I...
The man you met at my house and I introduced to you

In 76a we have a RC with an object dependency conjoined with a RC with a subject NP dependency. In 76b the same types of RCs are conjoined but in the reverse order¹⁴. Given that RCs with object dependencies are of V"/N" type and that they can be conjoined with a RC with a subject dependency, it follows that the latter must be of the category V"/N", too. Needless to say, sentences like 77, with two conjoined RCs with object dependencies, or with two conjoined RCs with subject dependencies, can also be coordinated. It is also predicted by the aforementioned principles that a V"/N" cannot be conjoined with a V"/P" or vice versa. This seems in fact to be the case; cf.:

78.a. ?Afto ine to makheri to opio mu
this is the knife the which (to)-me
edhoses ke ekopsa to psomi
gave-2nd s. and cut-I the bread
This is the knife you gave me and I cut the bread with

b.* Afto ine to makheri me to opio ekopsa to psomi
this is the knife with the which cut-I the bread
ke eplina¹⁵
and washed-I

*This is the knife with which I cut the bread
and washed

79. *Aftos ine o kathiyitis o opios milise toso orea
this is the professor the who spoke so nicely
ke edhosan sinkharitiria
and gave-3rd pl. congratulations
This is the professor who spoke so nicely and who
was congratulated

In 78 we have a RC with an object dependency conjoined with a RC with a PP dependency, in both possible orders; i.e. a V"/N" conjoined with a V"/P". That is why 78a-b is generally bad. In 79 we have the same categories - as in 78 - conjoined, except that the V"/N" represents a subject instead of an object dependency. Clearly, these two different categories cannot appear coordinated, since in that case the 'same category' principle of coordination is violated¹⁶. As expected, two relatives with a PP dependency can be coordinated. But in this case 'sameness' must also extend to the choice of the particular preposition. More precisely, the preposition in each conjunct has to be the same, as the following examples suggest:

80. *O kirios ston opio edhosa to vivlio
the man to the whom gave-I the book
ke pira lefta...
and took-I money...
The man whom I gave the book to and from whom I took money...
81. *I politiki ya tin opia dhen itan ikanos ala zuse
the politics for the which not was-3rd s. able
but lived-3rd s.
Politics, for which he was not suited but by
which he earned a living...
82. O ipalilos me ton opio sinerghazomuna khronya
the clerk with the whom collaborated-I years
ke malos askhima khthes...
and quarelled badly yesterday...
The clerk with whom I used to collaborate for years
and I quarelled badly yesterday...
83. To spiti sto opio emena khronya ke bika khthes...
the house in-the which lived-I years and entered-I
yesterday
The house in which I lived for a long time and
which I entered yesterday...

In 80 the preposition in the first conjunct is *se* (in, at), but the one missing from the second (and must be 'recovered') is *apo*, since the verb of the second conjunct subcategorizes for an *apo* and not *se* PP. (the fact that the 2nd conjunct can be read as a separate sentence in which the verb *pira* (took) is interpreted as intransitive rather is irrelevant to the point made here). Likewise in 81 the P in the first conjunct is *ya* (for) but the one missing in the second is *apo*, since the verb *zo* ('earn a living')

subcategorizes for an *apo* PP. With contrast to these bad examples, 82 and 83 are OK since the missing preposition of the second conjunct is the same as that of the first conjunct, because the verb of the second happens to subcategorize for the same preposition as the verb of the first conjunct. Thus, the preposition in 82 is *me* and in 83 *se*. Of course, in all four examples if the PP [wh] -with the appropriate preposition - is repeated in the second conjunct no problem arises, but this again is irrelevant to our discussion, since in that case two separate RCs are conjoined (i.e. we have two instances of R), whereas now we are talking of one instance of R as will become clear in the schematic diagram to follow (p. 311) (cf. notes 15 and 16).

If the analysis of the sentences containing a RC with an AdvP dependency is correct - i.e. if the category involved is indeed an AdvP (a complex adverbial) then we predict the ungrammaticality of the following sentences:

84. *?To ktirio brosta apo to opio perasa ke
the building in front of the which passed-I and
bika...
entered-I...
The building in front of which I passed and
(which) I entered...
85. * I thia mu apenandi apo tin opia meno
the aunt (of)-mine opposite of the whom live-I
ke ematha na ftyakhno musaka...
and learnt-I to make mousaka...
My aunt opposite of whom I live and from
whom I learnt how to cook the mussaka...

86. ??0 mathitis me ton opio kathomuna
the student with the whom sat-I
sto yimnasio ke dhanizomuna sinekhia vivlia...
in-the high school and borrowed-I continuously books...
The student with whom I used to sit in
the high school and from whom I used to
borrow constantly books....
(meant *apo ton opio dhanizomuna...*)
87. *To trapezi pano apo to opio kremete to
the table over of the which hangs the
polifoto ke metakinisa to tilefono...
chandelier and removed-I the telephone...
The table over which the chandelier hangs and from which
I removed the telephone (meant *apo to opio metakinisa...*)

The above examples show that a RC with an AdvP dependency - as in the first conjunct - cannot be conjoined with a RC with a PP dependency - as in the second conjunct - not even if the dominated PP of the AdvP and the plain PP of the second conjunct have the same preposition (as in 85 and 87). We obtain the same results if we reverse the order of the two conjuncts, i.e. if the RC with the AdvP dependency is the second conjunct. Reversing the argument, we can say that since 84-87 are bad, it is obvious that the categories that are coordinated are not the same. Thus, in 85, if the second conjunct was again a V"/Adv" - i.e. a RC with an adverb phrase dependency - the whole string would be grammatical (cf. *i thia mu apenandi apo tin opia meno ke parkaro sinithos to aftokinito mu* - where the same AdvP is missing and understood in the second conjunct). Nevertheless, an interesting fact is shown in the following examples:

88. To trapezi pano sto opio evala ti dileorasi
the table on to-the which put-I the TV
ke sinithizo na meleto...
and am-accustomed-I to study...

The table on which I put the TV and at which I
am accustomed to study

89. I fili mu mazi me tin opia meno
the friend(of)-mine together with the whom stay-I
ke pigha khthes ekdhromi...
and went-I yesterday excursion...
My friend I live with and with whom I
went yesterday on an excursion...

In 88 and 89 the simple PP can be understood (*sto opio* in 88, *me tin opia* in 89) as missing from the second conjunct (of course, the whole preceding AdvP can, as well), but this, instead of being considered as counterevidence to the above conclusion about the type of slash category in the second conjunct, lends more support to our view (cf. p. 300) that a class of 'complex' adverbials like *mazi me ton opio*, *pano sto trapezi* etc. are marked by the feature [+P], a feature enabling the relatives that contain them to be conjoined with another relative that contains just the dominated PP. Of course, as already said, the PP in the second conjunct must be the same, so in 88 and 89 above it is a particular preposition that is missing - that of the particular AdvP. Finally, a RC with an NP dependency (subject or object) cannot be conjoined with a RC with an AdvP dependency; cf.:

90. *To ktirio brosta apo to opio perasa ke
 the building in front of the which passed-I and
 khtistike perisi...
 was-built 3rd s. last year...
 *The building in front of which I passed and
 was built last year...

2.6.1 Summary

The above remarks about the conjoinability of two *wh*-relatives can be summarized as follows: the missing material must be the 'same' in each conjunct, otherwise one cannot work out the content of the second 'gap' from the content of the *o opios* phrase. The sameness requirement follows from (a) the theory of co-ordination of like categories only and (b) the fact that the semantics will then interpret *both* gaps as having the same content. Instances of conjoined slash categories under R can be schematized as in the following diagram:

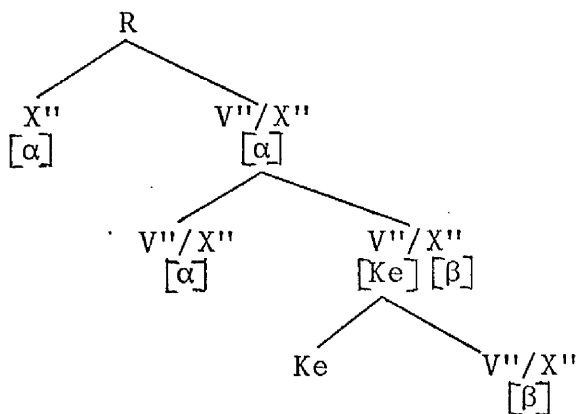

When $X''=N''$, then $\alpha=\beta$ in person, number and gender but α may or may not equal β in case. When $X''=P''$ then α must equal β (maybe α can differ from β if both can be assigned the feature [+locative], i.e. α and β can be different in some cases, but α can be 'recovered' if it agrees with β in the feature [+locative]). The same holds for Adv'' - i.e. when $X''=Adv''$, α must equal β . Put in words, things that follow from subcategorization of V in the second conjunct do not have to agree with things that follow from properties of the *wh*-phrase and/or subcategorization of the verb in the first conjunct - i.e. choice of 'case', and, in some cases, choice of preposition. Things that cannot be so predicted must follow from properties of the *wh*-phrase, e.g. choice of adverb, person/number/gender features; i.e. both conjuncts must agree with respect to these, because there is nothing in the second conjunct that could provide us with information about how to fill the gap in a way that disagrees with the first conjunct - no verb subcategorizes a particular adverb or requires a 3rd person, singular, masculine direct object etc. Thus, we see that our theory permits us to formalize with accuracy facts that can be also explained on a pragmatics/semantics basis.

Summarizing all the above data and incorporating all the information provided by cases of coordination, we are in a position to reformulate the two basic rules expanding R for *WH* relatives (with a subject, object, *PP*, *AdvP* dependency), collapsing them in the following - partly schematized-rule:

91. $R \begin{bmatrix} \alpha \\ [+wh] \end{bmatrix} V''/\alpha \begin{bmatrix} \\ [+wh] \end{bmatrix}$, where $\alpha \in \{N'', P'', Adv''\}$

The use of the variable α ensures that the 'gap' will be of one type only in conjoined relatives - as has been shown above to be the case. With regard to the obligatory pied-piping in *wh*-relatives, this can be accounted for by the slash elimination metarule I, which gives us gaps in NP positions governed by V. More precisely, *wh* is considered as a foot feature which ascends onto the maximal containing category that gets 'fronted'. Thus P" or N" will always be governed by V (cf. rule 91) - hence there will be a gap according to the slash elimination metarule I.

3. Non-WH restrictive relatives

3.1 *Pu* is a complementizer

Coming next to the non-*wh* RCs, i.e. *pu*-relatives, I shall anticipate what will become clearer in the discussion to follow of particular types of *pu*-relatives, by suggesting that *pu* should be considered as a complementizer rather than a pronoun. From a historical (diachronic) point of view, *pu* originates in the relative adverb (of place) *opu* (where). *Pu* is not marked for number, gender or case and cannot be governed by prepositions - unlike any other pronoun. *Pu* is also the complementizer that introduces complements of certain classes of verbs (like *leo* say, *nomizo* think, *vlepo* see, *katalaveno* understand). There are still other indications¹⁷ which show that *pu* cannot be treated as a pronominal alternative of *o opios*. It has been mentioned previously that instead of the genitive *o pateras tu opiu* we can equally have the (topicalized) inversion *tu opiu o pateras* (p. 302); this inversion is impossible in *pu* relatives (cf. *pu o pateras tu,* o pateras tu pu*). Moreover, as we shall see,

the presence of clitic pronoun is possible in *pu* Rs - sometimes optionally sometimes obligatorily - but this is impossible in WH-relatives (see note 9). Similarly, there are rare cases - not to be discussed here - where an emphatic full pronoun can turn up under specific conditions; cf.:

92.a.?To vivlio *pu afto* (ke okhi to X),
the book that *this* (and not the X),
aghorasa khthes...
bought-I yesterday...

No such possibility exists - not even marginal - in WH-relatives. In discussing the differences between appositives and restrictives, it was mentioned that in appositives we can have the emphatic sequence *ke aftos* (or *ke o idhyos*) (cf. p.267) - however this is only possible in *pu* and not in WH-relatives (cf. examples 14 and 15 of p. 267 and the ungrammatical **o opios ke aftos arkhise na...*).

Finally, there are cases where *pu* appears to be hardly related to any constituent of the introduced RC, so that far from being understood as a pronoun it looks more like a simple complementizer - a 'connector' so to speak of a (nominal) head and something predicated of it. Cf. the following extract of a newspaper, where *pu* can be freely interpreted as simply a relative 'marker', as an adverbial (*opu*), or as a PP (*stin* or *me* or *kata tin opia*):

93. *Frsika*, dhen itan to ifos tis sizitisis pu
of course, not was the style(of)-the discussion
katekrinan me khidhealoyia kataxiomenus
that ?? accused rudely respectable
iyetes...
leaders...
Of course, it was not the style of the discussion,
in which (where, by which) respectable leaders
were accused rudely

In this connection, we notice another difference between
wh- and *pu-*relatives; cf. 94¹⁸:

- 94.a. I fili mu i Maria, pu an dhen itan afti
the friend(of)-mine the Mary, that if not was this(she)
tha khanomun...
would perish-I...

- b.*I fili mu i Maria, i opia an dhen itan afti
tha khanomun...

My friend Mary, without whom I would perish

In 94a the presence of the emphatic definite pronoun
afti (cf. p.267) and the following rule of *pu-* relatives
with a subject dependency show that the status of *pu*
is closer to that of a complementizer than to that of a
pronoun.

3.2 *Pu*-RCs with subject dependencies

We shall begin our discussion of *pu*-relatives
with what appears to be the simplest case, that of a
subject dependency. Thus, sentences like:

95. O mathitis pu dhen xeri mathima...
 the student that not know-3rd s. lesson...
 The student that hasn't learnt his lesson...
96. O filoz mu pu erghazete sti drapeza...
 the friend (of)-mine that works at-the bank...
 My friend who works at the bank...

are not structurally different from the corresponding WH-relatives. Consequently, the rule expanding R in this case will be:

97. $\begin{matrix} R \\ [-wh] \end{matrix} [pu \ V''/N'']$

The V''/N'' category will guarantee that the following are blocked:

98. *O filoz mu pu o pateraz mu erghazete
 the friend-(of)-mine that $\left\{ \begin{array}{l} \text{the father (of)-mine} \\ \text{aftos} \\ \text{that} \\ \text{egho} \\ \text{I} \end{array} \right\} \begin{array}{l} \text{works} \\ \\ \\ \text{erghazome...} \\ \text{work-I} \end{array}$

3.3. Pu-relatives with a direct object dependency

These are shown in the following examples:

99. To vivlio pu dhyavasa...
 the book that read-I....
100. I filii mu pu sinandisa khthes...
 the friend (of)-mine that met-I yesterday...
 My friend that I met yesterday...

First of all, with regard to 99 and 100, I am assuming, given what was discussed in 1.2 about the differences between restrictives and appositives, that the clitic pronoun does *not* appear in restrictives. This will be further discussed in a separate paragraph below. Now we shall only be concerned with the internal structure of relatives like 99 and 100. The rule accounting for them must be 101.

$$101. \quad \begin{array}{c} R \\ [-wh] \end{array} \quad [pu \quad V''/N'']$$

101 is the same as 97, the difference lies in the choice of the case feature under N'', although there is really no need for any case feature in these rules. The slash elimination metarule

$$V'' \rightarrow V, \quad \begin{array}{c} (N'') \\ [nom] \end{array}, \quad \begin{array}{c} (N'') \\ [acc] \end{array} \Rightarrow V''/N'' \rightarrow V, \quad (N'')$$

will simply eliminate any one of the NPs allowed in the subcategorization frame of the V - it may be [nom] or [acc] I.e., the N'' left after V in the second part of the metarule will be either [nom] or [acc]. Therefore, the slash elimination metarule I handles both types of RCs - subject and object dependency ones. We could, in the interests of generality, have always a case feature, but in this case it is not strictly necessary, since the choice of case is *free*.

Now, the V''/N'' category will prevent the following from being generated:

| | | |
|-----------------------------|---|-----------------|
| 102. *To vivlio pu aghorasa | } | to mithistorima |
| the book that bought-I | | the novel |
| | | afto |
| | | this |

as required by the slash elimination metarule I.

3.4 Pu-relatives with a possessive genitive dependency

These present more interest with respect to their structure. Such dependencies into genitive NPs can appear in larger NPs that represent subjects, objects or whatever. Example 103(a-b) illustrates a case of a genitive dependency within a subject NP:

- 103.a. O kirios pu o pateras tu erghazete...
the man that the father(of)-his works...
- b. O kirios pu erghazete o pateras tu...
the man that works the father(of)-his...
The man whose father works...

while example 104 shows a case of a genitive NP dependency within the object NP:

- 104.a. O kirios pu to onoma tu xekhno...
the man that the name (of)-his forget-I...
- b. O kirios pu xekhno to onoma tu...
the man that forget-I the name (of)-his...
The man whose name I forget...

Let us first consider the structure of 103a.

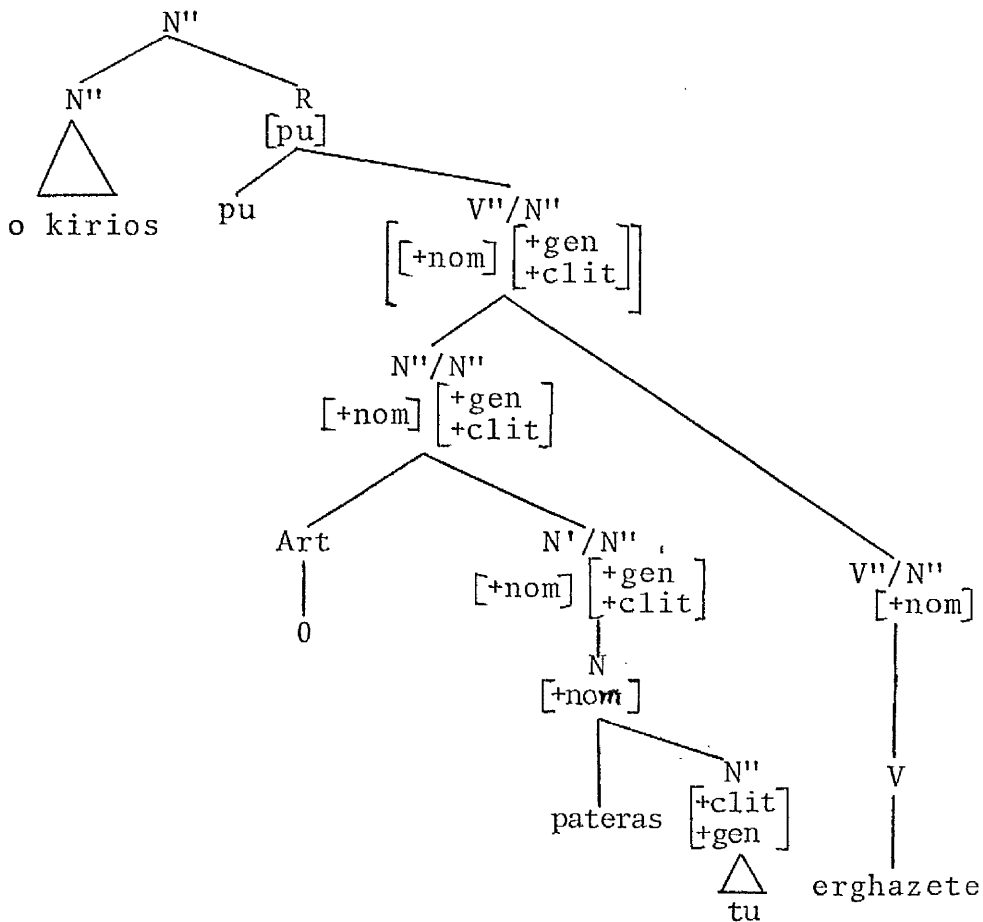

The following are in order concerning this structure: first, the existence of the 103b version of 103a strongly suggests that *pu* and the NP *o pateras tu* do not form a constituent. This follows automatically from the treatment of *pu* as a complementizer and not as a pronoun. In corresponding wh-relatives, the wh-pronoun and the subject NP formed a single constituent. Second, again since *pu* is not a pronoun (like *tu opiu*), no material can be pied-piped; cf.:

105. *o kirios o pateras tu pu... (cf. p. 313)

This means that we have to allow for NP dependencies into

constituents that do not allow for such dependencies in wh-relatives. And with this remark we come to an important point. Notice that the genitive clitic pronoun *tu* is indispensable in 103(a-b) as well as in 104(a-b). It appears that this clitic is what 'connects' the head NP (here *o kirios*) with the RC through the complementizer *pu*. This suggests that the clitic in such restrictive relatives must be treated as syntactically bound - just like gaps - and accounted for by the same syntactic mechanism. To this effect we shall employ the slash elimination metarule II by which we shall get the obligatory clitic pronoun in 103-104(a-b). This rule is stated as follows - for dependencies into genitival complement NPs:

$$\begin{array}{c}
 N' \rightarrow N, N'' \\
 \left[\begin{array}{c} +gen \\ +clit \\ +pro \end{array} \right] \\
 \Rightarrow \\
 N' / N'' \rightarrow N^*, N'' \\
 \left[\begin{array}{c} \alpha \text{ person} \\ \beta \text{ number} \\ \gamma \text{ gender} \end{array} \right] \left[\begin{array}{c} +gen \\ +pro \\ +clit \\ \alpha \text{ person} \\ \beta \text{ number} \\ \gamma \text{ gender} \end{array} \right]
 \end{array}$$

The feature combination under N'' will block strings like:

| | |
|---|--|
| <p>106. *.....<i>pu o pateras</i> that the father</p> | $\left. \begin{array}{l} \text{aftu} \\ \text{(of)-his} \\ \text{emena} \\ \text{(of)-mine} \\ \text{tu Kosta} \\ \text{the (gen) Kosta} \end{array} \right\}$ |
|---|--|

* I assume that clitics appearing as complements of nouns are *phonologically* attached to N (it should be noted that as such they form a single intonation unit with the noun to which they are attached). This means that genitival clitics are not sisters of N' , as other possessive complements of nouns are, but of N, so the above metarule can apply without problem.

As for the feature [clit], it must be stressed that it appears on genitival complements independently of RC formation; thus, it can also be included under N" in the first part of the above metarule. With regard now to the different way that genitival complements are relativized in *wh*-and *pu*-relatives, we can say, in connection with what is said on p.313, that some kind of the A-over-A principle may give the right result - i.e. *wh* is a foot feature which ascends as high as it can, and it is the largest containing category that gets 'fronted' (cf. *tu opiu o pateras/o pateras tu opiu*); this guarantees all such N" will be governed by V (therefore there will be traces according to the slash elimination metarule I). There is no *wh*-feature in *pu*-relatives, so the dependency can go down deeper than V" into complements of V' or V and this results in resumptive pronouns.

Example 104a-b is a case of a genitival dependency within an object NP. 104a is assigned the following structure:

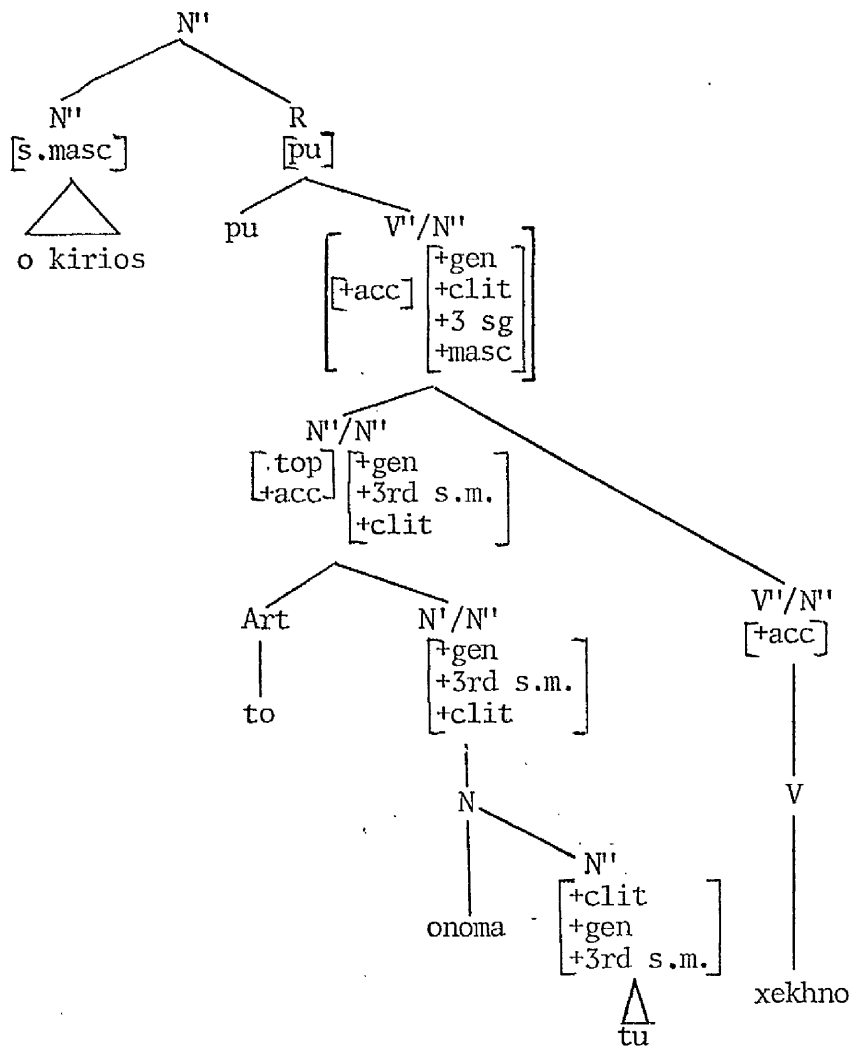

First, there is strong evidence that the N'' on the left of the slash is a topicalized constituent here. This is the appearance-optional-of the object clitic before the verb:

107.pu to onoma tu to xekhno...

If this 'displaced' NP acquires emphatic stress, then it is marked as focus and the clitic cannot show up. The feature [+acc] is a head feature, accounted for by the HFC; the [+gen +clit...] are foot features ascending onto N'' by the FFP. In 104b, on the other hand, the object N'' (i.e. the N'' [+acc]) is in its non-topicalized

('original') place, therefore we will get a dependency within the object NP position, which is not 'fronted', as shown in the following tree-diagram:

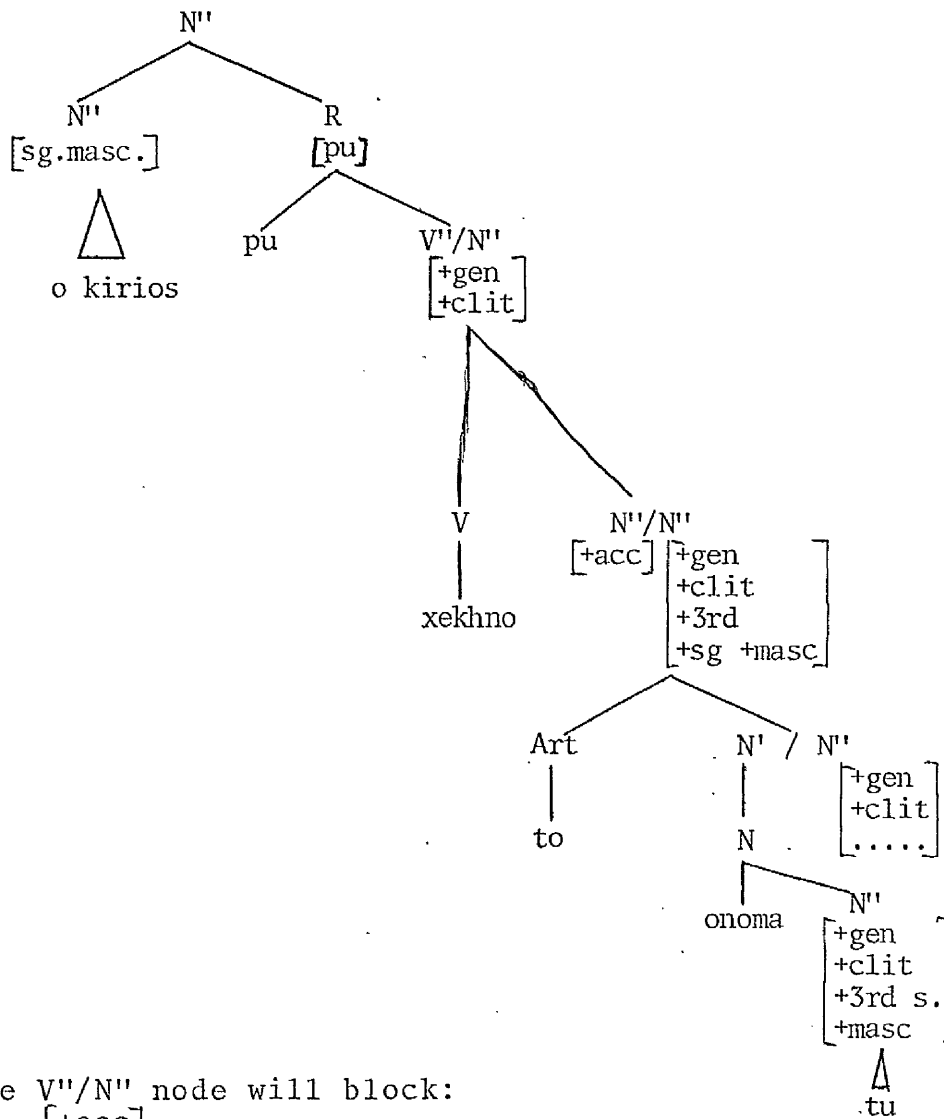

The V''/N'' node will block:
 [+acc]

108. *O kirios pu to onoma tu xekhno
 the man that the name (of)-his forget-I

| |
|--------------------|
| to batera tu |
| the father(of)-his |
| esena |
| you |
| |

while the V"/N" [+gen +clit] will block:

- 109a. *O kirios pu xekhno to onoma
- | | |
|----------------|---|
| su | } |
| (of)-yours | |
| tu Kosta | |
| (of)-the Kosta | |

3.5 Pu-relatives with an indirect object dependency

The following examples exhibit such relative clauses:

110. To koritsi pu tu edhosa to vivlio mu...
the girl that her gave-I the book(of)-mine..
The girl to whom I gave my book....
111. Mnya yineka pu tis aferesane ti mitra
a woman that her removed-3rd pl. the womb
A woman whose womb was removed
112. I kopela pu tis dhiiyithika to pathima mu...
the girl that her told-I the misfortune(of)-mine
The girl to whom I told my misfortune...
113. O katighorumenos pu tu epevalan varya pini
the defendant that him imposed-3rd pl. heavy penalty
The defendant on whom a severe penalty was imposed.
114. O mathitis pu dhen tu epetrepsan na dhi to ergho
the pupil that not him allowed-3rd pl. to see
the play
The pupil who was not allowed to see the play.
115. ...san du skilu pu tu dhenis ti bliyi...
...like(of)-the dog that him bandage -2nd s.
the wound...
...like a dog whose wound is bandaged...

116. O kirios pu tu dhanisa khrimata
the man that him lent-I money
The man to whom I lent money

3.5.1 Some general remarks

The first thing to observe in the above examples is the presence of the IO clitic pronoun. This contrasts with the situation that exists in restrictive relatives with a DO dependency - all of the above are restrictive RCs. The facts become even more puzzling if we take into consideration the fact that the clitic pronoun can be omitted in most of the 110-116 without any further consequence, either with regard to the meaning or with regard to the status of the RC. Thus, in 110,112,114 (perhaps with a?) and 116 the clitic pronoun can be absent, whereas in all the rest its omission renders the resulting sentence ungrammatical. The curious thing is that the possibility of the clitic appearing in this sort of relatives does not depend on whether or not the verb governing it strictly subcategorizes an argument or not. So, in all of the cases where the pronoun can be omitted, the verb subcategorizes an NP. In 113, where the omission of the pronoun results in ungrammaticality, the verb also subcategorizes an NP. Consequently, any attempt to explain facts simply on terms of subcategorization is clearly ineffective. On the other hand, in 111 the clitic represents not so much an IO, as what can be called an 'ablative genitive' (note that in the corresponding WH-Relative, we would have the preposition *apo* (from):.... *apo tin opia aferesane*). As for 115, the clitic here stands for what has been called a 'benefactive' dative. The verb does not necessarily subcategorize for an IO (*tu* corresponds in 115 to the preposition

ya (for) or *se* (to, for). In other words, 111, 113, 115 involve something more than simple indirect objecthood. Perhaps it is the same formal type of preposition as we get after verbs like *exartome apo* (depend on), *endhyaferome ya* (be interested in). We shall give a formal account of these facts below, after we give some explanation which accounts for the presence or absence of the clitic pronoun in relatives with 'IO' dependencies. This explanation makes use of the Accessibility Hierarchy as presented by Keenan and Comrie. The claim is made there - based on the data from a large number of languages - that not all the NP positions can relativize in all languages. The 'hierarchy' of relativization is shown in the schema:

SU > DO > IO > OBL > GEN > OCOMP

(where SU is subject, OBL 'oblique cases', OCOMP object of comparison). The difficulty in relativization proceeds from left to right - i.e. all languages relativize subject NPs but very few objects of comparison. The same hierarchy holds within one and the same language. Thus, different strategies are employed by a language, depending on which NP positions are relativized (cf.: "the relativizability of certain positions is dependent on that of others;... these positions specify a set of possible grammatical distinctions that a language may make" (K. & C. 1977:66)). Following their arguments and data, we can say, with respect to our own data, that since IO NPs are relatively low in the hierarchy - anyway, after DO NPs - in other words, since IO NPs relativize with a greater difficulty than DO or SU NPs (the term 'difficulty' refers to the comprehensibility of the relativized NP), it is natural for the language to employ

a device which will 'cope with' this difficulty. Thus, "several languages have recourse to a case-coding strategy for positions low on the AH (e.g. genitives), whereas the strategy for major NPs is not case-coding" (K. @ C. 1977:67). The use of the clitic pronoun in the examples discussed is certainly one such case-coding strategy; cf.: "in addition to the use of the relative pronouns, case can be coded by a personal pronoun that can be present in the NP position relativized" (ibid.p.66). Along this line, we can more or less give an explanation of why in some cases the pronoun can be omitted. It may be that this particular strategy for forming RCs in that position is on its way towards being eliminated, in which case the formation of IO relatives will be assimilated to that of DO ones (i.e. without the resumptive pronoun), or, equally well, to that of relatives with a PP dependency, as will be seen in the next paragraph. Thus, it may not be a mere coincidence that in most of the cases where the IO clitic is omitted, the verb strictly subcategorizes an IO. Therefore, this object is easily 'recoverable' - to use a well-established term. It is also important that datives of the type called 'benefactive' etc. belong to the position of the hierarchy scale labelled OBL - i.e. one step lower than IO¹⁹. And it is exactly the clitic pronoun representing such datives that is not normally omitted²⁰ (see also 3.8 and 3.9 below): To sum up, relativization in IO position takes place in a way similar to that in DO position - i.e. *without* a (clitic) pronoun. We shall propose a means to account for the optional clitic in such relatives. On the other hand, relativization in OBL position (by OBL, NPs that are arguments of the main predicate - i.e. oblique case NPs - are designated) takes place in a way similar to that in GEN and OCOMP

positions (cf. p. 352) - i.e. with an obligatory pronoun. This is natural, since OBL follows IO, i.e. it is lower than IO on the AH scale (cf. p. 326).

3.5.2 A syntactic account of 'indirect object' relatives

Independently of the explanation of the presence/absence of the clitic pronoun in restrictives with an indirect object dependency, we must afford a mechanism to account for it. The mechanism in question involves again the slash elimination metarule I, by which we get a dependency into an NP position governed by V, and for that reason resulting in a gap. Strings containing an optional clitic must be related to 'clitic doubling', a process independent of relativization. The clitic pronoun appearing in the strings under discussion is in the genitive case. This follows from the fact that indirect object NPs can also appear as genitive NPs, thus the clitic that 'doubles' this NP must be in the genitive case, too. Accordingly, we must have a metarule mapping rules that contain a PP (cf. p. 24) to rules that contain a genitive NP; this rule is written as follows:

$$117. \quad V' \left[V \ X \ \begin{array}{c} P'' \\ [F] \end{array} \right] \Rightarrow V' \left[V \ X \ \begin{array}{c} N'' \\ [+gen] \end{array} \right], \text{ where}$$

F stands for a particular (strictly subcategorized) preposition (like *se*, *apo*, *ya* etc.). This metarule yields the alternating strings

- 118.a. Edhosa X stin Y
 gave-I X to-the Y
- b. Edhosa X tis Y
 gave-I X (of)-the Y

Next, we have the clitic doubling rule operating on rules with a genitive NP:

$$119. \quad V' \left[\begin{array}{l} V, X \\ N'' \\ [-pro] \\ [+gen] \\ \alpha \end{array} \right] \Rightarrow V' \left[\begin{array}{l} V \\ [+gen] \\ \alpha \end{array} \right] X \left[\begin{array}{l} (N'') \\ [+gen] \\ \alpha \end{array} \right]$$

where α stands for object features spelled out as a proclitic pronoun (cf. Horrocks 1983:198); namely, the relevant rule 'expanding' V is $V \rightarrow \text{clit} + V$.
 This metarule will yield: $\langle \alpha, \beta \rangle \left[\begin{array}{l} \alpha \\ \beta \end{array} \right]$

- 120.a. Edhosa X tis Y
 b. Tis edhosa X (tis Y)

The above two rules account for all the options. The clitic doubling rule gives us a structure like the following:

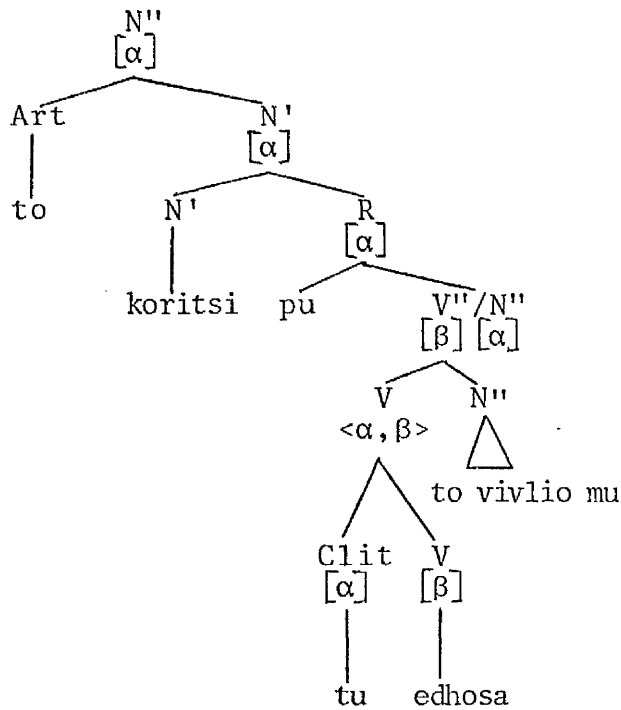

Thus, we get a 'gap' where N'' [-pro] would have been, and we can get a clitic 'double' left-over, but that is the result of an optional rule, not of slash elimination. So far, we have accounted for the 'gap' in IO position in *pu*-relatives and the optional appearance of the clitic pronoun in that position. The 'gap' is guaranteed by the slash elimination metarule I, which yields a gap in NP positions governed by V, the optional clitic is taken care of by the optional-independently motivated-rule of clitic doubling.

Rule 117 applies also in cases of an OBL(ique) NP, due to the feature F of P'' (see p. 328). OBL(ique) cases - i.e. subcategorized PPs other than IO (such as those which are traditionally called 'benefactive', 'disadvantage', 'ablative' datives) also alternate with a genitive NP, exactly as shown in 121, cf.:

- 121.a. Aferesa X apo tin Y
removed-I X from the Y
b. Aferesa X tis Y
removed-I X (of)-the Y

But the difference in such cases lies in the fact that, as already pointed out previously, the clitic pronoun is no longer optional but rather obligatory; as expected, of course, since now we are further down on the 'hierarchy'. Therefore the clitic doubling rule is inoperative here. Within the present formulation of our grammar there is no straightforward way which can account for these cases. Even if we relaxed the constraint that gaps be only governed by V, and allowed for W in the SEM II to stand for V as well, that, still could not account for cases like those of examples 111 or 115, since the SEM II cannot be used for *pre-verbal* clitics but only for post-head complements, as we have already seen. Therefore, since, in any case, this constraint on gaps seems well-motivated on independent grounds, I am confined to explain the 'obligatoriness' of clitic doubling in terms of the AH facts, as I have already done, even if I do not afford a means to account for it syntactically.

3.6 Conjoined DO and IO RCs

We claimed in 3.5 that restrictive relatives with an IO dependency involve a V"/N" category. This predicts that such relatives can be conjoined with other V"/N" relative clauses, i.e. with relatives containing a subject or object dependency. In fact this is attested in the following examples:

122. O nearos pu ghnorisa khthes ke (tu)
the young man that met-I yesterday and (him)
dhanisa khilyes drakhmes...
lent-I thousand drachmas...

? The young man I met yesterday and lent a
thousand drachmas

123. I mathitria pu irthe spiti mu ke (tis)
the student that came-3rd s.house(of)-mine and (her)
edhosa vivlia
gave-I books
The student that came to my house and to whom
I gave some books

Dependencies into OBL position must be of the V"/N" category, too, independently of their exact syntactic account. This is strongly suggested by examples like:

124. O katighorumenos pu tu epevalan varya
the defendant that him imposed-3rd pl. heavy
pini ky estilan
penalty and sent-3rd pl.
exoria sti Yaro dhrapetefse
exile to-the Yaros escaped
The defendant who had a severe penalty imposed
on him and was exiled to Yaros escaped

125. ...san du zou pu plighonete ke tu
...like(of)-the animal that is wounded and it
dhenis ti bliyi
bandage -2nd s. the wound
Like an animal that gets wounded and its wound
is being bandaged

The clitic (obligatory) in 124-125 is syntactically bound, i.e. equivalent to a gap; this allows a RC with an OBL dependency that contains it to be conjoined with a RC involving an 'ordinary' NP gap.

3.6.1 A note on some 'idiosyncratic' cases of coordination

There is a set of examples which at first sight appear to provide counterevidence to our claims made so far about the presence/absence of the resumptive pronoun in DO and IO dependency *pu*-restrictive relatives. Such examples are illustrated below:

126. I kopela pu ipes tinistoria su ala
the girl that told-2nd s. the story(of)-yours but
dhen din xeris
not her know-2nd s.
The girl to whom you told your story but whom
you don't know

127. O anthropos pu tu epevalan pini ke ton
the man that him imposed-3rd pl. penalty and him
estilan exoria...
sent exile..
The man on whom a severe penalty was imposed
and who was sent to the exile

Examples 126-127 show that our analysis of DO *pu* relatives *not* involving a clitic is incorrect; yet, there are similar examples that suggest that the second conjunct must be considered as a separate sentence, in which case the clitic contained in it has nothing to do with RC formation, but is simply used to recall the NP about

which we are speaking; thus cf.:

128.a. Aftos ine o filoz mu pu (tu) dhanisa
this is the friend(of)-mine that (him) lent-I
to vivlio mu ke ute to idha xana
the book (of)-mine and not it saw-I again
This is my friend to whom I lent my book and
I never saw it again

b. O anthropos pu tu epevalan pini ke tin
the man that him imposed-3rd pl.penalty and it
exetise s ena khrono
payed-off-3rd s. in one year
The man on whom a severe penalty was imposed
and he payed it off in one year

In 128a-b the second conjunct cannot be a RC, since the clitic pronoun refers back to the 'book' or 'penalty' (notice their gender agreement), whereas the first conjuncts-which contain a RC - are about *my friend (o filoz mu)* or *the man (o anthropos)* respectively. Clearly then, this is not 'conjunction' of equal elements in the normal way. The second conjunct gives additional information about a constituent of the first conjunct other than the head of the RC, so that we are forced to consider the whole as a conjunction of two *sentences*. The following tree illustrates that:

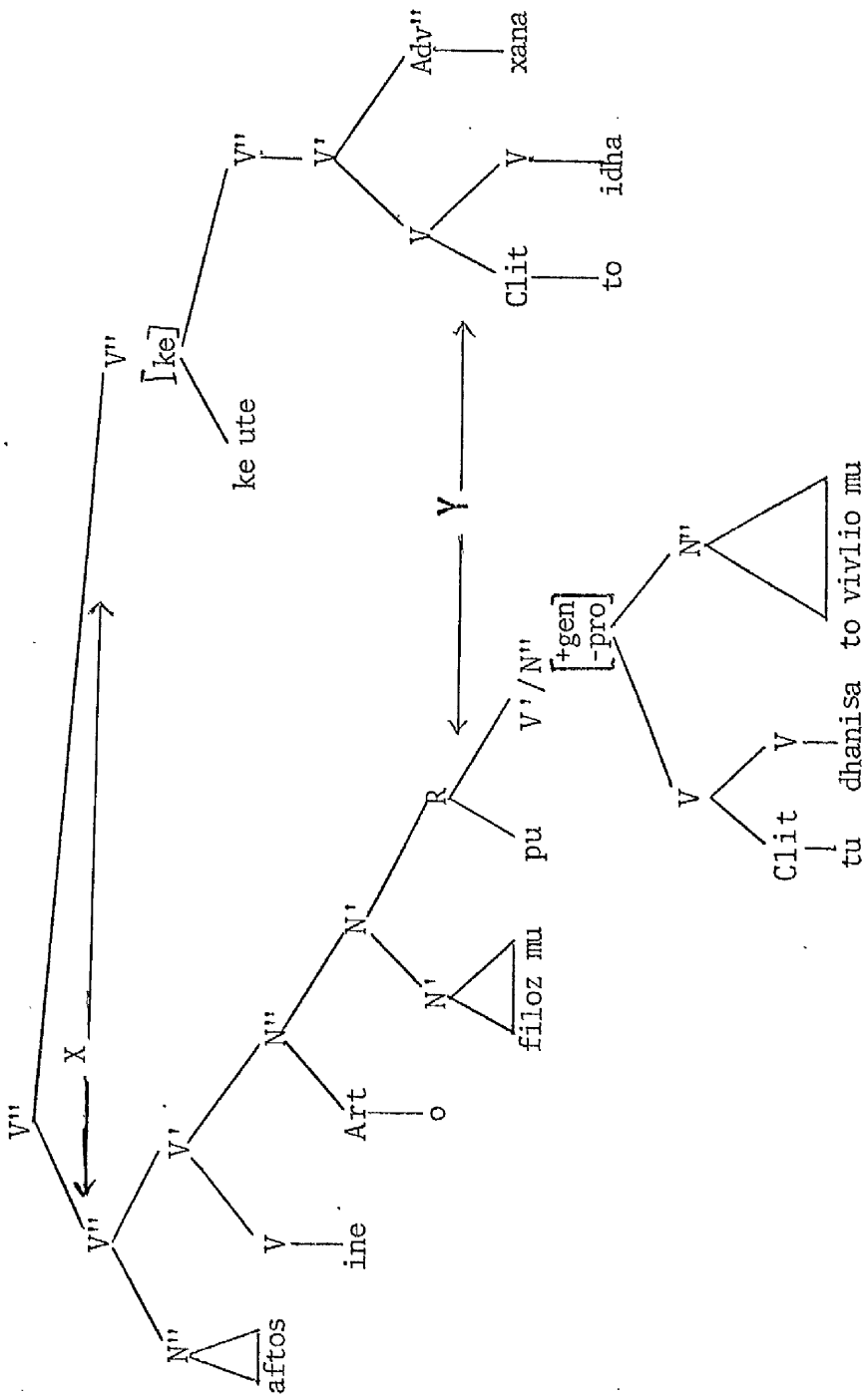

The conjunction is at point X, not Y, in the above diagram. Consequently, we can maintain our claims about the absence of a resumptive pronoun in restrictive relatives with a direct object dependency (cf. note 5) and its optional presence in relatives with an indirect object dependency. In the light of 128a-b we can consider the second conjunct in 126-127 as a separate sentence, in a structure like the one drawn above, which simply happens to add information about the head noun of the RC of the first conjunct. The same explanation accounts for conjoined types of sentences in which the first conjunct contains an unambiguously restrictive direct object relative, whereas the second conjunct looks like the first but contains the object clitic pronoun; e.g.

129. Afto ine to vivlio pu aghorasa ke to
this is the book that bought-I and it-
kharisa stoYani
offered-I to the John
This is the book I bought and I gave it
to John

3.7 Pu-relative clauses with a PP dependency

3.7.1 General remarks

There are two major contributions to this topic, the one is an article by G. Horrocks and G. Gazdar (1981), motivated as an answer to B. Joseph's article 'Recovery of information in relative clauses: evidence from Greek and Hebrew' (*Journal of Linguistics* 16:237-244); the other is an unpublished paper by D. Theophanopoulou titled 'MG pu Relative Clauses and the omission of the preposition'. The discussion that

follows is based on these two works.

Pu relatives with a PP dependency are basically different from the corresponding WH-relatives. They are formed in two ways, either with *pu* and a PP consisting of a P followed by a full (not clitic) personal pronoun, as in 130-131:

130. To spiti *pu s afto* yenithika gremistike...
the house that in it was born-I was demolished...
The house in which I was born was demolished
131. To makheri *pu m afto* ekopsa omorfa to kreas
the knife that with it cut-I nicely the meat
itan kritikos suyias
was cretan penknife
The knife with which I cut nicely the meat
was a Cretan penknife

or with *pu* and complete elimination of the whole PP, as in 132-133:

132. To spiti *pu* yenithika gremistike
133. To makheri *pu* ekopsa omorfa to kreas itan kritikos suyias .

Theophanopoulou points out that this second way is more restricted than the first one (or the corresponding WH Relative) in cases of ambiguous 'recovery'; this recovery depends on a complex of factors; we shall refer to them after we give an account of the syntax of the above examples.

3.7.2 An account of 'PP' dependencies in *pu*-relatives

For examples like 132-133 the following rule expanding R is appropriate

$$134. \quad \begin{array}{l} R \\ [-wh] \end{array} \quad [pu \quad V''/P'']$$

What we get in cases like those in 132-133 is just a 'gap' - nothing at all. Slash elimination metarule I ensures that. What about examples 130-131, in which we get a PP with a pronominal object ?

First of all, it must be noticed that in 130-131 what we get is a dependency of N'' within a P'' - i.e. we have a P''/N'' node. If the node in question was of V''/P'' type, that ought to result either in a P'' gap, as in the case of 132-133, or in a P'' proform (a 'prepositional pronoun'); but since there are no such proforms, what we get is a P followed by an N'' proform, i.e. what looks more like a V''/N'', where N'' goes down into a complement (PP) of V giving a pronoun. This is ensured by the slash elimination metarule II, written for this case as

$$P' \rightarrow P, \quad \begin{array}{l} N'' \\ [+pro] \end{array} \Rightarrow P'/N'' \rightarrow P, \quad \begin{array}{l} N'' \\ [+pro] \end{array}$$

Thus, W in the general rule schema of page 31 stands also for P. But since prepositions in MG are never followed by a clitic pronoun, the feature [+clit] is inappropriate in this case, in contrast with genitival (or IO) dependencies (cf. p. 320). Consequently, only [+pro] is needed to show that the N'' following P is just the 'full' pronoun *aftos*. Along these lines, the following structure is proposed for 130.:

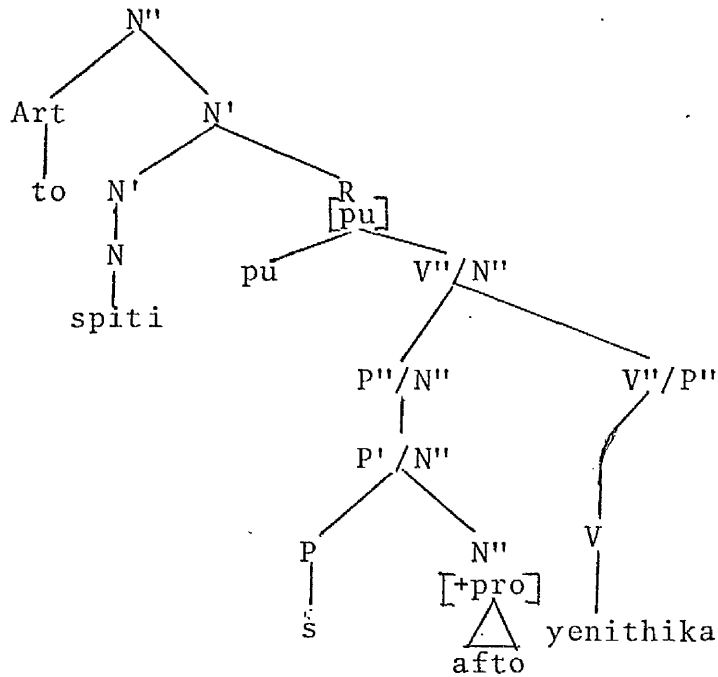

The V''/P'' node indicates that a PP is missing - this is the PP that appears *before* the verb, i.e. the topicalized (or focalized) PP *s afto*²¹.

In the light of these remarks and the above structure underlying 130 (and 131), we can consider some cases of coordination involving RCs with PPs of the type under discussion; cf.:

135. To aftokinito pu m afto piye sti Thesaloniki
 the car. that with this went-3rd s. to-the Thesaloniki
 ky ekane ti listia tis trapezas itan klemeno
 and made the robbery (of)-the bank was stolen
 The car by which he went to Thessaloniki and
 robbed the bank was stolen

136. Afto ine to makheri pu ekopse to kreas ke
 this is the knife that cut-3rd s. the meat and
 m afto skotose istera ta pedhya tu
 with this killed-3rd s. then the children (of)-his
 This is the knife he cut the meat with and then
 he killed his children

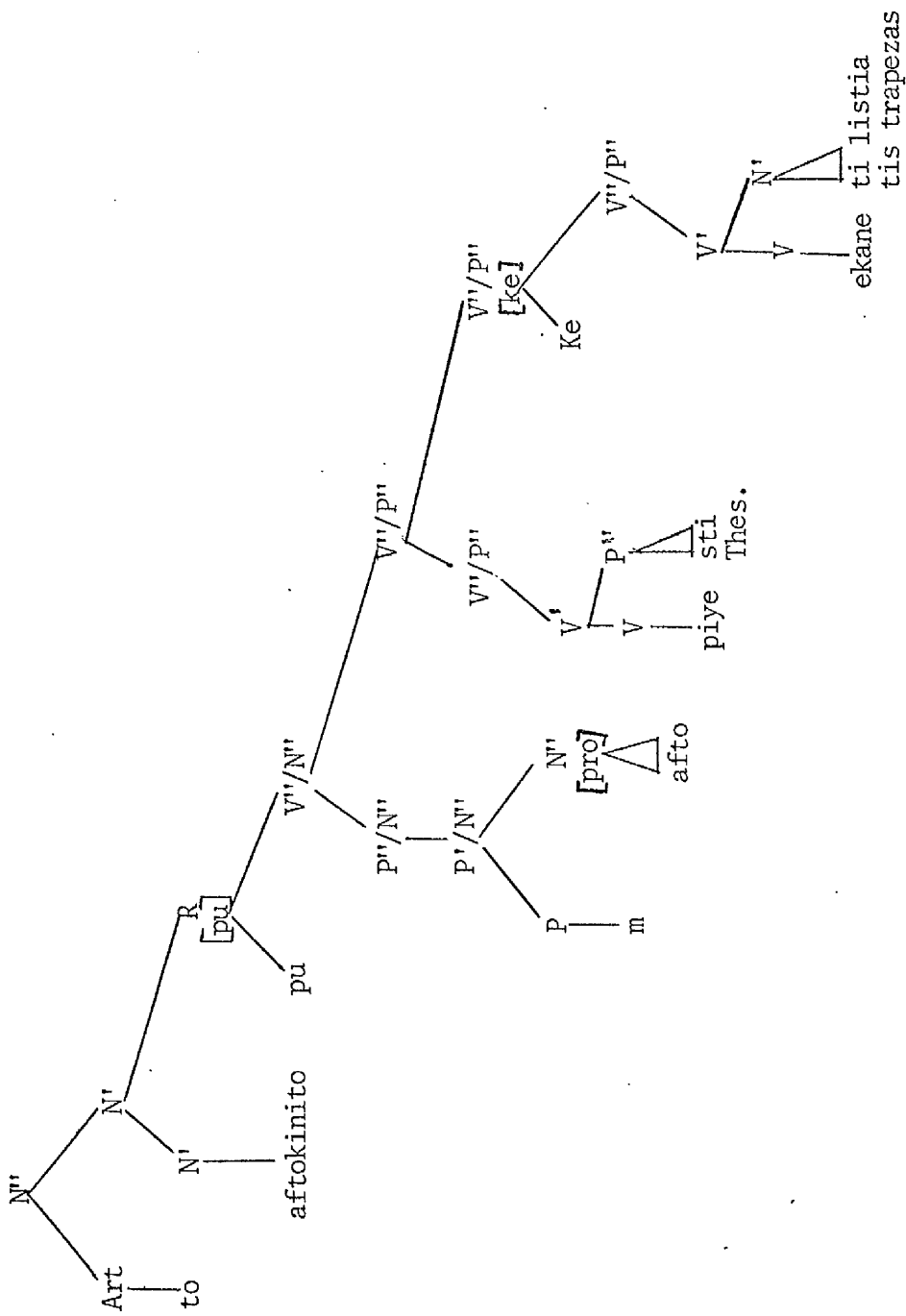

The structure of 136, on the other hand, is:

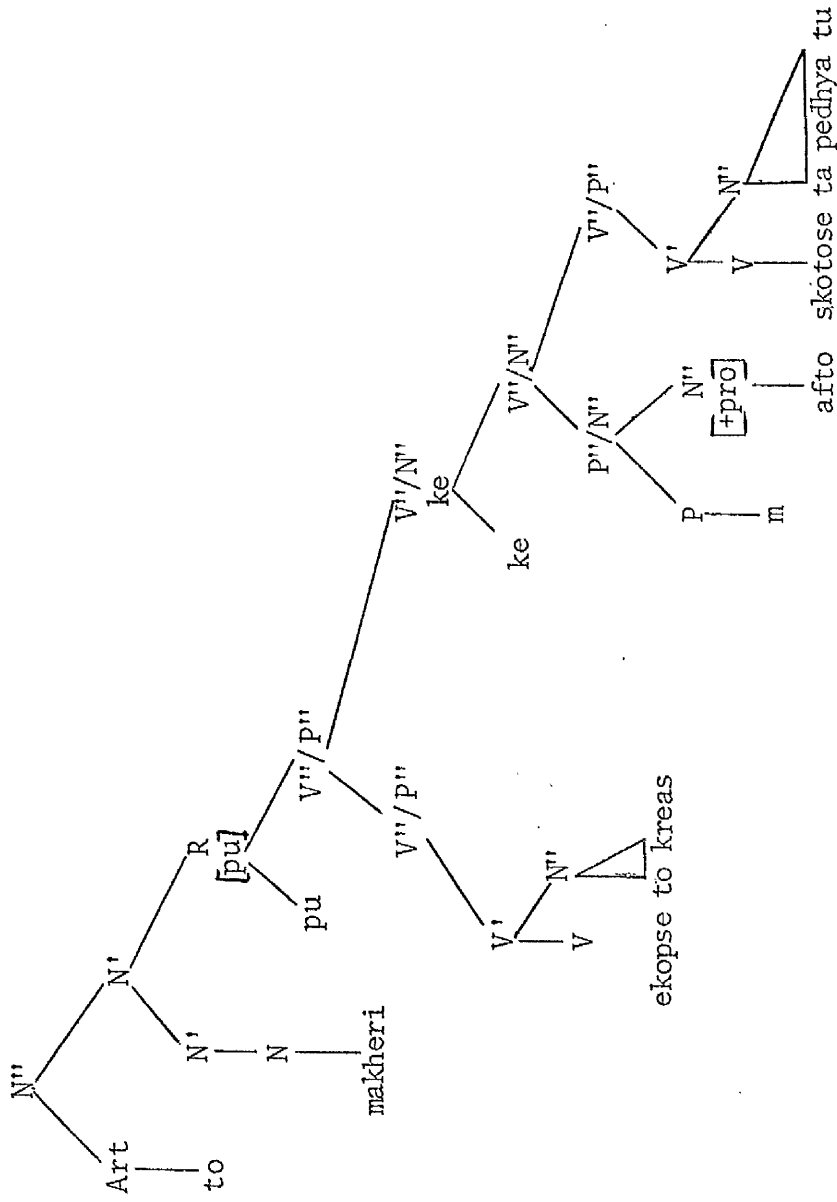

This second structure combines - in a way - elements of the structure underlying 135 (the V"/N" node) and elements of the structure underlying 130 (the V"/N" and V"/P" nodes). In the case of 135, no problem arises with regard to coordination - there are two V"/P" nodes conjoined. The single V"/N" is above *both* of these V"/P" nodes. The P" *me afto* is topicalized in both conjuncts, as the V"/P" nodes suggest. But the situation in 136 is more difficult; here, as the relevant structure stands, a V"/P" node is conjoined to a V"/N" one (we should notice, parenthetically, that the V"/P" node accounting for the 'fronted' P" blocks strings like 137 and 138:

137. *...pu m afto ekopse me to makheri to kreas

138. *...pu skotose m afto me to makheri ta
pedhya tu).

Consequently, the result ought to be bad but it is not. I suggest that the grammaticality of examples like 136 be explained in terms of the common feature of N and P-[-V]- (see p. 19). Thus, the categories that are conjoined in 136 are both V"/[-V]". In the same connection we shall now cite examples, in which the need for the 'feature' approach to some cases of coordination appears to be independently motivated, therefore further justified.

139. ...to makheri pu vrike k ekopse to psomi...
the knife that found-3rd s. and cut-3rd s. the bread...
The knife he found and cut the bread with...

140. O anthropospu me voithise ke sinerghazome...
the man that me helped-3rd s. and collaborate-I
khronya...
years...
The man that helped me and with whom I collaborate for a long time...

141. I eklisia pu ine konda mas ke piyeno sikhna...
the church that is close us(clit) and go-I often...
The church which is close to us and to which I go often...

In 139-141 what we get is a RC with an object or subject dependency (i.e. of V"/N" type) conjoined to a RC with a PP dependency (i.e. of V"/P" type). We cannot account for such cases unless we use the common feature(s) of the categories on the right of the slash. In the light of these examples we can collapse rules 97, 101 and 134 as in rule 142:

142. R [pu V"/ [-V]"]
 [-wh]

[-V]" stands for both N" and P", so rule 142 accounts for RCs with subject, object and 'prepositional' dependencies.

3.7.3 'Complex' Adverb Phrases and pu-relatives

Apart from simple PPs, we must also consider *pu*-relatives with so-called 'complex adverbs' (or 'prepositions') of the type illustrated in corresponding WH-relatives (see p. 292). The following examples show such *pu*-relatives:

- 143.a. To trapezi pu *brosta s afto* evala ti dileorasi...
 the table that in front to this put-I the TV...
 b. To trapezi pu *s afto brosta* evala ti dileorasi...
 the table that to this in-front put-I the TV...
 c. To trapezi pu evala *brosta s afto* ti dileorasi...
 the table that put-I in-front to this the TV...

- d. To trapezi pu evala *s afto brosta* ti dileorasi...
the table that put-I to this in front the TV ...
- e. To trapezi pu *brosta tu* evala ti dileorasi...
the table that in front-it(clit) put-I the TV...
- f. To trapezi pu evala *brosta tu* ti dileorasi...
the table that put-I in front-it(clit) the TV...
- g. To trapezi pu *brosta* evala ti dileorasi...
the table that in front put-I the TV...
- h. To trapezi pu evala *brosta* ti dileorasi...
the table that put-I in front the TV...
The table in front of which I put the TV...

In a and b we have the topicalized version of c and d (cf. note 22), in which the whole Adv" has been moved from within the VP to a position in front of it. In b and d it appears that we have another - 'local' - topicalization by which the P" is placed in front of its governing Adv". This is again reminiscent of the alternations exemplified on page 295-296. This is independent of the topicalization of the whole Adv". In g and h the whole P" has been omitted, so it seems that we have a P" dependency into Adv. In e and f we obtain a sequence consisting of an adverb followed by a clitic pronoun. That this pronoun is rather the 'reduced' form of a PP is certain, since adverbs - as already said - are not followed by a (pro)noun in the accusative (cf. **pano to trapezi/*pano afto*), but are followed by a PP often reduced to a clitic. Such strings exist independently of RC formation or unbounded dependency (cf. p.298), e.g.:

.144.a. Konda sto limani
 {tu }
 close to-the port
 {it(clit.) }

- b. Makria {apo ton andra tis}
 tu
 away {from the husband (of)-hers}
 him(clit.)

To account for examples like 143e,f we shall employ again the slash elimination metarule II, in order to get the (clitic) pronoun in the position of an N'' gap. As suggested by 144a-b, the feature [+clit] under N'' on the right of the slash is necessary again (cf. p. 338). Furthermore, the feature [+gen] will guarantee that this clitic will be in the required case. Accordingly, the relevant metarule will be written as:

$$\text{Adv}' \rightarrow \text{Adv}, \begin{matrix} \text{N}'' \\ [+pro] \\ [+clit] \\ [+gen] \end{matrix} \Rightarrow \text{Adv}' / \text{N}'' \rightarrow \text{Adv}, \begin{matrix} \text{N}'' \\ [+clit] \\ [+gen] \end{matrix} \begin{matrix} [+pro] \\ [+clit] \\ [+gen] \end{matrix}$$

Thus we see that W in the general rule schema of page 31 stands for Adv, too. For examples 143a-d we have already a rule giving pronominal dependencies into P (see p.338) - whether the PP is in V' or Adv' is irrelevant. Finally, examples g and h exhibit a PP dependency - here the whole PP is missing. This is an 'odd' case, for what we get in fact is a 'gap' directly governed not by V, as slash elimination metarule I requires, but by Adv (or by P if one labels the whole phrase as P'' - i.e. considers the governing node as P''). But according to the slash elimination metarule II dependencies into Adv end as pronouns. So, neither of our two slash elimination metarules captures examples like 143g-h. One way to handle these cases without abandoning the two well-justified SEMs is consider *pu* here as an adverb (*opu*, 'where', see p. 349), so that *pu konda* parallels *edho/eki konda* etc. In such a case we shall have a *wh*-relative (*pu*=

opu) with pied piping (cf. 2.4.1). However, this solution requires further motivation with respect to the equation of *pu* with *opu*, and I leave the question open.

3.7.4 Summary

Closing our syntactic account of *pu*-relatives with a simple PP dependency or with a 'complex' AdvP (dominating a PP) dependency, we can summarize the basic points of our discussion as follows: we observe an omission of the whole PP when governed by V, a case captured by SEM I; we can also have an omitted PP immediately dominated by Adv'. This case cannot be accounted for by the two SEMs, therefore I propose instead that *pu* here be considered as the *wh*-adverbial *opu*, pied-piping - obligatorily - a non-*wh*-adverb. It should be stressed that *pu* gets this adverbial reading very often in relative clauses (cf. 3.8 below). Furthermore, there are NP dependencies into Adv' and P'. These are accounted for by SEM II, written appropriately in each case, so as to give us the pronouns required. Thus, the NP dependency in P' results into a full pronoun, whereas the same dependency in Adv' results into a clitic pronoun. Consequently, W in the general rule scheme of page 31 stands for N,P,Adv (we shall see that it stands for Adjective too). What must be pointed out here is that, as already mentioned earlier, SEM II - the metarule giving pronouns instead of 'gaps' - simply utilises constructions independently required in the grammar. For example, the right-hand side of both parts of the metarule of page 345 is a string existing in the language independently of unbounded dependency, as shown by example 144a-b. Now, the alternation between the two forms of 144a-b

- namely between a PP and a clitic pronoun when both are governed by Adv - must be accounted for by a metarule, too; but since such a metarule has nothing to do with RC formation, it does not concern us here. We are now in a position to explain the fact that preposition stranding is never observed in MG. Pied-piping is obligatory in *wh*-relatives and this is ensured by the requirement that the foot feature *wh* ascend onto the maximal containing category, whereas in *pu*-relatives no *wh* feature is present and the dependency can go further down into complements of $V^{(n)}$. Besides, there is a requirement that only *V* can govern gaps (SEM I). Dependencies into categories other than *V* result into pronouns (SEM II); thus it is only in *pu*-relatives that we find pronouns instead of gaps. Finally, *pu* being a complementizer (cf. 3.1) and not a pronoun cannot pied-pipe any material.

3.8 The omission of the PP in *pu*-relative clauses

Having dealt with the syntax of *pu*-relatives, we can consider briefly the issue of the omission of the PP from *pu*-relatives. Very often the omitted prepositional phrase can be 'recovered' (we should recall here that *pu* does not carry by itself any element for the recovery of the PP: it is uninflected, not having any gender, person, case characteristic), as Theophanopoulou points out, either uniquely or ambiguously. What contributes to the unique recovery is the 'lexical features' of the constituents involved (for example in the case of *to trapezi pu evala to vivlio* or *i skupa pu skupisa to spiti*, the 'pragmatic' relationship between the head and the verb of the RC is self-evident: we put the book on the table and we clean the house with a broom.),

as well as certain elements that make clearer the function of *pu*, such as preverbal affixes (cf. *sinerghazome me* - the affix *sin* corresponds to the preposition *me* -, *apokhoro apo* etc.), adverbs, change of person (e.g. *i kopela pu khorevame*). On the other hand, the 'elliptical' or 'marginal' (i.e. not very common) use of certain prepositions is a negative factor for the correct establishment of the relationship between the head and the RC (e.g. *meno me ti thia mu*/**i thia mu pu meno*). We get an ambiguous 'recovery' of the PP either when it is not a strictly subcategorized argument of the verb, or if a verb can subcategorize more than one prepositional phrases (e.g. *yemizo me/apo, ftano se/os/mekhri*). In ambiguous recovery of the PP, what makes a preposition prevail over another is mainly its meaning, or, rather its use; for example, the general and unmarked prevails over the marked one; so, in the case of a P denoting place or direction the P *se* is the more general, hence the most easily 'recoverable'. The above remarks as presented by Theophanopoulou are certainly true. What is important, however, is examine the exact position(s) of the PP within the whole structural configuration. As Theophanopoulou underlines, the level in which the omitted PP originates is the first necessary - though not sufficient - factor for the 'recovery' of the PP. Is this a VP or a V complement? A first easy distinction to be drawn is that between PPs that have a genuine adverbial function (V'' or V' complements) and PPs that are arguments subcategorized by V. In the latter case these are equivalent to case-marking - i.e. they correspond to a dative (for a justification of the distinction between case-markers and PPs as distinct syntactic categories cf. also Jackendoff 1977, section 4). Now, indirect objects

are just a subclass - or a special class - of functional arguments, since verbs subcategorize for other PPs as well (cf. *exartome apo, simfono me* etc.).

But what is meant exactly by PPs with 'adverbial' function ? Here, another distinction is obvious with respect to MG. There are PPs genuinely - as it were - adverbial (i.e. with reference to place or time). These can always be omitted in *pu*-relatives (and are almost required to be omitted) unconditionally. This must be related to the historical derivation of *pu*, coming from the relative(local)adverb *opu*. And this has certainly a bearing on Theophanopoulou's claim that in ambiguous 'recovery' of an omitted PP the general and unmarked 'reading' prevails over the marked one, thus, it is the P *se* that is always understood in cases of denotation of place (*pu* here is equivalent to the adverb *opu*), cf.: *to meros pu pigha - to meros opu pigha - to meros sto opio pigha* (the place where/to which I went). Such purely adverbial PPs must be considered as complements of V'. On the other hand, there are PPs which again belong to V' but are not adverbial in the sense shown above. These are so-called 'VP (V') adverbials' that "usually express manner, means, accompaniment, instrument, purpose" (Jackendoff 1977:61). To summarize so far, we have distinguished the following types of PPs that participate in *pu*-relative clause formation: (a) indirect objects PPs, (b) functional arguments of V, other than IO (OBL of K.@ C.'s), (c) purely adverbial PPs - complements of V', (d) so-called 'adverbial' PPs of manner etc. - complements also of V'. (b), (c), (d) can certainly be omitted in *pu*-relatives. What about (a) ? To give an answer to this question we shall first refer to the feature [+m] / [-m] introduced by Horrocks and Gazdar

(1981). This feature distinguishes those PPs that correspond to an indirect object and those PPs classified as (b) and (d) above. Thus, in the latter case the preposition chosen is crucial, since the meaning of the entire PP is "precisely determined by that preposition" (Horrocks @ Gazdar 1981:7), whereas in the former the preposition has "no independent meaning in the context" (ibid.), thus, the PP corresponding to indirect objects involves always the *P se*. We must note here that the feature [$\pm m$] by which PPs equivalent to indirect objects are marked as [-major] and PPs such as (b) and (d) are [+major], is a feature of entire PPs, not of prepositions. Horrocks and Gazdar claim that the feature [+m] is a necessary (but not sufficient) requirement on the PP which is omitted in *pu*-relatives. In effect, we get dependencies in *pu*-relatives of PPs that have an 'adverbial' function²² (of course, not any PP [+m] can be omitted; it can be so only if it is 'recoverable', and its recoverability depends on several factors as said above). To repeat the question that arises with respect to this [$\pm m$] feature, is it only [+m] PPs that can be omitted in *pu*-relatives? As it appears, PPs [-m] - i.e. PPs corresponding to indirect objects can also be omitted; cf.:

145. I mathitria pu edhosa ti ghramatiki mu
the student that gave-I the grammar (book) (of)-mine

With regard to this type of examples, Horrocks and Gazdar claim that the explanation of the existing 'gap' in terms of an omitted PP is incorrect, since in Greek "indirect objects can also appear preverbally as genitive NPs directly dominated by VP" (H. @ G. 1981:12). So, in 145 what has been omitted is an N" [+gen] rather than

a PP (cf. 3.5). However, there is nothing to prevent us from considering that the missing material in 145 is a PP [-m] and not exclusively an NP [+gen]. If this is indeed so, then we can conclude that all (a)-(d) 'types' of PPs can be omitted, in principle, from *pu*-relatives. The fact that this is not always the case is due, as already stressed, to performance factors determining which PP exactly can be omitted in every case.

3.9 Clitics in *pu*-RCs and the 'Accessibility Hierarchy'

If all the foregoing is basically correct, we are in a position to make some general remarks with regard to the constituent which is relativized, the omission or retention of the (clitic) pronoun and the Accessibility Hierarchy of Keenan and Comrie's. We have seen that the clitic pronoun is never present in direct object restrictive relatives. In appositives it is optional. But in restrictive relatives with an indirect object dependency things begin to be quite different. The pronoun here is optional, its presence no longer marking the distinction between restrictives and appositives. As we go further down on the hierarchy we see that the pronoun becomes indispensable in the position relativized. Thus, in the case of relativized NPs called 'OBL' (subcategorized arguments, other than indirect objects) the pronoun is always present. Coming next to relativized (possessive) genitive NPs - of the sort *o kirios pu o pateras tu erg hazete....*-, we saw that the genitive clitic is always required - its omission yielding an ungrammatical string. And exactly the same obtains of relativized objects of comparatives, realized again as a clitic in the genitive case; cf.:

146. O mathitis pu ime kaliteros tu...
the student that am-I better him (clit)...
The student than whom I am better...
147. I fili mu pu ime plusioteri tis...
the friend(of)-mine that am-I richer her(clit.)...
My friend than whom I am richer...

The obligatory presence of the clitic here - existing in comparatives constructions independently of RC formation (cf. *ime kaliteros tu*) - is accounted for by the slash elimination metarule II written as

$$\begin{array}{c}
 A' \rightarrow A \\
 [+comp] \quad [+comp]
 \end{array},
 \begin{array}{c}
 N'' \\
 [+gen] \\
 [+pro] \\
 [+clit]
 \end{array}
 \Rightarrow
 \begin{array}{c}
 A' / N'' \\
 [+comp]
 \end{array}
 \rightarrow
 \begin{array}{c}
 A \\
 [+comp]
 \end{array},
 \begin{array}{c}
 N'' \\
 [+pro] \\
 [+clit] \\
 [+gen]
 \end{array}$$

'Adjective' completes the set of values that W can have in the general rule schema in the Introduction (p. 31). Given the distribution of clitics in N, Adv, A, we can collapse the relevant slash elimination metarules into

$$\alpha \rightarrow W, \begin{array}{c} \beta \\ [+pro] \\ [+clit] \\ [+gen] \end{array} \Rightarrow \alpha / \beta \rightarrow W, \begin{array}{c} \beta \\ [+pro] \\ [+clit] \\ [+gen] \end{array}$$

W = N, A, Adv

The reason why P cannot be included in the values of W here is that β after P is never a clitic but a full pronoun. However, since there is independent principle that explains the distribution of clitics (cf. pp.298,338), P may also be included, in which case the above metarule would be redundant, given the general SEM II on page 31. These facts, as presented above, lend some support to the claims made by K. @ C. concerning the relativizeability of the NPs that belong to the positions shown on the AH scale

(p. 326). Thus, it appears to be true that languages tend to show a tendency to use pronoun retaining RC-forming strategies. And what is more important, once a language begins to retain pronouns, it will do so for so long as relativization is possible at all. This is a natural consequence of the assumption that pronoun retaining strategies are used in proportion to the difficulty of the position being relativized, although the point of difficulty differs from one language to another (cf. K. & C. 1977). This last statement follows from the general assumption that the "AH" directly reflects the psychological ease of comprehension. The lower a position is on the AH the harder it is to understand RCs formed on that position..." (K. & C. 1977:88). "It would be natural that a way of relativizing a certain position might not be applicable at the next lower position, on the general assumption that syntactic processes are ways of encoding meanings, and if one meaning is inherently more difficult to encode than a strategy for encoding the first need not apply to the second" (ibid.). According to this assumption, the presence of the pronoun in the lower positions of the AH scale is explained in terms of the fact that a pronoun retaining language "presents in surface structure more of the logical structure of the RC than do languages that do not present such pronouns. The reason is that in the pronoun-retaining strategy the restricting clause in surface is a sentence - one that expresses exactly the restricting sentence of logical structure" (ibid. p. 92).

Along these lines we get a theoretical explanation for the pronoun retention observed in all the relativized positions after that of (direct) object. We have pointed out the gradually increased necessity of the pronoun, optional in IO, never omitted in OBL, becoming indispensable in GEN and OCOMP - the two last

positions on the AH scale.

Incidentally, it is worth noticing that in *pu*-relatives all the positions are relativized, due to the appearance of the (clitic) pronoun accounted for by the slash elimination metarule II. In *wh*-relatives the object of comparison, the OBL and the indirect object are 'conflated' - in other words they are all treated as ordinary PPs as far as relativization is concerned.

4. The structural position of restrictives and appositives

In the preceding section we examined the internal structure of restrictive relatives. The structure of appositives is not radically different - the basic difference is the presence of the object clitic pronoun in non-restrictives. But it is exactly this difference that is crucial for the attachment of appositives at a different level than that of restrictives, as we shall see below.

4.1 The structural position of restrictives and appositives in Jackendoff's Grammar

Jackendoff (1977) shows convincingly that restrictive relatives, being restrictive modifiers, are complements of N' (in his three-bar system). The alleged advantage of the favourite determiner theory (in which the RC originates as a constituent of the determiner) is shown to be groundless compared to the NP-complement theory, which allows for the generalization that all restrictive modifiers are daughters of (Jackendoff's)N''; thus, it is

shown that APs, PPs and restrictive relatives "can all be interpreted as restrictive modifiers, by whatever projection rules happen to apply to them" (Jack. 1977: 179), since they satisfy the constraint on the appearance of the definite article, and the constraints show that restrictives in nearly all aspects behave just like other daughters of N'' (ibid.p.89). Following his main arguments²³, I also assume that restrictives are complements of N' , in my two-bar system, since they behave like PPs or NPs which are also complements of N' (cf. pp.149-150). The relevant structure is the following:

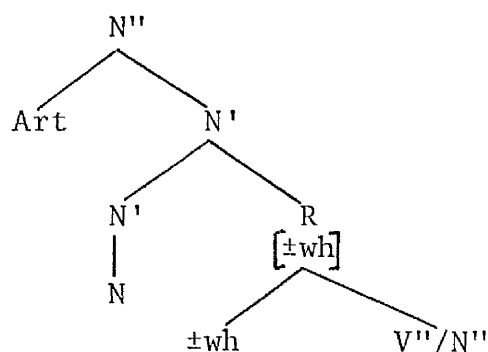

We should recall here that N' is a recursive node (see p. 124) and that restrictive modifiers appear as daughters of N' and, at the same time, as sisters of N' . The LP rule $H' < \alpha < R$ accounts for the fact that restrictive relatives come always last in a series of complements of N' .

4.2 The position of appositives

The appearance of the resumptive pronoun in direct object dependency relatives (cf. 1.2.1) indicates that such relatives refer back to the *whole* preceding NP (i.e. to the sequence

Art +N). In this respect Modern Greek provides more (and crucial) evidence for the attachment of non-restrictives at the maximal projection of X (in X'' in my framework). Cf. also "...there are several reasons for supposing that nonrestrictive relatives are, rather, complements of the full NP (and in some cases, of a full sentence-)..." (Chomsky, 1965:217, note 26). The relevant configuration will, then, be:

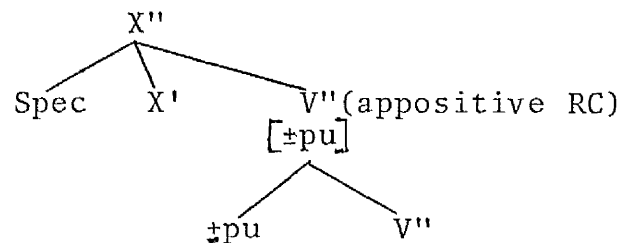

The following remarks are in order here; first X'' stands here for all the major categories, N'',V'',A'',P'', since we saw in 1.2 that appositives can modify any category, i.e. they follow N'',V'',A'',P'', and that this is one basic property that distinguishes them from restrictive relatives. Second, the appearance of the resumptive pronoun - consequently the non-existence of a 'gap' - suggests that we are dealing with full sentences and that we need not distinguish them formally from other sentences; in effect, V'' for appositives will be distinguished from the other sentential categories by the addition of the appropriate features $\begin{bmatrix} +R \\ \pm pu \end{bmatrix}$ under it (cf. the list of sentential categories on p. 285). Then, we keep R for restrictives with a 'gap', with the appropriate feature indicating *wh*- or non-*wh*-restrictives.

Needless to say, the order of a restrictive and an appositive as shown in 2.2 (p. 264) - the appositive strictly following the restrictive - is captured if we

make restrictives a complement in N' and appositives a complement in N" (cf. "the fact that appositives always follow restrictives is explained by the NP-complement theory as a consequence of restrictives being N" complements and appositives being N'" complements" (Jack. 1977: 172).

Finally, the difference in intonation between restrictives and appositives (cf. p.263-4) is also explained in terms of appositives being 'higher' than restrictives; cf.: "the differences in intonation between restrictives and appositives argue rather strongly that the two kinds of clauses have different syntactic sources..." (Jack. 1977:172). Furthermore, "the comma intonation before appositives is characteristic of all X'" "(in this theory X"), "complements, since sentence-final-sentence adverbs, parentheticals, and the like have similar intonation" (ibid.).

4.3 Summary

In this sub-chapter we have examined the internal structure of restrictive relative clauses. We proposed rules for *wh*-relatives and *pu*-relatives with subject, object and prepositional phrase dependencies, and we used two slash elimination metarules to account for the 'gap' in each case; in the first of these we 'eliminated' the N"/N" or P"/P" category by getting a 'gap'. By the second metarule we got a (full or clitic - depending on the governing category-)pronoun instead of a 'gap'. This enabled us to account for the occurrence of the pronoun in certain *pu*-relatives. It also enabled us to treat 'gaps' and pronouns in these relatives as the same, and thus explain certain cases of coordination.

Finally, we claimed that restrictive relatives are complements *in* N', whereas appositives must be attached under N". This placing of RCs accounts for their actual ordering - appositives always following restrictives. In the following sub-chapter we shall briefly consider Nominal ('Free') Relatives in order to further justify the two SEMs and our remarks on the relativizeability of NPs according to their position on the AH scale.

B. 'FREE' (NOMINAL) RELATIVES
(An analysis)

1. General remarks

As was mentioned in the introduction of the RC chapter, a distinction is drawn by traditional Greek grammars between 'adjectival' ('epithetikes') and 'substantival' (or 'nominal'- 'usiastikes') clauses. It is stressed that all adjectival clauses are relative clauses, but the reverse statement does not hold. To be more precise, a relative clause that plays the role of a noun phrase - i.e. one that replaces a major constituent of a sentence, like a subject, an object etc. - is given the name of 'substantival' ('nominal') RC.

The following examples illustrate this:

1. *Opyos to ipe afto na erthi edho*
who(ever) it(clit) said-3rd s. this to come here
The one who said that may come here
2. *Rotuse opyon sinanduse*
asked-3rd s. whom(ever) met-3rd s.
He asked whomever he met
3. *Ghrapse o,ti thelis*
write whatever want-2nd s.
Write whatever you want
4. *Tha aghoraso osa mu ipes*
will buy-I what me(clit) said-2nd s.
I will buy those (the things) you told me
5. *Aftos ine o,ti dhe fandazese*
he is what not imagine-2nd s.
He is what you cannot imagine

In 1 the underlined RC functions as the subject

of the whole sentence; in 2,3 and 4 as the object, and in 5 it functions as a predicate phrase. In contrast, the function of the RCs we have already considered is that of modification or classification, i.e. 'adjectival' relatives *modify*, as restrictive modifiers, some major constituent of the sentence (subject, object...) - hence their name 'adjectival'; let us recall that adjectives are the restrictive modifiers 'par excellence'.

It is crucial to note that these two subdivisions of RCs are introduced by different pronouns (or 'relativizers'). Thus we notice the characteristic difference between the pronoun *o opios*, which introduces always an 'adjectival' relative, and the pronoun *opyos*, which introduces exclusively a nominal RC, parallel to the pronouns *osos* (how much (many), as much (many)), *oti* (what, whatever). Along these lines, we must point out that the existence of this set of pronouns suggests that 'nominal' RCs must be considered independent of interrogative clauses (embedded constituent questions, cf. p. 285), which are 'introduced' by an entirely different set of pronouns. Let us consider the following table of 'correlative' pronouns:

| <u>Interrogative Pro.</u> | ↔ | <u>Demonstrative Pro.</u> | ↔ | <u>('Free') Relative Pro.</u> |
|---|--------|---|--------|--|
| { pyos ? ti ? } posos ? ti idhos ? (of (what kind)) | ←————→ | { aftos-ekinos afto-ekino } tosos tetyos | ←————→ | { opyos o,ti } osos opyozdhipote otidhipote (see below) |

2. The nominal character of 'nominal' relative clauses

The clear-cut distinction between interrogative and nominal ('Free') relatives is drawn systematically by Br. @ Gr. (1978). In the same connection, we can emphasize the fact that the pronouns of the last column introduce only clauses whose distribution matches that of simple noun phrases (see below), whereas interrogative pronouns introduce only questions (both root and embedded ones) with a distinct distribution; cf.:

6. Na erthun { *i mathitries*
to come-3rd pl. { the students (fem.)
 { *opyi ekhun sira*
 { who(pl.) have-3rd pl. turn }
 { **pyi ekhun sira*
 { who? have-3rd pl. turn? }
- Let come { the students
 { the ones coming next
 { *who? come next }
7. Tha aghoraso { *osa vivlia boro*
shall buy-I { as many books can-I
 { *dheka vivlia*
 { ten books
 { **posa vivlia*
 { how-many? books }
- I shall buy { ten books
 { as many books as I can
 { *how many? books }

We can clearly see the equivalence in distribution between the simple phrases and the clause introduced by *opyos/osos* - both underlined - in 6-7 above. We also

see that the substitution of the interrogative pronoun for the corresponding relative one yields an ungrammatical string.

Finally, another essential difference between interrogative and relative pronouns lies in the fact that the suffix *-dhipote*, corresponding to the English *-ever*, can be attached *only* to relative pronouns to form: *osozdhipote*, *opyozdhipote*, *o,tidhipote*²⁴. The choice between a 'bare' relative pronoun and a pronoun suffixed by *-dhipote* is determined rather by semantic factors, which will not concern us here.²⁵

2.1 Nominal relatives as 'free' relatives

'Nominal' relative clauses must be seen as just one instance (case) of what have come to be called 'Free Relatives' within TG. 'Free' relatives are shown in the following examples:

8. I'll buy what he is selling
9. John will be however tall his father is
10. I'll word my letter however you word yours

The underlined phrases are called 'free' because they have been considered as 'headless' - i.e. as having no antecedent - unlike 'ordinary' (modifying) RCs. In 8 the underlined relative performs the function of an NP, in 9 of an AP and in 10 of an adverb phrase. However, in a very illuminating article, Bresnan and Grimshaw show convincingly that in fact, 'Free' relatives are *headed*, "the *wh*-phrase occupying the position of the head of the clause" (Br. @ Gr. 1978:337). Schematically, 'free' relatives originate in a configuration like

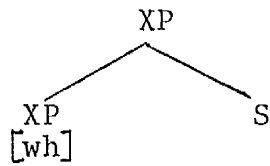

26

I shall basically assume this treatment of FRs throughout my analysis, without further justifying it. This same treatment of FRs was adopted and further elaborated by Gazdar (1980), and presented in the following general rule-schema:

$$11. \left[\begin{array}{c} \alpha \\ \alpha \quad [\text{wh}] \end{array} V''/\alpha \right], \text{ where } \alpha = X''$$

and X'' stands for all major categories (cf. Gazdar 1980: 63). I shall concentrate here on 'nominal' free relatives, i.e. on relatives that function as NPs within a sentence, using the name 'free' or 'nominal' invariably throughout my analysis. As a first modification of rule 11, I shall introduce the feature [+FR] indicating the type of *wh*-word associated with Free relatives (cf. p. 286). We can, then, list the set of items that belong to [WH FR] - i.e. *o, ti, opyos* etc.

2.2 Further evidence for the nominal status of 'free' relatives

The nominal distribution of the 'free' relatives we shall be considering is further shown by the following examples:

- 12.a. *Osa kerdhizi ta pini*
as many earns-3rd s. them (clit.) drinks-3rd s.
- b. *Ta pini osa kerdhizi*
them(clit.)drinks-3rd s. as many earns-3rd s.
He drinks what he earns

The presence of the clitic pronoun in 12a-b, due to the rule of 'clitic doubling', is a clear evidence that the clause it 'doubles' is an NP. Just as ordinary NPs can be topicalized or focalized, so can 'nominal' clauses. Thus, the topicalized NP in 12a-b requires the resumptive pronoun, whereas the focalized 13a-b excludes it; cf.:

- 13.a. *Osa kerdhizi (*ta) pini*
b. *(*Ta) pini osa kerdhizi*

We further notice that the whole nominal clause agrees in all its features (gender, case, number) with the clitic pronoun, as the *wh*-pronoun clearly shows - the 'head' of the whole clause according to the theory adopted here (*osa-ta*).

Nominal clauses have all the syntactic functions of simple NPs, as expected. Thus, they can be complements of nouns; in the following example the 'free' relative is a restrictive modifier:

14. *Paratheti katalogho (ton) oson evasilepsan*
cites-3rd s. list ((of)-the) who reigned-3rd pl.
He cites a list with the names of those who
had reigned

The underlined clause is a genitival complement. But example 14 exhibits another interesting consequence of the claim that 'nominal' relatives are in fact NPs: this is the - optional - presence of the definite article, agreeing always with the head noun according to the CAP (cf. p. 21). The presence of the definite article is a property of all the clauses that have the distribution of a noun (so-called 'nominal', in general)

in MG, including those introduced by the complementizers *oti*, *pos*.

3. A syntactic analysis of nominal relative clauses

In what follows I shall propose rules to account for the distribution and internal structure of nominal relative clauses. We shall show that the general slash elimination metarules we used for dependencies in adjectival RCs are valid for these relatives too, and that the remarks we made according to the Accessibility Hierarchy, with regard to the position relativized in adjectival relatives, apply with complete generality here as well. What is even more interesting in the case of 'nominal' free relatives is the phenomenon of 'attraction' connected with them. This will be fully explained and accounted for by our analysis.

3.1 Nominal relatives in argument positions

We shall start with examining what happens when the nominal relative is an 'argument' of the 'matrix' - the governing-verb.

The following examples are instances of the nominal clause being the *subject* of the matrix verb:

15. Irthan osi ithelan
came-3rd pl. who wanted-3rd pl.
Those who wanted to come came

16. Irthan osi ghnoriza
came-3rd pl. who knew-I
Those I knew came .
- 17.a.*Irthan se osus ikha embistosini
came-3rd pl. to whom had-I confidence
b.*?Irthan osi ikha embistosini
came-3rd pl. who had-I confidence
c. Irthan osi tus ikha embistosini
came-3rd pl. who them(clit.) had-I confidence
Those I trusted came .
- 18.a.*Khalase s opyo trapezi akubises ti dileorasi
was damaged to what table put-2nd s. the TV
b. Khalase opyo trapezi akubises ti dileorasi
was damaged what table put-2nd s. the TV
Every table you put the TV on was damaged
- 19.a.*Irthan {oson } o Yanis ine meghaliteros
 {apo osus }
came-3rd pl. {who(gen.) } the John is older
 {than whom }
- b.*Irthan osi o Yanis ine meghaliteros
came-3rd pl. who the John is older
c. Irthan osi o Yanis ine meghaliteros tus
came-3rd pl. who the John is older them (clit.gen.)
The ones who are younger than John came
- 20.a.*Irthan oson akustike to onoma
came-3rd pl. whose was-heard the name
b.*Irthan osi akustike to onoma
came-3rd pl. who was-heard the name
c. Irthan osi akustike to onoma tus
came 3rd-pl. who was-heard the name (of)-them (clit.gen.)
Those whose name was heard came

Throughout examples 15-20 the relative pronoun (*osos/opyos*) has a range of syntactic functions with regard to its own - i.e. the subordinate-verb. These functions are that of subject, direct object, indirect object, locative complement, object of comparison, possessive genitive. We get similar examples when the nominal clause is the object of the main verb; for simplicity reasons I do not cite such examples.

Let us first explain the ungrammaticality of some of the starred examples above. 17a, 18a, 19a and 20a are bad because the relative clause (as an NP) does not comply with the subcategorization requirements of the matrix verb; e.g. in 17a it should be the subject of the verb *irthan*, but in fact it is governed by a preposition, i.e. it is a PP and subjects are never PPs. On the other hand, in 17b, 19b, 20b the subcategorization requirements of the matrix verb are met by the relative clause, which is in subject position, (in both, the syntactic category of the RC *and* the *case* of the 'head' pronoun), but now it is the subcategorization requirements of the subordinate verb that are not met by the relative pronoun. For example, in 17b *osi* is in the nominative case, as required by the main verb *irthan*, but this case contradicts the function of the pronoun with respect to its own verb, *ikha embistosini*, requiring an object in the dative case (a PP [+se]). These facts strongly suggest that for this sort of sentences to be grammatical there must be a 'compromise' between the two functions of the relative pronoun: its function with respect to the matrix verb and its function with respect to its own - the subordinate-verb. How is, then, this 'compromise' accomplished, or, what are the consequences of it? In other words, which are the

rules generating the grammatical strings of 15-20 above ?

For the cases where no 'conflict' is observed between the two functions of the pronoun, no problem arises. This is the case of 15 as well as of 21 below:

21. Aghapo osus aghapas ky esi
 love-I who(pl.) love-2nd s. and you
 I love those you love

Accordingly, rule 11 can be written as follows, in order to account for simple cases of subject/direct object dependency nominal relatives:

22.
$$\begin{matrix} & [N'' & & V''/N''] \\ N'' & [WH & FR] & \end{matrix}$$

The appropriate case-marking under the two instances of N'' will account for subject and direct object relatives. This marking is taken care of by the HFC, since, within our framework, N'' [WH FR] is the head. The slash elimination metarule I will give the gaps at the appropriate position in each case. Let us see the following diagrams:

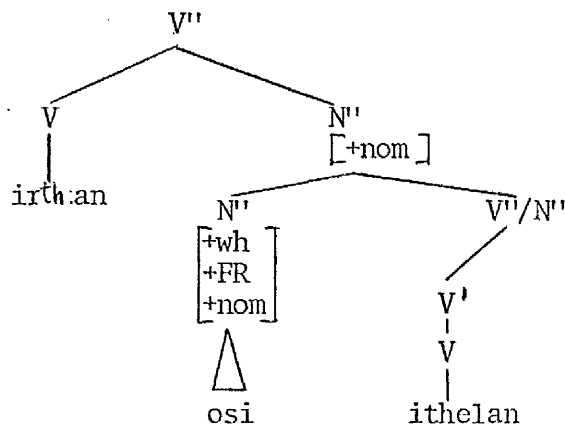

25. Tha dhosun epeno se osus edhosan ke perisi
will give-3rd pl. prize to whom(pl.) gave-3rd pl. and last year
They will give a prize to those they had given a
prize to last year as well
26. Tha valo ta khartya mu se opyo sirtari ta
will put-I the papers (of)-mine in what drawer them(clit.)
vazis ky esi
put-2nd s. and you
I'll put my papers in the drawer you put them in

In 25 the PP is marked as [+se] (see p. 24) functioning as a 'dative' - the case required by indirect objects in MG. We, thus, notice that for *wh*-relatives-adjectival and nominal - the indirect object is required to be expressed by a PP [+se]²⁸. In 26 the PP is a functional argument (cf. Jack. 1977:58) - locative complement. Rule 11 will be written as follows to account for these cases:

27.
$$\begin{array}{c} \left[\begin{array}{cc} P'' & V''/P'' \\ P'' & \left[\begin{array}{c} WH \quad FR \end{array} \right] \end{array} \right]$$

In 27 the features [WH FR] are, of course, foot features, ascending from the N'' governed by P'. Rule 27 shows clearly that the subcategorization requirements of the verbs in 25-26 are met - both verbs subcategorize a PP.

It seems that instances of the nominal clause functioning as the object of comparison or the possessive genitive with regard to the main verb are not available, naturally, since objects of comparison and possessive genitives are arguments and complements of A and N respectively.

We, thus, can turn to examples that exhibit the

observed 'conflict' between the two functions of the relative pronoun. These are cases like 16,17c,18b,19c, 20c. It is exactly in such cases where the phenomenon of the so-called ('progressive') 'attraction' is involved. What happens here is that the case of the relative pronoun - the head of the 'nominal' clause - is determined not by its syntactic relationship with its own - the subordinate-verb, but by its function with respect to the matrix verb. To put it more picturesquely, in the 'conflict' between the two verbs (the matrix and the subordinate) the winner is always the matrix verb²⁹. Example 16 is a striking illustration of that: the relative clause functions as the subject of the main verb (*irthan*), consequently, the relative pronoun must be in the nominative, as it is. But at the same time the relative pronoun is also the object of the subordinate verb. But there is no choice, since if the pronoun receives the case that the subordinate verb requires, the result is ungrammatical:

28: *?Irthan osus ghnoriza

29.a. Aghapo opyon me aghapa
love-I whom me(clit.) loves-3rd s.

b. *Aghapo opyoz me aghapa
love-I who me(clit.) loves-3rd s.
I love the one who loves me

The rules generating 28-29 are the same as those already given for subject, object etc. dependency nominal relatives. The following tree-diagrams will demonstrate the 'case' distribution in examples involving 'attraction' of case:

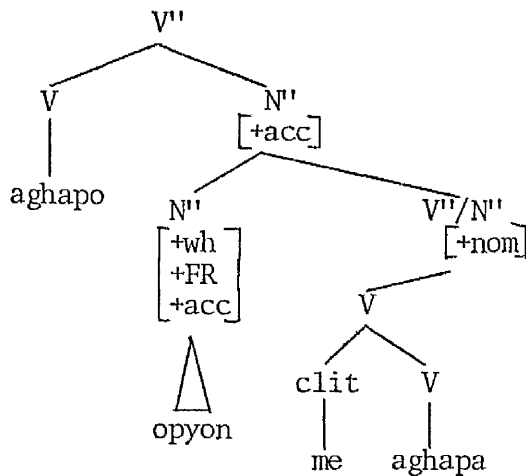
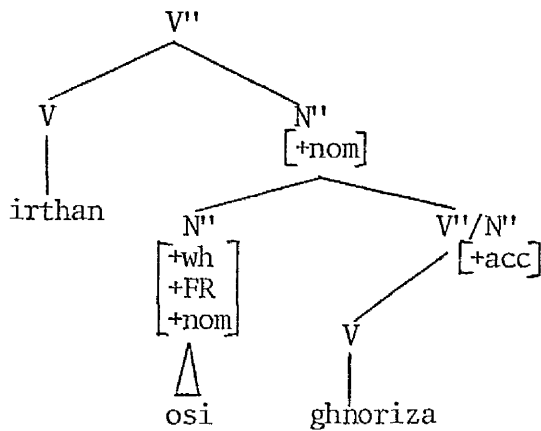

Given the above structures and our remarks accompanying them, the phenomenon of 'attraction' is a natural consequence of our analysis, according to which the *wh*-phrase at the beginning of the relative nominal clause is its head, and that case-marking as a HF goes down onto the head. We, thus, assume that the case of the 'slash N'' is free - not 'linked' to that of the *wh*-word, because the latter here is a *head*. This applies, of course, to the heads of adjectival relatives as well (which are, in terms of case, independent of the role of the relative pronoun in the subordinate clause); cf. the following

tree-diagram:

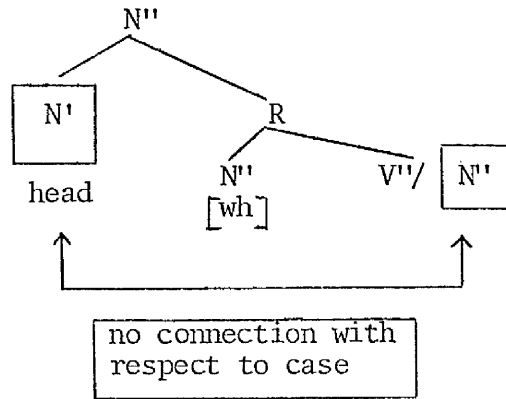

Given these facts and assumptions, we can further consider some more instances of the phenomenon of 'attraction'; this is also observed in the following example:

30. Tha valo ta rukha mu se opyo sirtari ine adhyo
 shall put-I the clothes (of)-mine in what drawer is empty
 I shall put my clothes in whichever drawer is empty

The structure underlying 30 is as follows:

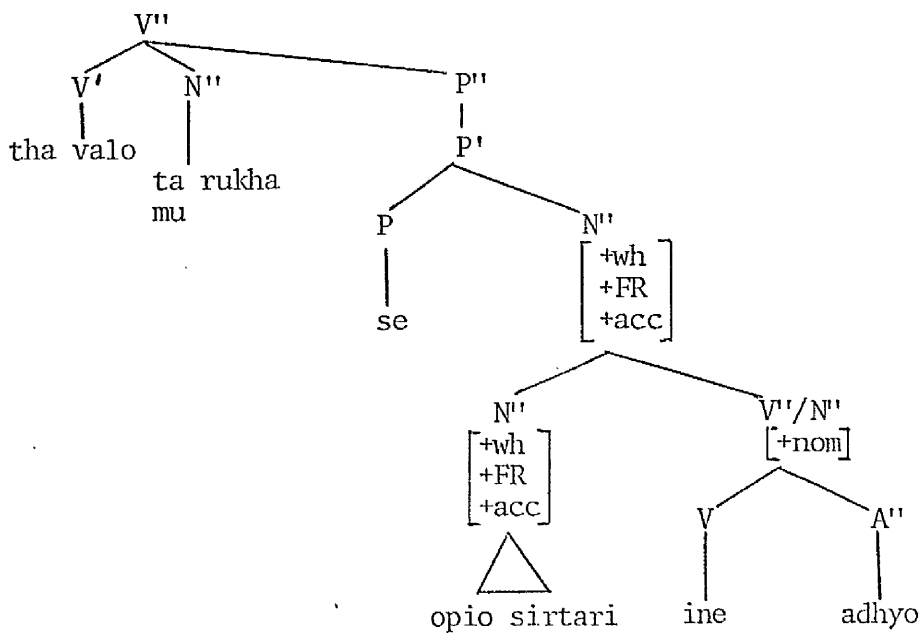

As becomes clear in the above structure, the main verb subcategorizes for a PP, consequently the NP following the preposition is necessarily in the accusative, whereas the dependency here is in subject position (in contrast with examples 25-26). This structure is the same as that underlying the sentence *aghapo opyon me aghapa* with regard to case distribution. In fact, given this distribution of case features, the phenomenon of attraction does not exist as such. Put very plainly, the *head* (in our analysis) of the free relative must satisfy the requirements of the governing V - that is all (e.g. $V' \rightarrow V N'' [+acc]$, $V'' \rightarrow V P'' [se]$ etc.). Along the same lines let us consider the following examples:

- 31.a. Tha valo ta rukha mu se opyu to sirtari
shall put-I the clothes (of)-mine in whoever's the drawer
ine adhyo
is empty
- b. Tha valo ta rukha mu sto sirtari
shall put-I the clothes (of)-mine in the drawer
opyu ine adhyo
of whoever's is empty
I shall put my clothes in whoever's drawer is empty

The structure underlying 31a is:

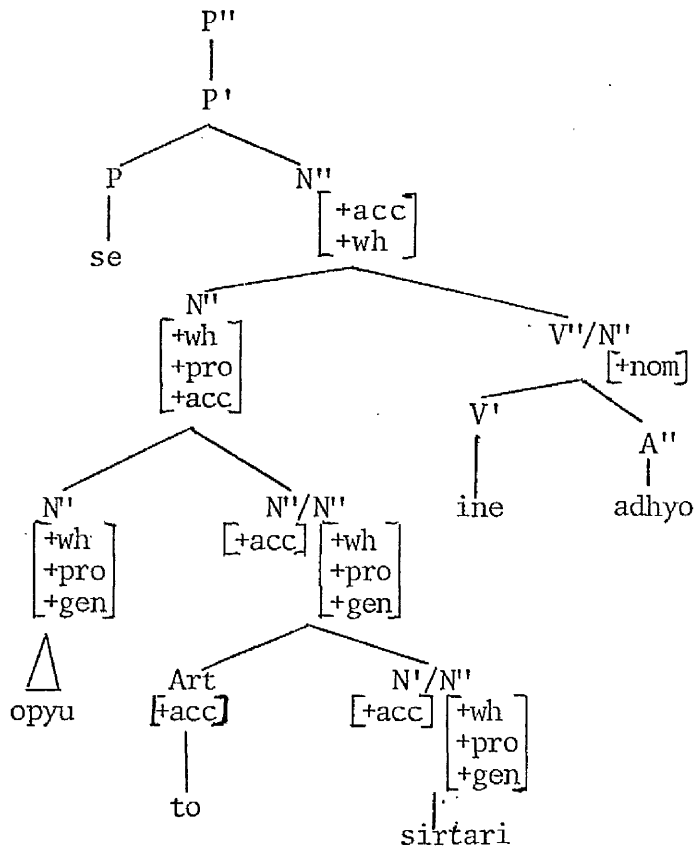

As the $V''/N'' [+nom]$ category indicates we have a subject dependency within the subordinate clause, but the case of the head NP $[+acc]$ is determined by the preceding P subcategorized for by the verb *vazo* (put) - $[+acc]$ is a head feature. What is of particular interest in the above structure is the dependency occurring within the head NP, namely, the dependency into the complement $[+gen]$ N'' position, which is explicit in the slash $N'' [+gen+wh+pro]$. The category $N''/N'' [+acc] [+gen]$ is responsible for the topicalized position of the pronoun *opyu*, and at the same time it blocks bad strings like:

31.c.*The valo ta rukha mu se opyu to sirtari $\left. \begin{array}{l} \text{tu Kosta ...} \\ \text{tu} \\ \text{emena} \end{array} \right\}$

The existence of this 'genitival' dependency is the only difference between 31a and 31b. In the latter, *opyu* is in its 'original' - i.e. 'non-topicalized'-position, consequently there is no need for this extra dependency into the N' complement position.

We can now turn to examples 17b, 19b and 20b, which are still bad despite the fact that the subcategorization needs of the main verb are met. The explanation of the ungrammaticality of such examples is very straightforward given the fact that the dependency within the clause here is in indirect object NP position, object of comparison position, and (possessive) genitive position-- i.e. in all those positions in which the dependency is realized as a resumptive pronoun, as we saw while discussing adjectival relatives. Clearly, the same is the case with nominal (free) relatives. Since in V" (the subordinate clause) the dependency is in NP positions that are relativized by leaving a pronoun in their place, we expect a resumptive pronoun. Thus, the ungrammaticality of 17b, 19b and 20b is restored if the clitic pronoun is inserted, as examples 17c, 19c and 20c show. We are, then, in a position to generalize our claims made earlier with respect to adjectival clauses, namely that if the dependency is into subject or object position there will be simply a gap in V" (and an optional clitic in indirect object position, accounted for by the optional rule of clitic doubling), but if the dependency is into an OBL(ique) NP, object of comparison or possessive genitive position, there will be a resumptive pronoun. The two slash elimination metarules we have already will give us these results. Furthermore, the subcategorization requirements of the matrix verb in the case of nominal relatives, are *always* met. The requirements of the subordinate verb are also met in the case where we get a resumptive pronoun, as we

go further down the hierarchy than DO position³⁰. It is crucial that this pronoun has always the case that the subordinate verb requires. It is, then, in this way that the 'compromise' is achieved when there is a 'conflict' between the subcategorization requirements of the two verbs - the matrix and the subordinate.

Having thus illustrated the phenomenon of 'case attraction' observed in nominal relatives and having also accounted for it in terms of our assumption that such relatives have as their head the *wh*-phrase introducing them, we are in a position to make another important remark: that, in fact, pied-piping is absent in most of the cases in nominal relatives, where it should normally occur. This is clear in 20c as well as in the following example:

32. Osi anthropi dhulepsa mazi tus ekhun pethani
as(many) people worked-I with them have 3rd pl. died
Those people I have worked with are dead

In 20c the nominal relative functions as the subject of the verb and the relative pronoun must be in the nominative; the clitic here (*tus*) complies with the case requirements of its governing verb. Similar is the situation in 32 - *tus*, governed by the adverb *mazi* (cf.p.298) meets the subcategorization requirements of the subordinate verb. So, the absence of pied-piping in cases like those exemplified above, accounted for by our theory according to which the *wh*-phrase is the head of the nominal clause, not the *wh*-phrase in the COMP position of the embedded S (and it is the co-occurrence of the *wh*-NP in COMP and pronoun in S that is bad, generally - cf.

**i anthropi me tus opius dhulepsa mazi tus,*o ipalilos*

ston opio edhosa s afton ta lefta 'the employee to whom I gave the money'-), permits the subcategorization requirements of the subordinate verb to be met. This is, more accurately, accomplished by the pronoun occurring in the place of pied-piping (and taken care of by the SEM II), as we we said earlier. In the light of this, we can contrast the structure underlying 31.a (p.375) to that of the corresponding example with a *wh*-adjectival relative (*stuo piu to sirtari*). In the latter, the *wh*-feature (i.e. *+wh*) appears under P" [+se], as a foot feature of course, which occupies the COMP position of the subordinate (relative) clause, but in the former the same feature is just under N" - i.e. the *head* of the relative clause (recall that the dependency here is in subject position and the [+acc] feature of the head is due to the preceding P, which, anyway, does not participate in the formation of the nominal relative). This difference between adjectival and nominal relatives automatically follows from the simple fact that the slash category of the relative clause agrees with the category bearing the *wh*-feature, but whereas the latter is the *wh*-phrase in COMP in adjectival relatives (and this agreement is obligatory), it is the *head* in nominal relatives (cf. p.363).

A final note concerns example 18b. Here the relative pronoun complies with the subcategorization requirements of the main verb as expected; namely, the nominal clause is the subject of the main verb. But the subordinate verb (*akubo*-put) subcategorizes for a PP (cf. *put on the table*). But in 18b there is nothing to indicate that. What we have here, in effect, is the omission of the PP, as we saw was the case in adjectival relatives, too (see IV A.3, 8). The adjectival *pu*-relative corresponding to 18b is

33. To trapezi pu akubises ti dileorasi khalase
the table that put-2nd s. the TV was damaged

It seems, then, that in free relatives, too, PPs may be omitted in much the same way and under the same conditions as in adjectival relatives.

3.2 Nominal relatives in non-argument position

So far we have considered cases of a nominal ('free') relative being in argument position with regard to the matrix verb. But since nominal relatives are in effect NPs, they can occupy, as already stated (p.364), every position usually occupied by an ordinary NP. Thus, they can appear in *non-argument* positions, too; i.e. they can be *topics*, as already clearly shown in examples 12-13, and further in

34. Opyos dhe milai ton thavume
who not speak him bury-3rd pl.
'They bury the one who does not speak'
35. Opya mana ekhi pedhya sto bolemo stalmena
which mother has children to the war sent
pes tis na mi da karteri
tell her(clit.) to not them(clit.) wait
'Tell the mother whose children have gone to
the war not to wait for them'
36. Osi parusiastikan tha tuz dhosun epeno
who appeared will them(clit.) give prize
They will give a prize to those present

What we should stress in the first place is the *obligatory* presence of the resumptive pronoun in the main

clause, its absence rendering the resulting sentences ungrammatical; e.g.;

35.a *Opya mana pes na min da karteri

36.a *Osi parusiastikan tha dhosun epeno
(in the intended meaning)

This clearly shows that the free relative here acts as a *topic*, and this is further supported by the sentence initial position occupied by it. The same facts are obtained in simple, ordinary, NPs; cf.:

37. Ton gathiyiti, {^{ton}_{*∅}} idhame

the professor (TOP), him saw-1st pl.

The professor, we saw

The second thing we observe in examples 34-36 is that the case of the relative pronoun (*opyos/osos*) here *complies with the case requirements of its own verb* - i.e. the subordinate verb - unlike in all the cases where the free relative had an argument position, as we saw previously. Before we propose a way to account for such cases it is worth mentioning that another type of 'case' attraction, so-called 'backwards' ('retreating') attraction (cf. Tzartzanos:271), is related to such topicalized free relatives. But notice that this sort of topicalization has an exact equivalent in simple NPs; cf.:

38. I kiria Irini, tin idha khthes sti Stadhiu

the Mrs Irene, her(clit.) saw-I yesterday at the Stadhiu (str.)

Mrs. Irene, I saw yesterday at Stadhiou Str.

39. Egho, mu aresun afta !
I, me(clit.) like-3rd pl. these !
These, I like !

Examples like 38-39, in which the initial NP is in the *nominative* case, whatever the case requirements of the verb are - these latter are clearly shown in the clitic pronoun which is always present and conforms to these requirements -, are considered by traditional grammar as instances of the 'anakolouthon' figure of speech. But it seems that 34-36 and 38-39 should be considered as instances of the same phenomenon and be treated together³¹. Along these lines, the same examples seem to provide strong evidence for a 'base' generation of topics in place; i.e. once the 'free' relatives are 'removed' from the sort of context where a V (or P) can assign case to the head, the 'head' naturally assumes the case appropriate to its role in its own clause. Because of that, the *wh*-word is now just like a real relative pronoun getting its case from its function within S - i.e. it does not look like a *head* NP. The following tree-diagrams illustrate the assumption that the *wh*-phrase of a 'topicalized' free relative behaves like the *wh*-phrase of a normal relative with respect to case assignment:

a.

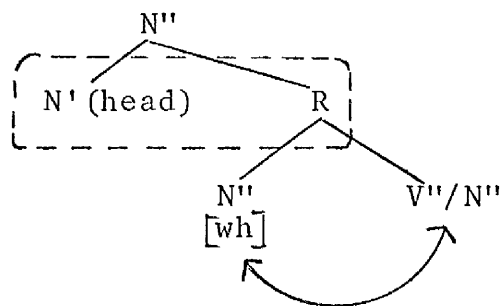

b.

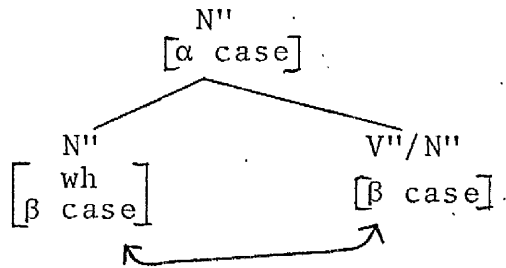

a. is the general tree schema for *wh*-adjectival relatives. The *wh*-N'' agrees with the slash N'' in case; i.e. NPs in non-argument positions inherit case from the argument position they were 'extracted from', to use the standard terminology of transformational grammar. What is put in the dotted circle in a is missing from b, which represents the general tree scheme of a nominal relative of the sort *osus ghnoriza*, when topicalized. The case of the upper N'' in b does not descend onto *wh*-N'', because the latter is not the head here: non-argument *wh*-NPs agree in case with slash NPs, just as in normal relatives. With these remarks in mind, let us consider the structure underlying *osus ghnoriza irthan*:

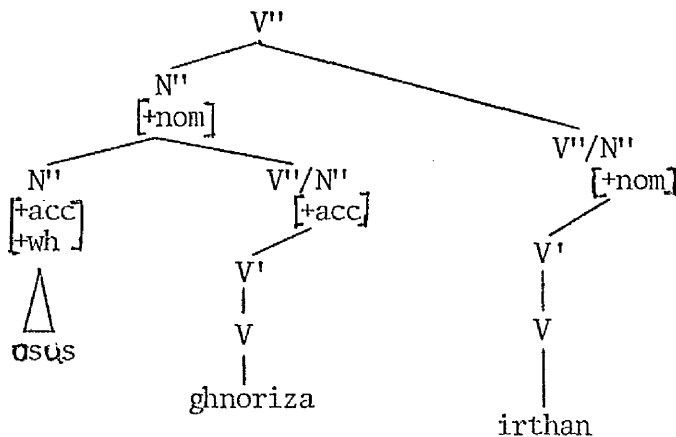

We can, then, draw the following conclusion: free relatives in argument positions have *wh*-heads (the *wh*-word corresponding to the *head* of a normal adjectival *wh*-relative). Such relatives exhibit the phenomenon called

'progressive' attraction by traditional grammar. Free relatives in non-argument positions are *headless* (the *wh*-phrase here corresponds to the *wh*-phrase in an adjectival *wh*-relative). Such free relatives are related to the phenomenon of 'backwards' attraction. If these conclusions are correct, the following two rules are needed for nominal relatives in MG:

A.
$$\begin{array}{c} N'' \\ [\alpha \text{ case}] \end{array} \left[\begin{array}{c} N'' \\ [+WH] \\ [\alpha \text{ case}] \end{array} \right] V''/N''$$

B.
$$\begin{array}{c} N'' \\ [TOP] \end{array} \left[\begin{array}{c} N'' \\ +WH \\ [\alpha \text{ case}] \end{array} \right] \left[\begin{array}{c} V''/N'' \\ [\alpha \text{ case}] \end{array} \right]$$

In A the $N'' [+WH]$ is the head; here there is no reason to expect the head and the slash N'' to agree in case. Clearly, only the rule A - hence nominal relatives in argument positions - provides support for Bresnan and Grimshaw's claims about free relatives being 'headed' by the *wh*-phrase. For topicalized nominal relatives accounted for by rule B this theory is inapplicable, for such relatives are 'headless'.³²

4. Summary

In this sub-chapter I proposed an analysis of nominal relative clauses. Starting by adopting Bresnan and Grimshaw's analysis, we saw that this captures facts of nominal relatives occupying argument positions, since these relatives appear to be 'headed' by the *wh*-phrase introducing them, but it clearly cannot account for

topicalized relatives (those occupying the non-argument position of a topic), since there is good evidence for considering these as 'headless' - the *wh*-phrase here is just like the *wh*-NP of adjectival relatives. I proposed rules A and B for argument and non-argument nominal relatives respectively. Also, the two slash elimination metarules we used for adjectival relatives give us all the right results in nominal relatives, too. Thus, what happens to the slash NP (V"/N", see rule 11 p.363) depends on whether we have a dependency into subject or (direct) object position on the one hand ('gap' in S), or into an OBLIQUE case NP or a possessive or an object of comparison position on the other (full or clitic pronoun in the accusative or genitive, depending on the governing category).

NOTES

1. However, it seems that appositives refer to the whole predicate rather than just the adjective phrase, cf. the ungrammatical:

*...enas {anthropos psilos} , pu esi pote dhe tha yinis..
 {psilos anthropos}
 ...a {man tall} that you never not will be...
 {tall man}

A tall man, which you'll never be...

In that case the generalization concerns the VP rather than just the AP. There is another set of cases, in which only a restrictive is allowed:

san {musikos } pu ise tha xeris oti...
 {psilos }
 {sostos }
 {dhikighoros}

as {musician } that are-you will know-2nd s. that...
 {tall }
 {right man }
 {lawyer }

Asthe {musician} that you are, you will know...
 {... }
 {... }

Clearly here the RC is built on a 'predicate' NP rather than a 'referring' NP - i.e. we are dealing with a property predicated of someone, not with an entity.

2. Jackendoff (1977) cites the following examples:

The man who came to dinner who hated lox...

*The man, who came to dinner, who hated lox...

3. This sort of relative presents an interesting problem with respect to coordination itself. Are both relatives restrictives or is the first restrictive and the second appositive (in case there is a pause before the latter) ? A positive answer to this would violate the basic principle of coordination - that of 'like' categories. Thus, there is nothing against considering both relatives as conjoined restrictives. The relevant structure will be:

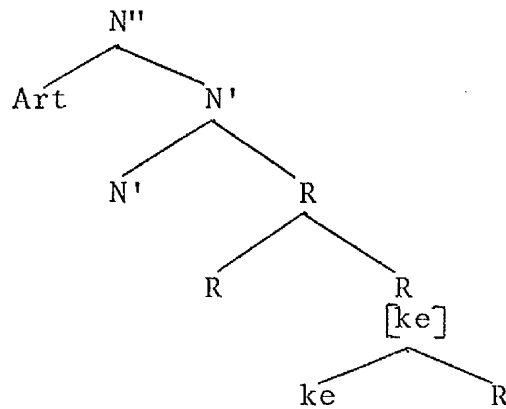

This one structure can have two interpretations: (a) if there is no pause between the two R, then we are defining the individual progressively more precisely - in some sense the 1st conjunct is insufficient by itself to identify the referent, so it must be further qualified; cf. in English

The man I met (and) who I told you about..

not

The man I met (and) who was nice to you (e.g. there are two men I met).

This reading corresponds rather to a 'stacked' reading for restrictives (as in English, where we do get this 'stacked' reading). (b) If we pause between the two

conjuncts we are simply providing two separate pieces - of equal value - of information by means of which the referent can be identified - either would suffice by itself. This reading is that of conjoined sentences in the conventional sense.

4. Cf. "the descriptive content of a definite NP operating as a definite description will be more or less detailed according to the circumstances; and the manner of description will often depend upon the speaker's assumption that the hearer is in possession of quite specific information about the referent" (Lyons 1977, 1: 180).

5. The real difficulty with this distinction between restrictives and appositives is found in sentences like:

to pedhi pu oli nomisan pos to khtipise aftokinito...
the child that all thought that it knocked down car...
*The child that all believed that was knocked down
by a car...

where the RC is definitely restrictive, yet it contains the clitic pronoun. We may assume (as in note 6 below) that since the RC is unambiguously restrictive (cf. *pyo pedhi* ?) the clitic serves some other purpose this time, its absence ceasing to be operative with respect to the restrictive/appositive distinction; in fact it helps the hearer to 'recall' the head NP to which the RC is referring, since now, due to the interference of the embedded clause *oli nomisan pos*, it is quite remote from it. In fact we have a long distance ~~un~~bounded dependency and the resumptive pronoun must be considered as the result of the 'clitic doubling' rule (cf. 3.5)

related to constructions containing such a dependency (cf. Horrocks 1983). We should notice that the clitic pronoun belongs to the clause introduced by the complementizer *pos*. Of course, in these cases the clitic may also be absent without any effect with respect to the grammaticality of the resulting sentence.

6. Rarely, in RCs unambiguously interpreted as appositives the object clitic can be omitted. If we accept that its presence or absence marks the distinction between restrictives and appositives, then it might be natural to assume that once a RC is interpreted as appositive independently of the presence of the clitic (see 1.2.2), the latter does not serve its purpose any longer and can be omitted. This is perhaps circular, but I cannot explain it in any other way.

7. Cf. "Since *he* in *John looked up when he came in* bears heavy stress, the expression '*he*' of which it is a form, may be either deictic or anaphoric in particular utterance-tokens. If '*he*' is deictic, there will usually be some concomitant paralinguistic feature (a nod of the head, a gesture with the hand etc.) which draws the attention of the addressee to the referent in the situation of-utterance... The prosodic feature of stress is relevant to the reference of '*he*' only in so far as it increases the probability of a deictic interpretation. But whether the pronoun is interpreted as having anaphoric or deictic reference (or both) would seem to depend primarily upon the context-of-utterance..." (Lyons 1977, 2:661). The term 'anaphoric' corresponds partly to our 'definite' (or 'repetitive').

8. As has been pointed out, (Gazdar 1981) R and Q are motivated separately by the difference between relative and interrogative pronouns, just as it is the case in MG. This may seem not to comply with the view that points out the morphological relationship between interrogative and relative pronouns existing in most Indo-European languages, which has been considered to underly the semantic relationship between restrictive RCs and X-questions containing an indefinite/interrogative pronoun - like the English *who* (Lyons 1977, 2:757-759). However, the differentiation that overtly exists in many languages (including MG, cf. interrogative *pyos*, relative *o opios*, indefinite *kapyos*) is necessary in a purely synchronic syntactic account of these categories - whatever their diachronic relationship.

9. Cases where the clitic pronoun can be heard in a *wh*-RC with a (direct) object dependency are marginal, and I do not have anything to say about them. I believe that this must be explained in terms of influence (analogy?) of the rule of 'clitic doubling' (cf. note 5). Needless to say, WH Relatives *never* appear in writing with a clitic pronoun (not even when they are appositives). Neither should sentences like... *ton opio an don dho* (the whom if him see-I) be considered as counterexamples to the generalization made, since the clitic *ton* here belongs to the conditional - and not the relative-clause.

10. It seems that in the P-Adv-P sequence, the Ps that follow and precede the Adv are obligatorily the same (cf. *apo* *exo* *apo*...), and there must be a way accounting for it, but this is irrelevant to the points we are considering here.

11. I am not quite sure if the *wh*-node in these cases is always the AdvP, because of the dubious status of examples *?to ktirio apo to opio perasa brosta*, *?o kipos apo ton opio perasa exo*. If we take these as grammatical, then Advⁿ must be allowed on the projection path, the *wh*-node will be Pⁿ and the corresponding 'hole' must be Pⁿ/Pⁿ, located within the AdvP-complement of V. But this runs into difficulties with regard to SEM I, which requires the 'gaps' to be properly governed by V only.

12. Similarly, in the case of sentences like *o kirios tu opiu o pateras erghazete...* that the *wh*-NP of the RC is the whole *tu opiu o pateras (or o pateras tu opiu)* is supported by the non-existence of

?*O kirios tu opiu erghazete sti drapeza o pateras
?* " " " " erghazete o pateras sti drapeza

It is worth mentioning, however, that in corresponding RCs with object dependencies like:

O kirios tu opiu to onoma xekhno

we can have

O kirios tu opiu xekhno to onoma...

This 'weird' asymmetry between the two cases of RCs suggests that the * status of the separation of genitive *wh*-phrase and nominative NP does not derive from the separation but from other considerations. I do not know which.

13. RCs with a comparative genitive dependency fall into the category of relatives with a PP dependency, since the 'object of comparison' is simply an ordinary

apo PP here:

O anthropos *apo ton opio* ime kaliteros...
the man from the whom am-I better...

The man than whom I am better

O filoz mu *apo ton opio* ime psiloteros...

the friend (of)-mine from the whom am-I taller....

My friend than whom I am taller...

14. Of course, the relative pronoun can always be repeated in its appropriate form in the second conjunct (*o opios... ke ton opio... etc.*). But this is something different from the point we want to make, since in that case any kind of (relative) clauses can be conjoined. They must be considered as two distinct sentences of the category R, the conjoinability of which is not required to depend on their internal structure, but just on the category R of both.

With regard to conjoined object and subject relatives an unexpected problem arises when we meet sentences like:

o anthropos o opioz milise ke ton idhes ke si...

the man the who talked and him saw-2nd s. and you...

because of the appearance of the clitic pronoun in the 2nd conjunct. But we can solve that by considering the two conjuncts as two separate sentences, cf. in English

[This is the man who spoke]_s and [you saw him]_s.

Then, there is nothing to prohibit the presence of the clitic in the second conjunct.

15. 78a-b are bad if read as intended rather than as if the 2nd conjunct were a separate (e.g. non-relative) clause, in which case 78b could also, naturally, contain the object clitic (see note 14).

16. Here again, if the WH-pronoun is repeated in the 2nd conjunct, no problem arises (cf. note 14), (*o opios irthe ke me ton opio milises* etc.), since in that case we are no longer interested in the internal structure of the conjoined clauses (i.e. the type of the slash category involved). Here we simply have two conjoined sentences, both of the category R.

17. As another difference between the two 'introducers' of RCs we can mention the common adjectival use of the WH-pronoun *o opios* as shown in:

...*o opios* Yanis dhe fanike katholu
...the who John not appeared-3rd s. at all...
John, who didn't appear at all...
...to *opio vivlio* mu kostise...
the which book(to)-me costed...
The book which cost to me ...

Not surprisingly, this use is excluded with *pu*:

pu o Yanis ...
*{*o pu* Yanis}

pu to *vivlio* ...
**{*to pu* *vivlio*}

18. I assume that the rather peripheral cases where an emphatic full pronoun turns up are the product of

distinct rules, independent again of Restrictive RC-formation. Notice that this emphatic pronoun appears before the verb, not after it - i.e. in 'focus'/'topic' position, as we would expect:

..?pu *afto* dhyavasa...

..*pu dhyavasa *afto*... (cf. p.267)

19. We can further notice that it is more difficult to get in parallel with *pu to onoma tu xekhno*, things like

O kirios pu tu pedhyu tu (tu) ekanan enkhirisi...

the man that (of)-the child (of)-his (to-him)made-3rd pl.operation .

The man whose child underwent an operation...

We get more easily

o kirios pu ekanan enkhirisi tu pedhyu tu

Furthermore, it is again difficult to get:

...pu tu filu tu pedhyu tu (tu) ekanan enkhirisi...

...that(of) -the friend(of)-the child (of)-his (to-him) made-3rd pl.
operation

...whose child's friend underwent an operation

corresponding to *pu to onoma tu patera tu xekhno*... I presume this 'asymmetry' is a performance (processibility) factor (it may have an aesthetic dimension as well).

20. We are thus in a position to explain another fact: the non-distinction between appositives and restrictives by means of the clitic pronoun in the case of IO relatives: since in DO relatives the strategy of the clitic

pronoun is not needed (as DO NPs stand high on the AH), the latter is not 'grammaticalized' - not required by the syntax -, thus it is 'free' to be used for other purposes. So it marks the distinction between restrictives and appositives. On the other hand, the clitic is often needed in the case of IO relatives - i.e. it *is* grammaticalized - so it is not available for a further distinction - that between restrictives and appositives. The same is even clearer in all the following positions of the AH-OBL, GEN, O COMP.

21. It is a mystery, though, why the topicalized versions are by far more natural and why many of the non-topicalized versions are even ungrammatical, cf.:

??*to khoryo pu kataghome apo afto*, the village from which I come, ??*to spiti pu yenithika s afto*, the house in which I was born, **tu axize to arista pu ton vathmologyisan m afto*, he deserved the mark 'best' with which he was marked, etc. The P" can, of course, be the focus if it is emphatically stressed.

22. In fact, as they are defined (see p. 350) PPs marked as [+m] seem to be both complements of V (functional arguments other than IO) and complements of V' (restrictive modifiers). Thus, PPs [+m] comprise also the OBL(ique) case of Keenan @ Comrie.

23. I think that this NP-complement theory has been well established since 1977, and that we need not mention here all the arguments that have been put forward to show the deficiencies of the popular Chomsky-adjoined theory, according to which the RC is attached up to N^{'''}, or the determiner theory, which, anyway required an otherwise unmotivated extraposition rule to move the RC from within the determiner to a position after the (head) noun.

24. But unlike the English *ever*, *-dhipote* does not exist as an independent lexical item, it is always bound to the (relative) pronouns (optionally).

25. The presence of the suffix *-dhipote* cannot be considered as amounting to the "obviously false claim that... it has to appear in free relative heads" (Gazdar 1980:78, note 38).

26. Called, descriptively, 'base hypothesis' (Br. @ Gr. 1978).

27. 23 is bad if *afti*, *i mathitries*, *egho* are meant as subjects of the main verb (*irthan*), not of the subordinate (*ithelan*).

28. There are very rare cases - their grammatical status not agreed upon - where the genitive case of the relative 'nominal' pronoun can express the IO; cf.:

?tha dhosun epeno *oson* edhosan ke perisi (cf. p. 24)

29. It is worth mentioning that this is the opposite of what happens in Finnish, where as mentioned by Br. @ Gr. (citing Carlson), "when the case requirements of the matrix and subordinate verb conflict, the head of the free relative clause agrees with the subordinate verb" (p. 373).

30. The following example exhibits an NP dependency in Advⁿ in nominal relatives:

Opyo trapézi akubisis pano tu ti dileorasi
which table put-2nd s. on it(clit) the TV
tha to paris
will takè-2nd s.

You will buy the table which you will put the TV on
I have no explanation for why we easily get NP dependen-
cies into Adv["] but not so easily into P["] in nominal rela-
tives. This is clearly a peculiar 'asymmetry': cf.:
?oses kopeles se vlepo m aftes... (but cf. 32).

31. For simple topicalized NPs (like that of 37) the
following rule can be proposed:

$$v'' \left[\begin{array}{l} N'' \\ [+nom] \\ [+TOP] \end{array} \quad \begin{array}{l} V''/N'' [+TOP] \\ [\alpha \text{ case}] \end{array} \right]$$

(cf. Horrocks 1983:103).

32. Within a standard *wh*-movement analysis, such to-
picalized nominal relatives would be moved to *head* po-
sition by *wh*-movement after having got their case ac-
cording to their original position in S. But this ana-
lysis will have also to explain why the head NP[+wh]
loses its 'original' case.

BIBLIOGRAPHY AND REFERENCES

- Akmajian, A. (1975) "More evidence for the NP cycle,"
Linguistic Inquiry 6.115:127.
- Akmajian, A. @ Lehrer, A. (1976) "NP-like Quantifiers and
the Problem of Determining the Head of an NP." *Linguistic
Analysis* 2:395-413.
- Allan, K. (1977) "Classifiers." *Language* 53:285-372.
- Allwood, J., Andersson, L.-G., @ Dahl, Ö. (1977) *Logic
in Linguistics*, Cambridge: Cambridge Univ. Press.
- Anastassiades-Symeonides, A. (1981) "Problèmes de lexicologie:
une espèce d'"unité syntagmatique" en grec
moderne." In *Studies in Greek Linguistics*, Proceedings
of the 2nd annual meeting of the Department of Linguistics,
Aristotelian University of Thessaloniki, 213-229.
- Andrews, A. (1971) "Case Agreement of Predicate Modifiers
in Ancient Greek," *Linguistic Inquiry* 2:127-152.
- Bach, E. (1974) *Syntactic Theory*, Holt, Rinehart @ Winston.
- Bache, C. @ Jakobsen, L.K. (1980) "On the distinction between
Restrictive and non-Restrictive Relative Clauses
in Modern English." *Lingua* 52:243-267.
- Baltin, M. (1980) "On the notion Quantifier-Phase," *Linguistic
Inquiry* 11:247-249.
- Bolinger, D. (1967) "Adjectives in English: Attribution
and Predication," *Lingua* 18:1-34.
- Borsley, R. (1981) "WH-movement and unbounded deletion
in Polish Equatives," *Journal of Linguistics* 17:271-288.
- Bowers, J. (1975) "Adjectives @ Adverbs in English,"
Foundations of Language 13:529-562.
- Bresnan, J. (1973) "Syntax of the Comparative Clause Construction
in English," *Linguistic Inquiry* 4:275-343.

- Bresnan, J. (1976) "Evidence for a Theory of Unbounded Transformations," *Linguistic Analysis* 2:353-394.
- Bresnan, J. (1977) "Transformations and categories in syntax." In Butts and Hintikka, eds., *Basic Problems in Methodology and Linguistics*. D. Reidel, Dordrecht, Holland.
- Bresnan, J. @ Grimshaw, J. (1978) "The Syntax of Free Relatives in English," *Linguistic Inquiry* 9:1-111.
- Burton-Roberts, N. (1975) "Nominal apposition," *Foundations of Language* 13:391-419.
- Carlson, G. (1977) "Amount Relatives," *Language* 53:520-543.
- Chomsky, N. (1965) *Aspects of the Theory of Syntax*, Cambridge, Ma.:MIT Press.
- Chomsky, N. (1970) "Remarks on nominalization," in *Readings in English transformational grammar*, ed. by R. Jacobs and P. Rosenbaum, 184-221, Ginn, Waltham, MA.
- Chomsky, N. (1973) "Conditions on Transformations", in S.R. Anderson and P. Kiparsky, eds. *A Festschrift for Morris Halle*, 232-286. New York. Holt, Rinehart and Winston.
- Chomsky, N. (1976) "Conditions on Rules of Grammar," *Linguistic Analysis* 2:303-352.
- Chomsky, N. (1977) "On Wh-movement" in Culicover P. et al. eds. (1977), 71-132.
- Chomsky, N. (1980) "On Binding," *Linguistic Inquiry* 11:1-46.
- College Syntax of Dhimotiki* (1976). Edition of the Athens College.
- Culicover, P., Wasow, T. @ Akmajian, A., eds. (1977) *Formal Syntax*, Academic Press. New York.
- Delorme, E. @ Dougherty, R. (1972) "Appositive NP Constructions," *Foundations of Language* 8:2-29.
- Emonds, J. (1976) *A Transformational approach to English Syntax: Root, Structure Preserving and Local Transformations*. Academic Press. New York.

- Gathercole, V. (1981) "Support for a Unified QP analysis," *Linguistic Inquiry* 12:147-148.
- Gazdar, G. (1979) *A phrase structure syntax for comparative clauses*. Mimeo. Published also (1980) in T. Hoekstra, H.v.d Hulst, M. Moortgat, eds., *Lexical Grammar*. Dordrecht: Foris Publications.
- Gazdar, G. (1980) *Phrase structure grammar*. Mimeo. Also In Pauline Jacobson and Geoffrey Pullum, eds. (1982), *The Nature of Syntactic Representation*, 131-186. D. Reidel Dordrecht, Holland.
- Gazdar, G. (1981) *Unbounded dependencies and coordinate structure*. Mimeo. Also in *Linguistic Inquiry* 12:155-184.
- Gazdar, G., Klein, E., Pullum, G., & Sag, I. (1982) *Coordinate Structure and Unbounded Dependencies*. Mimeo. Also in Barlow, M., Flickinger, D., Sag, I., eds., *Development in Generalized Phrase Structure Grammar*. Bloomington: IULC.
- Gazdar, G. & Pullum, G. (1982) *Generalized phrase structure grammar: a theoretical synopsis*. Mimeo. Indiana University Linguistics Club.
- Harman, G. (1963) "Generative grammars without transformation rules: a defense of phrase structure." *Language* 39:597-616.
- Hogg, R.M. (1977) *English Quantifier Systems*. North Holland, Amsterdam, New York, Oxford.
- Horrocks, G. (1983) "The order of constituents in modern Greek." In G. Gazdar, E. Klein, and G. Pullum, eds., *Order, Concord, and Constituency*, 95-111. Foris, Dordrecht, Holland.
- Horrocks, G. (1983^a) *The lexical head constraint, X̄-theory and the 'pro-drop parameter'*. Unpublished manuscript.
- Horrocks, G. & Gazdar, G. (1981) *Greek Relatives Revisited*. Unpublished paper.

- Horvath, J. (1976) "Focus in Hungarian and the \bar{X} Notation," *Linguistic Analysis* 2:175-197.
- Huckin, T. (1977) "The Nonglabality of *-er* Suppletion," *Linguistic Analysis* 3:217-226.
- Huddleston, R. (1976) *An Introduction to English Transformational Syntax*. Longman.
- Jackendoff, R. (1968) "Quantifiers in English," *Foundations of Language* 4:422-442.
- Jackendoff, R. (1977) *\bar{X} -Syntax: a study of phrase structure*. MIT Press, Cambridge, MA.
- Jackendoff, R. (1980) "On the constituent structure of All Three of the Men," *Linguistic Inquiry* 12:150-151.
- Jacobs, R. @ Rosenbaum, P., eds. (1970) *Readings in English Transformational Grammar*. Ginn, Waltham, Massachusetts.
- Joseph, B. (1980) "Recovery of information in relative clauses: evidence from Greek and Hebrew," *Journal of Linguistics* 16:237-244.
- Keenan, E. @ Comrie, B. (1977) "Noun Phrase Accessibility and Universal Grammar," *Linguistic Inquiry* 8:63-100.
- Kirkwood, H.W. (1977) "Discontinuous noun phrases in existential sentences in English and German," *Journal of Linguistics* 13:53-66.
- Kuno, S. (1972) "Functional Sentence Perspective," *Linguistic Inquiry* 3:269-320.
- Kuno, S. (1974) "The position of Relative Clauses and Conjunctions," *Linguistic Inquiry* 5:117-136.
- Langacker, R. (1974) "Movement rules in functional perspective," *Language* 50:630-664.
- Lees, R. (1960) "A multiply ambiguous adjectival construction in English," *Language* 36:207-221.
- Lees, R. (1961) "Grammatical Analysis of the English Comparative Construction," *Word* 17:171-185.

- Levi, J. (1973) "Where do all those other adjectives come from ?" *Papers from the ninth regional meeting of the Chicago Linguistic Society*, 332-345.
- Levi, J. (1974) "On the alleged idiosyncrasy of non-predicate NPs," *Papers from the tenth regional meeting of the Chicago Linguistic Society*, 402-415.
- Lyons, J. (1968) *Introduction to Theoretical Linguistics*. Cambridge University Press, Cambridge, England.
- Lyons, J. (1977) *Semantics*, 2 vols. Cambridge: Cambridge Univ. Press.
- McCawley, J. (1968) "The role of semantics in a grammar," in *Universals in Linguistic Theory*, Bach, E. and Harms, R., eds., 125-170. New York. Holt, Rinehart & Winston.
- Neoelliniki Ghramatiki (tis Dhimotikis)* (1978). Institute of Modern Greek Studies, Univ. of Thessaloniki. Thessaloniki.
- Quirk, R. & Greenbaum, S. (1973, 1978¹¹) *A University Grammar of English*. Longman Group Ltd. Harlow.
- Radford, A. (1981) *Transformational Syntax (A student's guide to Chomsky's Extended Standard Theory)*. Cambridge Textbooks in Linguistics, Cambridge Univ. Press.
- Reibel, D. & Schane, S., eds. (1969) *Modern Studies in English*, Prentice Hall, Englewood Cliffs, New Jersey.
- Rivero, M.L. (1980a) "On Left-Dislocation and Topicalization in Spanish," *Linguistic Inquiry* 11:363-393.
- Rivero, M.L. (1980b) "Theoretical Implications of the Syntax of Left-Branch Modifiers in Spanish," *Linguistic Analysis* 6:407-461.
- Ross, J.R. (1977) *Constraints on variables in syntax*. Unpublished Ph.D. thesis, MIT.
- Sampson, G. (1973) "The irrelevance of transformational omnipotence," *Journal of Linguistics* 9:299-302.

- Schachter, P. (1977) "Constraints on coordination,"
Language 53:86-103.
- Selkirk, E. (1977) "Some remarks on noun phrase structure,"
in Culicover, P. et al., eds. (1977) 285-316.
- Siegel, M. (1976) *Capturing the Adjective*. Ph.D. Thesis,
University of Massachusetts.
- Sifaki-Stavrou, M. (1981) "Partitive and Pseudopartitive
Noun Phrases in Modern Greek". In *Studies in Greek
Linguistics*, Proceedings of the 2nd annual meeting
of the Department of Linguistics, Aristotelian Univer-
sity of Thessaloniki, 79-113.
- Sifaki-Stavrou, M. (1982) "Some remarks on the comparative
complements in Modern Greek." To appear in *Studies in
Greek Linguistics*, Proceedings of the 3rd annual meet-
ing of the Department of Linguistics, Aristotelian
University of Thessaloniki.
- Simeonides, A. see Anastassiades-Symeonides, A.
- Smith, C. (1961) "A class of complex modifiers in
English," *Language* 37:342-365.
- Smith, C. (1964) "Determiners and Relative Clauses in a
Generative Grammar of English," *Language* 40:37-52.
- Stavrou, M. see Sifaki-Stavrou, M.
- Stockwell, R., Schachter, P. @ Partee, B.-Hall (1973)
The Major Syntactic Structures of English, New York,
Holt, Rinehart @ Winston.
- Sussex, R. (1974) "The deep structure of adjectives in
noun phrases," *Journal of Linguistics* 10:111-131.
- Theophanopoulou-Kontou, Dh. (1982) "MG *pu* Relative Clau-
ses and the omission of the preposition." To appear
in *Studies in Greek Linguistics*, Proceedings of the
3rd annual meeting of the Department of Linguistics,
Aristotelian University of Thessaloniki.

- Tzartanos, A. (1946²) *Neoelliniki Syntaxis (tis kinis dhimotikis)*. Orphanismos Ekdhoseon Skholikon Vivlion. Athens.
- Warburton, I.P. (1977) "Modern Greek clitic pronouns and the 'surface structure constraints' hypothesis," *Journal of Linguistics* 13:259-281.
- Williams, E. (1977) "Across-the-board application of rules," *Linguistic Inquiry* 11:624-631.
- Williams, E. (1978) "Across-the-board rule application," *Linguistic Inquiry* 9:31-43.
- Woolford, E. (1978) "Free Relatives @ other base generated WH Constructions," *Papers from the fourteenth regional meeting of the Chicago Linguistic Society*.