

2015 International Nuclear Atlantic Conference - INAC 2015
São Paulo, SP, Brazil, October 4-9, 2015
ASSOCIAÇÃO BRASILEIRA DE ENERGIA NUCLEAR - ABEN
ISBN:

FLOW MEASUREMENTS IN HYDROTRANSPORT UNITS USING GAMMA SCATTERING AND CROSS-CORRELATION TECHNIQUES

Umberto C. C. S. Siciliano^{1 2}, Giselle M. Araújo¹, Luís E. B. Brandão² and César M. Salgado²

¹ Departamento de Engenharia Metalúrgica e de Materiais
Escola Politécnica – COPPE/ UFRJ
Ilha do Fundão
21941-972 Rio de Janeiro, RJ
ucsiciliano@metalmat.ufrj.br
giselle@metalmat.ufrj.br

² Divisão de Radiofármacos - DIRA
Instituto de Engenharia Nuclear IEN - CNEN
Rua Hélio de Almeida 75
21941-906 Rio de Janeiro, RJ
brandao@ien.gov.br
otero@ien.gov.br

ABSTRACT

The proposal of this research was to develop a methodology using gamma radiation and cross-correlation techniques to measure the speed of ore pellets in a hydrotransport duct. An experimental unit was designed and built to be used in a two-phase flows transport simulation. It was used to measure the velocity of the solid pellets. The flowmeter system consists in two independent systems, each one composed by a NaI (1x1") scintillators detector- ²⁴¹Am gamma source, installed outside the tube, both systems were located in the same vertical plane and separated by 18.0 cm. As pellets, were produced a variety of specimens with different compositions in order to verify the methodology. Using this flowmeter was possible to calculate the solid phase velocity.

1. INTRODUCTION

Accurate measurement of mass flow of a given product is essential for the proper control of the various operations that occur in the industrial environment.

In hydrotransport systems, a solid phase flows inside a pipe using water as carrier and the measurement of solids velocity is a complex problem due to the chaotic behavior of this two-

phase system (the irregular shape/sizes of the pellets and the inhomogeneous distribution within the liquid phase).

The great advantage of the use of nuclear techniques to measure the flow is mainly because it performs analyses without influence in the plant operation and the device is a non-invasive meter, this reduces the damage caused by solid material contact with the measuring device.

Additionally, because the high sensitivity of detection systems, low intensity radiation sources were used. This minimize the radiological hazard and without causing any damage or contamination to the equipment and the environment.

2. HYDROTRANSPORT

Various industries use pipelines, as a mode of transport of solids because of its low maintenance and these units can be operated 24 hours/day every day. And this mode of transportation is extremely safe and the most eco-friendly compared to others modes of transportation of solids in bulk form.

To determine the mass flow rate in a hydrotransport system are not simple because two experimental parameters must be measured simultaneously: the mean velocity and the volumetric concentration of solid phase. In these pipelines, pellets are moving with low velocity and the main problem is to understand the liquid phase forces acting upon the solid phase and the effects of these forces upon the velocity of pellets.

An important parameter is a critical sedimentation velocity; this corresponds to the smallest value for the pellets' velocity, which there is no risk solid phase sedimentation. This parameter depends on the following factors: pellets size and density, tube diameter, solid phase concentration. However there is a upper limit for the pumping, defined as the velocity that minimize the wear caused by pellets contact with the pipe wall.

At last, a monitoring system should be designed to control the pulp movement inside the pipe, in order to detect leaks or blockage to reduce the possibility of disruption. It should be remembered that a monitoring program results in an optimal performance, resulting in a maximum efficiency. [1]

3. METHODOLOGY

The pipeline simulation unit is shown schematically in Figure 1. It consists in a rigid, transparent vertical pipe of internal diameter $D = 69$ mm and 2000 mm long in which flows the solids pellets. In this first study, the aqueous phase was motionless and the solid phase was moving in free fall only considering the action of water forces and the collisions between the particles.

As measure system was used two sets gamma source-scintillators detector each one composed by a ^{241}Am disk gamma source (5 mm diameter) and a NaI (1x1”) scintillators detector diametrically opposed to the source. Both system were aligned and fixed outside of pipe. This unit has a PVC platform where the detectors were mounted (named D1 and D2) to register the movement of pellets. The platform allowed the installation of a third detector D3, coplanar to D2 to study the solid flow profile and calculate the solid mass fraction. However, this will be the subject of a future study. The velocity was calculated measuring the transient time between the position of D2 and D1 scintillators detectors .To do this we used cross correlation.

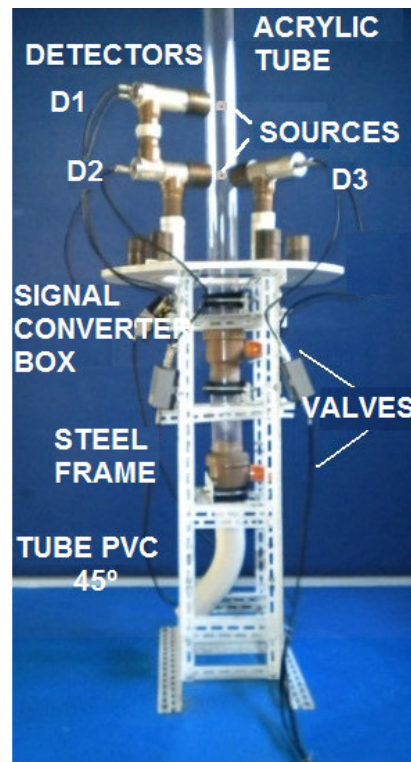

Figure 1: Experimental unit. [1]

cross-correlation function (CCF), with the correlation coefficient describing the temporal dependence between the detectors, can measure the temporal dependence between two random signals. As pellets move inside the pipe, the signal registered by the detectors varies due the gamma photons scattered by changes in density.

Thus, the signal of D2, $y(t)$, the CCF allows to describe how this signal is affected by interference from physical processes that are occurring during the shift of the solid phase, when compared to a signal recorded by the first detector, $x(t)$. The Equation 1, known as Convolution Equation, gives the CCF:

$$R_{xy} = \frac{1}{T} \int_0^T x(t-\tau) \cdot y(t) dt \quad (1)$$

Where:

- R_{xy} - Cross Correlation function;
- T - Total time;
- τ - Transient Time between x(t) and y(t).

The function R_{xy} is a distribution function and is common to use the normalized value called correlation coefficient, given by Equation 2:

$$\rho_{xy}(t) = \frac{R_{xy}(t)}{\sqrt{R_{xx}(0) \cdot R_{yy}(0)}} \quad (2)$$

Where:

- $R_{xx}(0)$ - Autocorrelation function for x(0);
- $R_{yy}(0)$ - Autocorrelation function for y(0).

A particular advantage of this methodology is that any external signal present does not interfere with the measurement of the CCF, since there is no correlation between random signals, the CCF will be null in this situation.

The transient time between the signals recorded by detectors D1 and D2 is given by the maximum of the coefficient of correlation called Transient Time, τ , between x (t) and y (t). So if "L" is the average distance between the detectors D1 and D2, then pellet velocity (v) is given by the Equation 3:

$$V = \frac{L}{t_{\max}} = \frac{L}{\tau} \quad (3)$$

There are several methods for calculating the cross-correlation function, among them, Fast Fourier Transform (FFT). In the frequency domain the signals from D1 and D2 are:

$$\begin{aligned} \text{FFT}[x(t)] &= X(f) = \text{Real } X(f) + \text{Imag } X(f) \\ \text{FFT}[y(t)] &= Y(f) = \text{Real } Y(f) + \text{Imag } Y(f) \end{aligned} \quad (4)$$

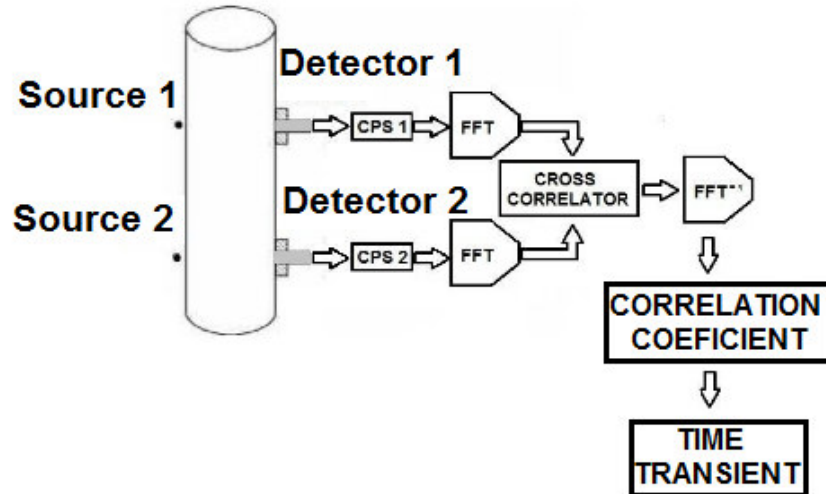

Figure 2: Correlator flow meter [1]

Applying inverse Fourier Transform, then coefficient of correlation is given by:

$$R_{xy}(t) = F^{-1}[X(f) \otimes Y(f)] \quad (5)$$

And the time transient is calculated as the first statistical moment of $R_{xy}(t)$:

$$\tau = \frac{\int_0^T t \cdot R_{xy}(t) dt}{\int_0^T R_{xy}(t) dt} \quad (6)$$

The method for obtaining data uses Fourier Transform and the concept is simple: the mathematical fundamental is the way in which values of the input signal registered by detector D1 is affect future values of the output signal in detector D2. The advantage of cross-correlation technique is that any spurious signals present as interference on the signs from the detectors is strongly rejected because there is no correlation between electronic noise and the signals due the gamma photons registered by the detectors. Figure 2 shows our correlator flowmeter.

To calculate the correlation coefficient was employed the program "CROSSCOR" developed by the research group. This program uses the direct method to calculate the cross-correlation using a fixed data window equal to 0.28 s and in all experiments the data were collected using an time interval equal to 0.05 s for both detectors.

4. RESULTS AND DISCUSSION

The test described below was used the specimens called P2: 10% polystyrene + 10% + 80% cement plaster, with 2 cm diameter.



Figure 3: P2 specimens. [1]

The pellets were released in free fall (with null initial velocity) and using water as liquid phase. The pellets described irregular trajectories and, it was noted that there was interaction between them (collisions), highlighting the complexity of the real movement inside the pipeline.

A situation that occurs frequently during the operation of a pipeline is the formation of a moving bed, this occurs when the speed is slightly greater than the sedimentation velocity, heavier pellets move towards the bottom of the duct and move as dunes. The lighter pellets are carried to the top of pipe and move with higher speed. If this situation persists, the fluid will act as being made up of symmetrical portions moving with different velocities.

This scenario was simulated by releasing a set of 9 P2 pellets and 2000 acrylic spheres with 7 mm diameter. The results of the signals generated by the detectors are presented in Figure 4, where the peaks between $t = 25.0$ s and $t = 33.0$ s demonstrate the P2 pellets pass registration. However, the movement of 2000 acrylic spheres is not evidenced with a typical structure in the curve, because the Attenuation coefficient of acrylic (polymethylmethacrylate PMMA) is close to that of water, so the interaction of gamma photons in two ways is very similar.

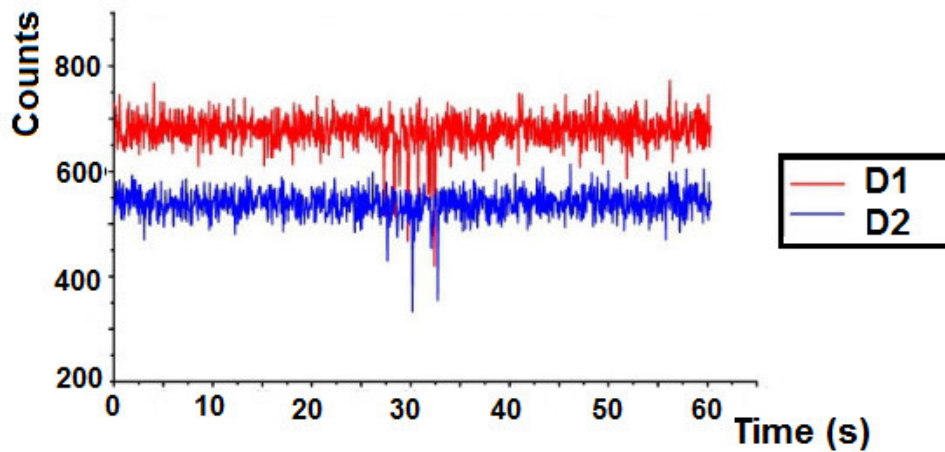

Figure 4: Passage of mobile bed and P2 pellets between D1 and D2. [1]

Due to the moving dune the P2 pellets moved in three distinct groups, evidenced by the presence of peaks with lower intensities ($t = 27.5$ s, $t = 30.0$ s and $t = 32.5$ s), For the moving bed, the signal recorded by detectors is like a noise.

As can be seen in Figure 5, the correlation coefficient between D1 and D2 presents an maximum in $t = 0.963$ s, corresponding to passage of P2 pellets. Between $t = 0.94$ s and $t = 4.63$ s appears what is called "band structure", which corresponds to the slow movement of mobile beds portions.

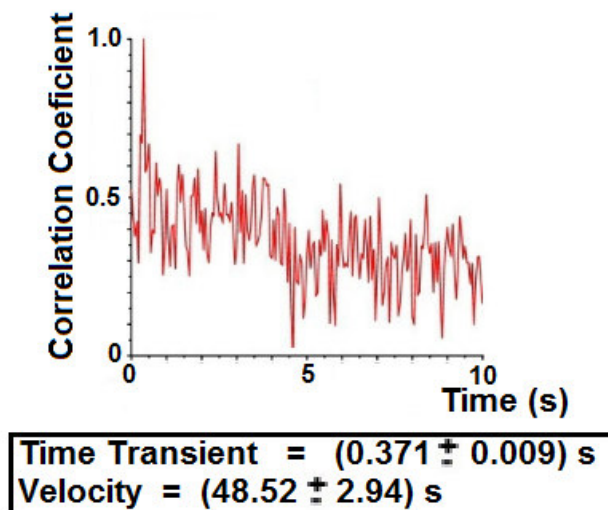

Figure 5: Correlation coefficient of mobile bed and P2 pellets. [1]

5. CONCLUSIONS

The results demonstrated a significant advantage in use cross-correlation from signals registered by two scintillators detectors to measure transient time and study the flow of solid pellets moving inside a pipe: cross-correlation function measures the signals from gamma attenuation by the pellets and rejects both signals from electrical noise or signals from spurious gamma scattered by the system.

As shown, the technique of Cross Correlation function using Fourier Transform allowed to measure the get results with 1% of uncertainty.

Finally, it was difficulty to measure the velocity of small pellets (< 3 mm), this is due the distance between the detectors and the geometric arrangement between the source and the detector. This will be object of future work

REFERENCES

1. SICILIANO, U. C. C. S., **MONITORAMENTO DE VAZÃO EM UNIDADES DE HIDROTRANSPORTE DE MINÉRIO EMPREGANDO ESPALHAMENTO GAMA E TÉCNICA DE “CROSS-CORRELATION”**, Engº Metalúrgico, Universidade Federal do Rio de Janeiro, Rio de Janeiro, Rio de Janeiro, Brasil, 2014.
2. Eleanor Chu, **Discrete and Continuous Fourier Transforms: Analysis, Applications and Fast Algorithms**, CRC Press, (2008).
3. Timothy J. Baile , Mark Fernald, "**Method and Apparatus for Measuring a Parameter of Fluid Flowing Within a Pipe**", U.S. Patent Application Publication, N. 2007/0022824 A1, (2007).
4. B. Le Guennec , M. Alquier, "**Analysis of a horizontal Solid-Liquid Pipe Flow by Cross-Correlation Method**", Int. J. Multiphase Flow, Vol 4 pp 511-521, (1978).
5. Asa Sundqvist, Anders Sellgren, Graeme Addie, "**Slurry Pipeline Friction Losses for Coarse and High Density Industrial Products**", Powder Technology., Vol 89 pp 19-28, (1996).