



**Thank you for downloading this document from the RMIT Research Repository.**

The RMIT Research Repository is an open access database showcasing the research outputs of RMIT University researchers.

RMIT Research Repository: <http://researchbank.rmit.edu.au/>

**Citation:**

Date, A, Alam, F, Khaghani, A and Akbarzadeh, A 2012, 'Investigate the potential of using trilateral flash cycle for combined desalination and power generation integrated with salinity gradient solar ponds', *Procedia Engineering*, vol. 49, pp. 42-49.

See this record in the RMIT Research Repository at:

<http://researchbank.rmit.edu.au/view/rmit:17706>

Version: Published Version

Copyright Statement: © The Authors

Link to Published Version:

<http://dx.doi.org/10.1016/j.proeng.2012.10.110>

**PLEASE DO NOT REMOVE THIS PAGE**

This paper is available under a creative commons attribution noncommercial  
noderivatives 3.0 unported license. For the terms of the license please go to:  
<http://creativecommons.org/licenses/by-nc-nd/3.0/>

Evolving Energy-IEF International Energy Congress (IEF-IEC2012)

## Investigate the potential of using trilateral flash cycle for combined desalination and power generation integrated with salinity gradient solar ponds

Abhijit Date\*, Firoz Alam, Anna Khaghani and Aliakbar Akbarzadeh

*Energy CARE Group, School of Aerospace, Mechanical and Manufacturing Engineering, GPO Box 2476, Melbourne 3001, Australia*

**Elsevier use only:** Revised 30<sup>th</sup> August 2012; accepted 31<sup>st</sup> August 2012

### Abstract

This paper examines the concept of using the trilateral flash cycle for combined desalination and power generation from salinity gradient solar ponds in the salt affected areas of Australia. Firstly causes of the high salinity in the ground waters of northern Victoria, Australia are discussed. Existing salinity mitigation schemes are introduced and the integration of solar ponds with those schemes is discussed. Further the basic working principle of the combined desalination and power generation system is discussed followed by discussion of the governing equation and thermodynamics used in the desalination and power generation process. Experimental setup and the test results are briefly explained to give an idea of the performance of the present system. Later it is shown how a combined desalination and power generation system can be coupled with a solar pond for fresh water production and power generation. Following the introduction of this concept the preliminary design is presented for a demonstration of a combined desalination and power plant coupled with a solar pond of 10000m<sup>2</sup> surface area and a depth of 3 m located in the northern region of Victoria. The performance, including fresh water output, power output and efficiency of the proposed plant operating in northern Victoria is analysed and the results are discussed.

© 2012 The Authors. Published by Elsevier Ltd. Selection and/or peer-review under responsibility of the International Energy Foundation

*Keywords:* Trilateral flash cycle; desalination; power generation; solar ponds

### Nomenclature

$A_{exit}$	Area (m <sup>2</sup> )
$h_i$	Specific enthalpy of hot water at inlet of the turbine (kJ/kg)
$h_o$	Specific enthalpy of mixture at nozzle exit of the turbine (kJ/kg)
$\dot{m}$	Mass flow rate (kg/s)
$N$	Rotational speed (rpm)
$\dot{Q}_H$	Rate of heat supply (J/s)
$R$	Turbine radius (m)
$T$	Temperature (°C)

\* Corresponding author.

E-mail address: [abhijit.date@rmit.edu.au](mailto:abhijit.date@rmit.edu.au)

$T_h$	Temperature of heat source (°C)
$T_c$	Temperature of condenser (°C)
$\eta_{heatengine}$	Overall efficiency of the system
$\eta_{Turbine}$	Turbine efficiency
$\rho$	Density of liquid water (kg/m <sup>3</sup> )
$\omega$	Angular velocity (rad/s)

## 1. Introduction

For reasons which will be explained later and which are mostly related to human exploitation of nature, large areas of salt affected land have been created in the northern parts of the State of Victoria in Australia. Because of the low availability of fresh water, the land in the salt affected areas does not generally have much agricultural value. The salinity of the water in the aquifer of the affected region ranges from several hundred to several thousands of ppm (25,000–30,000 ppm in the area of this study) and the water table is only a few meters below the ground surface. This offers an almost infinite source of low saline water for construction and maintenance of salinity gradient solar ponds (referred to henceforth as solar ponds). Also, land in this region is relatively flat and receives sunshine at a yearly average rate of approximately 19 MJ/m<sup>2</sup>/day on horizontal surfaces. These characteristics have been identified as providing favourable conditions for construction and operation of solar ponds as sources of industrial process heat for the salt industry which operates in northern Victoria [1]. On this basis a 3000 m<sup>2</sup> solar pond was constructed in Pyramid Hill as part of the facilities of the Pyramid Salt Company in northern Victoria [2]. The pond was commissioned in June 2001 and reached a temperature of 55 °C in February 2002. It has the capability of producing a minimum of 50 kW heat on a continuous basis. The heat produced has been used for salt drying by the Pyramid Salt Company. The Pyramid Hill solar pond has been successful in demonstrating how easy it is to operate and maintain a pond of this nature as part of a salt works.

Of particular interest in the region is the generation of electricity using solar pond technology as an integral part of a salt works. Because of the compatibility and ease of integration of solar ponds with such salt production facilities, it appears probable that solar ponds can also provide heat for some kind of heat engine to produce renewable power [3].

Through several demonstration projects, organic fluid Rankine cycle engines (ORC) and solar ponds have been successfully combined. Incorporating an air turbine into a solar chimney for power production has also been examined. In this paper, attempts are made to investigate the use of a chimney with a turbine as a potentially simple alternative to ORC engines and as a compatible energy converter for integration with solar ponds for production of power in salt affected areas of Victoria. The main purpose of this paper is consideration and preliminary examination of the feasibility of combining in salt affected areas a tower containing an air turbine with a solar pond. Without considering cost issues at this stage, a tower (including the internal air turbine) seems to be a less complex and simpler system to be combined with a solar pond than use of ORC engines [4]. In addition it can be anticipated that the construction of the tower and the related civil work will generate local employment which can be of prime importance in socially and economically depressed environments affected by salinity. However, as will be shown later, unless the tower is very tall, the overall efficiency of conversion of solar radiation to mechanical or electrical power using a combination of chimney and solar pond is expected to be low.

## 2. Solar pond basics and Causes of salinity, existing salinity mitigation schemes and the integration of solar ponds into salt works

Solar ponds are large bodies of water which act as solar collectors. In these ponds water is heavier at greater depths than at the surface because of higher salt concentration. As a result the natural convection which exists in freshwater ponds is suppressed in solar ponds. Consequently in solar ponds, solar radiation reaching and absorbed at the lower region can cause its temperature to rise substantially. The temperature difference which is created between the top and the bottom of a solar pond can be as high as 60 °C. The collected and stored heat can be extracted and used for industrial process heat, space heating, and even power generation [3].

Extensive research has also been carried out to utilize the thermal energy produced by solar ponds to produce electrical power. The best showcase for such power generation was a project near the Dead Sea wherein, using a Rankine cycle heat engine, 5 MW electrical power was produced from a 210,000 m<sup>2</sup> solar pond having a depth of 4.5 m [1]. In El Paso Texas a 100 kW Rankine cycle turbine was used to generate electrical power from a 3700 square meter solar pond and the power was fed to the local electricity grid [5].

Following European settlement of Australia, agricultural and other development has led to a major change in the vegetation of large parts of the land surface. Over large areas, native deep-rooted trees have been replaced by shallow-

rooted pastures and legume crops. These shallow-rooted plants use less water than the trees, and thus allow more water to flow down through the soil into the groundwater system. In irrigation areas, water is diverted from rivers onto the land, thus increasing the volume of water reaching the groundwater system. Consequently land uses in Australia over the last two centuries have significantly changed the groundwater movement and storage patterns. Over time the groundwater level has risen, bringing to the surface salts previously stored deep in the soil profile. This process has resulted in salts accumulating in surface soils, inhibiting or preventing plant growth. A number of salt interception schemes involve the use of evaporation basins, into which saline groundwater is pumped. Solar radiation evaporates the water, leaving the salt behind. There are currently approximately a hundred evaporation basins in use in the Murray Darling Basin region of the State of Victoria, ranging in size from 3 to 2500 hectares with depths ranging from 0.3 to 5 m.

Solar ponds could be incorporated into evaporation basins to produce heat and/or electricity and/or fresh water from otherwise unproductive land. If evaporation ponds are established in a chain such as in a “salt work”, the first few ponds in the chain provide ideal opportunities for creating solar ponds. These first ponds are of low salinity, with a flow-through of water to maintain the required low surface salinity of a solar pond. The final pond in the chain can be the source of highly saline brine (bittern, a by-product of salt works and mainly magnesium chloride) to maintain the salinity of the bottom of the solar pond.

### 3. Basic working principle of the Combined Desalination and Power generation system (CDP)

The combined desalination and power generation system referred as CDP in the paper makes use of trilateral flash cycle. As shown in the schematic of CDP in Fig. 1, hot saline water enters into a flashing tank through a radially outward flow two-phase reaction turbine. Initially the pressure inside the flashing tank is between 5-6kPa absolute, this corresponds to water saturation temperature of about 32-36°C. Cooling water inlet temperature to the condenser is maintained between (18-23°C). The hot (>60°C) saline water flash evaporates in the divergent nozzle inside the reaction turbine and exits the turbine radially at a high velocity in form of liquid-vapour mixture. The reaction force of this mixture makes the turbine rotate at very high speed; an electric generator connected to this turbine to produce power. The vapour part of the mixture flows to the condenser, where it is condensed and removed from the system as fresh water. The liquid part of the mixture is at higher salinity, which falls to the bottom of the flashing tank and is continuously removed from the flashing tank.

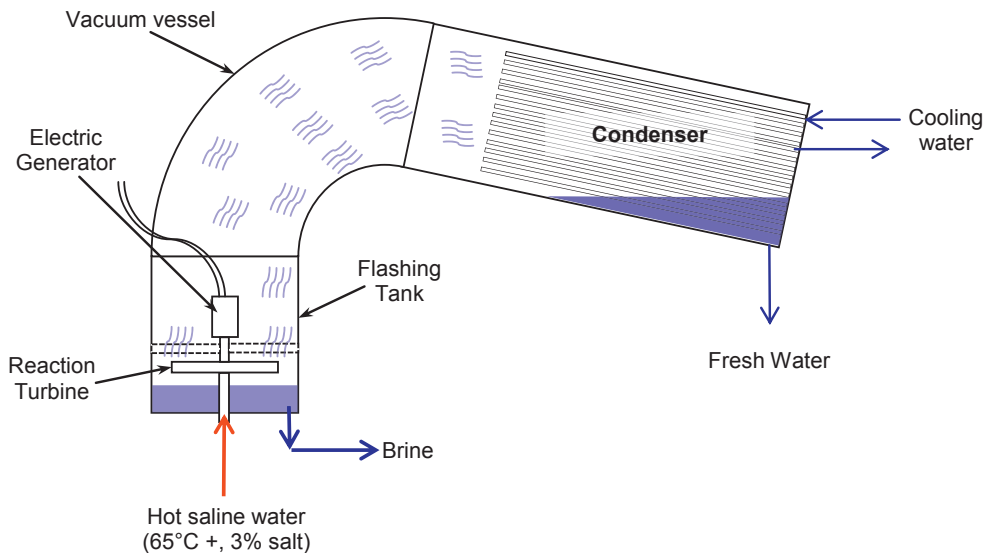

Fig. 1 Schematic showing the principle of the CDP system

### 4. Governing equations for a simple reaction flashing turbine

Considering the thermodynamic process that happens in the turbine with one inlet and two exit nozzle as shown in Fig. 22, the energy balance equation can be written for the mentioned control volume.

$$\dot{m} h_i + \frac{1}{2} \dot{m} V_i^2 + \rho g z_i = \dot{m} h_o + \frac{1}{2} \dot{m} V_o^2 + \rho g z_o + \dot{Q} + \dot{W} \tag{1}$$

Because of the very slow velocity in the inlet in comparison with the exit velocity,  $V_i$  can be omitted from the equation. In addition, it is assumed that both the inlet and exit are at same level and so the potential head is neglected. It is assumed that there is not heat lost to the surroundings as the turbine is in high vacuum environment so  $\dot{Q} = 0$ . Also in the following equation the outlet velocity is called as absolute velocity of the fluid leaving the turbine  $V_o = V_a$ . For the turbine to have maximum efficiency it is expected that the absolute velocity of the fluid leaving the turbine be minimum, i.e. kinetic energy lost with the exiting fluid is minimum.

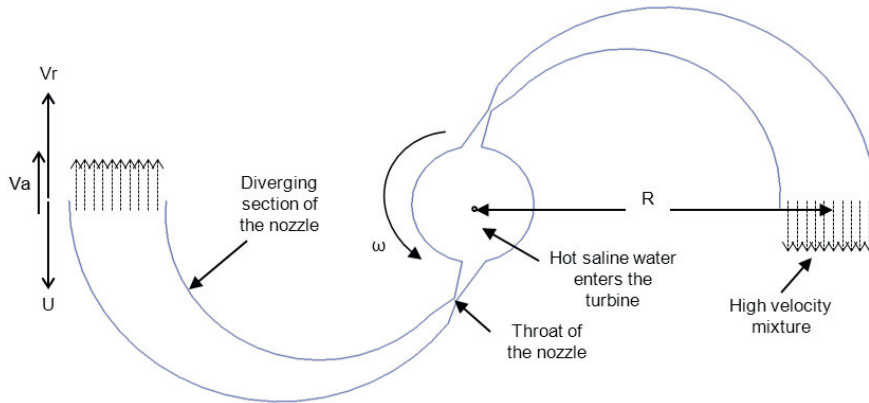

Fig. 2 Schematic of the outward radial flow reaction turbine rotor used in CDP

$$\dot{m}(h_i - h_o) = \frac{1}{2} \dot{m} V_a^2 + \dot{W} \tag{2}$$

In equation 2 the mechanical power output from the turbine  $\dot{W}$  is considered to be a function of rotational torque and the angular velocity and is shown by following equations.

$$\dot{W} = T\omega = \dot{m} V_a R \omega \tag{3}$$

$$V_a = V_r - R\omega \tag{4}$$

$$\dot{W} = \dot{m} R \omega \left[ \sqrt{R^2 \omega^2 + 2(h_i - h_o)} - R\omega \right] \tag{5}$$

Initially when the turbine is stationary, the mass flow rate and hence the relative velocity of the fluid exiting the turbine is only dependent on the change in enthalpy between inlet and exit. But as the turbine starts to rotate the mass flow rate increases due to the centrifugal pumping effect and hence the optimum exit nozzle area changes with angular velocity of the simple reaction two phase turbine as shown by the following equations.

$$V_r = \frac{\dot{G}_o \dot{m}}{\dot{m} \dot{G}_o} \sqrt{R^2 \omega^2 + 2(h_i - h_o)} = \sqrt{R^2 \omega^2 + 2(h_i - h_o)} \tag{6}$$

$$\dot{m} = \rho_o A V_r = A V_r \frac{1}{\dot{G}_o} \Rightarrow A = \frac{\dot{m} \dot{G}_o}{V_r} \tag{7}$$

$$A_{exit} = \frac{m \mathcal{G}_o}{\sqrt{R^2 \omega^2 + 2(h_i - h_o)}} \quad (8)$$

The overall efficiency is represented as the mechanical power output divided by the total thermal energy input to the CDP system. The mechanical efficiency is defined as the ratio of mechanical power divided by the rate of change of thermal energy between inlet and exit of the turbine shown by following equations.

$$\eta_{heat\ engine} = \frac{Power}{\dot{Q}_H} = \frac{W}{\dot{Q}_H} = \frac{m R \omega \left[ \sqrt{R^2 \omega^2 + 2(h_i - h_o)} - R \omega \right]}{m C_p (T_i - T_o)} \quad (9)$$

$$\eta_{turbine} = \frac{T \omega}{m \Delta h} = \frac{T \omega}{T \omega + \frac{1}{2} m V_a^2} \quad (10)$$

## 5. Experimental set-up and test results

Fig. 33 show the block diagram of the CDP and its data acquisition system. Important test parameters, such as feed water flow rate and temperature, fresh water production rate, and the vacuum pressure inside the chamber are measured through different transducers. Proper load is selected for generating the electrical power, which is in the form of an electrical globe box that contains a series of light globes. The experimental measurements are recorded using a data logger for performance analysis.

Fig. 4 shows the stage 5 CDP unit at RMIT University that was used for preliminary experiments at 95°C and total thermal input of around 50kW. The flashing chamber has O-ring seals and can hold vacuum of 5kPa absolute. Tap water was used for the initial tests to save time and prevent having to deal with the scaling effect with saline water.

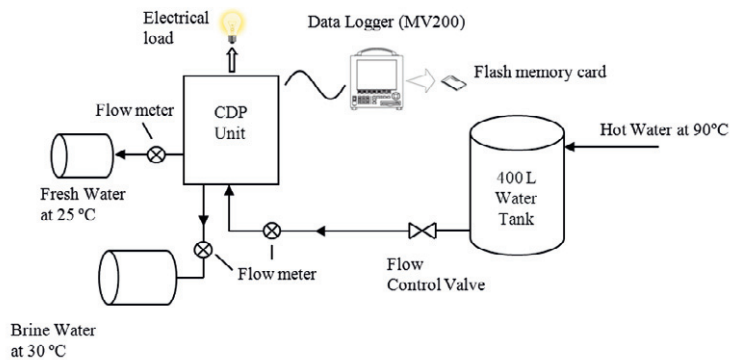

Fig. 3 Block diagram CDP and its data acquisition system



Fig. 4 Flashing tank at RMIT University

Fig. 5 A shows the simple reaction flash turbine that has been used in the stage 5 CDP system. This turbine design has been influenced by the work of Fabris [6] and Zhao [7] and has following significant advantages. Firstly, the separation force that causes the slip loss between the liquid and vapour phases is dramatically reduced. This is achieved by profile curving of the nozzles as described by Fabris [6]. Secondly, the new design is expected to have a drastic reduction in abruptness of the flashing process. 5 B shows the condenser that is made out of 19mm diameter and 18m length copper tube wound in coil. The condensate is collected in a tank that sits under the flashing chamber and is extracted from the tanks using very high suction pumps.



A. Novel Disk Reaction Turbine



B. Condenser coil in the CDP system

Fig. 5 A two-phase reaction turbine and condensing coil

The test results show that CDP can produce 400W of electrical power and estimated 500W mechanical power at around 5000 rpm, when supplied with hot water at temperature of 95°C and a mass flow rate of 0.2kg/s. At the same time the flashing tank is maintained at 5.5kPa absolute pressure which corresponds to the saturation temperature of 34.6°C. The test results show a fresh water recovery rate of 11%, i.e. 0.022kg/s or around 2m<sup>3</sup>/day. From the test results it was estimated that the isentropic efficiency of the present simple reaction flash turbine (two-phase nozzle) is about 10% of ideal isentropic. The total thermal power supplied to the system is about 50kW, therefore the overall efficiency of the system is estimated to be only 1% which is very low and need to be improved by further research on the optimisation of the two-phase flow nozzles.



## 6. CDP with solar pond concept and performance

Fig. 6 shows the CDP system coupled with a solar pond. The saline ground water from the northern Victoria, Australia is gradually heated using the heat from the solar pond to  $85^{\circ}\text{C}$  in peak summer when the ambient temperature in this region goes up to  $35^{\circ}\text{C}$ . The air in this area is very dry and hence the temperature of the top layer of solar pond is very close to the wet bulb temperature which is around  $28^{\circ}\text{C}$  -  $30^{\circ}\text{C}$ . This cold water from the top of the solar pond is used for cooling water in the condenser.

A  $10000\text{m}^2$  solar pond with an efficiency of 25% located in the northern Victoria, Australia can achieve maximum temperature of  $85^{\circ}\text{C}$  in summer and a minimum temperature of  $65^{\circ}\text{C}$  in winter. The amount of average daily heat extraction possible from a  $10000\text{m}^2$  solar pond during summer is about  $580\text{kW}$  and during winter is about  $280\text{kW}$ . In summer the average daily temperatures of the top layer (UCZ) of solar pond is about  $30^{\circ}\text{C}$  and in winter it's  $20^{\circ}\text{C}$ . As estimated from the experimental test results the isentropic efficiency of the present two-phase flow turbine is about 10% and further research is being carried out to improve the efficiency with an expected increase in two-phase nozzle isentropic efficiency to 25%. These two efficiency points have been considered for as achievable for the prediction of the power and fresh water output from the  $10000\text{m}^2$  solar pond and shown in Fig. 7. The average power production of the CDP-solar pond plant with the present turbine design during summer will be  $4.5\text{kW}$  and during winter will be  $2.5\text{kW}$ . And with the fresh water recovery rate of 11% this plant can produce about  $24\text{m}^3/\text{day}$  of fresh water during summer and  $14\text{m}^3/\text{day}$  during winter. Once an improved turbine has been designed then the power production will significantly increase as shown in Fig. 7.

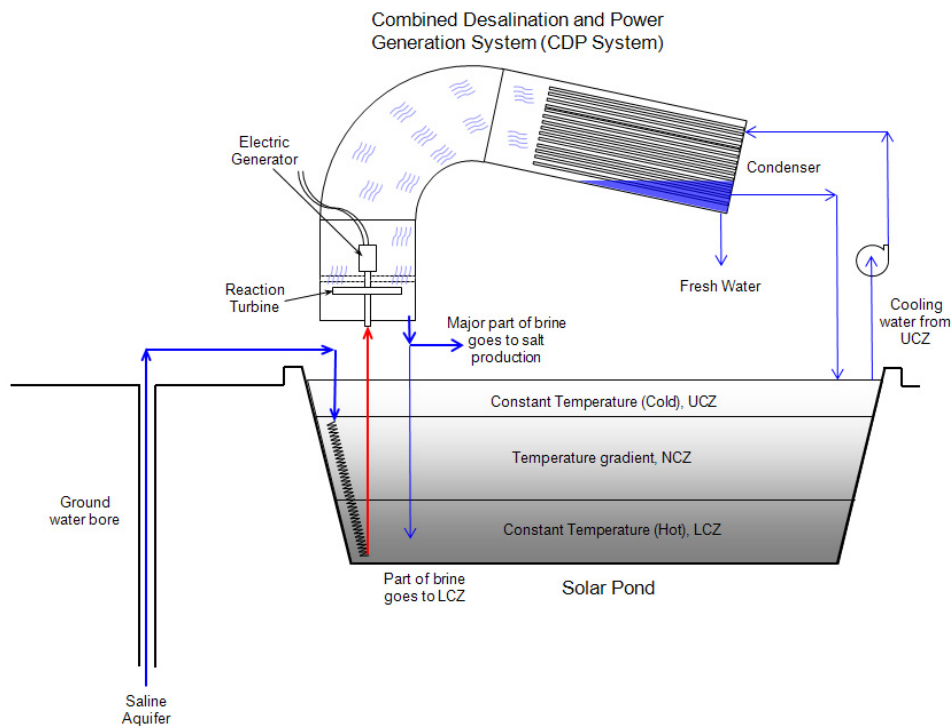

Fig. 6 Schematic showing the concept design of the solar pond coupled with CDP system

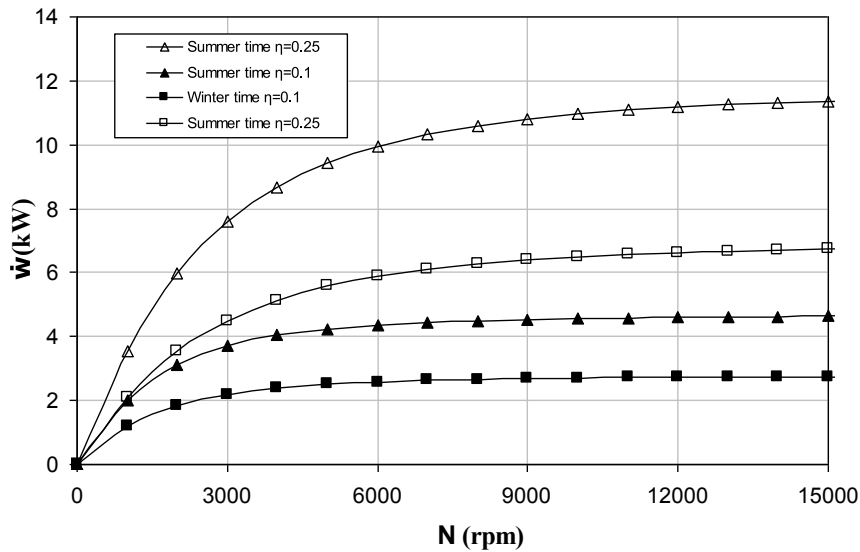

Fig. 7 Power and fresh water prediction for the solar pond coupled CDP

## 7. Conclusion

According to our calculation and preliminary experiments on the CDP system, it can produce fair amount of power and fresh water from low temperature renewable energy heat source like a solar pond. The concept has been confirmed by the experiment. The experimental results show the present simple reaction flash turbine is only 0.1 efficient as compared with ideal isentropic turbine. This estimation is best on the power measurement, but the fresh water production rate shows that enough vapour is produced to represent flashing efficiencies of up to 0.95 of an ideal isentropic. This shows that there is some liquid that evaporates after it leaves the turbine and hence none of that thermal energy is available for conversion to kinetic energy and in turn to mechanical energy. As for the concept of CDP-Solar Pond plant, it is very practical to use CDP to prevent the saline water deteriorating the farm land in Australia.

## References

1. Fabris, G., *Two phase flow turbine for cogeneration, geothermal, solar and other applications*. FAS Engineering, May 2006.
2. Zhao, Y., Akbarzadeh, A., and Andrews, J., *Combined Water Desalination and Power Generation Using a Salinity Gradient Solar Pond as a Renewable Energy Source*. in *ISES World Congress 2007* Springer Berlin Heidelberg.
3. Smith, I.K. *Development of the trilateral flash cycle system*. in *Proceedings of the Institution of Mechanical Engineers* 1994.
4. Zuo, L., Zheng, Y., Li, Z., Sha, Y., *Solar chimneys integrated with sea water desalination*. *Desalination*, 2011. **276**(1–3): p. 207-213.
5. Hung, T.C., Shai, T.Y., and Wang, S.K., *review of organic rankine cycles (ORCs) for the recovery of low-grade waste heat*. *Energy*, 1997. **22**(7): p. 661-667.
6. Fabris, G., *Two-phase reaction turbine*. 1993: United States.
7. Zhao, Y., Akbarzadeh, A., and Andrews, J., *Simultaneous desalination and power generation using solar energy*. *Renewable Energy*, 2009. **34**(2): p. 401-408.