

An E-Model Implementation for VoIP QoS across a Hybrid UMTS Network

**A thesis submitted in fulfilment
of the requirements for the degree of**

Master of Engineering in Computer Engineering

Jianguo Cao

BSc, BEng

School of Electrical and Computer Engineering

RMIT University

Melbourne, Australia

March 2009

Preface

Abstract

Voice over Internet Protocol (VoIP) provides a new telephony approach where the voice traffic passes over Internet Protocol shared traffic networks. VoIP is a significant application of the converged network principle. The research aim is to model VoIP over a hybrid Universal Mobile Telecommunications System (UMTS) network and to identify an improved approach to applying the ITU-T Recommendation G.107 (E-Model) to understand possible Quality of Service (QoS) outcomes for the hybrid UMTS network.

This research included Modeling the hybrid UMTS network and carrying out simulations of different traffic types transmitted over the network. The traffic characteristics were analysed and compared with results from the literature. VoIP traffic was modelled over the hybrid UMTS network and the VoIP traffic was generated to represent different loads on the network from light to medium and heavy VoIP traffic.

The VoIP over hybrid UMTS network traffic results were characterized and used in conjunction with the E-Model to identify VoIP QoS outcomes. The E-Model technique was implemented and results achieved were compared with results for other network types highlighted in the literature.

The research identified an approach that permits accurate Modeling of VoIP QoS over a hybrid UMTS network. Accurate results should allow network design to facilitate new approaches to achieving an optimal network implementation for VoIP.

Declaration

I certify that except where due acknowledgement has been made, the work is that of the author alone; the work has not been submitted previously, in whole or in part, to qualify for any other academic award; the content of the thesis is the result of work which has been carried out since the official commencement date of the approved research program; and, any editorial work, paid or unpaid, carried out by a third party is acknowledged; and, ethics procedures and guidelines have been followed.

Jianguo Cao

30 March 2009

Acknowledgement

I wish to express my sincere gratitude to Dr. Mark Gregory, Program Director for Network Engineering from School of Electrical and Computer Engineering for his guidance, encouragement, suggestions and support during the progress of the research and realization of the research. This also extends to all the staff of School of Electrical and Computer Engineering and RMIT University.

Special thanks also go to my wife for all her support and patience through all the time it took to complete this thesis.

Table of Contents

Preface	i
Abstract.....	i
Declaration.....	ii
Acknowledgement	iii
Table of Contents	iv
Table of Figures.....	vii
Table of Tables	x
List of Abbreviations	xi
1 Introduction	1
1.1 Scope	3
1.2 Purpose	4
2 Background.....	6
2.1 UMTS	6
2.1.1 UMTS network architecture	7
2.1.2 Core net work	7
2.1.3 UMTS Terrestrial Radio Access Network (UTRAN)	8
2.1.4 UMTS User Equipment.....	9
2.1.5 UMTS protocol stack	10
2.2 IP network and real-time applications	11
2.2.1 IP networks for real-time applications.....	11
2.2.2 IP networks to support voice	12
2.2.2.1 Bandwidth requirement	13
2.2.2.2 Delay.....	15
2.2.2.3 Jitter	16
2.2.2.4 Reliability	17
2.2.2.5 Interoperability	17
2.2.2.6 Integration with PSTN.....	17
2.3 An overview of VoIP.....	18
2.3.1 An introduction of VoIP Systems.....	18
2.3.2 Importance and benefits of VoIP	19

2.3.3	VoIP architectures	20
2.3.3.1	Infrastructure for Cisco's AVVID	21
2.3.3.2	Applications for Cisco's AVVID	22
2.3.4	VoIP standards and protocols	22
2.3.4.1	H.323 standard.....	23
2.3.4.2	Session Initiated Protocol (SIP) standard	27
2.3.4.3	RTP and RTCP	30
2.4	Quality of Service (QoS) in VoIP	33
2.4.1	Mean Opinion Score (MOS)	33
2.4.2	Delay.....	33
2.4.3	Jitter	34
2.4.4	Packet loss	35
2.5	E-Model	37
2.5.1	E-Model algorithm	37
2.5.2	E-Model and MOS	38
2.5.3	E-Model parameters	38
2.6	Chapter summary.....	40
3	Objectives	41
3.1	Assumptions	42
3.2	Research limitations	43
4	Experimental and Theoretic Work Completed.....	44
4.1	VoIP over hybrid UMTS modeling	44
4.1.1	Opnet Modeler simulation environment.....	44
4.1.2	Hybrid UMTS network Modeling	49
4.2	VoIP over Hybrid UMTS simulation	57
4.2.1	Configure the simulation	57
4.2.2	Profiles configuration	61
4.2.3	Application deployment	64
4.2.4	Running the simulation.....	67
4.3	E-model implementation	68
4.3.1	Basic signal-to-noise ratio (SNR).....	70
4.3.2	Simultaneous impairment factor, Is.....	71

4.3.3	Delay impairment factor, Id.....	73
4.3.4	Effective Equipment Impairment Factor, Ie-eff	73
5	Results and Analysis.....	76
5.1	End-to-end delay results	76
5.2	E-Model R factor results.....	79
5.3	Results Analysis	81
6	Conclusions	85
6.1	Research review.....	85
6.2	Thesis Summary	86
6.3	Research work summary.....	87
6.4	Conclusion.....	88
7	Future Research Work.....	89
8	Reference.....	91
	Appendix A	95

Table of Figures

Figure 2-1: UMTS Architecture	7
Figure 2-2: UTRAN architecture.....	8
Figure 2-3: UMTS protocol stack (PS domain).....	11
Figure 2-4: VoIP Network Connectivity	19
Figure 2-5: Typical IP Telephony Solution	21
Figure 2-6: Basic H.323 Architecture.....	23
Figure 2-7: The H.323 suite in relation to the OSI model	24
Figure 2-8: A typical H.323 call setup life cycle	26
Figure 2-9: Basic SIP Architecture.....	27
Figure 2-10: SIP protocol stack	28
Figure 2-11: A typical SIP call	29
Figure 2-12: RTP packet structure.....	31
Figure 2-13: MOS rating with packet loss.....	36
Figure 2-14: Effects of Random and Burst Packet Loss.....	36
Figure 4-1: New Project - Project and Scenario names.....	45
Figure 4-2: Start-up Wizard – Initial Topology.....	46
Figure 4-3: Startup Wizard - campus network size	47
Figure 4-4: Start-up Wizard - Select Technology.....	47
Figure 4-5: Start-up Wizard – Summarise.....	48
Figure 4-6: Start-up Wizard - Object Palette.....	49
Figure 4-7: VoIP over hybrid UMTS sketch topology	50
Figure 4-8: Hybrid UMTS Modeling - IP Backbone.....	51
Figure 4-9: Hybrid UMTS Modeling - Core Network	51
Figure 4-10: Hybrid UMTS Modeling - UTRAM added	52

Figure 4-11: Hybrid UMTS Modeling - End users added.....	53
Figure 4-12: Hybrid UMTS Modeling - UMTS parameters configuration for SGSN .	54
Figure 4-13: Hybrid UMTS Modeling - UMTS parameters configuration for UE	54
Figure 4-14: Hybrid UMTS Modeling - connecting to Internet	55
Figure 4-15: Hybrid UMTS Modeling - With IP network connected	56
Figure 4-16: Hybrid UMTS Modeling – Final simulation topology	57
Figure 4-17: Application Definitions - Number of Applications	58
Figure 4-18: Application Definitions - Predefined Applications	59
Figure 4-19: Application Definitions - Voice Application Options	59
Figure 4-20: Application Definitions - Voice settings Table	60
Figure 4-21: Application Definitions	60
Figure 4-22: Profile Definitions - Adding a new profile	61
Figure 4-23: Profile Definitions - Profile time-related attributes	62
Figure 4-24: Profile Definitions - Adding an application into a profile	63
Figure 4-25: Profile Definitions - Choosing the application to be added.....	63
Figure 4-26: Profile Definitions - Application time-related attributes	64
Figure 4-27: Serve supported service configuration.....	65
Figure 4-28: UE1 supported services	65
Figure 4-29: Enabling the SIP Server	66
Figure 4-30: UE0 supported profile.....	66
Figure 4-31: Choose DES Results.....	67
Figure 5-1: Packet loss for G.711	77
Figure 5-2: GSM-FR End-to-end delays	78
Figure 5-3: G729A End-to-end delays	78
Figure 5-4: Packet loss rate	80
Figure 5-5: A Hybrid wireless network for VoIP	83

Figure 5-6: Average MOS values for security combinations 83

Table of Tables

Table 2-1: Algorithms for voice compression and decompression	14
Table 2-2: IP bandwidth requirements for the most common coding algorithms	15
Table 2-3: Codec delay	16
Table 2-4: MOS for common CODECs	33
Table 2-5: Definition of categories of speech transmission quality	38
Table 2-6: E-Model parameters	39
Table 4-1: E-Model Inputs (G.107 Default)	70
Table 4-2: Provisional planning values for the equipment impairment factor, I_e	74
Table 4-3: Provisional planning values for the equipment impairment factor, I_e , and for packet-loss robustness factor, B_{pl}	75
Table 5-1: End-to-end delays	79
Table 5-2: R factor values	80
Table 5-3: MOS values	82

List of Abbreviations

3DES	Triple Data Encryption Algorithm
ACF	Admission Confirm
ADPCM	Adaptive Differential PCM
AES	Advanced Encryption Standard
ARJ	Admission Reject
ATNAC	Australasian Telecommunications Networking and Application Conference
AVVID	Architecture for Voice, Video and Integrated Data
CC	CSRC count
CELP	Code-Excited Linear Prediction
CN	Core Network
CODEC	Compression and decompression
CS	Circuit Switched
Diffserv	Differentiated Services
GGSN	Gateway GPRS Support Node
GK	Gatekeeper
GSM	Global System for Mobile Communications
GW	Gateway
HTTP	HyperText Transfer Protocol

IETF	Internet Engineering Task Force
Intserv	Integrated Services
IP	Internet Protocol
IPsec	Internet Protocol Security
JTAPI	Java Telephony Application Programming Interface
LPC	Linear Predictive Coding
M	Marker
MCU	Multipoint Control Unit
MOS	Mean Opinion Score
MPLS	Multi Protocol Label Switching
MP-MLQ	MultiPulse-MultiLevel Quantization
MSC	Mobile services Switching Centre
P	Padding
PCM	Pulse Code Modulation
PDN	Packet Data Network
PoE	Power over Ethernet
PS	Packet Switched
PT	Payload Type
QoS	Quality of Service
R	Transmission Rating Factor

RAQ	RAS Admission Request
RAS	Registration Admission Status
RCF	Registration Confirm message
RNC	Radio Network Controller
RRJ	Registration Reject message
RRQ	RAS registration request
RTCP	Real-time Transport Control Protocol
RTP	Real-time Transport Protocol
RTP/RTCP	Real Time Protocol/Real Time Control Protocol
SDP	Session Description Protocol
SGSN	Serving GPRS Support Node
SIP	Session Initiated Protocol
SNR	Signal-to-Noise Ratio
TAPI	Telephony Application Programming Interface
TE	Terminal Equipment
UA	User Agents
UAC	User-agent client
UAS	User-agent server
UDP	User Datagram Protocol
UE	User Equipment

UMTS	Universal Mobile Telecommunications System
USIM	UMTS subscriber identity module
UTRAN	Radio Access Network
V	Version
VLR	Visitor Location Register
VoIP	Voice over Internet Protocol
VPN	virtual private network
W-CDMA	Wideband Code Division Multiple Access
X	Extension
XML	EXtensible Markup Language

1 Introduction

In the recent years, Voice over Internet Protocol (VoIP) has matured as a digital voice telephony technology. Uptake in the use of VoIP has increased as commercial solutions become available. Other factors include the decrease in quality differences between existing digital telephony and VoIP and the increase in bandwidth available to commercial and residential customers over which VoIP may be transported.

As a real-time digital application, VoIP requires a transmission system that includes low delay, jitter and packet loss rates to ensure that the Quality of Service (QoS) is acceptable. VoIP systems digitize and transmit analogue voice signals as a stream of packets over a digital data network. Internet Protocol (IP) (Information Sciences Institute, 1981) networks allow each packet to independently find the most efficient path to the intended destination. Packets associated with a single source may take many different paths to the destination when travelling over the network. With the different paths, arrivals will vary greatly due to delays and may be out of sequence or possibly not arrive at all. At the destination, the packets are re-assembled and converted back into the original voice signal.

However, most IP networks today were not designed for real-time, delay-sensitive voice or video traffic (Chandrasekharan et al., 2008). Kobayashi (Kobayashi et al., 2003) describes most IP networks as a best-effort transport system and subsequently there is no guarantee that VoIP speech quality will be equivalent to what is provided by the existing PSTN telephony services.

VoIP QoS mechanisms and application level controls have been developed to overcome some of the problems associated with best-effort IP networks and to maximize VoIP call quality including:

- Over-provisioning bandwidth to avoid congestion;
- Network and traffic monitoring to measure and monitor performance;

-
- Differentiated Services (Diffserv) (Seungchul, 2006), i.e. packet classification, marking and policing to give priority to certain classes of traffic;
 - Integrated Services (Intserv) (Brewer et al., 2006), i.e. the use of signalled QoS to reserve network resources across the network.
 - 802.1p (Hu et al., 2008); and
 - Multi Protocol Label Switching (MPLS) (Ash et al., 2004)

VoIP services in wireless networks, such as UMTS (Oudelaar, 1994), are being progressively implemented. A benefit of VoIP over a wireless IP network is the mobility that is provided to users. Wireless networks have their own characteristics (Varshney and Malloy, 2001) which, together with a real-time applications transmission requirement, provide a challenge when a minimum QoS is required. To address this problem, firstly we need to develop tools to measure and monitor QoS.

The ITU-T's E-Model (ITU-T, 2006) is a technique that provides a prediction of the expected voice call quality. The E-Model takes a wide range of telephony impairments into account, such as the impairment due to low bit-rate coding and one-way delay, and the telephony impairments associated with noise and echo. It can be used to assess the quality of voice calls over wired and wireless networks, based on circuit-switched and packet-switched technology. The E-Model is also useful for quality monitoring purposes, although currently there is no agreed-upon monitoring method for overall voice quality of VoIP (ITU-T, 2004).

The E-Model is based on a mathematical algorithm, with which the individual transmission parameters are transformed into different individual "impairment factors" that are assumed to be additive on a psychological scale. The E-Model algorithm also takes into account the combination effects for those impairments in the connection which occur simultaneously, as well as some masking effects (ITU-T, 2004). The E-Model estimates the relative impairments to voice quality when comparing different network equipment and network designs. It also provides a method to estimate the

subjective Mean Opinion Score (MOS) rating (ITU-T, 2003b) of the voice call quality over the different network environments.

The research presented in this thesis includes analysis of the E-Model as an effective means to measure QoS for VoIP over a hybrid UMTS network. As part of this research work, a paper has been presented in Australasian Telecommunications Networking and Application Conference (ATNAC 2008) (appendix A) which focuses on the relationship between CODEC scheme and end-to-end delay on VoIP calls over a hybrid UMTS network. To facilitate the analysis a simulated hybrid UMTS network was created. The simulation included a UMTS core network connected to a fixed IP network and end users at different points on the networks. The next goal was to analyse the initial simulation results and to modify the model with an implementation of the E-Model to permit QoS to be measured. The results from the modified model were analysed and compared with results from other studies identified during the literature review.

1.1 Scope

The research outcome was to implement the E-Model technique to provide an optimal approach to measure VoIP QoS over a hybrid UMTS network. The research was carried out in several steps:

- To implement the E-Model technique and analyse possible implementation variations,
- To analyse voice call quality over a hybrid UMTS network by simulating the network and applying an E-Model technique, and
- Finally, a discussion of possible future work.

The scope of this research included:

- Background investigation of the current research about VoIP and VoIP QoS over wireless networks

-
- An initial investigation of UMTS networks
 - Detailed research and investigation of the E-Model including:
 - Algorithms
 - Parameters
 - Approach to implementing the E-Model for different network types
 - Implementation of a model using Opnet Modeler Version 14
 - Hybrid UMTS network simulation
 - VoIP application configuration
 - Background traffic configuration
 - Data collection
 - Data analysis
 - Comparison of results with prior research and formulation of an E-Model implementation
 - Comparison with results for other wireless network types
 - Identification of approaches used for network specific E-Model implementations
 - Implementation of an E-Model to VoIP over a hybrid UMTS network
 - Results analysis

1.2 Purpose

The purpose of this research was to investigate VoIP QoS over a hybrid UMTS network and to implement a VoIP QoS measurement approach in this particular network type. The research purpose included the aim to identify a suitable hybrid

UMTS model for VoIP QoS study and the implementation of an E-Model technique to measure VoIP QoS across a hybrid UMTS network.

The research commenced with a literature investigation of key technologies, standards and concepts. The literature review is provided in Chapter 2. Chapter 3 includes a description of the simulation environment and details of the network configuration that was used for the study. The E-Model technique used during the research is described in Chapter 4. The simulation results and comparative analysis with VoIP QoS for other network types is provided in Chapter 5. The research results and conclusions are provided in Chapter 6. Finally, the opportunity for future research is discussed in Chapter 7.

2 Background

This Chapter provides a literature review in the areas of wireless networks, voice services and QoS. The key technologies, standards and concepts that form the basis for the research are reviewed and discussed.

This chapter begins with a description of UMTS wireless networks and discussion of the transmission of real-time connection oriented services over a UMTS network. A description of VoIP technologies and concepts are provided next, including VoIP over wireless networks such as UMTS. Combining UMTS networks and VoIP, the review moves on to considering QoS and how this is measured for wireless networks (Hernandez-Valencia and Chuah, 2000). The E-Model is introduced as a QoS measurement and prediction technique. Finally the use of a network simulation is discussed as a means to achieve an understanding of the operation of a real network.

2.1 UMTS

Universal Mobile Telecommunications System (UMTS) (Mason et al., 1996) is one of the third-generation (3G) cell phone technologies (Proctor, 2003). UMTS is broadly thought as the successor to Global System for Mobile Communications (GSM). It provides more capacity and bandwidth for voice and data services. Most UMTS networks use wideband code division multiple access (W-CDMA) as their underlying air interfaces, so UMTS is also referred as W-CDMA.

The UMTS provides support for both voice and data services (Liers and Mitschele-Thiel, 2005). The following data rates are targets for UMTS (Cisco, 2002):

- 144 kbps—Satellite and rural outdoor
- 384 kbps—Urban outdoor
- 2048 kbps—Indoor and low range outdoor

2.1.1 UMTS network architecture

A UMTS network consists of three domains: Core Network (CN), UMTS Terrestrial Radio Access Network (UTRAN) and User Equipment (UE). Figure 2-1 (Cisco, 2002) illustrates the architecture of a UMTS network.

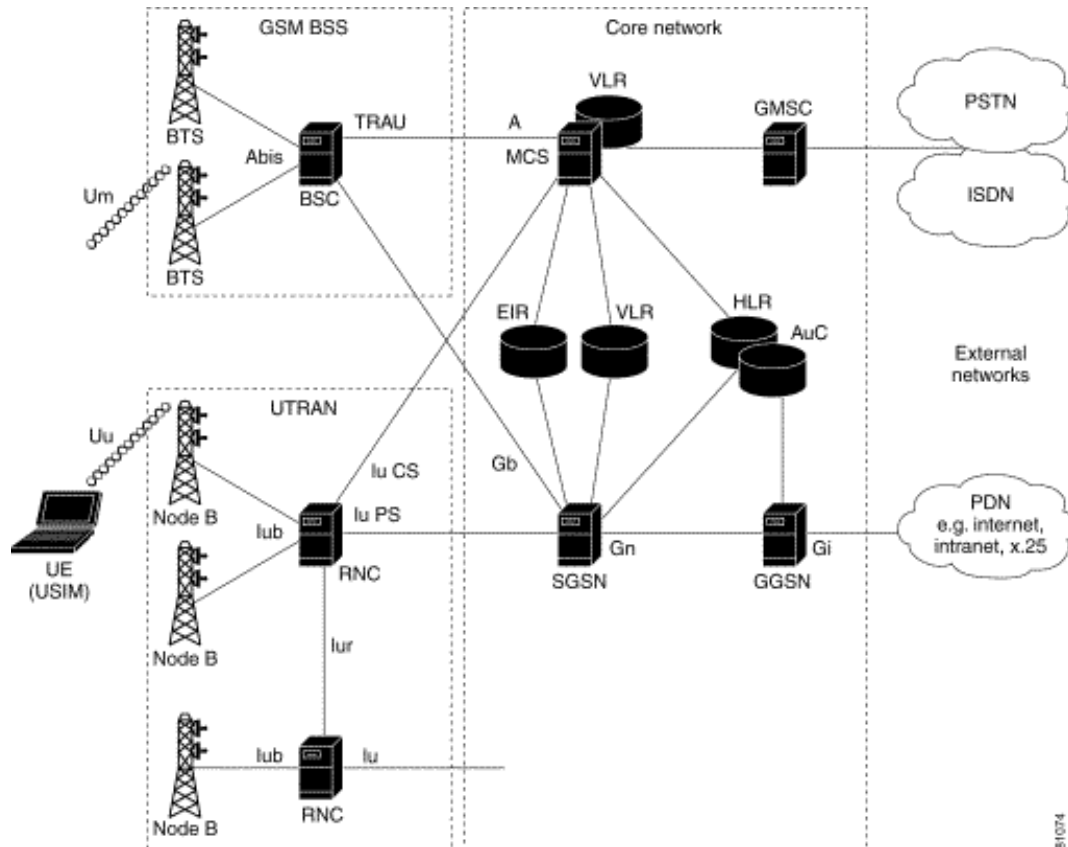

Figure 2-1: UMTS Architecture

2.1.2 Core net work

The UMTS Core Network is based on GSM/GPRS network. The main functions of the core network are to transport, switch and route user traffic (both circuit switched and packet switched traffic).

The UMTS core network is contains circuit switched and packet switched elements. Circuit switched elements include: Mobile services Switching Centre (MSC), Visitor

location register (VLR) and Gateway MSC. Packet switched elements include: Serving GPRS Support Node (SGSN) and Gateway GPRS Support Node (GGSN). Some network elements, like EIR, HLR, VLR and AUC are both circuit switched and packet switched elements (Cisco, 2002).

2.1.3 UMTS Terrestrial Radio Access Network (UTRAN)

The UMTS Terrestrial Radio Access Network (UTRAN) includes two new network elements: the Radio Network Controller (RNC) and Node B. The RNC connects to one or more Node B elements. Each Node B can provide service to multiple cells. Figure 2-2 (Cisco, 2002) illustrates the architecture of the UTRAN domain.

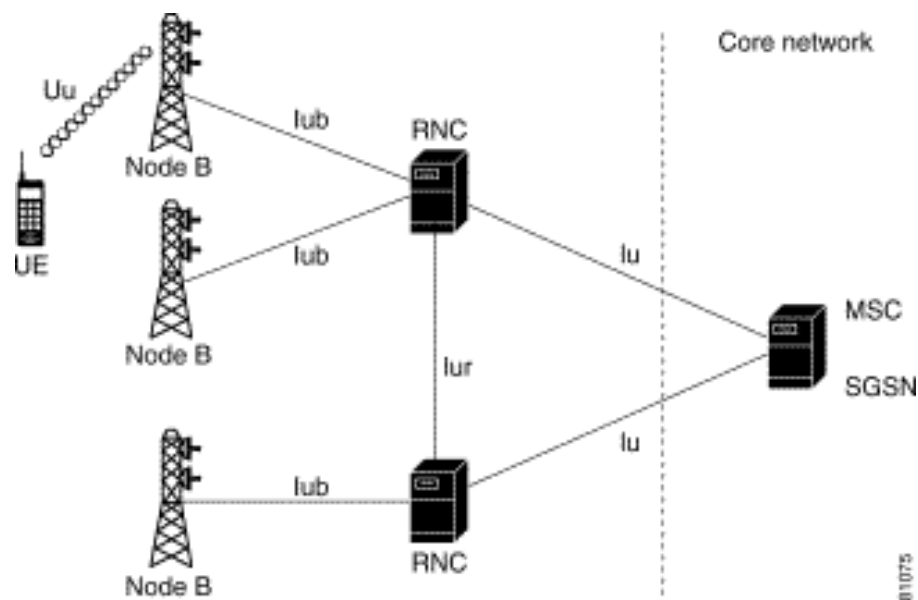

Figure 2-2: UTRAN architecture

The functions of Node-B are (Hawwar et al., 2006):

- Air interface Transmission / Reception
- Modulation / Demodulation
- CDMA Physical Channel coding

-
- Micro Diversity
 - Error Handing
 - Closed loop power control

The functions of RNC are (Matusz et al., 2004):

- Radio Resource Control
- Admission Control
- Channel Allocation
- Power Control Settings
- Handover Control
- Macro Diversity
- Ciphering
- Segmentation / Reassembly
- Broadcast Signalling
- Open Loop Power Control

2.1.4 UMTS User Equipment

The UMTS user equipment (UE) is the mobile equipment with the UMTS subscriber identity module (USIM). The USIM is a card that inserts into the mobile equipment and identifies the subscriber to the core network (Cisco, 2002).

The USIM card has provides the following functions (Cisco, 2002):

- Supports multiple user profiles on the USIM
- Updates USIM information over the air

-
- Provides security functions
 - Provides user authentication
 - Supports inclusion of payment methods
 - Supports secure downloading of new applications

The UMTS UE can operate in one of three modes of operation (Cisco, 2002):

- PS/CS mode—The UE is attached to both the packet-switched (PS) and circuit-switched (CS) domain, and the UE can use both PS and CS services in the same time.
- PS mode—The MS is attached to the PS domain and uses only PS services (but allows CS-like services such as voice over IP).
- CS mode—The MS is attached to the CS domain and uses only CS services.

2.1.5 UMTS protocol stack

In this research project, the PS (packet switch) domain of the UMTS network has the full attention. Being looked at from the upper layer, the PS domain functions like normal IP network (Jin and Kriaras, 2000). Figure 2-3 (Loffelmann, 2000) illustrates a scenario that a UE that established a TCP connection to a Terminal Equipment (TE) connected to an external packet data network (PDN). As TCP and UDP are both running on top of IP, it will be shown the similar protocol stack if UDP was used instead of TCP (Koth et al., 1996). In addition to this, RTP can be implemented to transmit voice (MacKnight et al., 2004).

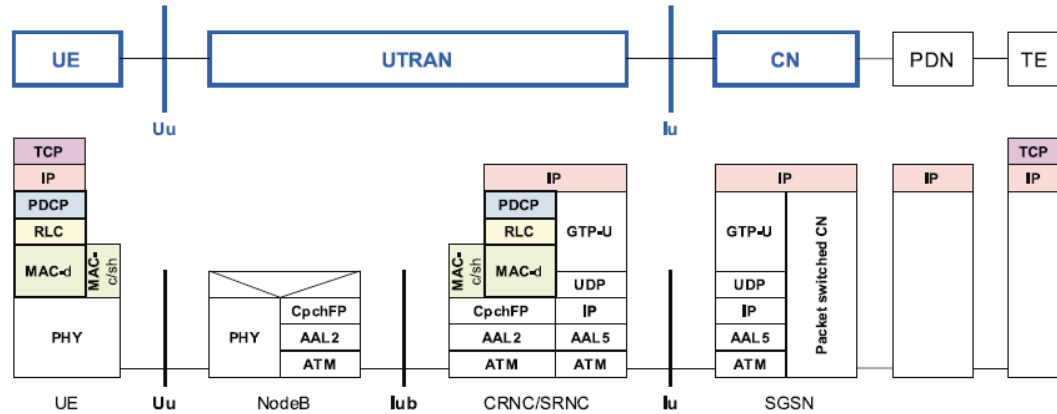

Figure 2-3: UMTS protocol stack (PS domain)

2.2 IP network and real-time applications

As a voice communication tool, VoIP is a real-time application which is very delay-sensitive. Let us have a look at the IP networks for real-time applications.

2.2.1 IP networks for real-time applications

IP networks are “best-effort networks”, which look like they are not suitable for Real-Time applications (Ghiasi and Po-Kuan, 2006). But IP networks have had some success in supporting real-time applications as benefit of the widely roll out of broadband Internet access (Upkar Varshney, 2002). Real-Time IP applications such as voice, video, and interactive gaming are becoming the wave of growth for IP networks. These bandwidth-intensive applications are referred to be as Real-Time applications because, unlike best-effort applications, they must be transported through a network with minimal delay or latency (Al-Mouhamed et al., 2005).

IP networks are highly dynamic. Any outage or change in the network will cause routing path re-calculating for the entire network (Yufei et al., 2001). This characteristic comes from the original design of the IP networks, which are designed for best-effort applications. It reduces the need for high reliability in the individual network elements (routers) or links, because after finding any outage or change, the network can simply re-converge and find an alternative route. This dynamic and self-re-converge network model is perfectly suited to best effort applications, such as e-

mail, web browsing and non-critical data transmitting, which are not time-sensitive and tolerant to some packet loss.

In contrast, real-time applications, such as voice/video calls, are very delay-sensitive and must be supported by a highly stable network (Jae-Chang, 1994). To support real-time applications, some improvements are required for the IP networks: reliability, stability and faster convergence (Fineberg, 2002). With the reliability of the network elements (routers and links) and the stability of the network, fewer interruptions would occur, and when interruptions occur, the faster convergence can reduce the impact. By addressing these three basic requirements, the IP networks can achieve the reliability and stability required to support new Real-Time services.

2.2.2 IP networks to support voice

In order for consumers to accept VoIP, the quality of VoIP calls should be equal to the traditional PSTN voice services. But since VoIP shares the same network with data transmitting either in the Internet or Intranet, it must compete with other applications for the limited network bandwidth. That brings up some requirements that VoIP needs to run over IP networks. VoIP, as a real-time, delay-sensitive application has special performance needs for bandwidth, delay, jitter and packet loss.

Bandwidth: A VoIP call needs a certain transmitting speed to continue the conversation. That means VoIP utilizes a certain bandwidth on the network when a continuous call is in progress. For example, a VoIP call using the high quality G.711 codec will utilize approximately 90 Kbps, while a standard video call can utilize 440 Kbps.

Delay: That is the time for the voice to travel from the speaker to the listener. The acceptable delay for a listener would fall into the range between 100 and 200 milliseconds.

Jitter: It is the variation in latency over time, and it must be small enough to provide with acceptable voice quality.

Packet loss: Packet loss begins to effect voice quality when its percentage reaches certain value.

Most of the non-real-time applications can perform well without meeting these requirements. By using a buffer or re-transmitting the data, the up-layer protocols can convert all these shortcomings into a delay, which is not critical for a non-real-time application. People generally do not expect real-time response for normal data applications. However, for voice, the situation is dramatically different. The high voice quality provided by the PSTN service has led to high end user expectations for all the voice communications. VoIP with poor performance is unacceptable and virtually unusable. As previously mentioned, VoIP has some performance needs to make it workable. There are also some more issues in transmitting voice over IP networks. The followings are some detailed discussion about their requirements and issues.

2.2.2.1 Bandwidth requirement

Telco quality voice requires sampling at 8 KHz. The bandwidth then depends on the level of quantization. With Linear quantization at 8 bits/sample or at 16 bits/sample, the bandwidth is either 64 Kbps or 128 Kbps.

In order to get VoIP calls at a Telco quality, two different approaches can be attempted. One is to transmit voice in the highest quality, which needs unrestricted bandwidth. Another approach is to transmit voice at a certain quality, which is competitive with PSTN call quality. By using the second approach, the required bandwidth can be reduced to a reasonable low level. Some source data are highly redundant, for example, a digital signal contains many strings of zeroes (or ones), and it will be economical to transmit a code indicating that a string of zero (or one) follows along with the length of the string. Compression and decompression (CODEC) of digital signals is a means of reducing the required bandwidth or transmission bit rate. Many different algorithms for compression and decompression of digital codes have been constructed. Pulse code modulation (PCM) and adaptive differential PCM (ADPCM) are examples of "waveform" CODEC techniques. Waveform CODECs are compression techniques that exploit the redundant characteristics of the waveform itself. In addition to waveform CODECs, there are source CODECs that compress

speech by sending only simplified parametric information about voice transmission; these CODECs require less bandwidth. Source CODECs include linear predictive coding (LPC), code-excited linear prediction (CELP) and multipulse-multilevel quantization (MP-MLQ). Coding techniques for telephony and voice packet are standardized by the ITU-T in its G-series recommendations. Some algorithms for voice compression and decompression are given in the Table 2-1.

Input Range	Transmission Rate	Standard
Linear Predictive Coding Algorithm	64 Kbps	LPC-10, G.711
Code Excited Linear Prediction (CELP)	8 Kbps	G.729, G.729A
32 Kbps Adaptive Differential Pulse Code Modulation (ADPCM)	32 Kbps	G.721

Table 2-1: Algorithms for voice compression and decompression

In order to transmit the voice information over IP networks, besides the actual bandwidth the voice data used, some extra bandwidth is required to cover adding the heads for each packet transmitted. These headers are IP, UDP and RTP. An IPv4 header is 20 octets; a UDP header is 8 octets and an RTP header is 12 octets. The total length of this header information is 40 octets (bytes), or 320 bits. These headers are sent each time a packet, containing voice samples, is transmitted. The additional bandwidth occupied by this header information is determined by the number of packets, which are sent each second. For example, if one packet carries the voice samples representing 20 milliseconds, the 50 such samples are required to be transmitted in every second. Each sample carries an IP/UDP/RTP header overhead of 320 bits (Perkins and Crowcroft, 2000). Therefore, in each second, 16,000 header bits are sent, which means an extra of 16 Kbps bandwidth is required. Islam (Islam et al., 2005) provides a detailed description of how to calculate the bandwidth requirements for VoIP over IP network transmission. Table 2-2 shows the IP bandwidth requirements for the most common coding algorithms.

Coding algorithm		Bandwidth	Sample	IP bandwidth
G.711	PCM	64kbps	0.125ms	80kbps
G.723.1	ACELP	5.6kbps	30ms	16.27kbps
	MP-MLQ	6.4kbps		17.07kbps
G.726	ADPCM	32kbps	0.125ms	48kbps
G.728	LD-CELP	16kbps	0.625ms	32kbps
G.729(A)	CS-ACELP	8kbps	10ms	24kbps

Table 2-2: IP bandwidth requirements for the most common coding algorithms

2.2.2.2 Delay

Delay is a vital element for VoIP, because Voice traffic is real-time traffic and if there is too long of a delay in voice packet delivery, speech will be unrecognizable and unacceptable. An acceptable delay is less than 200 milliseconds. Delays are caused by a number of different factors. There are basically two kinds of delay in VoIP networks: Propagation delay and Handling delay.

Propagation delay is caused by the characteristics of the speed of light/electrical signal travelling via a fiber-optic or copper medium of the physical layer of the network. Much cannot be done about the propagation delay, but sometimes it is a big part of the whole delay. It takes light about 100 ms to travel around the Earth, so a call to someone on the other side of the Earth would cause propagation delay of about 50 ms, which is a quart of the maximum acceptable delay.

Handling delay is caused by the devices that handle voice information and have a significant impact on voice quality in a packet network.

One big part of the handling delay comes from the network. This delay is an accumulation of queuing delay in network routers and switches.

Handling delay also includes the time a system takes to generate a voice packet, it may take 5ms to 20ms to generate a frame depending on the system, and usually one or more frames are placed in one voice packet.

Another contribution to this delay is the time taken to move the packet to the output buffer and the time the packet waiting in the output buffer before being processed.

Also, CODECs induce delay as well. There are various coding schemes available. Table 2-3 shows the best and worst case coding delays for the common CODECs. G711 is not listed in the table, because it does not compress the PCM sample and therefore, it does not experience a codec delay.

Codec	Rate	Minimum Sample block	Worst Case Codec Delay
ADPCM, G.726	32 Kbps	10 ms	10 ms
CS-ACELP, G.729A	8.0 Kbps	10 ms	10 ms
MP-MLQ, G.723.1	6.3 Kbps	30 ms	20 ms
MP-ACELP, G.723.1	5.3 Kbps	30 ms	20 ms

Table 2-3: Codec delay

2.2.2.3 Jitter

Jitter is defined as a variation in delay of VoIP packets reaching the receiver. The VoIP receiver expects packet flows to arrive at equal intervals of time, so it can play out a continuous voice stream. Any variation in that arrival of a packet creates jitter. Normally jitter can be compensated by using a jitter buffer for playing out the audio smoothly, but this way introduces some extra delay.

2.2.2.4 Reliability

Although IP networks are best-effort networks, the traditional data communication provides reliable end-to-end communication between two users by using mechanisms in up-layer protocols (TCP is a good example of this). It uses checksum and sequence numbering for error control and some form of negative acknowledgement with a packet retransmission handshake for error recovery. The negative acknowledgement with subsequent re-transmission handshake, introduces more than a round trip delay to transmission. For real-time applications, especially for VoIP, retransmitted packets might be entirely useless, so VoIP networks should leave the proper error control and error recovery scheme to higher communication layers. They can, thus, provide the level of reliability required, taking into account the impact of the delay characteristics. Although TCP/IP provides reliable connection, it is at the cost of packet delay or higher network latency. On the other hand, UDP is faster compared to TCP. Therefore, VoIP uses UDP as the transport level protocol. Reliability is built into higher layers. RTP over UDP/IP is usually used for voice and video communication.

2.2.2.5 Interoperability

In order to communicate using different products from different vendors, standards have to be confirmed. Currently the main standards are the H.323 and SIP. H.323 from ITU-T was the first set of agreed-upon standards, so it is quite popular. However, SIP from IETF is becoming more acceptable. It is relatively lightweight and easily scalable, so almost all the vendors are developing products on it.

2.2.2.6 Integration with PSTN

In the world that PSTN is still the most used telephony, VoIP needs to be integrated with PSTN to be more accepted and deployed. This will make PSTN and IP telephony networks appear as a single network to the end users and has been achieved through the use of gateways between the Internet on one hand and PSTN on the other.

2.3 An overview of VoIP

In modern society, it is considered to be essential for any business to have Internet access and Intranet. More and more communications are in digital forms and transported via packet networks such as IP, ATM, and Frame Relay. Since data traffic is growing dramatically, there comes a lot of interest in transporting voice over the data networks. Transporting voice communications using Internet Protocol (IP) is usually called “Voice over IP” or VoIP, and has become very attractive by giving the low cost.

2.3.1 An introduction of VoIP Systems

In the 1990s, a number of individuals in research environments, both in educational and corporate institutions, started researching the passing of voice over IP networks, especially corporate intranets and the Internet. This technology is commonly referred to today as VoIP. In simple terms, it digitizes the audio stream and breaks it into small chunks, then transmits those chunks over an IP network to the receiver. These chunks are collected and reassembled. This process converts a two people audio communication stream into a normal telephone call.

VoIP brings significant change in the way that people communicate. It gave users an option of using pure IP-based phones, including desktop computers, wireless phones and laptops, in addition to the telephones we have today. In Figure 2-4 (Net, 2008) shows how VoIP network can be connected and communicate with the normal PSTN network and Mobile network.

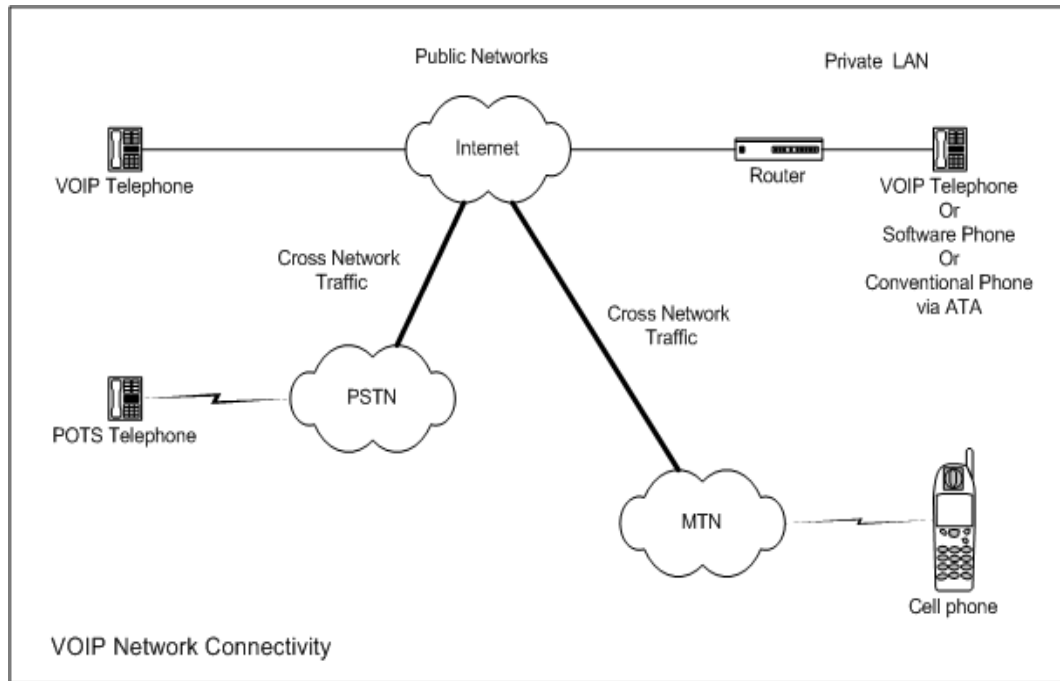

Figure 2-4: VoIP Network Connectivity

In the same concept, if we have sufficient bandwidth, we also have the ability to use videophone calls, much like those seen in science fiction movies. We can call home to see and talk to the family rather than just calling home to talk.

2.3.2 Importance and benefits of VoIP

First of all, VoIP offers significant cost savings relative to the PSTN. Remote branches and users can use VoIP to bypass the long-distance carriers, which charge them per minute. What they need to pay is a monthly Internet access fee.

Another aspect of VoIP is integration. VoIP gives us the ability to integrate a stand-alone telephone with the personal computer. People can use a computer for voice communications (softphones). VoIP also allows something else: the ability to use a single high-speed Internet connection for both voice and data communications. This idea is commonly referred to as convergence and is one of the primary drivers for corporate interest in the technology. The benefit of convergence should be fairly

obvious: by using a single data network for all communications, it is possible to reduce the overall maintenance and deployment costs.

In short, VoIP enables people to communicate in more ways and with more choices.

2.3.3 VoIP architectures

A whitepaper (Networks, 1998) suggested that to design and implement VoIP architectures, product developers are face challenges in 5 areas:

1. Voice quality should be comparable to what is available using the PSTN, even over networks having variable levels of QoS.
2. The underlying IP network must meet strict performance criteria including minimizing call refusals, network latency, packet loss, and disconnects. This is required even during congestion conditions or when multiple users must share network resources.
3. Call control (signalling) must make the telephone calling process transparent, so that the callers need not know what technology is actually implementing the service.
4. PSTN/VoIP service inter-networking (and equipment interoperability) involves gateways between the voice and data network environments.
5. System management, security, addressing (directories, dial plans) and accounting must be provided, preferably consolidated with the PSTN operation support systems.

Among many industry solutions, AT&T's Common VoIP Architecture and Cisco's AVVID are becoming outstanding. Cisco's AVVID (Architecture for Voice, Video and Integrated Data) is a well-known architecture and worthy to discuss. Cisco presents a typical IP telephony solution employing the Cisco AVVID network infrastructure (Cisco, 2003). The Cisco AVVID IP Telephony solution is the leading converged network telephony solution for organizations that want to increase productivity and reduce costs associated with managing and maintaining separate voice and data networks. The flexibility and sophisticated functionality of the Cisco AVVID Network Infrastructure provides the framework that permits rapid deployment

of emerging applications, such as desktop IP telephony, unified messaging, desktop collaboration, enterprise application integration with IP phone displays, and collaborative IP contact centres. These applications enhance productivity and increase enterprise revenues. Figure 2-5 (Cisco, 2003) illustrate a very typical VoIP solution.

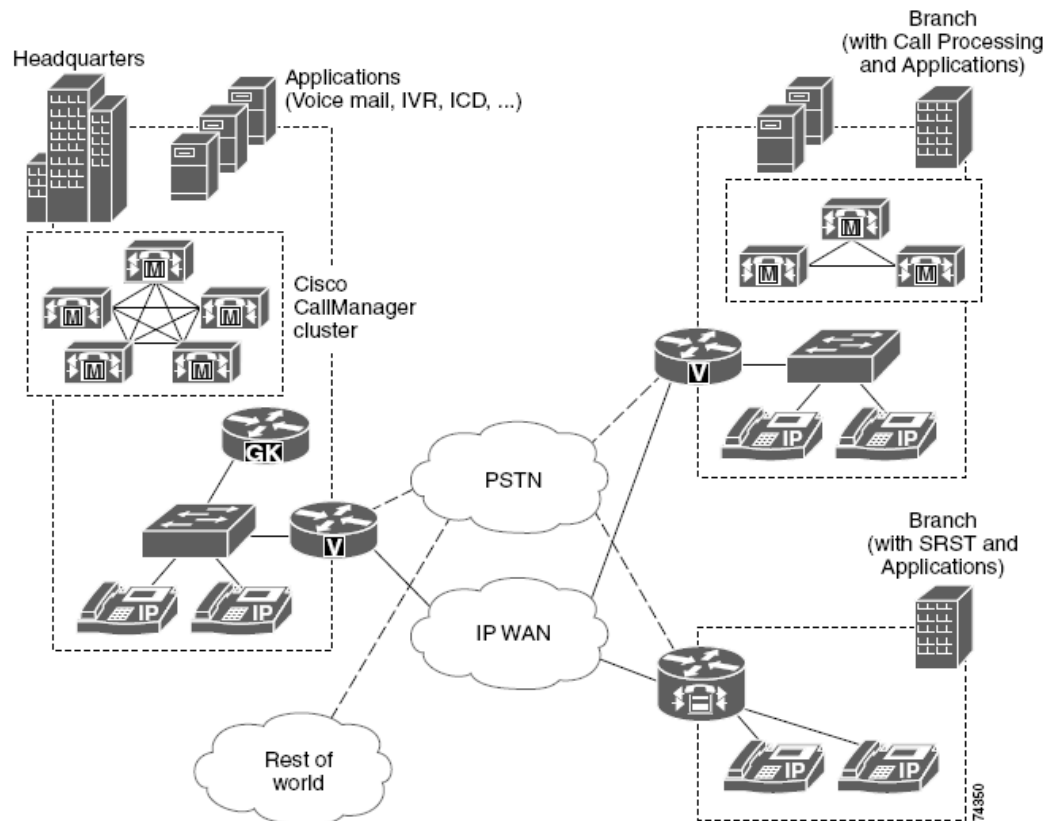

Figure 2-5: Typical IP Telephony Solution

2.3.3.1 Infrastructure for Cisco's AVVID

Cisco's AVVID is built on the multiprotocol routers and multilayer switches that are used to build up enterprise networks. Many Cisco products have the ability to terminate both analogue and digital voice interfaces for integration with PBX or PSTN.

As we discussed, to be able to transmit voice traffic over IP network, some requirements (such as QoS and bandwidth) need to be provided. The Cisco multilayer LAN switches offer the required features and functionality to achieve this goal. Advanced traffic classification, interface queuing and bandwidth provisioning techniques are required to ensure voice and videos are effectively transported. Some switches provide the required functionality including the ability to support line power by using Power over Ethernet (PoE).

2.3.3.2 Applications for Cisco's AVVID

There are lots of applications which can be enabled on a Cisco AVVID network, such as VoIP, unified messaging and the IP Contact Centres. Here, we focus on VoIP. A PBX can be eliminated and replaced with VoIP over a converged network. Cisco uses CallManager to enable VoIP on an AVVID network. The Cisco's CallManager provides call-control functionality. When CallManager is used in conjunction with the IP telephones or soft telephone applications, it can provide the PBX functionality in a distributed and scalable way. Cisco CallManager servers can be networked via IP and provide fall back to the PSTN, if required.

Cisco Systems is promoting the use and adoption of open standards and is participating actively in the definition and approvals process for a number of standards and open protocols in this arena. Cisco CallManager contains a number of interfaces that enable communications with external applications. That includes, Telephony Application Programming Interface (TAPI), Java Telephony Application Programming Interface (JTAPI), EXtensible Markup Language (XML) through HyperText Transfer Protocol (HTTP) messages, and H.323 endpoints. Enterprises can combine these interfaces within a single application, to develop their own applications with more features.

2.3.4 VoIP standards and protocols

The most popular and accepted VoIP standards are H.323 from ITU-T and SIP from IETF.

2.3.4.1 H.323 standard

H.323 is an ITU recommendation for multimedia communications over connectionless networks that do not guarantee Quality of Service (QoS), such as IP networks. The standard covers point-to-point communications and multipoint conferences. It addresses call control, multimedia management, bandwidth management, and interfaces between LANs and other networks.

Figure 2-6 illustrates the elements of H.323 architecture and their connection. The elements are User Terminals, GateWays (GWs), Multipoint Control Units (MCUs,) and GateKeeper (GKs).

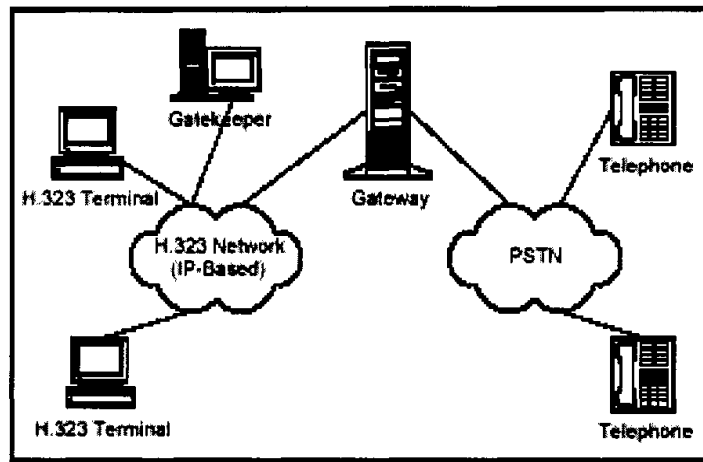

Figure 2-6: Basic H.323 Architecture

User terminals are normally IP phones or softphones. They provide real-time two-way communications. Gateways are used for integration with the PSTN network. They perform the translation of the signalling and media streaming exchanged between VoIP and PSTN networks. Multipoint control units are used for conferencing. All terminals participating in the conference establish a connection with the MCU. Gatekeepers are responsible for all authorization, address resolution and bandwidth management. Terminals, gateways and MCUs are generally called “Endpoints”.

There are many protocols involved in a H.323 system. Figure 2-7 (Protocols, 2008) shows the H.323 protocols in relation to the OSI model.

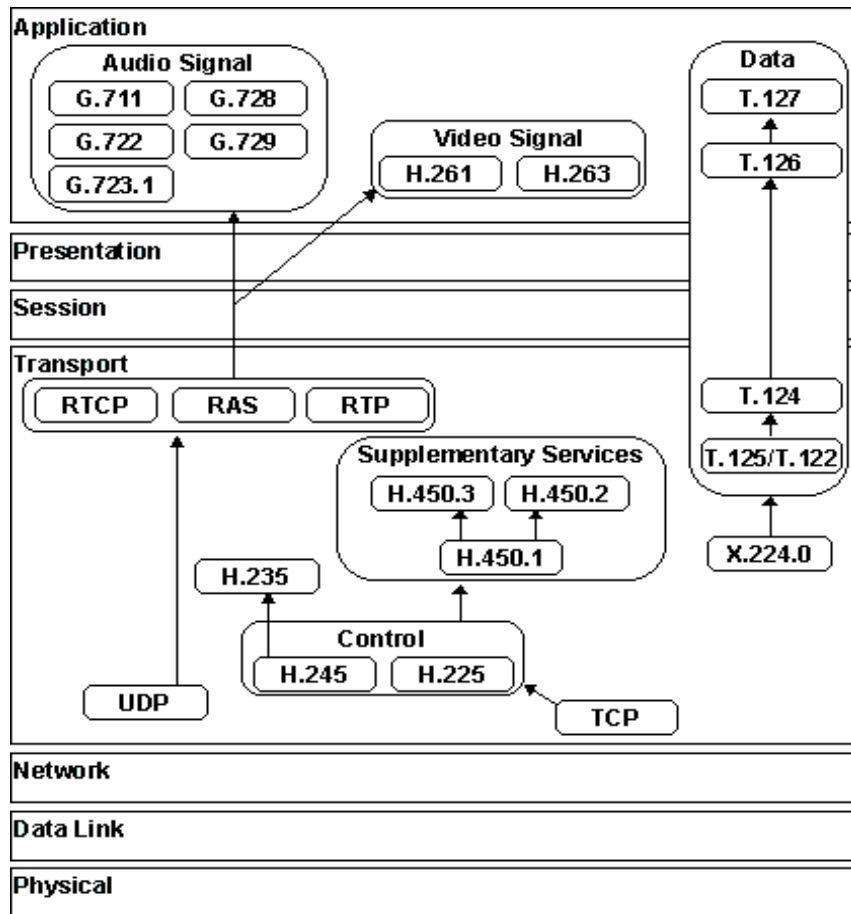

Figure 2-7: The H.323 suite in relation to the OSI model

The Registration Admission Status (RAS) protocol is the key protocol for GKs. When an endpoint joins the network, it sends the GK a RAS registration request (RRQ), which contains information about itself such as the endpoint address and user alias. If the GK accepts the registration, it sends a Registration Confirm message (RFC). Otherwise, it sends a Registration Reject message (RRJ). RAS messages are carried in UDP packets.

In an H.323 call setup life cycle, four key protocols are used: RAS, H.225, H.245 and RTP/RTCP. When an H.323 endpoint wants to make a call, it asks the GK for

permission by sending a RAS Admission Request (ARQ) message, which contains information of the destination endpoint. The GK may reject the request by sending back an Admission Reject (ARJ) message with a variety of reasons such as “not enough bandwidth” or “cannot find destination”. More commonly, the GK will grant permission for the call. The GK resolves the address (either locally, by consulting another GK, or by querying some other network service) and then sends back an Admission Confirm (ACF) message containing the actual destination address, alias, etc. Once the address of the remote endpoint is resolved, the endpoint will use H.225 Call Signalling, in order to establish communication with the remote endpoint. Many H.225 messages are used to establish the call, including Setup and Setup acknowledge, Call Proceeding, Connect, Alerting, Information, Release Complete, Facility, Progress, Status and Status Inquiry and Notify. Endpoints must notify their gatekeeper that they are in a call.

Once a call has concluded, a device will send a Release Complete message. Endpoints are then required to notify their gatekeeper that the call has ended. As soon as the call has initialised the two endpoints start using H.245 call control protocol. H.245 provides capabilities such as capability negotiation, master/slave determination, flow control, etc. The two endpoints agree on the nature of the information that will be exchanged through the media channel and its format (compression, encryption, etc.). After these procedures, the Real Time Protocol/Real Time Control Protocol (RTP/RTCP) starts to transfer the media data according to the endpoints’ capabilities. The actual media communication starts. Figure 2-8 (VoIPForo, 2006) shows the whole process of establishing and releasing an H.323 voice call. Some particular types of message are not discussed here.

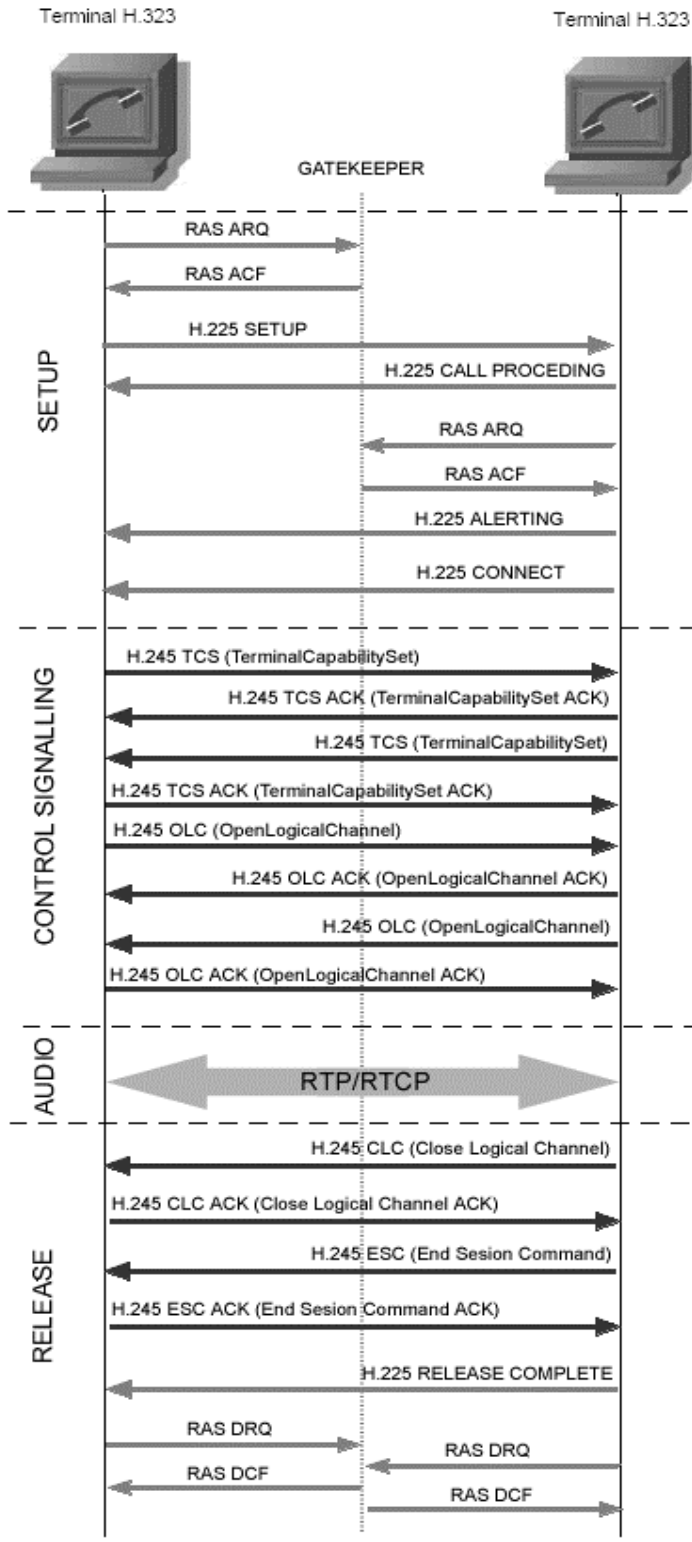

Figure 2-8: A typical H.323 call setup life cycle

2.3.4.2 Session Initiated Protocol (SIP) standard

The Session Initiation Protocol (SIP) is an Internet Engineering Task Force (IETF) standard protocol. SIP is a signalling protocol that can set up and tear down media communications such as voice/video calls over Internet. Although SIP was introduced later than H.323, it is playing a major role in VoIP.

Figure 2-9 (Cisco, 2007) shows the basic SIP architecture. The SIP architecture identifies two basic components: SIP users, normally called SIP User Agents (UA), and SIP Servers.

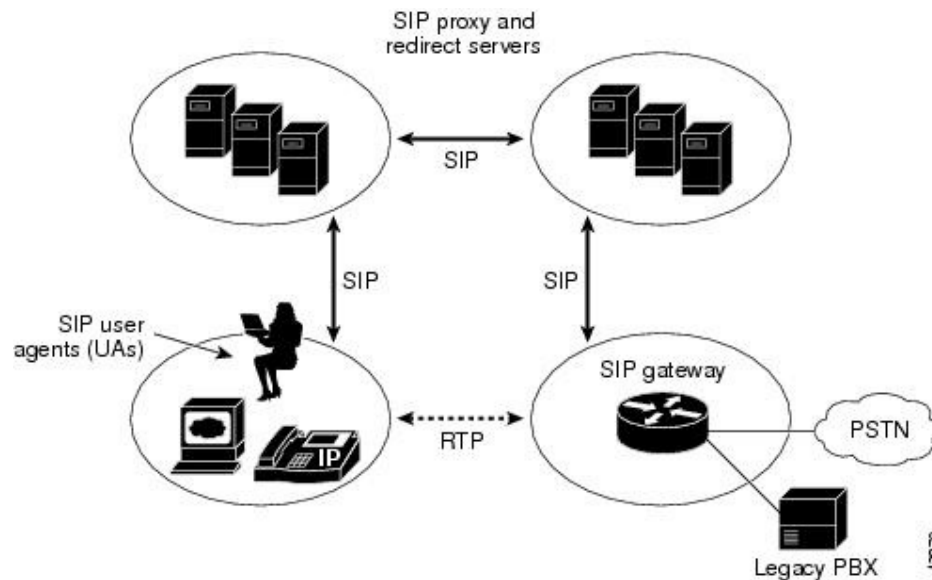

Figure 2-9: Basic SIP Architecture

A user agent can be a SIP enabled IP phone or just a softphone. It can function in one of the following roles:

User-agent client (UAC): A client application that initiates the SIP call request.

User-agent server (UAS): A server application that contacts the user when a SIP request is received and that returns a response on behalf of the user.

A SIP endpoint normally can function as both a UAC and a UAS, but it only can function as one in a conversation. The endpoint that initiated the SIP call request becomes the UAC and the remote endpoint becomes the UAS.

In SIP architecture there are three different server groups:

SIP Registrar Server: A server receives and processes registration message from UACs regarding their current user location. Registrar servers are often co-located with a redirect or proxy server.

SIP Proxy Server: A server forwards the SIP messages to multiple proxy servers, in order for the SIP messages to reach their destinations. Proxy servers can provide functions such as authentication, network access control, routing, etc.

Redirect Server: A server helps endpoints to find the desired address by redirecting them to another server.

SIP uses Session Description Protocol (SDP) to describe the sessions that will be set up. A SIP INVITE message includes a SDP message as a payload, describing the capabilities of calling agent and then both parties negotiate on the capabilities of the session will be set up. Figure 2-10 (Fox and Uyar, 2001) indicates the protocols involved in a SIP voice call and their relationship.

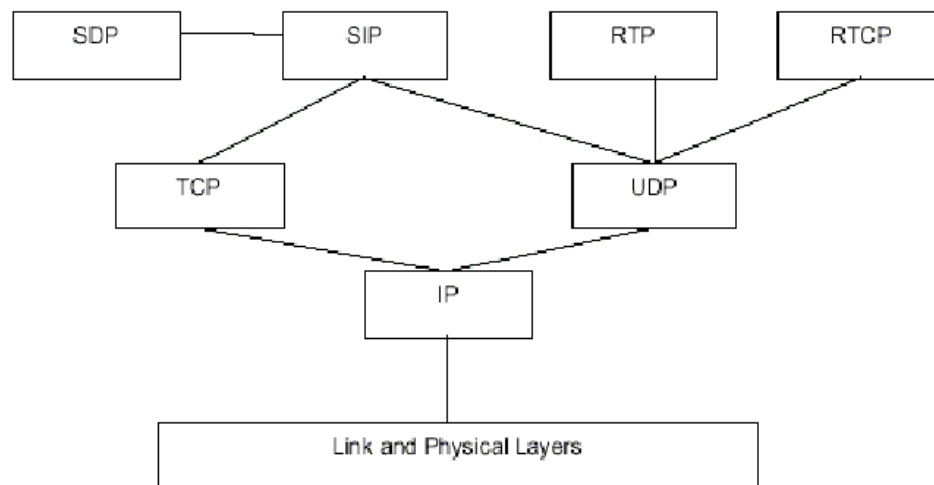

Figure 2-10: SIP protocol stack

The procedures of establishing a SIP call under different circumstances are slightly different. In some scenarios, UA needs to contact with Servers to be able to find out and connect with remote endpoint. Figure 2-11 (Proulx, 2007) shows a typical SIP call process without involve of any servers.

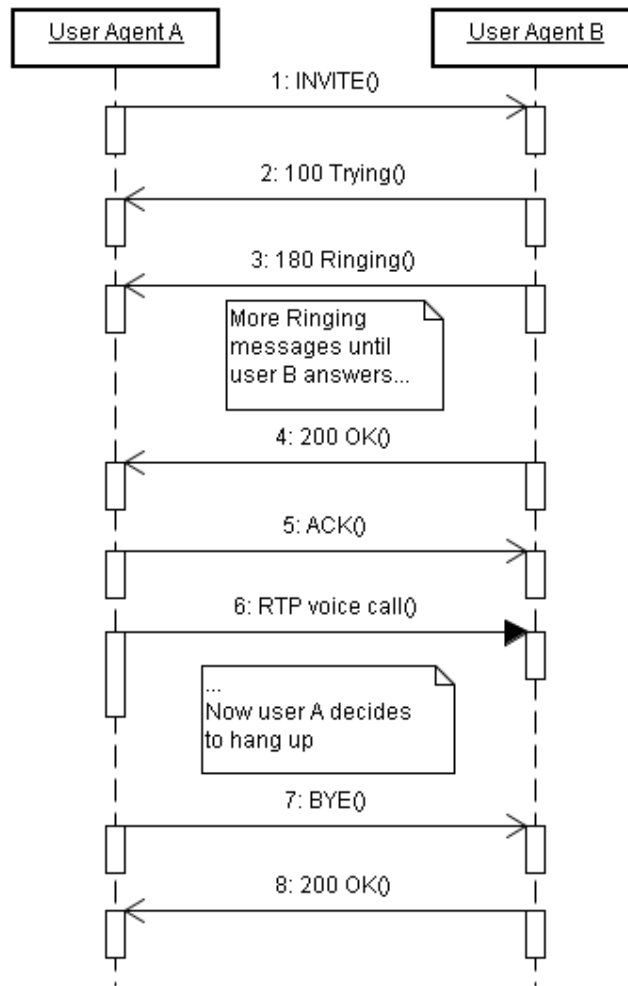

Figure 2-11: A typical SIP call

User Agent A (UA A) sends a SIP request "INVITE" to User Agent B (UA B) to indicate its wish to talk to UA B. This request contains the details of the voice streaming protocol. The Session Description Protocol (SDP) is used in the payload for this purpose. The SDP message contains a list of all media CODECs supported by UA A. After UA B received the request, it confirms the receiving with UA A. While the

phone rings, UA B sends provisional messages (ringing) to UA A. When UA B accepts the call, it sends an OK response to UA A. In the payload of the response, there's another SDP message. It contains a set of media CODECs that are supported by both user agents. At this point both parties are officially in the call. All types of SIP requests are accepted using 200-type responses. UA A finally confirms with an ACK message. Both user agents are now connected using the method selected in the last SDP message. At the end of the communication session, one of the users hangs up. At this point this UA A sends a new request, BYE. The other user's user agent accepts the request and replies with an OK message. The call is disconnected.

2.3.4.3 RTP and RTCP

In both SIP and H.323 standards, Real-time Transport Protocol (RTP) and Real-time Transport Control Protocol (RTCP) are used to transport the voice over the Internet. RTP/RTCP were designed for providing end-to-end network transport functions suitable for applications transmitting real-time data, such as audio, video or simulation data, over multicast or unicast network services (Schulzrinne, 2003). RTP is the one to carry the real-time data, while RTCP is to monitor the transmission QoS and generate the statistic information for the participants in the session.

As called Real-time transport protocol, RTP itself even does not provide guaranteed timely delivery. Also, it does not have any mechanism to ensure the QoS, such as in-order delivery and packet re-delivery. Despite this, RTP, along with RTCP, is one of the foundational VoIP protocols.

RTP is build on top of the User Datagram Protocol (UDP), which is running in transport layer and also only provides unreliable best-effort data transmission. Every RTP packet has a fix-long header which contains the packet information. Figure 2-12 shows the structure of a RTP packet. As we can see in the figure, the header includes (Schulzrinne, 2003):

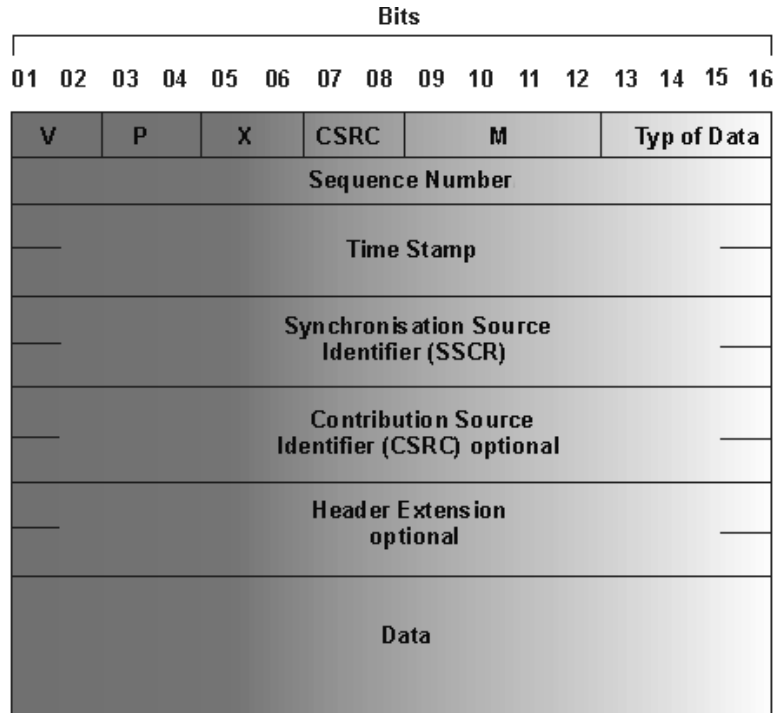

Figure 2-12: RTP packet structure

- Version (V): 2 bits, identifies the version of RTP.
- Padding (P): 1 bit, used to identify if there are any extra padding octets at the end RTP packets.
- Extension (X): 1 bit, identifies if a header extension is used after the fixed header.
- CSRC count (CC): 4 bits, contains the number of CSRC identifiers that follow the fixed header.
- Marker (M): 1 bit, defined by a profile. It is intended to allow significant events such as frame boundaries to be marked in the packet stream
- Payload type (PT): 7 bits, indicates the format of the payload and determines its interpretation by the application.

-
- Sequence number: 16 bits, increments by one for each RTP data packet sent, and may be used by the receiver to detect packet loss and to restore packet sequence. The initial value of the sequence number is random.
 - Timestamp: 32 bits, reflects the sampling instant of the first octet in the RTP data packet.
 - SSRC: 32 bits, indicates the synchronization source.
 - CSRC list: 0 to 15 items, 32 bits each. The CSRC list identifies the contributing sources for the payload contained in this packet. The number of identifiers is given by the CC field.
 - Extension header: Indicates the length of the extension in 32bit units, excluding the 32bits of the extension header.

RTP uses a fixed packet header, while RTCP has several different packet types. These different packets carry variety of control information (El-Marakby and Hutchison, 1998):

SR: Sender report, for transmission and reception statistics from participants that are active senders

RR: Receiver report, for reception statistics from participants that are not active senders and in combination with SR for active senders reporting on more than 31 sources

SDES: Source description items

BYE: Indicates end of participation

APP: Application-specific functions

RTCP is based on periodic transmission of control packets to all the participants of a particular session (Li, 2001). All participants in the session send RTCP packets. The control packets are distributed in the same way as the data packets. Each RTCP packet includes, a sender and/or receiver reports, that report statistics, such as number of

packets sent, number of packets lost, inter arrival Jitter, delay since last sender report, time of last sender report, etc., useful to the application (Li, 2001).

2.4 Quality of Service (QoS) in VoIP

In PSTN network, quality of service for every phone call is guaranteed by the constant available bandwidth. While packet networks work the opposite way, when bandwidth availability drops, data can still be transmitted through but in a slows transmission speed. It would be critical to the real-time applications. The idea of QoS is to meet the requirements of the real-time applications by applying some mechanism to control and provide better service to them (Wenyu et al., 2003). It is commonly applied in the situations where VoIP is available. The parameters used for QoS of VoIP are end-to-end delay, jitter and packet loss. To deal with QoS, a way to measure the quality of voice calls has to be established first.

2.4.1 Mean Opinion Score (MOS)

A common benchmark used to determine the quality of speech is the Mean Opinion Score (MOS). To get a MOS of a speech, a group of listeners rate the quality of sample speech on a scale of 1 to 5, with 5 being the best quality. The averaged score is taken as the MOS of that speech (Zurek et al., 2002).

Each CODEC provides a certain quality of speech. Table 2-4 (Bakshi, 2006) lists the MOS for the common used CODECs.

CODEC	G.711	G.723.1	G.726	G.728	G.729
MOS	4.5	3.6	4.2	4.2	4.2

Table 2-4: MOS for common CODECs

2.4.2 Delay

As we discussed in 2.2.2.2, the total end-to-end delay is the sum of a packet assembly at the source, a network delay and receiver delay.

ITU G.114 (ITU-T, 2003a) recommends:

- 0-150 ms, acceptable for most applications
- 150-400 ms, acceptable but has impact
- Above 400 ms, unacceptable

While a more common and used limit for delay in VoIP is that the acceptable delay should be less than 200 milliseconds.

Delay in transporting a voice packet over the IP network causes two main problems: Echo and Talker Overlap. When the round trip delay through the network becomes greater than 50 ms, echo becomes a problem. Echo cancellers are used to avoid the problem. Since the IP networks normally have higher end-to-end delay, echo cancellation becomes an essential requirement for VoIP. In addition, with the increasing of delay, the Talker Overlap becomes more serious and it can be extremely annoying. When the delay gets more than 250 ms, the connection sounds like half-duplex and cannot be claimed as an interactive session.

2.4.3 Jitter

Jitter is the variance of packet arrival time. It is defined to be the mean deviation of the packet spacing change between the sender and the receiver (Li, 2001). It is measured in milliseconds.

In an IP network, it is not guaranteed that the packets arrive at the receiver with the same and equal intervals as they are sent at the sender. That is where jitter comes from. In order to get high quality voice calls, in VoIP applications, Jitter buffers are used. The incoming packets are held for a specified amount of time to allow the slowest packets to arrive before they are used to produce the voice stream. Jitter buffers introduce additional delay.

To decrease the additional delay introduced by the Jitter buffer, the size of the Jitter buffer should be decreased also. However, a too small Jitter buffer increases the packet loss which can cause bad voice quality. There are two ways to optimize the Jitter

buffer size. In a network, that provides a consistent Jitter performance over time, it is better to measure the variation of packet arrival in the Jitter buffer over a period of time and adapt the buffer size to match the calculated Jitter. On the contrast, for the network with high variable packet arrival intervals, it is better to count the number of packets that arrive late and calculate the ratio of these packets to the number of packet that are successfully processed. Then use this ratio to adjust the jitter buffer size.

2.4.4 Packet loss

Packet loss is a very important parameter of QoS. Generally speaking, a packet loss rate of 5% will annoy users. Packet loss usually occurs when there is congestion on the packets path, which causes the router buffers to overflow. The stability of the network heavily influences the packet loss rate (Li, 2001).

A lot of research have been done in relation to the packet loss and VoIP quality. Different CODECs can be affected by packet loss differently. G.711's highest MOS score is about 4.4, while G.729A has only got highest MOS of 3.6 (Wallingford, 2005). When packet loss occurs, G.711 can be less affected than G.729A, especially when the packet loss rate is more than 5%. Figure 2-13 (Wallingford, 2005) shows the different effect of packet loss for G.711 and G.729A. Also, different type of packet loss will introduce different results for VoIP quality (Dansereau et al., 2006). In (Clark, 2003), the effects of random and burst packet loss have been investigated. Figure 2-14 shows the different effects between the random and burst packet loss.

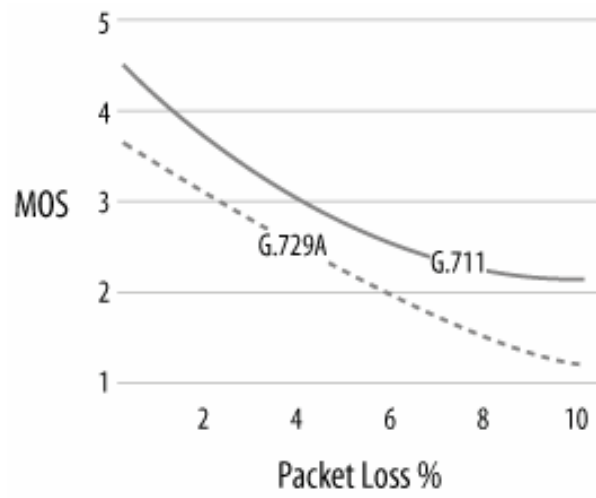

Figure 2-13: MOS rating with packet loss

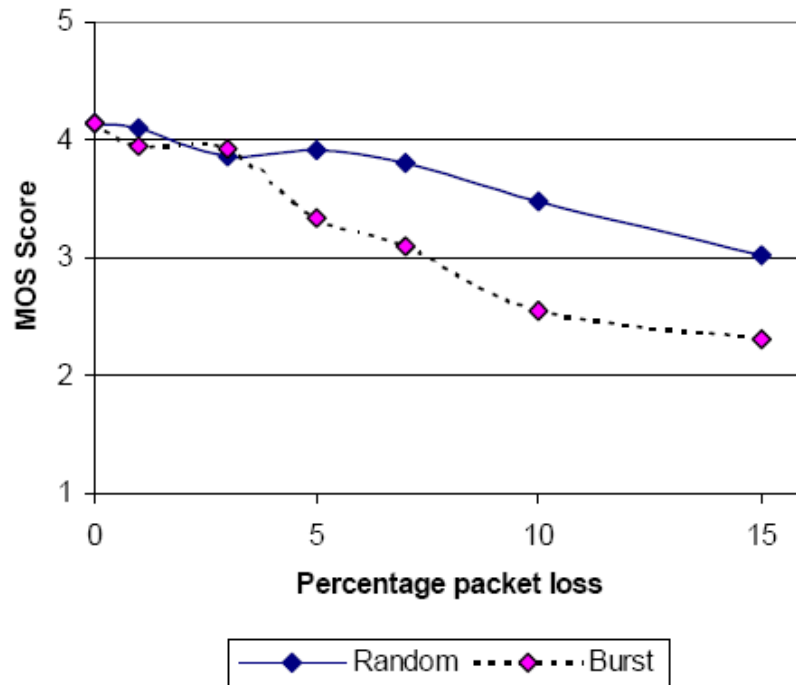

Figure 2-14: Effects of Random and Burst Packet Loss

2.5 E-Model

E-Model (ITU-T, 2006) is a technique that provides a prediction of the expected voice call quality. The E-Model takes a wide range of telephony impairments into account, such as, the impairment due to low bit-rate coding and one-way delay, and the telephony impairments associated with noise and echo.

2.5.1 E-Model algorithm

The primary output of the E-Model calculations is a quality rating value known as R (Transmission Rating Factor). The E-Model is based on a mathematical algorithm, with which the individual transmission parameters are transformed into different individual "impairment factors" that are assumed to be additive on a psychological scale. The algorithm of the E-Model also takes into account the combination effects for those impairments in the connection which occur simultaneously, as well as some masking effects. R is given by the equation (ITU-T, 2006):

$$R = R_o - I_s - I_d - I_e + A$$

Where:

- R_o represents the basic signal-to-noise ratio (SNR);
- I_s represents the combination of all impairments which occur more or less simultaneously with the voice signal;
- I_d represents the impairments caused by delay;
- I_e represents impairments caused by low bit rate CODECs;
- A is the advantage factor, that corresponds to the user allowance due to the convenience in using a given technology.

The range of the value for R is 0 to 100, with higher values indicating higher speech quality. Table 2-5, taken from (ITU-T, 1999), shows how the E-Model Ratings R relative to categories of speech transmission quality and to user satisfaction.

Range of E-Model Rating R	Speech transmission quality category	User satisfaction
$90 \leq R < 100$	Best	Very satisfied
$80 \leq R < 90$	High	Satisfied
$70 \leq R < 80$	Medium	Some users dissatisfied
$60 \leq R < 70$	Low	Many users dissatisfied
$50 \leq R < 60$	Poor	Nearly all users dissatisfied

Table 2-5: Definition of categories of speech transmission quality

2.5.2 E-Model and MOS

The E-Model R factor can be converted to MOS rating which is in ranges from 1 to 5. In (Carvalho, 2005), the relation between R factor and MOS rating has been presented as follows:

- For $R < 6.5$: $MOS = 1$
- For $6.5 \leq R \leq 100$: $MOS = 1 + 0.035R + 7.10 - 6R(R - 60)(100 - R)$
- For $R > 100$: $MOS = 4.5$

2.5.3 E-Model parameters

A lot of parameters are involved to calculate the R factor by using the formula:

$$R = R_o - I_s - I_d - I_e + A$$

These parameters are used to calculate R_o , I_s , I_d and I_e . It involves some complicated mathematic calculations and will be discussed in detail in the next chapters. Table 2-6, taken from (ITU-T, 2004), lists all the parameters, their abbreviations and unit.

Parameter	Abbr.	Unit
Send Loudness Rating	SLRS	dB
Receive Loudness Rating	RLRR	dB
Sidetone Masking Rating	STMR	dB
Listener Sidetone Rating	LSTR	dB
D-value of telephone, send side	Ds	–
D-value of telephone receive side	Dr	–
Talker Echo Loudness Rating	TELR	dB
Weighted Echo Path Loss	WEPL	dB
Mean one-way delay of the echo path	T	ms
Round trip delay in a 4-wire loop	Tr	ms
Absolute delay in echo free connections	Ta	ms
Number of Quantization distortion units	qdu	–
Equipment impairment factor	Ie	–
Packet-loss Robustness Factor	Bpl	–
Random Packet-loss Probability	Ppl	%
Circuit noise referred to 0 dBr-point	Nc	dBm0p
Noise floor at the receive Side	Nfor	dBmp
Room noise at the send side	Ps	dB(A)
Room noise at the receive side	Pr	dB(A)
Advantage factor	A	–

Table 2-6: E-Model parameters

2.6 Chapter summary

In this chapter, firstly, the conception of VoIP and its characters have been introduced, followed by the discussion of the requirements for IP networks to support the real-time applications including VoIP. After, the detailed architecture of VoIP is discussed with the most common protocols and standards. As the extension of the requirements of VoIP, QoS comes up and some QoS related parameters have been mentioned. To predict and measure QoS, the E-model has been introduced. Finally, this chapter also presents a brief overview of UMTS over which the QoS of VoIP will be investigated and discussed as the major part of this research work.

As a relatively new technology, UMTS network has some different characters from traditional IP networks. E-model can be used to predict and measure the quality of VoIP over UMTS network, if the proper parameters are chosen and the default value of the parameters can be determined, according to the specific network.

3 Objectives

The research objective is to implement a VoIP E-Model technique over a hybrid UMTS network and then to compare the research results with results presented in the literature for other network types and configurations. The research included development of a model and simulation environment that could be used to gain results suitable for analysis.

Initially, the research effort included a background review of VoIP, UMTS and the E-Model technique.

Research on VoIP services included: (1) IP networks, (2) real-time applications, (3) TCP/IP protocols, (4) RTP/RTCP protocols, (5) SIP, (6) H.323 and (7) voice over IP CODECs.

The E-model technique may be used to predict and measure voice service quality and performance (Carvalho et al., 2005). In this thesis, the E-Model technique will be discussed and associated parameters will be investigated.

The UMTS network technology is relatively new and there is scope for research regarding the implementation of VoIP over a UMTS network, interconnected with the broader digital network, forming a hybrid network for real-time services. In this thesis, UMTS is considered as a VoIP implementation network for high density voice services.

Research was first carried out to gain an understanding of UMTS networks and the suitability of UMTS networks for real-time services and associated network management and control protocols that would facilitate better management of time critical real-time services. The E-Model technique incorporates parameters that may be predicted or measured. Some of the parameter default values can be determined by analysing the network being used for VoIP services or part of that network, which may be the UMTS network. By doing this, the E-Model calculation formula can be simplified and tailored for use with a UMTS network.

After the E-Model formula has been simplified and tailored for the hybrid UMTS network used in the research, the research effort moves on to a VoIP over UMTS simulation created using Opnet Modeler (OPNET, 2009). In Opnet Modeler, a hybrid UMTS network will be simulated and VoIP traffic transferred over the network. By changing the background network traffic characteristics, VoIP phone calls with different qualities can be generated and the network statistics collected. Finally, the VoIP call data collected can be used as input information applied to the simplified E-Model formula. The resulting VoIP Service QoS will then be calculated and the R factor found for each VoIP traffic type.

3.1 Assumptions

The research presents an approach to simplify the E-Model technique calculation formula and apply it to VoIP services over a hybrid UMTS network. The experimental data, used in the analysis, was collected from a simulation. A necessary number of assumptions were made to ensure reasonable results can be generated within the research time-frame. The major research assumptions made were:

- The network models and protocols provided and used within the Opnet Modeler simulation application were considered to be reasonable and suitable for the research. References to other research using Opnet Modeler and the network models have been provided.
- The E-Model calculation formula uses parameters that depend on the physical environment. In the Opnet Modeler simulation environment, these parameters are set to default values. To use the E-Model calculation formula, default values have to be determined by assuming the phone calls are taking place in a generic environment.
- The different type of terminals used in a VoIP call will introduce different voice quality, as will the CODECs used to digitise and compress the audio, which reflects different E-Model parameter values. In this thesis, it is assumed that typical computer base VoIP terminals are used.

3.2 Research limitations

In this research, there are some limitations which would impact the research results. Some were self-imposed limitations, while some others are due to external factors. These limitations include:

- The E-model was not designed and developed for the modern IP networks (Carvalho et al., 2005). Some characteristics of the modern IP networks were not taken into account when the E-Model was developed. In order to get better results, the E-Model parameters should be re-calculated to reflect current IP network characteristics.
- The E-model is additive. It simply adds the impairment factors for multiple systems, to calculate the R factor, while VoIP networks are known to be non-additive and non-linear (Waltermann and Raake, 2008).
- As Opnet Modeler is used to simulate the hybrid UMTS network the data collected and analysed would be slightly different from results collected using a real system. Opnet Modeler is one of the leading simulation software applications available today and for this reason the limitations associated with its use are considered acceptable.

4 Experimental and Theoretic Work Completed

This chapter provides a detailed review of the research work carried out and identifies the results that are to be analysed in the next chapter. The research work contains three important parts:

- E-model simplification
- VoIP over hybrid UMTS network Modeling
- Simulation and analysis

This chapter begins with development of the hybrid UMTS network and implementation of the VoIP service across the hybrid UMTS network model. After the model development and testing within Opnet Modeler, preliminary data is used with the E-Model to gain a greater understanding of how the E-Model may be used for VoIP over a hybrid UMTS network. Finally, the E-Model calculations will be simplified to suite this research environment. Different test scenarios will be discussed, and simulations will be done to generate statistical data from each of the scenarios. The data collected is used in E-Model calculations and the outcomes are analysed to identify an improved E-Model technique.

4.1 VoIP over hybrid UMTS modeling

This research project uses Opnet Modeler 14.0 to simulate the hybrid UMTS network and the VoIP calls running over it.

4.1.1 Opnet Modeler simulation environment

The Opnet Modeler simulation environment utilises two mechanisms to manage simulations called Project and Scenario. Projects are always the top level in any Opnet Modeler simulation. Every project contains one or more scenarios, which represent particular network configurations to be simulated. Generally, a scenario is a network configuration including the topology, protocols, applications, services and traffic flow.

A project may contain more than one scenario. Each scenario uses a network that is slightly different or the same with varied parameters. In this research, a hybrid UMTS network was created with two VoIP end-points. This scenario was duplicated with changes to the network and parameters for each simulation. For some of the scenarios, more IP traffic was added to show varying levels of congestion. The use of scenarios has permitted results to be obtained from a number of similar networks with minor variations to the network or parameters and the results have been used in the analysis and comparison described later.

To model the hybrid UMTS network, a new project and scenario was created using the Opnet Modeler “start-up wizard”. As shown in Figure 4-1, the project was named VoUMTS and the default scenario name was used. After the names have been entered, the start-up wizard starts.

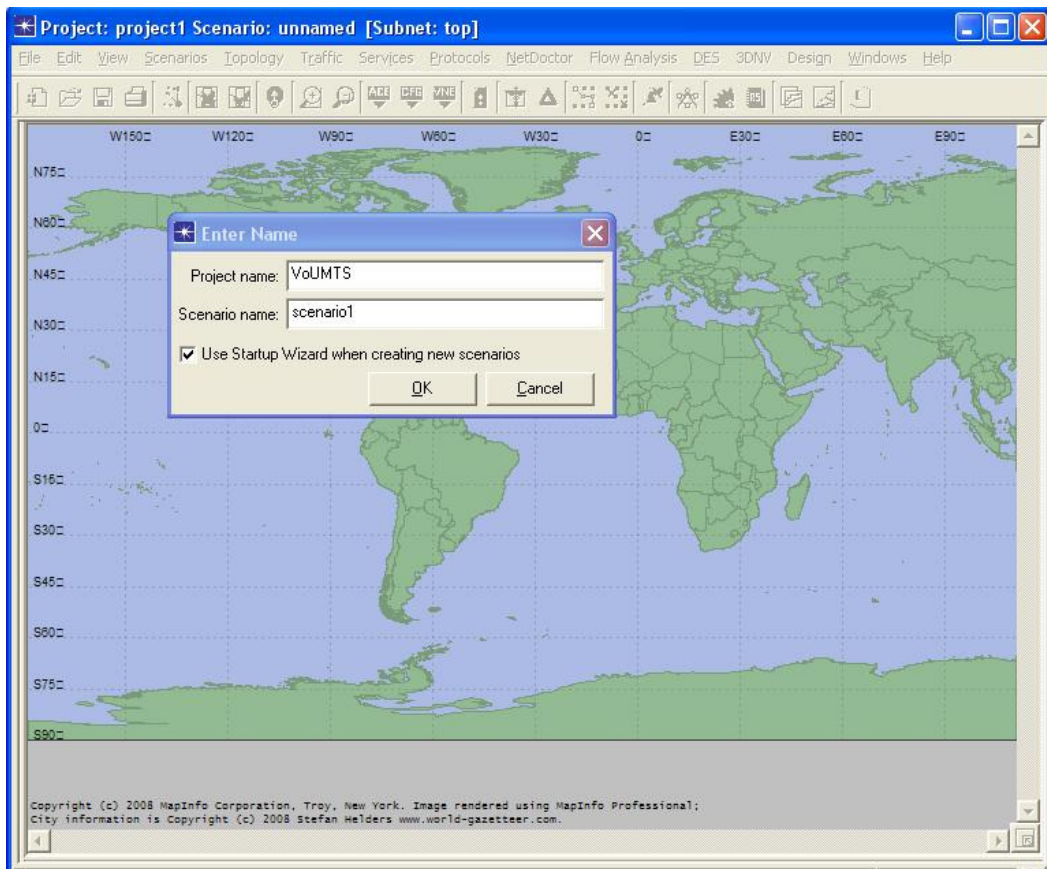

Figure 4-1: New Project - Project and Scenario names

The first step of the start-up wizard is to choose the initial network topology. The wizard gives some options to create the initial scenario as shown in Figure 4-2. The topology can either be imported from some specially formatted files or created from scratch manually. In this research, there is no pre-made network topology available that can be used, so the network topology was created from scratch manually. In Figure 4-2, “Create empty scenario” has been chosen.

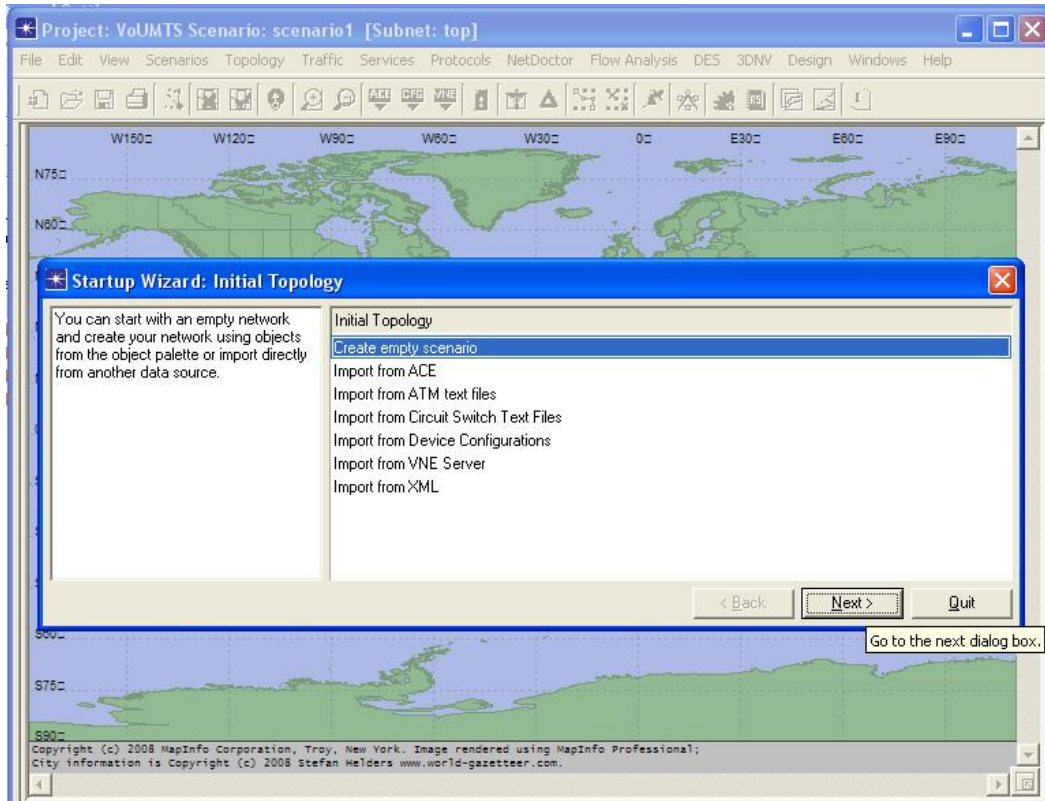

Figure 4-2: Start-up Wizard – Initial Topology

The next step is to choose the network scale and size. In this research project, a basic UMTS network has to be simulated. It includes all the UMTS elements such as base stations, RNCs, SGSNs and GGSNs. To include all this equipment, “Campus” has been selected as the network scale. The size of the campus network is specified as shown in Figure 4-3.

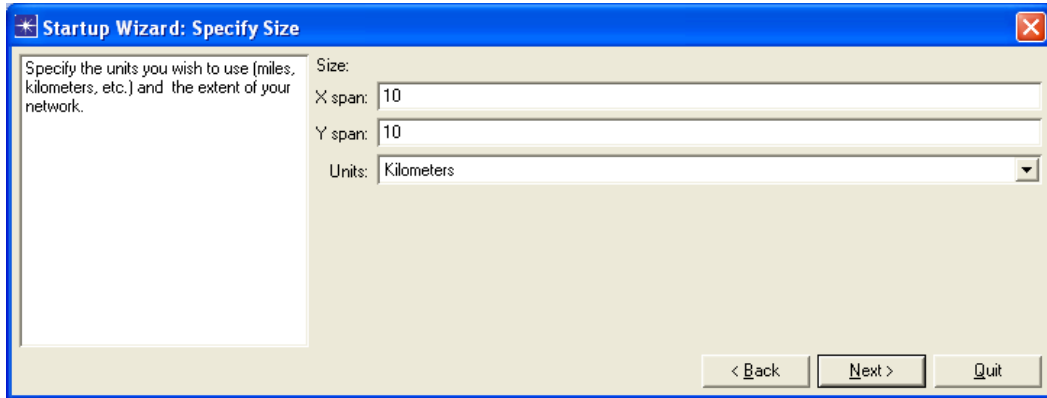

Figure 4-3: Startup Wizard - campus network size

After the network scale and size have been chosen, the next step is to select the technologies that will be used in the network. This selection will be used to create the Object Palette, which holds items that are used often in the project editor. All of the models that were included in the selected technologies will be put into the Object Palette, so they can be easily placed into the project. As this research project is to simulate VoIP over hybrid UMTS network, UMTS and UMTS_advanced technologies have been selected as shown in Figure 4-4.

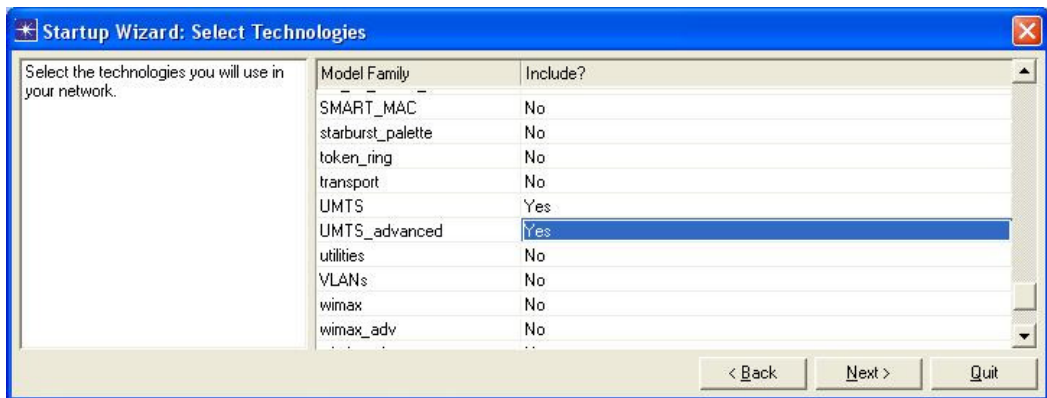

Figure 4-4: Start-up Wizard - Select Technology

Before the Start-up Wizard finishes, it gives a review of the scenario summary. Figure 4-5 shows the summary of the first scenario that is going to be created.

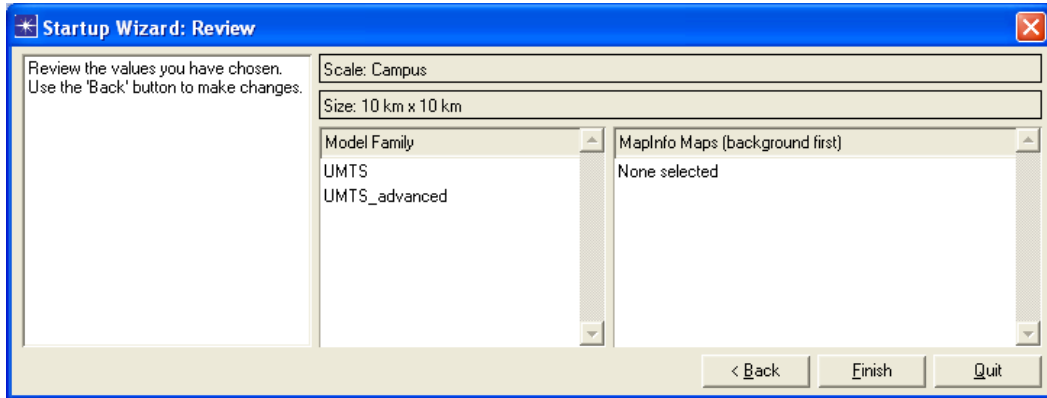

Figure 4-5: Start-up Wizard – Summarise

Finally, after finishing the Start-up Wizard, the Object Palette pops up with all the models that maybe needed to create the scenario network. Figure 4-6 shows the Object Palette created for one of the project scenarios. At this point, the network simulation environment has been setup and it is ready to be used for network Modeling and simulation.

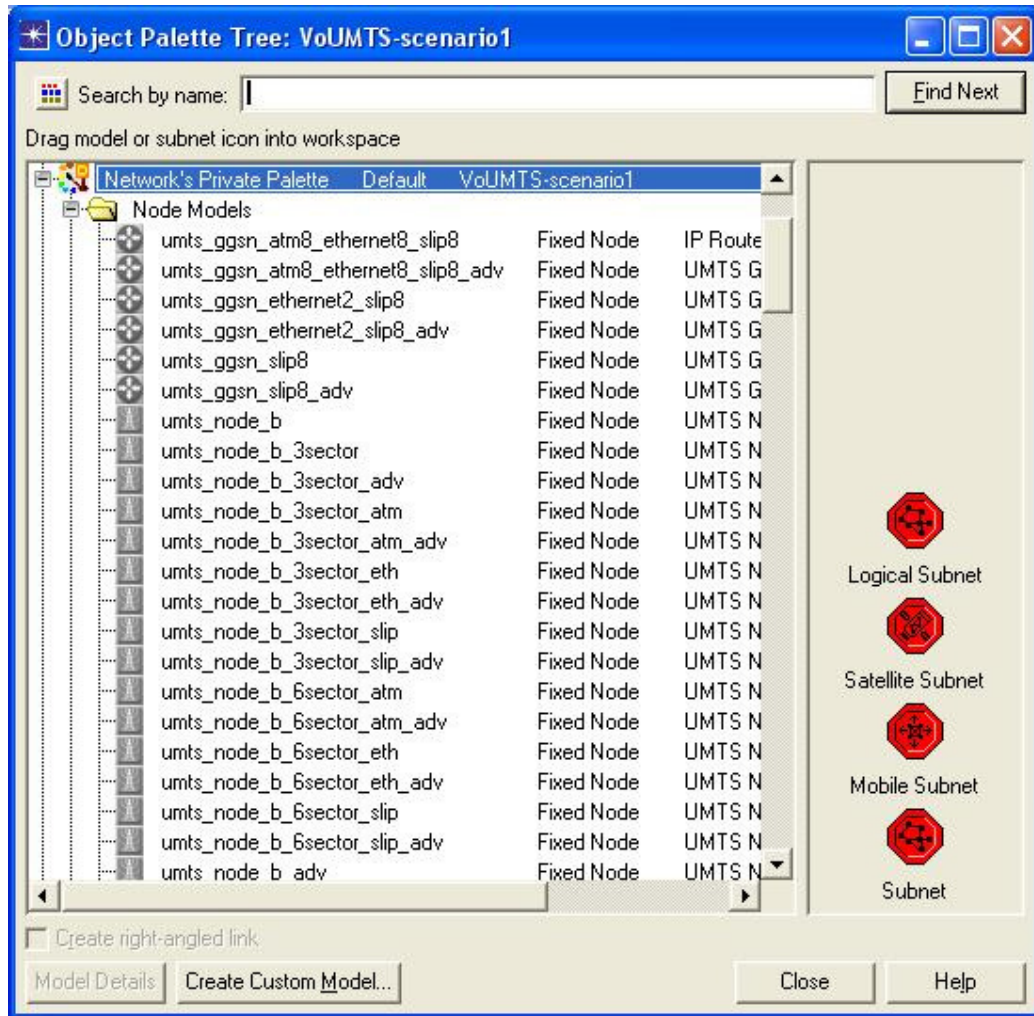

Figure 4-6: Start-up Wizard - Object Palette

4.1.2 Hybrid UMTS network Modeling

In this research, a simple hybrid UMTS network is modelled with only two end users connected to the UMTS network. These two end users are connected into the UMTS network via different base stations. They also have access to the internet, so they can access servers outside the UMTS network, such as SIP server, Web server, FTP server and E-mail server. Figure 4-7 shows the sketch topology that this research used. Simply, the two end users can make VoIP calls to each other by using the SIP server in the Internet section of the network. They can, also simultaneously, access the Internet for other services such as Web, FTP and E-mail.

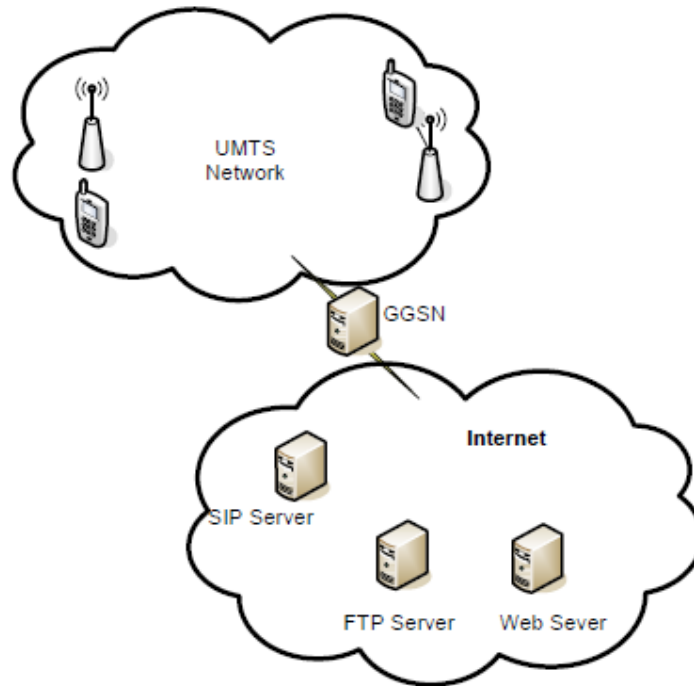

Figure 4-7: VoIP over hybrid UMTS sketch topology

As discussed in Chapter 2, a UMTS network consists of three domains: Core Network (CN), UMTS Terrestrial Radio Access Network (UTRAN) and User Equipment (UE). To model a UMTS network, all the UMTS essential models should be added into the scenario and connected properly.

UMTS networks contain both circuit switched and packet switched networks. In this research project, only a packet switched network is concerned, so there is no need to model the circuit switched elements like Mobile services Switching Centre (MSC), Visitor location register (VLR) and Gateway MSC. The two key packet switched elements are Serving GPRS Support Node (SGSN) and Gateway GPRS Support Node (GGSN). They are essential for the UMTS core network and must be modelled in this project. To model the UMTS core network, we start with the IP backbone in the core network. In this project, 4 routers are used as the IP backbone. They are connected with PPP_DS3 links, as shown in Figure 4-8. All the SGSNs and GGSNs should be connected to these routers.

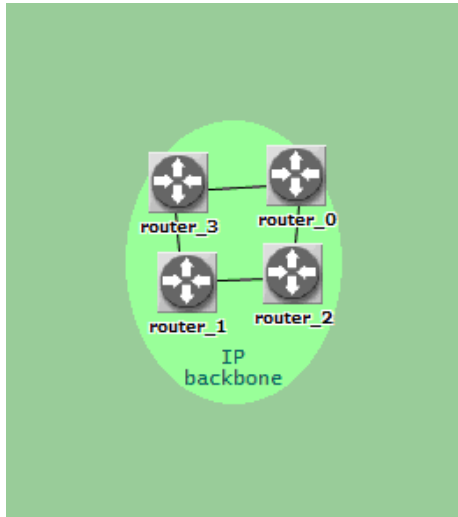

Figure 4-8: Hybrid UMTS Modeling - IP Backbone

After setup the IP backbone, the SGSN models can be put into the project. The numbers of the SGSN models depend on the scale of the network. In this case, only two are required and they are connected to the IP backbone using PPP_DS3 links. Figure 4-9 shows the core network after SGSNs are added.

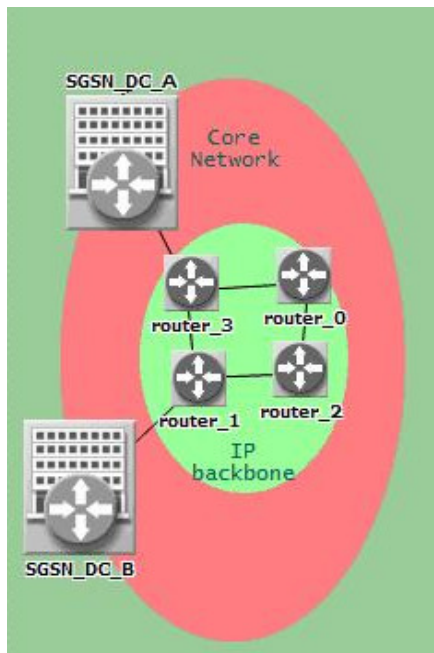

Figure 4-9: Hybrid UMTS Modeling - Core Network

The next step is to add the UMTS Terrestrial Radio Access Network (UTRAM) models into the network. It includes two different network models: the radio network controller (RNC) model and the Node B (also known as base station) model. One or more RNCs can be connected to a SGSN and one or more base stations can be connected to a RNC. ATM_OC3 links are used to connect the base stations to the RNCs and the RNCs to the SGSNs. In this research, a simple UMTS network with only two base stations is used. Figure 4-10 shows the topology and connections for this research.

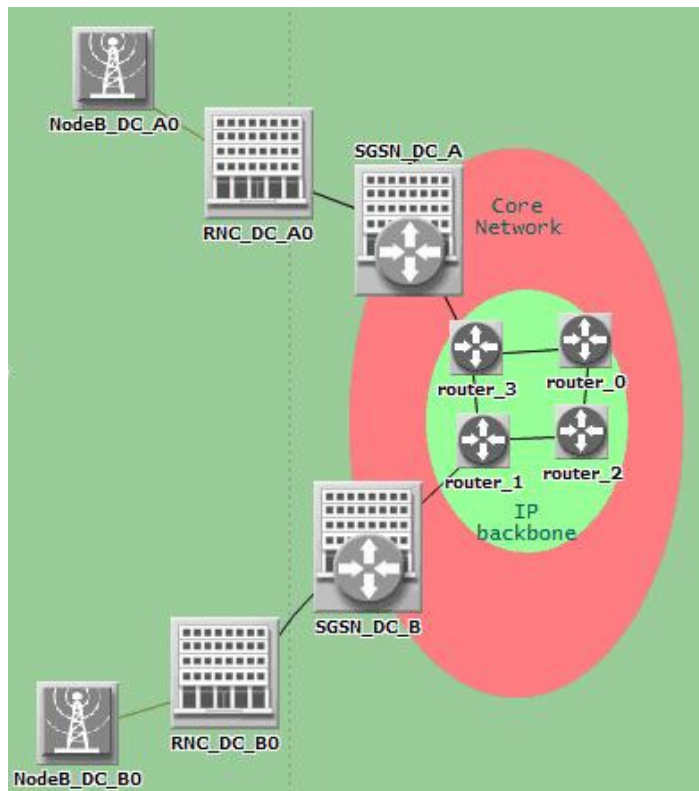

Figure 4-10: Hybrid UMTS Modeling - UTRAM added

Opnet Modeler includes a UMTS workstation model, which can be used as the UMTS user equipment (UE). The UMTS workstation model can simulate a normal IP workstation. They can be used as VoIP end users and other IP service clients. In this research, two UMTS workstation models have been added (as shown in Figure 4-11) to simulate VoIP calls and other IP activities.

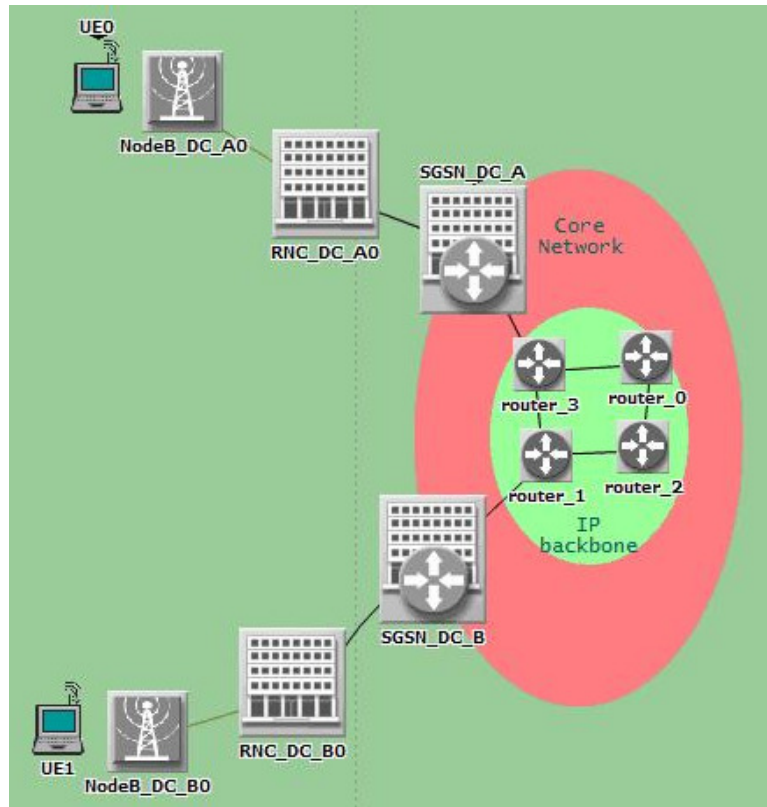

Figure 4-11: Hybrid UMTS Modeling - End users added

To make the UMTS workstation models connect to the UMTS network in Opnet, the workstations have to be manually configured to use the right SGSN. In this instance, open the attributes dialog SGSN_DC_A by right clicking and selecting “Edit Attributes (Advanced)”, under “UMTS parameters”. There is a parameter called “SGSN ID” (shown in Figure 4-12). All the UMTS workstations that use the base stations connected to this SGSN have to set the same ID as their SGSN serving ID. After opening the UE0’s attributes dialog, the “UE Serving SGSN ID” setting can be found under “UMTS” (shown in Figure 4-13). By default, the “UE Serving SGSN ID” is set to “0”. In this case, we change it to “1” to match the SGSN ID of SGSN_DC_A. The same setting, also, has been done to UE1.

Here, a base UMTS network has been modelled.

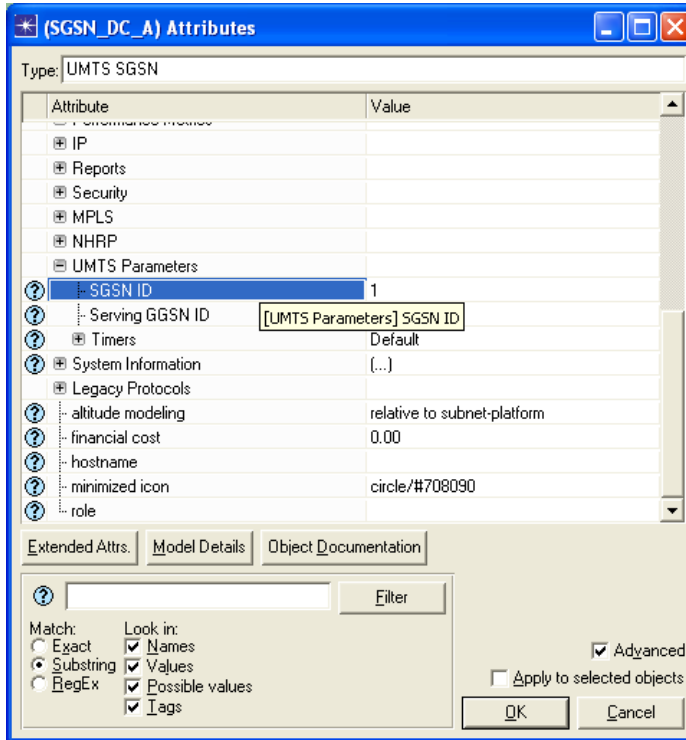

Figure 4-12: Hybrid UMTS Modeling - UMTS parameters configuration for SGSN

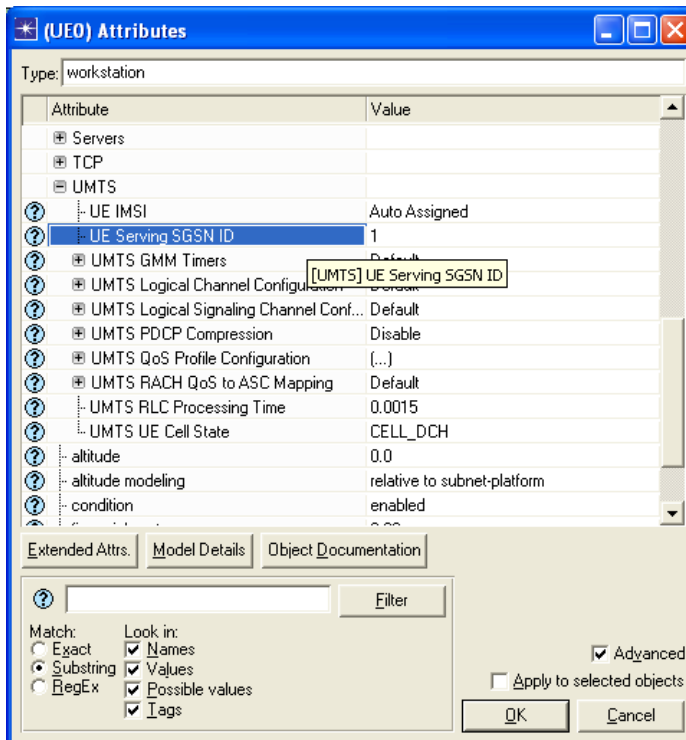

Figure 4-13: Hybrid UMTS Modeling - UMTS parameters configuration for UE

To add Internet access to the UMTS network, a GGSN model has to be added in the UMTS core network. Opnet also have an IP Internet model IP32_Cloud to represent the Internet. PPP_DS3 links are used to connect the GGSN to the UMTS IP backbone and the Internet (as shown in Figure 4-14).

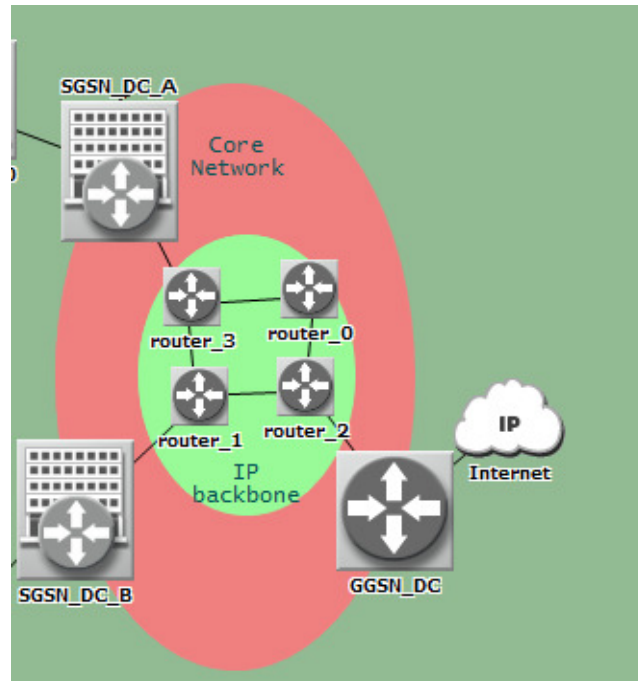

Figure 4-14: Hybrid UMTS Modeling - connecting to Internet

In this research scenario, the UMTS end users should be able to access some servers inside the Internet, so other network services can be provided to them. To simulate this, all the servers can be connected to another side of the Internet cloud via a router. Figure 4-15 shows, in other side of the Internet, a router model has been connected using a PPP_DS3 link. This router is used to connect the three servers into the internet. Each serve is connected to the router suing a 10baseT link, and can provide more than one service.

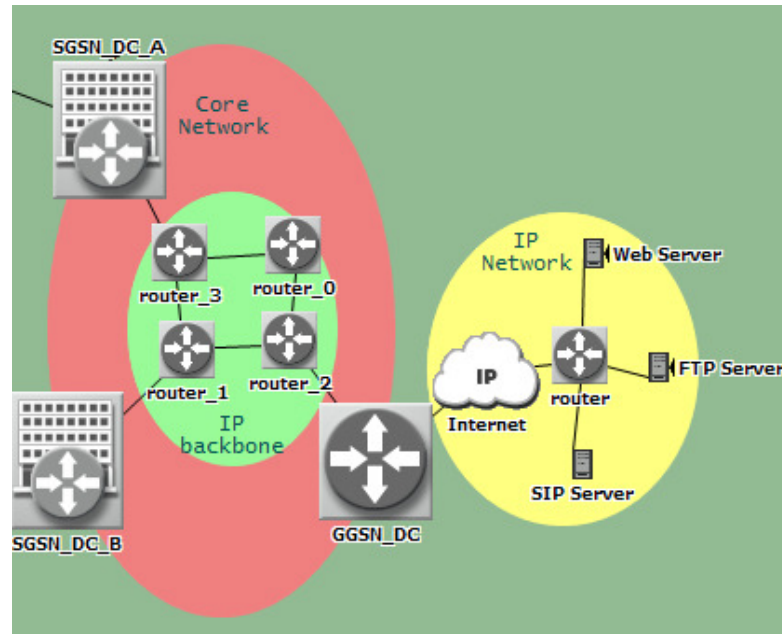

Figure 4-15: Hybrid UMTS Modeling - With IP network connected

After the simulation network topology has been setup, before the simulation can be run, the important step is to configure application definitions and profile definitions. All the applications that can be used in this simulation scenario are configured in application definitions. Profiles define groups of applications that might be used by a certain group of users and also define the activities of these applications used by the group. Opnet has the nodes call “application config” and “profile config”. They can be added into the scenario. Figure 4-16 shows the final simulation topology for this research project. The configuration of the configure application definitions and profile definitions will be discussed before running the simulation.

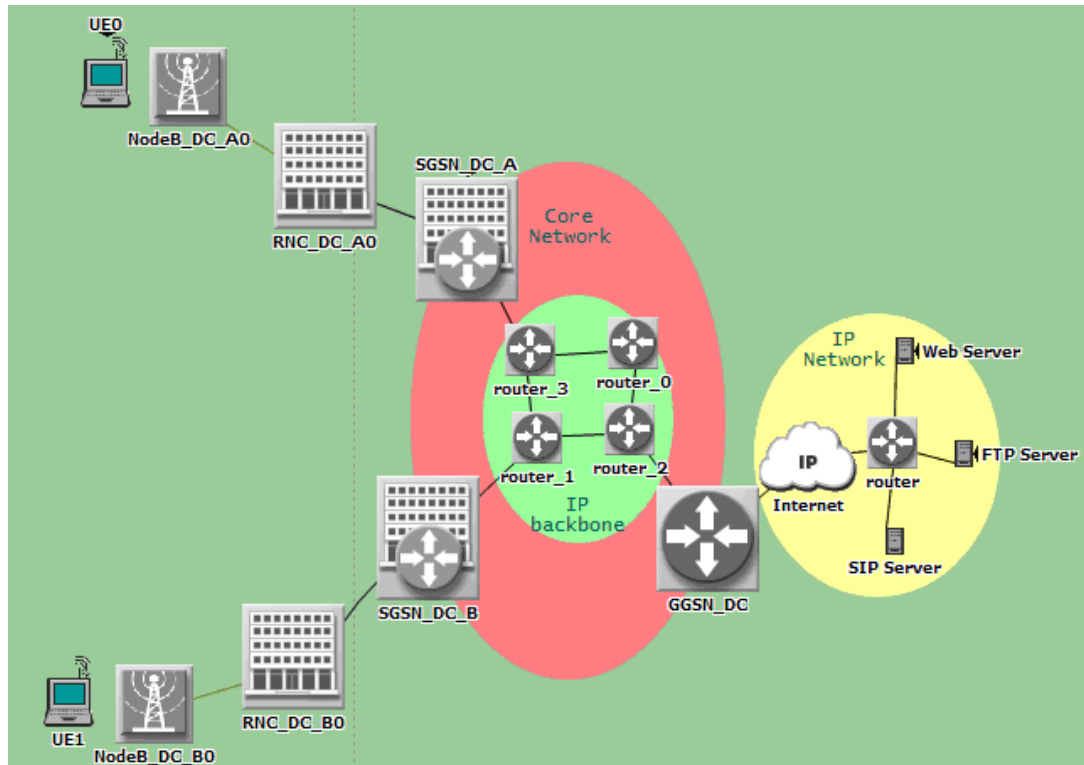

Figure 4-16: Hybrid UMTS Modeling – Final simulation topology

4.2 VoIP over Hybrid UMTS simulation

4.2.1 Configure the simulation

After the simulation network environment has been setup, the next step is to configure applications. Opnet has some most common applications predefined. What needs to be done is to add these applications into the Applications Definitions and configure their behaviour. In this research, VoIP and some other applications are to be added and configured. Before we start this, firstly we change the scenario name from “scenario 1” to “GSM quality” to represent that in this scenario, only GSM quality VoIP calls, which use GSM FR codec, will be made, no other applications will be running. After this scenario is configured, it can be duplicated and more applications can be added in.

In the Attributes Dialog of Applications Definitions, under the “Application Definitions” setting, the value of “Number of Row” represents the number of Applications defined (As shown in Figure 4-17).

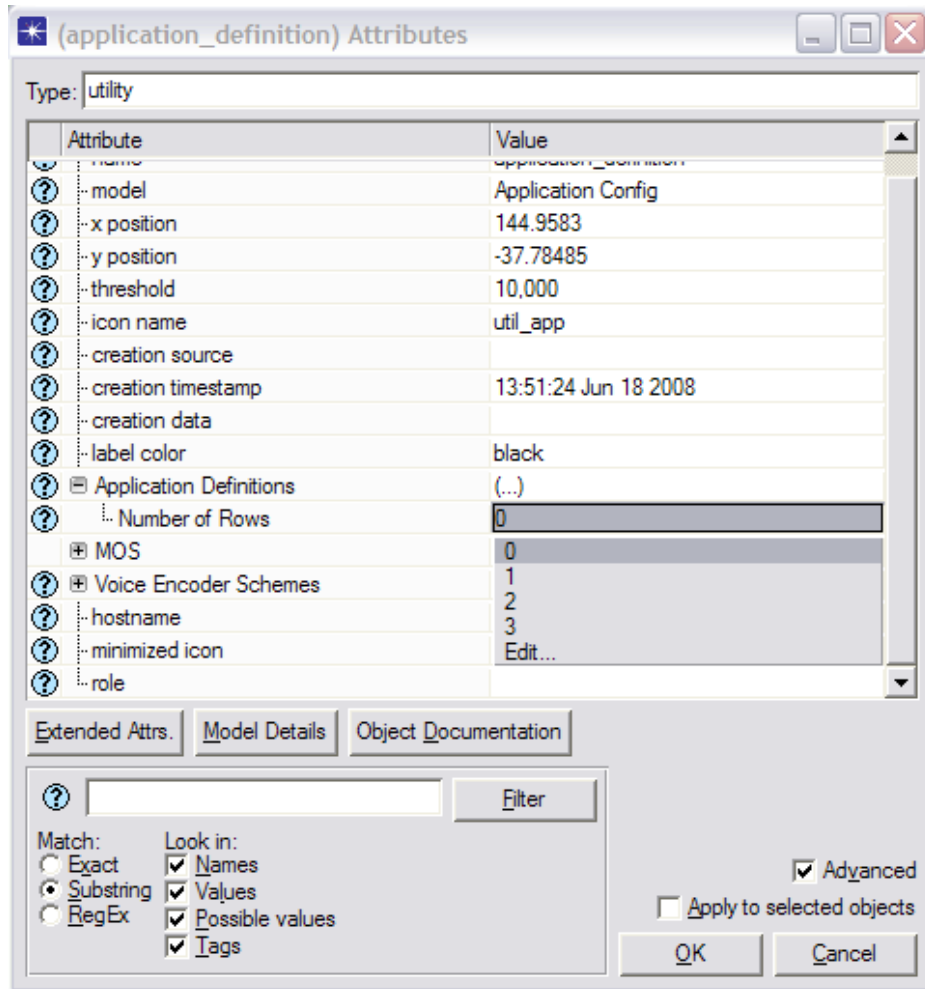

Figure 4-17: Application Definitions - Number of Applications

Start with one application. After a new Row of Applications Definition has been added, a name should be given to the application. In this case, “VoIP (GSM Quality)” has been given. If we open the “Description” setting, there are options including the basic predefined applications and a custom application which can be edited to simulate some special applications such as Email, HTTP, Ftp and Voice. Figure 4-18 shows all the options available for the application definitions.

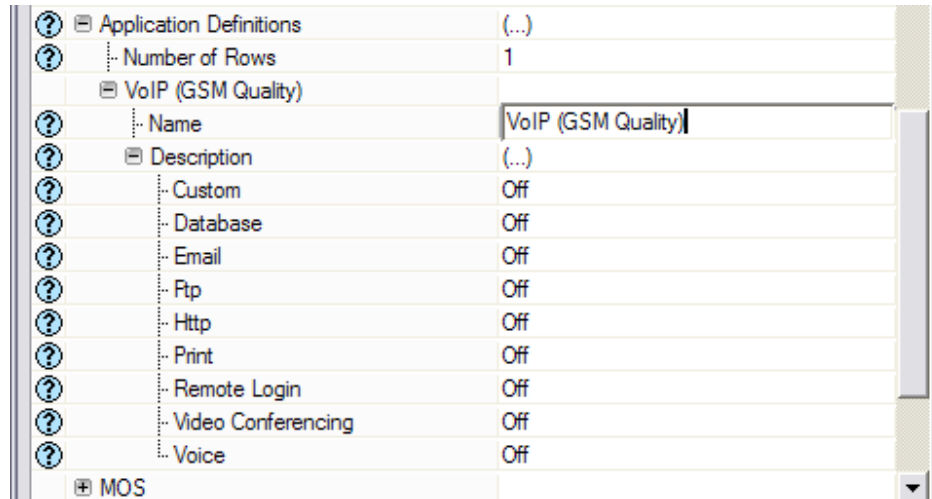

Figure 4-18: Application Definitions - Predefined Applications

In this case, the Voice application is going to be selected and configured. Opnet also have some predefined voice application settings. The options will drop down when the “value” cell of the Voice setting is clicked (shown as Figure 4-19). One of these can be selected, also the “Edit” option can be clicked to custom the application. In this scenario, “GSM Quality and Silence Suppressed” is selected.

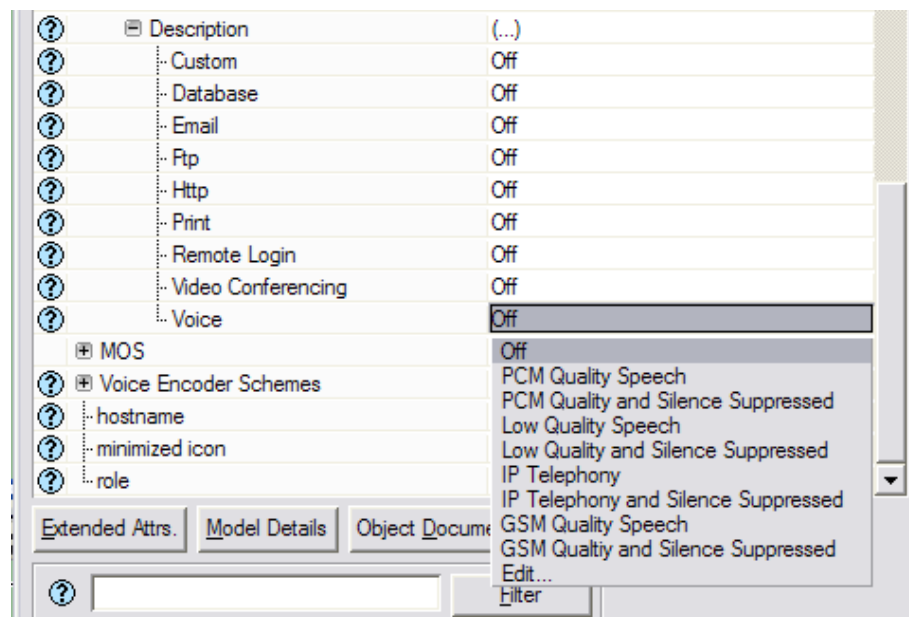
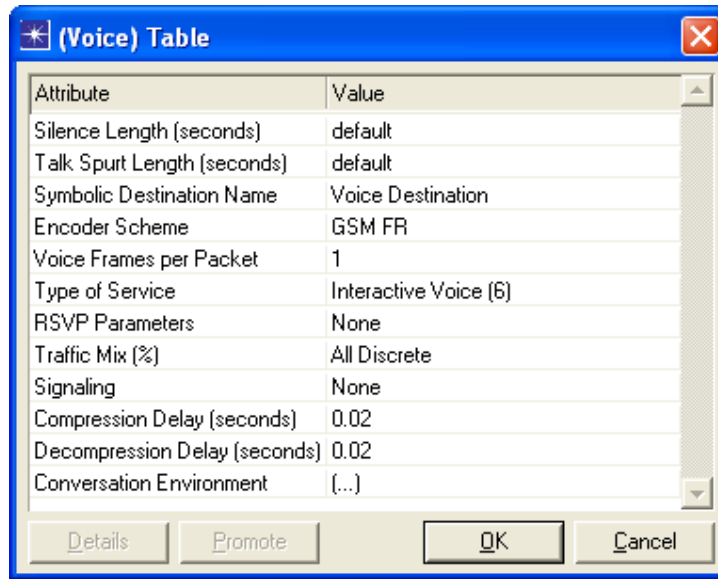

Figure 4-19: Application Definitions - Voice Application Options

After the “GSM Quality and Silence Suppressed” is selected, all the settings of this particular application can be edited by clicking the “Edit...” option. Figure 4-20 shows the settings table for the voice application. In this case, all these settings are kept as default values except the “Signaling”, which should be set to “SIP” as SIP server is used in this research project.



Attribute	Value
Silence Length (seconds)	default
Talk Spurt Length (seconds)	default
Symbolic Destination Name	Voice Destination
Encoder Scheme	GSM FR
Voice Frames per Packet	1
Type of Service	Interactive Voice (6)
RSVP Parameters	None
Traffic Mix (%)	All Discrete
Signaling	None
Compression Delay (seconds)	0.02
Decompression Delay (seconds)	0.02
Conversation Environment	(...)

Figure 4-20: Application Definitions - Voice settings Table

In the same way, more applications that will be used in this project can be defined. In this research project, six application definitions have been configured including tree VoIP applications (using different CODECs), Email, FTP and Web browsing. Figure 4-21 lists the six application definitions. These application definitions then can be used to configure profiles which eventually will be used in the network models.

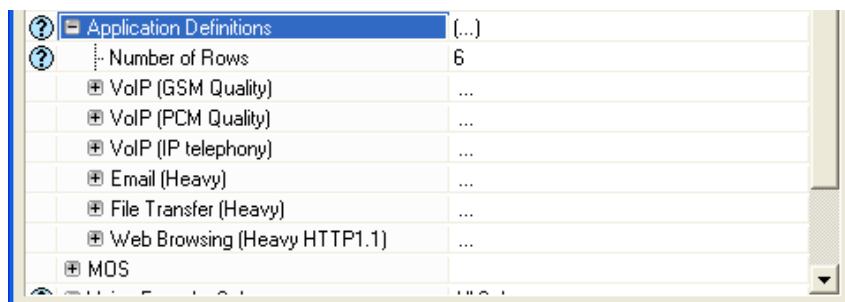

Application Definition	Value
Application Definitions	(...)
Number of Rows	6
VoIP (GSM Quality)	...
VoIP (PCM Quality)	...
VoIP (IP telephony)	...
Email (Heavy)	...
File Transfer (Heavy)	...
Web Browsing (Heavy HTTP1.1)	...
MDS	...

Figure 4-21: Application Definitions

4.2.2 Profiles configuration

A profile is used to model typical application usage of a user or workstation. It normally contains a set of applications, which can be specified when, how long, and how often these applications are typically used. In this research project, only two profiles are configured for the two UMTS workstations. To configure the profile definitions, open the Profile Definition attributes Editor. Figure 4-22 shows how to add one or more profiles into the Profile Definition.

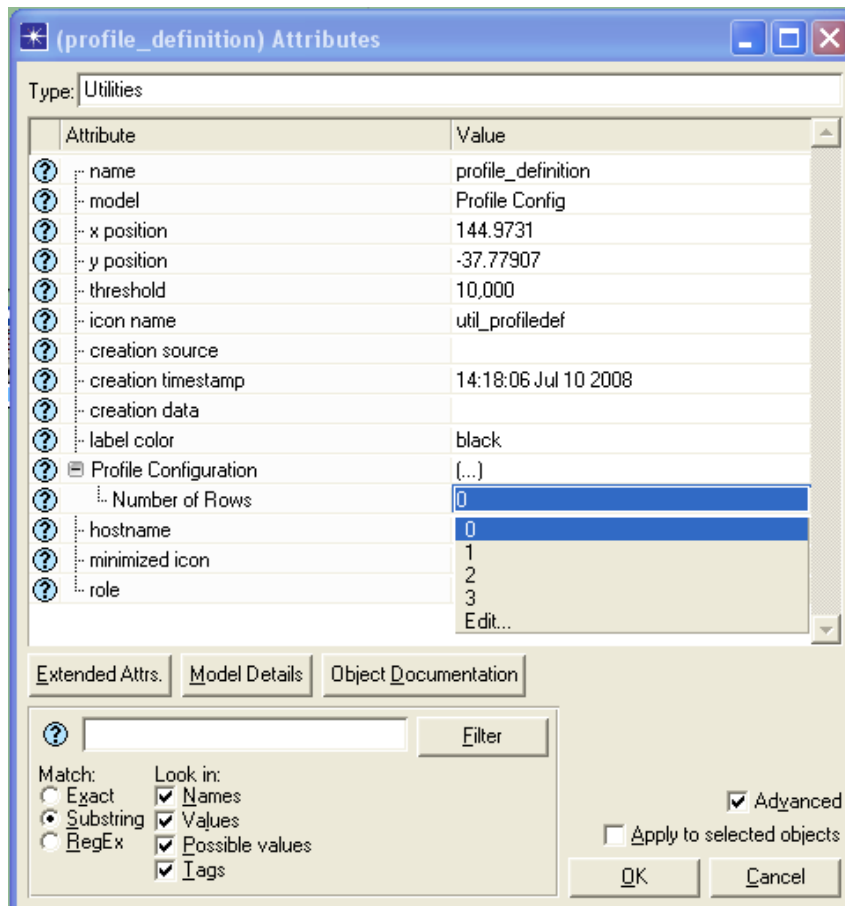

Figure 4-22: Profile Definitions - Adding a new profile

The first profile is named UE0 to present the users of these profiles (as shown in Figure 4-23), and the second one will be named UE1. But for the second profile, no applications will be added in this scenario.

Figure 4-23 also lists the profile’s time-related attributes. Every profile can be repeatedly run during a simulation. The time-related attributes define how the profile will be run in a simulation. In this research project, each profile just runs once in every simulation, so the “Repeatability” attribute is set to “Once at Start Time” and the “duration” is set to “End of Simulation”.

It may take some time for the whole network to get converged. Before that, the applications should not be started. The “Start Time” attribute is used to control the start time of the profile in which the applications are. In this case, it is set to “uniform (120, 140)”, which will start the profile between 120 seconds and 140 seconds after the simulation started.

The “Operation Mode” attributes determines how the applications in a profile will be run when there is more than one application in it. They can be run either at the same time (Simultaneous Mode) or one by one (Serial Model). In this case, only one application is added in the profile project, so the profile “Operation Mode” can be set to either “Simultaneous” or “Serial”. In this research project, more applications will be added in different scenarios which will be created by duplicating this scenario. The applications will be run at the same time to investigate the impact on the VoIP applications from other applications. For that reason, the “Operation Mode” is set to “Simultaneous”.

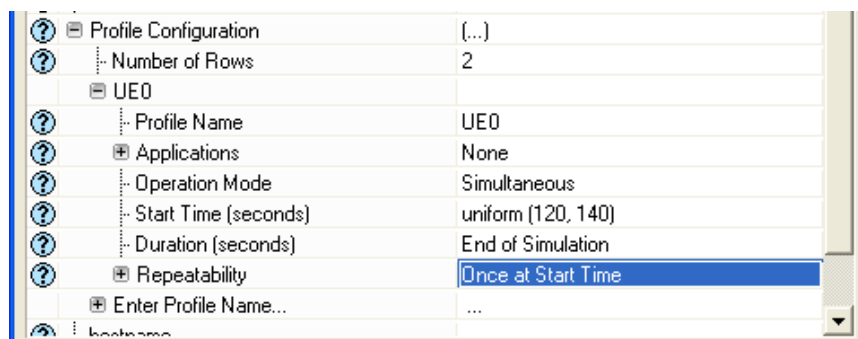

Figure 4-23: Profile Definitions - Profile time-related attributes

Inside a profile, one or more applications can be configured (Figure 4-24). In this scenario only one application is added (more applications will be added in other scenarios).

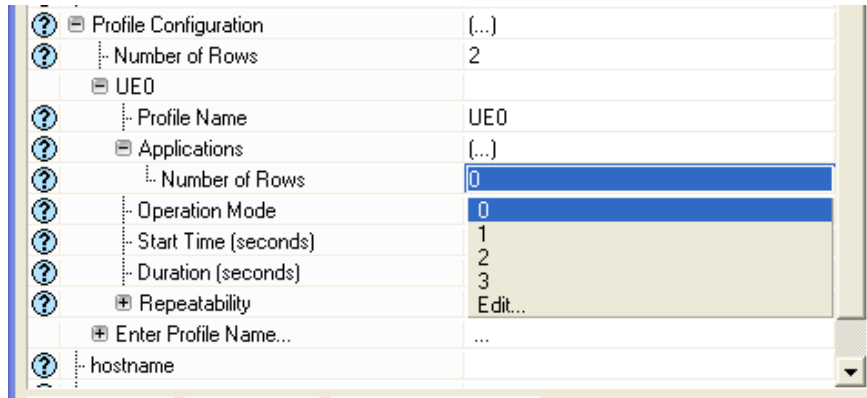

Figure 4-24: Profile Definitions - Adding an application into a profile

These applications can only be chosen from the application definitions that have been previously configured. Figure 4-25 shows the list of available applications in this research project. In this scenario, VoIP (GSM Quality) has been selected.

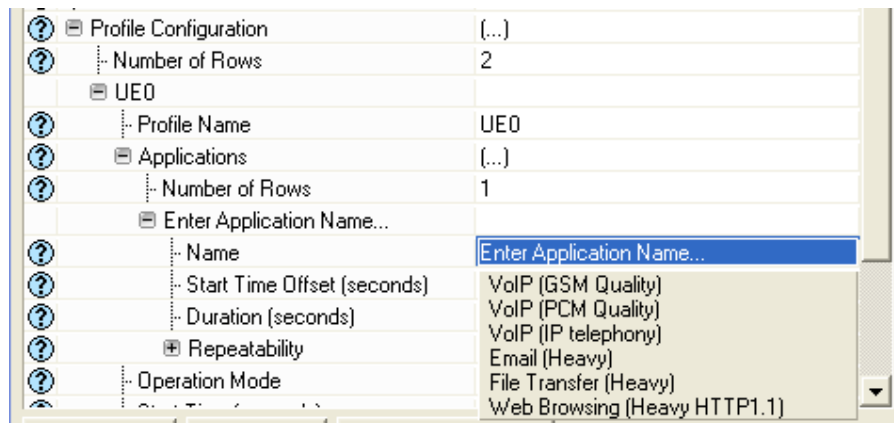

Figure 4-25: Profile Definitions - Choosing the application to be added

Similar to the profiles, every application also has some time-related attributes (as shown in Figure 4-26). In this case, the profile is in “Simultaneous” mode, so the “Start Time Offset” refers to the offset of the first instance of the application, from the start of the profile. It is set to “constant (0)”, so the application can start as soon as the profile starts.

In this scenario, many VoIP calls will be simulated. Each call is set to 2 minutes long and the interval between each call is set to 5 minutes. The application time-related attributes are set accordingly (as shown in Figure 4-26).

UE0		
Profile Name		UE0
Applications		(...)
Number of Rows		1
VoIP (GSM Quality)		
Name		VoIP (GSM Quality)
Start Time Offset (seconds)		constant (0)
Duration (seconds)		constant (120)
Repeatability		(...)
Inter-repetition Time (seconds)		constant (300)
Number of Repetitions		Unlimited
Repetition Pattern		Serial
Operation Mode		Simultaneous
Start Time (seconds)		uniform (120, 140)

Figure 4-26: Profile Definitions - Application time-related attributes

4.2.3 Application deployment

To run all these defined applications in a simulation, they have to be deployed in the actual network models.

Most applications here are server-client applications, while the VoIP application is a little bit different. The calling and called party in a VoIP application are in the same position except in the call establish stage. In Opnet, VoIP applications are configured in the same way, like server-client applications. The “calling party” is configured like a client and the “called party” is treated as a server. In this project, the UE0 is considered as the calling party and the UE1 is going to be the called party.

In this project, three servers need to be configured, and the SIP server is also configured as both SIP server and Email server. To configure a server, open the server’s “attribute editor” dialog, under the “applications” group, the “application: supported service” is the where applications can be added to indicate that the server should provide these services (as shown in Figure 4-27). Similar methods can be used to configure the other servers. The FTP server is configured to support FTP service; the Web server is configured to support Web service; the SIP server is configured to support Email service; and the UE1 is configured to support all the three VoIP applications that have been defined in the Application Definitions (as shown in Figure 4-28).

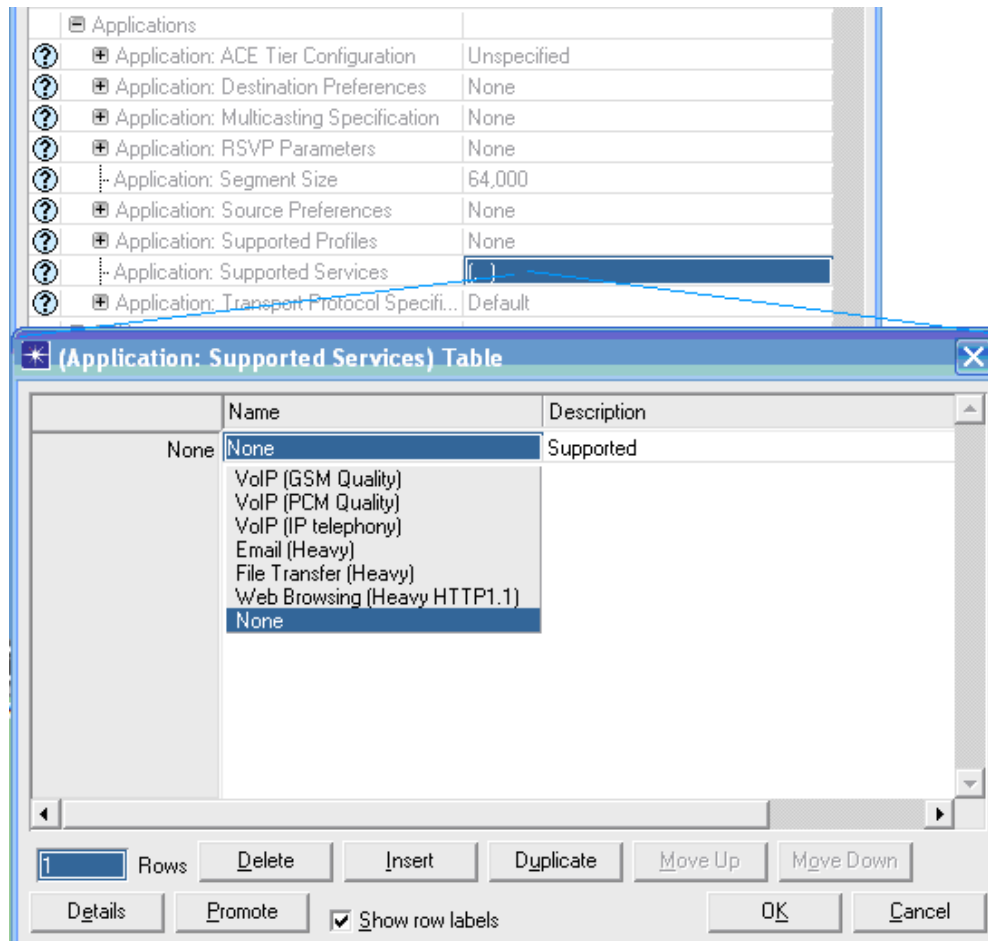

Figure 4-27: Serve supported service configuration

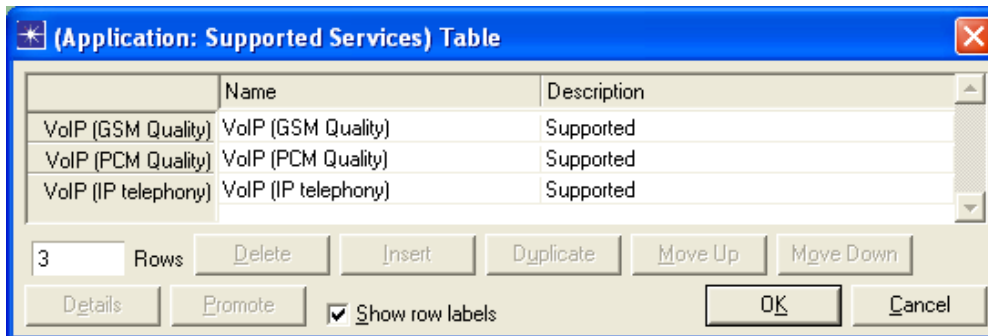

Figure 4-28: UE1 supported services

Beside this, the SIP server needs to be configured to support SIP proxy service which is not an application defined in the Applications Definitions. To configure that, in the

server’s “attribute editor” dialog, under “SIP”, the “proxy Service” should be “Enabled” (as shown in Figure 4-29).

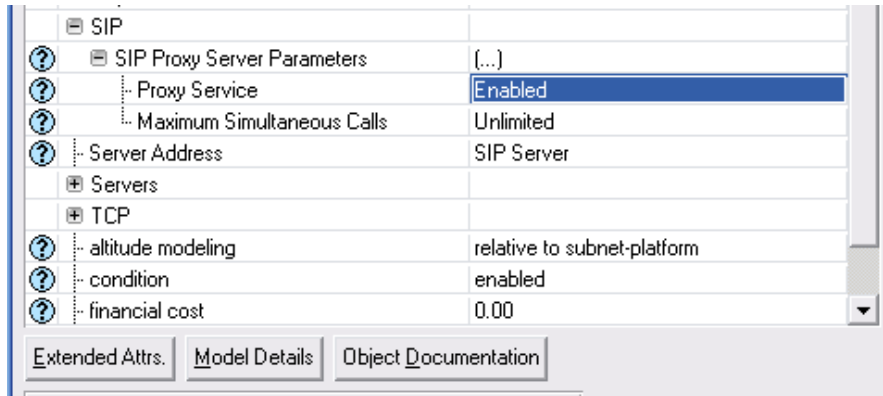

Figure 4-29: Enabling the SIP Server

Finally, the UMTS workstations should be configured to start the applications in the simulation. Again, in the “Attributes editor” dialog, under the “Applications”, add a new profile in “Application: Supported Profiles” (as shown in Figure 4-30). UE0 and UE1 are configured with their own profiles in “Profile Definitions”. In this scenario, the UE1 profile does not have any applications configured. Applications can be added in later on in other scenarios, which are duplicated from this scenario. In this way, only the Profile Definitions need to be changed in other scenarios.

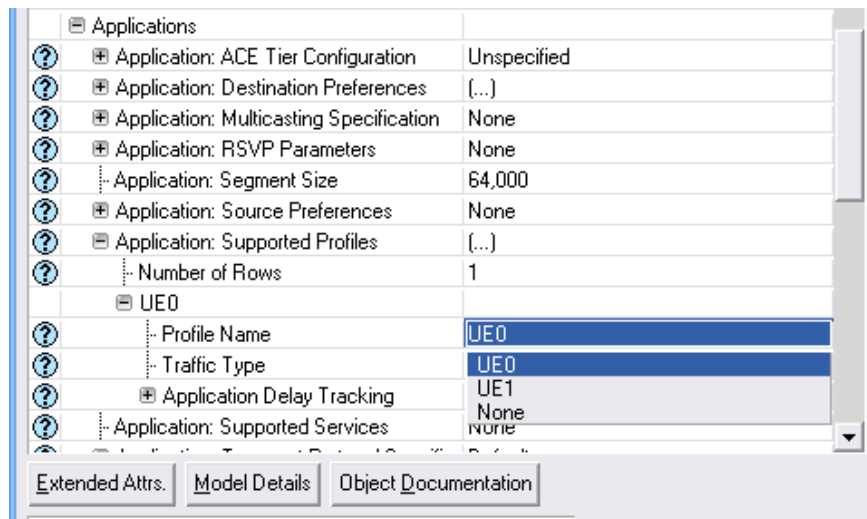

Figure 4-30: UE0 supported profile

4.2.4 Running the simulation

The final step before running the simulation is to choose DES (Discrete Event Simulation) statistics. Open the DES “choose results” dialog by clicking the “choose individual statistics...” in the “DES” menu. There are three different statistics: Global Statistics, Node Statistics and Link Statistics. There are more detailed statistics available for selection (as shown in Figure 4-31). In this project, selected global statistics are Email, FTP, Http, IP, RTP, SIP and Voice. The selected nodes statistics are RTP, server Email, server FTP, server Http, Voice called party and Voice calling party.

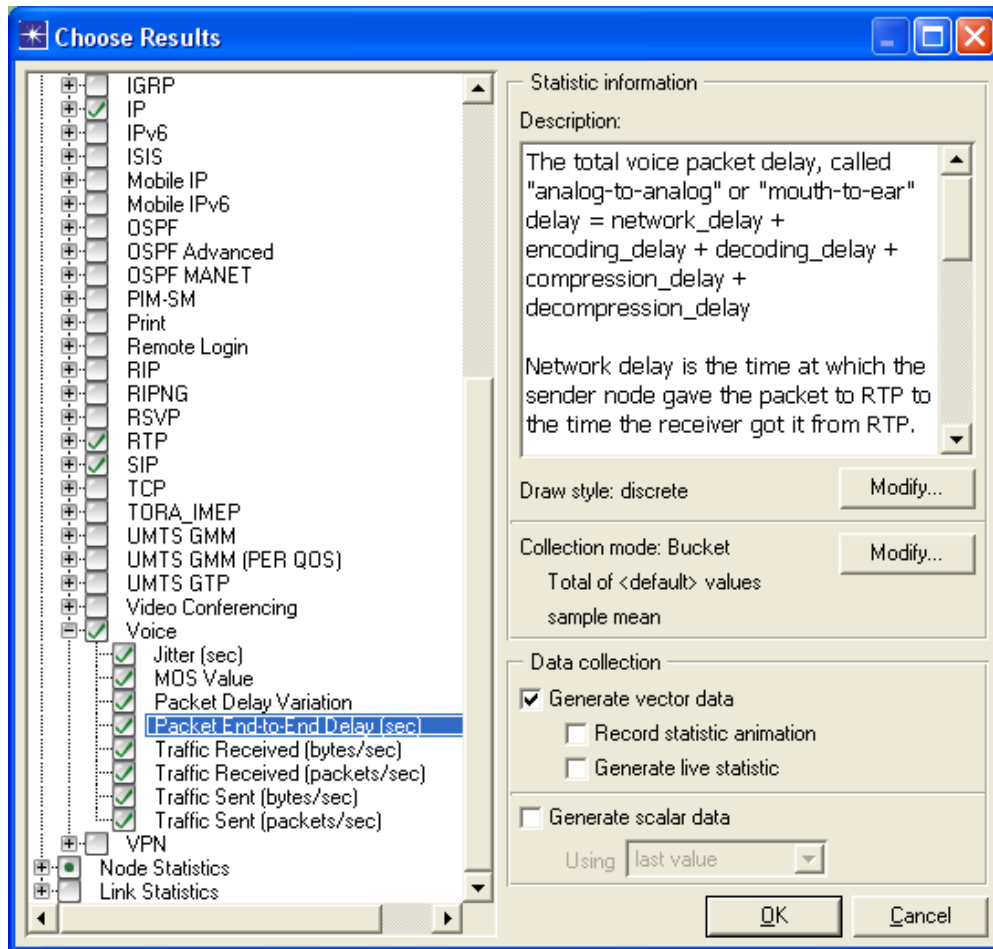

Figure 4-31: Choose DES Results

After that, all the configurations for the scenario have been completed. The simulation can be run to collect the results.

The initial simulation was duplicated and different CODECs schemes were used for the VoIP calls. Three CODECs (GSM FR, G.711 and G.729A) were used. Simulations were run for each CODEC with the frame size varied to 4 ms, 10 ms, 20 ms and 30 ms. Additional simulations were run with the number of voice frames per packet varied. The same network was used for each of the different simulations.

4.3 E-model implementation

The E-Model is a well established voice transmission quality prediction and measurement model for telephone networks. It provides an objective method of assessing the end-to-end transmission quality of a telephone connection and is intended to assist telecommunication service providers with network planning and performance monitoring (Clark, 2003). The E-Model is based on the concept that “psychological factors on the psychological scale are additive” (ITU-T, 2006). In other words, it assumes that each impairment factor which affects a voice call can be computed separately, even so this does not imply that such factors are uncorrelated, but only that their contributions to the estimated impairments are separable (Cole and Rosenbluth, 2001). The resulting score is the transmission rating R factor, a scalar measure that ranges from 0 (poor) to 100 (excellent). R factor values below 60 are not recommended (R. G. Cole, 2001). The result of any calculation with the E-model in a first step is a transmission rating factor R, which combines all transmission parameters relevant for the considered connection. This rating factor R is composed of:

$$R = R_o - I_s - I_d - I_{eff} + A \quad (4-1)$$

where R_o represents the basic signal-to-noise ratio (SNR); I_s represents the combination of all impairments which occur more or less simultaneously with the voice signal; I_d represents the impairments caused by delay; I_{eff} represents impairments caused by low bit rate CODECS; and A is the advantage factor, that corresponds to the user allowance due to the convenience in using a given technology. Once the used codec is well-known, the I_e factor can be decided, so it only needs to capture network (delay and loss) statistics for estimating the speech quality by means of the R factor expression (4-1).

This is the main reason in adopting the E-Model as a measurement tool. The E-Model not only takes in account the transmission statistics (transport delay and network packet loss), but it also considers the voice application characteristics, like the codec quality, codec robustness against packet loss and the late packet discard (Carvalho, 2005).

Table 4-1 lists the G.107 default values for E-Model Inputs (ITU-T, 2006).

Titles		E-Model Inputs (G.107 Default)		
Electric Circuit Noise Referred to at 0 dBr point	Nc	(-70)	-70.0	dBm0p
Noise Floor	Nfor	(-64)	-64.0	dBmp
Room Noise (Send)	Ps	(35)	35.0	dB(A)
Room Noise (Receive)	Pr	(35)	35.0	dB(A)
Send Loudness Rating	SLR	(8)	8.0	dB
Receive Loudness Rating	RLR	(2)	2.0	dB
Sidetone Masking Rating	STMR	(15)	15.0	dB
D-factor (Receive)	Dr	(3)	3.0	
Listener's Sidetone Rating	LSTR	(=STMR+Dr)	18.0	dB
D-factor (Send)	Ds	(3)	3.0	
Mean One-Way Delay	T	(0)	0.0	ms
Absolute Delay from (S) to (R)	Ta	(=T)	0.0	ms
Round-Trip Delay	Tr	(=2T)	0.0	ms
Talker Echo Loudness Rating	TELRLR	(65)	65.0	dB
Weighted Echo Path Loss	WEPL	(110)	110.0	dB
Quantizing Distortion Units	qdu	(1)	1.0	
Equipment Impairment Factor	Ie	(0)	0.0	
Packet-loss Robustness Factor	Bpl	(1)	1.0	

Packet-loss Probability	Ppl	(0)	0.0	%
Burst Ratio	BurstR	(1)	1	
Expectation Factor	A	(0)	0.0	

Table 4-1: E-Model Inputs (G.107 Default)

In this research, the values of T, Ta, Tr, Ie, Bpl and Ppl will be decided by the simulation environment and results.

By applying these default values of the E-Model parameters and the simulation environment parameters and results to equation (4-1), the R factor can be calculated.

4.3.1 Basic signal-to-noise ratio (SNR)

The basic signal-to-noise ratio Ro is defined by (ITU-T, 2006):

$$R_o = 15 - 1.5 (SLR + N_o) \quad (4-2)$$

The term SLR stands for Send Loudness Rating, according to Table 4-1, the default values is 8 dB.

The term No [in dBm0p] is the power addition of different noise sources (ITU-T, 2006):

$$N_o = 10 \log \left[10^{\frac{N_c}{10}} + 10^{\frac{N_{os}}{10}} + 10^{\frac{N_{or}}{10}} + 10^{\frac{N_{fo}}{10}} \right] \quad (4-3)$$

Nc [in dBm0p] is the sum of all circuit noise powers, all referred to the 0 dBr point (ITU-T, 2006).

Nos [in dBm0p] is the equivalent circuit noise at the 0 dBr point, caused by the room noise Ps at the send side (ITU-T, 2006):

$$N_{os} = P_s - SLR - D_s - 100 + 0.004(P_s - OLR - D_s - 14)^2 \quad (4-4)$$

Where $OLR = SLR + RLR$. In the same way the room noise Pr at the receive side is transferred into an equivalent circuit noise Nor [in dBm0p] at the 0 dBr point (ITU-T, 2006).

$$Nor = RLR - 121 + Pre + 0.008(Pre - 35)^2 \quad (4-5)$$

The term Pre [in dBm0p] is the "effective room noise" caused by the enhancement of Pr by the listener's sidetone path (ITU-T, 2006):

$$Pre = Pr + 10 \log \left[1 + 10^{\frac{(10-LSTR)}{10}} \right] \quad (4-6)$$

Nfo [in dBm0p] represents the "noise floor" at the receive side (ITU-T, 2006):,

$$Nfo = Nfor + RLR \quad (4-7)$$

With $Nfor$ usually set to -64 dBmp (ITU-T, 2006).

The default values of SLR , Ps , Ds , OLR , RLR , Pr and $LSTR$ can be found in Table 4-1. By putting these values into equations (4-2) – (4-7), the value of Ro can be calculated:

$$Ro = 94.77153423 \quad (4-8)$$

4.3.2 Simultaneous impairment factor, I_s

The factor I_s is the sum of all impairments which may occur more or less simultaneously with the voice transmission. The factor I_s is divided into three further specific impairment factors (ITU-T, 2006):

$$I_s = I_{olr} + I_{st} + I_q \quad (4-9)$$

I_{olr} represents the decrease in quality caused by too-low values of OLR and is given by (ITU-T, 2006):

$$I_{olr} = 20 \left[\left\{ 1 + \left(\frac{X_{olr}}{8} \right)^8 \right\}^{\frac{1}{8}} - \frac{X_{olr}}{8} \right] \quad (4-10)$$

Where:

$$X_{olr} = OLR + 0.2(64 + N_o - RLR) \quad (4-11)$$

By applying the default values from Table 4-1, I_{olr} can be calculated:

$$I_{olr} = 0.440280564 \text{ dB} \quad (4-12)$$

The impairment factor I_q represents impairment caused by quantizing distortion (ITU-T, 2006):

$$I_q = 15 \log[1 + 10^Y + 10^Z] \quad (4-13)$$

Where

$$Y = \frac{R_o - 100}{15} + \frac{46}{8.4} + \frac{G}{9} \quad (4-14)$$

$$Z = \frac{46}{30} - \frac{G}{40} \quad (4-15)$$

And

$$G = 1.07 + 0.258[37 - 15 \log(qdu)] + [37 - 15 \log(qdu)]^2 \quad (4-16)$$

The following is the result of applying the default values to the above equations:

$$I_q = 0.974105153 \quad (4-17)$$

The factor I_{st} represents the impairment caused by non-optimum sidetone (ITU-T, 2006):

$$I_{st} = 12 \left[1 + \left(\frac{STMR\sigma}{6} \right)^8 \right]^{\frac{1}{8}} - 28 \left[1 + \left(\frac{STMR\sigma+1}{19.4} \right)^{35} \right]^{\frac{1}{35}} - 13 \left[1 + \left(\frac{STMR\sigma-3}{33} \right)^{13} \right]^{\frac{1}{13}} + 29 \quad (4-18)$$

Where:

$$STMRO = -10 \log \left[10^{\frac{STM}{10}} + e^{\frac{T}{4}} 10^{\frac{TELR}{10}} \right] \quad (4-19)$$

By applying Equation (4-12) and (4-17) to Equation (4-9), the following equation can be drawn:

$$I_s = 1.414385717 + I_{st} \quad (4-20)$$

Where I_{st} can be calculated by using Equation (4-18) and (4-19) once the value of T is determined.

4.3.3 Delay impairment factor, I_d

I_d , the impairment factor representing all impairments due to delay of voice signals is further subdivided into the three factors I_{dte} , I_{dle} and I_{dd} (ITU-T, 2006):

$$I_d = I_{dte} + I_{dle} + I_{dd} \quad (4-21)$$

The factor I_{dte} gives an estimate for the impairments due to Talker Echo. The factor I_{dle} represents impairments due to Listener Echo. The factor I_{dd} represents the impairment caused by too-long absolute delay T_a , which occurs even with perfect echo cancelling. These three factors depend on the delay T .

4.3.4 Effective Equipment Impairment Factor, I_{e-eff}

The packet-loss dependent Effective Equipment Impairment Factor I_{e-eff} is derived using the codec-specific value for the Equipment Impairment Factor at zero packet-loss I_e and the Packet-loss Robustness Factor B_{pl} . With the Packet-loss Probability P_{pl} , I_{e-eff} is calculated using the formula (ITU-T, 2006):

$$I_{e-eff} = I_e + (95 - I_e) \frac{P_{pl}}{\frac{P_{pl}}{BurstR} + B_{pl}} \quad (4-22)$$

When packet loss is random $BurstR = 1$.

According to ITU-T Recommendation G.113, I_e and B_{pl} are varied from different codec schemes. Table 4-2 and Table 4-3 give Provisional planning values for the equipment impairment factor, I_e , and for packet-loss robustness factor, B_{pl} .

Codec type	Reference	Operating rate (kbit/s)	I_e value
PCM	G.711	64	0
ADPCM	G.726, G.727	40	2
	G.721, G.726, G.727	32	7
	G.726, G.727	24	25
	G.726, G.727	16	50
LD-CELP	G.728	16	7
		12.8	20
CS-ACELP	G.729	8	10
	G.729-A + VAD	8	11
VSELP	IS-54	8	20
ACELP	IS-641	7.4	10
QCELP	IS-96A	8	21
RCELP	IS-127	8	6
VSELP	Japanese PDC	6.7	24
RPE-LTP	GSM 06.10, full-rate	13	20
VSELP	GSM 06.20, full-rate	5.6	23
ACELP	GSM 06.60, enhanced full-rate	12.2	5
ACELP	G.723.1	5.3	19
MP-MLQ	G.723.1	6.3	15

Table 4-2: Provisional planning values for the equipment impairment factor, I_e

Codec	Packet size	PLC type	Ie	Bpl
G.723.1+VAD	30 ms	Native	15	16
G.729A + VAD	20 ms (2 frames)	Native	11	19.0
GSM-EFR	20 ms	Native	5	10
G.711	10 ms	None	0	4.3
G.711	10 ms		0	25.1

Table 4-3: Provisional planning values for the equipment impairment factor, Ie, and for packet-loss robustness factor, Bpl

Combine the equations (4-8), (4-20), (4-21) and (4-22), the E-model R factor can be calculated once the delay time and the codec scheme have been decided in the simulation.

5 Results and Analysis

As part of this research work, a paper has been presented at the Australasian Telecommunications Networking and Application Conference (ATNAC) 2008. In the paper (Appendix A) titled “Performance Evaluation of VoIP Services using Different CODECs over a Hybrid UMTS network”, end-to-end delay is used as the key element to evaluate the performance of VOIP services that use different CODEC schemes, over a hybrid network that includes a UMTS network segment.

To get more comprehensive performance evaluation, the E-model will be used and the R factor will be calculated for all of the different scenarios. According to the analysis in Chapter 4, the end-to-end delay, packet loss and the CODEC scheme are needed to calculate the R factor for a particular VoIP call.

5.1 End-to-end delay results

Three different CODECs were used in this research. For each CODEC, 4ms, 10ms and 20ms frame sizes were used and for each frame size the Frames per Packet is set from one to six. Totally, fifty-four simulations were carried out and the statistical data was collected.

For the G.711 CODEC, very high packet-loss rates and end-to-end delay were found in the G.711 CODEC simulations and this result was not anticipated. It may be considered in future research. Figure 5-1 shows the results of one G.711 CODEC simulation. It shows that the packet loss rate is about 50 percent. Many other G.711 CODEC schemes (with different frame size and frame per packet) had similar results.

In this research, the simplified E-model will not be applied on those CODEC schemes with unexpected high packet-loss rates.

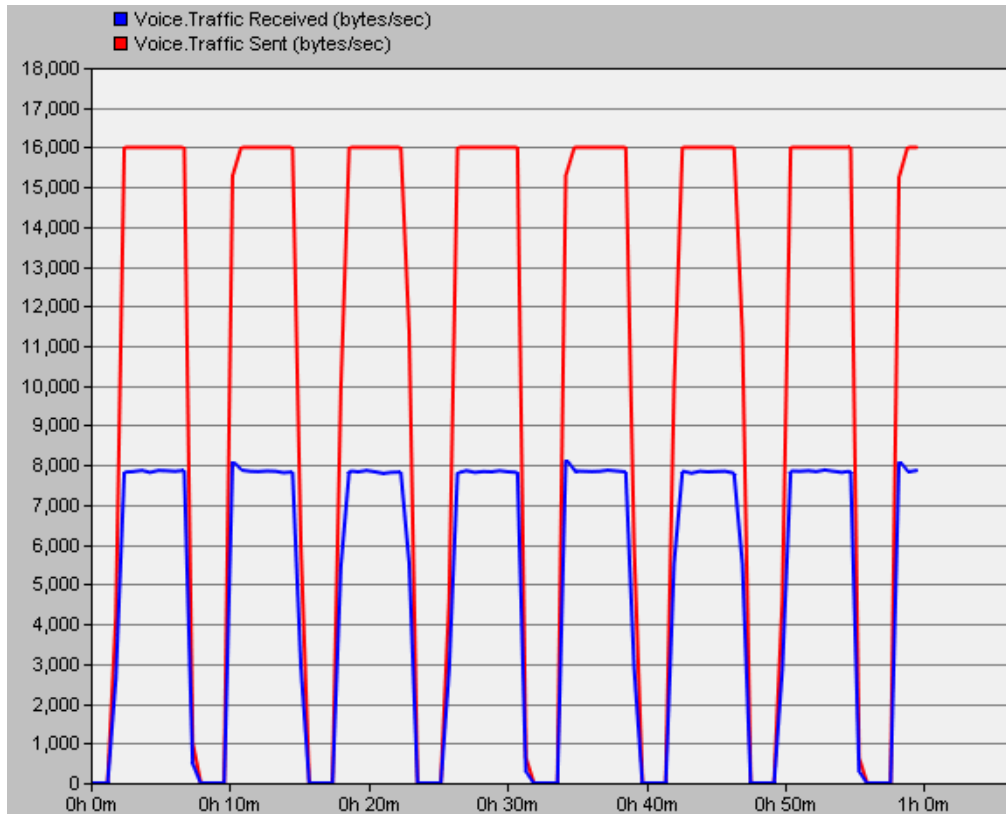

Figure 5-1: Packet loss for G.711

To have a good understanding of the results for different CODEC schemes, Figures were generated using Opnet. Figure 5-2 shows the end-to-end delay for all of the GSM-FR CODEC schemes. In this figure, the sample mean values of end-to-end delay are used. From this figure, GSM-FR with 4ms frame size and 6 frames per packet have the least end-to-end delay. For GSM-FR with 10ms or 20 ms frame sizes, the more frames in one packet, the more end-to-end delay.

For G.729A CODEC, the results are very similar to the results from GSM_FR. Figure 5-3 shows the end-to-end delay for all the G.729A CODEC schemes.

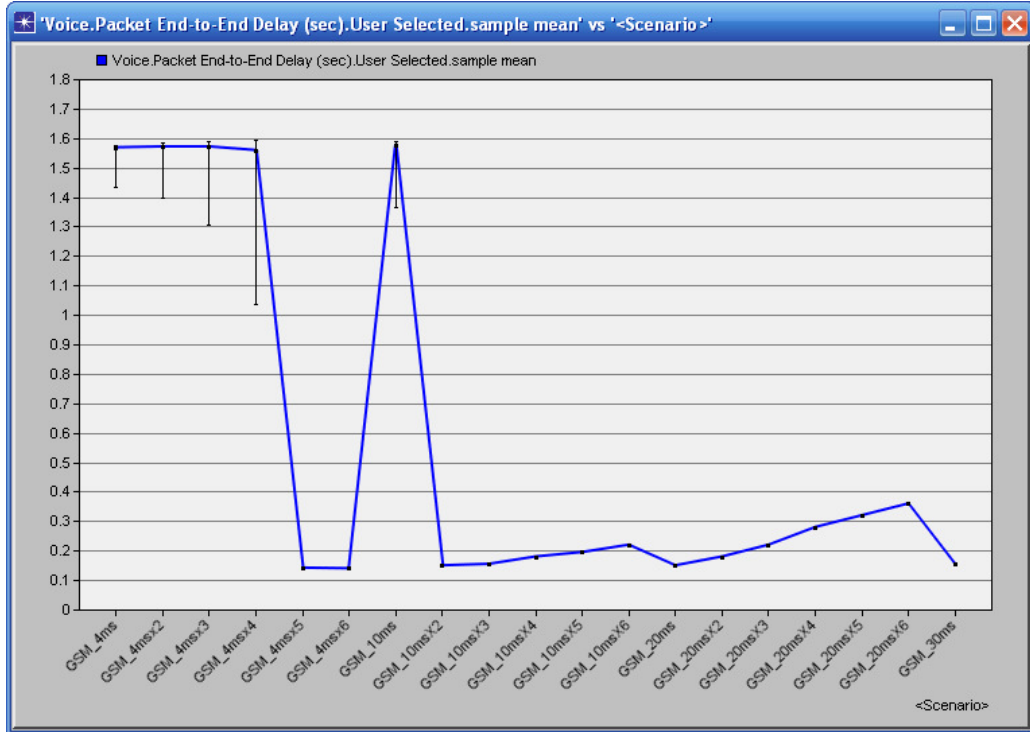

Figure 5-2: GSM-FR End-to-end delays

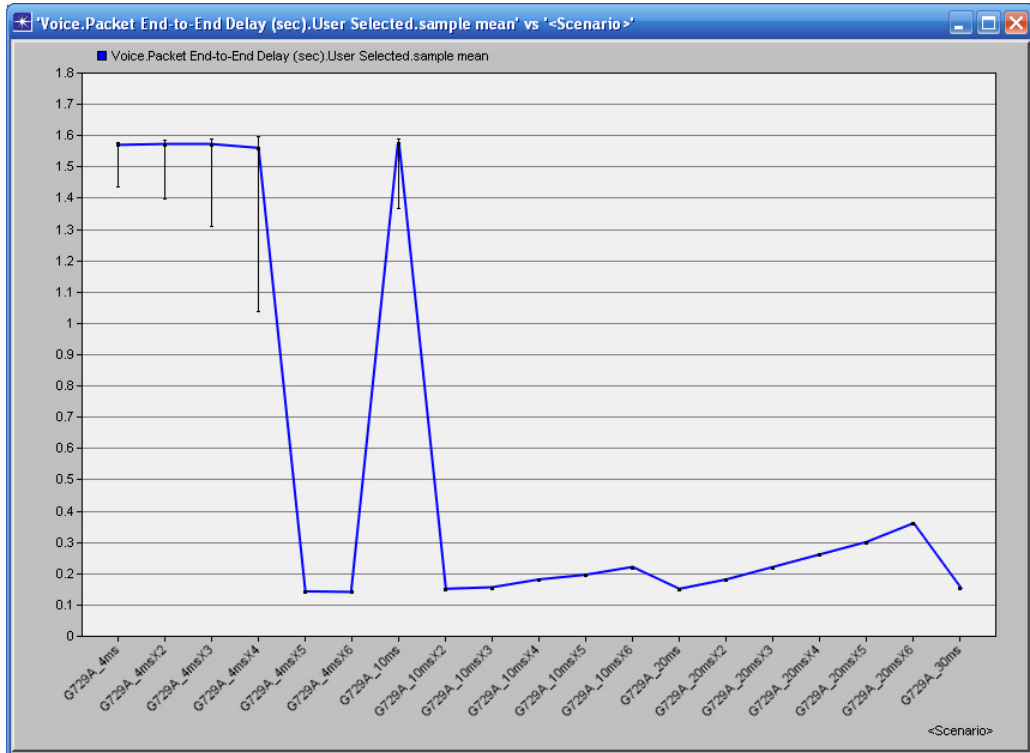

Figure 5-3: G729A End-to-end delays

All the end-to-end delay results were collected and put in the following table (Table 5-1). These results will be applied in the E-Model analysis.

Frames per Packet		1	2	3	4	5	6
G.711	4ms	1568	1572	1572	NA	NA	1580
	10ms	1575	NA	1559	NA	1625	NA
	20ms	NA	NA	NA	NA	NA	NA
G.729A	4ms	1568	1572	1571	1562	141.998	140.001
	10ms	1575	149.996	155.002	180.001	195.011	220.002
	20ms	150.002	180.002	220.002	260.001	300.000	359.998
GSM-FR	4ms	1568	1572	1571	1560	141.998	140.001
	10ms	1575	149.996	155.001	180.001	195.012	220.002
	20ms	150.002	180.002	220.002	280.001	320.000	359.998

Table 5-1: End-to-end delays

5.2 E-Model R factor results

In Chapter 4, the E-model calculation was simplified. To use the simplified E-model, it only needs the end-to-end delay, packet loss rate and CODEC scheme.

In this research work, the simulation of the hybrid UMTS network is only used for the VoIP calls, and the bandwidth is more than enough for VoIP calls, the packet-loss rate was almost zero in all the simulation scenarios. Figure 5-4 is the results of one simulations, it shows that the all the voice packets were delivered.

Based on this, to calculate the E-Model R factor for all the simulation scenarios, the packet-loss rate will be assumed as zero.

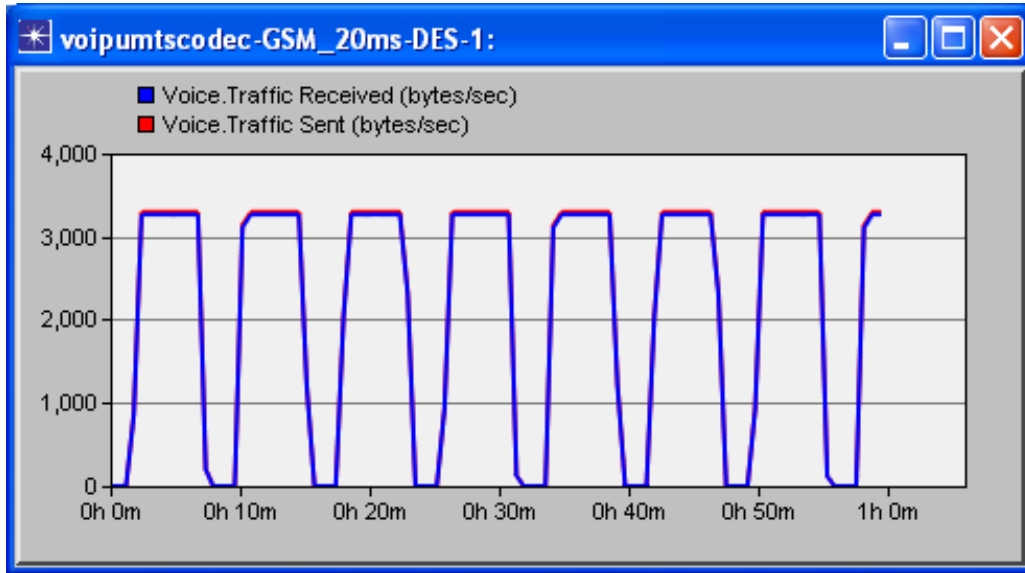

Figure 5-4: Packet loss rate

By using the equations in Chapter 4 and the results in Table 5-1, the E-Model R factors for all the simulation scenarios can be calculated. The R factors are showing in Table 5-2.

Frames per Packet		1	2	3	4	5	6
G.711	4ms	34.2	34.2	34.2	NA	NA	34.2
	10ms	34.2	NA	34.3	NA	34.0	NA
	20ms	NA	NA	NA	NA	NA	NA
G.729A	4ms	23.2	23.2	23.2	23.3	78.8	78.8
	10ms	23.2	78.5	78.4	76.8	75.4	72.3
	20ms	78.5	76.8	72.3	66.8	61.7	55.0
GSM-FR	4ms	29.2	29.2	29.2	29.3	84.8	84.8
	10ms	29.2	84.5	84.4	82.8	81.4	78.3
	20ms	84.5	82.8	78.3	70.2	65.3	61.0

Table 5-2: R factor values

From Table 5-2, G.711 is not suitable for this simulation environment. The over-all voice quality for GSM-FR is better than G.729A, although they have almost the same end-to-end delay times.

The simulation results showed that there is a correlation between the end-to-end delay, the CODEC used and the number of voice frames in each VoIP packet. The G.711 CODEC was found to be unsuitable for VoIP over a hybrid UMTS network. The possible reason is because G.711 is a much higher bit rate than G.729 and GSM-FR. The G.711 is also a waveform based codec, whereas G.729 and GSM_FR are based on speech models with long term prediction, hence they are less susceptible to short term anomalies. Further research needs to be done on G.711. For the GSM-FR and G.729A CODECs the best results were achieved for a 4 ms voice frame size and six voice frames for each VoIP packet. Overall, the simulations showed that for a hybrid UMTS network, the selection of CODEC, the voice frame size and how the voice traffic is packaged into VoIP packets will significantly affect the overall VoIP call quality.

5.3 Results Analysis

The Mean Opinion Score (MOS) is a value that represents the quality for a voice call. MOS is the output value of subjective quality metrics. ITU-T Recommendation G.107 (ITU-T, 2006) provides a method to obtain estimated MOS values for conversational situations. By using that method, the R factor can be converted to MOS rating in ranges from 1 (worst case) to 5 (excellent quality). The conversion is done by computing the relationship between R factor and MOS rating.

For $R < 6.5$: $MOS = 1$

For $6.5 \leq R \leq 100$: $MOS = 1 + 0.035R + R(R - 60) / (100 - R) \cdot 7 \cdot 10^{-6}$ (5-1)

For $R > 100$: $MOS = 4.5$

By applying this formula to the R values listed in Table 5-2, the MOS values for the simulation results can be calculated. Table 5-3 shows the simulation MOS results.

Frames per Packet		1	2	3	4	5	6
G.711	4ms	1.79	1.79	1.79	NA	NA	1.79
	10ms	1.79	NA	1.8	NA	1.79	NA
	20ms	NA	NA	NA	NA	NA	NA
G.729A	4ms	1.35	1.35	1.35	1.36	3.98	3.98
	10ms	1.35	3.97	3.96	3.90	3.84	3.70
	20ms	3.97	3.90	3.70	3.44	3.19	2.84
GSM-FR	4ms	1.58	1.58	1.58	1.58	4.19	4.19
	10ms	1.58	4.18	4.18	4.13	4.08	3.96
	20ms	4.18	4.13	3.96	3.61	3.37	3.15

Table 5-3: MOS values

Table 5-3 represents the results identified in the simulations as MOS values. As discussed in Section 5.2, the G.711 CODEC was found to be unsuitable for VoIP over a hybrid UMTS network. For the GSM-FR and G.729A CODECs achieved the best simulation results for a 4 ms voice frame size and six voice frames for each VoIP IP packet. The more voice frames in each VoIP IP packet, the less IP packet headers are transmitted which makes the voice transmission less bandwidth-consuming and less time-consuming since there are less IP packets to be processed.

Some comparable results were found by Passito et al. (Passito et al., 2005) who implemented the E-Model for voice over 802.11b networks with IPSec (Internet Protocol Security). Figure 5-5 (Passito et al., 2005) shows the test environment.

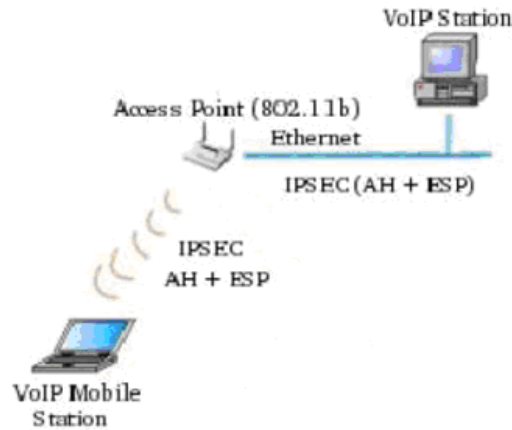

Figure 5-5: A Hybrid wireless network for VoIP

The scenario presented by Passito et al. is comparable to the simulations done in this research where UMTS was used rather than WiFi. The approach taken by Passito et al. was further developed and the model used in this research was enhanced to include multiple network segments and UMTS.

The test results were presented in Figure 5-6 (Passito et al., 2005). For the network without security MOS was equal to 4.27, VPN (Virtual Private Network) with AES (Advanced Encryption Standard) gave MOS equal to 3.92 and for 3DES (Triple Data Encryption Algorithm), MOS was equal to 3.55.

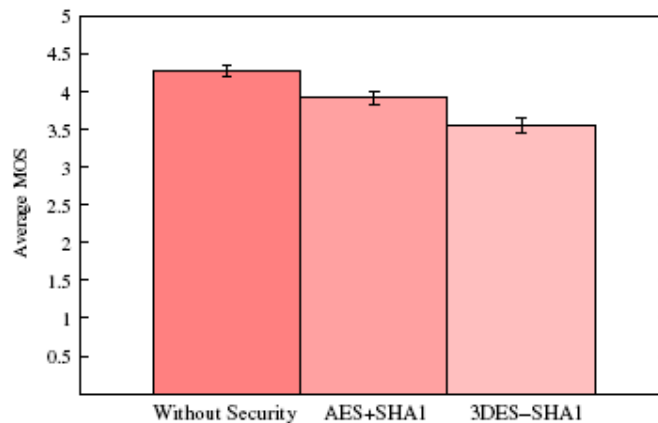

Figure 5-6: Average MOS values for security combinations

Comparing these results with the MOS values in Table 5-3, a MOS value for the network without security is higher than all the MOS values in Table 5-3, but only

slightly higher than top MOS value. The MOS values from Table 5-3 are comparable to or higher than the other MOS values in Figure 5-6.

Considering that the simulation environment reported in this thesis is more developed than the one used by Passito et al. (Passito et al., 2005), and therefore the results should be considered based upon general outcomes rather than through a direct comparison of the approach taken. The results show similar trends and outcomes to that when a WiFi network is substituted for a UMTS network. The result comparison shows that changing the frame size and frame number per IP packet helps to improve the overall performance if the right combination is used in the particular network segment.

In this research, the Internet segment used was a best effort network and QoS protocols were not used. Opnet Modeler simulates the Internet segment as a traditional best effort IP network rather than a VoIP QoS protocol enabled network. Recently MPLS and other protocols were developed to provide better service transmission across the digital network backbone.

6 Conclusions

The objectives set out for this research were to implement a VoIP E-Model technique over a hybrid UMTS network and then to compare the results with results presented in the literature for other network types and configurations. The research included development of a model and simulation environment that could be used to gain results suitable for analysis. The research objectives were successfully achieved.

The research presented in this thesis was the subject of a conference paper presented at the ATNAC 2008 conference held in Adelaide, Australia during December 2008 and the paper is presented in Appendix A.

6.1 Research review

The research aim to model VoIP over a hybrid UMTS network and to identify an improved approach to applying the ITU-T Recommendation G.107 (E-Model) to understand possible QoS outcomes for the hybrid UMTS network was successfully achieved.

The research included Modeling the hybrid UMTS network and carrying out simulations of different traffic types transmitted over the network. The traffic characteristics were analysed and compared with results from the literature. VoIP traffic was modelled over the hybrid UMTS network and the VoIP traffic was generated to represent different loads on the network from light to medium and heavy VoIP traffic.

The VoIP over hybrid UMTS network traffic results were characterized and used in conjunction with the E-Model to identify VoIP QoS outcomes. The E-Model technique was simplified and the results achieved were compared with results for other network types highlighted in the literature.

The research identified an approach that permits accurate Modeling of VoIP QoS over a hybrid UMTS network. Accurate results should allow network design to facilitate new approaches to achieving an optimal network implementation for VoIP.

During the research Opnet Modeler v14 was used to simulate a hybrid UMTS network and VoIP calls were simulated utilising different CODECs over the hybrid UMTS network. The VoIP QoS E-model was simplified and used to evaluate the performance of the VoIP services.

The VoIP packet end-to-end delays and packet loss were examined for each configuration. The simplified E-model algorithm proposed in this research was applied to each VoIP call configuration to evaluate the VoIP call performance.

The simulation results showed that there is a correlation between the end-to-end delay, the CODEC used and the number of voice frames in each VoIP packet. The G.711 CODEC was found to be unsuitable for VoIP over a hybrid UMTS network. For the GSM-FR and G.729A CODECs, the best results were achieved for a 4 ms voice frame size and six voice frames for each VoIP packet.

Overall, the simulations carried out showed that for a hybrid UMTS network the selection of CODEC, the voice frame size and how the voice traffic is packaged into VoIP packets will affect the overall VoIP call quality. The effective setup of an operational network should take into account the network type over which VoIP sessions will occur. For the hybrid UMTS network, the results presented in this thesis should be a guide to achieving better network performance.

6.2 Thesis Summary

Initial investigation into the various technologies and standards for the VoIP applications and UMTS networks were detailed in Chapter 2. The chapter starts from the conception of VoIP and its technologies, followed by the discussion of the requirements for IP networks to support the real-time applications including VoIP. After, the detailed architecture of VoIP is discussed together with the most common protocols and standards. As the extension of the requirements of VoIP, QoS comes up and some QoS related parameters have been mentioned. To predict and measure QoS, the E-Model has been introduced. Finally, Chapter 2 also presents a brief overview of UMTS over which the QoS of VoIP will be investigated and discussed as the major part of this research work.

Chapter 3 defined the objectives and scope of this research. The limitations and assumptions of this research were described. Chapter 3 also described the overall path taken to achieve the final goal of this research. It served as the guideline for the research work carried out.

Chapter 4 provided a detailed review of the research work carried out. The research was divided into three parts: (1) the E-Model simplification, (2) VoIP over hybrid UMTS network modeling and (3) simulation. Chapter 4 began with development in the simulation environment of the hybrid UMTS network and implementation of the VoIP service across the hybrid UMTS network model. After the model development and testing within Opnet Modeler, preliminary data from initial simulations was used with the E-Model to gain a greater understanding of how the E-Model may be used for VoIP over a hybrid UMTS network. Finally, the E-Model calculations were simplified to suit this research environment. Different test scenarios were discussed, and simulations were carried out to generate statistical data for each of the test scenarios.

The research data collected and analysed as part of the simulations is presented and discussed in Chapter 5. Some of the results presented in Chapter 5 were presented at a conference (ATNAC 2008) and the paper is provided in Appendix 1.

6.3 Research work summary

In this research, Opnet Modeler was used to simulate a hybrid UMTS network and VoIP calls were simulated with different voice CODECs using the hybrid UMTS network. The E-Model was simplified and used to evaluate the performance of the VoIP services.

The VoIP packet end-to-end delays and packet loss were examined through analysis of results obtained from simulations of each scenario with different configurations and parameter values. The simplified E-Model was applied to each simulation scenario to evaluate the VoIP call QoS performance.

The simulation results showed that there is a correlation between the end-to-end delay, the voice CODEC used and the number of voice frames in each VoIP IP packet. The G.711 CODEC was found to be unsuitable for VoIP over a hybrid UMTS network. For

the GSM-FR and G.729A CODECs the best results were achieved for a 4 ms voice frame size and six voice frames for each VoIP IP packet.

Overall, the simulations showed that for a hybrid UMTS network the selection of voice CODEC, the voice frame size and how the voice traffic is packaged into VoIP IP packets will affect the overall VoIP call quality.

6.4 Conclusion

This research has successfully developed a hybrid UMTS network model and simulation environment that can be used to gain simulation results suitable for analysis. The E-Model calculations have been analysed and simplified to suite the simulation environment used in this research work. Simulation scenarios have been tested and test results have been collected. The simulation results have been analysed by using the simplified E-Model calculations.

In summary, the objectives of this research stated in Chapter 3 were achieved. The limitations and assumptions made in Chapter 3 highlighted the need for future research into real-world and objective testing on VoIP over hybrid UMTS networks. Also, the finding of VoIP over hybrid UMTS networks using G.711 CODEC in this research needs more investigation using alternative simulation environments.

7 Future Research Work

The research findings and conclusions highlight the possibility for future research.

- In this research, the G.711 CODEC was found to perform very differently to GSM-FR and G.729A CODECs. Most of the simulations using the G.711 CODEC result in similar voice traffic with packet-loss rates about 50%. The future research work on the particular topic will include finding the reason for the large packet loss rate for G.711.
- Another research topic could focus on the G.729A and GSM-FR CODEC schemes. In this research, in some simulation scenarios, the end-to-end delays are too large for these CODECs compared with the similar scenarios and other CODECs. This could be another research project.

The limitations and assumptions made in Chapter 3 also highlight the need for future research.

- The network models and protocols provided and used within the Opnet Modeler simulation application were considered as reasonable and suitable for the research. Similar simulations could be done with other simulation applications to compare the results with the results from Opnet Modeler. Even real-world testing could be done to evaluate the simulation results.
- The E-Model was not designed and developed for the modern IP networks. Some characteristics of the modern IP networks were not taken into account when the E-Model was developed. In order to get better results, the E-Model parameters should be re-calculated to reflect current IP network characteristics. More research on E-Model calculations will be needed to achieve more reliable and accurate results.
- The E-model calculation formula uses parameters that depend on the physical environment. In the Opnet Modeler simulation environment, some parameters are set to default values. To more accurately reflect the real world system, the

simulation environment needs to be modified to match a particular network in the real world.

- The E-Model is additive. It simply adds the impairment factors for multiple systems, to calculate the R factor, while VoIP networks are known to be non-additive and non-linear. Other QoS measurement tools could be used to improve the accuracy of the results.

8 Reference

- AL-MOUHAMED, M. A., TOKER, O., IQBAL, A. & ISLAM, M. S. (2005) Evaluation of real-time delays for networked telerobotics. *Industrial Informatics, 2005. INDIN '05. 2005 3rd IEEE International Conference on.*
- ASH, J., LI, C., D'SOUZA, K., WAI SUM, L., VAN DER LINDE, H. & YUNG, Y. (2004) AT&T's MPLS OAM architecture, experience, and evolution. *Communications Magazine, IEEE, 42, 100-111.*
- BAKSHI, M. (2006) VoIP / Multimedia over WiMAX (802.16). *Department of Computer Science & Engineering. St. Louis, Washington University in St. Louis.*
- BREWER, O. T., ARUN, A. & FOSTER, M. S. (2006) Integrated Services Provisioning Across Cryptographic Boundaries. *Military Communications Conference, 2006. MILCOM 2006. IEEE.*
- CARVALHO, L. (2005) An E-Model Implementation for Speech Quality Evaluation in VoIP Systems. *the 10th IEEE Symposium on Computers and Communications.*
- CARVALHO, L., MOTA, E., AGUIAR, R., LIMA, A. F. & DE SOUZA, J. N. (2005) An E-model implementation for speech quality evaluation in VoIP systems. *Computers and Communications, 2005. ISCC 2005. Proceedings. 10th IEEE Symposium on.*
- CHANDRASEKHARAN, S., ARNOLD, S. & GOPAL, R. (2008) Situational awareness with real time IP applications over next generation packet processing satellites. *Military Communications Conference, 2008. MILCOM 2008. IEEE.*
- CISCO (2002) Cisco Mobile Exchange (CMX) Solution Guide. *Chapter 2: Overview of GSM, GPRS, and UMTS.*
- CISCO (2003) Cisco IP Telephony Solution Reference Network Design Guide. Cisco Systems, Inc.
- CISCO (2007) SIP Architecture. IN SIP, O. O. (Ed.). Cisco Systems, Inc.
- CLARK, A. D. (2003) Modeling the Effects of Burst Packet Loss and Recency on Subjective Voice Quality. *IPtel 2001 Workshop.*
- COLE, R. G. & ROSENBLUTH, J. H. (2001) Voice over IP Performance Monitoring. *ACM SIGCOMM Computer Communication Review, 31, 9-24.*
- DANSEREAU, R. M., JIN, S. & GOUBRAN, R. A. (2006) Reducing Packet Loss in CBC Secured VoIP using Interleaved Encryption. *Electrical and Computer Engineering, 2006. CCECE '06. Canadian Conference on.*
- EL-MARAKBY, R. & HUTCHISON, D. (1998) Scalability improvement of the real-time control protocol (RTCP) leading to management facilities in the Internet. *Computers and Communications, 1998. ISCC '98. Proceedings. Third IEEE Symposium on.*
- FINEBERG, V. (2002) A practical architecture for implementing end-to-end QoS in an IP network. *Communications Magazine, IEEE, 40, 122-130.*
- FOX, G. & UYAR, A. (2001) Survey of Collaborative Tools and Systems. *Department of Computer Science. Tallahassee, Florida State University.*

-
- GHIASI, S. & PO-KUAN, H. (2006) Probabilistic delay budgeting for soft realtime applications. *Quality Electronic Design, 2006. ISQED '06. 7th International Symposium on*.
- HAWWAR, Y., FARAG, E., VANAKAYALA, S., PAULS, R., YANG, X., SUBRAMANIAN, S., SADHANALA, P., YANG, L., WANG, B., LI, Z., CHEN, H., LU, Z., CLARK, D., FOSKET, T., MALLELA, P., SHELTON, M., LAURENS, D., SALAUN, T., GOUGEON, L., AUBOURG, N., MORVAN, H., LE HENAFF, N., PRAT, G., CHARLES, F., CREACH, C., CALVEZ, Y. & BUTEL, P. (2006) 3G UMTS wireless system physical layer: baseband processing hardware implementation perspective. *Communications Magazine, IEEE, 44, 52-58*.
- HERNANDEZ-VALENCIA, E. J. & CHUAH, M. C. (2000) Transport delays for UMTS VoIP. *Wireless Communications and Networking Conference, 2000. WCNC. 2000 IEEE*.
- HU, L., PENG, J. & XIN, Y. (2008) Experimental Research about the Impact of IEEE 802.1P on Real-Time Behavior of Switched Industrial Ethernet. *Computing, Communication, Control, and Management, 2008. CCCM '08. ISECS International Colloquium on*.
- INFORMATION SCIENCES INSTITUTE, U. O. S. C. (1981) RFC 791 - Internet Protocol.
- ISLAM, M. M., POSE, R. & KOPP, C. (2005) MAC layer support for real-time traffic in a SAHN. *Information Technology: Coding and Computing, 2005. ITCC 2005. International Conference on*.
- ITU-T (1999) Recommendation G.109: Definition of categories of speech transmission quality.
- ITU-T (2003a) ITU-T Recommendation G.114: One-way transmission time.
- ITU-T (2003b) ITU-T Recommendation P.800.1: Mean Opinion Score (MOS) Terminology.
- ITU-T (2004) E-Model Tutorial.
- ITU-T (2006) ITU-T Recommendation G.107: The E-model, a computational model for use in transmission planning.
- JAE-CHANG, K. (1994) Real-Time VirtualClock: a new network traffic control mechanism for real-time communications. *TENCON '94. IEEE Region 10's Ninth Annual International Conference. Theme: Frontiers of Computer Technology. Proceedings of 1994*.
- JIN, Y. & KRIARAS, I. (2000) Migration to all-IP based UMTS networks. *3G Mobile Communication Technologies, 2000. First International Conference on (Conf. Publ. No. 471)*.
- KOBAYASHI, K., HIRANO, M., NARITA, A. & ISHII, H. (2003) IP network designer: interface for IP network simulation. *Mixed and Augmented Reality, 2003. Proceedings. The Second IEEE and ACM International Symposium on*.
- KOTH, A. M., EL-SHERBINI, A. & KAMEL, T. (1996) A new interoperable management model for IP and OSI architectures. *AFRICON, 1996., IEEE AFRICON 4th*.
- LI, F. (2001) Quality and Reliability of Telephone Calls on the Internet Pre-study Report. *School of Computer Science and Communication. Stockholm, KTH - Royal Institute of Technology*.
-

-
- LIERS, F. & MITSCHLE-THIEL, A. (2005) UMTS data capacity improvements employing dynamic RRC timeouts. *Personal, Indoor and Mobile Radio Communications, 2005. PIMRC 2005. IEEE 16th International Symposium on.*
- LOFFELMANN, G. (2000) TCP/IP over UMTS. *Institute of Communications and Radio_Frequency Engineering.* Vienna, Vienna University of Technology.
- MACKNIGHT, R. B., TIMANS, P. J., TAY, S. P. & NENYEI, Z. (2004) RTP application and technology options for the sub-45 nm nodes. *Advanced Thermal Processing of Semiconductors, 2004. RTP 2004. 12th IEEE International Conference on.*
- MASON, P. C., CULLEN, J. M. & LOBLEY, N. C. (1996) UMTS architectures. *Mobile Communications Towards the Next Millenium and Beyond, IEE Colloquium on.*
- MATUSZ, P., WOZNIAK, J. & KAMINSKI, K. (2004) On performance of MAC-c/sh in UMTS. *3G Mobile Communication Technologies, 2004. 3G 2004. Fifth IEE International Conference on.*
- NET, N. S. (2008) VoIP Network Connectivity. IN VOIP, N. L.-. (Ed.). Nig's Net.
- NETWORKS, T. (1998) Voice Over Packet Version 2.2 SPEY005. Tology Networks, A Texas Instruments.
- OPNET (2009) OPNET Website. Bethesda, MD, OPNET Technologies.
- OUDELAAR, J. (1994) Evolution towards UMTS. *Personal, Indoor and Mobile Radio Communications, 1994. Wireless Networks - Catching the Mobile Future., 5th IEEE International Symposium on.*
- PASSITO, A., MOTA, E., AGUIAR, R., CARVALHO, L., MOURA, E., BRIGLIA, A. & BIDS, I. (2005) Using an E-model implementation to evaluate speech quality in voice over 802.11b networks with VPN/IPSec. *Wireless Communications, Networking and Mobile Computing, 2005. Proceedings. 2005 International Conference on.*
- PERKINS, C. & CROWCROFT, J. (2000) Effects of interleaving on RTP header compression. *INFOCOM 2000. Nineteenth Annual Joint Conference of the IEEE Computer and Communications Societies. Proceedings. IEEE.*
- PROCTOR, T. K. (2003) Evolution to 3G services: provision of 3G services over GERAN (GSM/EDGE radio access network). *3G Mobile Communication Technologies, 2003. 3G 2003. 4th International Conference on (Conf. Publ. No. 494).*
- PROTOCOLS (2008) The H.323 Protocols Suite. IN CELLULAR-PROTOCOLS.GIF (Ed.). Protocols.com.
- PROULX, E. (2007) A typical SIP call process without involve of any servers. IN SIP, A. I. T. (Ed.).
- R. G. COLE, J. H. R. (2001) Voice over IP Performance Monitoring. ACM SIGCOMM.
- SCHULZRINNE, H. (2003) RTP: A Transport Protocol for Real-Time Applications (RFC3550).
- SEUNGCHUL, P. (2006) DiffServ Quality of Service Support for Multimedia Applications in Broadband Access Networks. *Hybrid Information Technology, 2006. ICHIT '06. International Conference on.*
- UPKAR VARSHNEY, A. S., MATT MCGIVERN, AND CHRISTI HOWARD (2002) Voice Over IP. *COMMUNICATIONS OF THE ACM.*

-
- VARSHNEY, U. & MALLOY, A. D. (2001) Improving the dependability of wireless networks using design techniques. *Local Computer Networks, 2001. Proceedings. LCN 2001. 26th Annual IEEE Conference on.*
- VOIPFORO (2006) H323 Communication. IN H323-COMMUNICATION.GIF (Ed.). VoIPForo.com.
- WALLINGFORD, T. (2005) *Switching to VoIP*, O'Reilly, ISBN: 0-596-00868-6, Section 9.1.1.1.
- WALTERMANN, M. & RAAKE, A. (2008) Towards a new E-Model impairment factor for linear distortion of narrowband and wideband speech transmission. *Acoustics, Speech and Signal Processing, 2008. ICASSP 2008. IEEE International Conference on.*
- WENYU, J., KOGUCHI, K. & SCHULZRINNE, H. (2003) QoS evaluation of VoIP end-points. *Communications, 2003. ICC '03. IEEE International Conference on.*
- YUFEI, W., ZHENG, W. & LEAH, Z. (2001) Internet traffic engineering without full mesh overlaying. *INFOCOM 2001. Twentieth Annual Joint Conference of the IEEE Computer and Communications Societies. Proceedings. IEEE.*
- ZUREK, E. E., LEFFEW, J. & MORENO, W. A. (2002) Objective evaluation of voice clarity measurements for VoIP compression algorithms. *Devices, Circuits and Systems, 2002. Proceedings of the Fourth IEEE International Caracas Conference on.*

Appendix A

Performance Evaluation of VoIP Services using Different CODECs over a UMTS Network

Jianguo Cao, Mark Gregory
School of Electrical and Computer Engineering
RMIT University Melbourne, VIC 3000 Australia
Email: j.cao@student.rmit.edu.au , mark.gregory@rmit.edu.au

***Abstract* - In this paper, we evaluate the performance of Voice over Internet Protocol (VOIP) services that use different compression and decompression (CODEC) schemes, over a hybrid network that includes a Universal Mobile Telecommunications System (UMTS) network segment. We focus on the VoIP transmission end-to-end delay. We found that different CODECs provide very different results depending on the hybrid network. The research found that for VoIP services to operate over a hybrid network including a UMTS network segment, with an end-to-end delay comparable to that of circuit switched voice service, there is a requirement for careful comparison and design on choosing the CODEC scheme.**

I. INTRODUCTION

In recent years, Voice over Internet Protocol (VoIP) has attracted the attention of the network engineering research and operation communities. The phenomenal growth of VoIP is the result of rapid commercial solutions and network improvements. Other factors include the ongoing decrease in quality differences between existing Public Switched Telephone Networks (PSTN) telephony and VoIP [1] and the increase in bandwidth available to commercial and residential customers over which VoIP may be transported [2].

Most IP networks today were not designed for real-time, delay-sensitive voice or video traffic [3]. Current IP networks only provide a best-effort service and subsequently there is no guarantee that VoIP speech quality will be equivalent to what is provided by the existing PSTN telephony services.

VoIP services in wireless networks, such as UMTS [4], are being progressively implemented. The main benefit of VoIP over a wireless IP network is the mobility that is provided to users. Wireless networks have their own characteristics [5]. It is more challenging when the wireless network is combined with a real-time application's transmission requirement to meet the minimum Quality of Service (QoS). In order to gain a greater understanding of the VoIP transmission QoS, it is necessary to evaluate the performance of VoIP services over the hybrid wireless network.

End-to-end path delay has significant impact on the quality for the real-time delay sensitive VoIP services. In this research, the VoIP packet end-to-end delay will be investigated and analysed.

A number of encoder decoders (CODEC) are in common use today and each has different characteristics [6]. Transmission results may also vary when one CODEC is used and the information being transmitted is arranged into frames of different sizes. This effect is most noticeable when the segmentation of the transport stream occurs into Real-time Transport Protocol (RTP) packets. Generally, one or more voice frames can be put into one RTP packet. Figure 1 shows that RTP packets are then put into UDP packets and finally into IP packets prior to transmission across the network. The IP packets are encapsulated into MAC frames and transmitted from node to node. Delays are accumulated during the processing that occurs at each node across the path from source to destination.

The rest of the paper is structured as follows: (1) background information about VoIP, CODECS, QoS and end-to-end delay is provided in the next section, (2) in Section 3 the simulation environment for VoIP over UMTS and different CODEC schemes is discussed, (3) preliminary results are presented in Section 4, and (4) conclusions are presented in Section 5.

II. VoIP

In this section the literature review on VoIP, CODECS, QoS and end-to-end delay is provided.

A. CODEC

A CODEC is an algorithm used to encode and decode the voice stream. Since the voice stream is analog, it needs to be digitized so it can be transmitted over the Internet. Once it reaches the other end it needs to be decoded to restore the analog stream. There are a variety of different ways this encoding and decoding can be done.

Three popular CODECS are used and discussed in this paper. The CODECS are G.711, G729A and GSM. CODEC uses different algorithms to compress and decompress the voice stream and each CODEC will contribute a processing delay to the overall end-to-end delay [6].

B. VoIP Protocols

In a typical VoIP system, the voice stream is digitalized into voice frames. The voice frames are encapsulated and transmitted in RTP packets which are managed using RTCP which provides stream control and statistical information [7].

Signalling protocols have been introduced to provide overall management of VoIP calls. In the recent years, the Session Initiation Protocol (SIP) [8] has become very popular and is playing a major role in advancing VoIP. Figure 1 shows the protocol relationships in a SIP based VoIP system.

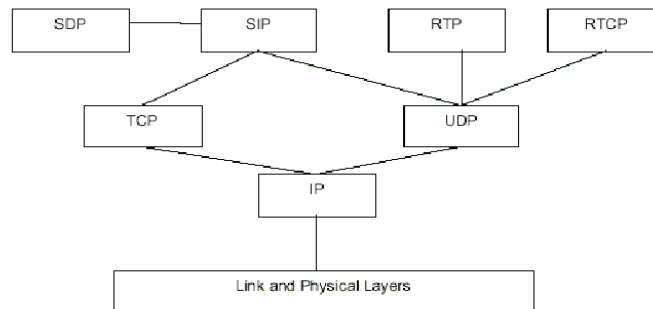

Figure 1. Protocol hierarchy for a SIP based VoIP system

IP packets used to transmit voice not only include the voice data, but also include protocol headers. The protocol headers are IP, UDP and RTP. An IPv4 header is 20 octets; a UDP header is 8 octets and an RTP header is 12 octets. The total length of this header information is 40 octets (bytes), or 320 bits, and the headers are sent with every packet containing voice data. The addition of headers as part of the encapsulation process adds to the bandwidth requirement for voice transmission.

C. QoS

In a PSTN network, phone calls are provided with a fixed bandwidth [9]. In a best effort packet network bandwidth is not fixed and may change over time [10]. When bandwidth drops in a best effort network for a voice call data packets may be lost and this causes voice call quality degradation. To achieve a minimum voice call QoS in a packet network it is necessary to apply a mechanism to control

network parameters. The parameters used for VoIP QoS include end-to-end delay, jitter and packet loss [11]. The total end-to-end delay is the sum of a packet assembly at the source, the network delay and the receiver delay including packet disassembly. Jitter is the variance of packet arrival time due to different processing times and delays across the network [12]. Packet loss has a large effect on VoIP call QoS. Generally, a packet loss rate of 5% will annoy users and a higher packet loss rate can cause users to terminate a call. Packet loss may occur when there is congestion on the transmission path which causes the router buffers to overflow. The stability of the network heavily influences the packet loss rate [12].

D. End-to-end delay

Delay in VoIP networks is caused by propagation delay and processing delay [11].

Propagation delay is a characteristic of the transmission medium which may be fibre optic, copper medium or radio frequency.

Processing delay is caused by the network devices that handle VoIP traffic. Processing delay may be affected by the network device capacity and also the current network traffic at each device along a transmission path.

III. HYBRID NETWORK MODEL

A hybrid UMTS model was used to simulate end-to-end delay. The UMTS functionality can be outlined into three groups [13]:

1. User Equipment (UE)
2. UMTS Terrestrial Radio Access Network (UTRAN). UTRAN consists of NodeB and Radio Network Controller (RNC), refer to Figure 2.
3. Core Network. The Core Network comprises two basic nodes: Serving GPRS Support Node (SGSN) and Gateway GPRS Support Node (GGSN). GGSN provides internetworking with external packet switched networks such as IP networks.

In this research work Opnet Modeler 14.0 [14] was used to simulate the hybrid UMTS network and implement VoIP applications across the hybrid network i.e. combination of UMTS and IP network.

A. Simulation Environment

In Opnet Modeler, a simulation scenario was setup as shown in Figure 2.

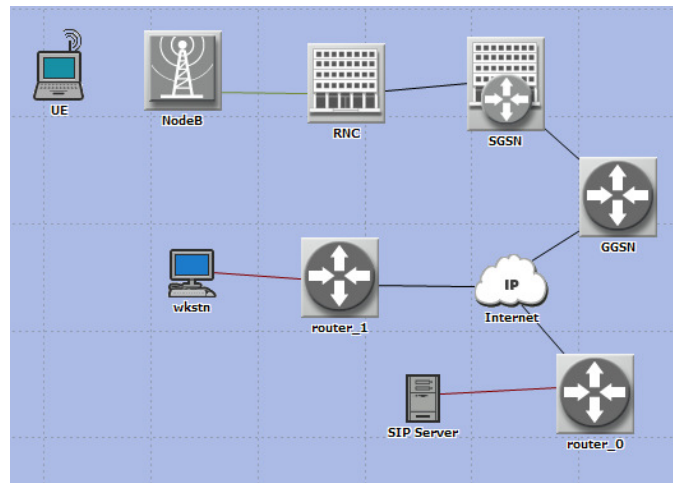

Figure 2. Simulation Environment

As shown in Figure 2 the UE, NodeB, RNC, SGSN and GGSN form a simple UMTS network which is connected to the Internet via the GGSN. A workstation and a SIP server are connected to the Internet

using a router. The SIP Server is used as a signaling server to establish VoIP calls between the UE and the workstation.

B. VoIP and CODEC Schemes

VoIP calls between UE and the workstation were configured and the SIP server was used for call control. The simulation run-time was set to one hour, and during the simulation VoIP calls were made repeatedly with five-minute duration and three minute intervals.

The initial scenario was duplicated and different CODECs schemes were used for the VoIP calls between the UE and the workstation. Three CODECs (GSM FR, G.711 and G.729A) were used. Simulations were run for each CODEC with the frame size varied to 4 ms, 10 ms, 20 ms and 30 ms. Additional simulations were run with the number of voice frames per packet varied. The same network was used for each of the different simulations.

In this research different frame sizes were used for the same CODEC to analyse the relationship between the frame size and the end-to-end delay. Table 1 summarizes the end-to-end delay assumption for each network component. The frame size of a CODEC can effect the NodeB scheduling and Hybrid Automatic Retransmission reQuest (HARQ) delay [15]. For a typical VoIP call, an acceptable end-to-end delay is less than 200 milliseconds.

TABLE I
SUMMARY OF END-TO-END DELAY COMPONENT

Delay component	Delay assumption
Voice encoder	Equal to CODEC frame size
NodeB scheduling + HARQ	Max. 110ms
NodeB ROHC, RLC+MAC processing Downlink propagation	30ms
UE scheduling + HARQ	40ms
UE processing, buffering, etc Uplink propagation	30ms
Backhaul delay (GSN-NodeB)	30ms
IP network delay	About 42ms

Normally the data rate for VoIP is less than 20kbps (except G.711), much smaller than the bandwidth UMTS can provide. If a very small VoIP packet is transferred in each MAC frame (2ms), the total available bandwidth would be under utilized.

As the number of VoIP packet is increased the amount of overhead grows by adding the IP/UDP/RTP headers. Research has been done in an effort to address this situation by aggregating several successively generated voice frames into one VoIP packet in order to improve bandwidth utilization [16].

IV. RESULTS ANALYSIS

In this section the simulation results will be presented and discussed. The simulations carried out were to identify if changes in the number of voice packets and CODECs affected the performance overall. The network configuration as shown in Figure 2 represents a typical network setup for voice calls.

A. Voice Frame Size and End-to-End Delay

In Figure 3, six simulation results are displayed. The results in Figure 3 show that for GSM-FR, G.711 and G.729A with frame size 4ms and 10 ms, the end-to-end delay results are similar, about 1580 ms delay, and not acceptable for VoIP calls. It is concluded that 4ms and 10ms frame sizes are not suitable for VoIP implementation over UMTS networks.

Figure 4 shows the results of GSM-FR with 20 ms and 30 ms frame sizes and Figure 5 shows the results of G.729A with the same frame sizes.

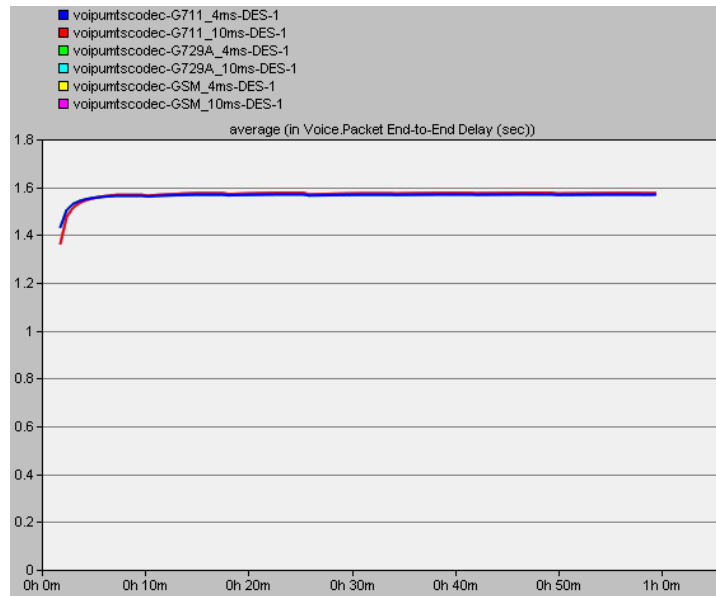

Figure 3. Delay for different CODECs (4ms frame size)

Figure 4 and Figure 5 show similar characteristics. From Figure 4 and Figure 5, it can be said that both GSM-FR and G.729A get less end-to-end delay when they are using 20ms frame sizes than 30 ms frame sizes. The actual end-to-end delay time is very close. Both CODECs are getting about 150ms end-to-end delay for a 20 ms frame size and 155ms end-to-end delay for a 30 ms frame size. The results shown in Figure 4 and Figure 5 are acceptable for VoIP calls.

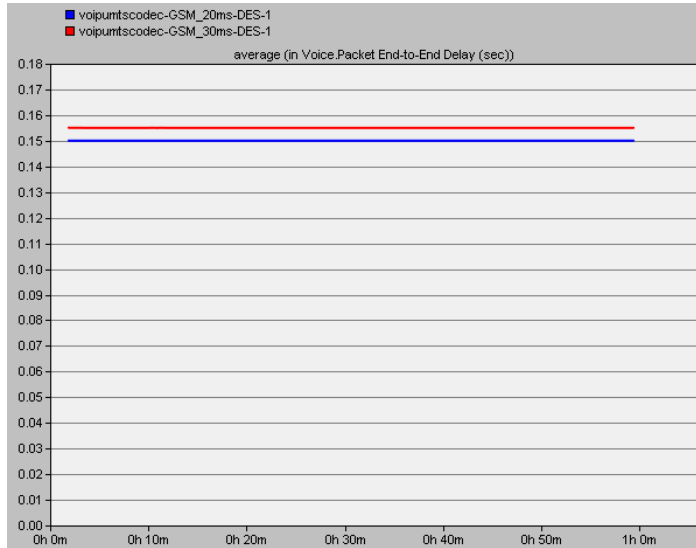

Figure 4. Delay for GSM-FR (20ms and 30ms frame size)

For the G.711 CODEC, the results found were different than that found for the GSM-FR and G.729A CODECs. Very high packet-loss rates were found in the G.711 CODEC simulations which had not been expected and may be considered in future research.

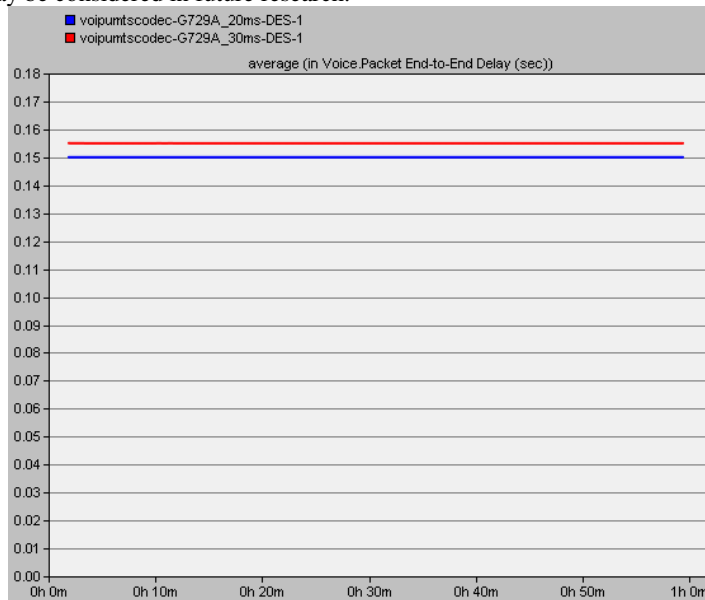

Figure 5. Delay for G.729A (20ms and 30ms frame size)

B. Voice Frames per Packets and End-to-End Delay

From the section, simulation results showed that voice calls with 20 ms frame sizes achieved better end-to-end delay results than voice calls with 30 ms frame sizes and much better results than for the other frame sizes. In this section voice calls with a 20 ms frame size will be used to investigate the relationship between end-to-end delay and voice call frames per packet.

Figure 6 shows the results for GSM-FR. Six simulations have been done using the hybrid network. The GSM-FR CODEC with a 20 ms frame size has been configured and used with a varied number of

voice call frames in each VoIP packet. As shown in Figure 6, increasing the number of voice call frames per VoIP packet will increase the end-to-end delay. The 20 ms frame size still performs better than other length frame sizes with about 150 ms end-to-end delay.

Similar results were found for the G.729A CODEC. Figure 7 shows the results collected from the group of simulations using G.729A with a 20 ms frame size.

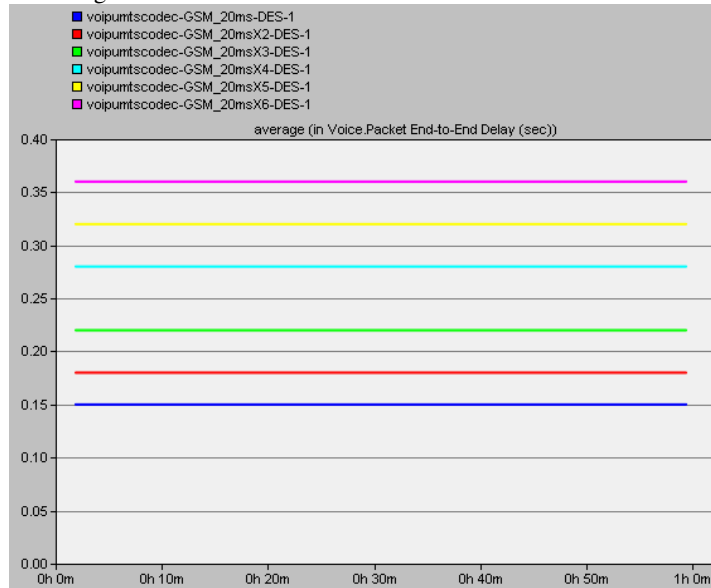

Figure 6. Delay for GSM-FR (multiple 20ms frame size)

From Figure 6 and Figure 7, the results found for the GSM-FR and G.729A CODECs identified that one voice call frame per packet will result in a lower end-to-end delay. Overall the results showed that as more voice call frames are added to each VoIP packet the end-to-end delay will increase.

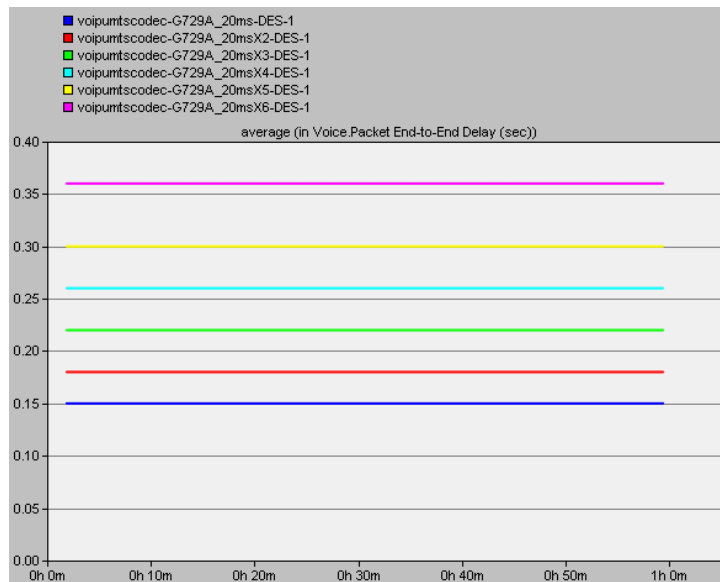

Figure 7. Delay for G.729A (multiple 20ms frame size)

V. CONCLUSION

In this research, voice call simulations were conducted using the one hybrid UMTS network to evaluate the performance of VoIP services with different CODECs. The VoIP packet end-to-end delays were examined for each configuration and compared to evaluate the VoIP call performance. The simulation results showed that there is a correlation between the end-to-end delay, the CODEC used and the number of voice frames in each VoIP packet. The G.711 CODEC was found to be unsuitable for VoIP over a hybrid UMTS network. For the GSM-FR and G.729A CODECs the best results were achieved for a 20 ms voice frame size and one voice frame for each VoIP packet. Overall, the simulations showed that for a hybrid UMTS network the selection of CODEC, the voice frame size and how the voice traffic is packaged into VoIP packets will affect the overall end-to-end delay.

VI. FUTURE WORK

In this research, the G.711 CODEC was found to perform very differently to GSM-FR and G.729A CODECs. To highlight this result, Figure 8 shows the voice traffic when a 30 ms frame size was used and Figure 9 represents the voice traffic when a 20 ms frame size was used.

Simulations using the G.711 CODEC with 4ms and 10ms frame sizes result in similar voice traffic with packet-loss rates about 50% as shown in Figure 8.

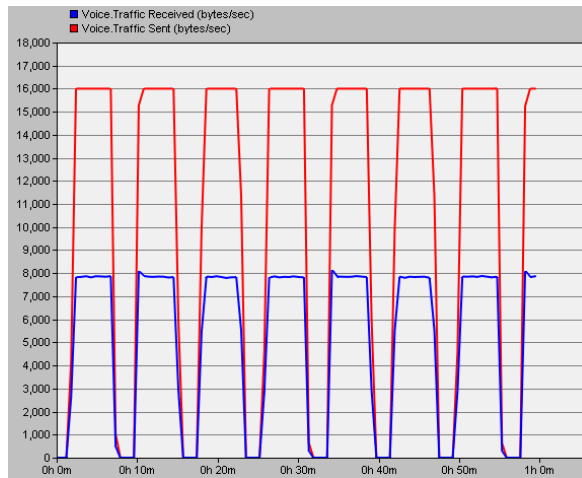

Figure 8. G.711 30ms frame size results

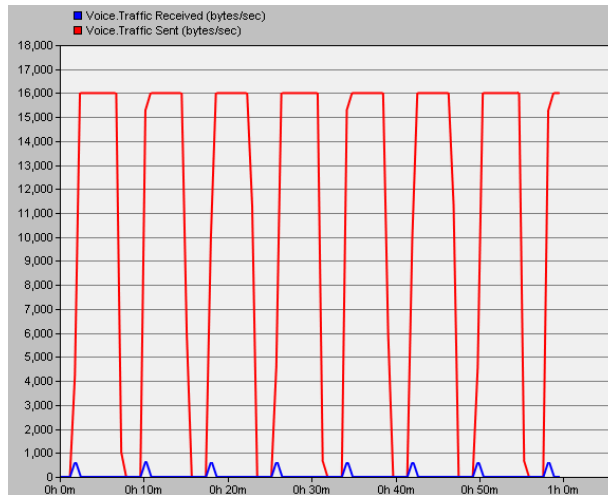

Figure 9. G.711 20 ms frame size results

For the G.711 CODEC with a 20 ms frame size varying the number of voice frames per VoIP packet did not affect the increased packet loss rate as shown in Figure 9.

REFERENCES

- [1] T. Wallingford, "Switching to VoIP", Publisher: O'Reilly, ISBN: 0-596-00868-6, Pub Date: June 2005
- [2] T. Kwok, "Residential broadband Internet services and applications requirements" Communications Magazine, IEEE Volume 35, Issue 6, June 1997 Page(s):76 - 83
- [3] R. Dominach "Quality of service for real-time IP applications", TMCnet. March 2004
- [4] The International Engineering Consortium, "UMTS Protocols and Protocol Testing", 2006
- [5] A. Samukic, "UMTS Universal Mobile Telecommunications System Development of Standards for the Third Generation", 1998
- [6] ITU-T P.830, "Subjective performance assessment of telephone-band and wideband digital codecs," 1996.
- [7] H. Schulzrinne "RTP: A Transport Protocol for Real-Time Applications" (RFC3550), 2003
- [8] IETF Network Working Group "SIP: Session Initiation Protocol" (rfc 3261), June 2002
- [9] T. Wallingford, "Switching to VoIP", Publisher: O'Reilly, Pub Date: June 2005, ISBN: 0-596-00868-6
- [10] K. Milutin, D. Damir, "IP telephony network saving capacity due to substitution of PSTN by IP network" Software in Telecommunications and Computer Networks, 2006. SoftCOM 2006. International Conference on Sept. 29 2006-Oct. 1 2006 Page(s):336 - 341
- [11] J. Janssen et al., "Assessing Voice Quality in Packet-Based Telephony," IEEE Internet Computing, vol. 6, no. 3, 2002, pp. 48-57.
- [12] F. Li "Quality and Reliability of Telephone Calls on the Internet Pre-study Report", 2001
- [13] 3GPP, Network Architecture, TS 23.002, March 2000
- [14] OPNET Modeler Radio, <http://www.opnet.com>
- [15] 20053GPP TR 25.853, Delay Budget within the Access Stratum
- [16] G. Rittenhouse and H. Zheng, "Providing VoIP Service in UMTS-HSDPA with Frame Aggregation," Proc. ICASSP,