

CRIMINOLOGY

TRAITS AND STATES: INTEGRATING PERSONALITY AND AFFECT INTO A MODEL OF CRIMINAL DECISION MAKING*

JEAN-LOUIS VAN GELDER

Netherlands Institute for the Study of Crime and Law
Enforcement (NCSR)

REINOUT E. DE VRIES

Faculty of Psychology and Education
VU University

KEYWORDS: personality, crime, affect, rational choice, self-control, dual-process models

We propose and test a model of criminal decision making that integrates the individual differences perspective with research and theorizing on proximal factors. The individual differences perspective is operationalized using the recent HEXACO personality structure. This structure incorporates the main personality traits, but it carries the advantage of also incorporating Self-Control within its personality sphere, and an additional trait termed Honesty-Humility. Furthermore, the model offers a new perspective on proximal predictors, “states,” of criminal decisions by adding affect (i.e., feelings) to the rational choice–crime equation. The proposed model is tested using scenario data from a representative sample of the Dutch population in terms of gender, age, education level, and province (N = 495). As predicted by the model, personality was both directly and indirectly related to criminal decision making. Specifically, the traits Emotionality, Self-Control, and Honesty-Humility were mediated by both affect and rational choice variables. Conscientiousness operated only indirectly on criminal decision making via rational choice. Together, the findings support a trait-state model of criminal decision making.

Additional supporting information can be found in the listing for this article in the Wiley Online Library at <http://onlinelibrary.wiley.com/doi/10.1111/crim.2012.50.issue-3/issuetoc>.

* Direct correspondence to Jean-Louis van Gelder, Netherlands Institute for the Study of Crime and Law Enforcement (NCSR), De Boelelaan 1077a, 1081 HV Amsterdam, the Netherlands (e-mail: jlvangelder@nscr.nl).

Extant literature on personality and crime reveals consistent correlations between the two (e.g., Agnew et al., 2002; Caspi et al., 1994; Eysenck, 1977, 1996; Jones, Miller, and Lynam, 2012; Miller and Lynam, 2001). There is also ample evidence that the perceived costs and benefits of crime, as suggested by rational choice and deterrence theorists, influence decisions to offend (e.g., Becker, 1968; Cornish and Clarke, 1986; Nagin and Pogarsky, 2001; Paternoster and Pogarsky, 2009). Both lines of thought have a restricted focus: one is confined to individual characteristics, whereas the other tends to limit itself to proximal variables that pertain directly to the crime situation. That is, although personality trait research can identify individual differences in predispositions to offend, it does little to explain what proximal variables may influence offending behavior. Conversely, deterrence and rational choice-based theories can help detect factors that alter the balance in cost-benefit analyses but generally do not examine individual differences in criminal propensity.

However, as Nagin and Paternoster (1993) noted, a belief that variation in offending is reflective of differences in criminal propensity between individuals does not preclude the possibility that would-be offenders are also sensitive to the attractions and deterrents of crime. Therefore, instead of being distinctively separate, these perspectives complement each other and the joint consideration of both perspectives can significantly enhance our understanding of criminal decision making. In the words of Miller and Lynam (2001: 781), in order to truly understand relations between personality and crime, the mechanisms underlying them must be identified, which requires an examination of the intervening or mediating processes that connect the distal and the proximal levels. Developing and testing an integrative model that does so is the goal of the present study.

Beyond integrating these perspectives in a comprehensive model of criminal decision making, we also extend them separately. We contribute to the individual differences perspective by using a recent and more encompassing structure of personality, the HEXACO model, than models that have been used in crime research thus far. We extend proximal approaches by adding feelings, or affect, to the rational choice-crime equation drawing from dual-process models of information processing.

To denote stable individual dispositions related to offending, we use the term "traits." Proximal factors, which operate in the moment of decision making, are referred to as "states." Below, we first deal with the trait component of the model followed by a discussion of the state component. Subsequently, we discuss their integration and the hypotheses before presenting the results of the study.

TRAITS: PERSONALITY AND CRIME

Arguably the most important individual-level correlate of delinquent behavior is self-control. An abundance of research has shown that people with difficulty controlling their impulses and considering the broader consequences of their actions are more prone to offend than those who do not (Pratt and Cullen, 2000). Although not rooted in personality psychology, the self-control concept essentially implies a personality trait as it refers to stable individual differences in the propensity to act, think, and feel in certain ways. In the words of Gottfredson and Hirschi (1990: 87), "individual differences in the tendency to commit criminal acts . . . remain reasonably stable with change in the social location of individuals and change in their knowledge of the operation of sanction systems." Self-control is therefore "well within the meaning of 'personality trait'" (Gottfredson and Hirschi, 1990: 109).

The success of the self-control concept in explaining crime and delinquent behavior is likely to have overshadowed findings from research drawing from psychological models of personality, which has established consistent relations between personality traits other than self-control and delinquent behavior (e.g., Caspi et al., 1994; Eysenck, 1977, 1996; Miller and Lynam, 2001; Moffitt et al., 2000; Tellegen, 1985). Indeed, as Caspi et al. (1994) suggested, crime-proneness is not likely to be defined only by self-control but instead by multiple psychological components.

MODELS OF PERSONALITY

Although various multidimensional models of personality have been proposed over the years, there has been increasing agreement among researchers that a handful of main dimensions, or traits, together cover the human personality. The so-called Big Five consensus distinguishes the following traits: Extraversion, Conscientiousness, Openness to Experience, Agreeableness, and (Emotional Stability versus) Neuroticism (e.g., Costa and McCrae, 1990, 1992; Goldberg, 1990; McCrae and Costa, 1990). The Big Five traits are also represented in, and referred to as, the five-factor model (FFM) (Costa and McCrae, 1992). Each of the five main traits is, in turn, made up of lower level factors or "facets." For example, Conscientiousness, which refers to the ability to exert self-discipline and control impulses, and the tendency to think carefully before acting, is composed of facets such as competence, achievement striving, self-discipline, and deliberation (Costa and McCrae, 1998). Besides Conscientiousness, the traits Agreeableness, which regards individuals' interpersonal relationships and their tendency to be trusting, straightforward, and empathic, and Neuroticism, which refers to people's emotional adjustment and stability, have emerged as consistent

correlates of antisocial behavior in crime research (Jones, Miller, and Lynam, 2012; Miller and Lynam, 2001).

Together, the Big Five/FFM personality traits and their constitutive facets were thought to embody the overarching structure behind all personality traits. However, recent reanalyses of the same data that have led to the development of the Big Five suggest that there is a sixth main dimension of personality (Ashton and Lee, 2008; Ashton et al., 2004). The new structure, the HEXACO model, that emerged from these analyses builds on, and is in many ways similar to, the Big Five and FFM models, but it extends and refines them in ways that may be particularly relevant for criminological research (for an overview of similarities and differences, see Ashton et al., 2004).

Three of the six HEXACO dimensions, Extraversion, Conscientiousness, and Openness to Experience, are identical to their equally named Big Five/FFM counterparts. Two other HEXACO dimensions, Agreeableness and Emotionality, are modified versions of Big Five/FFM Agreeableness and Neuroticism. That is, apart from the fearfulness and depression facets, FFM Neuroticism contains a hostility/anger facet, which, in the HEXACO model, has shifted to Agreeableness. At the same time, the sentimentality component of Big Five Agreeableness has shifted to HEXACO Emotionality.

These shifts may explain the paradoxical finding that both high and low Big Five/FFM Neuroticism have been found to be correlated with crime (see Miller and Lynam, 2001). The paradox is resolved by the described shift of facets between the dimensions: When reframed in terms of the HEXACO model, both low Agreeableness (i.e., *high* Big Five/FFM Neuroticism), through its association with anger and hostility, and low Emotionality (i.e., *low* Big Five/FFM Neuroticism), through its association with lack of fearfulness and lack of empathy, are personality traits that may predispose individuals to different kinds of criminal offenses.

The most significant departure of the HEXACO model from its five-dimensional predecessors, however, and the most relevant one for crime research, is the addition of a sixth dimension of personality, Honesty-Humility (Ashton et al., 2004). This dimension refers to individual differences in the tendency to be interpersonally genuine, to avoid fraud and corruption, to be uninterested in status and wealth, to be modest and unassuming, and the reluctance to take advantage of others to satisfy one's own needs (Lee and Ashton, 2004). Individuals scoring low on Honesty-Humility tend to feel a strong sense of self-importance, are motivated by material gain, feel tempted to "bend" laws for personal profit, and flatter others when this is instrumental in the pursuit of their own goals. We argue that these individuals are more likely to violate rules both because they

have lower moral standards and because they care less about the well-being of others who may be affected by their behavior.

Recent empirical research has shown that by virtue of the inclusion of Honesty-Humility in the HEXACO structure, it outperforms both the FFM and the Big Five model with respect to several behavioral criteria related to offending such as psychopathy, Machiavellianism, egoism, immorality, pretentiousness, unethical decision making, and employee integrity (Ashton and Lee, 2008; De Vries, Ashton, and Lee, 2009; De Vries and Van Kampen, 2010; Lee and Ashton, 2005).

Finally, the HEXACO model yields another important advantage over other models of personality, which is its ability to integrate the psychological personality perspective with the criminological self-control paradigm. Within the HEXACO personality space, self-control can be viewed and operationalized as an interstitial trait based on a set of facets pertaining to several of the main dimensions of the model. Essentially, self-control as defined by Gottfredson and Hirschi (1990) is a broad dimension of individual disposition that consists of more specific elements such as self-centeredness, risk-seeking behavior, and impulsivity. These elements are also represented as facets in the HEXACO model, and therefore, a self-control scale can be derived from the model (see the Method section for further explication).

In other words, the HEXACO model offers a broad conceptualization of personality that encompasses and extends five-factor models in important ways, but also incorporates self-control. Thus, the model is able to locate the latter within the broader personality structure of individuals and integrate the psychological personality perspective with the most important individual disposition paradigm in criminology. In sum, we believe the HEXACO model has much to contribute to crime research and therefore use it as the operationalization of the trait component of the trait-state model of criminal decision making. Next we discuss the other constitutive component of the model, "states."

STATES: RATIONAL CHOICE AND STATE AFFECT

Rational choice theories posit a reasoning actor who balances costs against benefits to arrive at a decision. The assumption is that, when faced with several possible courses of action, people will gravitate toward the option they believe is likely to have the best overall outcome (Elster, 1989). According to rational choice theory's punishment corollary, deterrence theory, people will offend when they perceive the potential benefits to exceed the anticipated costs and will refrain from doing so when the costs outweigh the gains. Perceived costs such as the severity and certainty of punishment are therefore central inputs to the criminal choice calculus. According to

this perspective, a criminal act essentially implies taking a risk (i.e., making a decision with an uncertain outcome and a possibility of loss).

Although rational choice and deterrence models tend to be largely cognitive in nature (i.e., based on thinking), various authors have noted that feelings may also play an important role in decisions to commit a crime (e.g., Agnew, 1992; Athens, 2005; Katz, 1988; Wright and Decker, 1994, 1997). We argue that adding feelings to the rational choice–crime equation is likely to generate a more encompassing picture of the criminal decision-making process, compared with focusing only on cognition or feelings. One important reason for differentiating between cognitive and affective (i.e., feeling-based) reactions to risk and criminal decision making is the different operative logic underlying each. That is, cognitive appraisals and emotional reactions to risk have different determinants. For example, emotions respond differently to probabilities and outcomes, the two central input variables of rational choice and deterrence models, than cognitive evaluations of riskiness (see Loewenstein et al., 2001). As Frijda (1988: 355) noted, “emotions know no probabilities. They do not weigh likelihoods. What they know, they know for sure.” In short, because feelings have determinants that differ from cognitions about a risk, and can therefore cue different behavioral responses, we believe them to be an important addition to models of criminal decision making.

In this article, we focus on feelings of fear and insecurity, which we denote as “negative state affect,” evoked by decision-making situations and examine these feelings in conjunction with perceived severity and certainty of punishment to examine how both are related to criminal decisions. We do so by drawing from so-called *dual-process* and *dual-system models of information processing* (e.g., Chaiken and Trope, 1999; Epstein, 1994; Metcalfe and Mischel, 1999; Smith and Neumann, 2005; Strack and Deutsch, 2004; Van Gelder, 2012; Van Gelder et al., 2009). The central assumption of these models is that there are two separate modes or systems of mental processing that operate simultaneously when we engage in acts such as making judgments, considering risky prospects, valuing stimuli, and processing information. One mode, which we will refer to as the cool mode, is largely cognitive in nature and based on more deliberate and analytical considerations. The cool mode, therefore, operates roughly according to the precepts of rational choice theory (Van Gelder, 2012). The other mode, the hot mode, relies more on intuitive, automatic, and affect-based processing (e.g., Metcalfe and Mischel, 1999; Van Gelder, 2012; Van Gelder et al., 2009) and has a proper operative logic.¹

1. Note that not all dual-process models that have been proposed characterize the dividing line between the two modes as one of cognition versus affect. Even though the models share several characteristics, they differ on other, subtler, points.

When it comes to evaluating risky prospects, dual-process notions assume the two modes of processing to respond to different characteristics of a situation (Kahneman, 2003; Slovic et al., 2002; Van Gelder et al., 2009). The cool, thinking-based, mode is sensitive to risk considerations such as probabilities. The hot mode is relatively unresponsive to probabilities of decision outcomes, but instead it responds to properties of a situation that play only a minor role in cognitive evaluations, such as the vividness with which the outcomes can be imagined and their temporal or spatial proximity (Loewenstein et al., 2001; Slovic et al., 2002). Importantly, the hot mode is tied to the here and now, while the cool mode can also consider the future. For example, emotions such as fear or anger alert us of imminent threat and ready us to respond immediately to a situation, whereas cognitions take delayed consequences into account.

The potential divergence in behavioral responses cued by the hot mode and the cool mode explains why we can think about something one way (e.g., “I really shouldn’t do it because it is too risky”) but feel about it differently (e.g., “I crave it, so I’ll just take my chances”). Precisely because the way individuals think about a situation may differ from how they feel about it, as implied by dual-process models, it makes sense to study cognition and affect in conjunction as proximal predictors of delinquent behavior.

ANTICIPATED VERSUS IMMEDIATE AFFECT

Even though emotions have occasionally been included in models of criminal decision making, our approach differs from those taken in previous studies. When addressing affect, previous research has incorporated emotions such as anticipated shame and expected guilt (e.g., Grasmick and Bursik, 1990; Nagin and Paternoster, 1993; Paternoster and Simpson, 1996; Piquero and Tibbetts, 1996). These *anticipated* emotions enter the decision calculus as costs that can be taken into account as such by the decision maker (Loewenstein et al., 2001). However, the emotions themselves are expected to be felt only once outcomes have materialized, instead of at the time of decision. I am, for example, unlikely to feel guilty about or ashamed of something I have not done (yet). In other words, this type of emotion essentially regards predictions about future emotional states rather than emotions experienced at the moment of deciding on a course of action. In terms of the dual-process approach, the consideration of potential future regret, guilt, and shame, like estimates of probability and severity, belongs to the domain of the cool, cognitive, mode as they, at the time of decision, primarily regard *thoughts about feelings* instead of feelings themselves. For example, note the fundamental difference between the following two considerations that may be relevant when facing a criminal choice: “If I do this now, I will regret it later” versus “The thought of apprehension scares

me.” While the regret is expected to materialize after a certain course of action has been chosen, the fear of apprehension operates in the moment of decision making. Recall in this respect the difference between the hot mode that operates in the here-and-now and the cool mode that can also consider factors that do not pertain to the immediate present.

The immediate visceral reactions to risks and uncertain situations, such as fear, so-called *anticipatory* emotions, *are* experienced at the time of decision (Loewenstein et al., 2001). Therefore, these emotions imply processing by the affect-based, hot mode. Although immediate affect includes a wide range of feelings, such as anger and greed, but also positive affect such as thrill, excitement, relief, and satisfaction, we limit ourselves to feelings of fear and anxiety triggered by a decision situation in this article. We think this is a particularly productive point of departure with respect to criminal decision making as these feelings form the affective counterpart of cognitions about risk and deterrence (i.e., the perceived probability and severity punishment).

INTEGRATING TRAITS AND STATES

The general assumption underlying the proposed model is that taking into account both individual traits and proximal, state, variables offers a more complete picture of criminal decision making than looking at either component in isolation. At the basis of this assumption is the hypothesis that different aspects of personality are differentially related to the proximal variables under study. We therefore examine the HEXACO model of personality as a predictor of criminal choice while simultaneously drawing from dual-process models by distinguishing perceived risk of sanction from the state affect evoked by a situation. In this study, we focus on the role of one specific type of state affect, that is, the negative feelings of fear and worry evoked by a situation, which is henceforth referred to as “negative state affect.” We hypothesize that negative state affect and perceived risk mediate the relationship between personality and criminal choice. The proposed trait-state model is presented in figure 1.

In line with this reasoning, we believe HEXACO Honesty-Humility, Emotionality, Conscientiousness, Agreeableness, and Self-Control to be important predictors of criminal choice. We hypothesize Emotionality to operate both through negative state affect, that is, feelings of worry and fear, and through state cognition, that is, perceived risk, in preventing or provoking criminal decisions. That is, people low in Emotionality tend to be less fearful in nature, are less anxious about possible consequences of their actions, and lack feelings of dependence on, and sentimentality toward, other people. Lack of fearfulness has been shown to be the most important predictor of thrill and adventure seeking (De Vries, De Vries, and Feij,

Figure 1. Hypothesized Relations among HEXACO Agreeableness, Emotionality, Honesty-Humility, Self-Control, Conscientiousness, Negative State Affect, Perceived Risk, and Criminal Choice

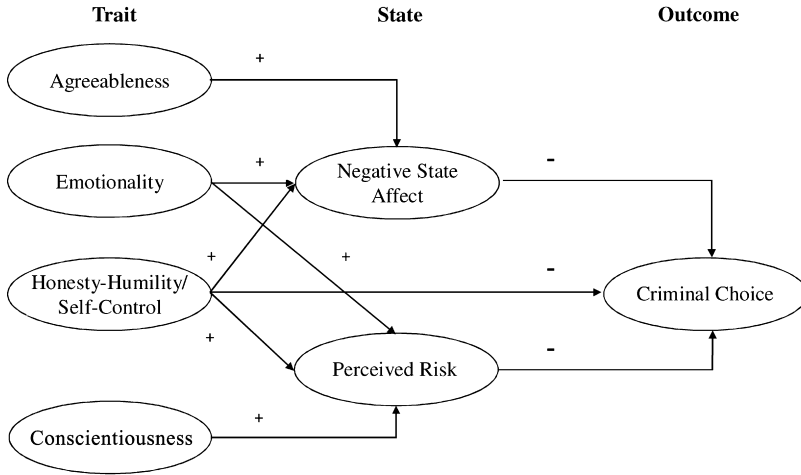

2009), and it is therefore expected to result in lower levels of negative state affect in situations that carry risk. At the same time, a lack of anxiety about the possible consequences of one’s actions is also likely to result in lower levels of anticipation of the severity and likelihood of the consequences of criminal actions. That is, to reverse the argument, people high in Emotionality are probably more likely than people low in Emotionality to be able to imagine what may happen to themselves (anticipated punishment) and others (anticipated empathy) in case they would opt for the criminal option, and consequently, they are less inclined to choose it.

In a similar vein, people low on Agreeableness, who are more likely to experience anger and hostility when feeling “wronged,” are more likely to have a lower threshold for offending. Their impatience and quick loss of temper may crowd out feelings of fear and insecurity that may be evoked by the decision situation, which consequently lose their deterrent potential. But in contrast to Emotionality, we expect their response to potential crime situations to be mediated only by negative state affect and not by cognitions that may temper their impulsive responses. That is, because Agreeableness has been found to be only weakly (negatively) related to sensation-seeking and risk-taking behaviors (De Vries, De Vries, and Feij, 2009), we believe that higher or lower levels of Agreeableness do not make much of a difference with respect to the levels of anticipated consequences of one’s actions.

In contrast to Agreeableness, we believe Conscientiousness to operate mainly through perceived risk. People high in Conscientiousness are more inclined to assess carefully the consequences of their actions, whereas people low on Conscientiousness are less likely to perceive the risks involved and to evaluate the long-term implications of their actions and are thus more likely to commit criminal acts. That is, although people low in Conscientiousness are more impulsive and disinhibited when it comes to risky situations (see De Vries, De Vries, and Feij, 2009) and are consequently less likely to think about the risks associated with theft, embezzlement, fraud, or other criminal activities, people high on Conscientiousness are more prudent and more likely to contemplate carefully the long-term risks associated with these activities, and to consider more extensively the potentially negative consequences (e.g., fines, social disapproval, jail, and ostracism) of their actions. Note that the impulsivity implicated in low levels of Conscientiousness does not signify that people low in Conscientiousness are often in a “hot” mode. Impulsivity may be unrelated to feelings of fear, worry, or anger, although the reverse may be true (i.e., that lack of control over these emotions may cause someone to act impulsively).

Honesty-Humility is expected to operate both directly on criminal decisions, through automatic (learned) behaviors, and indirectly by impacting on both negative state affect and perceived risk. The direct effect of Honesty-Humility on criminal choices may come about because people low on Honesty-Humility are more likely to have acquired, from an early age on, the ability to detect automatically criminal opportunities, such as opportunities for theft, and to act on them once they arise. As a consequence, these behaviors may have become habitual in nature. Honesty-Humility is also expected to be associated with negative state affect. That is, people high in Honesty-Humility are more prone to experience negative emotions associated with various kinds of criminal activities, as a consequence of which they are less likely to commit them. At the same time, they are more likely to think about the possible negative consequences of criminal decisions. In contrast to Conscientiousness, which regards thinking through the possible consequences for oneself, people high in Honesty-Humility are also more likely to consider the consequences of criminal activities for other people and society as a whole. That is, the contemplated anticipated unfairness and negative implications, not so much for themselves, but mainly for others and for society at large, are more likely to play a more important role for people high in Honesty-Humility than they do for people low in Honesty-Humility.

Finally, in accordance with the conceptualization of Self-Control as an interstitial trait that is aligned with Conscientiousness, Honesty-Humility, and Emotionality, we assume Self-Control to operate both directly and indirectly, through negative state affect and perceived risk on criminal choice. That is, people low on Self-Control are more likely 1) to engage

in impulsive, risky behaviors associated with crime and, as a consequence, are more prone to habitually commit criminal acts; 2) to have lower levels of fearfulness, which is characteristic of people who exhibit less negative state affect; and 3) to have lower levels of prudence and “fair play” attitudes, which are associated with lower levels of mental activity used for planning and thinking about the potential costs of criminal decision and hence perceived risk. The hypothesized relations, which were described earlier, are shown in figure 1 and tested using different scenarios featuring criminal dilemmas and structural equation modeling (SEM).

METHOD

RESPONDENTS AND PROCEDURE

Data were gathered through a large-scale internet panel, set up strictly for research purposes.² The panel consists of approximately 20,000 members and is representative of the Dutch population with respect to gender, age, education level, and province of residence. To ensure representativeness, data from Statistics Netherlands are used. Panel members are invited to complete online surveys various times a year.

Data were gathered over two different waves. In the first wave, a randomly selected subsample of 2,000 Dutch adult (≥ 18 years) citizens was drawn from the panel and approached through e-mail. In this wave, which was conducted in April 2008, HEXACO personality data were gathered. In the second wave, which was conducted 1.5 years later, in October 2009, data regarding the state and criminal choice variables were collected.

In the first wave, 68.9 percent of the sample (1,377 respondents; 50.2 percent women) responded to the call. The second wave targeted the respondents of the first wave of which 52 percent responded to the call. This sample therefore consisted of 716 Dutch citizens (52.8 percent women) ranging from 19 to 88 years with a mean age of 50.8 years (standard deviation [SD] = 14.4 years) who had also participated in the first wave. We decided to restrict the upper age limit for inclusion to 60 years as we felt that people beyond this age would be beyond the life stage of those

-
2. The panel is certified by the International Organization for Standardization (ISO), which is a nongovernmental organization that sets worldwide industrial and commercial standards. ISO certification refers to a quality mark that testifies to the adherence to a set of strict standards and norms for research panels with respect to the design and execution of research. Panel members are recruited through send-to-a-friend campaigns among existing panel members, newsletters, and lists of addresses from third parties taking part in surveys. The panel also grows autonomously by word-of-mouth. In exchange for participation, respondents receive credits that can be saved and, at a later moment, be exchanged for goods.

whose criminal decision making is of most interest to criminologists.³ By restricting ourselves to adult participants up until 60 years old, the second wave consisted of a final sample of 495 respondents (57.4 percent female) in the age range of 19–60 years who participated in both waves. The mean age of the respondents was 43.8 years ($SD = 10.6$ years), and their educational levels ranged from primary education (2.2 percent), low-level secondary education (17.8 percent), high-level secondary education (18.8 percent), low-level tertiary education (6.1 percent), medium-level tertiary education (25.9 percent), high-level tertiary education (17.6 percent), to university-level education (11.7 percent).

To check for sample loss, we compared the original targeted sample with the final sample on several variables. The results indicate differences between both samples only with respect to gender; women were significantly overrepresented in our sample (57.4 percent vs. 50.2 percent in the original sample, $p < .001$). No differences in education were found between the two samples. In terms of province, the breakdown also closely follows that of the original sample. Finally, no differences were found on the scores on the HEXACO personality traits between the first wave and the final sample.

SCENARIOS

To test the trait-state model, a scenario design comprising four different scenarios was developed. The scenarios were presented as “dilemmas” in a short introduction to the study. Each of the four dilemmas featured a description (8–12 lines) of a criminal choice situation. Respondents were asked to imagine that they were in the described situation and to answer several questions pertaining to it. To optimize ecological validity, an attempt was made to design scenarios that were personally relevant to the respondents and that described relatively common, everyday criminal choice situations (e.g., illegal downloading and purchase of stolen goods). To optimize external validity, multiple scenarios were used. One scenario, “A new computer,” reads as follows (for the other scenarios, see S.1 in the online supporting information⁴):

-
3. Even though the choice of 60 years is somewhat arbitrary, and an age limit of around 40 years may seem more appropriate given the decline in offending over the life course, we found no differences in correlations between the independent and dependent variables for these age groups. Furthermore, we deliberately drafted scenarios that were relevant to both younger and older adults (see the discussion in the next section).
 4. Additional supporting information can be found in the listing for this article in the Wiley Online Library at <http://onlinelibrary.wiley.com/doi/10.1111/crim.2012.50.issue-3/issuetoc>.

Imagine the Following

You need a new computer. One of your colleagues mentioned that he bought his computer through an acquaintance for a very attractive price, about 40 percent below the retail value. Your colleague told you that the acquaintance has more new computers for sale that meet your criteria and that come in the original packaging. Your colleague also mentioned that the computers probably “fell off a truck” somewhere, so there is no receipt. However, you are being assured, in case problems arise with your computer within two years after purchase, it will be replaced by a new one without cost so that you do not need to worry about the guarantee.

Buying, possessing, or selling goods of which one knows or could know that these have been obtained through a criminal act is illegal in the Netherlands, and the fine for complicity can be high.

INDEPENDENT VARIABLES

Each scenario was followed by items measuring anticipated punishment probability (henceforth “probability”), anticipated punishment severity (henceforth “severity”), negative state affect, and the dependent variable criminal choice. For each construct, we aggregated the responses on all scenarios to arrive at more reliable and valid measures. We used all scenarios to reduce as much as possible the influence of individual experiences, feelings, or cognitions vis-à-vis particular scenarios on the responses provided. Aggregating the responses on all scenarios reduces error variance and ensures a more valid estimate of the typical response to a potentially criminal situation than responses to a single scenario.

Perceived Risk

Perceived Risk is a composite measure of punishment probability times punishment severity. Two items per scenario, using seven-point scales, measured punishment probability (e.g., “How likely is it that you will be caught when you buy the potentially stolen computer?” [*very unlikely–very likely*]) and “How big do you think is the chance that you will be found out if you buy the computer of your colleague’s acquaintance?” [*very small–very large*]). Rather than experimentally manipulating probability, respondents were asked to give their own estimate to avoid the artificiality of furnishing probabilities that respondents could find unrealistic (see Nagin and Pogarsky, 2001). The same approach was applied to punishment severity, which was also measured by two items using seven-point scales (e.g., “How serious do you consider the possible consequences of being caught to be?” [*not at all serious–very serious*]) and “How annoying do you find the potential negative consequences of buying the computer through your

colleague's acquaintance?" [*not at all annoying–very annoying*]). A perceived (sanction) risk measure that reflected both probability and severity (*Probability* \times *Severity*) was constructed by multiplying the mean scores of the probability items with the mean scores of the severity items (see Nagin and Paternoster, 1993).⁵ The composite perceived risk measure for the four different scenarios consisted of eight items (two per scenario) each based on the Probability \times Severity multiplication (multiplying the scores of the first with the second item, and the third with the fourth item). The scale, for which scores could range from 1 to 49, had an alpha reliability of .86.

Negative State Affect

Negative State Affect was measured with five items per scenario using seven-point scales (*strongly disagree–strongly agree*). The items were preceded by the sentence: "Imagine you decide to commit/do [the offense]": "Would this situation make you feel insecure?" "Do you find the situation frightening?" "Would you be worried?" "Would you be nervous?" And "Does the situation evoke negative feelings in general?" (*not at all–very much*). A negative state affect scale was computed based on the averaged responses on the negative affect items of the four scenarios, which resulted in a score range of 1–7. The scale had an alpha reliability of .96.

HEXACO Personality Inventory

Personality was measured using the 200-item version of the HEXACO Personality Inventory Revised (Ashton and Lee, 2008; De Vries, Ashton, and Lee, 2009).⁶ Each of the six HEXACO dimensions is measured by 32 items, eight per facet, on five-point (*strongly disagree–strongly agree*) scales. One interstitial facet represents Altruism. In previous studies, principal component analysis (PCA) on the 24 facets representing the six dimensions revealed six main factors with eigenvalue > 1 , a clear break of eigenvalues after the sixth factor, and highest loading of the facets on their intended factors (De Vries, Ashton, and Lee, 2009; Lee and Ashton, 2004).⁷ The

-
5. As an alternative measure of perceived risk, we also computed a variable based on the mean scores of the probability and the severity items and correlated this sum measure and the original multiplicative measure with the other variables. The patterns are nearly identical for both measures with the multiplicative measure doing slightly better. We therefore retained the multiplicative measure for the analyses.
 6. The 100-item version of the HEXACO Personality Inventory can be freely obtained (for research purposes) from www.hexaco.org. For information on the 200-item version, please contact the authors.
 7. Because five items of the Fairness facet of the Honesty-Humility dimension were tautological in nature, for the purposes of the present research (i.e., showed

HEXACO-PI-R factor scales are computed on the basis of the averaged item scores and hence have a range of 1–5. All alpha reliabilities of the factor scales exceeded .84, and none of the absolute correlations between the factor scales exceeded .28.

HEXACO Self-Control

According to Gottfredson and Hirschi (1990), self-control is a broad individual disposition that contains impulsivity, lack of diligence and persistence, preference for physical (as opposed to cognitive) activities, risk-seeking, self-centeredness, and low frustration tolerance. This conceptualization lies at the basis of the self-control scale developed by Grasmick et al. (1993), which is the most commonly used operationalization of the concept in crime research. In this study, we will follow this conceptualization of self-control and operationalize it as an interstitial trait in the HEXACO personality space based on various facets of different main dimensions of the HEXACO model.⁸

This is done following the approach suggested by De Vries, De Vries, and Feij (2009), which consists of three steps. First, we selected the HEXACO facets that correlated most strongly with the Grasmick et al. (1993) Self-Control scale. Second, we ran regressions using these facets with Grasmick et al. (1993) Self-Control as a dependent variable. Third, we simplified the regression to the following formula in which multiplication terms were assigned to the facets on the basis of the value of the standardized regression coefficients of each facet: $\text{HEXACO Self-Control} = (3 \times \text{Prudence} + 2 \times (\text{Fairness} + \text{Modesty} + \text{Fearfulness} + \text{Flexibility}) + (\text{Social Self-esteem} + \text{Patience} + \text{Inquisitiveness} + \text{Diligence} + \text{Altruism}))/16$. That is, HEXACO Self-Control is interstitial in the six-dimensional personality sphere consisting of the Conscientiousness facet Prudence, the Honesty-Humility facets Fairness and Modesty, the Emotionality facet Fearfulness, the Agreeableness facet Flexibility, and to a lesser extent the Extraversion facet Social Self-esteem, the Agreeableness facet Patience, the Openness to Experience facet Inquisitiveness, the Conscientiousness facet Diligence, and the interstitial facet Altruism. The final HEXACO Self-Control scale,

predictor-criterion overlap [e.g., “I would never accept a bribe, even if it were very large”]), these items were omitted from the analyses.

8. The reason for basing the analyses on the HEXACO Self-Control operationalization instead of the Grasmick et al. (1993) scale, beyond demonstrating how self-control can be incorporated within the HEXACO personality sphere, is that when tested simultaneously in a regression analysis, the HEXACO Self-Control measure turned out to be a better predictor of criminal choice ($\beta = .23, p < .01$) than the Grasmick measure ($\beta = .12, p = .03, R^2 = .10, F(1, 492) = 27.68, p < .001$).

used in this study, correlated .61 ($p < .01$) with the original Grasmick et al. (1993) Self-Control scale.

DEPENDENT VARIABLE

Criminal Choice

The dependent variable, Criminal Choice, was measured with three items. Two items inquired about the likelihood that the respondent would choose the criminal option. In one of these items, respondents were asked to give a percentage estimate of this likelihood. The other item also inquired about likelihood, but it used a seven-point scale (e.g., "How likely is it that you would decide to buy the computer of your colleague's acquaintance" [*very unlikely–very likely*]). The third item measured the degree of certainty of the criminal choice (i.e., "How certain are you about this?" [*not at all–completely*]). The seven-point likelihood item was recoded to a scale that ranged from -3 to $+3$, and a criminal choice score was computed by multiplying the recoded likelihood item with the certainty item, so that the scores could range from -21 to $+21$. Together with the percentage estimate item, this recoding resulted in a composite criminal choice measure based on eight items (two per scenario) with a reliability of .96.

RESULTS

To test the trait-state model, we first computed the bivariate correlations between the HEXACO personality dimensions, Negative State Affect and Perceived Risk, and the dependent variable Criminal Choice for the combined score of the four scenarios (table 1). Honesty-Humility, Agreeableness, Conscientiousness, and Self-Control were significantly correlated with Criminal Choice. No significant correlations between Emotionality, Openness to Experience, and Extraversion on the one hand and Criminal Choice on the other were found. Both Perceived Risk (i.e., Probability \times Severity) and Negative State Affect were strongly related to Criminal Choice.⁹ Furthermore, Honesty-Humility, Agreeableness, Emotionality and Extraversion, and HEXACO Self-Control were all significantly correlated with both Perceived Risk and Negative State Affect. Conscientiousness was related only to Perceived Risk.

Subsequently, we tested our prediction that Negative State Affect and Perceived Risk mediated the relations between personality and Criminal

9. For each scenario, there were also significant correlations ($p < .01$) among anticipated punishment probability, anticipated punishment severity, and criminal choice.

Table 1. Correlations of HEXACO-PI-R Scales, HEXACO Self-Control, Perceived Risk, Negative State Affect, and Criminal Choice

	1	2	3	4	5	6	7	8	9	10
Mean	3.80	3.14	3.35	3.05	3.44	3.21	3.42	34.06	4.66	19.66
Standard Deviation	.49	.47	.47	.44	.40	.47	.27	20.08	1.36	9.22
1. Honesty-Humility	—	—	—	—	—	—	—	—	—	—
2. Emotionality	.13**	—	—	—	—	—	—	—	—	—
3. Extraversion	-.04	-.28**	—	—	—	—	—	—	—	—
4. Agreeableness	.28**	-.15**	.12**	—	—	—	—	—	—	—
5. Conscientiousness	.08	-.03	.18**	.05	—	—	—	—	—	—
6. Openness to Experience	-.10*	-.17**	.24**	.06	.08	—	—	—	—	—
7. HEXACO Self-Control	.63**	.13**	.13**	.58**	.45**	.07	—	—	—	—
8. Perceived Risk	.26**	.21**	-.09*	.12**	.16**	-.04	.24**	—	—	—
9. Negative State Affect	.31**	.35**	-.18**	.09*	.03	-.03	.28**	.66**	—	—
10. Criminal Choice	-.29**	-.06	.03	-.17**	-.10*	-.04	-.24**	-.52**	-.58**	—

NOTE: *N* = 495.

p* < .05; *p* < .01.

Choice. This prediction was tested over two separate models using SEM in AMOS (SPSS Corporation, Chicago, IL; Arbuckle, 2007). In the first SEM, we included the main HEXACO dimensions as trait variables but not HEXACO Self-Control. In the second model, we included HEXACO Self-Control but omitted the main HEXACO dimensions. The reason for testing the predictions over separate models instead of combining them into one model is that if tested simultaneously, the overlap in facets between HEXACO Self-Control and the other HEXACO dimensions would distort the relationships between the variables in the model.

We decided to use latent variables in the SEMs to obtain better (e.g., disattenuated) estimates of the model’s path coefficients. For each latent variable, two parallel parcels were constructed that were used as manifest indicators. For the HEXACO variables, we included items of the half-length (100-item; see De Vries, Ashton, and Lee, 2009) version of the HEXACO variables into one parcel, and the remaining items into another parcel. Similarly, for the proximal variables and Criminal Choice, we included half the items from the different scenarios into one parcel and the remaining items into a second parcel.

The decision in favor of the “two parallel parcels” approach instead of using individual items as manifest variables or—in the case of the HEXACO personality scales—as personality facets was based on several reasons. First, items are known to contain unique variance and spurious cross-loadings,

which is parceled out when combining them, thus ensuring more reliable indicators of a latent construct and a better approximation of normality in continuous distributed variables. Additionally, using items in models increases their complexity manifold and raises the number of degrees of freedom relative to the sample N , leading to poorer model fit (Bentler and Chou, 1987; Hagtvét and Nasser, 2004). Second, as a result of their interstitial nature, the use of personality facets often leads to the occurrence of cross-loadings, which also results in poor model fit (Ashton et al., 2009). The procedure adopted in this study prevents cross-loadings and offers a parsimonious way of testing the effects of personality on the other variables compared with models in which all the personality dimensions are represented by the original items or facets.

To model the two-way relation between Negative State Affect and Perceived Risk, we decided to allow the errors (ζ 's) of the two proximal variables to covary. Furthermore, we also allowed the error terms of the Criminal Choice variable to covary. Given the fact that the wording of two of the original items was very similar and referred to the likelihood of making a criminal choice, it was proper to include this error covariance.

Finally, because no single measure identifies a correct model given the sample data, it is good practice to report various fit indices of structural and measurement models (e.g., Gibbs, Giever, and Higgins, 2003; Hoyle and Panter, 1995; Hu and Bentler, 1999; Schumacker and Lomax, 2004). For the comparative fit index (CFI), the goodness-of-fit index (GFI), and the Tucker–Lewis index (TLI), values close to .95 indicate a good fit (Hu and Bentler, 1999; Schumacker and Lomax, 2004). For the root-mean-square error of approximation (RMSEA), values equal to or smaller than .05 indicate a good fit (Hu and Bentler, 1999).

MODEL 1: MAIN HEXACO DIMENSIONS, NEGATIVE STATE AFFECT, PERCEIVED RISK, AND CRIMINAL CHOICE

In model 1, we included the HEXACO trait variables Honesty-Humility, Emotionality, Agreeableness, and Conscientiousness; the mediating proximal variables Negative State Affect and Perceived Risk; and the outcome variable Criminal Choice on the basis of the hypothesized relationships (see figure 1). The model, which was based on the product moment correlation matrix and maximum likelihood (ML) estimation, had an adequate fit: $\chi^2(\text{d.f.} = 63) = 128.50, p < .01$; CFI = .95, GFI = .96, TLI = .92, and RMSEA = .05. However, even though this model had a satisfactory fit, the standardized path coefficient from Agreeableness to Negative State Affect was not significant ($\gamma = .02$ and $p = .88$). We therefore decided to remove this path from the model. Note that by removing this path, Agreeableness

was completely removed from the model. The final model, containing the standardized path coefficients of the main latent and observed (i.e., manifest) variables and the errors and covariances, is shown in figure 2. The ellipses in figure 2 represent the latent variables, whereas the rectangles represent the observed variables. This final model also had an adequate fit ($\chi^2(\text{d.f.} = 43) = 100.70, p < .01$; CFI = .95, GFI = .97, TLI = .92, and RMSEA = .05) and provided the most parsimonious representation of the relations between Criminal Choice and both the trait and state variables.

As shown in table 2 (for the same model with gender and age added as control variables, see S.2 in the online supporting information), the main determinants of Criminal Choice were (in order of predictive importance) Negative State Affect, Perceived Risk, Honesty-Humility, and Emotionality. Honesty-Humility and Emotionality were both directly and indirectly, via Negative State Affect and Perceived Risk, related to Criminal Choice. That is, Honesty-Humility and Emotionality were positively related to both Negative State Affect and Perceived Risk, which in turn were negatively related to Criminal Choice. However, while Honesty-Humility had a negative direct effect on Criminal Choice, this effect was positive for Emotionality. Conscientiousness was only (positively) related to Perceived Risk.

The indirect effects from the personality traits to the outcome variable Criminal Choice were all significant (see table 2). In other words, the effects of Honesty-Humility and Emotionality operated both through Negative State Affect and Perceived Risk and directly on Criminal Choice. Conscientiousness, however, was only indirectly related to Criminal Choice as its effect operated via Perceived Risk. Note the negative indirect effect of Emotionality on Criminal Choice that is countered by a positive direct effect, which leads to a total effect that is near zero.

The (total) indirect effects do not speak to whether the effect between a trait and the outcome variable is mediated by either Negative State Affect or Perceived Risk or by both state variables. To test our mediation hypotheses (i.e., to examine whether the *specific* indirect effects between the traits Honesty-Humility and Emotionality and Criminal Choice are significant), we use the distribution of products approach (MacKinnon et al., 2002). This approach involves the conversion of the parameter estimates that comprise a mediation relation (e.g., from Honesty-Humility to Negative State Affect, and from Negative State Affect to Criminal Choice) into z scores by dividing each unstandardized parameter estimate by its standard error and multiplying the resulting two z scores ($z_\alpha z_\beta$) and by using a critical value based on the distribution of the product of random variables to determine significance. We find that both state variables are statistically significant mediators of the relation between both Honesty-Humility and Emotionality and Criminal Choice ($p < .001$).

Figure 2. Structural Paths among the Latent Variables in the Structural Equation Model Involving HEXACO Honesty-Humility, Emotionality, and Conscientiousness, Negative State Affect, Perceived Risk, and Criminal Choice

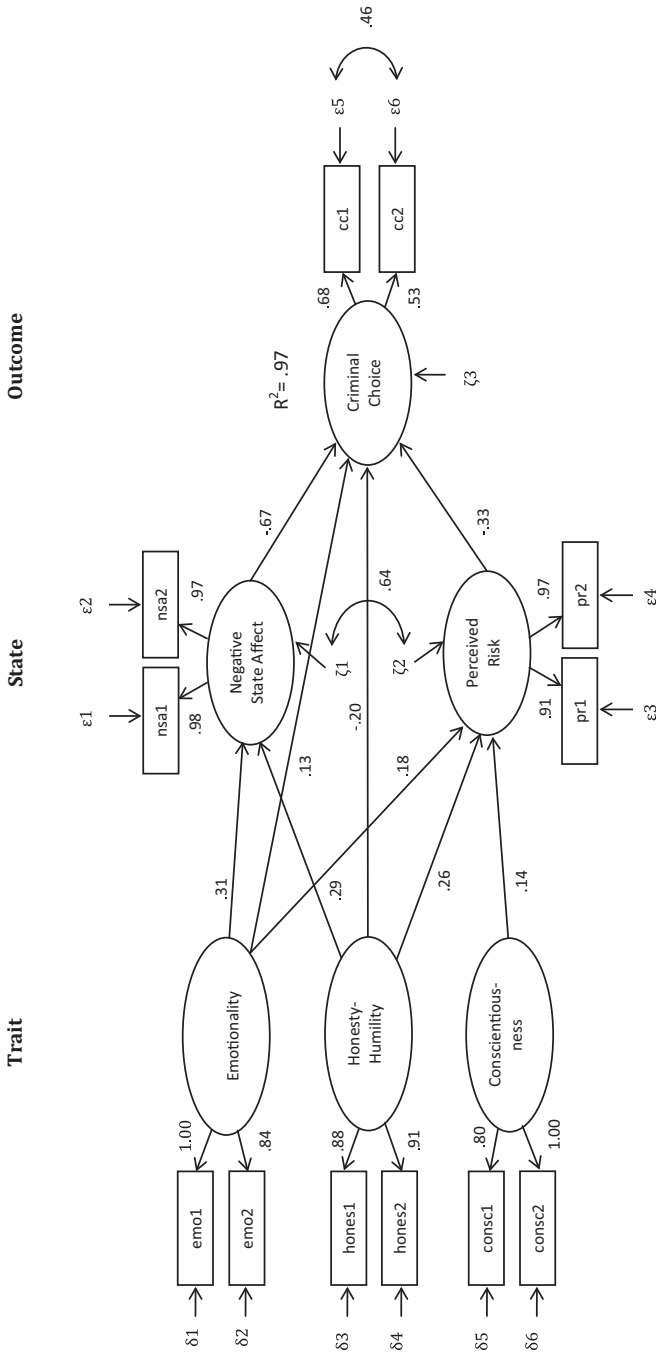

NOTES: The paths from the latent to the observed variables refer to standardized factor loadings. Double-headed arrows refer to the covariance between errors (ζ's).

Table 2. Unstandardized and standardized path coefficients and significance levels for Model in Figure 2

Estimates	Unstandardized Coefficients (S.E.)		Standardized Coefficients	<i>p</i>
Measurement Model				
Emotionality—emo1	1.51	(.05)	1.00	.00
Emotionality—emo2	1.00	—	.84	.00
Honesty-Humility—hones1	1.10	(.09)	.88	.00
Honesty-Humility—hones2	1.00	—	.91	.00
Conscientiousness—consc1	.84	(.03)	.80	.00
Conscientiousness—consc2	1.00	—	1.00	.00
Negative State Affect—nsa1	1.00	—	.98	.00
Negative State Affect—nsa2	.96	(.02)	.97	.00
Perceived Risk—pr1	1.00	—	.91	.00
Perceived Risk—pr2	1.15	(.04)	.97	.00
Criminal Choice—CC1	1.00	—	.68	.00
Criminal Choice—CC2	2.06	(.15)	.53	.00
Structural Model (Direct Effects)				
Emotionality → Negative State Affect	1.23	(.18)	.31	.00
Emotionality → Perceived Risk	4.29	(1.12)	.18	.00
Emotionality → Criminal Choice	2.15	(.94)	.13	.02
Honesty-Humility → Negative State Affect	.93	(.15)	.29	.00
Honesty-Humility → Perceived Risk	5.01	(.96)	.26	.00
Honesty-Humility → Criminal Choice	-2.74	(.80)	-.20	.00
Conscientiousness → Perceived Risk	2.83	(.73)	.14	.00
Negative State Affect → Criminal Choice	-2.88	(.33)	-.67	.00
Perceived Risk → Criminal Choice	-.24	(.05)	-.33	.00
Negative State Affect → Perceived Risk	5.91	(.55)	.64	.00
Structural Model (Indirect Effects)				
Emotionality → Criminal Choice	-4.55	(.77)	-.27	.00
Honesty-Humility → Criminal Choice	-3.86	(.72)	-.28	.00
Conscientiousness → Criminal Choice	-.67	(.26)	-.05	.00
Structural Model (Total Effects)				
Emotionality → Criminal Choice	-2.39	(1.21)	-.14	.04
Honesty-Humility → Criminal Choice	-6.59	(1.36)	-.49	.00
Conscientiousness → Criminal Choice	-.67	(.26)	-.05	.00

NOTES: χ^2 (d.f. = 43) = 100.70, $p < .01$; CFI = .95, GFI = .97, TLI = .92, and RMSEA = .05. $N = 495$.

ABBREVIATIONS: CFI = comparative fit index; GFI = goodness-of-fit index; RMSEA = root-mean-square error of approximation; SE = standard error; TLI = Tucker-Lewis index.

In sum, not only do Honesty-Humility and Emotionality directly affect criminal choice, but they also lead to higher levels of Negative State Affect and higher Perceived Risk, both of which, in turn, are negatively related to Criminal Choice. Conscientiousness, however, only influences criminal choices indirectly through Perceived Risk. Higher levels of Conscientiousness lead to higher Perceived Risk, which in turn leads to less criminal choice.

Table 3. Unstandardized and standardized path coefficients and significance levels for Model in Figure 3

Estimates	Unstandardized Coefficients (S.E.)		Standardized Coefficients	<i>p</i>
Measurement Model				
Self-Control—HEXSC1	1.23	(.12)	.96	.00
Self-Control—HEXSC2	1.00	—	.81	.00
Negative State Affect—nsa1	1.00	—	.97	.00
Negative State Affect—nsa2	.97	(.02)	.98	.00
Perceived Risk—pr1	.86	(.03)	.90	.00
Perceived Risk—pr2	1.00	—	.98	.00
Criminal Choice—CC1	1.00	—	.65	.00
Criminal Choice—CC2	2.08	(.15)	.51	.00
Structural Model (Direct Effects)				
Self-Control → Negative State Affect	1.87	(.27)	.32	.00
Self-Control → Perceived Risk	10.88	(1.94)	.26	.00
Self-Control → Criminal Choice	-4.40	(1.41)	-.18	.00
Negative State Affect → Criminal Choice	-2.88	(.32)	-.68	.00
Perceived Risk → Criminal Choice	-.18	(.05)	-.31	.00
Negative State Affect → Perceived Risk	7.71	(.67)	.65	.00
Structural Model (Indirect Effect)				
Self-Control → Criminal Choice	-7.39	(1.28)	-.30	.00
Structural Model (Total Effect)				
Self-Control → Criminal Choice	-11.79	(1.94)	-.48	.00

NOTES: χ^2 (d.f. = 14) = 38.20, $p < .01$; CFI = .99, GFI = .98, TLI = .99, NFI = .99, and RMSEA = .06. $N = 495$.

ABBREVIATIONS: CFI = comparative fit index; GFI = goodness-of-fit index; NFI = Normed Fit Index; RMSEA = root-mean-square error of approximation; SE = standard error; TLI = Tucker-Lewis index.

MODEL 2: HEXACO SELF-CONTROL, NEGATIVE STATE AFFECT, PERCEIVED RISK, AND CRIMINAL CHOICE

In model 2, we included HEXACO Self-Control as a trait predictor together with the states Perceived Risk and Negative State Affect as mediators of the relation between HEXACO Self-Control and Criminal Choice (figure 3). We employed an analysis strategy analogous to the one used for the previous model, again basing the SEM model on the product moment correlation matrix and using ML estimation. This model showed a very good fit: (χ^2 (d.f. = 14) = 38.20, $p < .01$; CFI = .99, GFI = .98, TLI = .99, and RMSEA = .06).

The results in table 3 indicate that Self-Control is both directly and indirectly related to Criminal Choice (for the same model with gender and age added as control variables, see S.3 in the online supporting information). Again, by using the method proposed by MacKinnon et al. (2002) based on the product of coefficients ($z_\alpha z_\beta$) as a test for significance of the specific indirect effects, we find that both state variables are statistically significant mediators of the relation between Self-Control and Criminal Choice

Figure 3. Structural Paths among the Latent Variables in the Structural Equation Model Involving HEXACO Self-Control, Negative Affect, Perceived Risk, and Criminal Choice

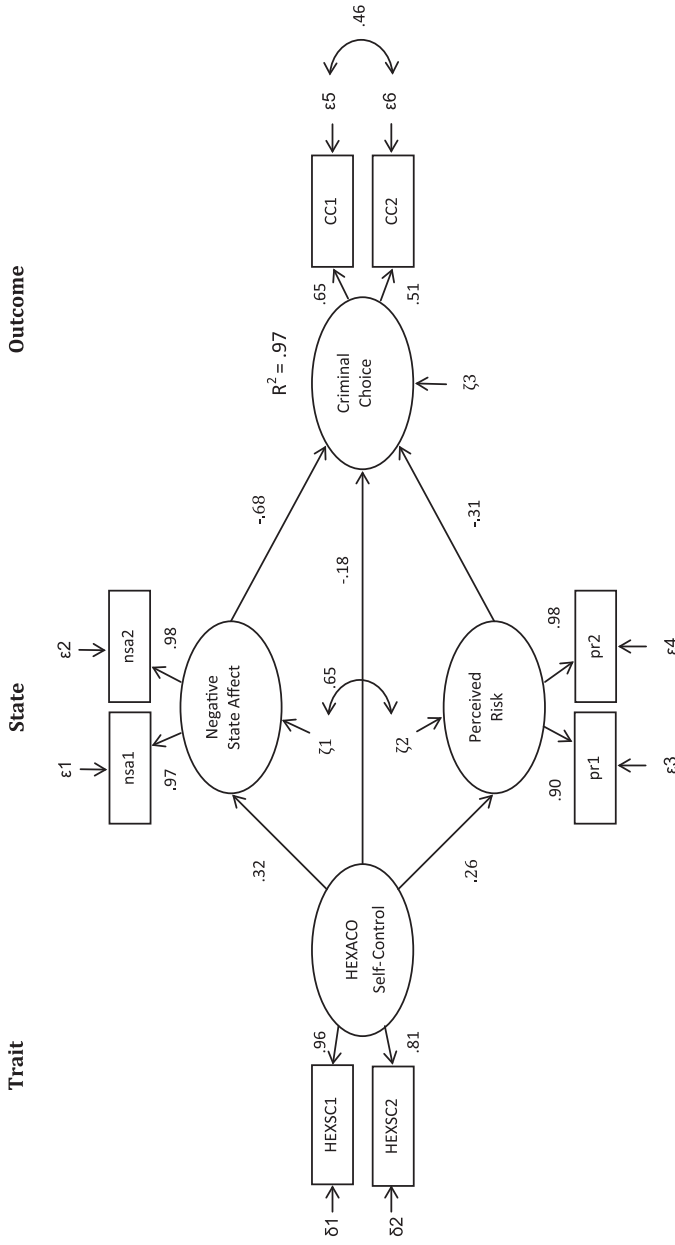

NOTES: The paths from the latent to the observed variables refer to standardized factor loadings. Double-headed arrows refer to the covariance between errors (ζ 's).

($p < .001$). In sum, having more Self-Control leads to higher Perceived Risk and to more experienced Negative State Affect, which in turn are negatively related to Criminal Choice. Furthermore, there is also a direct negative effect of Self-Control on Criminal Choice.

As a final step in the analyses, we compared a model with HEXACO Honesty-Humility, Emotionality, Conscientiousness, and HEXACO Self-Control (model 1) with a model with the three main dimensions but without Self-Control (model 2) and a model with only HEXACO Self-Control (model 3) to examine the parsimony of both the HEXACO model without Self-Control and the Self-Control model without the other HEXACO variables. Because HEXACO Self-Control is made up of facets of the other main dimensions, we included four error covariances between HEXACO Self-Control and the other manifest variables in the SEM. In model 2, we set all path coefficients linking Self-Control to the mediators and the outcome variable to zero. In model 3, we did the same for the other HEXACO variables while freeing up the path coefficients from HEXACO Self-Control. Subsequently, we compared the fit of the three models (model 1: χ^2 (d.f. = 56) = 123.16, $p < .01$; CFI = .95, GFI = .96, TLI = .92, and RMSEA = .05; model 2: χ^2 (d.f. = 59) = 131.18, $p < .01$; CFI = .95, GFI = .96, TLI = .92, and RMSEA = .05; model 3: χ^2 (d.f. = 63) = 188.21, $p < .01$; CFI = .91, GFI = .95, TLI = .87, and RMSEA = .06). The difference between model 1 and model 2 was just significant ($\Delta\chi^2$ (d.f. = 3) = 8.02 and $p = .05$), indicating that the HEXACO model without Self-Control bordered on being better than a model with Self-Control. However, the Self-Control model without the other HEXACO variables was significantly worse than a model that included the HEXACO variables ($\Delta\chi^2$ (d.f. = 7) = 65.05 and $p < .01$). Additionally, the Bayesian Information Criterion (BIC), which takes into account the parsimony of the model, was lower in model 2 (BIC = 416.59) than in model 3 (BIC = 448.80), showing that the HEXACO model without Self-Control had a better relative fit than a comparable model with Self-Control but without the other three HEXACO variables.

DISCUSSION

As in previous studies that have examined the relation between individual dispositions and delinquent behavior (see Miller and Lynam, 2001), we found Conscientiousness, Agreeableness, and Self-Control to be correlated with criminal choice. Furthermore, the Honesty-Humility dimension of the HEXACO model, which is not represented in other models of personality, turned out to be the strongest personality correlate of criminal choice. Honesty-Humility, it will be recalled, refers to individual differences in the proactive willingness to use others for personal gain and includes

self-enhancing and immoral behaviors, such as greed and immodesty and active violations of social norms through insincerity and unfairness. This finding ties in with research that links morality (i.e., reflections of what is right and wrong with respect to values and conduct [e.g., Wikström, 2004]) and egoism (i.e., the excessive concern with one's own pleasure or advantage at the expense of community well-being [De Vries, Ashton, and Lee, 2009; De Vries et al., 2009; Weigel, Hessing, and Elffers, 1999]) to criminal behavior. However, Honesty-Humility carries the advantage over these other measures in that it is integrated in a broader structure of personality, instead of being an isolated trait. This provides insight into how it is related to personality in general, which implies greater precision in terms of the psychological processes at stake compared with isolated measures.

A similar point can be made regarding the HEXACO operationalization of Self-Control. An important strength of the HEXACO model is that it offers a broad conceptualization of personality that encompasses both the Big Five/FFM dimensions and Self-Control and locates the latter within the broader personality space. Although it has been shown previously that the main crime-related element of Self-Control is primarily associated with Big Five/FFM Conscientiousness (Romero et al., 2003), common operationalizations of Self-Control in crime research suggest that it is actually an interstitial trait based mainly on facets from Honesty-Humility, Conscientiousness, and Agreeableness (cf. De Vries, De Vries, and Feij, 2009 – see also the correlations in table 1 of HEXACO Self-Control with the other HEXACO scales). The results of the present study support this broader notion of Self-Control and as such contribute to our understanding of the precise nature of this concept.

We hypothesized perceived risk of sanction and negative affect to mediate the personality–crime relation drawing from dual-process models of information processing. Indeed, both variables were found to mediate the effects of the personality dimensions Emotionality, Honesty-Humility, and Self-Control on criminal choice. Individuals scoring high on Honesty-Humility were both more inclined to feel negatively about the consequences of a criminal choice and to perceive risk of sanction as higher than low scorers. The same effect was found for Emotionality. For Self-Control too, high scorers reported higher levels of negative affect and perceived a higher risk of sanction. In terms of the dual-process model discussed at the beginning of this article, this means that Honesty-Humility, Emotionality, and Self-Control operate both through the hot mode and the cool mode of information processing. For Conscientiousness, only the perceived risk of sanction mediated the relation with criminal choice. Note that although Conscientiousness was only indirectly related to criminal choice,

Honesty-Humility, Emotionality, and Self-Control also operated directly on it.

One remarkable finding with respect to Emotionality should be noted. As hypothesized, we found an indirect negative effect of Emotionality on criminal choice. However, the direct effect of Emotionality on criminal choice was positive in nature. Although caution is advised when interpreting the positive effect, we speculate that people scoring high on Emotionality (i.e., who exhibit a greater tendency to be worried, fearful, sentimental, and dependent) may – out of fear of criminal-minded others or to please them – in some instances be more likely to engage in certain types of illegal behavior.

It could be argued that the high correlation between perceived risk and negative state affect suggests that these are highly similar constructs. Note, however, that there are differences in the extent to which personality explains both and in the extent to which criminal choice is explained by each. These differences underscore our argument regarding the fact that these are different variables and the necessity of differentiating between the two in models of criminal decision making (see for an extensive discussion, Van Gelder, 2012). The stronger relation between negative state affect and criminal choice compared with perceived risk of sanction suggests that the former may more often cue the ultimate behavioral response in a criminogenic situation than the latter.

It is interesting to note that these effects were found using scenarios describing criminogenic situations that actually invite deliberation and the making of cost–benefit assessments (e.g., insurance fraud and illegal downloading). Future studies should address situations where this is less likely or evident and in which divergence between emotional appraisals and cognitive risk assessments is more plausible and larger. It seems, for example, likely that impulsive “hot” crimes (i.e., crimes associated with a high level of affective arousal, such as certain sexual offenses [e.g., date rape], violence-related offenses [e.g., road rage and retaliation], hot-blooded murders [e.g., crimes of passion], and offenses committed by craving drug addicts [e.g., street robbery]) make poor candidates for deterrence precisely because they require individuals to take into consideration the long-term consequences of their actions, whereas intense emotional states, drugs, and sexual arousal all operate to confine attention to the immediate present. In each of these situations, the immediate benefits and long-term costs of behavior are negatively correlated and the benefits appeal to and work on feelings (e.g., sexual gratification and quenching a thirst for revenge), whereas the consideration of the potential costs of rule violation is a cognitive exercise for the most part. For example, Wright and Decker in their study on burglars and street life write:

[T]he offenders, at the time of actually contemplating offenses, typically perceived themselves to be in a situation of immediate need [which] has at least two important implications. First, it suggests a mindset in which they were seeking less to maximize their gains than to deal with a present crisis. Second, it indicates an element of desperation which might have weakened the influence of threatened sanctions and neutralized any misgivings about the morality of breaking into dwellings (1994: 61).

Conversely, crimes committed in an emotionally neutral state belong to the domain of rational, cold, processing and should be, we believe, more susceptible to be influenced by anticipated sanctions.

One advantage of an approach, such as the hot/cool approach advocated in this study, that can examine the influence of feelings alongside rational and cognitive considerations is its ability to shed light on what specific delinquent behaviors can be deterred by altering the balance in the cost-benefit equation of such behaviors, and what kinds of behavior are less susceptible to such influence. For crimes that are intimately related to feelings, impacting the cost-benefit calculus is unlikely to generate much effect as affect, which implicates hot processing, is relatively irresponsive to rational and cognitive considerations such as punishment probability and severity.

Examined in conjunction with a structural model of personality, such as the HEXACO model, it becomes clear that questions regarding what aspects of personality are particularly susceptible to what type of influence, and what aspects are not, can be addressed. For example, individuals dispositionally low in Emotionality are unlikely to be deterred by simply increasing the severity of a sanction or its probability. For these individuals, behavioral interventions that also aim to sensitize them to experiencing negative affect and the risks associated with their unlawful actions may form a productive complementary strategy. A similar point can be made for Honesty-Humility and Self-Control, which operate both indirectly and directly on criminal choice. Furthermore, if Honesty-Humility is the main correlate, interventions should also be aimed at instilling (moral) awareness, promoting greed avoidant behaviors, and diminishing self-centeredness. For Conscientiousness, something else seems to apply: As willful offenders, individuals low in Conscientiousness may be sensitive only to sanction severity and probability.

In criminology, trait and state factors have generally been examined in isolation. Most situational, or state, perspectives, such as rational choice theory, routine activities theory (Cohen and Felson, 1979; Felson, 2002), deterrence, and situational crime prevention (Clarke, 1997), are based on behavioral models that posit a rational offender and generally do not

address offender characteristics or affect, let alone scrutinize the ways in which they may be interrelated. A similar point can be made about theories that look at individual differences; only rarely do proximal factors receive extensive treatment in these perspectives. Yet, as was remarked at the beginning of the article, the fact that there may be stable differences between individuals in terms of their criminal propensity does not exclude the possibility that potential offenders are insensitive to the perceived attractions and deterrents of crime (Nagin and Paternoster, 1993). Furthermore, it is unlikely that situational factors exert the same influence on individuals regardless of their psychological makeup. In other words, instead of being incompatible, trait and state perspectives are actually complementary, and therefore, the two need to be integrated into models that attempt to explain crime. Previous models (e.g., Nagin and Paternoster, 1993; Piquero and Tibbetts, 1996) focusing on differences in individual disposition in combination with proximal states were generally restricted to rational choice variables and self-control. The trait-state model presented and tested in this article broadens our current knowledge by using a new encompassing model of personality, the HEXACO model, and by including state affect next to rational choice considerations as predictors of crime.

Having said that, we consider this article to be only an initial step in the development of a comprehensive trait-state model of criminal decision making. As such, the study was also prone to several limitations that should be kept in mind when considering the results. First, we opted for a scenario method as this allowed us to link personality to state variables and intentions to offend in a single model. We recognize that a weakness of this method is that it measures behavioral intentions rather than actual behavior. However, provided certain conditions are observed, there is a high correlation between a person's intention to perform a behavior and his or her actual performance of that behavior (Fishbein and Ajzen, 1975; see also Nagin and Paternoster, 1993). These conditions are the degree to which the intention to behave is measured with the same specificity as the behavior that is being predicted, the stability of the expressed intention, and the degree to which the individual can willfully carry out the intention (Nagin and Paternoster, 1993: 473–4). The scenarios we developed for this study were developed with these criteria in mind. Another limitation of this study is that the research population consisted of a community sample, instead of an offender population, which implied that the scenarios were not about severe antisocial behavior, but about relatively common everyday crimes instead. This poses limits on the generalizability of the results, such as how personality plays out in the case of persistent offenders. As a next step, it would be productive to test the model among an offender population instead of among a community sample, and for offenses more serious than the ones used in this study. Determining whether the structural

properties and correlates of the variables used are similar in offender and community samples can shed light on whether similar or dissimilar psychological processes are at play in these different populations (Ručević, 2010). Furthermore, this study addressed a prevalent and important type of affect with respect to criminal decision making (i.e., feelings of fear and insecurity triggered by the decision situation) but not other types of affect that are also likely to play a role such as excitement, thrills, and anger. The correlations among personality, affect, and crime will depend on the type of affect under study. Therefore, to generate a more encompassing view of the role of feelings on criminal decision making, future research should address other types of affect.

To conclude, we concur with Miller and Lynam (2001) that more specificity in the outcome variable is also warranted in future research on the personality–crime relationship, which should examine what particular aspects of personality are more strongly related to what specific type of crime. For example, even though some authors have contended that a lack of self-control is equally related to virtually all types of crime (Gottfredson and Hirschi, 1990), and that beyond self-control few dimensions of personality are useful in the explanation of crime (Hirschi, 2004), it is not unlikely that Honesty-Humility is more strongly correlated with those types of crime in which financial self-enhancement plays a role, such as fraud and white-collar crimes, whereas self-control is a more important correlate of crimes in which impulsivity and intense emotions are at stake.

Furthermore, disentangling the different elements of self-control implies that future research can obtain a better grasp of what specific aspects are related to which specific types of crime and at what point during the life-cycle certain aspects bear stronger relations than others (see also Jones, Miller, and Lynam, 2012). The use of different traits in an encompassing model of personality instead of one unitary personality concept opens up the possibility of differentially predicting specific types of offenses, something that the single self-control concept has been unable to do. Establishing meaningful relationships between specific traits and specific types of offenses could, besides providing important theoretical input, also imply an important step forward in the treatment of offenders. Exploring these questions in more detail, we think, will make for a productive line of future empirical inquiry and a welcome step in the further development of trait-state models of criminal decision making.

REFERENCES

- Agnew, Robert A. 1992. Foundation for a general strain theory of crime and delinquency. *Criminology* 30:47–88.

- Agnew, Robert A., Timothy Brezina, John Paul Wright, and Francis T. Cullen. 2002. Strain, personality traits, and delinquency: Extending general strain theory. *Criminology* 40:43–71.
- Arbuckle, James L. 2007. *Amos 16.0 User's Guide*. Chicago, IL: SPSS.
- Ashton, Michael C., and Kibeom Lee. 2008. The prediction of honesty-humility-related criteria by the HEXACO and five-factor models of personality. *Journal of Research in Personality* 42:1216–28.
- Ashton, Michael C., Kibeom Lee, Lewis R. Goldberg, and Reinout E. de Vries. 2009. Higher-order factors of personality: Do they exist? *Personality and Social Psychology Review* 13:79–91.
- Ashton, Michael C., Kibeom Lee, Marco Perugini, Piotr Szarota, Reinout E. de Vries, Lisa di Blas, Kathleen Boises, and Boele de Raad. 2004. A six-factor structure of personality-descriptive adjectives: Solutions from psycholexical studies in seven languages. *Journal of Personality and Social Psychology* 86:356–66.
- Athens, Lonnie. 2005. Violent encounters, violent engagements, and tiffs. *Journal of Contemporary Ethnography* 34:631–78.
- Becker, Gary. 1968. Crime and punishment: An economic approach. *The Journal of Political Economy* 76:169–217.
- Bentler, Peter M., and Chih-Ping Chou. 1987. Practical issues in structural modeling. *Sociological Methods & Research* 16:78–117.
- Caspi, Avshalom, Terry E. Moffitt, Phil A. Silva, Magda Stouthamer-Loeber, Robert F. Krueger, and Pamela S. Schmutte. 1994. Are some people crime prone? Replications of the personality-crime relationship across countries, gender, race, and methods. *Criminology* 32:163–95.
- Chaiken, Shelley, and Yaacov Trope. 1999. *Dual-Process Theories in Social Psychology*. New York: Guilford Press.
- Clarke, Ronald V. 1997. Introduction. In *Situational Crime Prevention: Successful Case Studies*, ed. Ronald V. Clarke. Albany, NY: Harrow and Heston.
- Cohen, Lawrence E., and Marcus Felson. 1979. Social change and crime rate trends: A routine activities approach. *American Sociological Review* 44:588–608.
- Cornish, Derek B., and Ronald V. Clarke. 1986. *The Reasoning Criminal*. New York: Springer-Verlag.

- Costa, Paul T., and Robert R. McCrae. 1990. Personality disorders and the Five-Factor Model of Personality. *Journal of Personality Disorders* 4:362–71.
- Costa, Paul T., and Robert R. McCrae. 1992. *NEO Personality Inventory: Revised (NEO-PI-R) and NEO Five Factor Inventory (NEO-FFI) Professional Manual*. Odessa, FL: Psychological Assessment Resources.
- Costa, Paul T., and Robert R. McCrae. 1998. Six approaches to the explication of facet-level traits: Examples from Conscientiousness. *European Journal of Personality* 12:117–34.
- De Vries, Reinout E., Michael C. Ashton, and Kibeom Lee. 2009. De zes belangrijkste persoonlijkheidsdimensies en de HEXACO Persoonlijkheidsvragenlijst. *Gedrag and Organisatie* 22:232–74.
- De Vries, Reinout E., Anita de Vries, Annebel H. B. de Hoogh, and Jan A. Feij. 2009. More than the big five: Egoism and the HEXACO model of Personality. *European Journal of Personality* 23:635–54.
- De Vries, Reinout E., Anita de Vries, and Jan A. Feij. 2009. Sensation seeking, risk-taking, and the HEXACO model of personality. *Personality and Individual Differences* 47:536–40.
- De Vries, Reinout E., and Dirk van Kampen. 2010. The HEXACO and 5DPT models of personality: A comparison and their relationships with psychopathy, egoism, pretentiousness, immorality, and Machiavellianism. *Journal of Personality Disorders* 24:244–57.
- Elster, Jon. 1989. *Nuts and Bolts for the Social Sciences*. Cambridge, U.K.: Cambridge University Press.
- Epstein, Seymour. 1994. Integration of the cognitive and psychodynamic unconscious. *American Psychologist* 49:709–24.
- Eysenck, Hans J. 1977. *Crime and Personality*. London, U.K.: Routledge and Kegan Paul.
- Eysenck, Hans J. 1996. Personality and crime: Where do we stand? *Psychology, Crime, & Law* 2:143–52.
- Felson, Marcus. 2002. *Crime and Everyday Life*. Thousand Oaks, CA: Sage and Pine Forge Press.
- Fishbein, Martin., and Icek Ajzen. 1975. *Belief, Attitude, Intention, and Behavior: An Introduction to Theory and Research*. Reading, MA: Addison-Wesley.

- Frijda, Nico H. 1988. The laws of emotion. *American Psychologist* 43: 349–58.
- Gibbs, John, J., Dennis Giever, and George E. Higgins. 2003. A test of Gottfredson and Hirschi's general theory using structural equation modeling. *Criminal Justice and Behavior* 30:441–58.
- Goldberg, Lewis R. 1990. An alternative “description of personality”: The big-five factor structure. *Journal of Personality and Social Psychology* 59:1216–29.
- Gottfredson, Michael R., and Travis Hirschi. 1990. *A General Theory of Crime*. Palo Alto, CA: Stanford University Press.
- Grasmick, Harold G., and Robert J. Bursik, Jr. 1990. Conscience, significant others, and rational choice: Extending the deterrence model. *Law & Society Review* 24:837–61.
- Grasmick, Harold G., Charles R. Tittle, Robert J. Bursik, Jr., and Bruce J. Arneklev. 1993. Testing the core empirical implications of Gottfredson and Hirschi's General Theory of Crime. *Journal of Research on Crime and Delinquency* 30:5–29.
- Hagtvet, Knut A., and Fadia M. Nasser. 2004. How well do item parcels represent conceptually defined latent constructs? A two-facet approach. *Structural Equation Modeling* 11:168–93.
- Hirschi, Travis. 2004. Self-control and crime. In *Handbook of Self-Regulation: Research, Theory, and Applications*, eds. Roy F. Baumeister and Kathleen D. Vohs. New York: Guilford Press.
- Hoyle, Rick H., and Abigail T. Panter. 1995. Writing about structural equation modeling. In *Structural Equation Modeling: Concepts, Issues, and Applications*, ed. Rick H. Hoyle. Thousand Oaks, CA: Sage.
- Hu, Li-Tze, and Peter M. Bentler. 1999. Cutoff criteria for fit indexes in covariance structure analysis: Conventional criteria versus new alternatives. *Structural Equation Modeling* 6:1–55.
- Jones, Shane E., Joshua D. Miller, and Donald R. Lynam. 2012. Personality, antisocial behavior, and aggression: A meta-analytic review. *Journal of Criminal Justice* 39:329–37.
- Kahneman, Daniel. 2003. Perspectives on judgment and choice: Mapping bounded rationality. *American Psychologist* 58:697–720.
- Katz, Jack. 1988. *Seductions of Crime: Moral and Sensual Attractions in Doing Evil*. New York: Basic Books.

- Lee, Kibeom, and Michael C. Ashton. 2004. Psychometric properties of the HEXACO Personality Inventory. *Multivariate Behavioral Research* 39:329–58.
- Lee, Kibeom, and Michael C. Ashton. 2005. Psychopathy, Machiavellianism, and Narcissism in the Five-Factor Model and the HEXACO model of personality structure. *Personality and Individual Differences* 38:1571–82.
- Loewenstein, George, Elke Weber, Christopher K. Hsee, and Ned Welch. 2001. Risk as feelings. *Psychological Bulletin* 127:267–86.
- MacKinnon, David P., Chondra Lockwood, Jeanne M. Hoffman, Stephen G. West, and Virgil Sheets. 2002. A comparison of methods to test mediation and other intervening variable effects. *Psychological Methods* 7:83–104.
- McCrae, Robert R., and Paul T. Costa. 1990. *Personality in Adulthood*. New York: Guilford Press.
- Metcalfe, Janet, and Walter Mischel. 1999. A hot/cool system analysis of delay of gratification: Dynamics of willpower. *Psychological Review* 106:3–19.
- Miller, Joshua D., and Donald Lynam. 2001. Structural models of personality and their relation to antisocial behavior: A meta-analytic review. *Criminology* 39:765–98.
- Moffitt, Terrie E., Robert F. Krueger, Avshalom Caspi, and Jeffrey Fagan. 2000. Partner abuse and general crime: How are they the same? How are they different? *Criminology* 38:199–232.
- Nagin, Daniel S., and Raymond Paternoster. 1993. Enduring individual differences and rational choice theories of crime. *Law & Society Review* 27:467–96.
- Nagin, Daniel S., and Greg Pogarsky. 2001. Integrating celerity, impulsivity, and extralegal sanction threats into a model of general deterrence: Theory and evidence. *Criminology* 39:404–30.
- Paternoster, Raymond, and Greg Pogarsky. 2009. Rational choice, agency, and thoughtfully reflective decision making: The short and long term consequences of making good choices. *Journal of Quantitative Criminology* 25:103–27.
- Paternoster, Raymond, and Sally S. Simpson. 1996. Sanction threats and appeals to morality: Testing a rational choice model of corporate crime. *Law & Society Review* 30:378–99.

- Piquero, Alex R., and Stephen G. Tibbetts. 1996. Specifying the direct and indirect effect of low self-control and situational factors in offenders' decision making: Toward a more complete model of rational offending. *Justice Quarterly* 13:481–510.
- Pratt, Travis C., and Francis T. Cullen. 2000. The empirical status of Gottfredson and Hirschi's General Theory of Crime. *Criminology* 38:931–64.
- Romero, Estrella, Antonio Gómez-Fraguela, Angeles Luengo, and Jorge Sobral. 2003. The self-control construct in the general theory of crime: An investigation in terms of personality psychology. *Psychology, Crime, & Law* 9:61–86.
- Ručević, Silvija. 2010. Psychopathic personality traits and delinquent and risky sexual behaviors in a Croatia sample of non-referred boys and girls. *Law and Human Behavior* 34:379–91.
- Schumacker, Randall E., and Richard G. Lomax. 2004. *A Beginner's Guide to Structural Equation Modelling*. New York: Taylor & Francis.
- Slovic, Paul, Melissa L. Finucane, Ellen Peters, and Donald G. Macgregor. 2002. Risk as analysis and risk as feelings: Some thoughts about affect, reason, risk, and rationality. *Risk Analysis* 24:1–12.
- Smith, Eliot R., and Roland Neumann. 2005. Emotion considered from the perspective of dual-process models. In *Emotion: Conscious and Unconscious*, eds. Lisa Feldman Barrett, Paula Niedenthal, and Piotr Winkielman. New York: Guilford Press.
- Strack, Fritz, and Roland Deutsch. 2004. Reflective and impulsive determinants of social behavior. *Personality and Social Psychology Review* 8:220–47.
- Tellegen, Auke. 1985. Structures of mood and personality and their relevance to assessing anxiety with an emphasis on self-report. In *Anxiety and the Anxiety Disorders*, eds. A. Hussain Tuma and Jack D. Maser. Hillsdale, NJ: Lawrence Erlbaum.
- Van Gelder, Jean-Louis. 2012. Beyond rational choice: The hot/cool perspective of criminal decision making. *Psychology, Crime, & Law*. in press.
- Van Gelder, Jean-Louis, Reinout E. de Vries, and Joop van der Pligt. 2009. Evaluating a dual-process model of risk: Affect and cognition as determinants of risky choice. *Journal of Behavioral Decision Making* 22:45–61.

- Weigel, Russel H., Dick J. Hessing, and Henk Elffers. 1999. Egoism: Concept, measurement and implications for deviance. *Psychology, Crime, & Law* 5:349–78.
- Wikström, Per-Olof H. 2004. Crime as alternative: Towards a cross-level situational action theory of crime causation. In *Beyond Empiricism: Institutions and Intentions in the Study of Crime*. vol. XIII, *Advances in Criminological Theory*, ed. Joan McCord. New Brunswick, NJ: Transaction.
- Wright, Richard, and Scott H. Decker. 1994. *Burglars on the Job: Streetlife and Residential Break-ins*. Boston, MA: Northeastern University Press.
- Wright, Richard, and Scott H. Decker. 1997. *Armed Robbers in Action: Stickups and Street Culture*. Boston, MA: Northeastern University Press.

Jean-Louis van Gelder is a research fellow at the Netherlands Institute for the Study of Crime and Law Enforcement (NSCR). His research interests include the role of affect and cognition in criminal decision making, personality and crime, multiple-self models and future self-continuity, and informality in developing countries.

Reinout E. de Vries is an associate professor in the Social and Organizational Psychology Department of the Faculty of Psychology and Education at VU University Amsterdam. His main research interests include personality, communication styles, and leadership.

SUPPORTING INFORMATION

The following supporting information is available for this article:

S.1. Scenarios

S.2. Unstandardized and Standardized Regression Coefficients and Significance Levels for Model in Figure 2 with Gender and Age Added as Control Variables

S.3. Unstandardized and Standardized Regression Coefficients and Significance Levels for Model in Figure 3 with Gender and Age Added as Control Variables

Supporting Information may be found in the online version of the article.

Please note: Wiley-Blackwell is not responsible for the content or functionality of any supporting information supplied by the authors. Any queries (other than missing material) should be directed to the corresponding author for the article.