

13kW Advanced Electric Propulsion Flight System Development and Qualification

IEPC-2017-223

*Presented at the 35th International Electric Propulsion Conference
Georgia Institute of Technology • Atlanta, Georgia • USA
October 8 – 12, 2017*

Jerry Jackson¹, May Allen², Roger Myers³, Erich Soendker⁴, Benjamin Welander⁵, Artie Tolentino⁶,
Sam Hablitzel⁷, Chyrl Yeatts⁸ and Steven Xu⁹

Aerojet Rocketdyne, Los Angeles, CA and Redmond, WA, United States

Chris Sheehan¹⁰

ZIN Technologies, Cleveland, Ohio, 44135, United States

Joseph Cardin¹¹

VACCO, El Monte, California, 91733, United States

John Steven Snyder¹² and Richard R. Hofer¹³

Jet Propulsion Laboratory, California Institute of Technology, Pasadena CA, United States

and

Todd Tofil¹⁴, Dan Herman¹⁵

NASA Glenn Research Center, Cleveland, Ohio, 44135, United States

Abstract: The next phase of robotic and human deep space exploration missions is enhanced by high performance, high power solar electric propulsion systems for large-scale science missions and cargo transportation. Aerojet Rocketdyne's Advanced Electric Propulsion System (AEPS) program is completing development, qualification and delivery of five flight 13.3kW EP systems to NASA. The flight AEPS includes

¹ AEPS Program Manager, Jerry.Jackson@rocket.com.

² AEPS Chief Engineer, May.Allen@rocket.com.

³ AEPS Technical Consultant, Roger.Myers@rocket.com.

⁴ AEPS PPU Lead, Erich.Soendker@rocket.com.

⁵ AEPS Thruster and System Architecture Lead, Benjamin.Welander@rocket.com.

⁶ AEPS Feed System Lead, Arturo.Tolentino@rocket.com.

⁷ AEPS PPU Discharge Supply Lead, Sam.Hablitzel@rocket.com.

⁸ AEPS System Lead, Chyrl.Yeatts@rocket.com.

⁹ AEPS Early System Test Lead, Steven.Xu@rocket.com.

¹⁰ ZIN Technologies, PPU Program Manager, Sheehanc@zin-tech.com.

¹¹ VACCO, Director of New Business, JCardin@vacco.com.

¹² NASA JPL Thruster Lead, Richard.R.Hofer@jpl.nasa.gov

¹³ NASA JPL Lead System Engineer, John.S.Snyder@jpl.nasa.gov

¹⁴ NASA Project Lead Engineer, Daniel.A.Herman@nasa.gov.

¹⁵ NASA Program Manager, Todd.A.Tofil@nasa.gov.

a magnetically-shielded, long-life Hall thruster, power processing unit (PPU), xenon flow controller (XFC), and intrasystem harnesses. The Hall thruster, originally developed and demonstrated by NASA's Glenn Research Center and the Jet Propulsion Laboratory, operates at input powers up to 12.5kW while providing a specific impulse over 2600s at an input voltage of 600V. The power processor is designed to accommodate an input voltage range of 95 to 140V, consistent with operation beyond the orbit of Mars. The integrated system is continuously throttleable between 3 and 13.3kW. The program has completed the system requirement review; the system, thruster, PPU and XFC preliminary design reviews; development of engineering models, and Early Integrated System Testing (EIST). This paper will present the high power AEPS capabilities, overall program and design status and the latest test results for the 13.3kW flight system development and qualification program.

Nomenclature

AEPS	=	Advanced Electric Propulsion System
AR	=	Aerojet Rocketdyne
CDR	=	Critical Design Review
DMC	=	Discharge Master Controller
DSU	=	Discharge Supply Module
EDU	=	Engineering Development Unit
EIST	=	Early Integrated System Test
EP	=	Electric Propulsion
FPGA	=	Field Programmable Gate Array
FT	=	Flight Thruster
GRC	=	Glenn Research Center
HEOMD	=	Human Exploration and Operations Mission Directorate
HERMeS	=	Hall Effect Rocket with Magnetic Shielding
JPL	=	Jet Propulsion Laboratory
PDR	=	Preliminary Design Review
PMA	=	Propellant Management Assembly
PPU	=	Power Processing Unit
SCB	=	System Control Board
SEP	=	Solar Electric Propulsion
STMD	=	Space Technology Mission Directorate
TDU	=	Technology Development Unit
VF	=	Vacuum Facility
XFC	=	Xenon Flow Controller
XFCM	=	Xenon Flow Control Module

I. Introduction

The next phase of robotic and human deep space exploration missions is enhanced by high performance, high power solar electric propulsion systems for large-scale science missions and cargo transportation. A high-power Solar Electric Propulsion (SEP) element is integral to NASA's phased Mars exploration vision, illustrated in Figure 1 which presents an approach to establish an affordable evolutionary human exploration architecture.¹ Recent studies for NASA's Human Exploration and Operations Mission Directorate (HEOMD) and Science Mission Directorate (SMD) have demonstrated that SEP capability, with its substantially higher specific impulse (I_{sp}), can be enabling for both near term and future architectures and science missions.²

The development of a 13.3 kW Hall thruster system, led by the NASA Glenn Research Center (GRC) and the Jet Propulsion Laboratory (JPL), began with the maturation of a high-power Hall thruster and power processing unit internal to NASA. This technology development work has since transitioned to Aerojet Rocketdyne via a competitive procurement selection for the Advanced Electric Propulsion System (AEPS) contract. The AEPS contract includes the development, qualification, and delivery of five 13.3 kW Hall thruster flight strings.

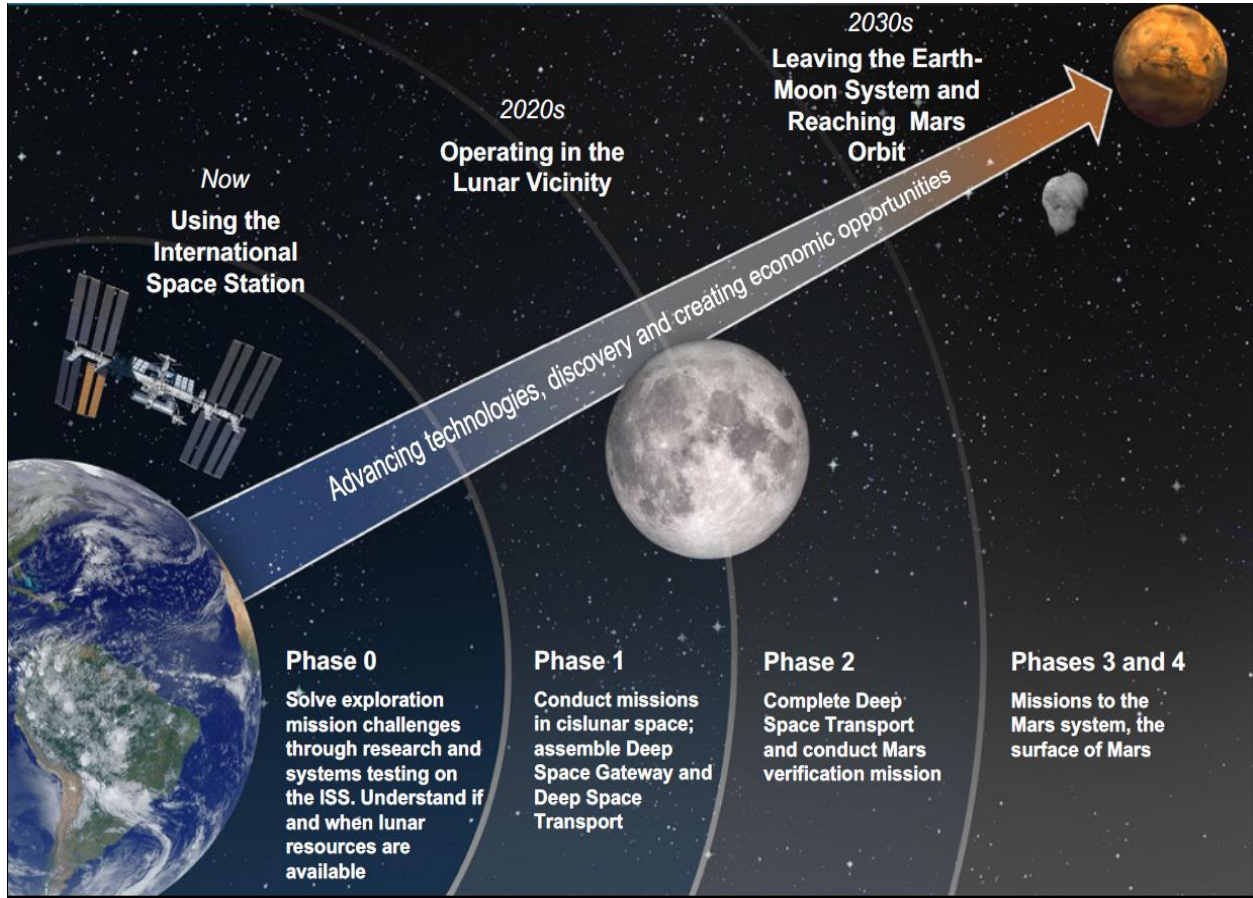

Figure 1. NASA Human Exploration Reference Concept¹

The AEPS System is an EP string that consists of a magnetically shielded Hall thruster, Power Processing Unit (PPU), Xenon Flow Controller (XFC), and associated harnessing. The PPU receives up to 13.3 kW of power to control the thruster output and operations. The 12.5kW Hall thruster uses xenon propellant and power from the PPU to provide over 600 mN of thrust. The XFC is a low pressure flow system that is controlled by the PPU. An overview of the electric propulsion (EP) string and how it interfaces with a notional spacecraft is shown in Figure 2. The AEPS program has completed the System Requirement Review (SRR); the EP string, thruster, PPU and XFC Preliminary Design Review (PDR); engineering model development; and early system integration testing.

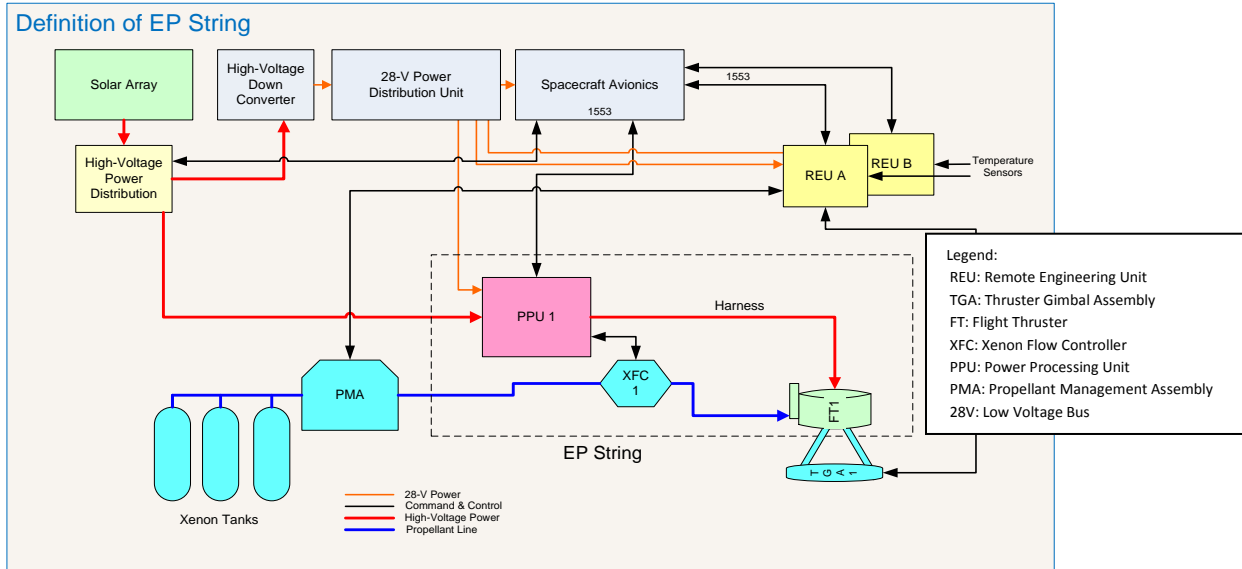

Figure 2. EP String Definition³

The AEPS Hall thruster is based upon the 12.5 kW Hall Effect Rocket with Magnetic Shielding (HERMeS), shown in Figure 3, that was originally developed and demonstrated by NASA GRC and JPL. The thruster operates at input powers up to 12.5 kW while providing a specific impulse of over 2600 s at a discharge voltage of 600 V. The thruster design resulted in an estimated life of 50,000 hours⁴ enabled by magnetic shielding which was first demonstrated by Aerojet Rocketdyne and JPL on the BPT-4000 (XR-5).⁵ NASA continues to perform further development testing of the HERMeS Technology Development Units (TDUs) including wear testing, environmental testing and cathode development in order to better understand implications for spacecraft accommodations and mitigate risk for the AEPS program.⁶



Figure 3. HERMeS Thruster

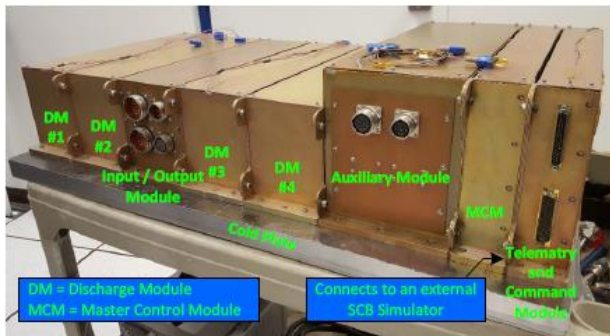

Figure 4. Brassboard PPU

The AEPS PPU leverages the work performed by NASA GRC on a brassboard power processor that was utilized in the integration testing of the HERMeS thruster.⁷ The brassboard High Power 120/800 V Power Processing Unit (HP 120/800 V PPU) was required to have all of the functionality to operate a Hall thruster, including the auxiliary power, master control board, telemetry, and filters (see Figure 4). The unique aspect of this development was the wide range (95 to 140 V) of the input voltage for the PPU. The test results of the HP 120/800 V PPU helped to guide the design of the AEPS PPU.

Unlike the HCT or PPU, the fidelity of the Xenon Flow Controller (XFC) for AEPS is already at a high Technology Readiness Level (TRL). The AEPS XFC is a derivative of the Xenon Flow Control Module (XFCM), see figure 5, which was previously developed under a NASA contract by VACCO.⁸ The XFCM is a highly integrated feed system that accepts unregulated xenon directly from storage tanks and outputs precision, throttleable flow through two independent channels. The XFCM completed qualification testing and was delivered to NASA GRC on 7 June 2012.



Figure 5. VACCO XFCM

AEPS is a NASA contract that was competitively-selected⁹ and consists of the development of an Engineering Development Unit (EDU) EP string, qualification of a flight system and then delivery of four 13.3kW EP flight systems to NASA. The AEPS program was awarded to Aerojet Rocketdyne on April 28 of 2016. In execution of this program, there is close collaboration between Aerojet Rocketdyne, NASA GRC, and JPL. The industry AEPS team includes two Aerojet Rocketdyne sites, Redmond and Los Angeles, as well as ZIN Technologies, who is providing elements of the PPU, and VACCO, who is providing the XFC. The management of the contract is being led by the NASA Glenn Research Center.

This paper summarizes the status of the AEPS program, including updates to the thruster and PPU, as well as the results of recent early integrated system testing that verified successful operation of an EP string and identified necessary design updates that will be incorporated prior to the Critical Design Reviews (CDRs) next year. This paper will present the high power AEPS capabilities, overall program and design status and the latest test results for the 13.3kW flight system development.

II. System Architecture

The primary design objective for the system architecture is to provide a high performance propulsion system that efficiently utilizes both electrical power and propellant. The system provides the capability to throttle between 3kW and 13.3kW of input power providing a range in discharge voltage between 30V and 600V. The expected performance for AEPS is summarized in Table 1 below. While the system will be qualified down to power levels of 3kW, this power level was not included in the table due to lack of system efficiency estimates. The required system input power and propellant flow rates will be determined by the throttle set points commanded by the spacecraft. Significant effort has been focused on maximizing the electrical efficiency of each component of the propulsion string and ensuring repeatable performance throughout the life of the mission.

Table 1. Expected performance of Advanced Electric Propulsion System

EP String Total Input Power	Discharge Voltage	Thrust	Specific Impulse	Total System Efficiency	System Mass [†]
13.3 kW	600 V	589 mN	2800 s	57%	100 kg †Excludes cable harnesses
11.1 kW	500 V	519 mN	2600 s	55%	
8.9 kW	400 V	462 mN	2300 s	54%	
6.7 kW	300 V	386 mN	1900 s	52%	

A block diagram of the AEPS string is shown in Figure 6 showing external interfaces to the spacecraft. The system receives high voltage power for thruster operation and low voltage power for housekeeping and XFC operation from the spacecraft power buses. The spacecraft command and data handling bus provides commands to the system and

receives telemetry from the system. The system receives pressure regulated xenon propellant from the spacecraft xenon feed system.

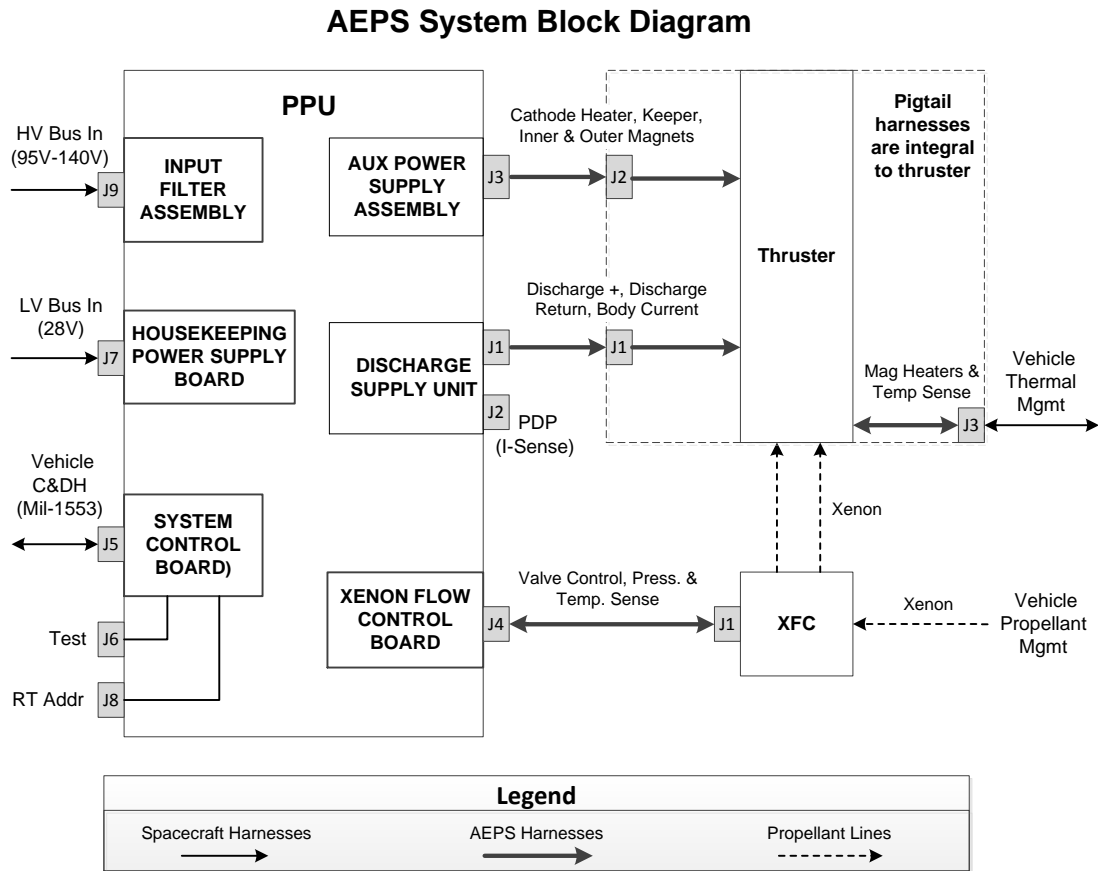

Figure 6. Block diagram of AEPS string showing electrical and propellant interfaces

The AEPS harnessing between the components is designed to allow easier spacecraft integration and gimbaling of the thruster by dividing the PPU-to-thruster power between two harnesses, thereby reducing the thickness and stiffness as compared to using a single harness. One harness is dedicated to the primary discharge power. The other is dedicated to thruster auxiliary power, which includes power required by the cathode heater, cathode keeper, and electromagnets.

Propellant flow rate is controlled and regulated by AEPS via the PPU. Power from the PPU is provided to the XFC on a single harness. The PPU provides the necessary current to open and close the XFC latch valve. The PPU also provides the necessary voltages to control the size of the orifice in the piezoelectric anode and cathode valves, which regulate the propellant flow rate to the anode and cathode propellant lines on the thruster. The architecture facilitates system operation in the event of a spacecraft propellant regulator failure. In the event of such failure, the PPU will monitor the temperature on the XFC and provide sufficient current to an integrated XFC heater, ensuring that the high pressure propellant remains in a gaseous phase as it passes through the anode and cathode flow control valves.

The XFC and PPU are maintained within their required thermal environments via thermal conduction through temperature-controlled mounting surfaces on the spacecraft. The AEPS architecture allows installation of the XFC inside or outside of the spacecraft. The thruster is designed to be thermally uncoupled from the spacecraft. The

thruster is equipped with integrated heaters and temperature sensors that may be operated by the spacecraft thermal management system to maintain the thruster above its minimum qualified temperature limits. This allows the thruster to be located on a gimbal or boom far away from temperature-controlled surfaces and minimize plasma impingement on spacecraft surfaces.

The system architecture includes test connectors to facilitate electrical functional tests of the XFC and thruster. These functional tests may be performed during spacecraft integration and testing without requiring additional mating and de-mating of the harnesses.

The architecture provides the spacecraft with accurate measurements of anode and cathode propellant flow rates and all relevant voltages and currents, see the two columns of telemetry in Table 2. The EP string has 6 modes of operation which are defined in Table 3.

Table 2. Analog Telemetry

Analog Telemetry	
Cathode heater DC current	High voltage bus input DC voltage
Cathode heater DC voltage	High voltage bus input DC current
Cathode keeper DC current	Low voltage bus input DC voltage
Cathode keeper DC voltage	Low voltage but input DC current
Inner Magnet DC Current	Discharge current ripple
Inner Magnet DC Voltage	Discharge voltage ripple
Outer Magnet DC Current	PPU Housekeeping DC Voltage
Outer Magnet DC Voltage	XFC Anode-Leg flow control device Temperature
Discharge DC Current	XFC Anode-Leg Pressure
Discharge DC Voltage	XFC Cathode-Leg flow control device Temperature
Cathode-to-PPU-chassis DC voltage	XFC Cathode-Leg Pressure
Cathode-to-thruster-body DC current	XFC drive currents and voltages
PPU Temperatures	

Table 3. EP String Modes of Operation

Mode	Description
Unpowered	All PPU outputs off and XFC valves closed. No communication.
Boot	Only mode that can accept software updates.
Standby	Bus inputs are in range, communications available, all outputs off.
Initialization	Events such as cathode conditioning, flow system bakeout, etc.
Operation	Startup, steady-state thrusting, throttling, shutdown.
Safe	Places string in a safe state. All outputs off, communications available.

For nominal thrusting operations, when power is applied, the system performs initialization checks and waits for spacecraft commands to perform requested operation.

The system initiates startup following receipt of the spacecraft command. The initialization sequences are performed only once during the initial operation on-orbit. They include venting of the propellant feed system, bakeout of thruster, and cathode conditioning. The operation mode consists of four states shown in Figure 7. The system can transition between any two operational states when commanded by the spacecraft. The “Heater Only” and “Keeper Only” states maintain requisite cathode temperatures for efficient electron emission and keep the EP string in a state of readiness for rapid thruster start. While in the “Thruster Control” state, the system can maintain a constant throttle level, perform a thruster start, throttle to a new operating point or shut down.

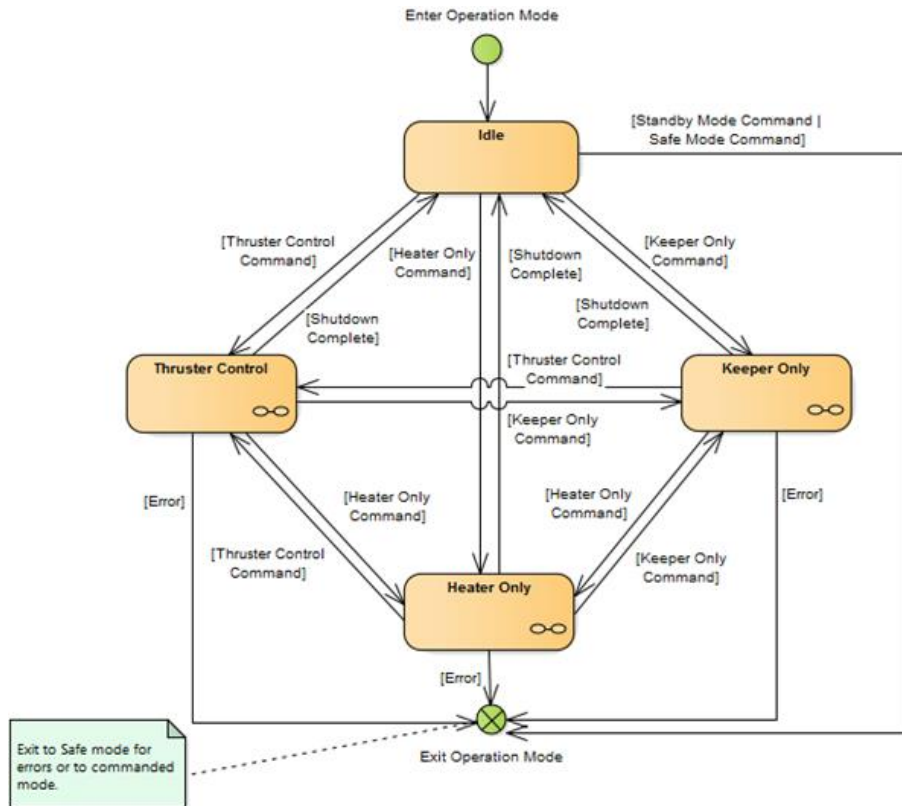

Figure 7. EP String Operation Sequences

In the event of anomalous operation, AEPS will self-protect through an integral fault monitoring system. If telemetry strays outside of the expected range, the PPU will notify the spacecraft of the anomaly. The spacecraft has the option to maintain the current operating point or change operating points in an effort to resolve the anomaly. If telemetry strays too far from its expected range, the PPU will notify the spacecraft of a fault and then perform an automated shutdown of the system to avoid potential damage. The expected operating range for the fault protection system will be established during the Engineering Development test phase. The design of the fault protection system allows for reconfiguration throughout the mission.

The major control loop within AEPS is focused on achieving the desired thruster discharge current commanded by the spacecraft. The PPU does not control discharge current directly. Instead, it regulates propellant flow rate to the thruster. While the electrical interactions between the PPU and thruster are very fast, the propellant flow interactions between the XFC and thruster are very slow. Transients associated with these interactions may occur over several seconds or less than a millisecond. Designing a control loop that provides the prompt command response desired by the mission and stability against a wide spectrum of perturbations is challenging, especially when the system is designed to allow integration on a variety of spacecraft configurations.

To ensure successful development of the AEPS flight system, Aerojet Rocketdyne is developing a time dependent system performance model to address the interactions between components, design adjustments, production tolerances as well as the major interactions with the spacecraft.¹⁰ The AEPS system performance model has been designed to account for all these interactions in a way that allows evaluation of the sensitivity of the system to expected changes over the planned mission as well as to assess the impacts of normal component and assembly variability during the production phase of the program. The results will ensure the component requirements do not unnecessarily drive the system cost or overly constrain the development program. Finally, the model will be available to quickly troubleshoot any future unforeseen development challenges.

System level hot-fire testing will be performed on Engineering Development Unit (EDU) hardware in 2018. Qualification testing will be performed on the first string of flight production units in 2019. All string testing is planned to take place at the NASA GRC Space Simulation Test Facilities. As part of the current program, AR is developing an automated test system specifically for integrated string testing of AEPS.

III. Thruster

The AEPS thruster design is based largely on the NASA HERMeS Technology Development Unit (TDU). The HERMeS TDU is a magnetically shielded, 12.5 kW thruster with a center-mounted cathode and carbon pole covers. The TDU has demonstrated operation at discharge currents in excess of 30A and discharge voltages up to 800 V.¹² The cathode is electrically tied to the conductive pole covers of the TDU. With this novel electrical configuration and effective magnetic shielding, the TDU has demonstrated the low erosion rates necessary to meet the mission requirement of 23,000 hours of operation.¹³

The performance capability of the AEPS thruster is expected to be the same as the NASA HERMeS TDU. By maintaining key gas distributor and magnetic circuit design features of the HERMeS TDU, the AEPS thruster should achieve total efficiencies up to 68% and specific impulses up to 2900 s.¹⁴

The AEPS thruster design has evolved from the TDU in order to improve dynamic stress capability, reduce thermally-induced stresses, ensure long life in both flight and test environments, and improve manufacturability. The most noticeable change is the addition of a shock isolation system and elimination of the thermal radiator. The shock isolators greatly reduce the transmitted acceleration levels at high frequencies. The thruster is designed to survive qualification shock levels up to 1000 g and qualification random vibration levels up to 11.4 g_{rms}. The thermal radiator was found to be unnecessary as the thruster's thermal design was improved.

The AEPS thruster design is capable of operation in deep space anywhere between 0.8 AU and 1.7 AU while mounted to a spacecraft interface between -100°C and +150°C. In proposed spacecraft configurations, the thruster radiates only 22W to the spacecraft when operating at discharge power levels of up to 12.5 kW. Materials and coatings have been selected to ensure that the thruster can provide a minimum of 5,000 starts. Shielding and material selection will ensure that the thruster survives deep space solar radiation for up to 15 years.

The AEPS thruster is designed to operate at discharge currents up to 25A and discharge voltages up to 630V. The thruster is a maximum 516 mm in diameter and 204 mm tall and mass is predicted to be less than 50 kg. The thruster is designed to produce a first natural frequency greater than 70 Hz.

Figure 8 below shows a CAD image of the AEPS thruster and the three electrical harnesses integrated into the thruster. As mentioned in the previous section, operational power from the PPU is provide via the Discharge and Auxiliary Power Cable Assemblies. The thruster is maintained above its minimum qualified temperature via integrated heaters and temperature sensors. These thermal components are operated by the spacecraft's thermal management system.

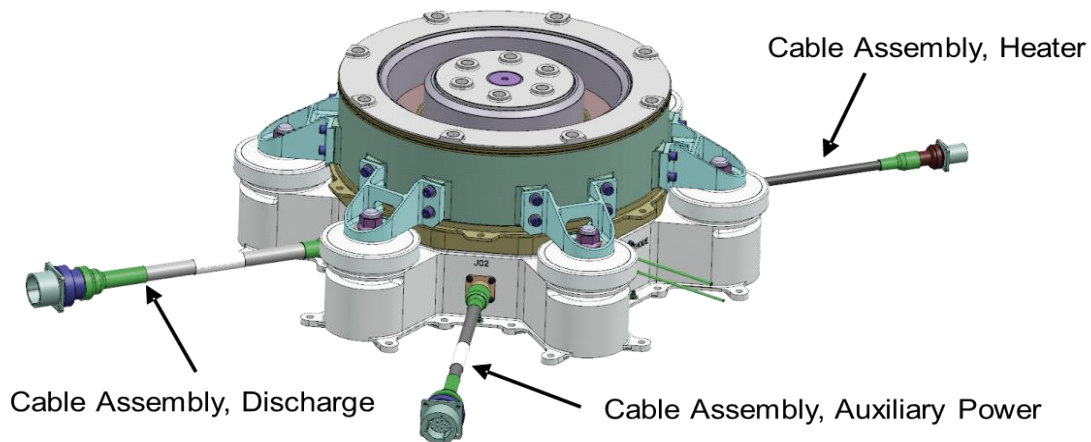

Figure 8. CAD image of AEPS Hall Current Thruster showing integrated harness assemblies

As part of the current program, all of the tooling and test equipment necessary to fabricate and test flight AEPS thrusters are being developed. This support equipment will be verified during manufacturing and test of two EDU thrusters. Procurement and manufacturing of the two EDU thrusters is underway at Aerojet Rocketdyne’s Redmond, Washington facility. Testing is planned to take place in Redmond, at NASA GRC, and at JPL. EDU thrusters will undergo dynamic and thermal qualification level environmental testing, hot-fire performance and wear testing, plasma characterization, and radiated emissions testing in 2018. Qualification testing of the first flight production unit is planned for 2019.

IV. Power Processing Unit

The AEPS PPU provides discharge power to the thruster as well as system control and other associated functions. The PPU provides up to 20.8 A of discharge current over a variable voltage output range of 300 to 600 V. Other features include XFC control, heater power, keeper power, inner magnet power, outer magnet power, telemetry, system health monitoring, and spacecraft communications. The PPU design leverages the lessons learned from GRC’s breadboard PPU development effort⁵.

Unique capabilities of the PPU include its high efficiency target of 95% with a wide input voltage range of operation with a baseplate temperature range of -15 to 50°C. With the mass burden associated with increased input voltage range, the PPU has a specific power (266 W/kg) comparable to current state-of-the-art (SOA). Specific performance parameters are enumerated below:

- Input Power: 13.3kW input (14kW contingency)
- Input voltage: 95V – 140V, Unregulated
- Output Voltage: 300V to 600V, 20.8A (630V or 22A contingency)
- Output Power: 12.5kW at 600V
- Dimensions: 900mm X 518mm X 20mm
- Mass: ~50 kg

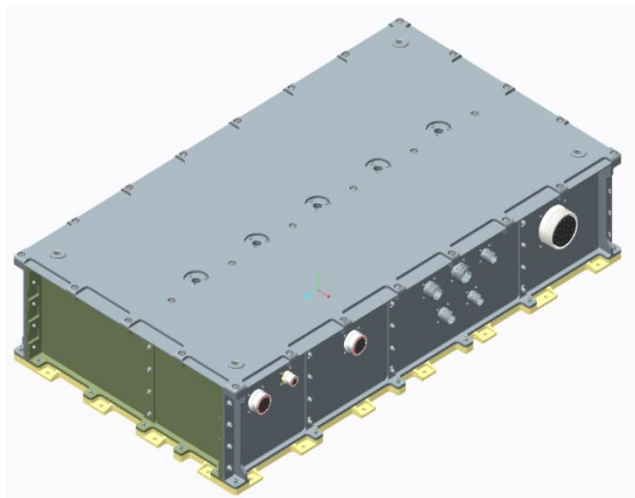

Figure 8. AEPS PPU Assembly

The PPU block diagram in Figure 9 shows signal and power flow. The PPU provides 12.5 kW of regulated electric power to an electric thruster. The PPU controls the thruster output and operations. The XFC is a low pressure flow system that is also controlled by the PPU.

The PPU includes the following list of major component subsystems:

- System Control Board (SCB)
- Discharge Supply Unit (DSU)
 - Discharge Master Controller (DMC)
 - Power Module
 - Output Filter
- Auxiliary Power Supply Assembly
 - Inner/outer Magnet, Heater, Keeper
- Xenon Flow Control Board (XFCB)
- Housekeeping Power Supply Board (HPSB)
- Input Filter Assembly
- Output Filter Assembly
- Cabling and Enclosure

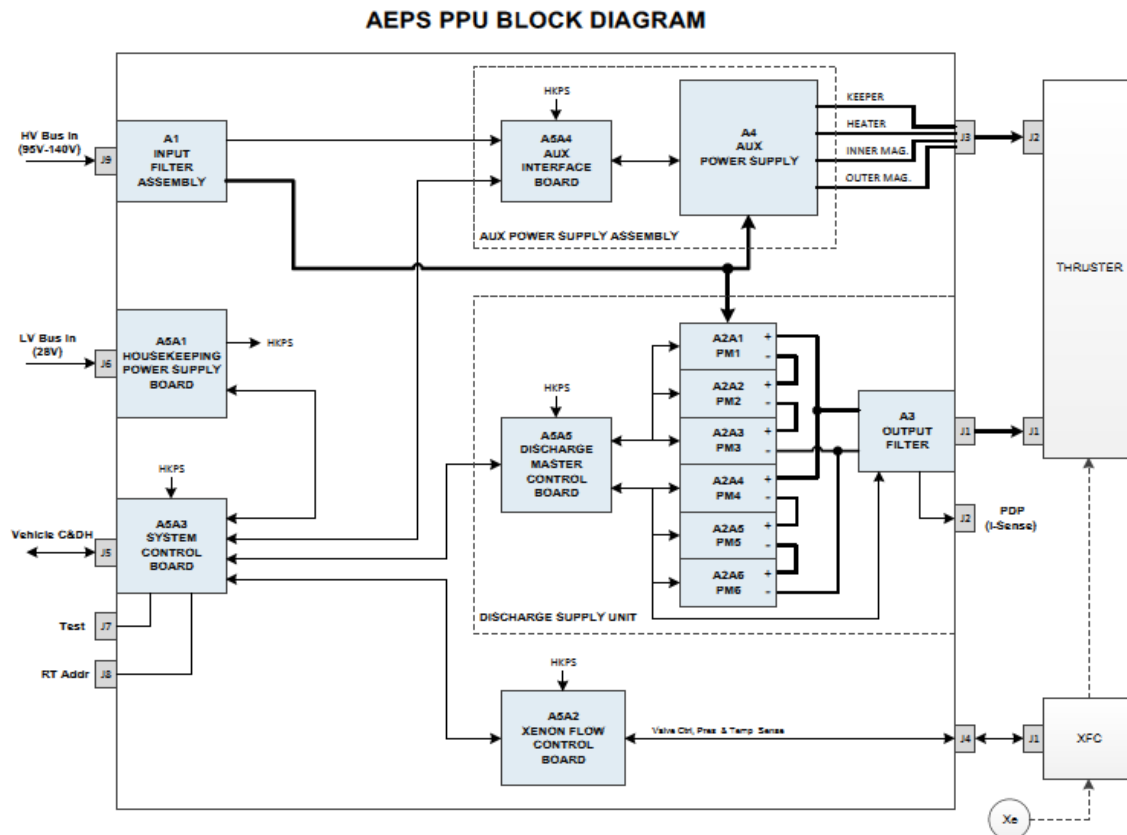

Figure 9. Power Processing Unit Block Diagram

The SCB is the brain of the system and it interfaces with the spacecraft communication bus. Through this bus, commands from the spacecraft are received and telemetry from the PPU is transmitted along with timestamp information. The SCB controls the outputs of the PPU by sending commands to the various power supplies in the system (auxiliary power supplies and discharge supplies). It synchronizes the auxiliary power supplies with the DSU. The SCB monitors sensor information via the internal communications bus. The SCB also provides self-test and fault detection functions, including a watchdog timer function.

The DSU supplies the discharge voltage and current to the thruster. It has a DMC board controlling an array of Power Modules (PM) in a series/parallel combination. Two sets of three series PMs are in parallel with each other. The DMC receives commands from the SCB and translates them into voltage levels for the individual power modules. The DMC provides short circuit protection (spark events).

The Auxiliary Interface Board (AIB) interfaces with the auxiliary power supplies, which provide power to the Cathode Heater, Keeper, Inner Magnet, and Outer Magnet. The XFCB provides closed-loop control of the XFC. The HPSB provides low voltage power to the various boards and modules in the PPU.

The input filter assembly provides EMI/EMC filtering and power quality compliance to ensure compatibility with the S/C power bus. In addition to filtering the power input, this board also provides input voltage and current telemetry.

The output filter assembly provides a low impedance source at the thruster breathing modes while minimizing the voltage ripple. The location of this filter is within the PPU. In addition to filtering the breathing mode currents from the DSU the output filter assembly, the output filter provides DC and AC output voltage and current telemetry. The AC voltage and current characteristics provide thruster performance health monitoring.

When low voltage power is applied, the housekeeping power supply board is activated providing housekeeping power to the SCB. Once powered, the SCB performs initialization checks and waits for spacecraft commands. Following verification that the SCB high voltage bus is active, the system enters startup, conditions the system for operation, and can then start the thruster.

The SCB continuously monitors the health of the entire EP string, allowing on-going diagnostics for changing conditions over the mission life. This monitoring includes reporting warning or fault level status and discharge voltage and discharge current ripple for the thruster to the spacecraft.

During operation, the SCB provides setpoint commands for the heater to condition the cathode, the ignition command to the keeper, and the discharge current setpoint. The magnet supplies provide magnetic field strength

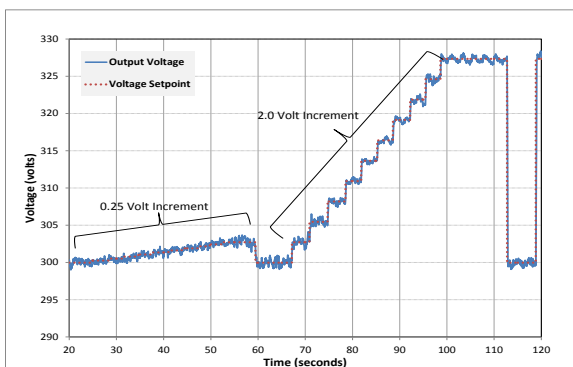

Figure 11. Output Voltage Control

The full range will be verified during design verification testing in 2018. The AEPS PPU will go through extensive design verification testing with an engineering model at qualification levels and will complete full qualification testing with the first flight production unit in 2019.

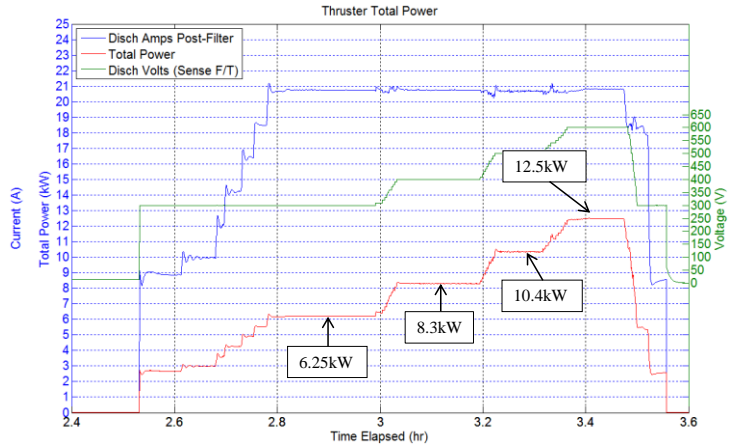

Figure 10. Discharge Supply Output over the normal operating range

necessary for high performance. The SCB commands the DSU to the desired starting voltage and current limit setpoint, commands the XFC flow using pressure feedback to set the initial drive, and closes the thrust control loop with current from the DSU output. Figure 10 shows the discharge supply output voltage, current and power from 3kW up to 12.5 kW during breadboard development testing.

The DMC can adjust the output voltage to a resolution of less than 0.5 V, which provide a continuously variable output voltage from 300 to 630 V. Figure 11 shows a sample of this capability during the Early Integrated System Test.

The AEPS PPU will go through extensive design verification testing with an engineering model at qualification levels and will complete full qualification testing with the first flight production unit in 2019.

V. Xenon Flow Controller

VACCO has been providing electric propulsion components and feed systems for over 20 years. In order to minimize the size and mass of future xenon feed systems, VACCO developed and qualified a Xenon Flow Control Module (XFCM) based on our Chemically Etched Micro Systems (ChEMS™) technology.

VACCO teamed with Aerojet Rocketdyne on AEPS with responsibility for the Xenon Flow Controller (XFC), an application-engineered version of VACCO's fully-qualified XFCM (see Figure 10). The result is a highly-integrated, compact, low-mass subsystem that provides:



Figure 10. VACCO XFCM

- 10 Micron propellant filtration
- Propellant heater for off-nominal conditions
- A Micro Latch Valve for propellant isolation
- Independently throttleable flow to both the Anode and Cathode
- Flow rate feedback

With minor adjustment the XFC is capable of supporting a wide range of flow regimes and electric thrusters well beyond 12.5 kW. The AEPS XFC weighs less than 2 kg and measures less than 8 x 8 x 20 cm, with one inlet tube and two outlet tubes. It consists of two major sub-assemblies; a manifold and an enclosure.

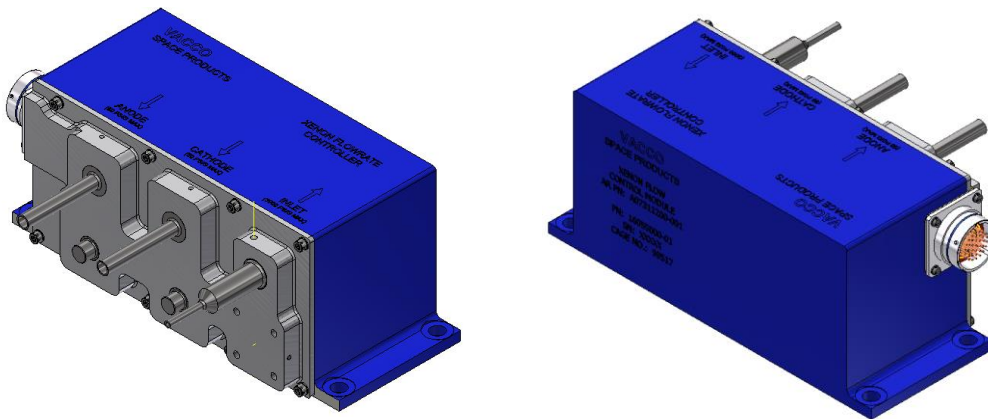

Figure 11. AEPS Conceptual Enclosure for the XFC

The manifold is all-welded against external leakage with inlet and outlet tubes welded to the outside and the functional components mounted on the inside. Interconnecting flow paths between components are machined into the manifold eliminating the need for tubing. The enclosure provides environmental protection for the electrical components and four mounting holes for structural attachment. An electrical connector provides for the electrical interface to the PPU.

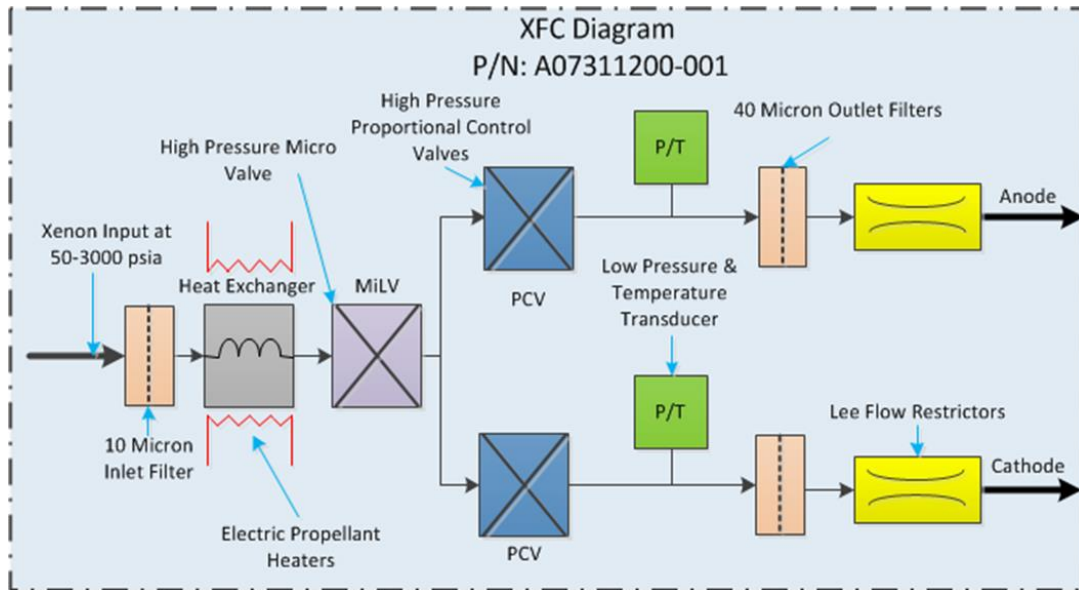

Figure 12. XFC Diagram

Propellant enters the XFC through an inlet tube equipped with an integral 10 micron etched disc filter. Flow then passes through an electric heat exchanger that is only required for extreme off-nominal operation. Flow from the heat exchanger passes through a micro latch valve that, when latched closed, provides the first interrupt against internal leakage. When latched open, flow from the micro latch valve splits into an anode and cathode branches. Both branches are identical except for their flow restrictors. Each branch contains a proportional flow control valve (PFCV), a 100kRad tolerant pressure and temperature transducer, an integrated 40 micron outlet filter/flow restrictor. Flow is controlled by modulating the PFCV to regulate pressure upstream of the flow restrictor. When unpowered, the normally-closed PFCV closes and seals, providing a second interrupt against internal leakage.

Inlet pressure is regulated by the spacecraft to a nominal 40 psia. Under off-nominal conditions, inlet pressure can be as high as 3,000 psia. For this reason, the XFC is rated for a maximum design pressure of 3,000 psia up to the inlet of the pressure control valve with proof pressure of 4,500 psia.

The XFC provides a flow rate of 8 to 23 mg/second of xenon with the ability to set the cathode to anode flow split through independent control of the anode and cathode proportional flow control valves. Cathode flow will be between 4 and 10 percent of the anode flow. The XFC design has less than 1.0×10^{-4} sccs of internal helium leakage and less than 1×10^{-6} sccs of external leakage at the high inlet pressure of 3,000 psia.

Each XFC will be calibrated to provide a flow rate measurement accuracy of $\pm 1.25\%$ at the inlet pressure of 40 psia and over a temperature range of 20°C to 45°C. The XFC can provide off-nominal operation at 3,000 psia in the event of a spacecraft regulator failure at de-rated accuracy and set-point capability.

The XFC design has already been qualified to vibration and shock levels in excess of the AEPS vibration levels of 8.1 grms for acceptance testing, 11.4 grms for qualification and shock levels of up to 2000 g's .

The XFC is specifically designed for the long durations required by future exploration missions. To that end, the internal components are designed for infinite fatigue life. Component fatigue life has been verified by analysis, except for the proportional actuators, which will be verified by third-party testing. The XFC is capable of a throughput greater than 1770 kg of xenon.

An EDU will be fabricated and will go through qualification-like testing in 2018. Full qualification testing will be performed on the first flight production unit in 2019.

VI. Early Integrated System Test

There is a very high level of coupling between the thruster, the discharge supply and the xenon flow controller. Integrating these elements together in an Early Integrated System Test (EIST) and characterizing this behavior is a valuable source of data and reduces the risk of late detection of potential design flaws during EDU testing. The EIST was performed at NASA GRC in Vacuum Facility 6 (VF-6). The units under test were of the AEPS DSU and xenon flow control electronics along with a NASA TDU-1 thruster and a VACCO XFCM. Figure 13 shows a diagram of the test setup.

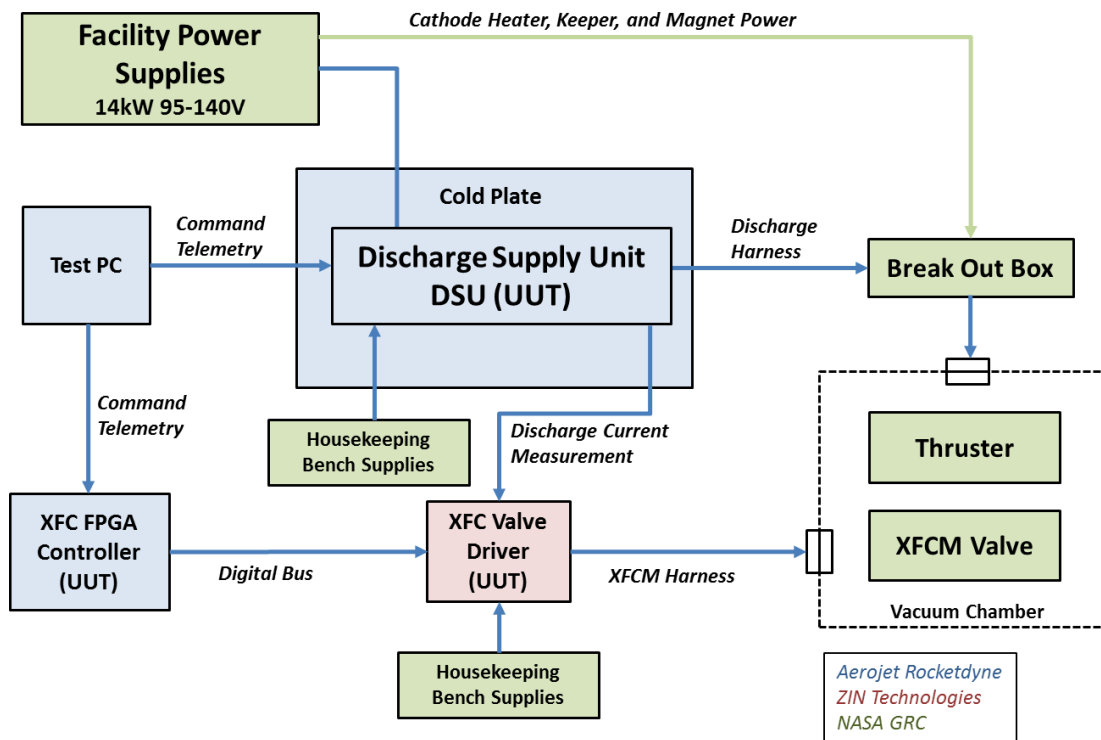

Figure 13. Test Setup

The DSU provides power to the TDU-1 thruster. The DSU consists of an input filter, discharge master controller, six power modules, and an output filter. The DSU tested was a breadboard design, mounted directly onto a cold plate, and did not include the flight-like mechanical structure (See Figure 14). It is built with commercial grade components, most of which have a flight equivalent part. Parts which did not have a flight equivalent were chosen because of schedule. The risk of not prototyping the exact flight circuit during the EIST was considered to be low. The code programmed into the DSU Field Programmable Gate Array (FPGA) is representative of the code planned for the flight unit design. The development of this code followed the Aerojet Rocketdyne FPGA development plan. The



Figure 14. Breadboard DSU

prototype DSU was designed to operate the TDU-1 over the full range of flight operating points.

The xenon flow control system for this test consisted of the VACCO XFCM valve, XFC valve driver and an XFC FPGA controller. The XFC valve driver card was produced by ZIN Technologies for this testing and is the basis for the flight version for the PPU. An FPGA was used to communicate with and command the XFCM and XFC valve driver card. The communication scheme and control algorithm developed in the FPGA were designed with the flight firmware/software limitations in mind. The algorithms will be eventually ported to the flight system.

The DSU and XFC system received commands and provide telemetry to a Windows PC with serial communication. The PC utilized commercial off-the-shelf software, providing manual control, scripting, and data recording capabilities through a custom designed user interface. The Test PC user interface included aspects of higher level spacecraft command functions and the PPU main control software. The user interface also recorded the direct digital information between the DSU and XFC which included both feedback and control loop outputs. This capability provided direct insight into how the DSU and XFC control systems functioned during testing.

Shown in Table 4 is a listing of key items that were under evaluation during the EIST with regard to the DSU and the XFC control system.

Table 4. Key Elements Evaluated During Early System Test

Evaluation Items	Description of evaluation
DSU efficiency	Determine the efficiency of the DSU when powering the thruster and compare to bench top testing with resistive/electric load.
DSU modular architecture	Evaluate if modular architecture can be used to take smaller power module circuits and add outputs the together to achieve a higher total power, voltage and current and meet component derating.
Output current	Evaluate ripple current, control resolution and ability to operate over full output current range. Also transient effects during various thruster startups.
Output voltage	Evaluate ripple voltage, control resolution and ability to operate over full output voltage range. Also transient effects during various thruster startups.
Anode/cathode flow control and closed loop discharge current control	Evaluate ability to control the flow of xenon gas with the new XFC driver card. Also show the anode flow can be adjusted based on a discharge current control loop with new digital control algorithm contained in FPGA. Also evaluated the flow systems ability to perform various thruster startups.
DSU thermal	Evaluate if DSU can run continuously without over-heating. Determine if components have proper thermal dissipation design.

The testing was accomplished over a three week period, with all primary and secondary objectives completed, including the items listed in Table 4. The initial test schedule allotted time for early troubleshooting. Though a few problems occurred during testing, the issues were resolved typically within a few hours. The successful completion of the initial primary and secondary test objectives in half the planned time allowed for completion of additional characterization tests.

These additional tests included running the thruster at a higher output current, which was approximately 25% higher output than the maximum current requirement. Another additional test was a thruster impedance measurement test. A new impedance measurement method and circuit was specifically designed for this test and the results were a significant improvement over previous attempts at measuring thruster impedance. These results will be factored into the electrical design and incorporated into models to improve PPU performance modeling with a thruster.

The team demonstrated DSU operation of the TDU thruster at the full power range required for a mission. The successful operation of the xenon flow control system testing marked the first time the TDU thruster was operated in a closed loop discharge current control mode. Design solutions to address the issues observed during the test are now in work and will be incorporated into the final design.

VII. Conclusion

The AEPS program has completed the first phase of the design process through the Preliminary Design Review and successfully completed an early integration system test demonstrating the required control and throttling capabilities of the thruster, PPU and XFC. The component teams have incorporated design improvements to the respective heritage/baseline designs to better meet the program and mission needs. The preliminary analysis has highlighted some design issues. Solutions to these issues are in progress and will be incorporated into the final component designs. Engineering Development Unit hardware manufacture is underway with extensive component testing and system level operation planned for 2018. The program is on track to complete the component and system qualification testing in 2019 as well as delivery of five flight EP strings.

VIII. Acknowledgments

The AEPS program team would like to thank the NASA Space Technology Mission Directorate for their continued support of the work discussed in this paper and all the AEPS reviewers, technical consultants and team members at Aerojet Rocketdyne and NASA who have contributed to the success of the program to date. Portions of the research described in this paper were carried out at the Jet Propulsion Laboratory, California Institute of Technology, under a contract with the National Aeronautics and Space Administration.

IX. References

¹ Free, J., "Architecture Status," NASA Advisory Council Human Exploration and Operations Committee Meeting, https://www.nasa.gov/sites/default/files/atoms/files/march_2017_nac_charts_architecturejmf_rev_3.pdf, [cited March 28, 2017].

² Cassady, J. et. al, "Next Steps In The Evolvable Path To Mars," IAC-15-D2,8-A5.4,8, *66th International Astronautical Congress*, Jerusalem, Israel, 12–16 October 2015

³ Advanced Electric Propulsion System EP String Requirements Document, IPS-STR-REQ-0001 July 20th 2017

⁴ Hofer, R. R., et al., "The 12.5 kW HERMeS Hall thruster for the Asteroid Redirect Robotic Mission," AIAA-2016-4825, 52nd AIAA/SAE/ASEE Joint Propulsion Conference, Salt Lake City, UT, July 25-27, 2016.

⁵ Mikelledes, I. Katz, I, Hofer, R., Goebel, D., de Grys, K. Mathers, A., "Magnetic Shielding of the Channel Walls in a Hall Plasma Accelerator," *Physics of Plasmas* 18, 33501 (2011).

⁶Herman, D. A., *et al.*, "The Ion Propulsion System for the Asteroid Redirect Robotic Mission," AIAA-2016-4824, 52nd AIAA/SAE/ASEE Joint Propulsion Conference, Salt Lake City, UT, July 25-27, 2016.

⁷ Santiago, W., et al, "High Input Voltage, Power Processing Unit Performance Demonstration," AIAA-2016-5033, 52nd AIAA/SAE/ASEE Joint Propulsion Conference, Salt Lake City, UT, July 25-27, 2016

⁸ Cardin, J. M., Cook, W., and Bhandari, R., "Qualification of an Advanced Xenon Flow Control Module," IEPC-2013-382, 33rd International Electric Propulsion Conference, Washington, DC, Oct. 6 - 10, 2013.

⁹ "Thruster and Power Processing Unit Development for an Advanced Electric Propulsion System Acquisition," Solicitation Number: NNC15ZCH014R, https://www.fbo.gov/index?s=opportunity&mode=form&id=8f06bbacbbd8c3d2d6c1108d9b0c70ef&tab=core&_cview=1,

¹⁰ Stanley, S., Chew, G., Rapetti, R., Tofil, T., Herman, D., Allen, M., Jackson, J., and Myers, R. "Development of a 13 kW Hall Thruster Propulsion System Performance Model for AEPS", 53rd AIAA/SAE/ASEE Joint Propulsion Conference, 2017.

¹¹ Hofer, R. R., Kamhawi, H., Mikellides, I., Herman, D., Polk, J., Huang, W., Yim, J., Myers, J., and Shastry, R., "Design Methodology and Scaling of the 12.5 kW HERMeS Hall Thruster for the Solar Electric Propulsion Technology Demonstration Mission," Presented at the 62nd JANNAP Propulsion Meeting, JANNAP-2015-3946, Nashville, TN, June 1-5, 2015.

¹² Kamhawi, H., Huang, W., Haag, T., Shastry, R., Thomas, R., Yim, J., Herman, D., Williams, G., Myers, J., Hofer, R., Mikellides, I., Sekerak, M., and Polk, J., "Performance and Facility Background Pressure Characterization Tests of NASA's 12.5-kW Hall Effect Rocket with Magnetic Shielding Thruster," Presented at the 34th International Electric Propulsion Conference, IEPC-2015-007, Kobe, Japan, July 4-10, 2015.

¹³ Williams, G. J., Gilland, J. H., Peterson, P. Y., Kamhawi, H., Huang, W., Ahern, D. W., Yim, J., Herman, D. A., Hofer, R. R., and Sekerak, M., "Wear Testing of the HERMeS Thruster," AIAA-2016-5025, July 2016.

¹⁴ Kamhawi, H., Huang, W., Haag, T., Yim, J., Herman, D., Peterson, P. Y., Williams, G., Gilland, J., Hofer, R., and Mikellides, I., "Performance, Facility Pressure Effects, and Stability Characterization Tests of NASA's Hall Effect Rocket with Magnetic Shielding Thruster," AIAA-2016-4826, July 2016.
