

68th International Astronautical Congress (IAC), Adelaide, Australia, 25-29 September 2017. Copyright ©2017 by the International Astronautical Federation (IAF). All rights reserved. One or more authors of this work are employees of the government of the United States, which may preclude the work from being subject to copyright in the United States, in which even no copyright is asserted in that country.

IAC-17-D3.3.1

Overview of NASA Technology Development for In-Situ Resource Utilization (ISRU)

Diane L. Linne^{a*}, Gerald B. Sanders^b, Stanley O. Starr^c, David J. Eisenman^d, Nantel H. Suzuki^e, Molly S. Anderson^f, Terrence F. O'Malley^g, Koorosh R. Araghi^b

^a *Propulsion Division, NASA Glenn Research Center, 21000 Brookpark Road, Cleveland, OH, U.S.A. 44135, diane.l.linne@nasa.gov*

^b *Propulsion and Power Division, NASA Johnson Space Center, 2101 NASA Rd 1, Houston, TX, U.S.A. 77058, gerald.b.sanders@nasa.gov, koorosh.r.araghi@nasa.gov*

^c *Exploration Research and Technology, NASA Kennedy Space Center, John F. Kennedy Space Center, Kennedy Space Center, FL, U.S.A. 32899, Stanley.o.starr@nasa.gov*

^d *Human/Robotic Mission Systems Development Office, NASA Jet Propulsion Laboratory, 4800 Oak Grove Drive, Pasadena, CA, U.S.A. 91109, david.j.eisenman@jpl.nasa.gov*

^e *Advanced Exploration Systems Division, NASA Headquarters, 300 E Street SW, Washington, DC, U.S.A. 20546, nantel.h.suzuki@nasa.gov*

^f *Crew and Thermal System Division, NASA Johnson Space Center, 2101 NASA Rd 1, Houston, TX, U.S.A. 77058, molly.s.anderson@nasa.gov*

^g *Exploration Systems Project Office, NASA Glenn Research Center, 21000 Brookpark Road, Cleveland, OH, U.S.A. 44135, tfomalley@nasa.gov*

* Corresponding Author

Abstract

In-Situ Resource Utilization (ISRU) encompasses a broad range of systems that enable the production and use of extraterrestrial resources in support of future exploration missions. It has the potential to greatly reduce the dependency on resources transported from Earth (e.g., propellants, life support consumables), thereby significantly improving the ability to conduct future missions. Recognizing the critical importance of ISRU for the future, NASA is currently conducting technology development projects in two of its four mission directorates. The Advanced Exploration Systems Division in the Agency's Human Exploration and Operations Mission Directorate has initiated a new project for ISRU Technology focused on component, subsystem, and system maturation in the areas of water/volatiles resource acquisition, and water/volatiles and atmospheric processing into propellants and other consumable products. The Space Technology Mission Directorate is supporting development of ISRU component technologies in the areas of Mars atmosphere acquisition, including dust management, and oxygen production from Mars atmosphere for propellant and life support consumables. Together, these two coordinated projects are working towards a common goal of demonstrating ISRU technology and systems in preparation for future flight applications.

Keywords: In-situ resource utilization, Exploration, Mars, Lunar, Propellants

Acronyms/Abbreviations

Advanced Exploration Systems (AES)
 Bi-Supported Cell (BSC)
 Human Exploration and Operations Mission Directorate (HEOMD)
 In-Situ resource utilization (ISRU)
 International Space Station (ISS)
 Mars In-Situ Propellant Production Precursor (MIP)
 Mars Oxygen In-situ Experiment (MOXIE)
 National Aeronautics and Space Administration (NASA)
 Precursor ISRU Lunar Oxygen Testbed (PILOT)
 Small Business Innovation Research (SBIR)
 Solid Oxide Electrolysis/Electrolyzer (SOE)
 Space Technology Mission Directorate (STMD)
 Technology Readiness Level (TRL)

1. Introduction

The National Aeronautics and Space Administration's (NASA) Journey to Mars: Pioneering Next Steps in Space Exploration [1], released in October of 2015, states that NASA is working toward the capability to work, operate, and sustainably live safely beyond Earth. To progress from our current "Earth-Reliant" approach to exploration and eventually become "Earth independent," we need to first identify resources in space and then learn to use and harvest them to minimize logistics from Earth, reduce costs, and enable sustainable and affordable space transportation and surface operations. NASA's Evolvable Mars Campaign called for crewed missions to cislunar space in the 2020's, and in the vicinity of Mars by the mid 2030's. The last detailed NASA mission architecture that was released to the public, the Mars Design Reference Architecture 5.0 [2,3], identified the production of

oxygen from Mars resources for Mars ascent propulsion as enabling for human exploration of Mars, and production of methane as enhancing. More recent studies by the Evolvable Mars Campaign team have assumed that ISRU is part of the architecture [4].

Recognizing the critical importance of ISRU for the future of exploration, NASA is currently conducting technology development projects in two of its four mission directorates. This paper provides an overview of these two projects, including some highlights of their current and future technology development activities.

2. What is *In-Situ Resource Utilization*?

In-Situ Resource Utilization involves any hardware or operation that harnesses and utilizes ‘in-situ’ resources to create products and services for robotic and human exploration. The primary objective is to collect and convert local resources into products that can reduce mission mass, cost, and/or risk of human exploration and lead to Earth independence. There are multiple steps required to produce an in-situ-derived product, and multiple products that are possible.

Resource Assessment (Prospecting) includes the assessment and mapping of physical, mineral, chemical, and water resources, terrain, geology, and environment. Prospecting can be accomplished on the ground or from orbit. Typically prospecting will occur in stages, with orbital assessment identifying broad areas of interest, and ground prospectors providing specifics on quantity, distribution, depth, etc.

Resource Acquisition includes excavation, drilling, extraction and collection of volatiles including water, atmosphere collection, and preparation and beneficiation of resources before processing.

Resource Processing/Consumable Production includes the extraction and processing of resources into products with immediate use or as feedstock for construction and manufacturing. Primary products of interest include large-quantity mission consumables such as propellants, life support consumables, and fuel cell reactants.

In-Situ Manufacturing includes the production of replacement parts, complex products, machines, and integrated systems from feedstock derived from one or more processed resources. This ISRU category differs from advanced space manufacturing technology development by specifically focusing on use of in-situ materials for manufacturing, as opposed to feedstock supplied from Earth.

In-Situ Construction includes activities often thought of as civil engineering, including infrastructure emplacement, and structures built using materials produced from in-situ resources. Potential products may include radiation shields, landing/launch pads, roads, berms, and habitats.

In-Situ Energy includes the generation and storage of electrical, thermal, and chemical energy using in-situ derived resources and materials. Potential products may include solar arrays, thermal and energy storage, and chemical batteries.

Many other exploration systems are also required to enable ISRU. For example, mobility systems for delivery of raw resources to the ISRU plant and finished product to the consumer, power and thermal management systems to provide power and dissipate heat, and autonomy technology to enable autonomous operations over hundreds of days must all be integrated with the ISRU systems.

3. Why ISRU Technology Development is Needed Now

ISRU is a disruptive capability that enables more affordable exploration than today’s paradigm where all supplies are brought from Earth and allows more sustainable architectures to be developed. The availability of ISRU technologies can radically change the mission architecture, and be the sizing design driver for other complex systems already in development. For example, producing ascent propellants on the Mars surface can reduce the required landed mass by 75 percent, greatly alleviating the entry, descent, and landing challenge. A decision to use storable propellants for the Mars ascent vehicle would eliminate the possibility to produce 30 metric tons of propellant on the Mars surface and reduce the Earth launch requirements by 300 metric tons. Therefore, it is imperative that ISRU system technologies are demonstrated early, so that mission planners will have the confidence to include in-situ capabilities in the baseline mission design.

Without assurance that ISRU capabilities will be available for the first mission, other system designs may not be tailored to take full advantage of ISRU technologies, resulting in more complex or heavier designs. Examples include a more complex closed-loop life support system if resupply with ISRU water cannot be assumed, or a heavy, built-in habitat radiation shield if a water- or regolith-based shield cannot be added after habitat delivery to the surface. Other system designers may make decisions that reduce the benefit of incorporating ISRU into the system, resulting in a larger or more inefficient ISRU system. For example, a non-continuous power source such as solar power would increase the required production rate and peak power of an ISRU plant, thus increasing its size and complexity due to hundreds of start-stop cycles. However, a continuous power source, such as nuclear or solar power with storage, would allow an ISRU plant to operate continuously, thus minimizing its size, complexity, and power draw. These are only a few examples of how the inclusion of ISRU has ripple effects across many other exploration elements.

ISRU is also a new capability that has never before been demonstrated in space or on another extraterrestrial body. Every other exploration system or element, such as power, propulsion, habitats, landers, life support, rovers, etc., have some form of flight heritage, although almost all still need technology development to achieve the objectives of future missions. This is another critical reason why ISRU technology development, leading to a flight demonstration mission, needs to be started now, so that flight demonstration results can be obtained early enough to ensure that lessons learned can be incorporated into the final design.

4. ISRU State-of-the-Art

Significant work has been performed over the last several decades to demonstrate the feasibility of ISRU concepts and to develop components and technologies. For Mars atmosphere collection and compression, concepts such as cryofreezers, temperature-swing sorption pumps, mechanical compressors, and ionic liquids have been proposed and tested in the laboratory at scales much smaller than human mission needs. Many concepts for lunar regolith excavation have been built and demonstrated in labs and outdoor ‘sandboxes’ and outdoor test sites. Reactors to extract oxygen from lunar mineral oxides have been built and tested.

There has also been some development and testing performed at the subsystem and system level. For lunar ISRU, the Precursor ISRU Lunar Oxygen Testbed (PILOT) and ROxygen subsystems were tested at a remote site on Mauna Kea [5]. For Mars ISRU, a portable Mars oxygen production plant using solid oxide electrolysis technology was demonstrated at several conferences and labs around the country in the early 90’s [6] and an end-to-end Mars oxygen and methane production system using Sabatier/Water electrolysis technologies with oxygen liquefaction was tested in a 6-m diameter Mars environment simulation chamber in 2000 at the NASA Johnson Space Center (JSC) [7]. The Mars In-Situ Propellant Production Precursor (MIP) [8] was a small Mars flight experiment built for the Mars 01 mission that included a temperature-swing sorption bed for CO₂ acquisition and solid oxide electrolysis cell for oxygen production. Unfortunately, the MIP experiment was never flown when NASA’s Mars robotic exploration program was revised following the loss of the Mars Polar Lander in 1999 [9]. The Mars Oxygen ISRU Experiment (MOXIE) flight experiment, which will demonstrate the production of oxygen at about 1/200th of full human scale, is under development at the Massachusetts Institute of Technology (MIT) and the Jet Propulsion Laboratory (JPL) and is currently manifested on the Mars 2020 rover mission [10].

While much noteworthy technology work and some system level development and testing has been

performed in the past, significant work is needed to mature all of the ISRU technologies to:

- Develop and test much closer to full-scale for human mission needs;
- Demonstrate much longer operation durations;
- Validate performance under relevant environmental conditions;
- Demonstrate successful integration and operation between the many components and subsystems that comprise a complete ISRU system; and
- Realize the synergy between ISRU and other exploration elements such as propulsion, life support, power, mobility, thermal management, etc.

Many critical challenges still exist to determine the ‘right’ set of components and subsystems to enable the production of mission consumables from regolith and/or atmospheric resources at a variety of destinations. Significant testing is also still required to measure the performance and life that can be expected from ISRU systems operating in the actual environment.

5. ISRU Technology Project

While ISRU encompasses all the steps in the process and all the possible products, NASA’s Human Operations and Exploration Mission Directorate (HEOMD) and Space Technology Mission Directorate (STMD) have initiated projects that focus specifically on Resource Acquisition and Resource Processing / Consumable Production, as described in Section 2. The HEOMD Advanced Exploration Systems (AES) Division ISRU Technology Project’s scope is to develop the component, subsystem, and system technologies to enable production of mission consumables from either regolith or atmospheric resources at a variety of destinations. The STMD Game Changing Development program has proposed a project with an ISRU scope to develop advanced technologies to address critical gaps and provide these technologies for use in flight missions. Working together, the combined HEOMD and STMD objective is to advance ISRU system-level technology readiness to prepare for flight demonstrations. The initial focus is critical technology gap closure culminating with component testing in relevant environment, for a Technology Readiness Level (TRL) of 5 [11]. Interim project goals are to combine components into subsystems and test in a relevant environment for performance, operations, and life. The final project goals are to perform end-to-end ISRU system tests in relevant environment to bring the System to a TRL 6, and to conduct integrated ISRU-exploration element demonstrations in relevant environment. Figure 1 shows a top-level schedule showing the flow from component to subsystem to system development, as well as opportunities for

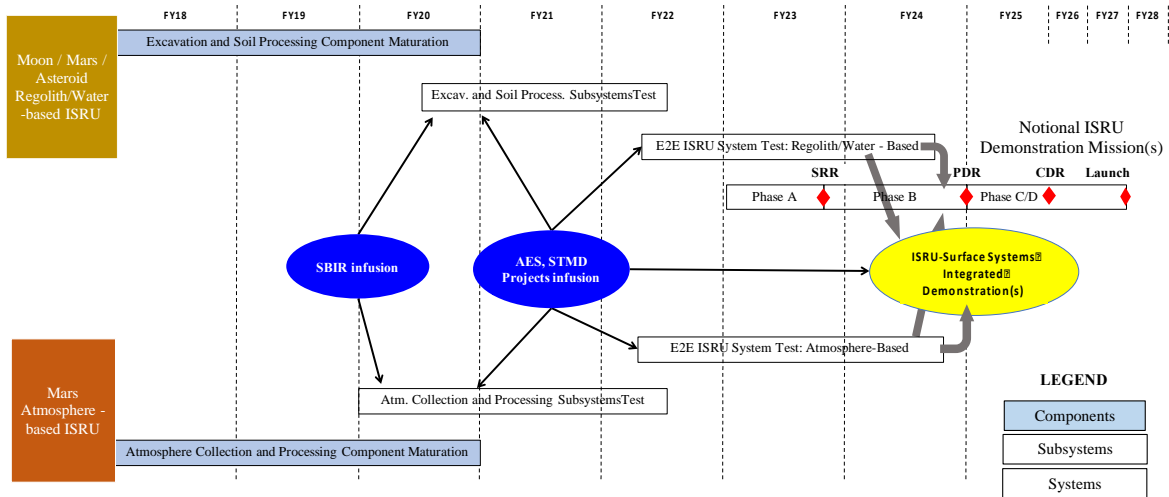

Figure 1. ISRU Technology Project top-level schedule.

technology infusion from other NASA projects and industry activities. Also included is a timeline for a notional demonstration mission, showing how the technology development plan will advance ISRU to TRL 6 prior to the preliminary design review for this notional

mission. Figure 2 is a pictorial representation of the work breakdown structure for the HEOMD ISRU Technology Project, and also shows the STMD programs that have some ISRU content.

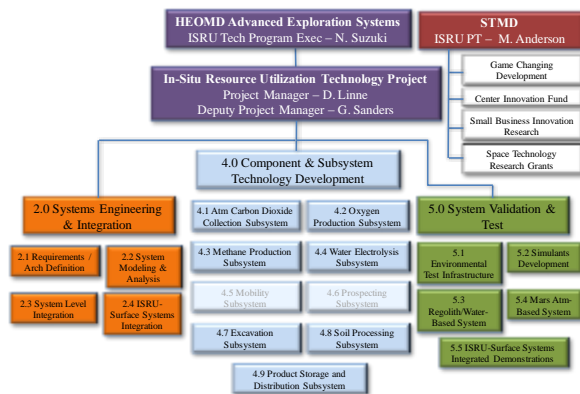

Figure 2. Work breakdown structure for AES ISRU Technology Project and STMD programs with ISRU content. (Lightened 4.0 boxes indicate no direct funds from AES ISRU project.)

Before the start of the ISRU Technology Project, both ‘official’ mission plans and proposed working mission architectures were assessed to identify requirements for ISRU systems on the Moon and Mars in terms of production rates, operating times, and environmental conditions [12]. In addition, a detailed assessment was made of the technologies, processes, subsystems, and systems required to make oxygen, oxygen and methane, and extract water from extraterrestrial soils to understand the state-of-the-art, options, and scope of the development effort to achieve TRL 6 for one or more ISRU systems. Figure 3 provides an example of one subsystem being developed to show the definition of components and technology options associated with the subsystem. To collect the Mars atmosphere, separate the carbon dioxide, and compress it for downstream processing, three elements are required: dust filtration /

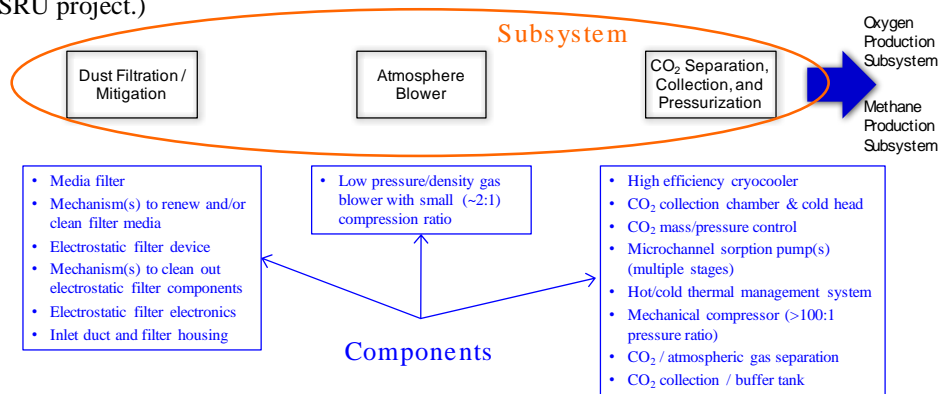

Figure 3. Example of component and subsystem definition for Atmosphere Carbon Dioxide Collection Subsystem.

mitigation, a blower to provide a fresh supply of atmosphere, and some type of separation and pressurization capability. Each of these elements may have several components, such as a media filter, filter housing, and cleaning mechanism for the dust mitigation element. The possible components are listed below each element, but it is important to note that many of the components listed are alternative technology options and not all of the components listed are needed for a given element.

Figure 4 depicts several system options that can be built by integrating the individual subsystems, depending on the desired final product and targeted resource. The following subsections highlight a few of the elements that are currently being developed and tested.

5.1 Dust filtration and Mitigation

Because Mars atmospheric conditions can vary due to wind, dust devils, and dust storms, dust filtration systems must be able to remove dust suspended in the atmosphere under a wide array of dust conditions to prevent damage to downstream components. Two types of filtration technology are being investigated: a scroll media filter and an electrostatic precipitator. A scroll filter system is based on a design of a filter system developed for life support systems to clean particulates out of spacecraft cabin air. The filter provides long filter life through multiple changes of the filter media inside the flow volume through a motorized media scrolling mechanism (Fig. 5). These filters will be tested in the Mars Flow

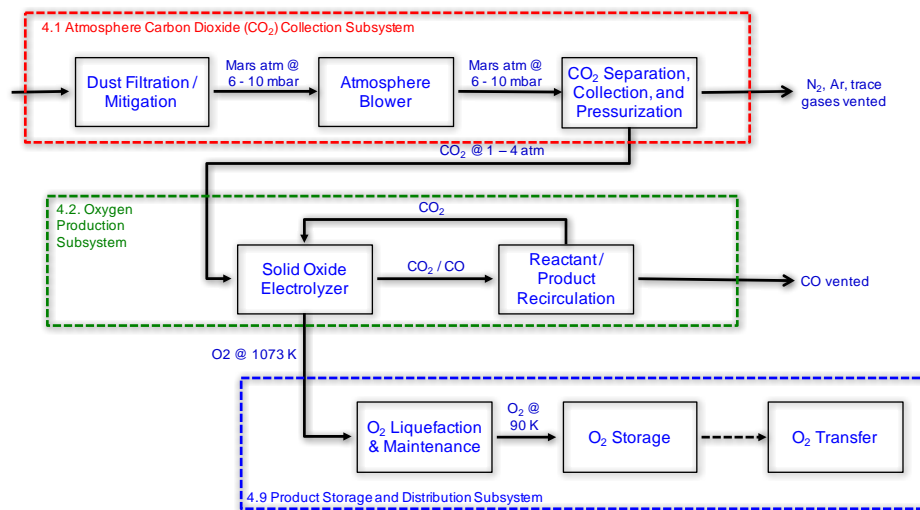

Figure 4a. Oxygen production from atmosphere integrated system (solid oxide electrolysis option).

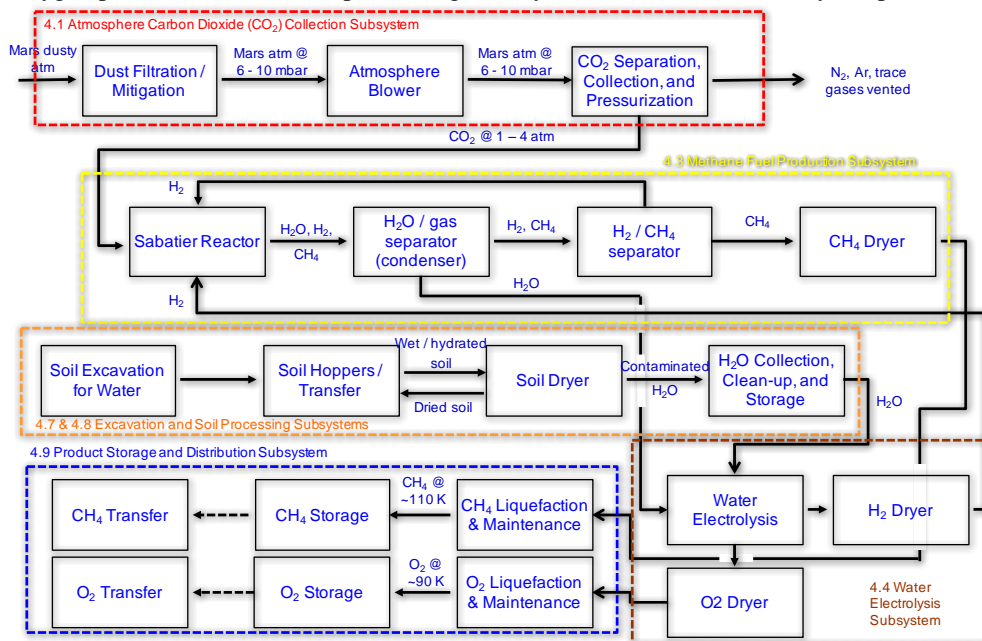

Figure 4b. Oxygen and methane production from atmosphere and soil water integrated system.

Loop facility at the NASA Glenn Research Center. This facility is a sealed recirculating flow loop with a 15-cm internal diameter. Axial fans and a vacuum pump provide flow induction and low pressures; it can be filled with alternate gases such as carbon dioxide to better simulate the Martian atmosphere. An integrated particle dispenser introduces many types of solid granular particles into the flow stream.

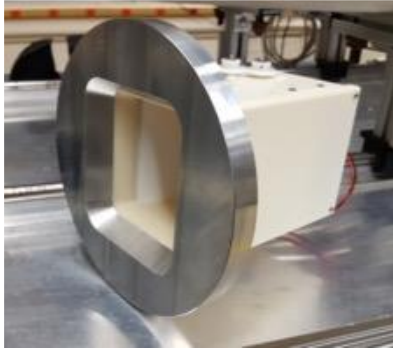

Figure 5. New Mars scroll filter system prototype.

Electrostatic precipitators use a high voltage corona discharge to charge aerosolized particles. The particles are deposited on collector electrodes as a result of electrostatic forces. Electrostatic precipitators are particularly effective for removing very small dust particles. Fundamental tests are being conducted on single-tube and honeycomb designs at the NASA Kennedy Space Center (KSC) to determine the effects of length, diameter, inlet velocity, and applied voltage on dust removal efficiency.

Other filtration techniques, such as cyclone separators and further work on media and electrostatic filtration, are being performed in Small Business Innovation Research (SBIR) contracts and other projects such as MOXIE. It is expected that more than one filtration technique may be required to completely remove dust from incoming Mars atmosphere gas flows.

5.2 Carbon Dioxide Collection, Separation, and Pressurization

The atmosphere of Mars is predominantly carbon dioxide (95.5 percent), with nitrogen, argon, and trace gases comprising the remaining portion. Because downstream processing components will be smaller and more efficient as operating pressure increases, it is beneficial to pressurize the CO₂ from the low Mars pressure (690 to 925 Pa), and to separate it from the other atmospheric gases. The ISRU Technology project is currently considering three primary options for this task, two of which are being worked this year and discussed here.

A cryofreezer operates by freezing the carbon dioxide out of a flowing stream of Mars atmosphere onto a cold head. Once the cold head is covered with frozen CO₂ to

the desired thickness, the chamber surrounding the cold head is sealed and allowed to warm up, thus melting and then vaporizing the CO₂, resulting in a chamber of high-pressure CO₂ that can be provided to the oxygen or fuel processing subsystems. Because CO₂ freezing efficiency declines as the thickness of frozen CO₂ on the cold head increases, and because the required collection rate of CO₂ is significantly higher than past design and experimental work [13,14], computational fluid dynamics analysis is being applied to various cold head designs to identify the patterns that have the best combination of high surface area and well-distributed gas flow, and preliminary freezing tests are being conducted to measure actual CO₂ accumulation (Fig. 6).

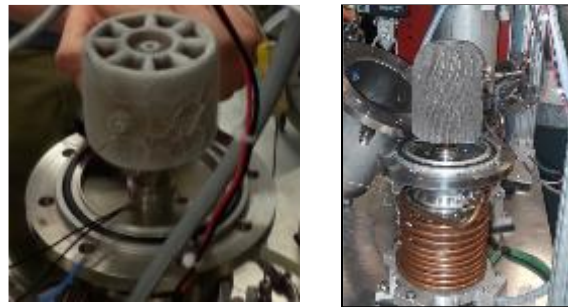

Figure 6. Two possible cold head designs being evaluated for CO₂ collection: (left) 'ferris wheel' design with frozen CO₂ after testing; (right) 'swirl head' mounted in chamber before testing.

A second option for CO₂ collection is a temperature swing adsorption pump. In this device, the Mars atmosphere is pushed through a sorbent material that preferentially adsorbs carbon dioxide at low temperatures. Once the adsorbent material is saturated, the material is heated to release the carbon dioxide at higher pressure. Because the mass of CO₂ adsorbed is small compared to the mass of the adsorbent (typically measured as grams of CO₂ per kilogram of adsorbent), initial concepts for long, overnight adsorption times resulted in large adsorption beds, leading to large thermal mass and poor performance due to prohibitive flow restrictions. In the late 1990's and early 2000's, the Pacific Northwest National Laboratory investigated methods to greatly reduce the size of the sorption pump by thermally cycling over a matter of minutes instead of hours [15,16]. A rapid adsorption/desorption cycle keeps the size of the sorption pump manageable, but requires a method to rapidly heat and cool the bed. As part of the ISRU Technology project, multiple thermal and fluid analyses are being applied to investigate the best combination of cycle time, number of stages, adsorption/desorption temperatures, sorption material, and stage size.

5.3 Solid Oxide Electrolysis (SOE)

One leading option for extracting oxygen from the Mars carbon dioxide is to use a solid oxide electrolyzer, which removes one oxygen atom from the CO₂ molecule, ionizes it, and pulls it through a solid electrolyte by applying an electrical potential across the cell. The rate at which oxygen is produced can be increased by increasing the active area per cell at applied voltages, adding more cells to a stack, and/or increasing the number of stacks used in a subsystem. Challenges for this technology include methods to manifold large stacks to distribute the CO₂ reactant and collect the O₂ product, seals that survive operating temperatures of 750 °C or higher, seals and materials to support temperature cycling, and careful selection of electrode and interconnect materials to prevent oxidation and delamination.

Within the ISRU Technology project, an assessment of the state-of-the-art is being performed this year to examine past and current development efforts in dry CO₂ SOE, and to identify key enablers and critical technology gaps for achieving scale-up, stable performance, and long life. Differences in fabrication methods, reliability, scalability, thermal cycling, thermal ramp rates, thermal gradients among the ceramic layers, operating pressure, stack sealing, and longevity are also being evaluated. Past and on-going SOE stack development activities being evaluated include two different designs developed and tested by Paragon Space Development Corporation under SBIR contracts, the SOE for the MOXIE flight experiment under development by Ceramatec, and an in-house NASA design developed under a NASA STMD program. Figure 7a shows a stack built by Ceramatec for the MOXIE flight experiment [10,17,18]. This design employs metal manifold plates between each ceramic electrolyte cell layer, with an outside compression force and glass seal to maintain a gas seal across all the layers.



Figure 7a. 10-cell SOE stack built for MOXIE (Ceramatec) in test stand.

In contrast, Fig. 7b depicts the all-ceramic bi-supported cell (BSC) design being developed at NASA GRC which utilizes an open-structure component on both sides of each electrolyte cell to act as gas channels and increase the electrode surface area [19]. For this design, inlet and outlet gases are delivered by ceramic manifolds that need to be sealed along the sides of the stacks. Recent

structural and thermal modelling of a small BSC stack has led to new designs for the manifolds to increase structural strength and improve gas distribution through the stack. These new manifold designs are being 3D printed out of zirconia oxide to match the thermal expansion coefficient of the electrolyte, and will be tested later this year for fluid and structural performance.

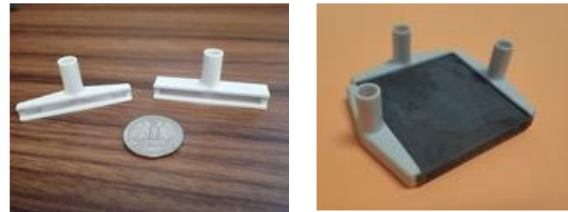

Figure 7b. (left) 3D-printed zirconia oxide manifold designs for GRC bi-supported SOE and (right) new manifolds loosely-fit to 3-cell BSC stack.

5.4 Sabatier Reactors

Sabatier reactors are being matured to produce methane from carbon dioxide and hydrogen. The hydrogen is derived from the electrolysis of soil-derived water, and the carbon dioxide is derived from the Mars atmosphere. A Sabatier system has been in use on the International Space Station (ISS) for some years so there is a high level of confidence in the technology, but ISRU methane production requirements are much larger than the current ISS reactors. These reactors are exothermic catalyst-based systems that require thermal and flow management and post-reactor gas separation. The ISRU Technology project is working challenges related to scaling up the reactor size, proper start-up and shutdown sequences, and the health and lifetime of the catalyst beads.

5.5 Water Extraction from Regolith

The AES ISRU Technology project is currently working to evaluate and develop several technologies to extract water from a variety of water-bearing extraterrestrial soils, including near-surface granular and hard hydrated soils, and subsurface ice at Mars, as well as frozen icy soils in the near permanently shadowed regions at the lunar poles. This research includes both the excavation of the raw resource and the extraction of the water. For extraction of water, three different options are under investigation: closed and open processors for near-surface granular and hard hydrated soils, and subsurface drilling and direct water extraction from deep ice deposits.

A closed processor receives water-containing soil in either a batch mode or semi-continuously, then applies energy to liberate the water. Terrestrial screw conveyor soil dryers are being investigated at NASA JSC for their

adaptability to use in lunar or Mars conditions. For this closed processor concept, an auger pushes the soil through a long tube that is externally heated to dry the soil. While terrestrial devices are merely used to dry the soil and therefore the evolved water is allowed to freely vent to the surroundings, modifications are required in an ISRU reactor to seal the auger dryer sufficiently so that the evolved water vapor can be captured and directed to a condenser or other collection device. Tests are being conducted to evaluate whether the soil itself can provide a sufficient seal against the near-vacuum environment on Mars and the Moon [20] (Fig. 8). While the screw conveyor soil dryer concept utilizes resistive heaters to warm the soil, other types of energy can be considered. For example, the NASA Marshall Space Flight Center examined heating lunar icy soils with microwave energy to release water in an enclosed vessel, and currently NASA JPL is investigating a similarly closed reactor where microwaves are directed at the soil to achieve water release.

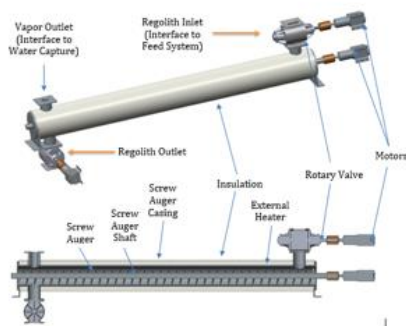

Figure 8. Screw conveyor soil dryer concept.

A second approach to extracting water from water-bound or hydrated soils on Mars is to use the Mars atmosphere as a sweep gas in an ‘open-air’ process that will continually harvest the released water as the rover/excavator roams the surface. While this process may lose some of the evolved water, it eliminates the need for reusable, high-temperature, dusty seals, and provides heat at the granular level to reduce long heating times. Hardware being tested at NASA GRC uses a transverse bucket wheel to deposit thin layers of soil on a vibrating, tilted, heated tray [20] (Fig. 9). The soil is quickly heated as it travels down the tray; evolved water vapor is swept into a condenser for collection. Preliminary tests with a hydrated salt (Borax) mixed into a generic simulant indicate that an average of 51 percent of the available water in the hydrated simulant was captured in the condenser. Modelling and testing continue such that the key parameters affecting the results can be understood in order to improve the efficiency of the design.

To extract water from potentially nearly-pure ice deposits at some depth below the surface, several

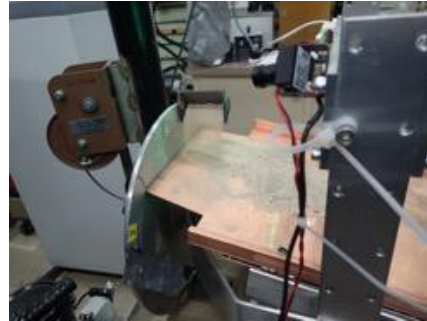

Figure 9. ‘Open-air’ soil processor showing transverse bucket wheel depositing soil on heated tray (cover and fans to direct evolved water to condenser removed for clarity).

concepts to extract the water directly without excavating the raw resource have been proposed. One terrestrial concept being evaluated for applicability to Mars is a Rodriguez Well (Rodwell) [21]. In a Rodwell, access to the ice deposit is created by drilling a shaft through the overburden and into the top of the ice sheet. Some form of heat is used, such as a heater or hot water pumped from the surface, to begin melting the ice into a pool of liquid water which can then be pumped out with a simple water pump. One key challenge of a Rodwell is to balance the rate of water extraction with the heat energy input. Other challenges with applying this concept to the surface of Mars include uncertainties in the subsurface profile and properties of the overburden layer and ice body, maintaining water in the liquid state at very low atmospheric pressures, and autonomous operations of the drilling and water extraction processes. Initial analysis performed at NASA JSC using a model validated for Rodwell operation on Earth has provided bounds on the energy / water withdrawal balance (Fig. 10). Work continues to modify the terrestrial model [22] with appropriate extraterrestrial environmental factors in

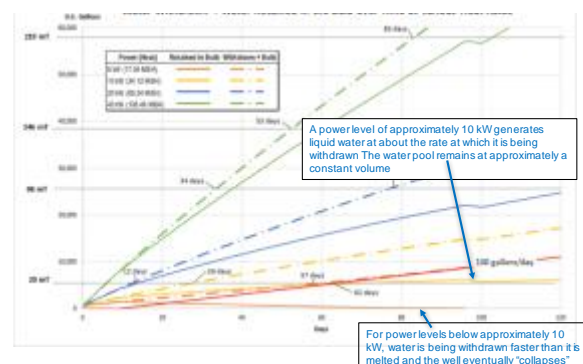

Figure 10. Preliminary analysis of water withdrawn and water retained in the bulb over time at various heat rates for 100 gallons per day water extraction from a Rodwell. (ref. 21 – used with permission)

preparation for fundamental tests of the concept in a lunar or Mars environment chamber.

5.6 Other ISRU Activities

Subsections 5.1 through 5.5 highlight just a few of the technology areas that are currently being worked under the NASA HEOMD and STMD ISRU projects. Additional work is being performed to develop or improve mechanical compressors for CO₂ acquisition, species separators, phase separators, water condensers, Sabatier reactors for production of methane fuel, excavators, and cryogenic liquefaction and storage. In addition, many ancillary components and technologies are needed to complete the ISRU system, such as heat exchangers and radiators, cryocoolers, insulation for the Mars environment, water electrolyzers, oxygen and methane regenerative dryers, autonomous controls and navigation, etc. Wrapping all of the components and subsystems together into an integrated system will also require constant attention to system operations and integration challenges to complete a system that can operate continuously for 500 days or longer without human intervention.

6. Summary

In-Situ Resource Utilization promises to change the way humans explore space, greatly reducing the reliance on Earth re-supply, reducing risk, and reducing cost of pushing the boundaries of human exploration. The National Aeronautics and Space Agency has started a focused development of ISRU components, subsystems, and integrated systems for the acquisition of resources and production into large quantities of propellant and life support consumables. Emphasis has been placed on testing early and often in terrestrial chambers that can simulate the lunar and Mars environment with appropriate extraterrestrial soil simulants, leading eventually to a potential flight demonstration mission to provide confidence for inclusion of ISRU into baseline exploration mission architectures.

Acknowledgements

The authors thank the larger community of NASA, University, and industry for many years of technology development that led to this technology maturation project. We would thank the extended project team, NASA and contractors, who are performing the challenging work we describe herein.

References

[1] "Journey to Mars: Pioneering Next Steps in Space Exploration," NASA, NP-2015-08-2018-HQ, October 2015 (available from <http://go.nasa.gov/1VHDXxg>).

- [2] Drake, B.G. (editor), "Human Exploration of Mars Design Reference Architecture 5.0," NASA-SP-2009-566, July 2009.
- [3] Drake, B.G., "Human Exploration of Mars Design Reference Architecture 5.0, Executive Summary," February 2009 (available from <http://ntrs.nasa.gov/archive/nasa/casi/ntrs.nasa.gov/20090012109.pdf>).
- [4] Polsgrove, T.P., Thomas, H.D., Stephens, W., Collins, T., Rucker, M., Gernhardt, M., Zwack, M.R., and Dees, P.D., "Human Mars Ascent Vehicle Configuration and Performance Sensitivities," IEEE Aerospace Conference, Big Sky, Montana, U.S., March 2017.
- [5] Sanders, Gerald B., and Larson, William E., "Final Review of Analog Field Campaigns for ISRU Technology and Capability Maturation," Advances in Space Research, 2015.
- [6] NASA Lewis Research Center, The Power to Go Beyond, Cleveland, 1993.
- [7] Sanders, G. B., Trevathan, J.R., Kaplan, D.I., Peters, T.A., Baird, R.S., Cook, J.S., McClean, M., and Pauly, K., "Development of In-Situ Consumable Production (ISCP) for Mars Robotic and Human Exploration at the NASA Johnson Space Center," 001CES-168, 30th International Conference on Environmental Systems (CES), Toulouse, France, July 2000.
- [8] Kaplan, D., "The 2001 Mars In-situ-propellant-production Precursor (MIP) Flight Demonstration: Project Objectives and Qualification Test Results," AIAA-200-5145, September 2000.
- [9] "Report on the Loss of the Mars Polar Lander and Deep Space 2 Missions," JPL Special Review Board, JPL D-18709, March 2000.
- [10] Hecht, M., "The latest from MOXIE," Planetary & Terrestrial Mining Sciences Symposium (PTMSS), Canadian Institute of Mining Conference, Montreal, Canada, May 2017.
- [11] "NASA Systems Engineering Processes and Requirements, Appendix E," NPR 7123.1B, (available from https://nodis3.gsfc.nasa.gov/displayDir.cfm?Internal_ID=N_PR_7123_001B_&page_name=AppendixE).
- [12] Linne, D.L., Sanders, G.B., and Taminger, K.M., "Capability and Technology Performance Goals for the Next Step in Affordable Human Exploration of Space," AIAA 2015-1650, January 2015.
- [13] Travathan, Joseph, Payne, Kevin, and Clark, David, "Carbon Dioxide Collection and Purification System for Mars," AIAA Space 2001 Conference, August 2001.
- [14] Linne, D.L., Gaier, J.R., Zoekler, J.G., Kolacz, J.S., Wegeng, R.S., Rassat, S.D., and Clark, D.L., "Demonstration of Critical Systems for Propellant Production on Mars for Science and Exploration Missions," AIAA 2013-0587, January 2013.

- [15] Sanders, G.B., Peters, T.A., Wegeng, R.S., TeGrotenhuis, W.E., Rassat, S.D., Brooks, K.P., and Stenkamp, V., "Report on Development of Micro Chemical/Thermal Systems for Mars ISRU-Based Missions," AIAA 2001-0939, January 2001.
- [16] Brooks, K.P., Rassat, S.D., and TeGrotenhuis, W.E., "Development of a Microchannel *In Situ* Propellant Production System," PNNL-15456, September 2005.
- [17] Hartvigsen, J., Elwell, J., and Elangovan, S., "Thermodynamic Constraints in Operating a Solid Oxide Electrolysis Stack on Dry Carbon Dioxide Gathered from the Mars Atmosphere," 1st International Conference on Electrolysis, Copenhagen, June 2017.
- [18] Elwell, J., Hartvigsen, J., Elangovan, S., Larsen, D., Meaders, T., Clark, L., Mitchell, E., and Millet, B., "Development and Flight Qualification of a Solid Oxide CO₂ Electrolysis Stack for the Mars 2020 MOXIE Project," 1st International Conference on Electrolysis, Copenhagen, June 2017.
- [19] Green, R.D., Matter, P.H., Holt, C., Beachy, M., Gaydos, J., Farmer, S.C., and Setlock, J.A., "Development Status for a Combined Solid Oxide Co-Electrolyzer and Carbon Formation Reactor System for Oxygen Regeneration," AIAA 2016-5454, AIAA Space 2016, September 2016.
- [20] Linne, D., Kleinhenz, J., Trunek, A., Hoffman, S., and Collins, J., "Extraction of Volatiles from Regolith or Soil on Mars, the Moon, and Asteroids," Planetary & Terrestrial Mining Sciences Symposium (PTMSS), Canadian Institute of Mining Conference, Montreal, Canada, May 2017.
- [21] Hoffman, S., Andrews, A., Joosten, B.K., and Watts, K., "A Water Rich Mars Surface Mission Scenario," IEEE Aerospace Conference, Big Sky, Montana, U.S., March 2017.
- [22] Lunardini, Virgil J., and Rand, John, "Thermal Design of an Antarctic Water Well," Special Report 95-10, U.S. Army Corps of Engineers, Cold Regions Research & Engineering Laboratory, Marsh 1995.