

Reconfiguration of NASA GRC's Vacuum Facility 6 for Testing of Advanced Electric Propulsion System (AEPS) Hardware

IEPC-2017-028

Peter Peterson

Vantage Partners, LLC, Cleveland, OH, 44135

Hani Kamhawi, Wensheng Huang, John Yim, Tom Haag, Jonathan Mackey, Mike McVetta, Luke Sorrelle, Tom Tomsik, Ryan Gillagan, and Daniel Herman

NASA Glenn Research Center, Cleveland, OH, 44135

Presented at the 35th International Electric Propulsion Conference
Georgia Institute of Technology • Atlanta, Georgia • USA
October 8 – 12, 2016

Motivation

High-Power SEP Critical to NASA Exploration Vision

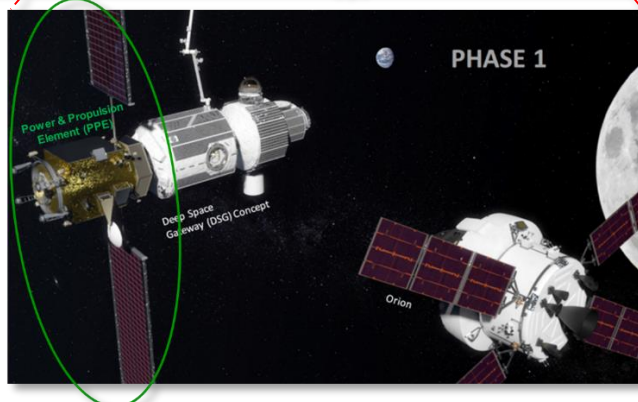
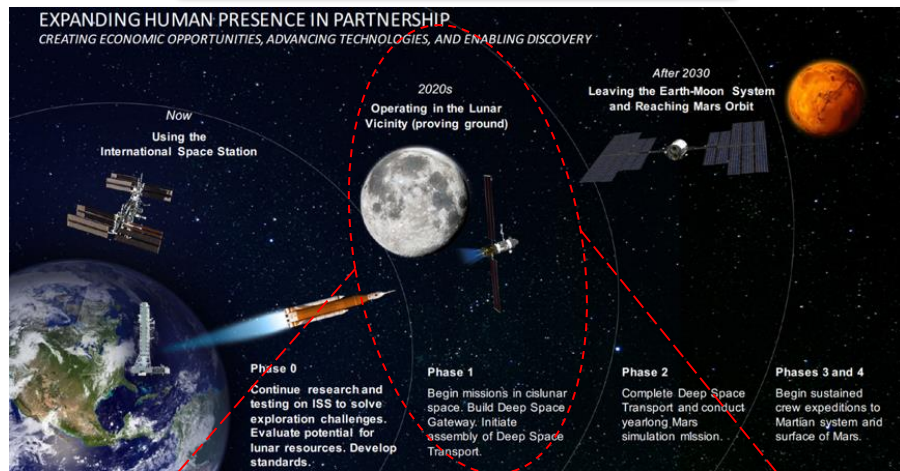

IEPC-2017-284: Dan Herman
"Overview of the Development and Mission Application of the Advanced Electric Propulsion System (AEPS)"

- As higher-powered Hall thrusters have become more widely planned in future NASA missions the need for highly capable vacuum facilities, and the availability of these facilities, becomes a potential risk to the schedule and NASA timeline.
 - To meet the HERMeS and the AEPS schedule it was determined that reconfiguring GRC's Vacuum Facility 6 (VF-6) was needed

The primary goal of this presentation, and associated paper, is to provide details on NASA recent efforts to provide additional high power EP vacuum facility for AEPS and other NASA projects

NASA GRC VF-6

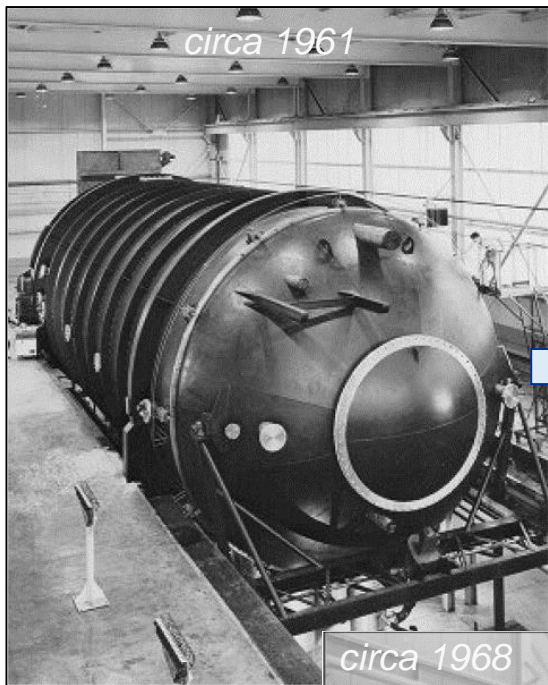

Patterson, M. J., and Sovey, J. S.
"History of Electric Propulsion at
NASA Glenn Research Center:
1956 to Present," *Journal of
Aerospace Engineering* Vol. 26, No.
2, 2013, pp. 300-316



VF-6 Upgrades & Reconfiguration

- The primary objective was to reproduce the testing capabilities that currently exist in NASA GRC Vacuum Facility 5 (VF-5)
 - Low sputtering yield shielding
 - High-power EP diagnostics
 - Thrust stand
 - Plasma plume probes
 - QCM (backsputter)
 - Ion gauges (pressure)
 - High-speed telemetry (stability)
 - Near thruster electrical configuration
 - Power and propellant subsystems
 - Data acquisition and telemetry sense lines

VF-6 Shielding & Pumping Speed Study

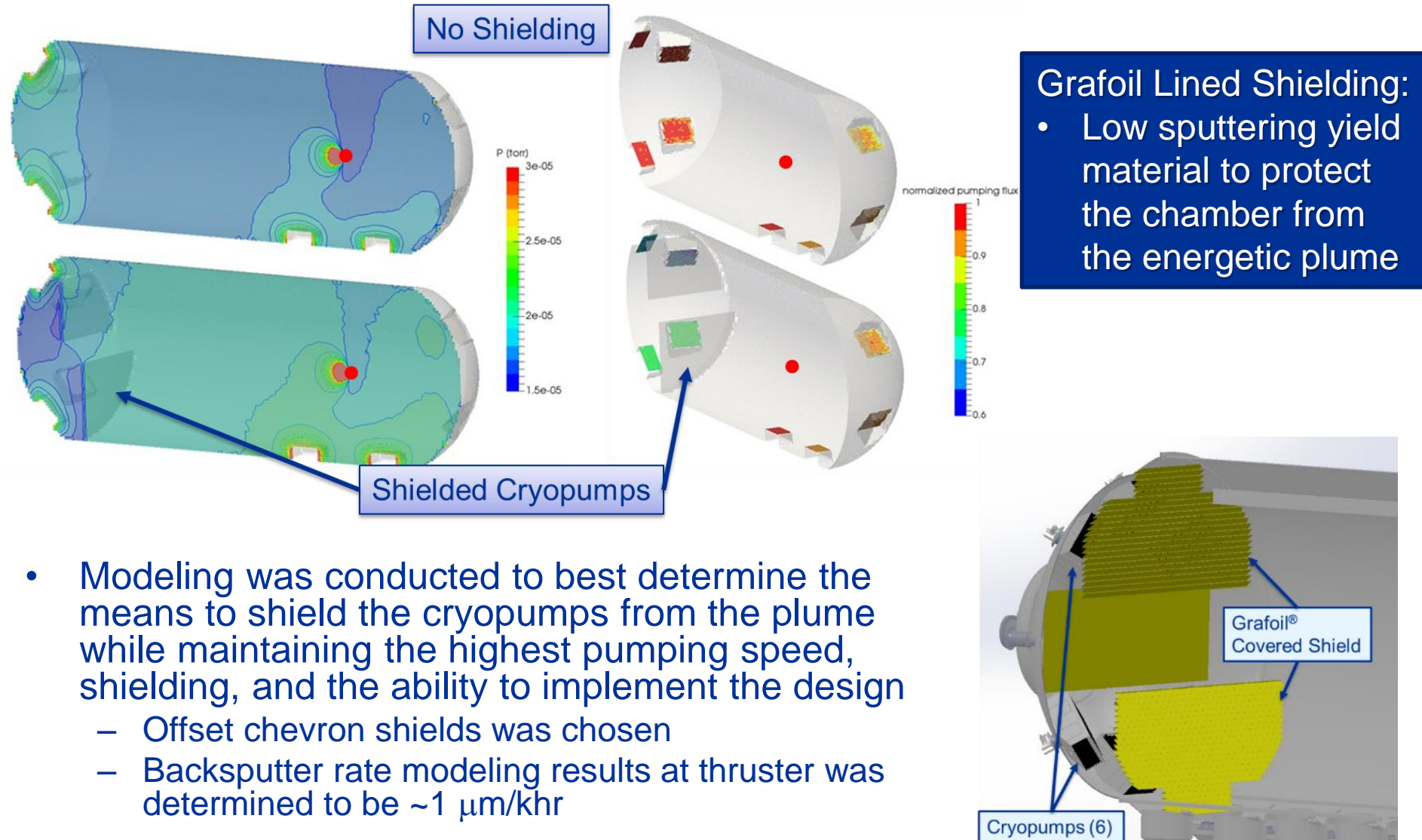

VF-6 Shielding Installation



Facility Electrical Configuration

Test-Like-You-Fly:

- All facility equipment, structures, and diagnostic equipment near the TDU are isolated from the thruster and plasma by floating and/or dielectric shielding
 - Reduce and/or eliminate low-resistance paths for e- besides plume
- The thruster are isolated from ground and monitored

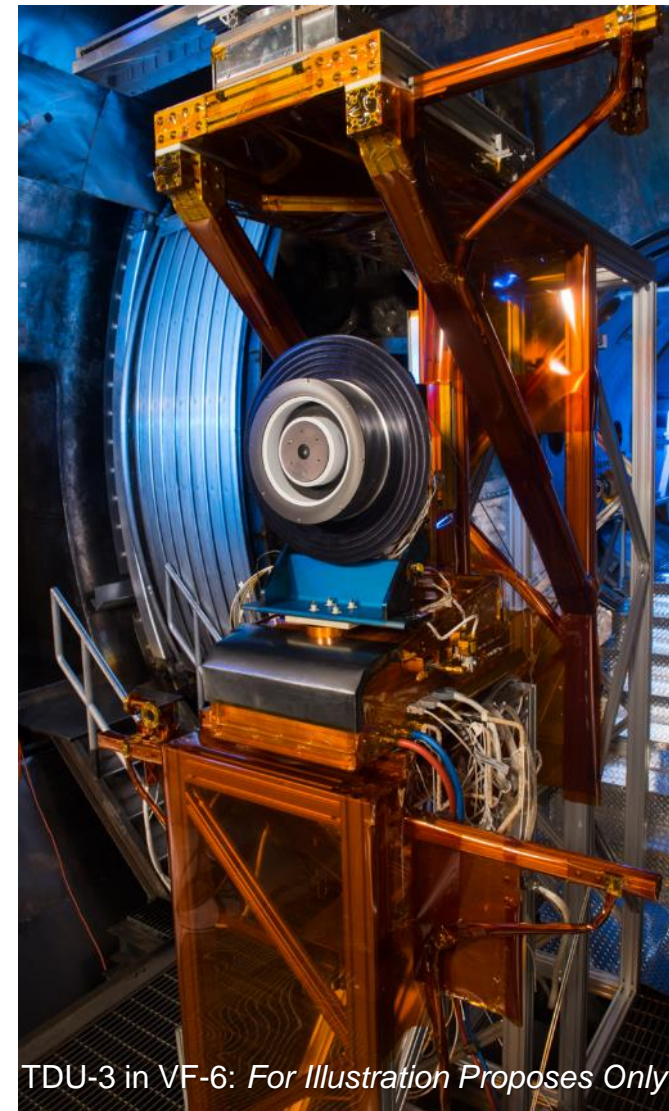

TDU-3 in VF-6: For Illustration Proposes Only

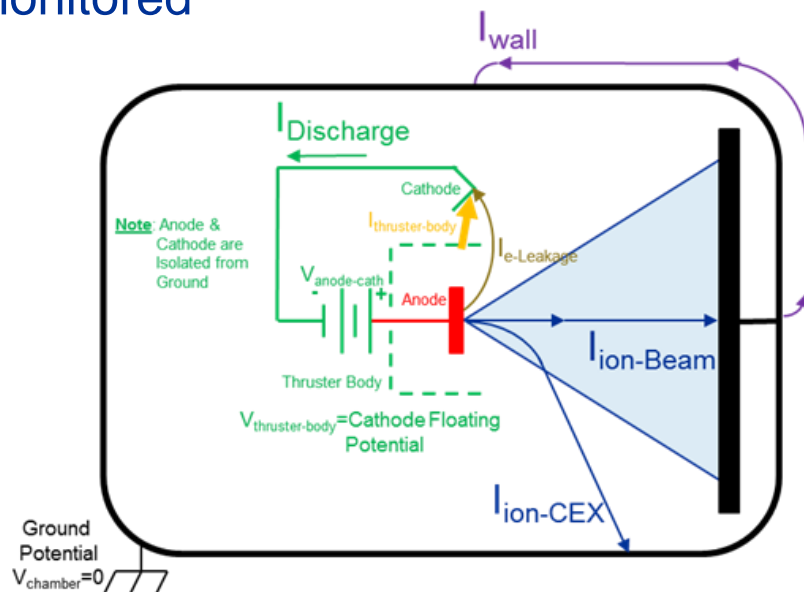

Diagnostics (Performance & Plume)

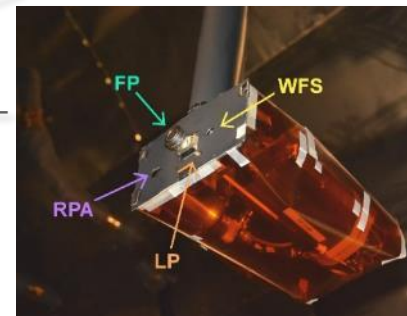
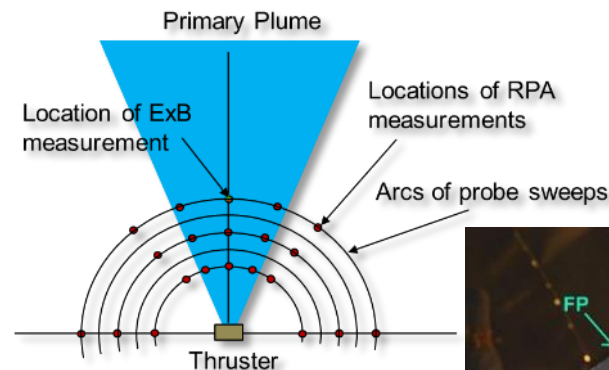
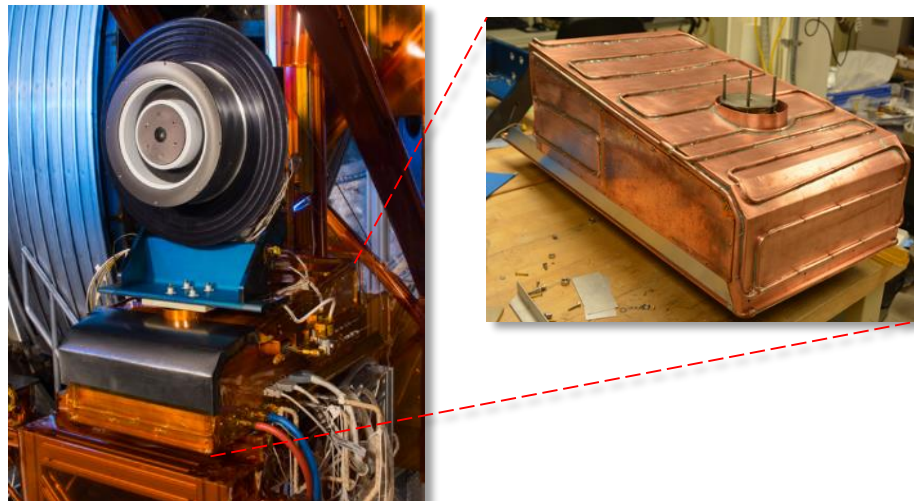

Thrust stand:

- Based on VF-5 high-power NASA GRC thrust stand
 - Successfully demonstrated precise thrust measurement for high power Hall thruster for over 16 years
 - Demonstrated thrust stand uncertainty of 0.8% 1σ (5.0 mN)
 - Demonstrated thrust measurement repeatability is 0.6% 1σ (3.3 mN)

Plasma probes:

- Based on the probe system developed and successfully demonstrated in VF-5
- Mounted in a package on radial-polar stages
 - Faraday probe (FP)
 - Retarding potential analyzer (RPA) data corrected with Langmuir probe (LP) data several radial positions
 - **ExB** probe (*Wien filter spectrometer*)
 - Inspection camera

Plasma Diagnostic Sweep

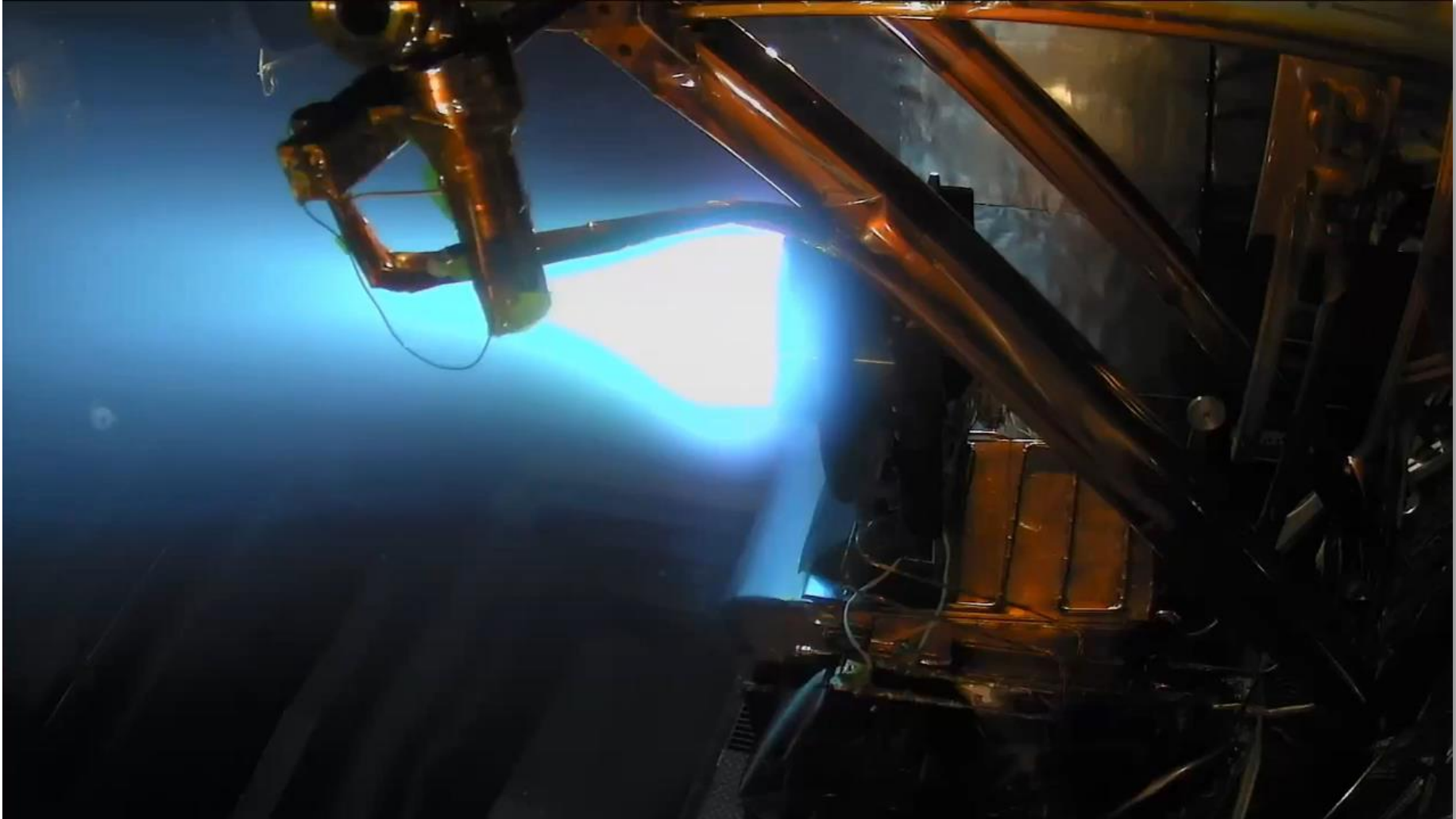

Diagnostics (Pressure & Backsputter)



- Ion Gauge
- QCM

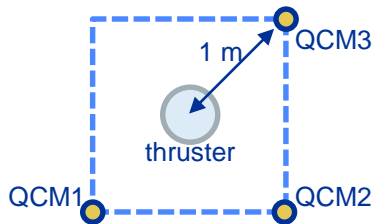

EP Ion Gauge Configuration

- Built-in plasma screen
- Calibrated on Xe
- Elbow
- Additional plasma screen

Ion gauge calibration data used to correct pressure post-test

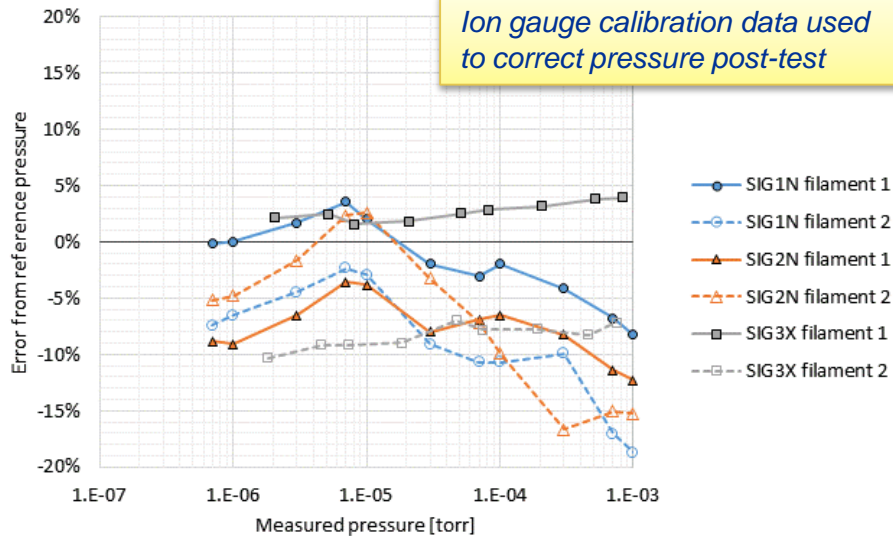

- Internal ion gauges
 - Three EP configured ion gauges installed near the thruster
 - 2 calibrated on air
 - 1 calibrated on xenon
 - One ion gauge pointed downstream towards the beam dump
 - Two facing radially outward from the thruster

- QCM
 - Three QCM installed at approximately 1 m from the center of the thruster
 - Facing towards the beam dump

Subsystems (Power & Telemetry)

HERMeS Power Console:

- Laboratory power supplies
- Both manually and automated control
 - DAQ interlocked
 - IVB sweeps are controlled by DAQ computer

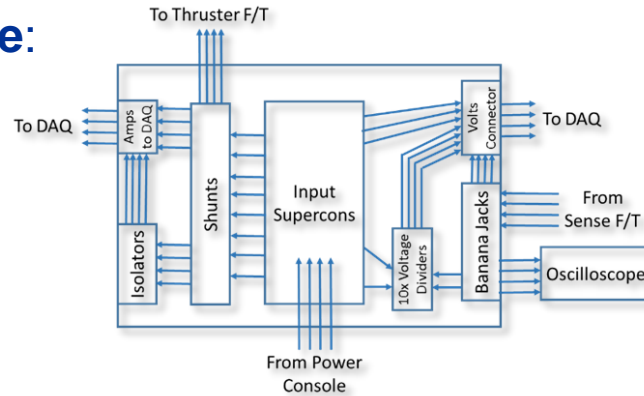

Break Out Box:

- Accepts laboratory power and PPU inputs
- Telemetry through connectors
- High voltage current sense with optical isolators
- Direct high-speed connections for oscilloscopes measurements
- Thruster telemetry calibrated at the thruster interface with a traceable high-precision digital multimeter

Data acquisition:

- Telemetry from BoB
- Oscilloscope recording
- XFS recording
- QCM data recording
- Power console control for IVB tests
- Failsafe interlocked

Subsystems (Xenon Feed System)

Laboratory xenon propellant feed system

- Two bottle setup for continuous operation
- In-situ flows calibration with calibrated Dry Cal
- Flows recorded by the DAQ
- Propellant flow manual set
- Meets NASA IPD

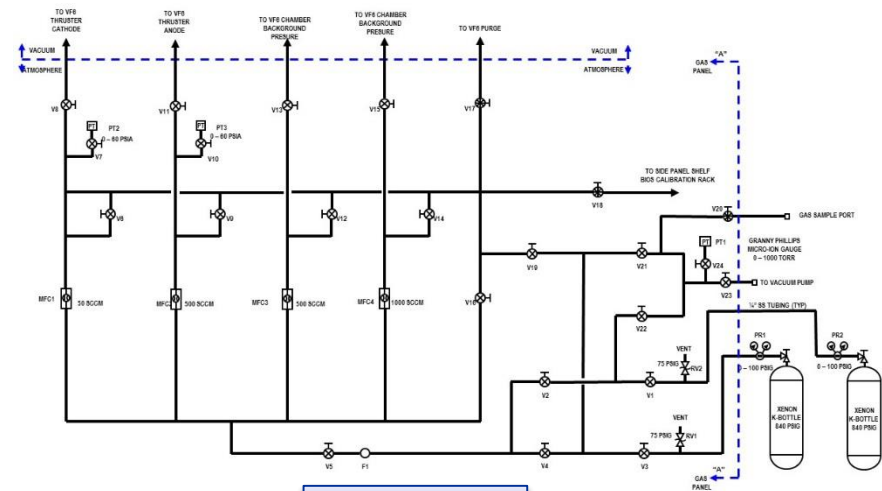

XFS schematic

Internal Xenon Propellant System

- Latch isolation valves on the anode and cathode downstream of the thrust stand
- Internal pressure transducers to monitor anode and cathode pressures near the thruster

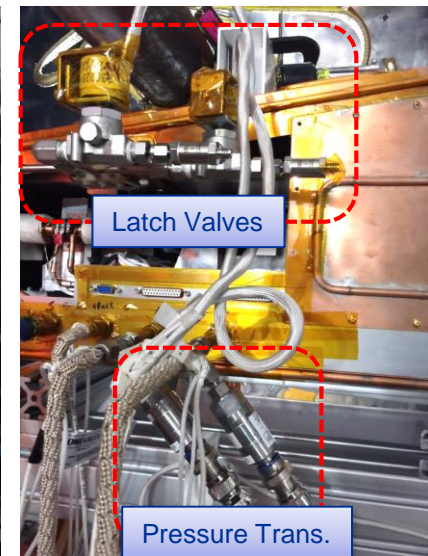



RESULT & DISCUSSION

Thruster Performance

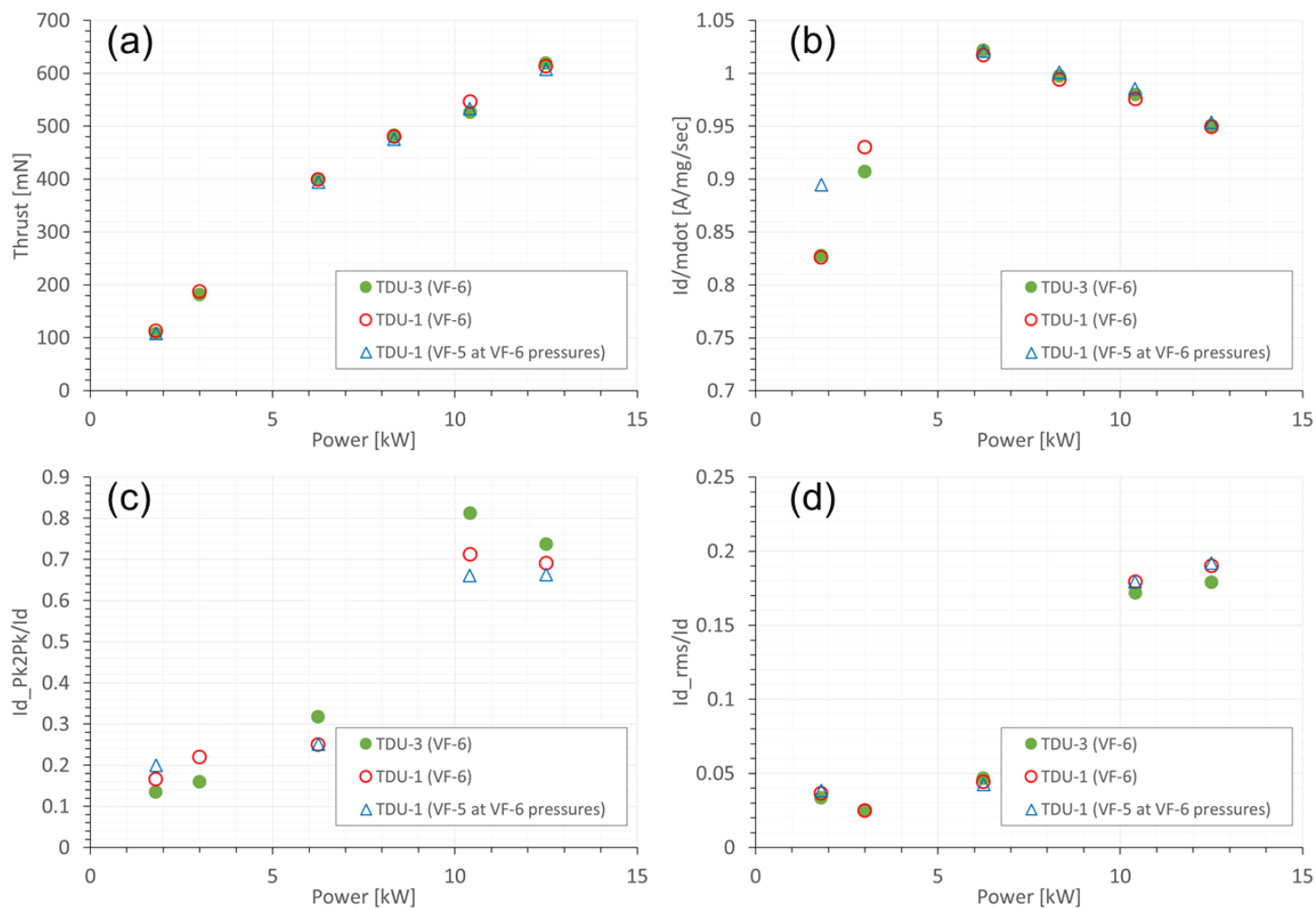

The measured performance of the TDU-1 and TDU-3 in VF-6 was the same as results from VF-5 at equivalent background pressures



Plume Characterization

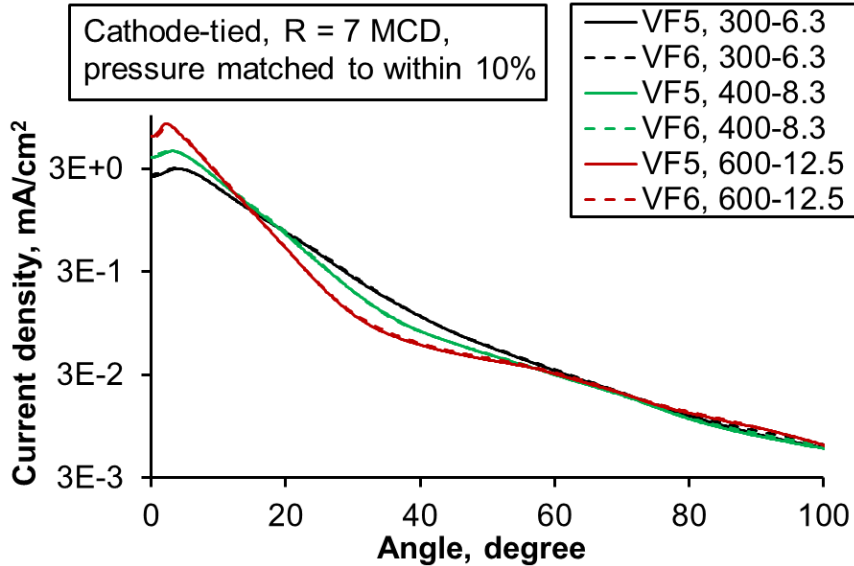

The TDU-1 mapped plasma properties in VF-6 are very similar to those obtained in VF-5 at equivalent background pressures

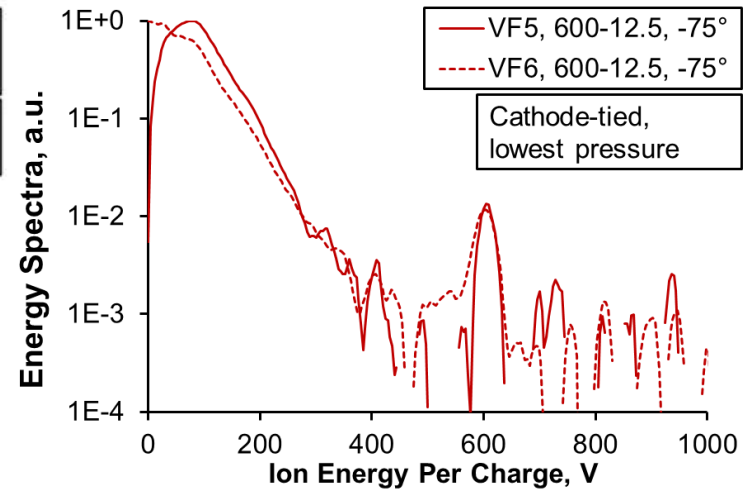
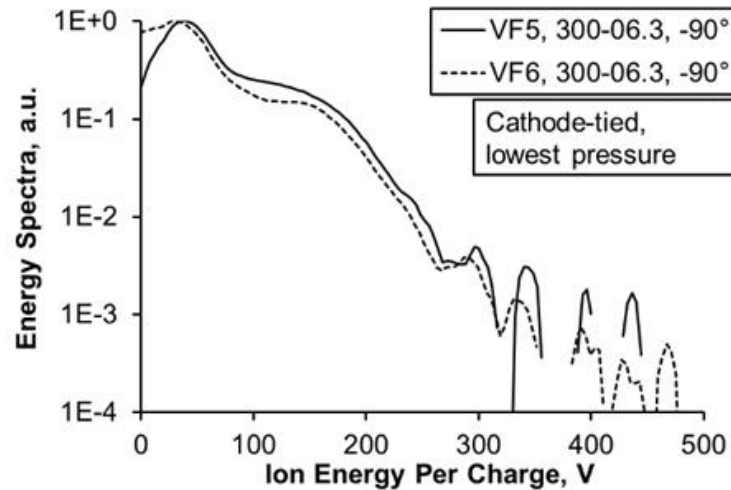

Conclusions

- NASA VF-6 has successfully been reconfigured for high-power EP testing
 - ✓ Power
 - ✓ Propellant
 - ✓ Diagnostics
 - ✓ DAQ
 - ✓ Backspitter
- Performance and plume mapping of the HERMeS TDU-1 and TDU-3 thruster show that VF-6 is fully capable of providing NASA with an additional vacuum facility for the AEPS project and other high-power EP testing
- VF-6 has since been used to in both AEPS (*EIST, IEPC-2017-223*) and HERMeS (*IEPC-2017-338*) testing campaigns



