



National Aeronautics and Space Administration

Building Aerodynamic Databases for the SLS Design Process

Stuart Rogers, Derek Dalle, Henry Lee, Jamie Meeroff
Jeff Onufer, William Chan, Thomas Pulliam

SLS Aerodynamics Group
Computational Aerosciences Branch
NASA Ames Research Center

Supercomputing 2017, November 12-16, 2017

SLS: NASA Space Launch System

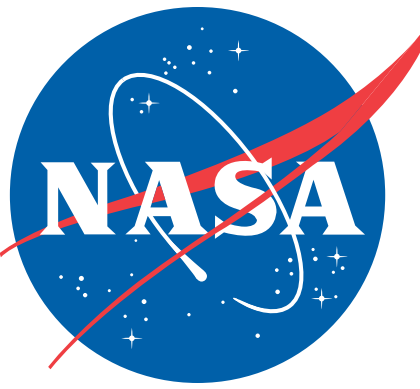

- NASA developed heavy-lift capability
- First rocket to transport astronauts beyond Earth orbit since Saturn V
- 70-metric ton payload capability
- Thrust:
 - 8.4 million pounds
 - 10% more than Saturn V
- Payload more than three times of the Space Shuttle



SLS: NASA Space Launch System Family

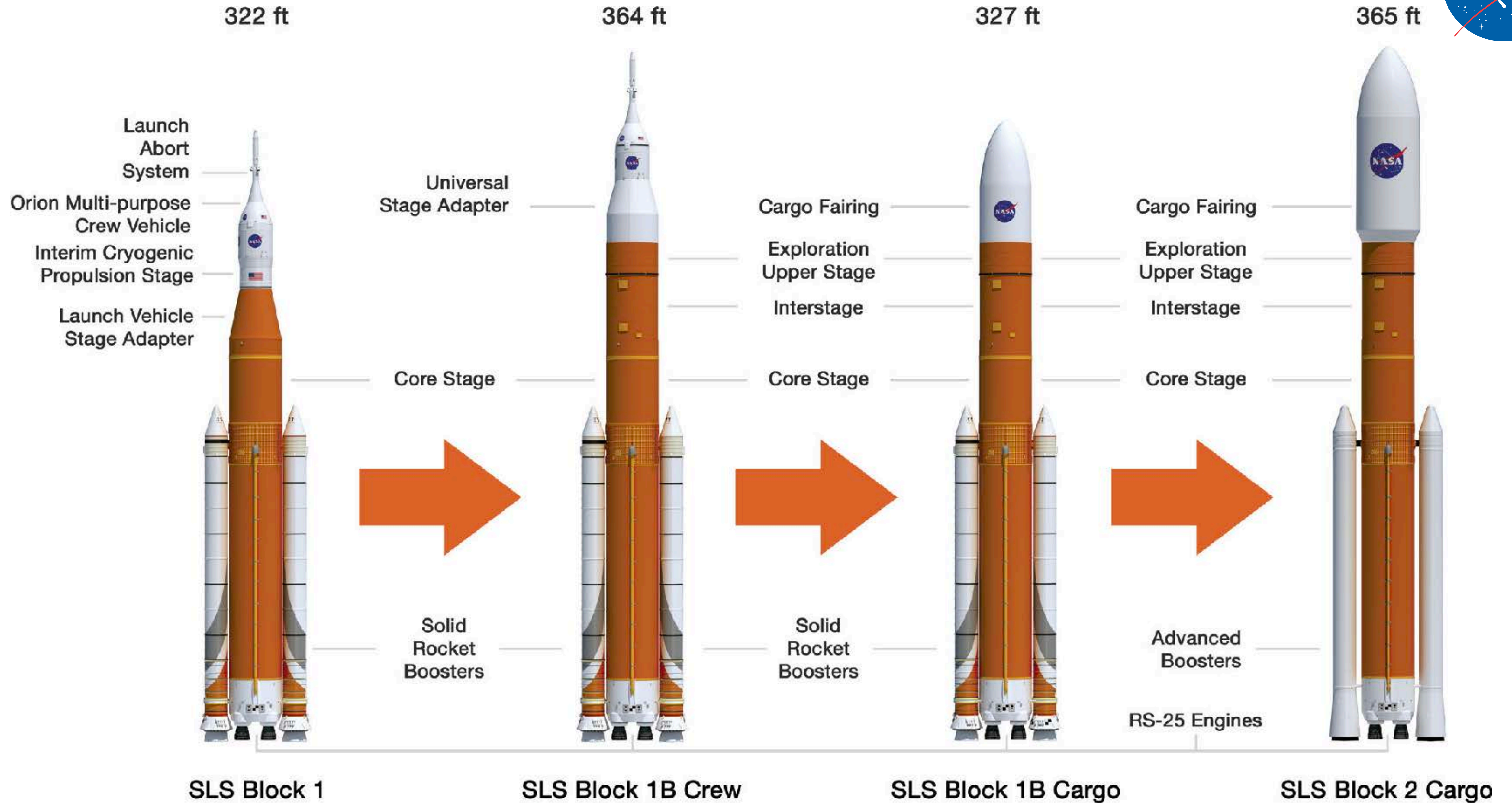
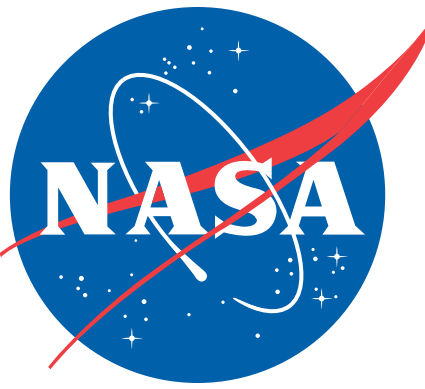

SLS: NASA Space Launch System Block 1

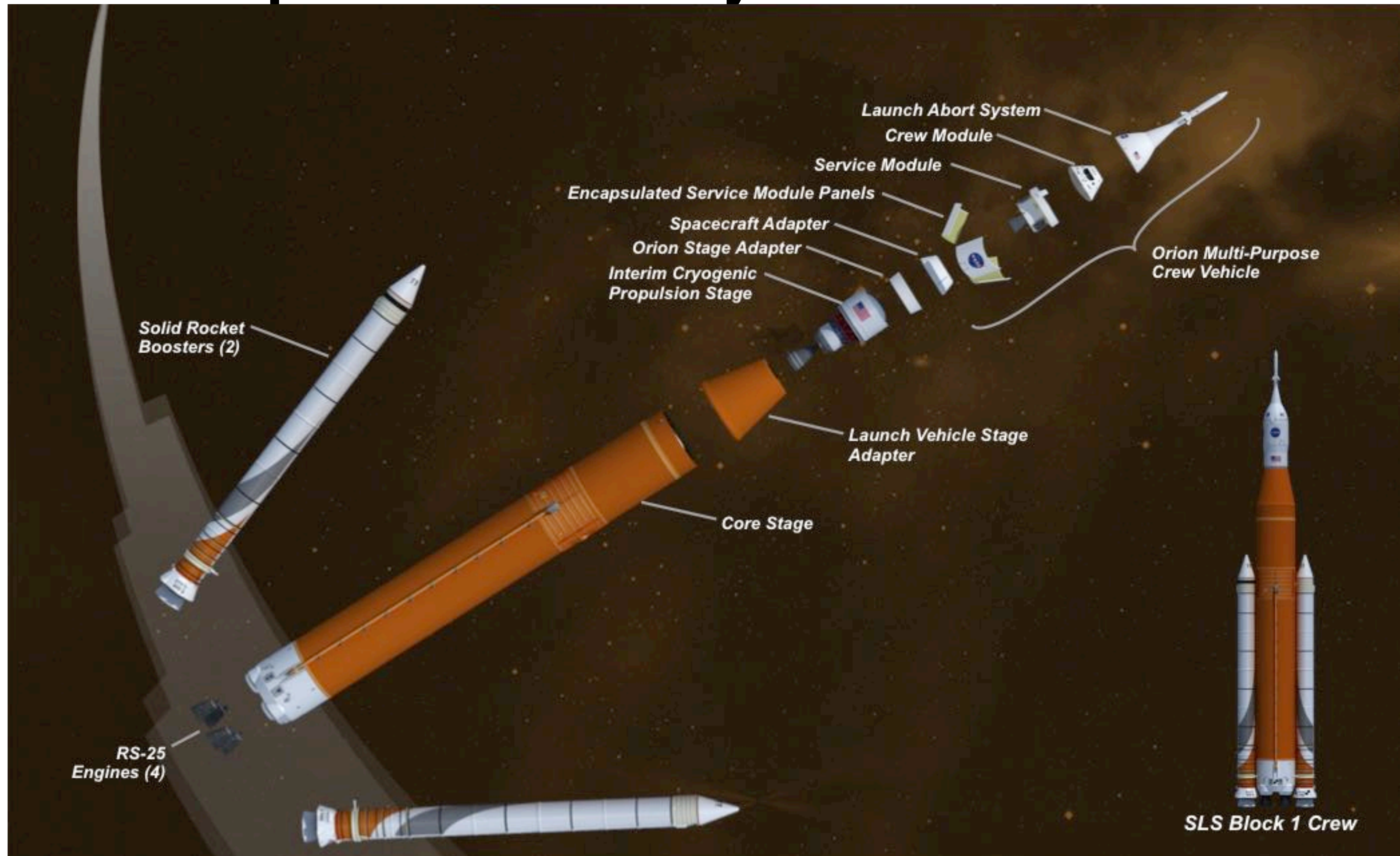
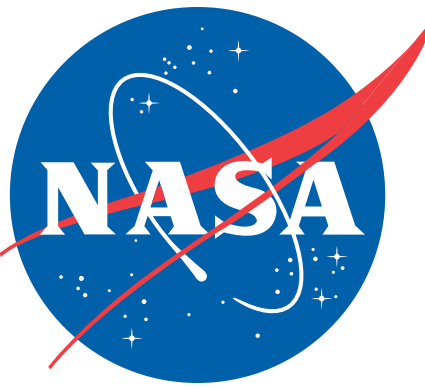

SLS: NASA Space Launch System Block 1B Crew

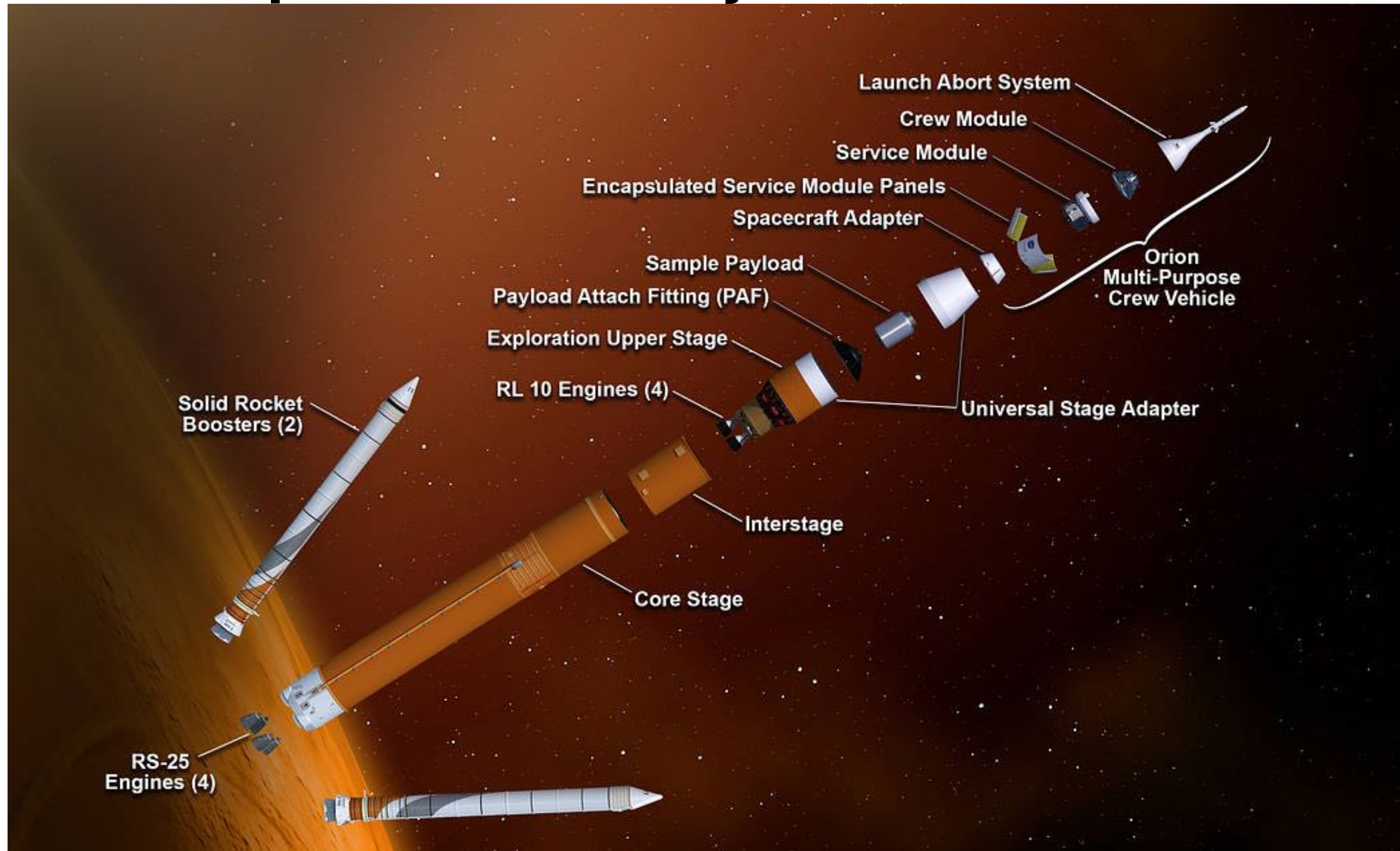
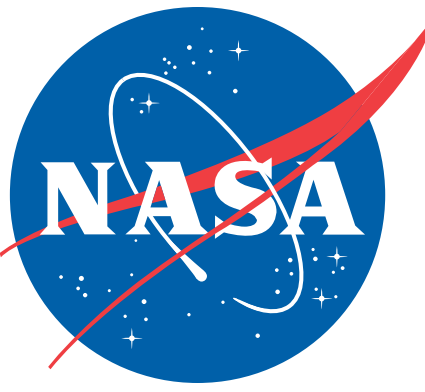

SLS: NASA Space Launch System Block 2 Cargo

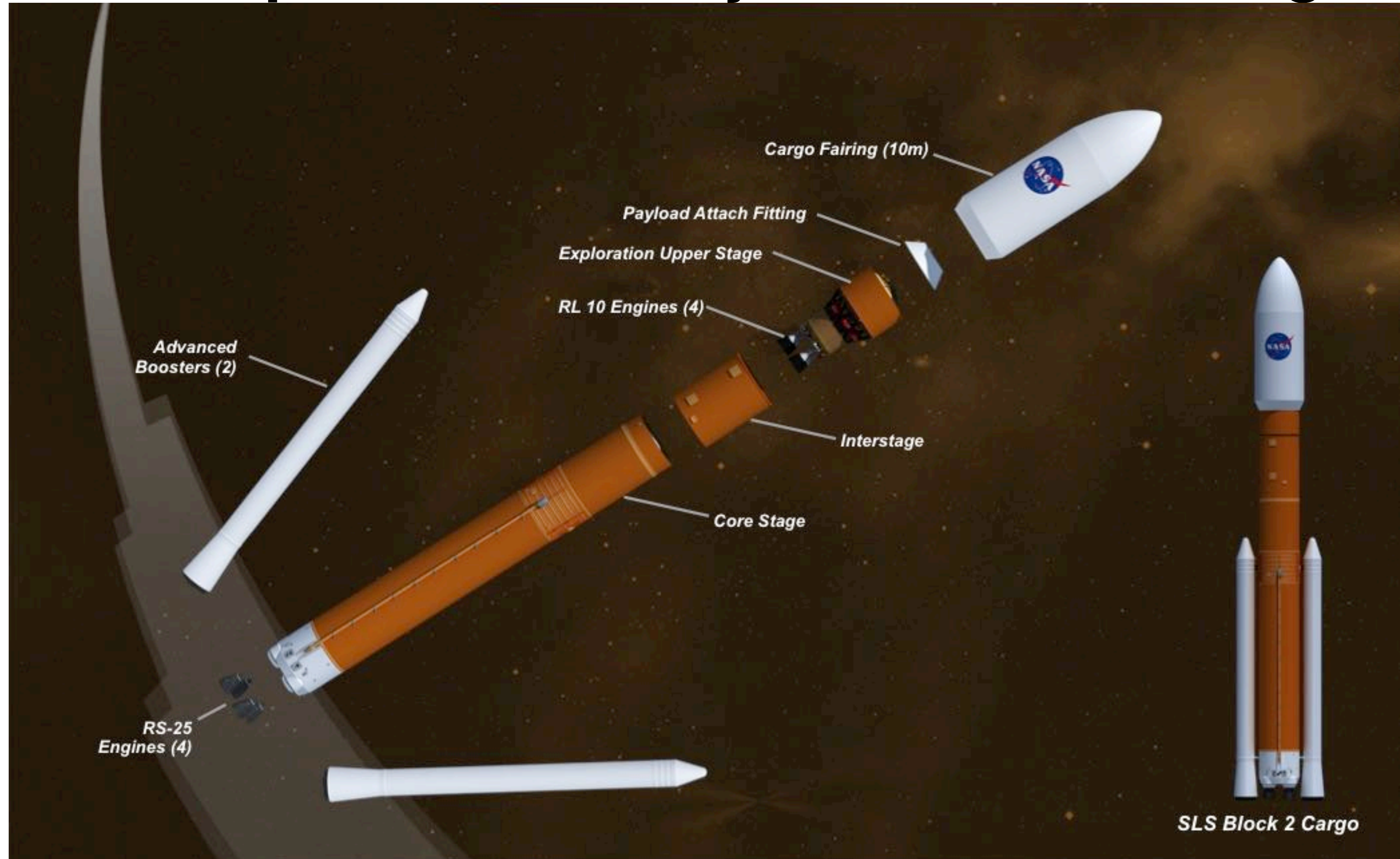
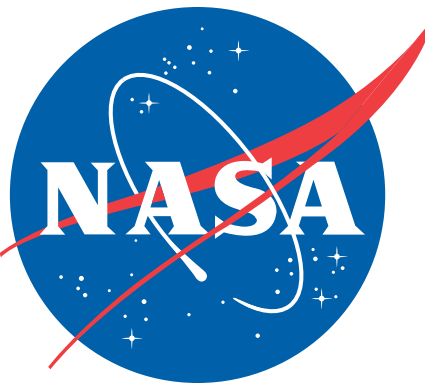

SLS: Future of Exploration

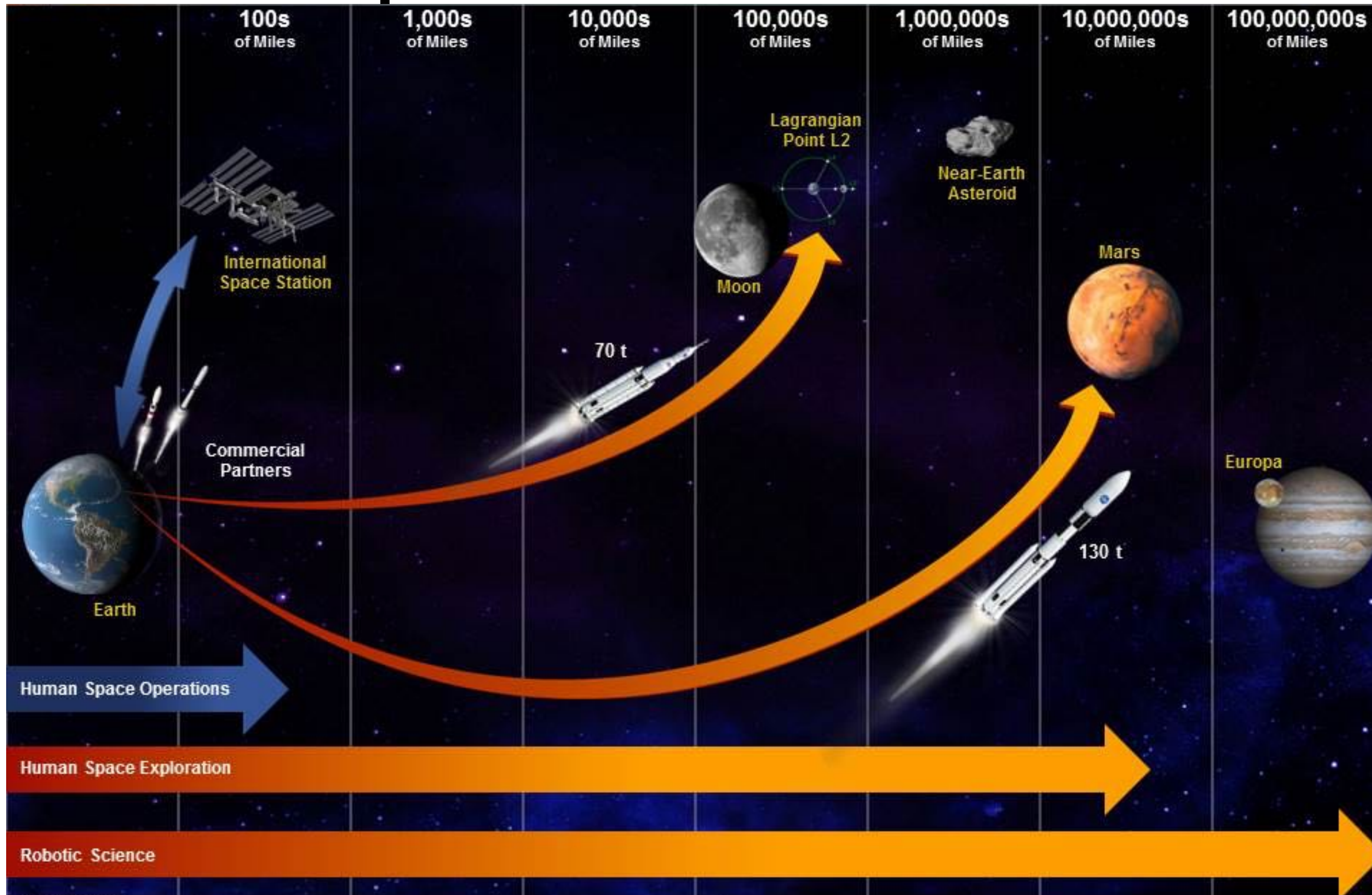
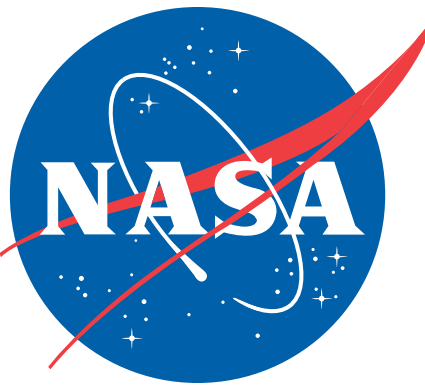

SLS Liftoff, Ascent, and Booster Separation

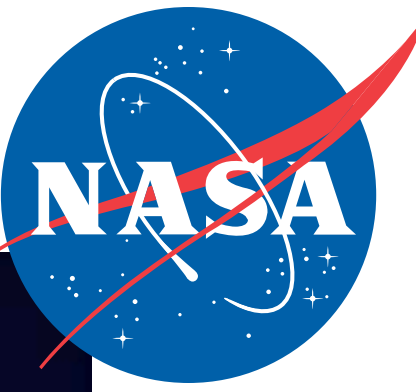

Building Aerodynamic Database: Ascent

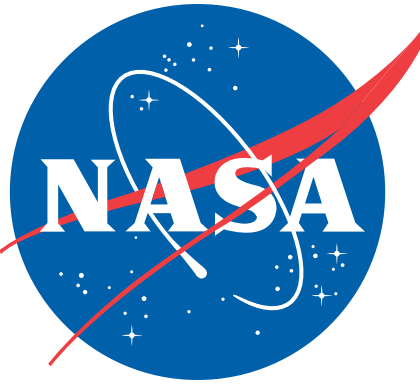

- Provide forces and moments on core and both boosters
- Complicated fluid dynamics: plume interactions
- Large data
 - Many independent parameters
 - Flight geometry & Wind-tunnel geometry
 - Static cases
- Computational Fluid Dynamics (CFD)
 - FUN3D viscous CFD solver
 - Overflow viscous CFD solver

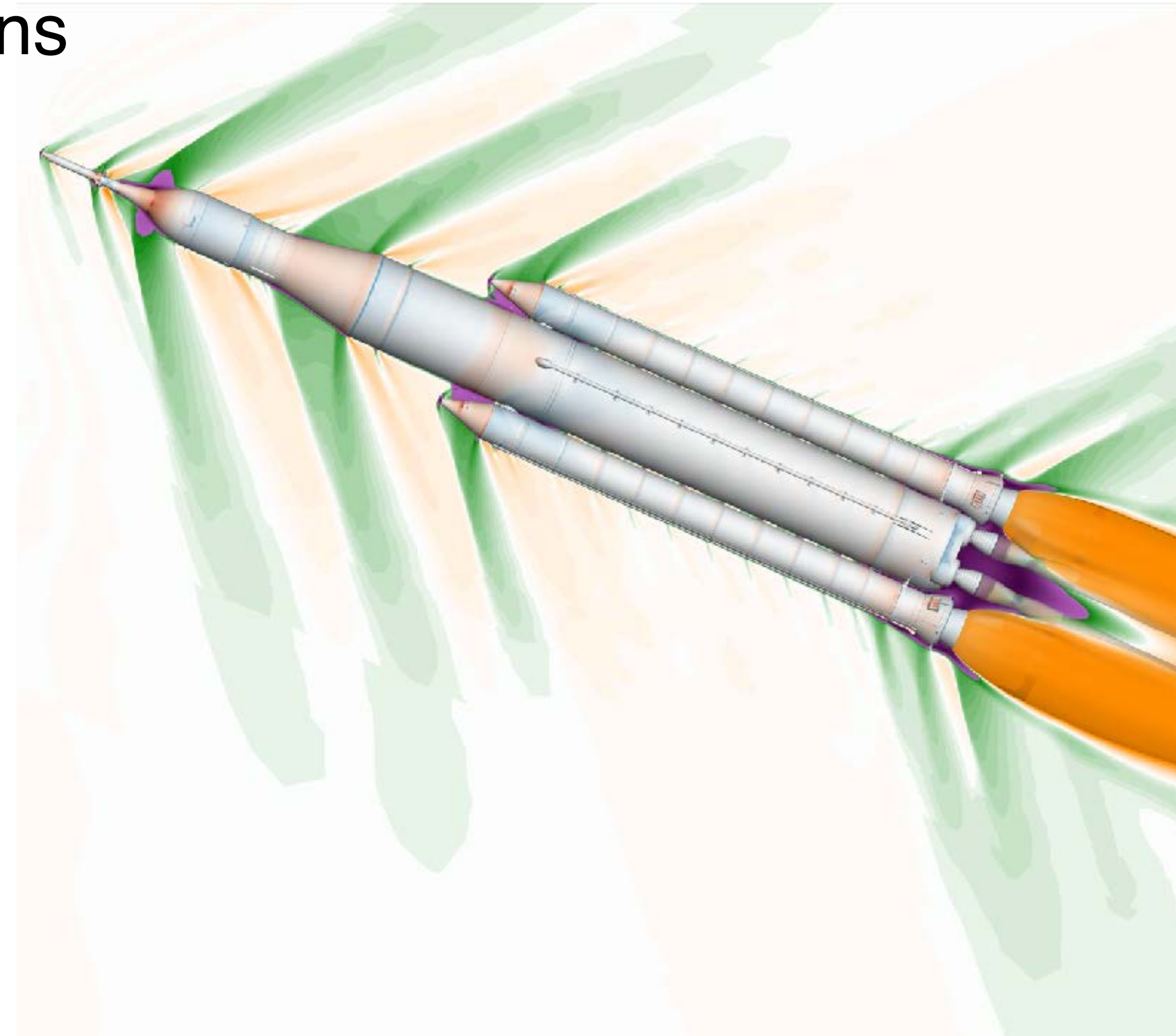

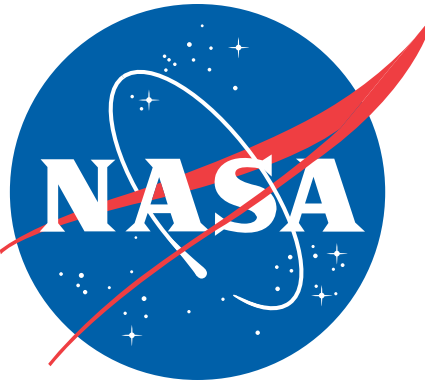

Ascent Aerodynamics Database

- Three-Dimensional run matrix
 - Mach number (altitude)
 - Angle of attack
 - Roll Angle
- Rectangular 2-D run matrix based on Mach number
- 1300+ cases total



Angle of
Attack

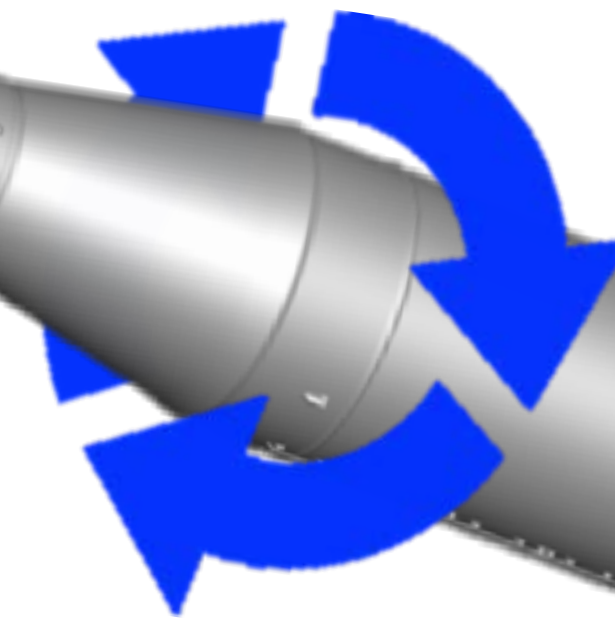

Roll Angle

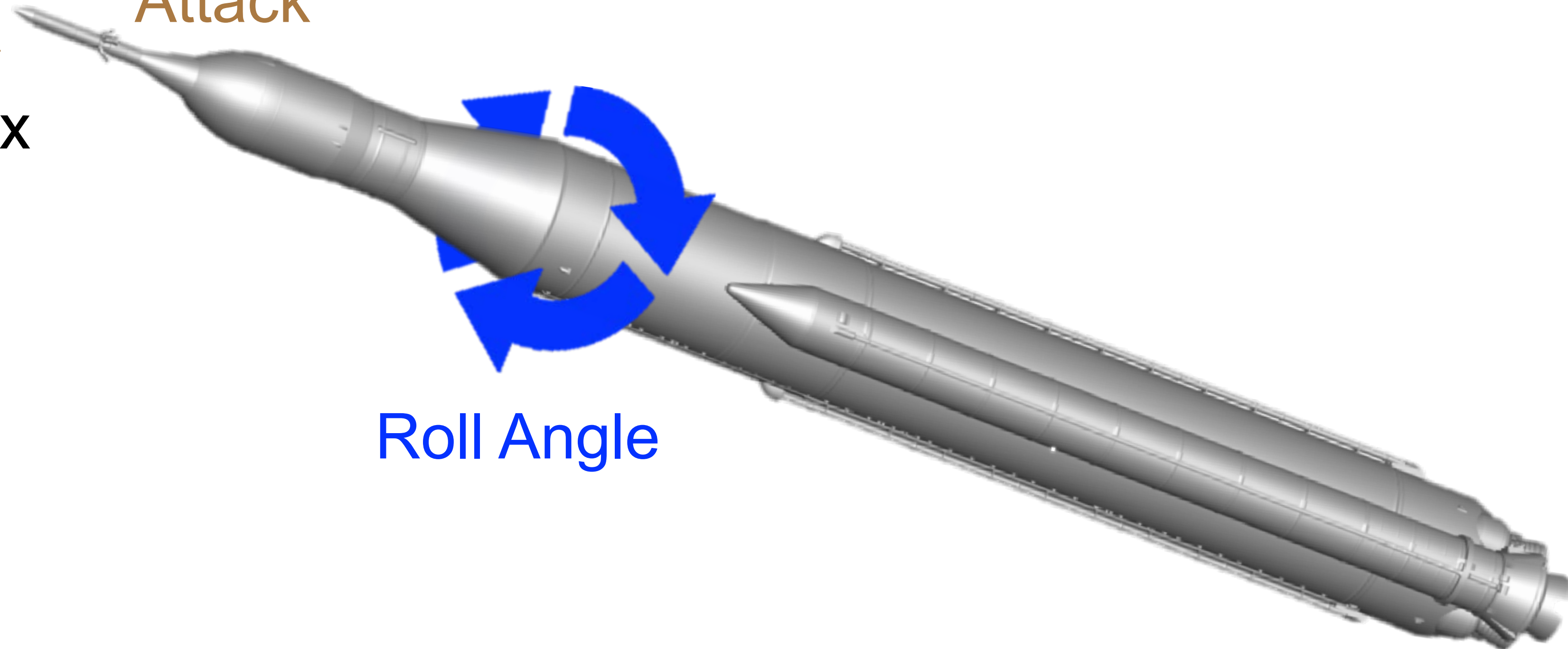

Building Aerodynamic Database: Booster Separation

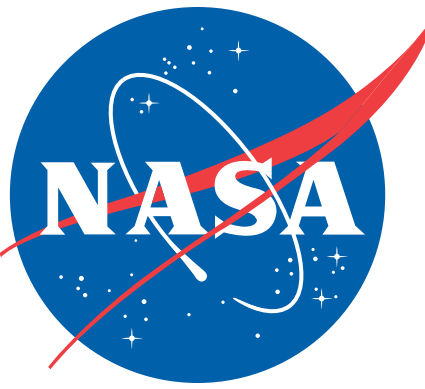

- Provide forces and moments on core and both boosters
- Complicated fluid dynamics: 14 engine plumes firing
- Large data
 - Many independent parameters
 - Off-nominal conditions: core engine out, BSM out
 - Flight geometry & Wind-tunnel geometry
 - Static and Dynamic cases
- Computational Fluid Dynamics (CFD)
 - Cart3D inviscid CFD solver
 - FUN3D viscous CFD solver
 - Overflow viscous CFD solver
 - Overflow-D viscous dynamic moving body CFD solver

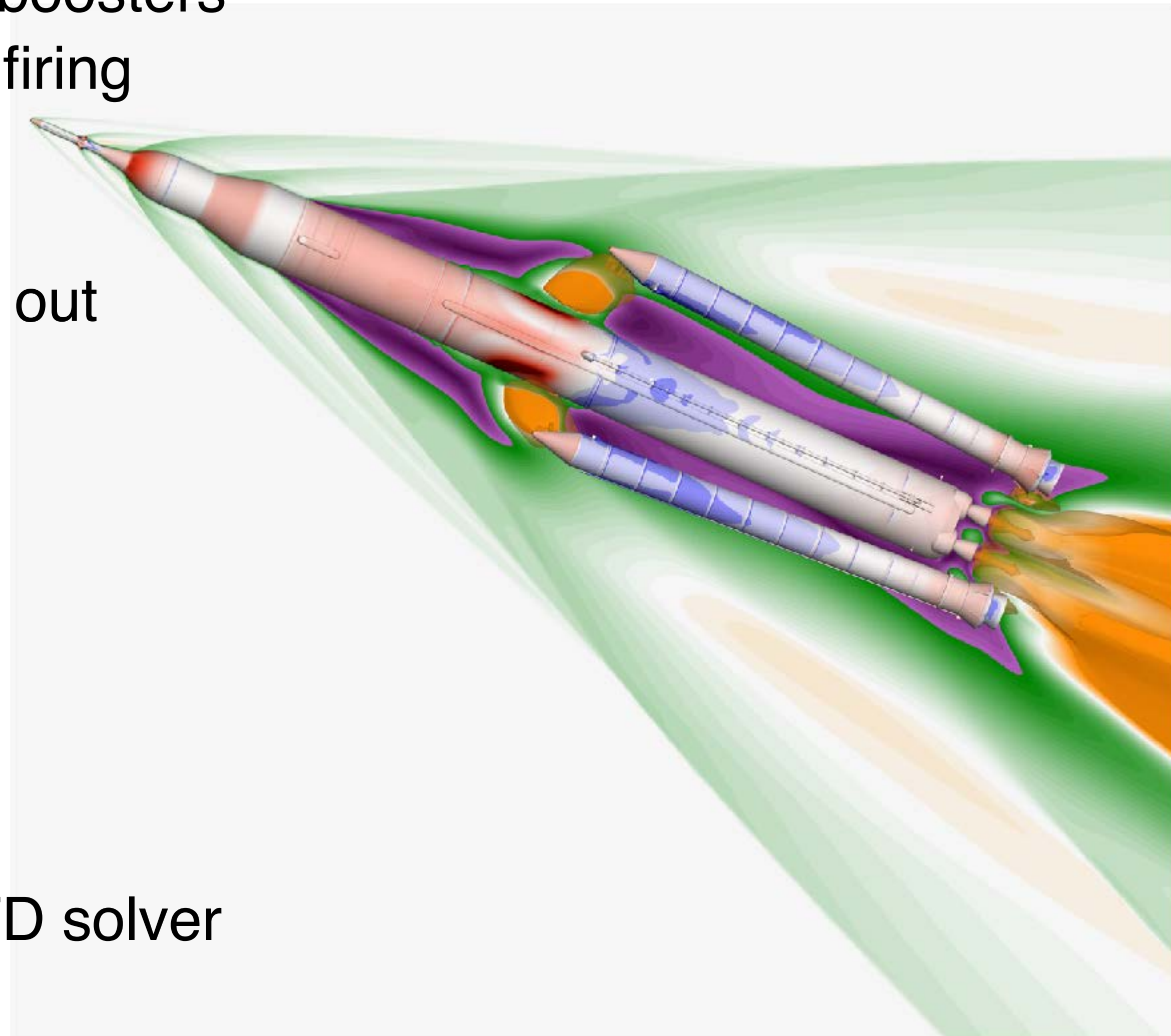

Booster Separation Aerodynamics Database

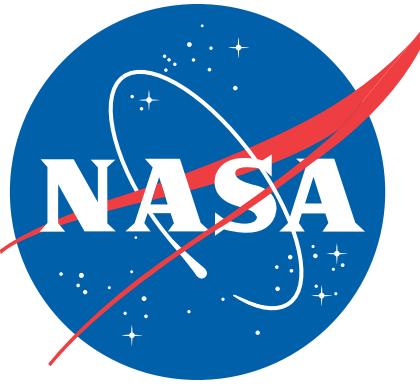

- Eight-Dimensional run matrix
 - Translational variables - 3
 - Rotational variables - 2
 - Thrust of booster separation motors - 1
 - Freestream conditions - 2

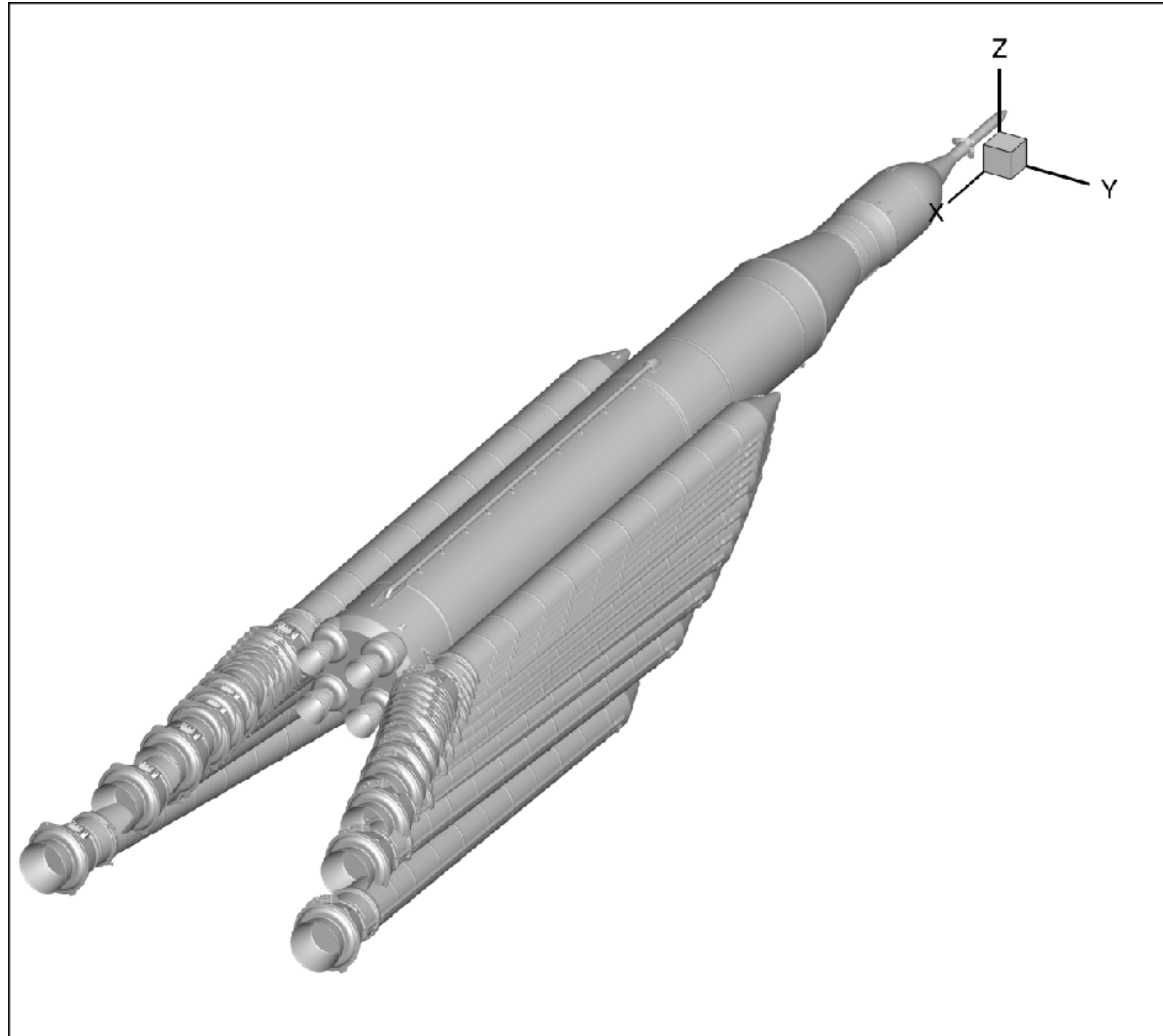

Booster Separation Aerodynamics Database

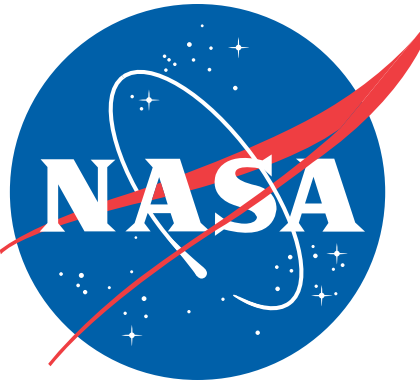

- Eight-Dimensional run matrix
 - Translational variables - 3
 - Rotational variables - 2
 - Thrust of booster separation motors - 1
 - Freestream conditions - 2
- 7-dimensional rectangular run matrix for each dx value

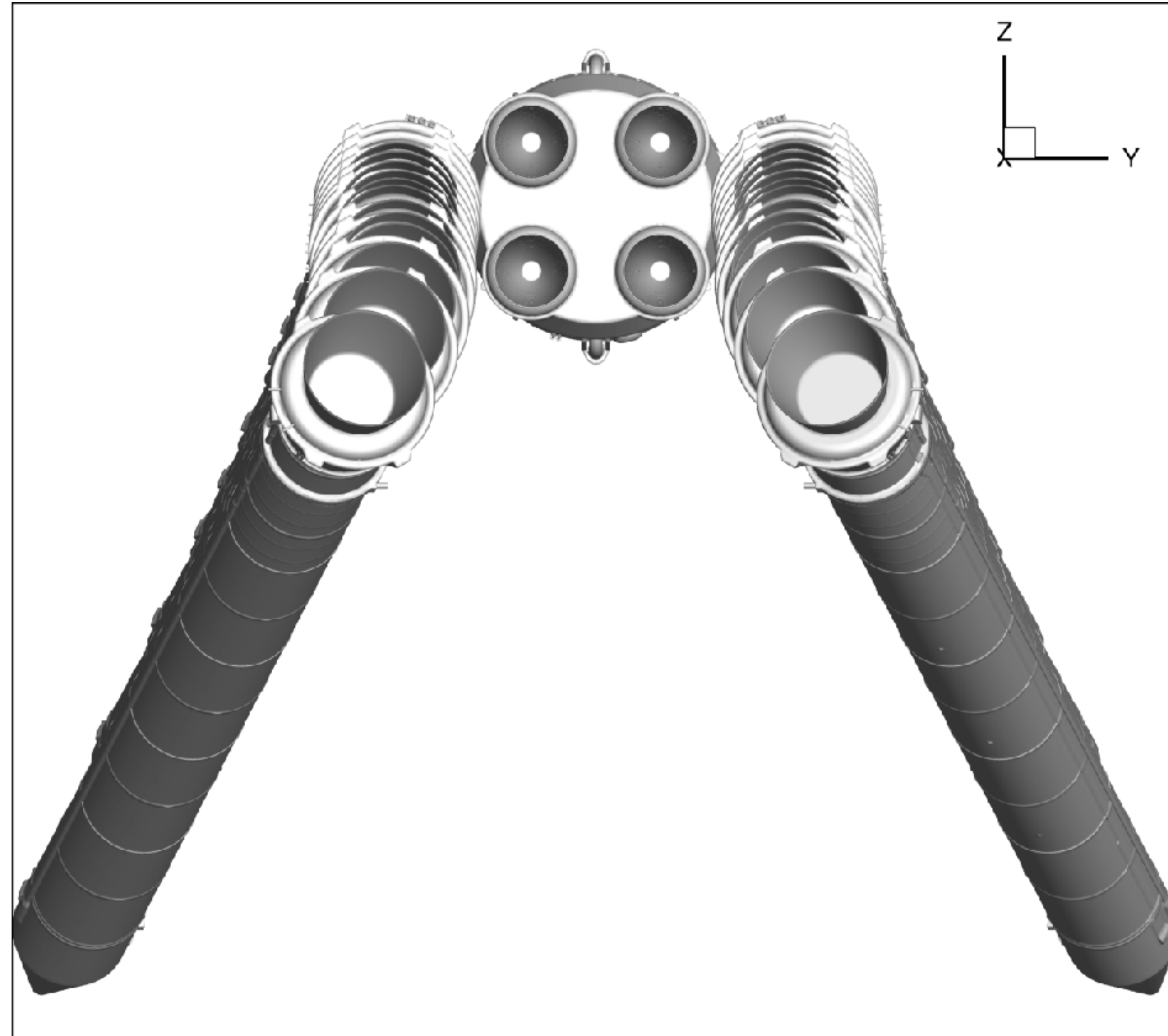

Booster Separation Aerodynamics Database

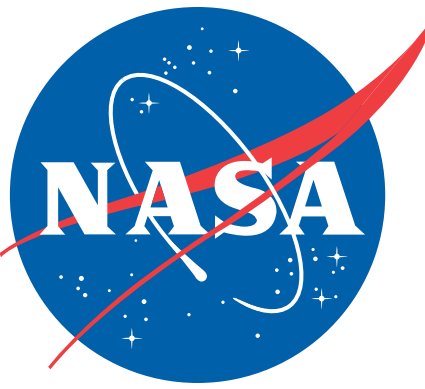

- Eight-Dimensional run matrix
 - Translational variables - 3
 - Rotational variables - 2
 - Thrust of booster separation motors - 1
 - Freestream conditions - 2
- 7-dimensional rectangular run matrix for each dx value
- Pyramid-shaped run matrix

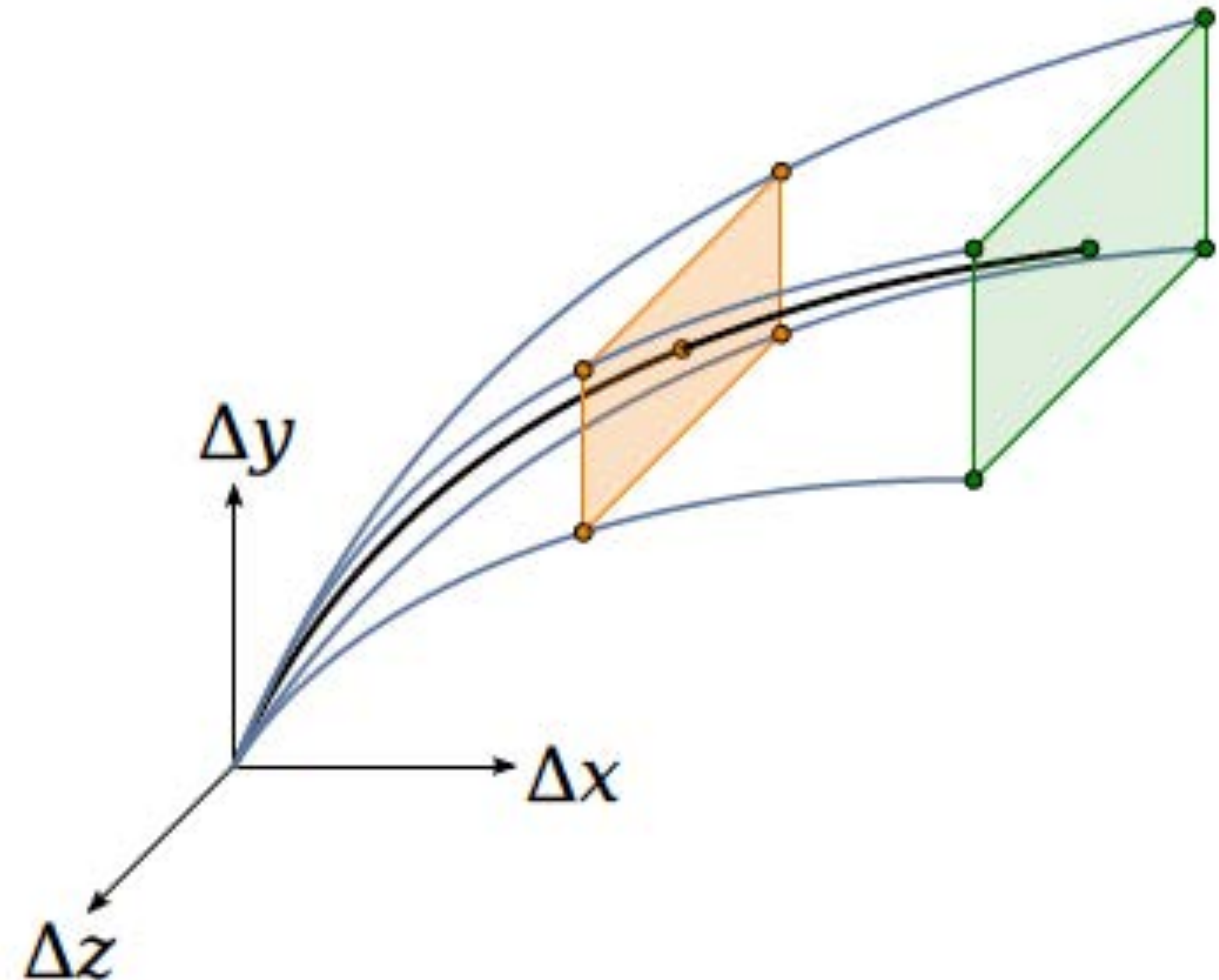

Booster Separation Aerodynamics Database

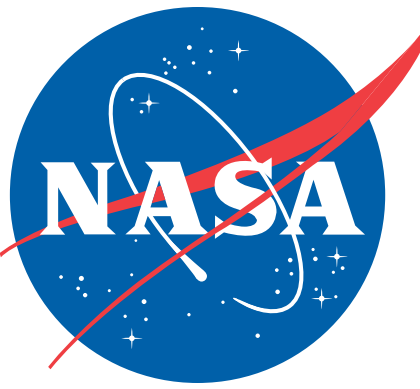

- Eight-Dimensional run matrix
 - Translational variables - 3
 - Rotational variables - 2
 - Thrust of booster separation motors - 1
 - Freestream conditions - 2
- 7-dimensional rectangular run matrix for each dx value
- Pyramid-shaped run matrix
- 22,000+ runs required

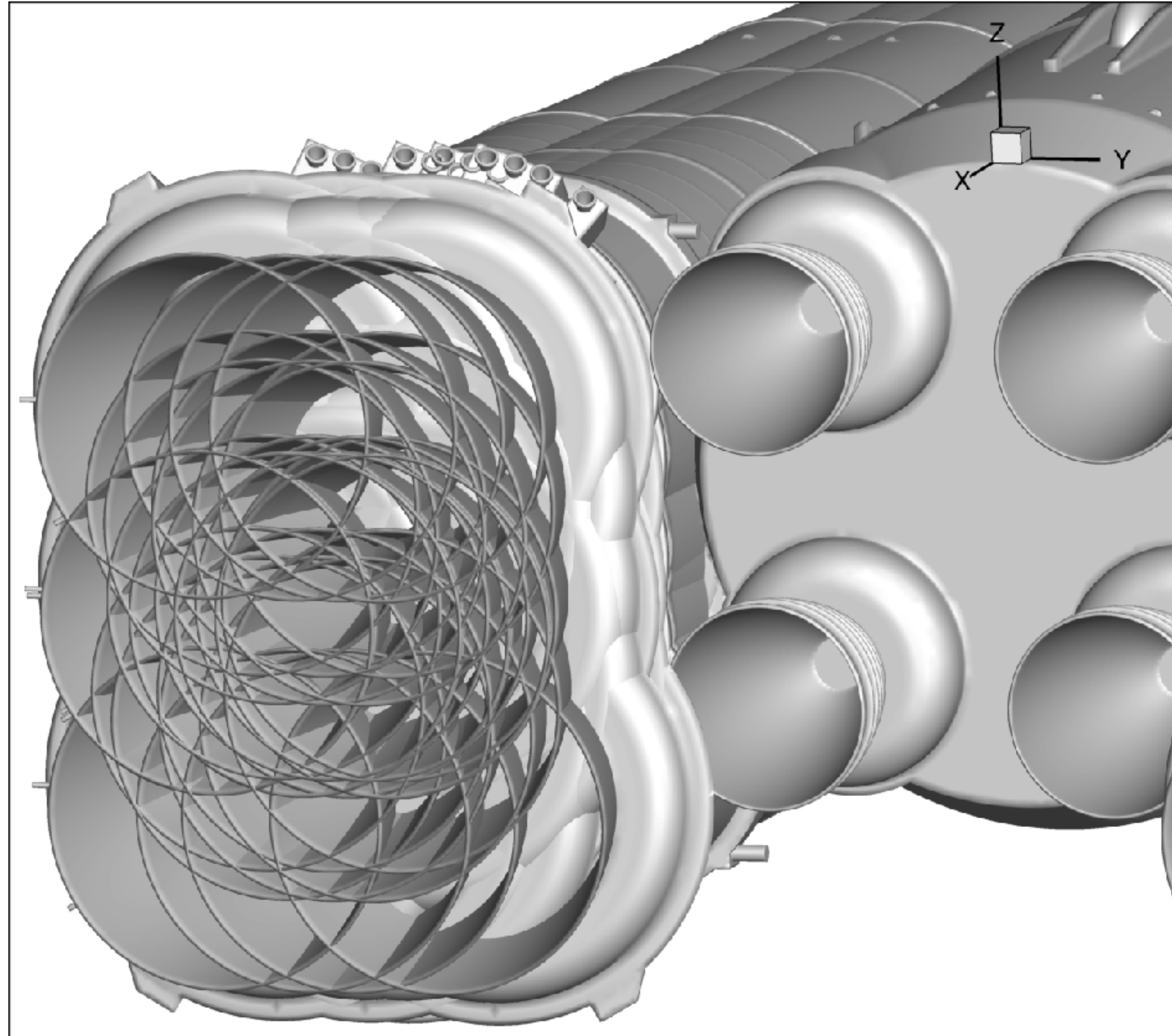

NAS Pleiades & Electra Supercomputer

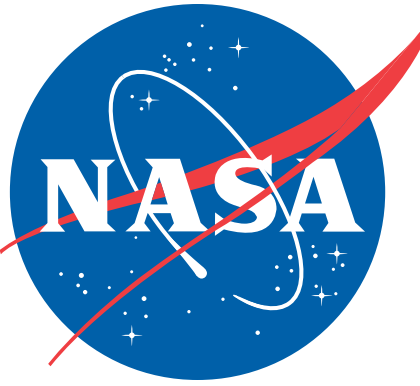

- SGI Ice cluster with Intel Xeon processors
- InfiniBand in a dual-plane hypercube technology
- Pleiades
 - 7.24 Pflop/s peak cluster
 - 11,440 nodes; 246,048 cores
 - 935 TB Memory
 - Broadwell, Haswell, Ivy Bridge, & Sandy Bridge Nodes
- Electra
 - 4.79 Pflops/ peak cluster
 - 2,304 nodes; 78,336 cores
 - 368 TB Memory
 - Skylake and Broadwell Nodes



Computational Resources Consumed 2017

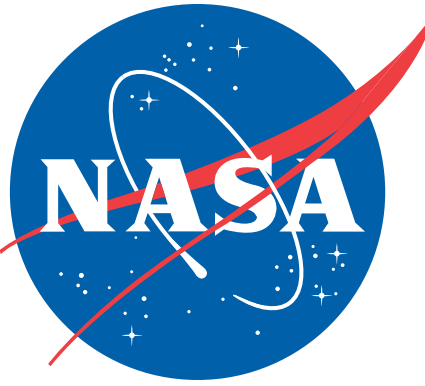

- Over 71 million core hours
- Over 500 terabytes of storage used

- Block 1 Crew Ascent
 - *3000+* cases
 - 36 million core hours
- Block 1B Crew Ascent & Booster Separation
 - *~1,300 + ~3000* cases
 - 25 million core hours
- Block 1B Cargo Ascent Database
 - *~1,300* cases
 - 5 million core hours

SLS Block 1 Crew Ascent

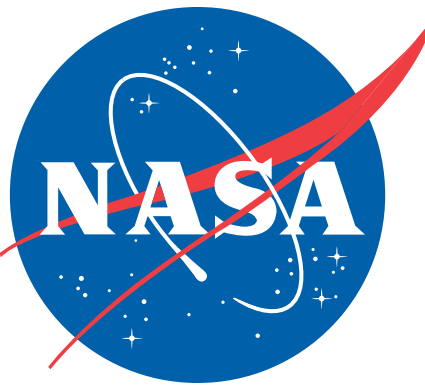

Altitude: Low • • • • • • • • • • High

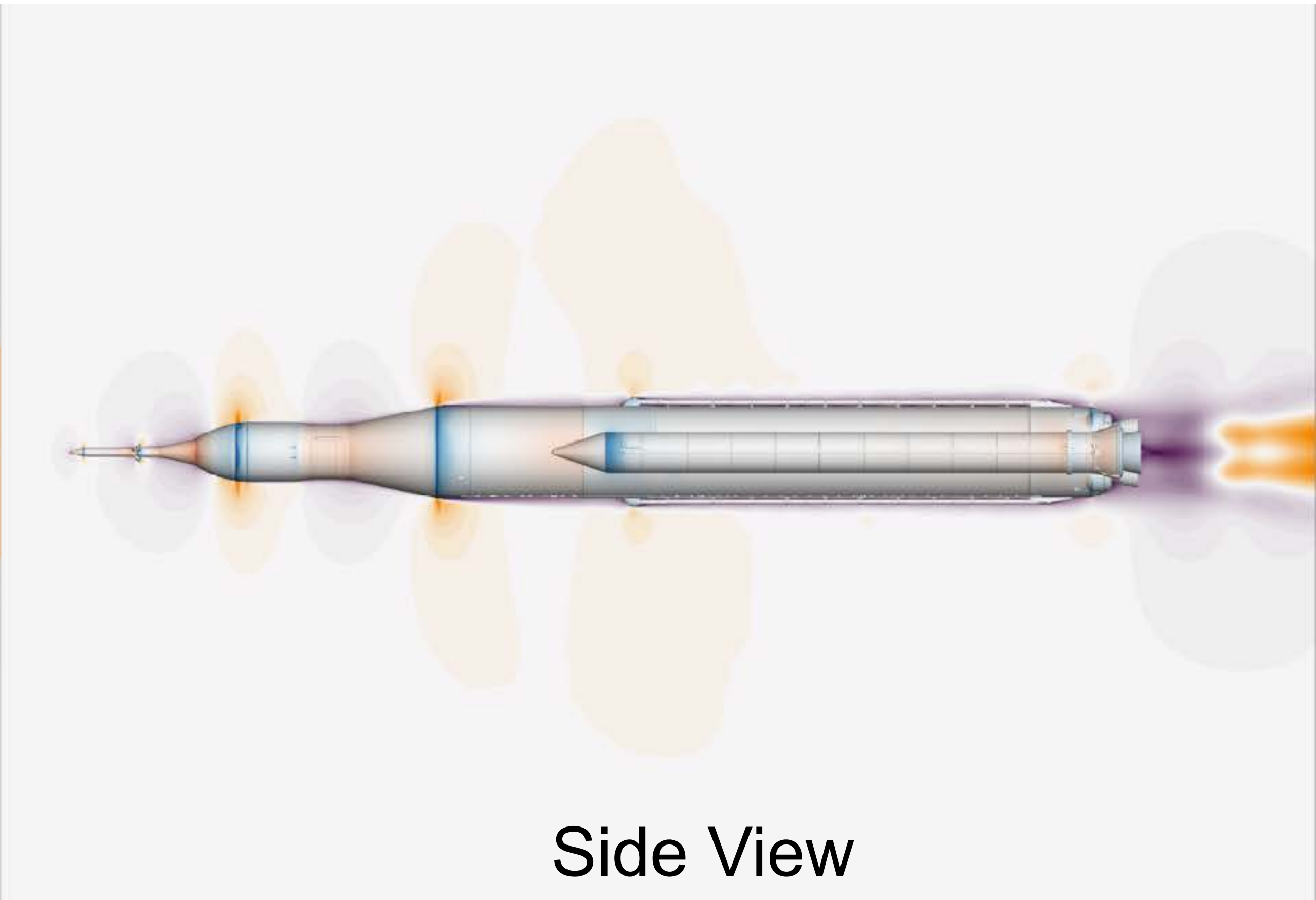
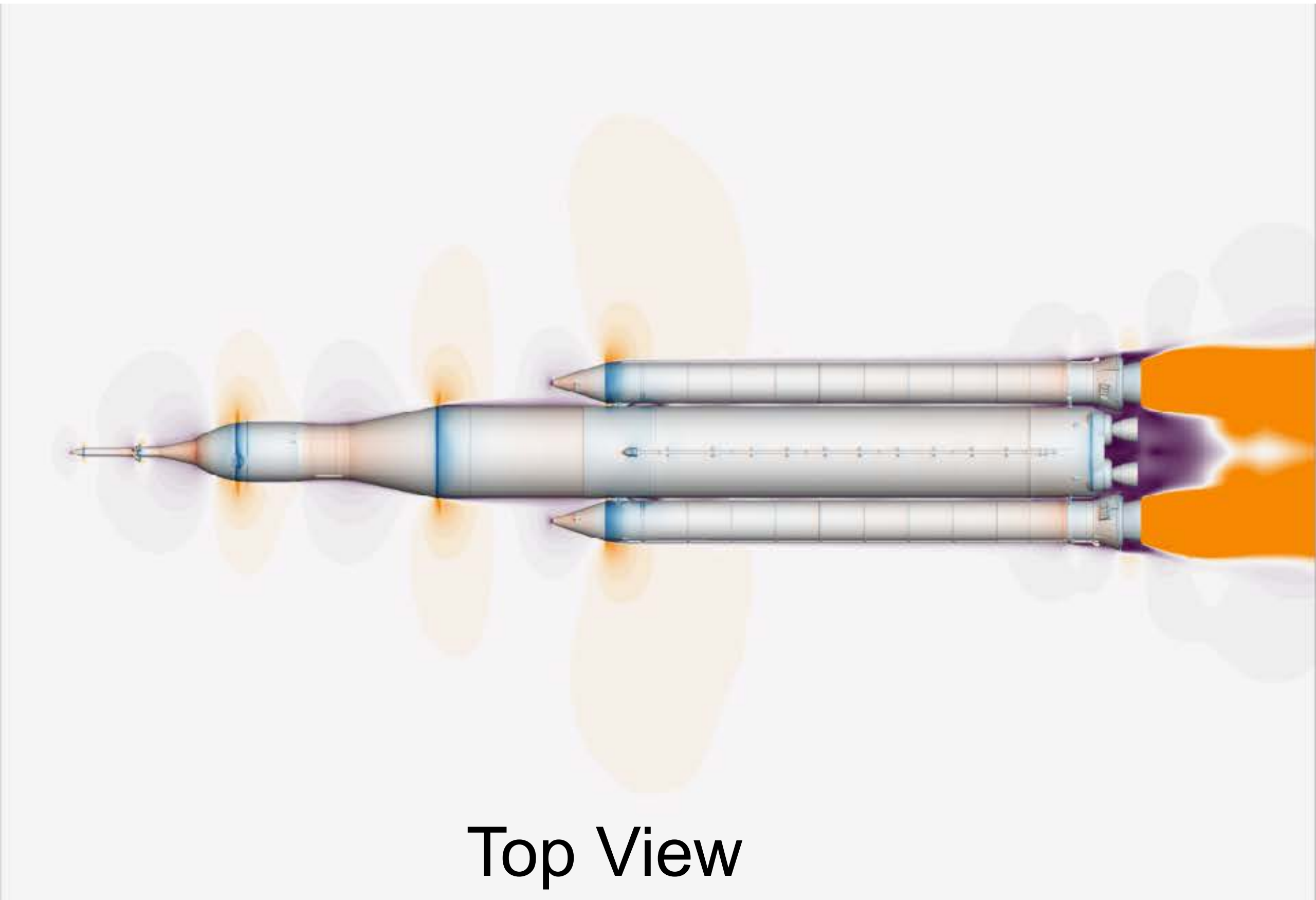

Background slice purple-green-white-orange color contours represent low to high velocities
Vehicle surface blue-white-red color contours represent low to high pressures

SLS Block 1 Crew Ascent

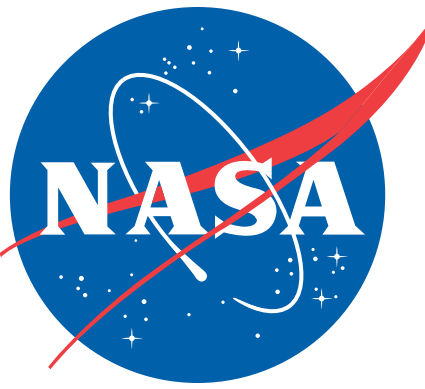

Altitude: Low • • • • • • • • • • High

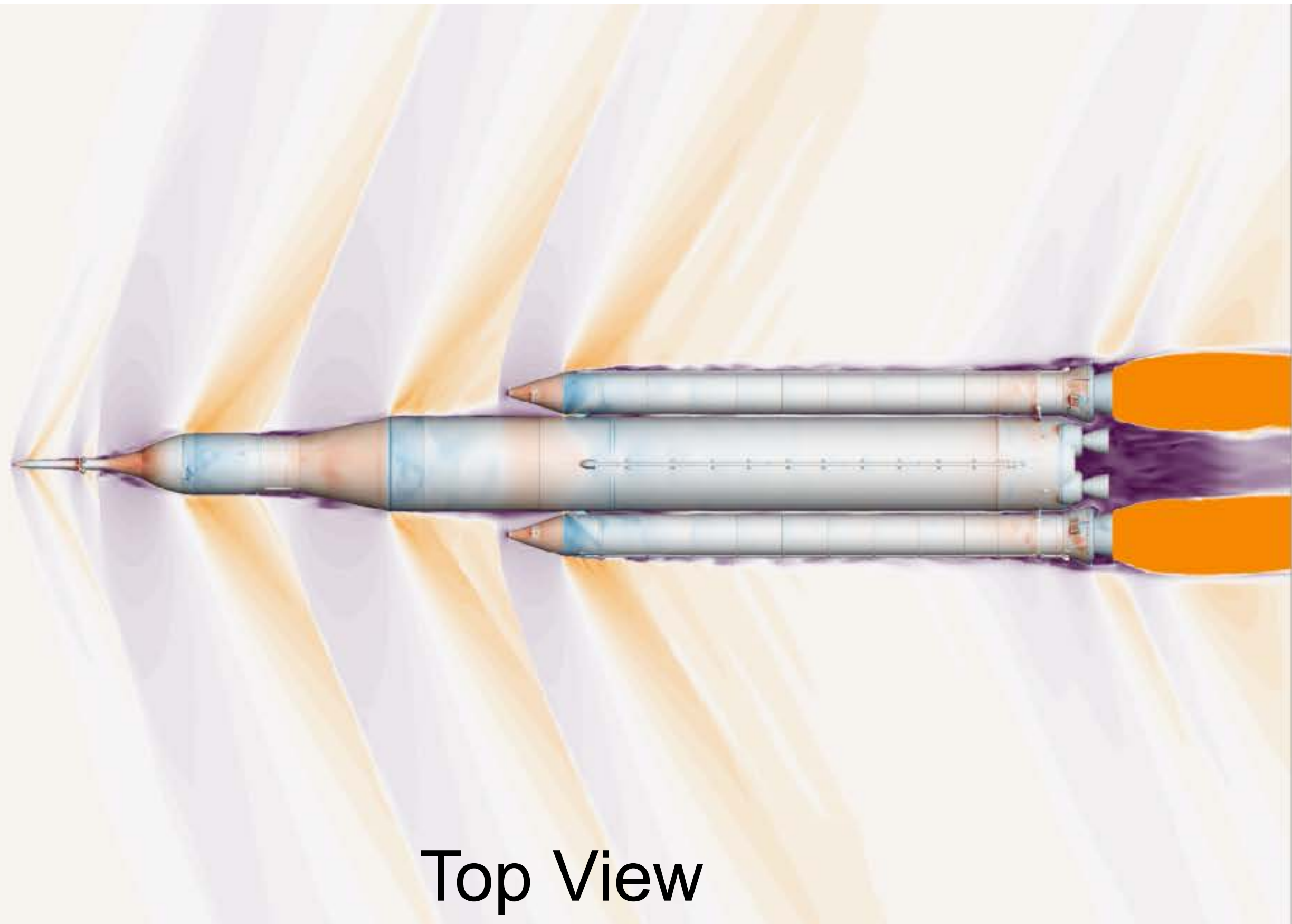

Top View

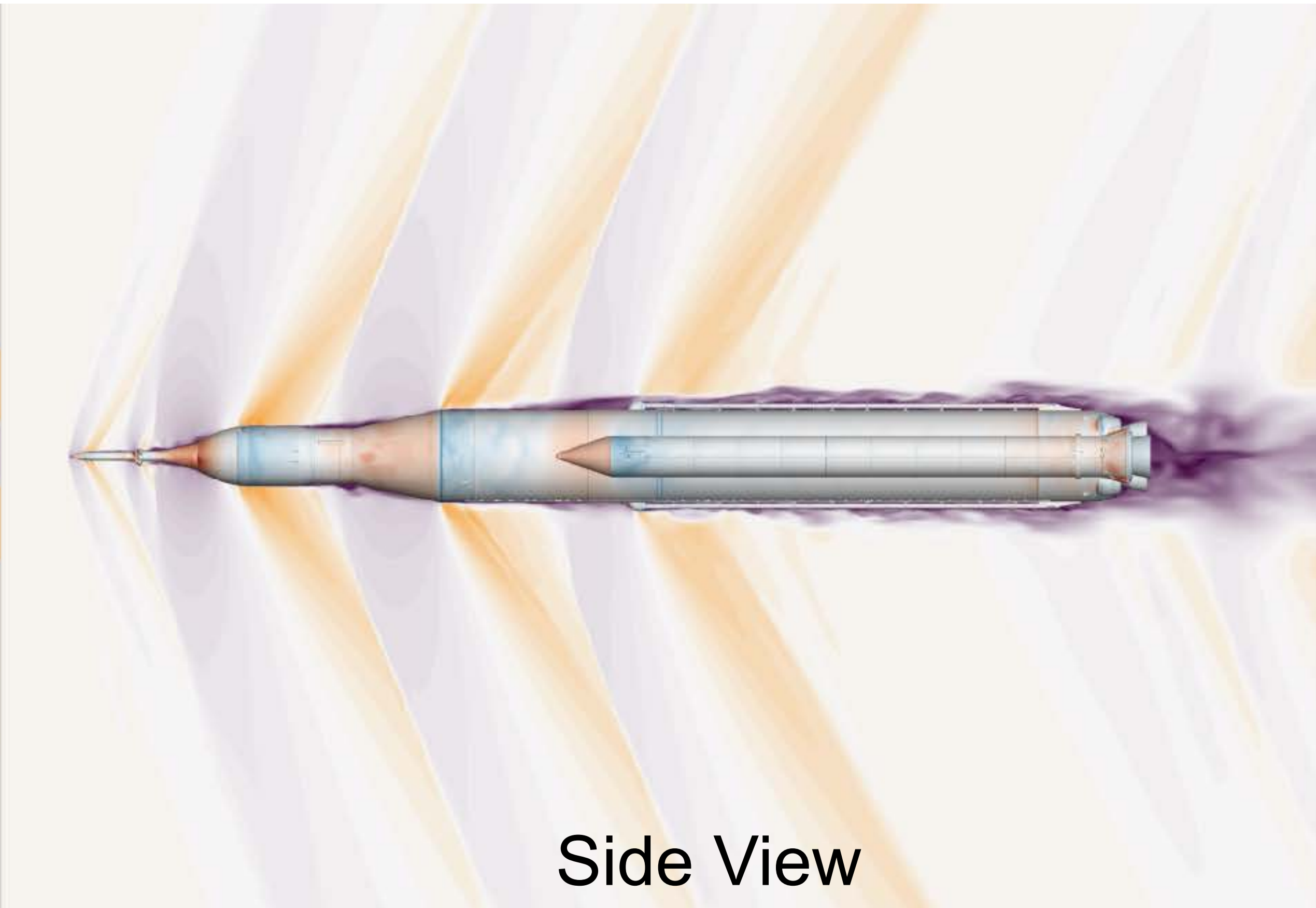

Side View

Background slice purple-green-white-orange color contours represent low to high velocities
Vehicle surface blue-white-red color contours represent low to high pressures

SLS Block 1 Crew Ascent

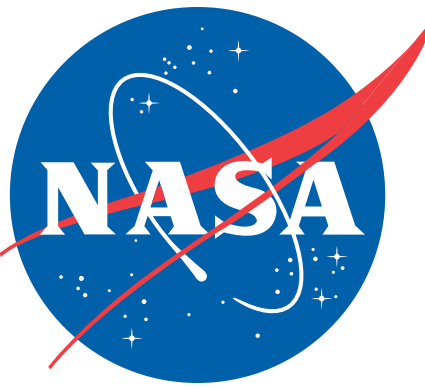

Altitude: Low • • • • • • • • • • High

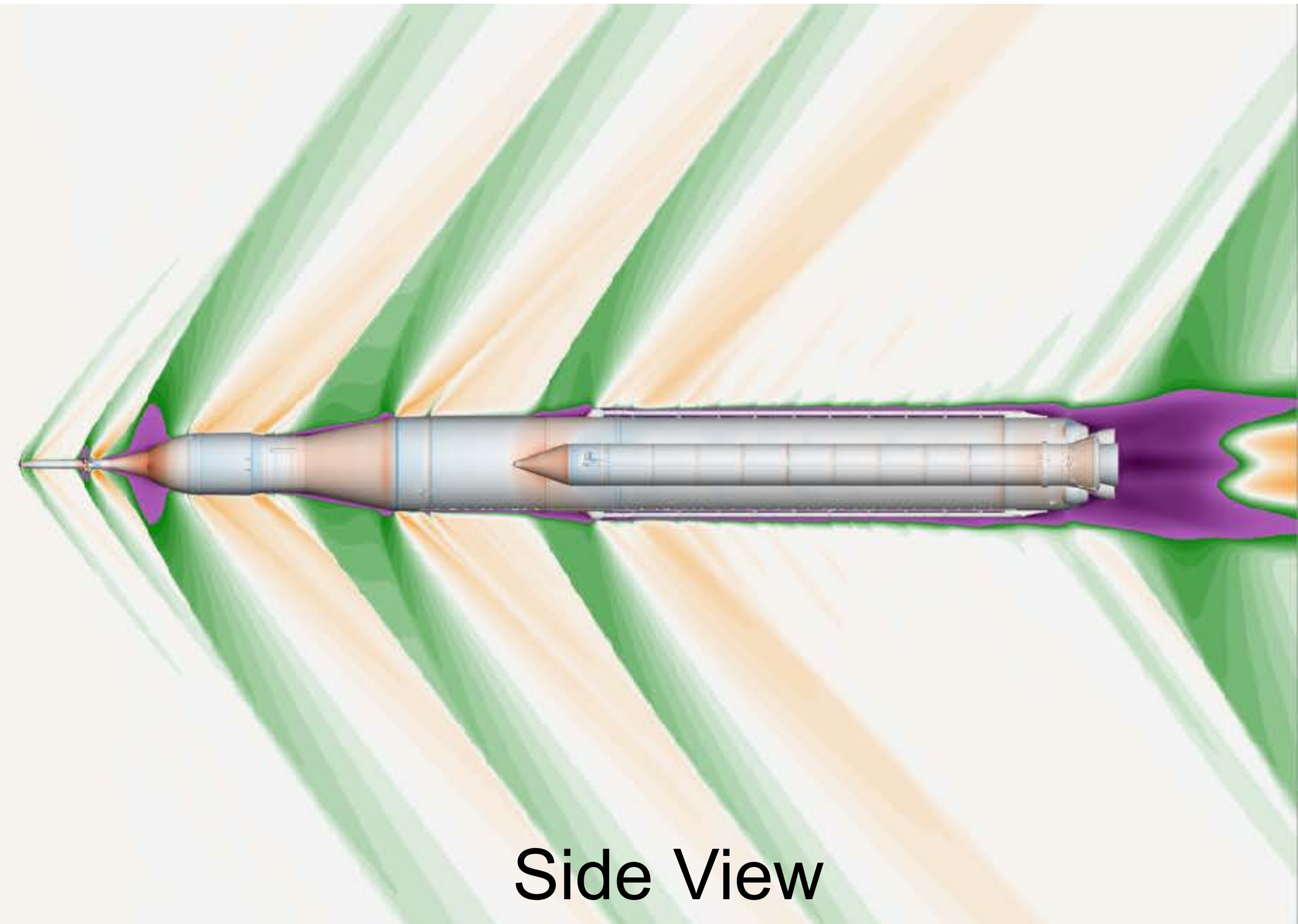
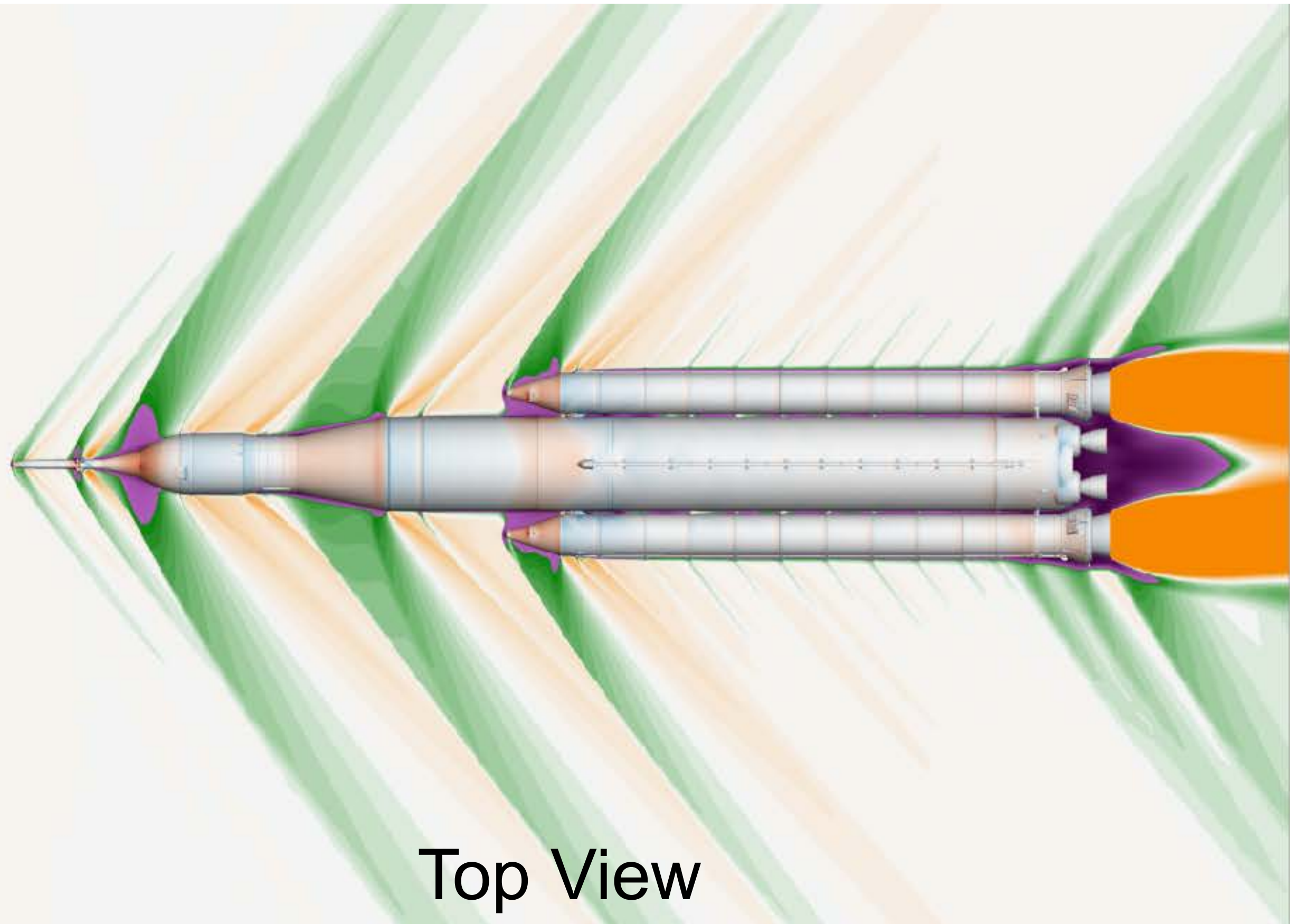

Background slice purple-green-white-orange color contours represent low to high velocities
Vehicle surface blue-white-red color contours represent low to high pressures

SLS Block 1 Crew Ascent

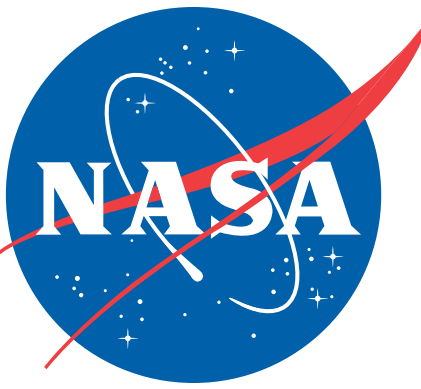

Altitude: Low • • • • • • • • • • High

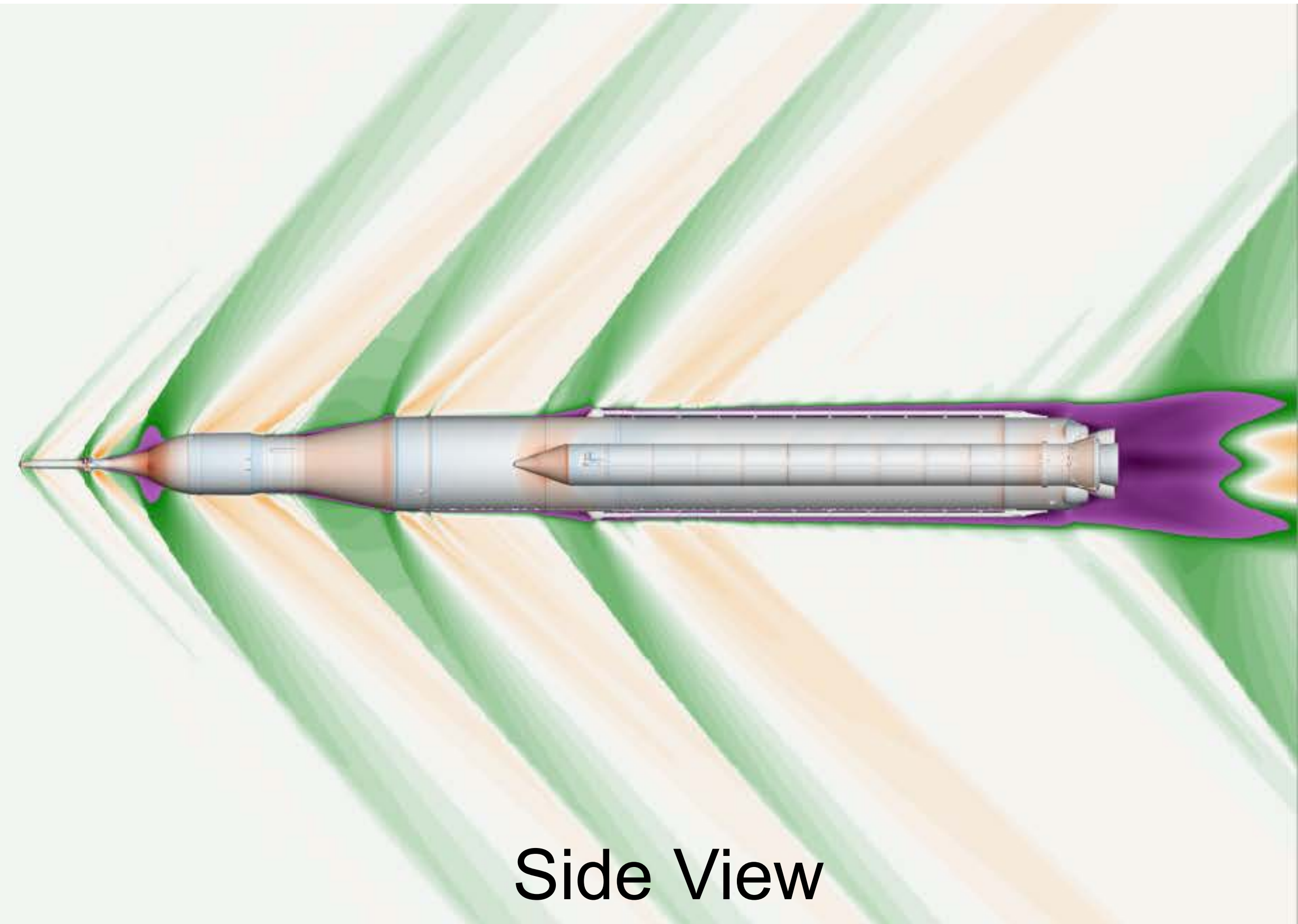
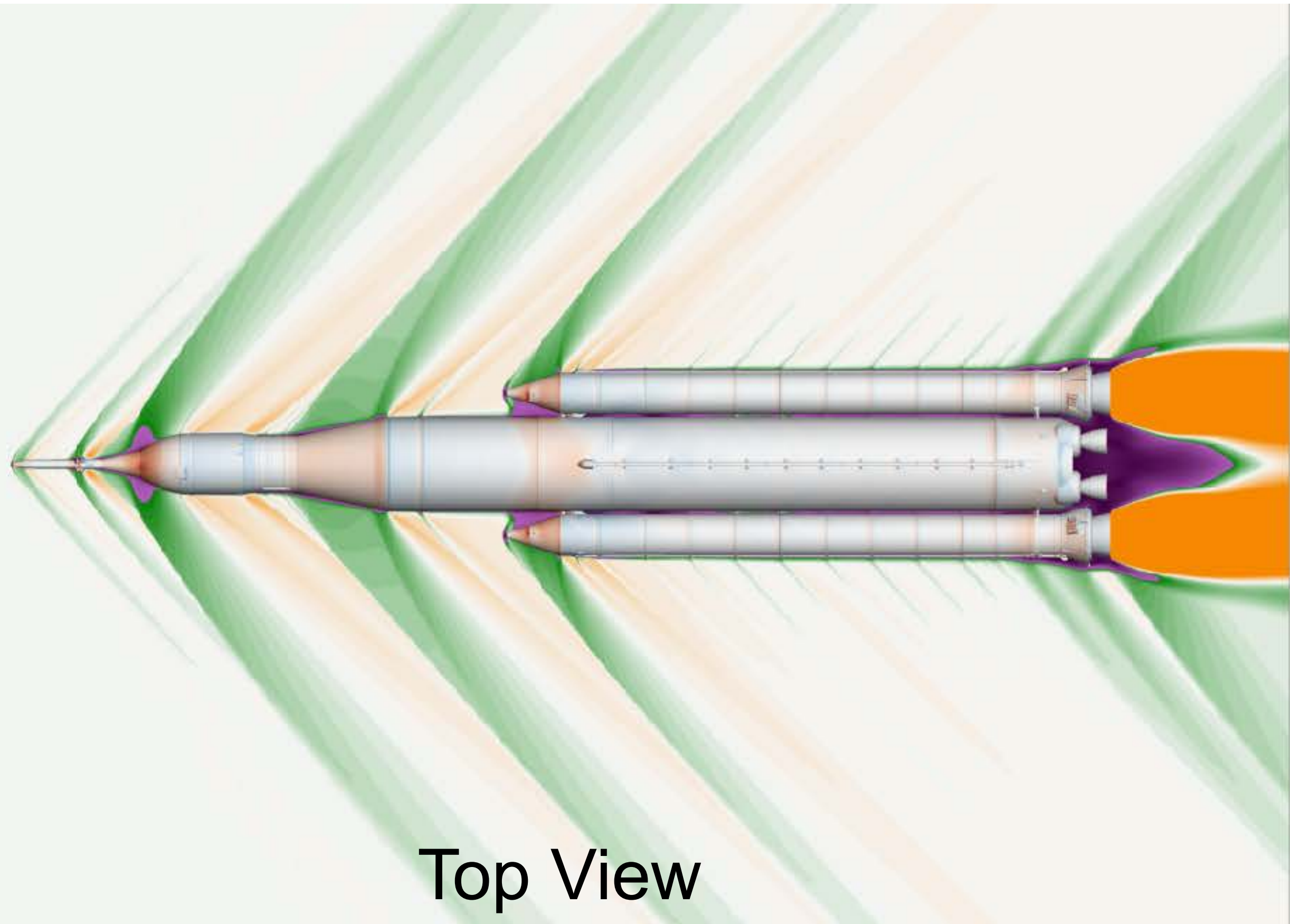

Background slice purple-green-white-orange color contours represent low to high velocities
Vehicle surface blue-white-red color contours represent low to high pressures

SLS Block 1 Crew Ascent

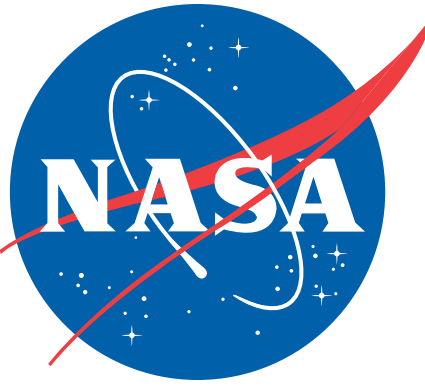

Altitude: Low • • • • • • • • • • High

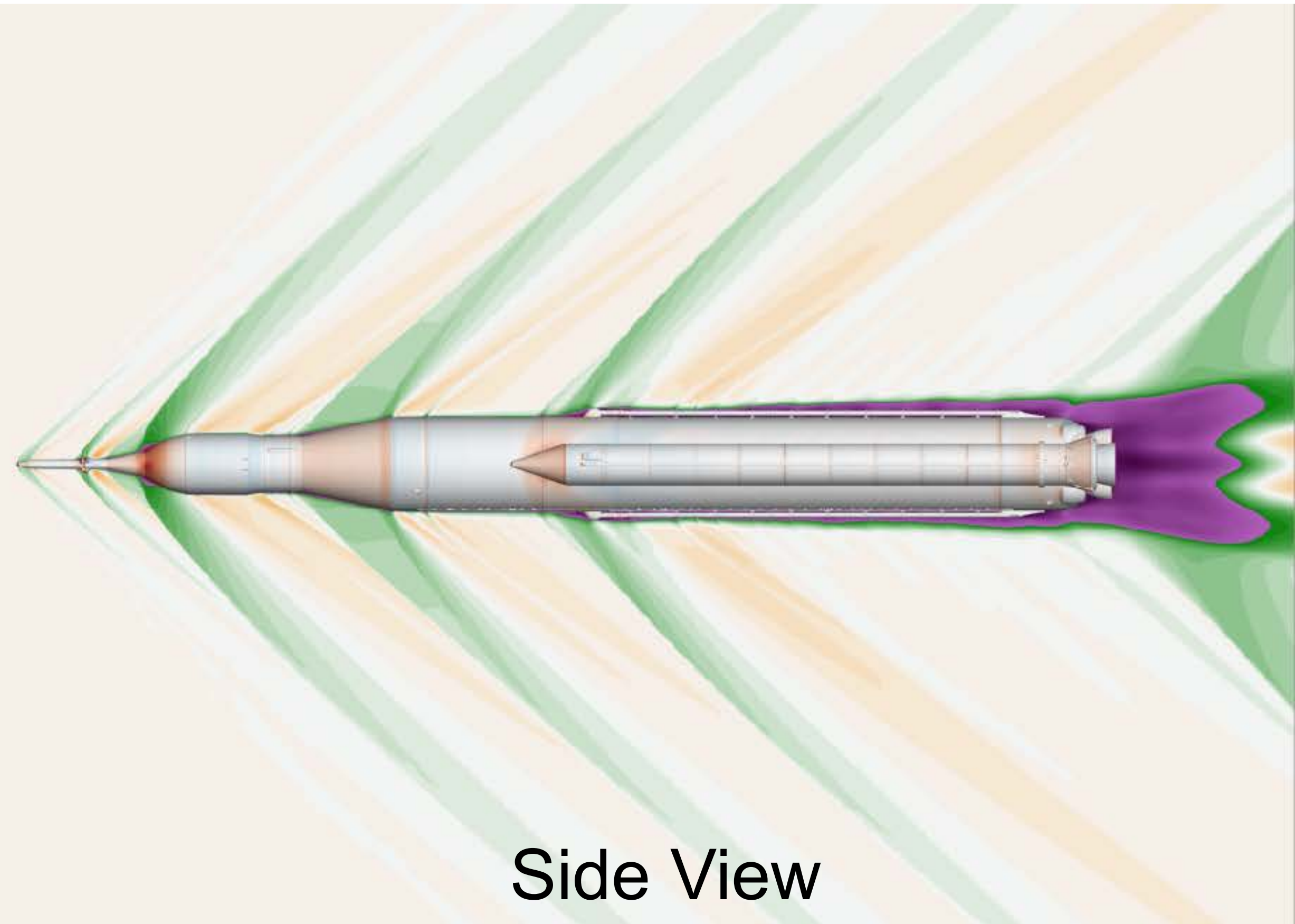
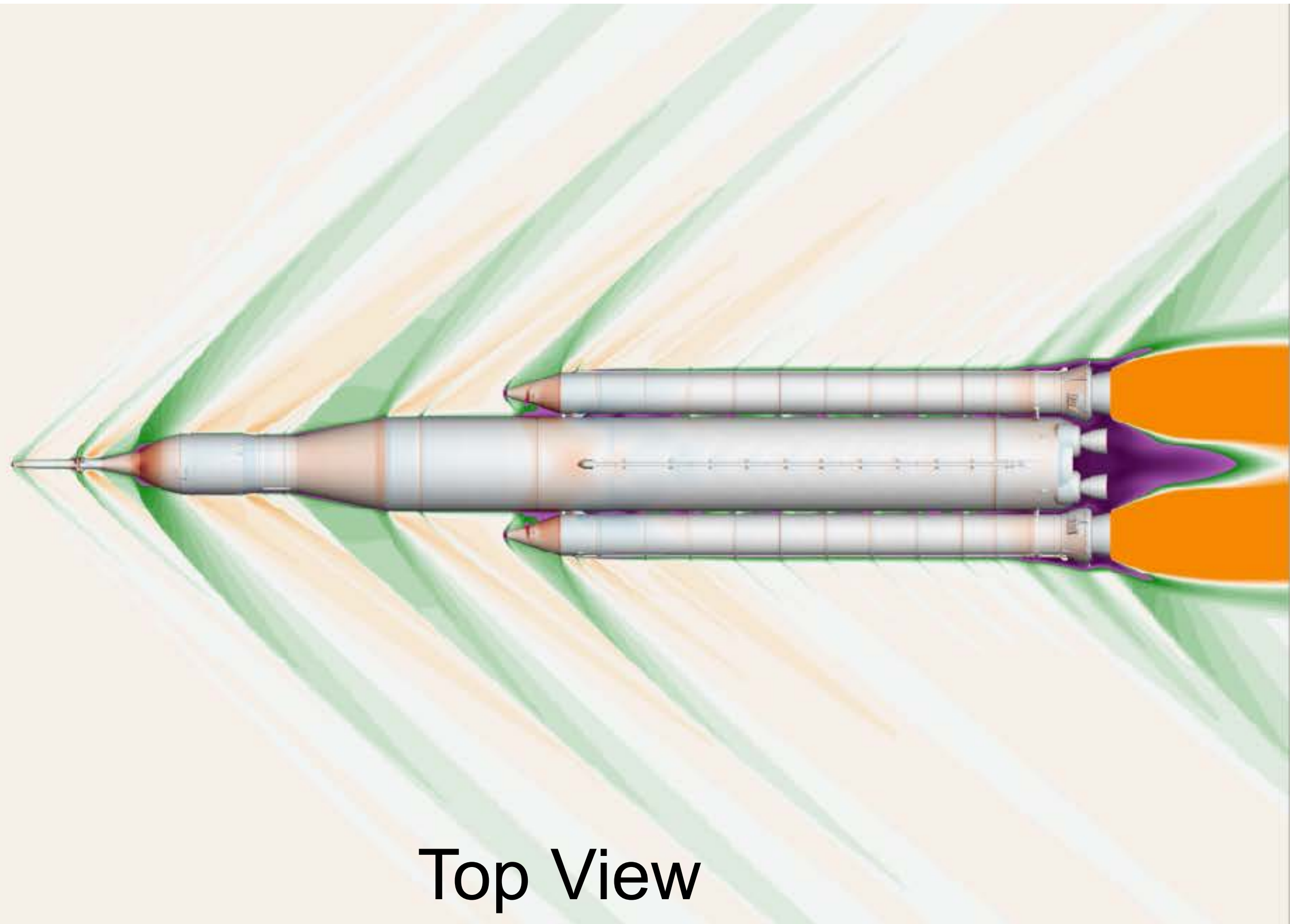

Background slice purple-green-white-orange color contours represent low to high velocities
Vehicle surface blue-white-red color contours represent low to high pressures

SLS Block 1 Crew Ascent

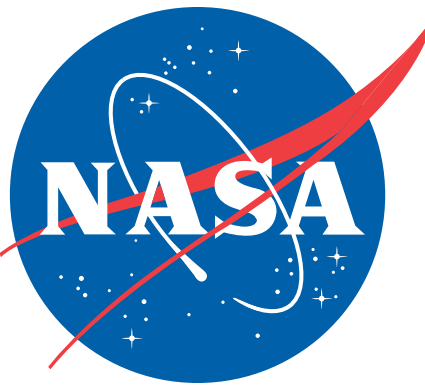

Altitude: Low • • • • • • • • • • High

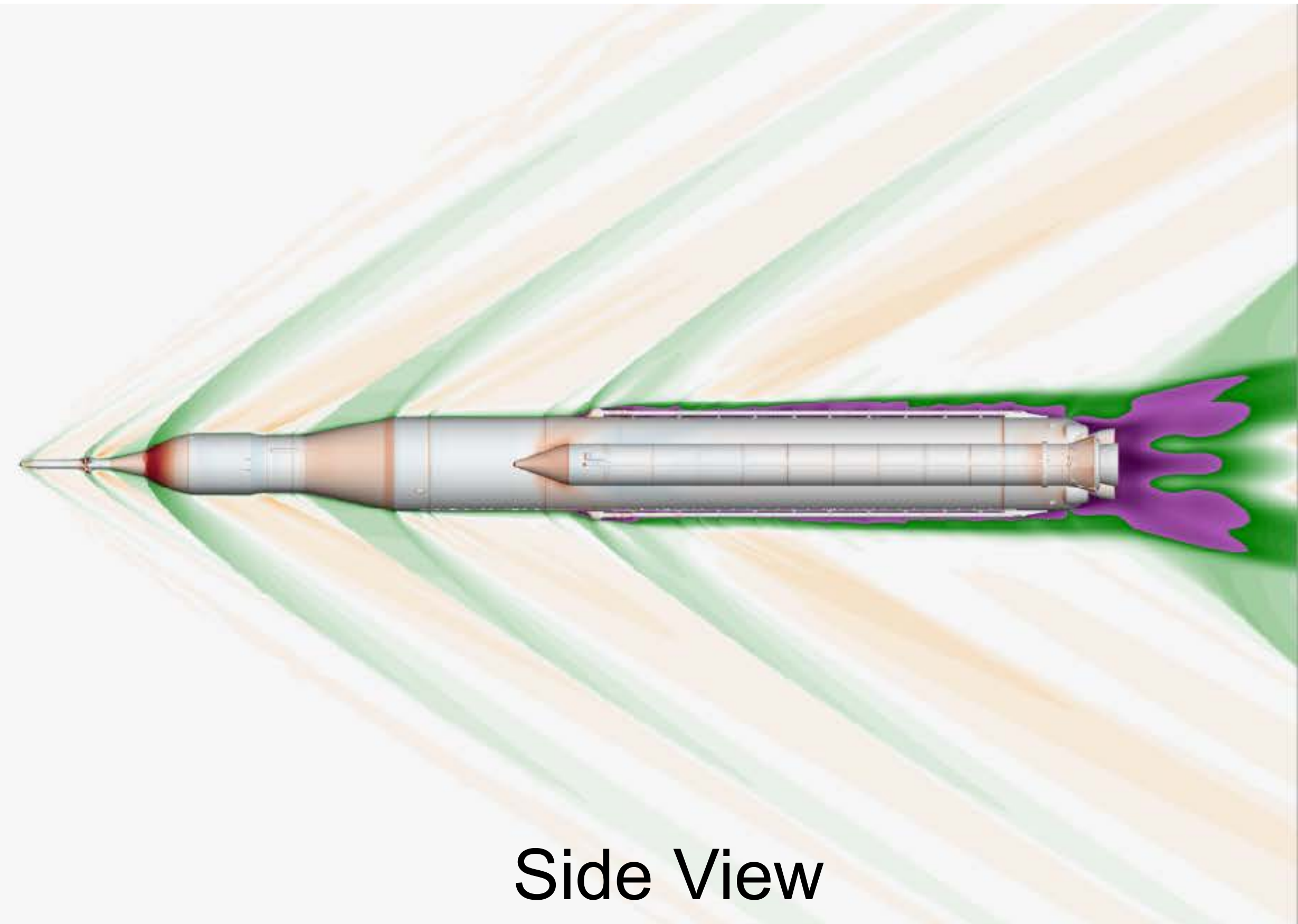
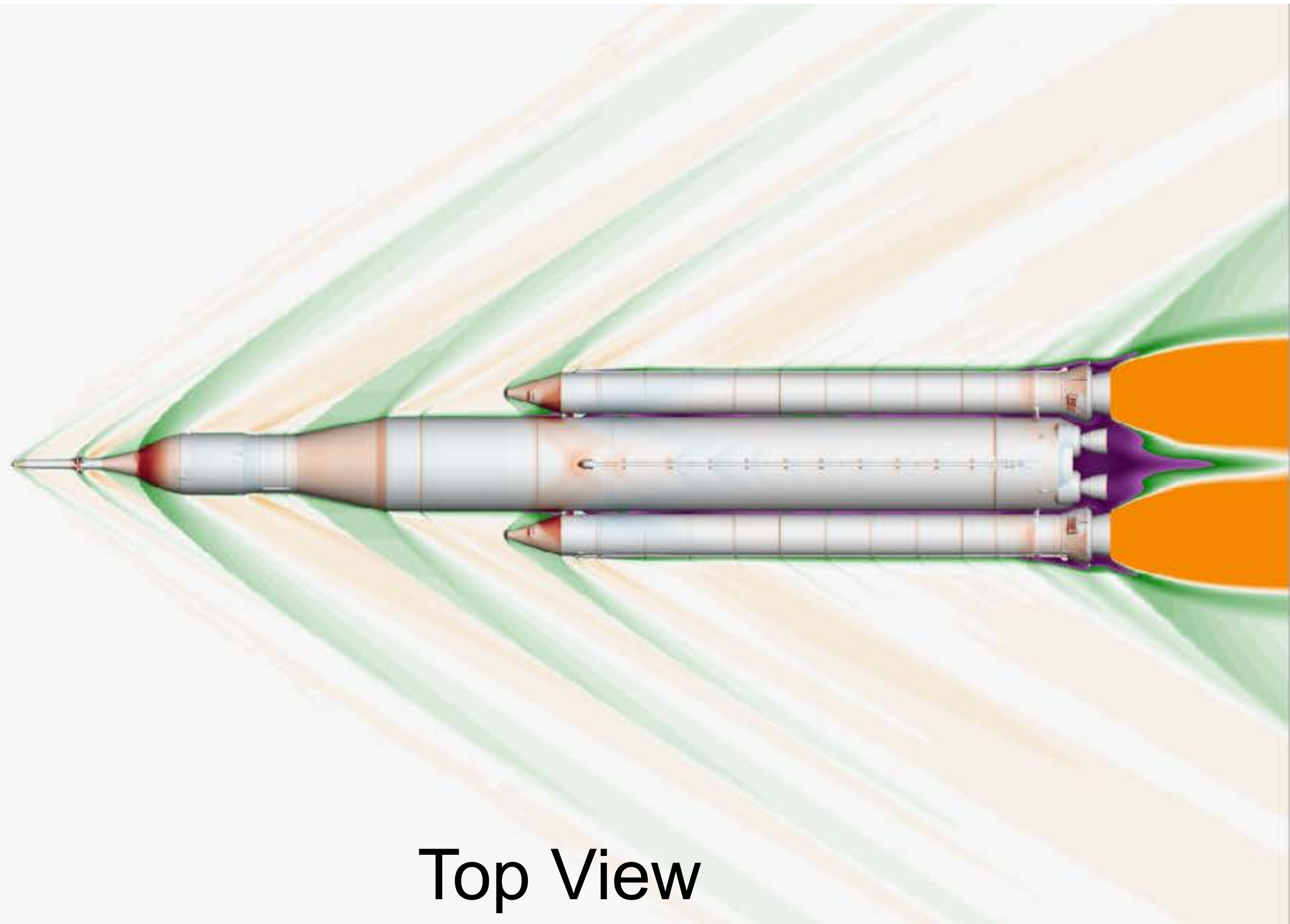

Background slice purple-green-white-orange color contours represent low to high velocities
Vehicle surface blue-white-red color contours represent low to high pressures

SLS Block 1 Crew Ascent

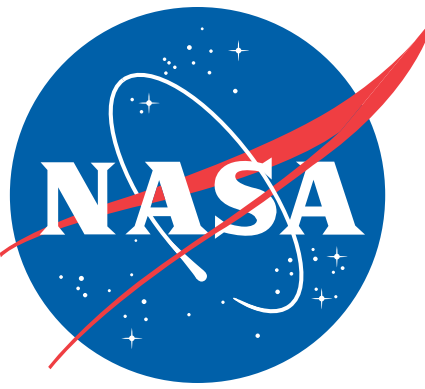

Altitude: Low • • • • • • • • • • High

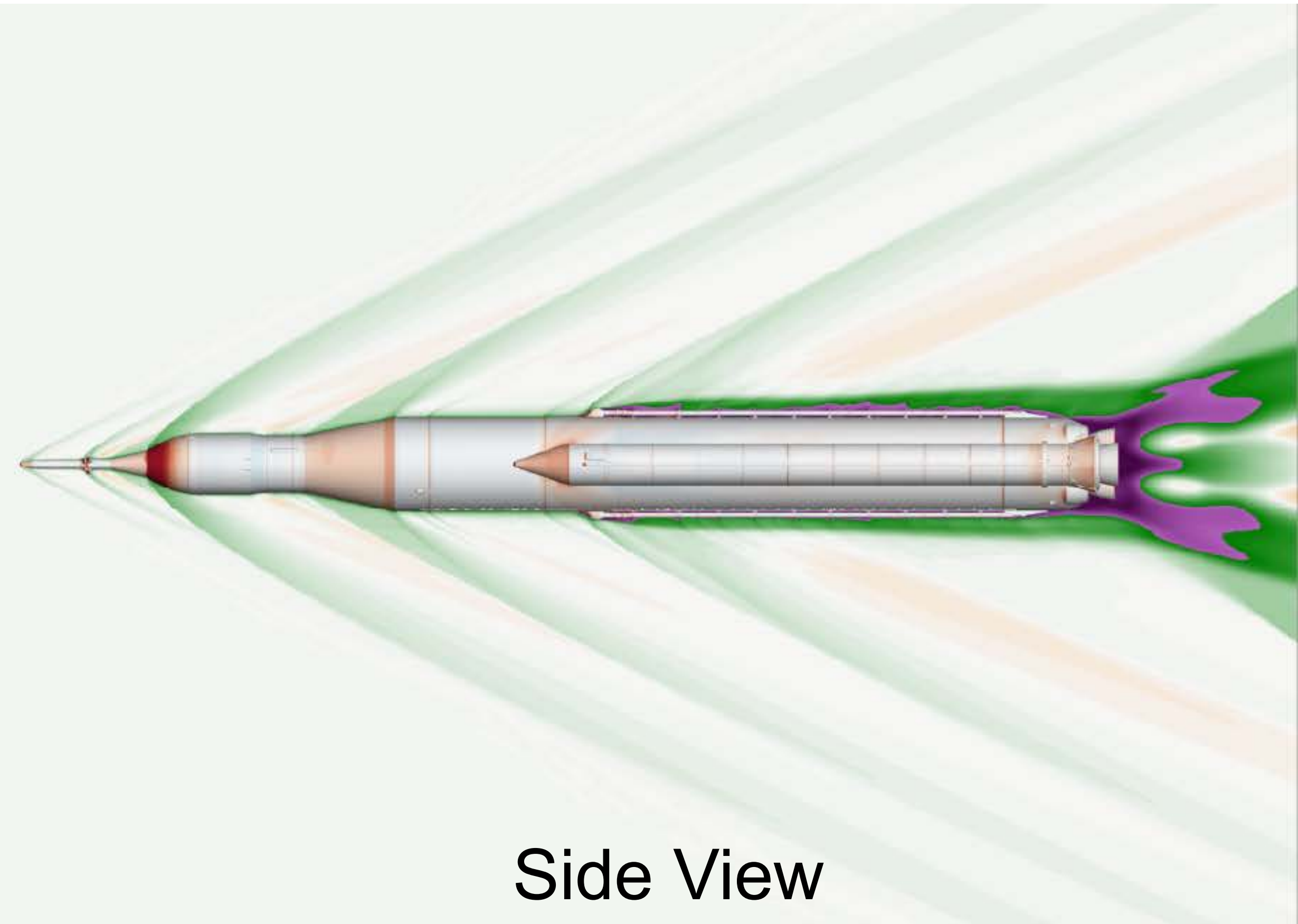
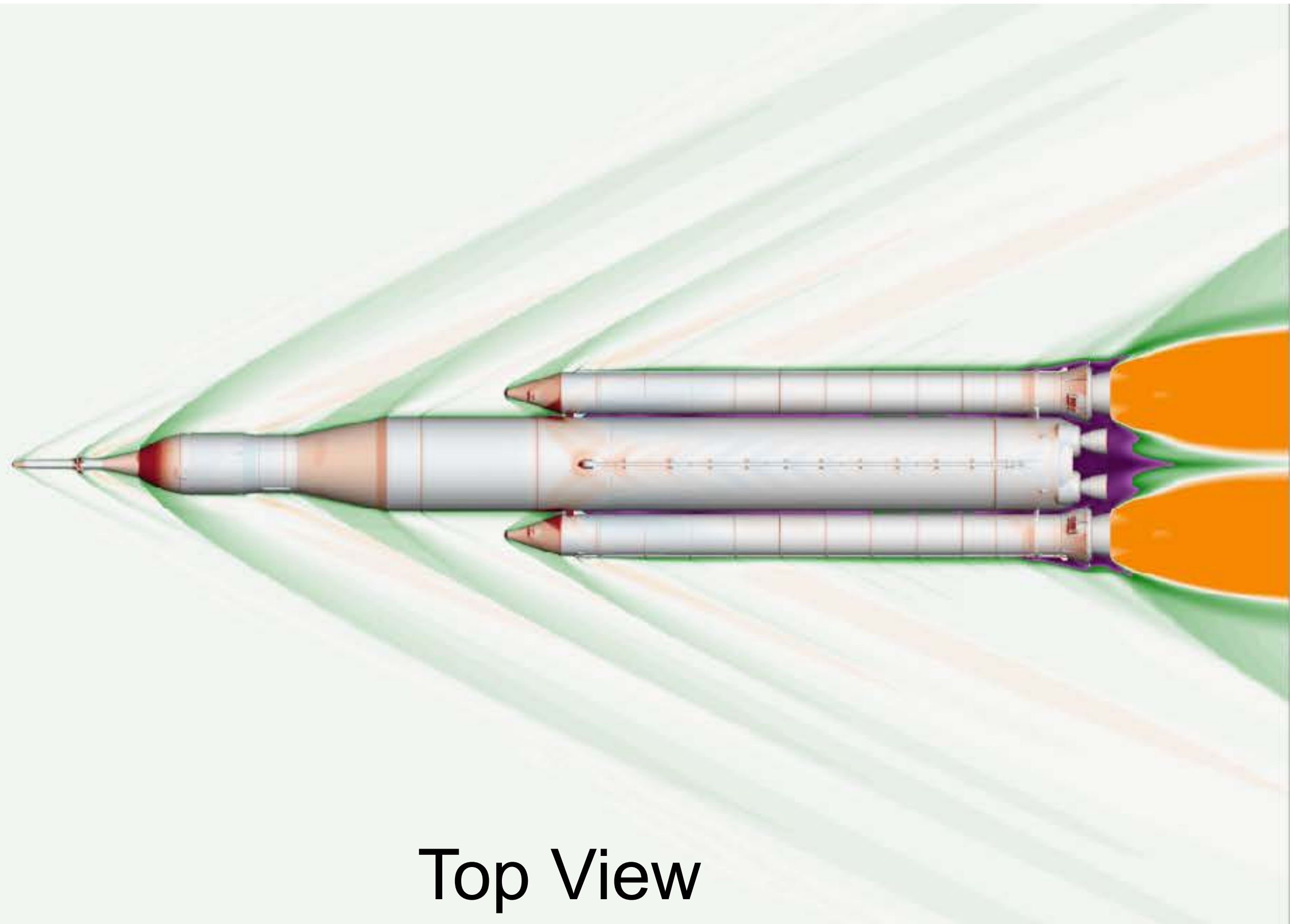

Background slice purple-green-white-orange color contours represent low to high velocities
Vehicle surface blue-white-red color contours represent low to high pressures

SLS Block 1 Crew Ascent

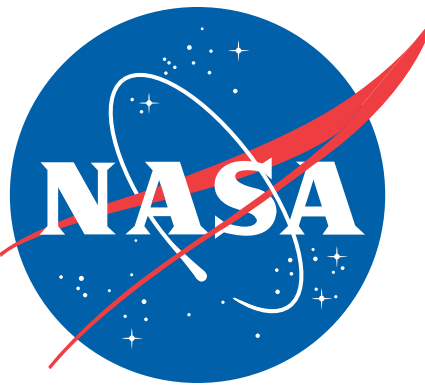

Altitude: Low • • • • • • • • • • High

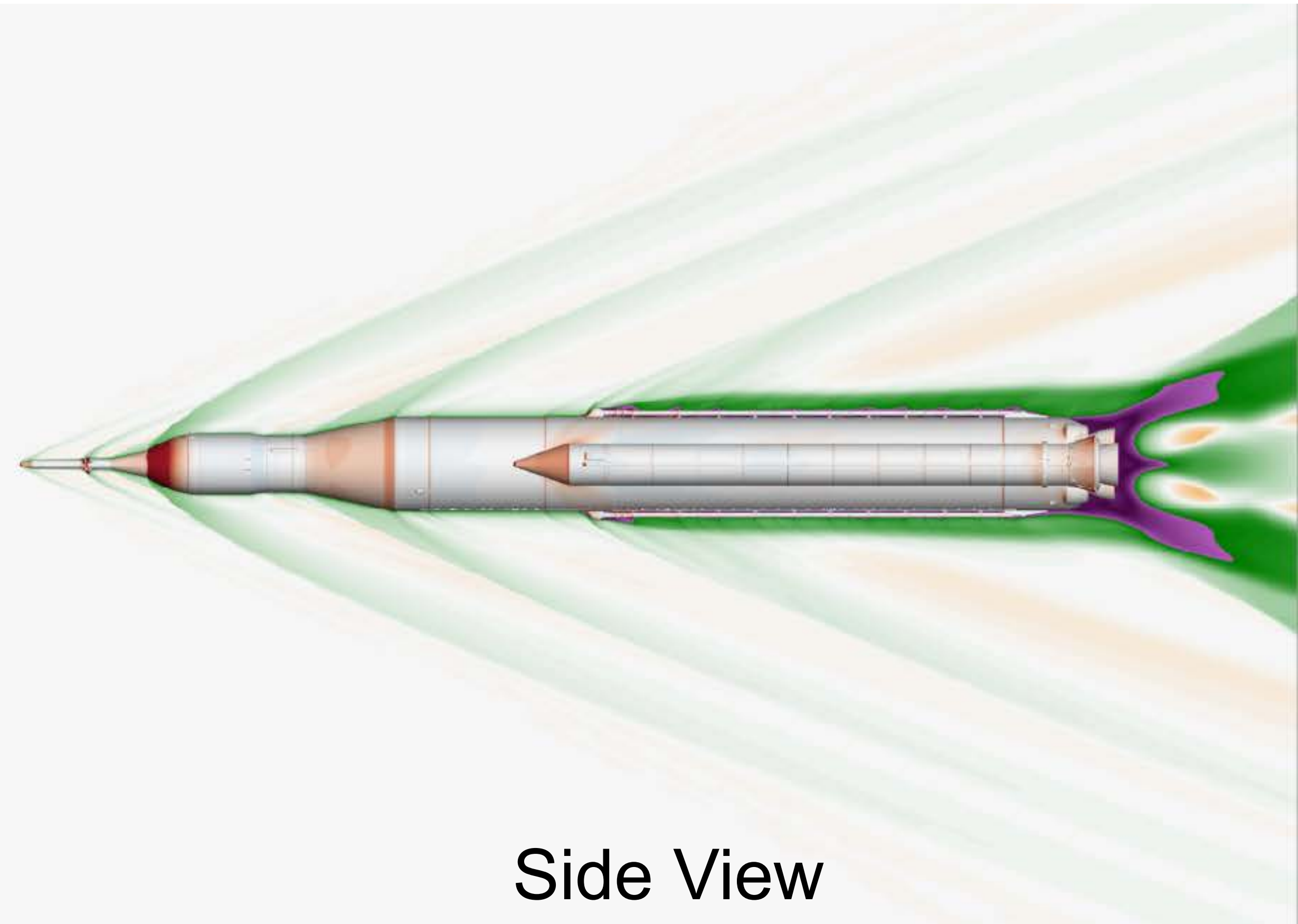
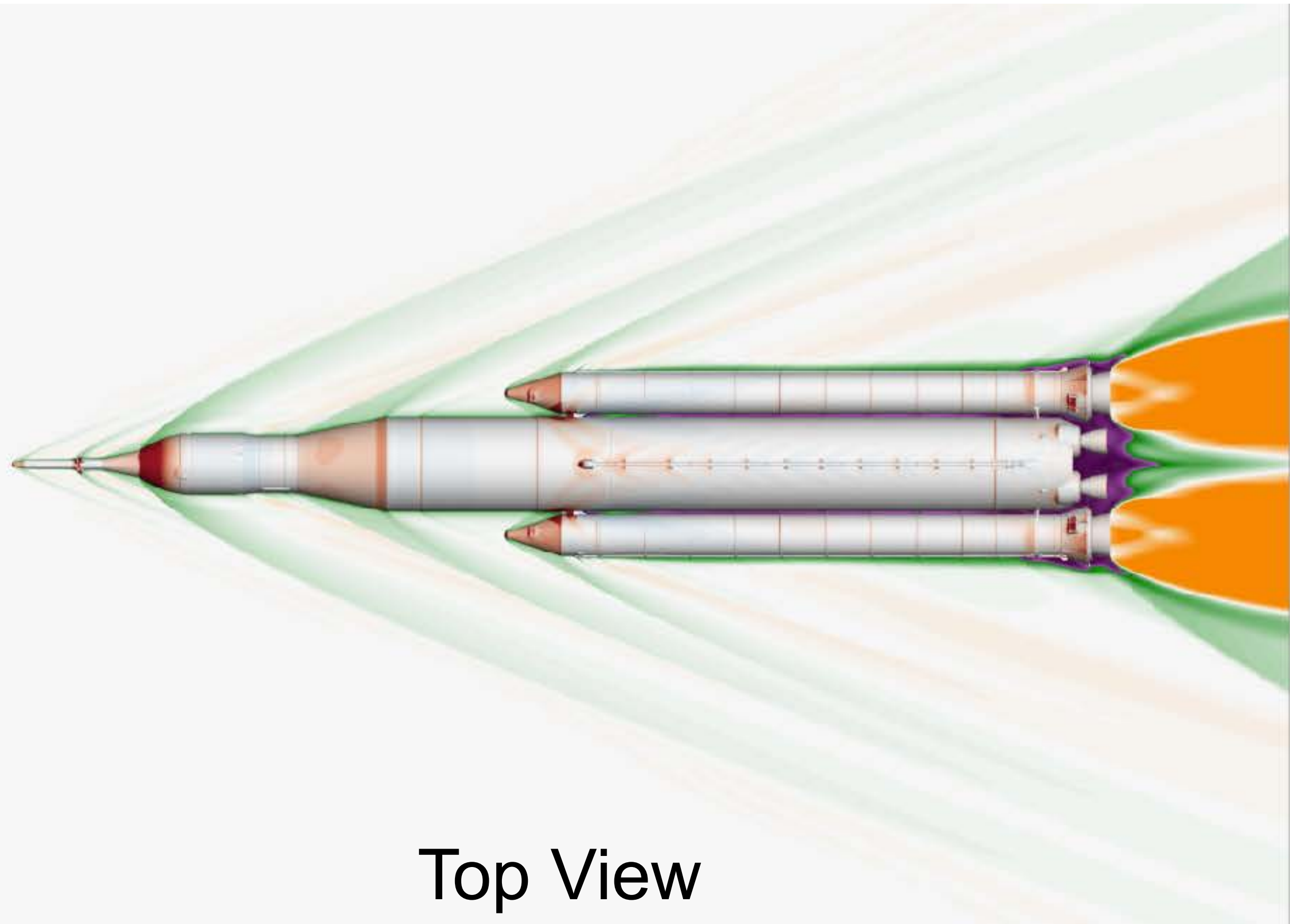

Background slice purple-green-white-orange color contours represent low to high velocities
Vehicle surface blue-white-red color contours represent low to high pressures

SLS Block 1 Crew Ascent

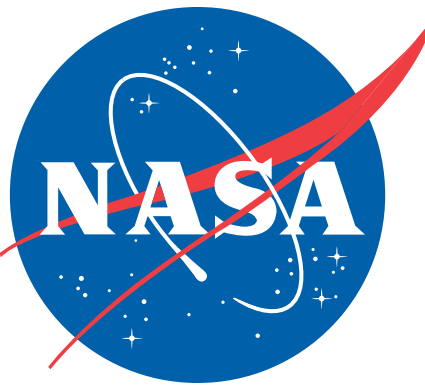

Altitude: Low • • • • • • • • • • High

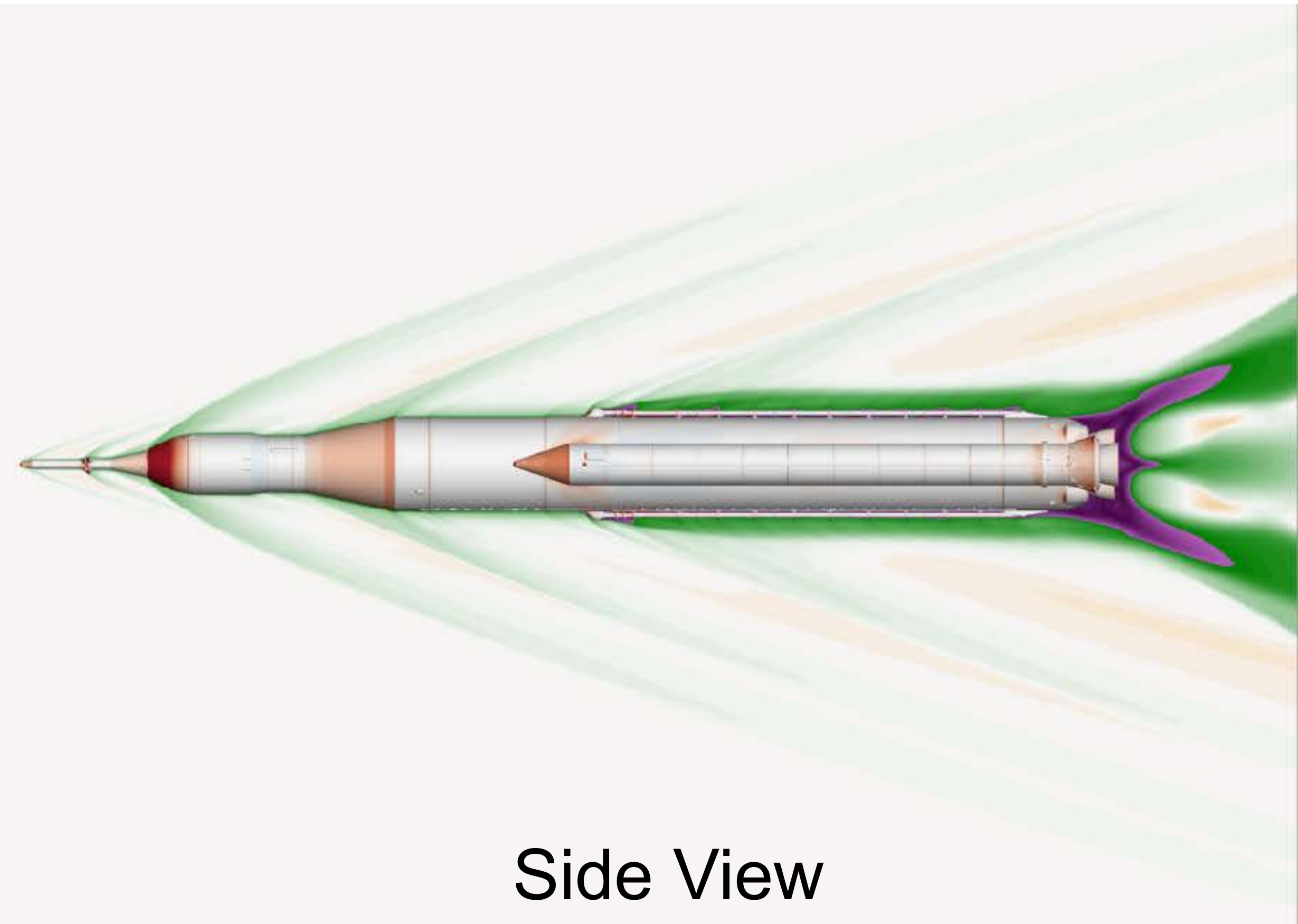
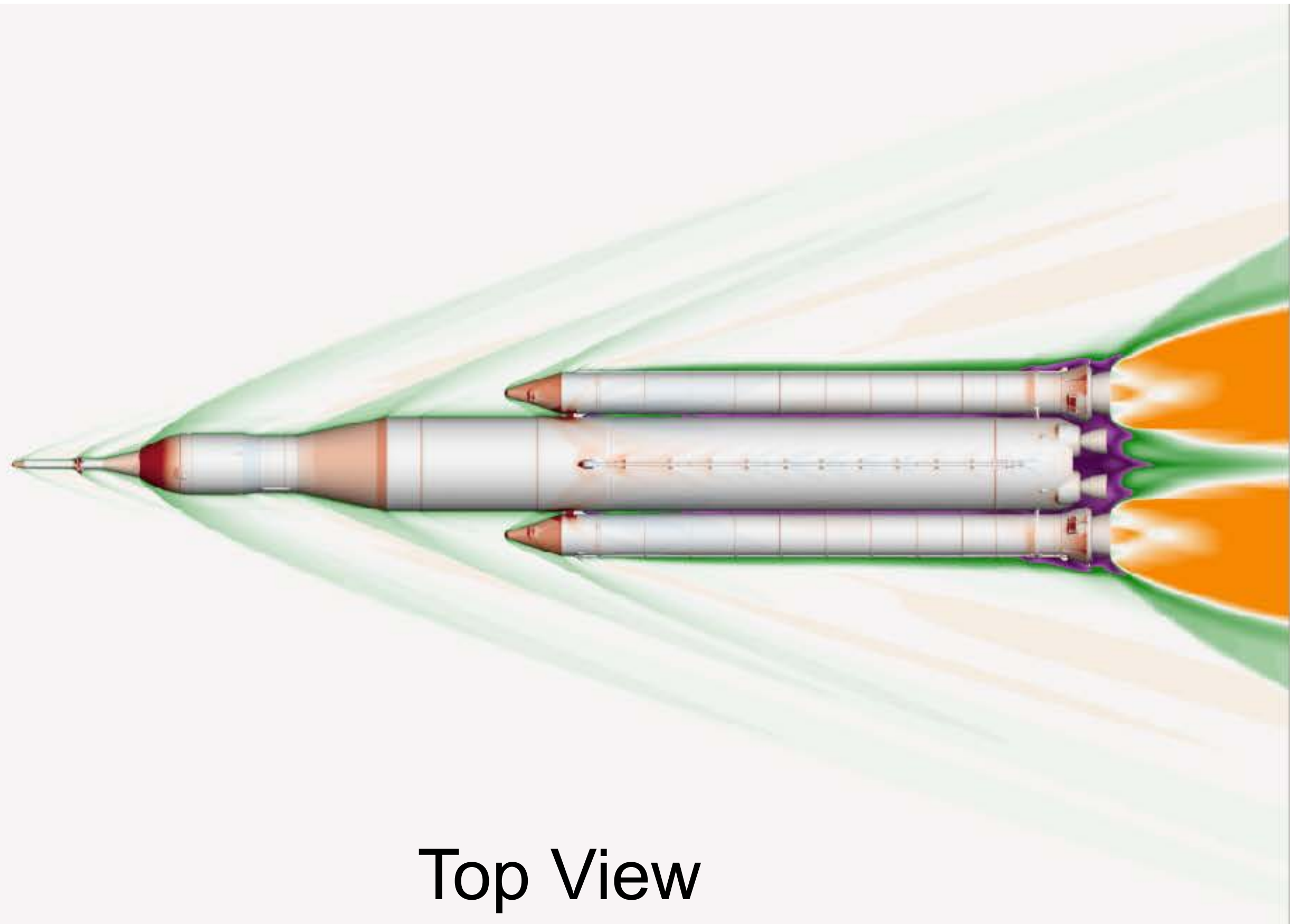

Background slice purple-green-white-orange color contours represent low to high velocities
Vehicle surface blue-white-red color contours represent low to high pressures

SLS Block 1 Crew Ascent

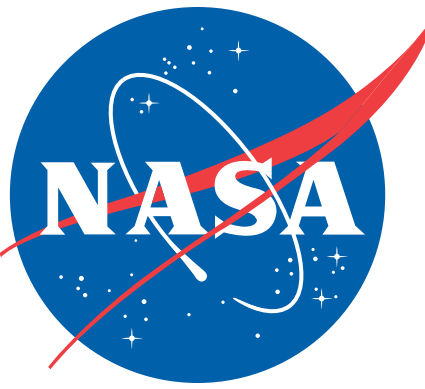

Altitude: Low • • • • • • • • • • High

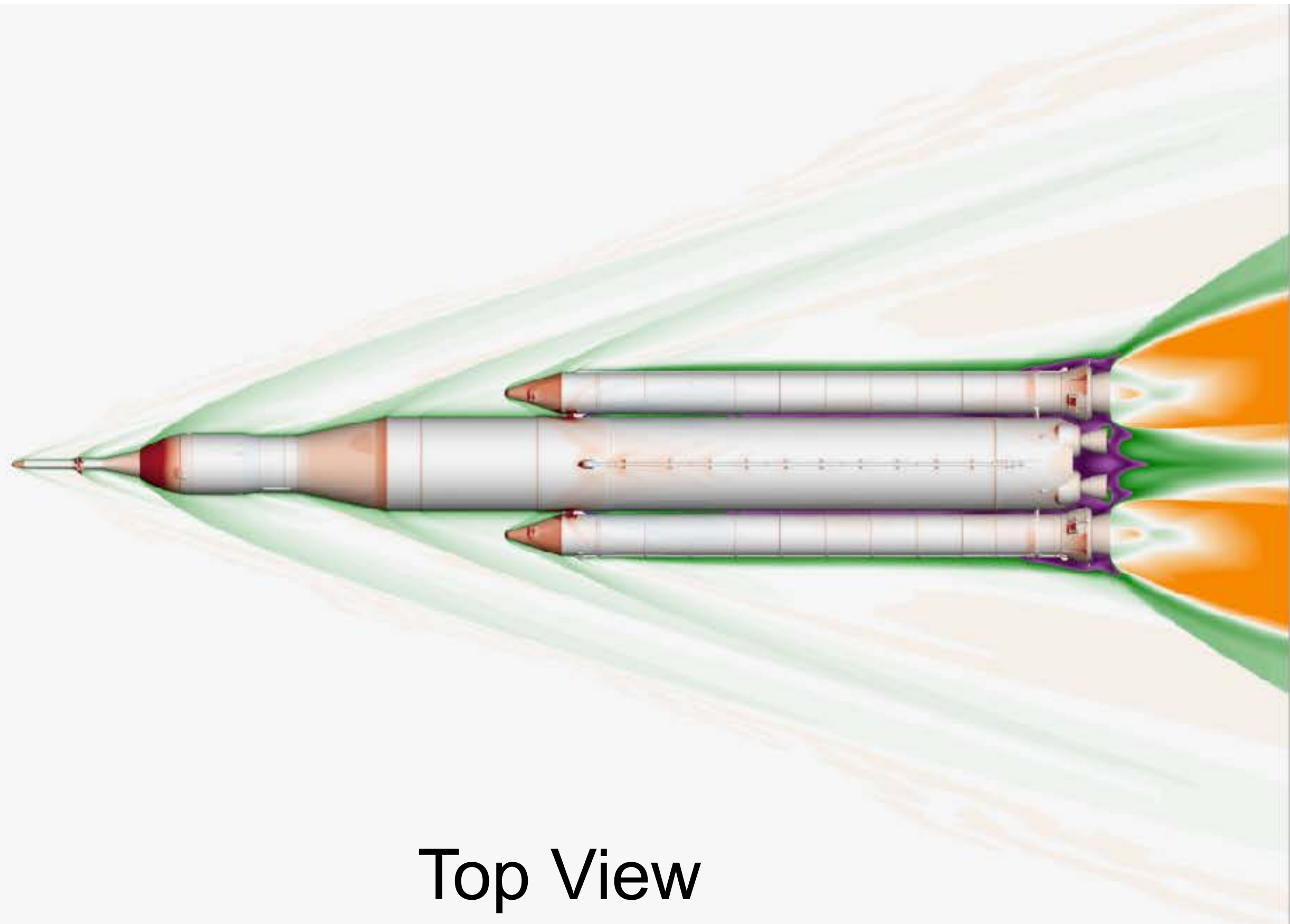

Top View

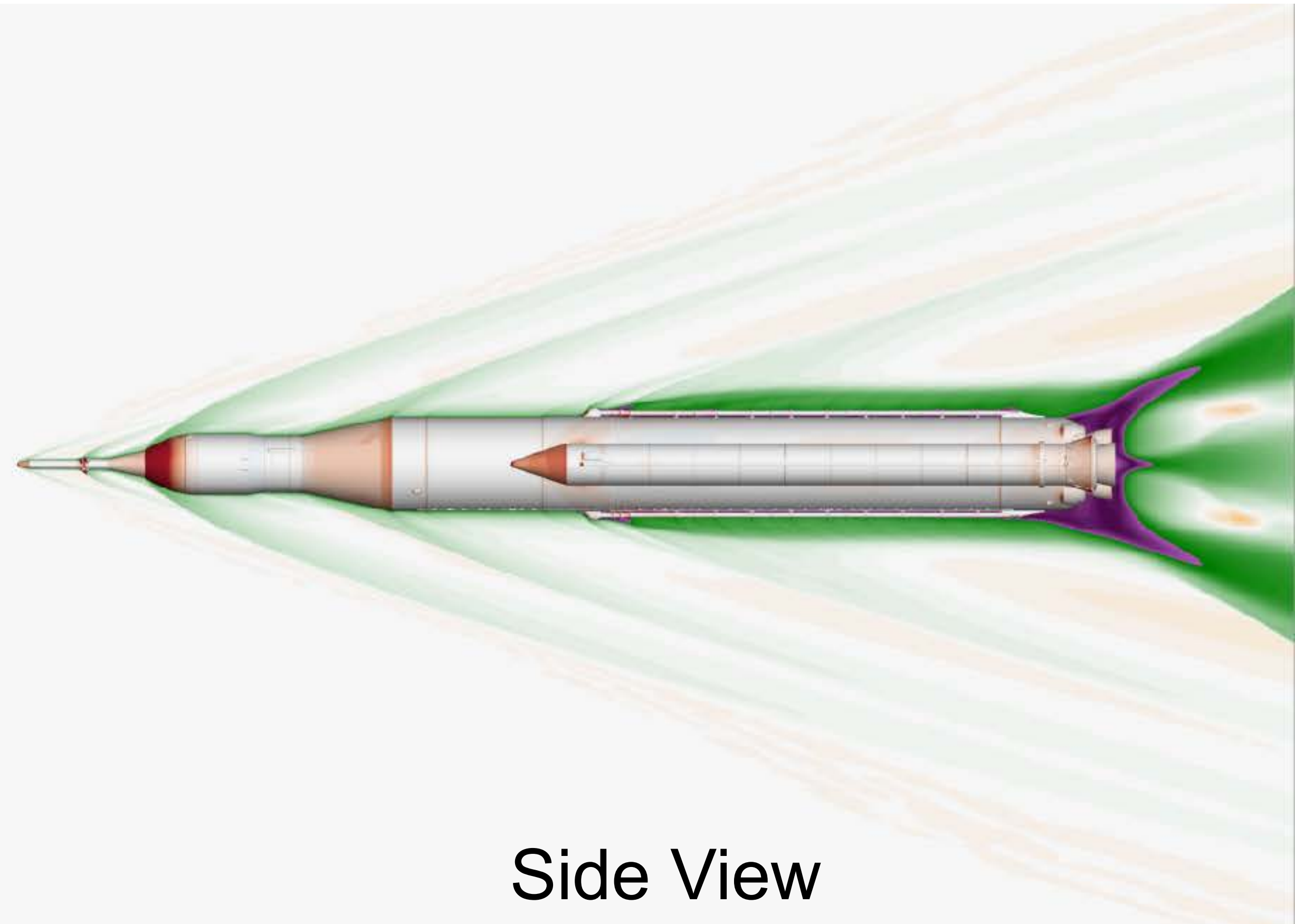

Side View

Background slice purple-green-white-orange color contours represent low to high velocities
Vehicle surface blue-white-red color contours represent low to high pressures

SLS Block 1 Crew Ascent

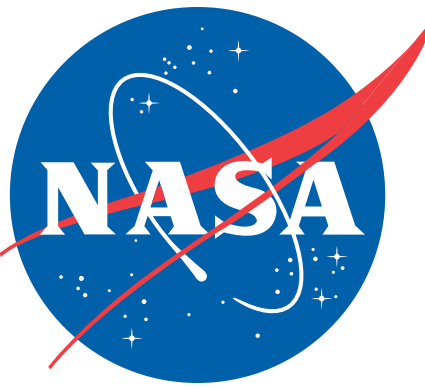

Altitude: Low • • • • • • • • • • High

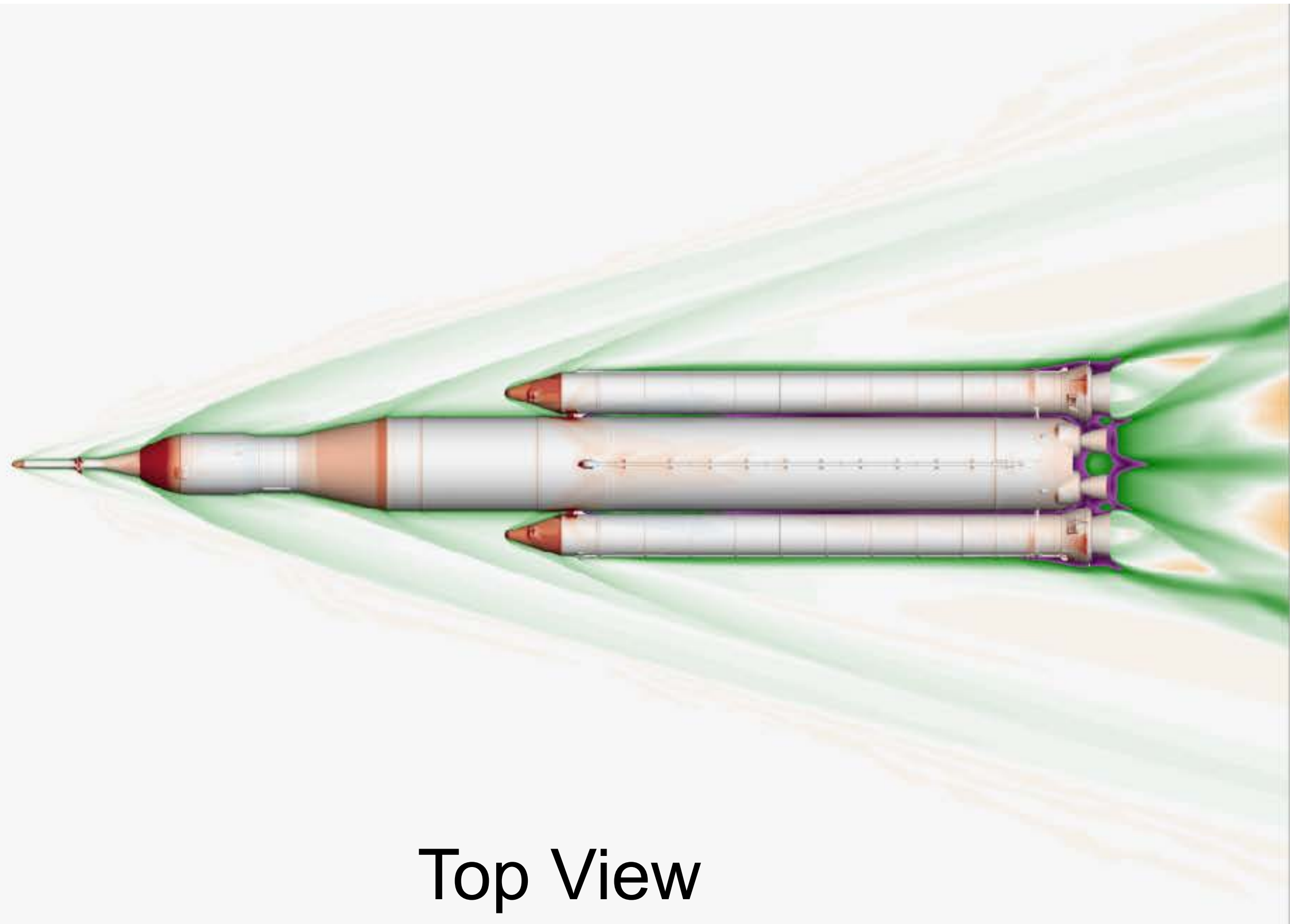

Top View

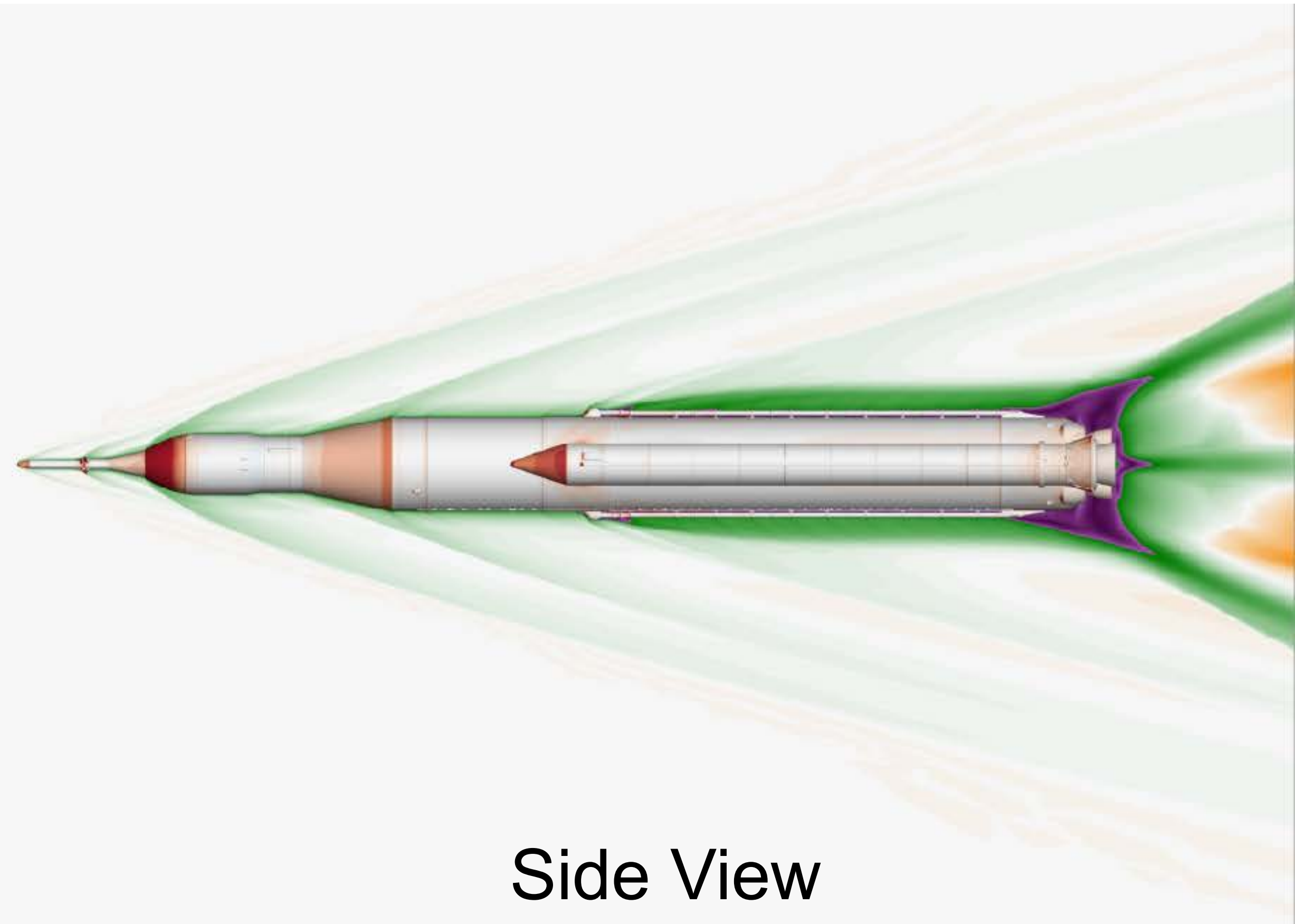

Side View

Background slice purple-green-white-orange color contours represent low to high velocities
Vehicle surface blue-white-red color contours represent low to high pressures

SLS Block 1 Crew Ascent

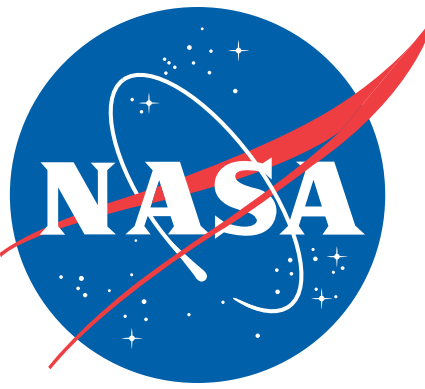

Altitude: Low • • • • • • • • • • High

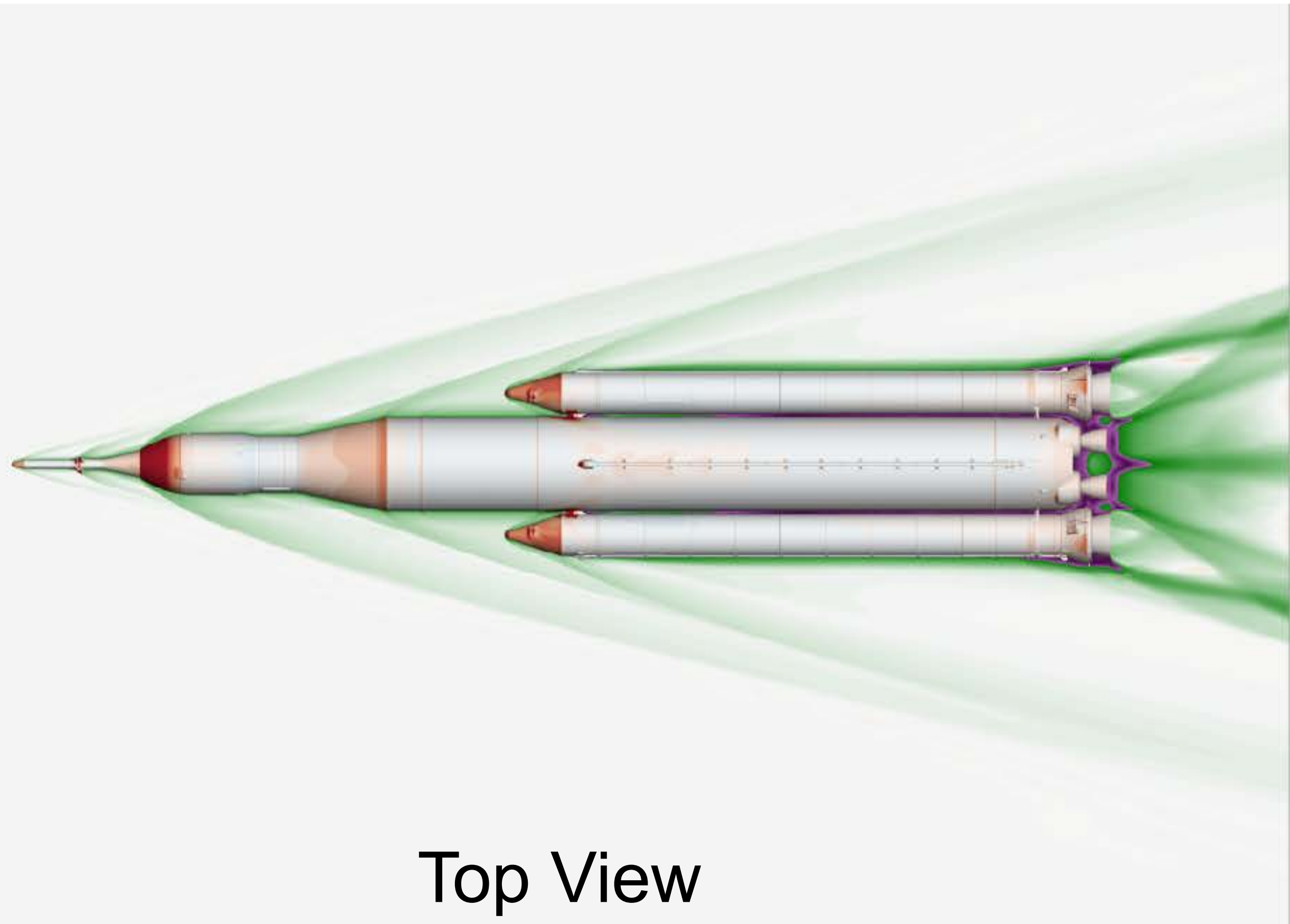

Top View

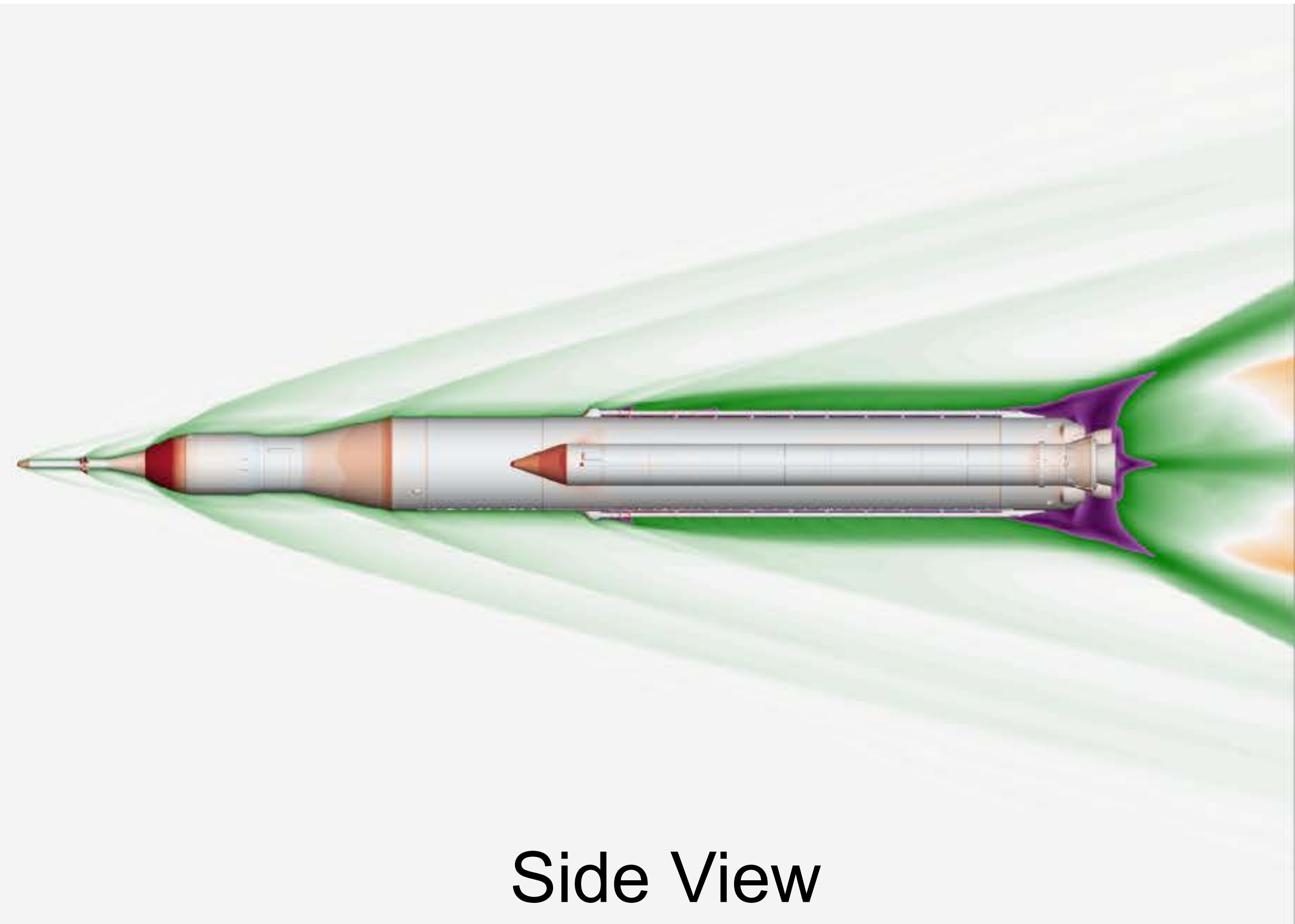

Side View

Background slice purple-green-white-orange color contours represent low to high velocities
Vehicle surface blue-white-red color contours represent low to high pressures

SLS Block 1 Booster Separation

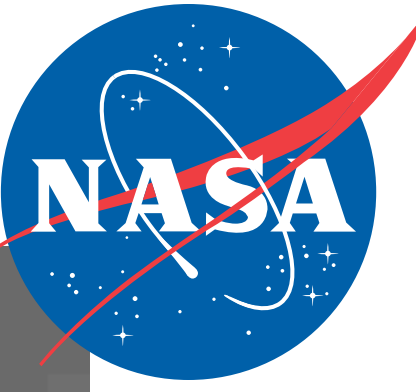

Computational Schlieren (by Pat Moran)

SLS Block 1 Booster Separation

Particles Colored by BSM Nozzle
(Pat Moran, Tim Sandstrom)

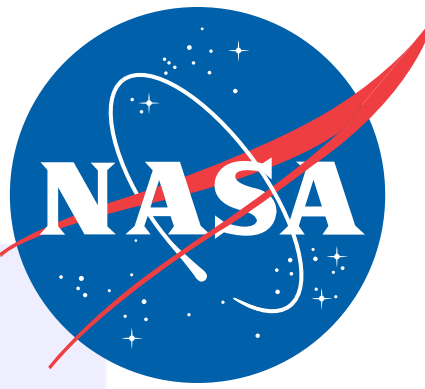

Top View



0' 0"

Iso View

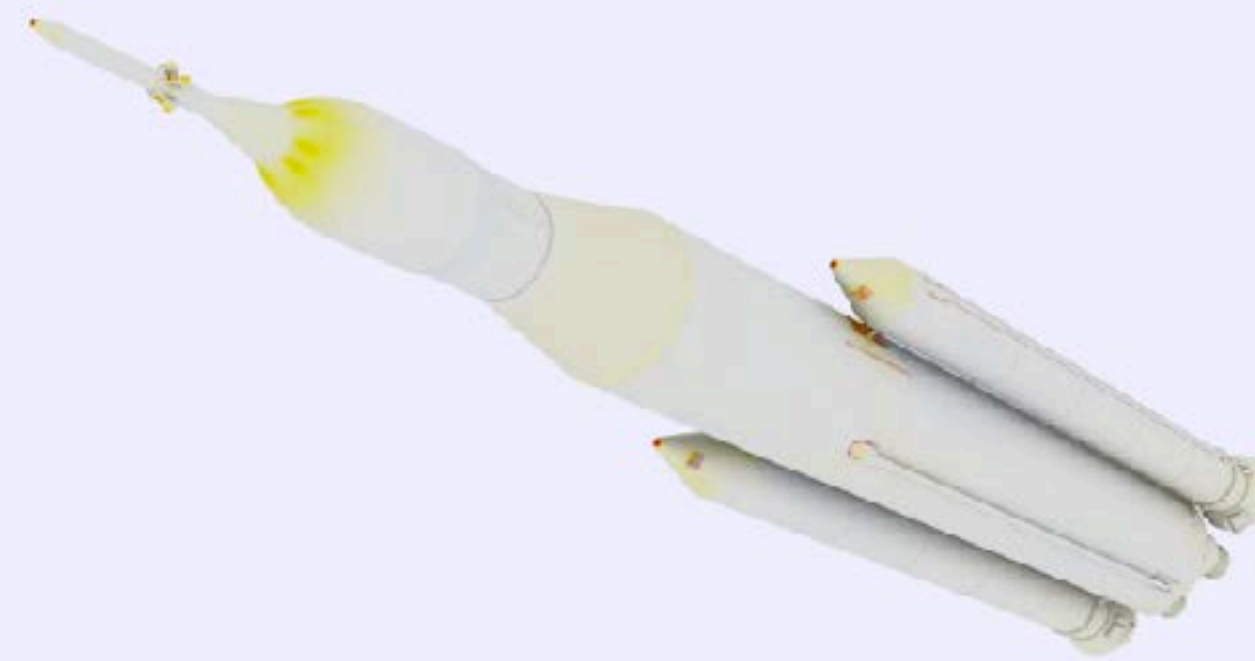

0' 0"

Side View



0' 0"

Side Slice (vorticity)

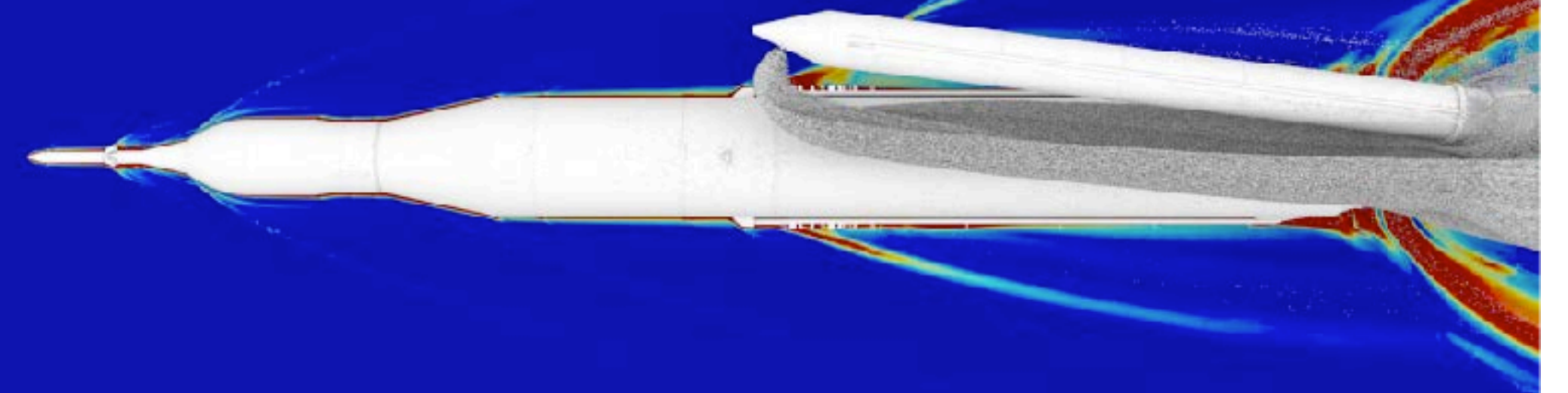

23' 11"

SLS Block 1B Crew Ascent

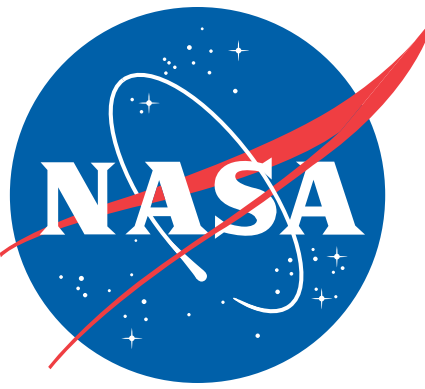

Altitude: Low • • • • • • • • • • • • • • • High

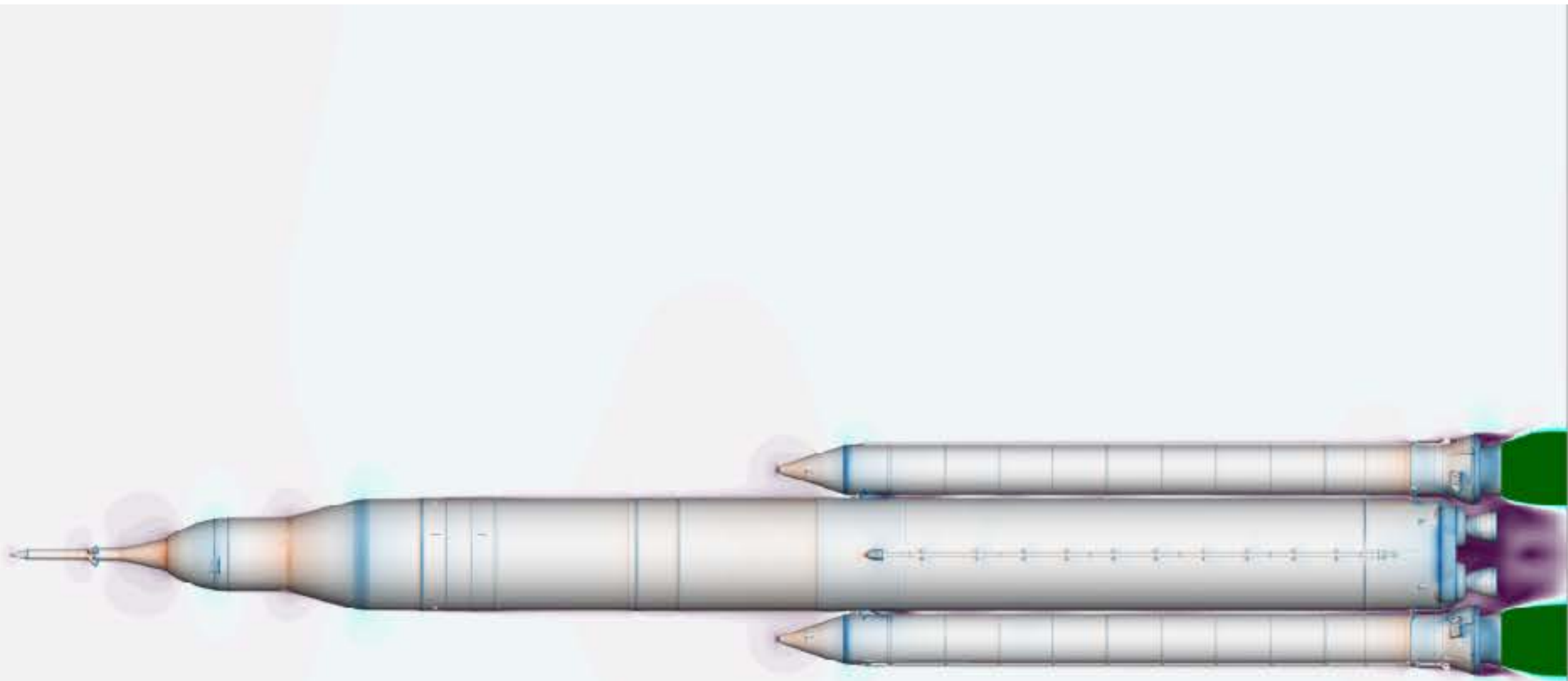

Top View

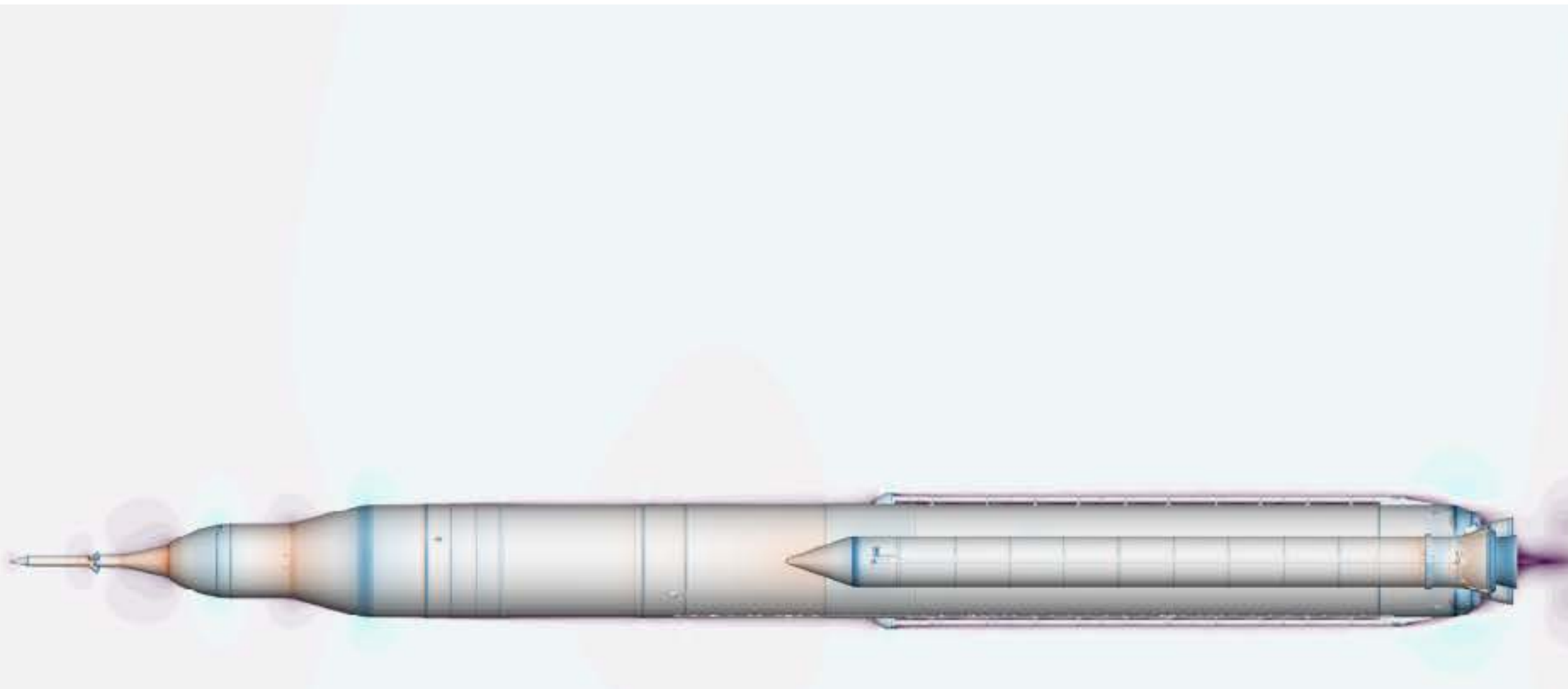

Side View

Background slice purple-green-white-orange color contours represent low to high velocities
Vehicle surface blue-white-red color contours represent low to high pressures

SLS Block 1B Crew Ascent

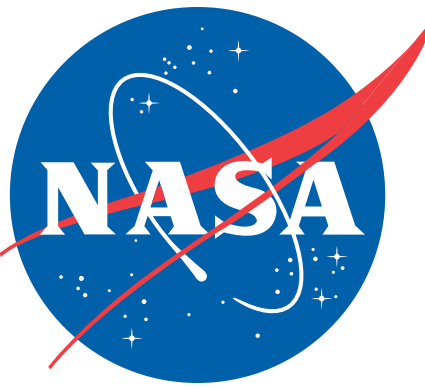

Altitude: Low • • • • • • • • • • • • • • • • High

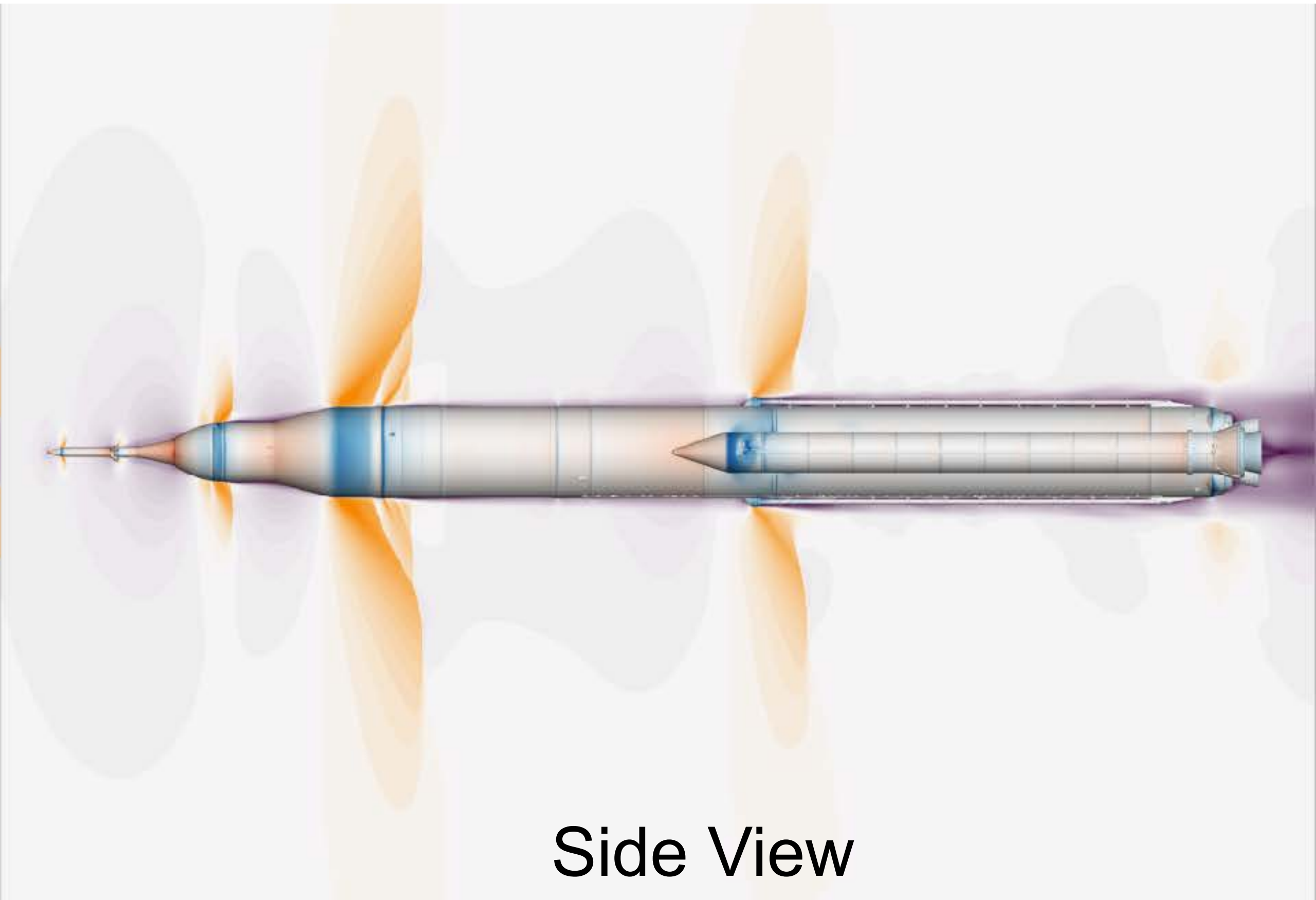
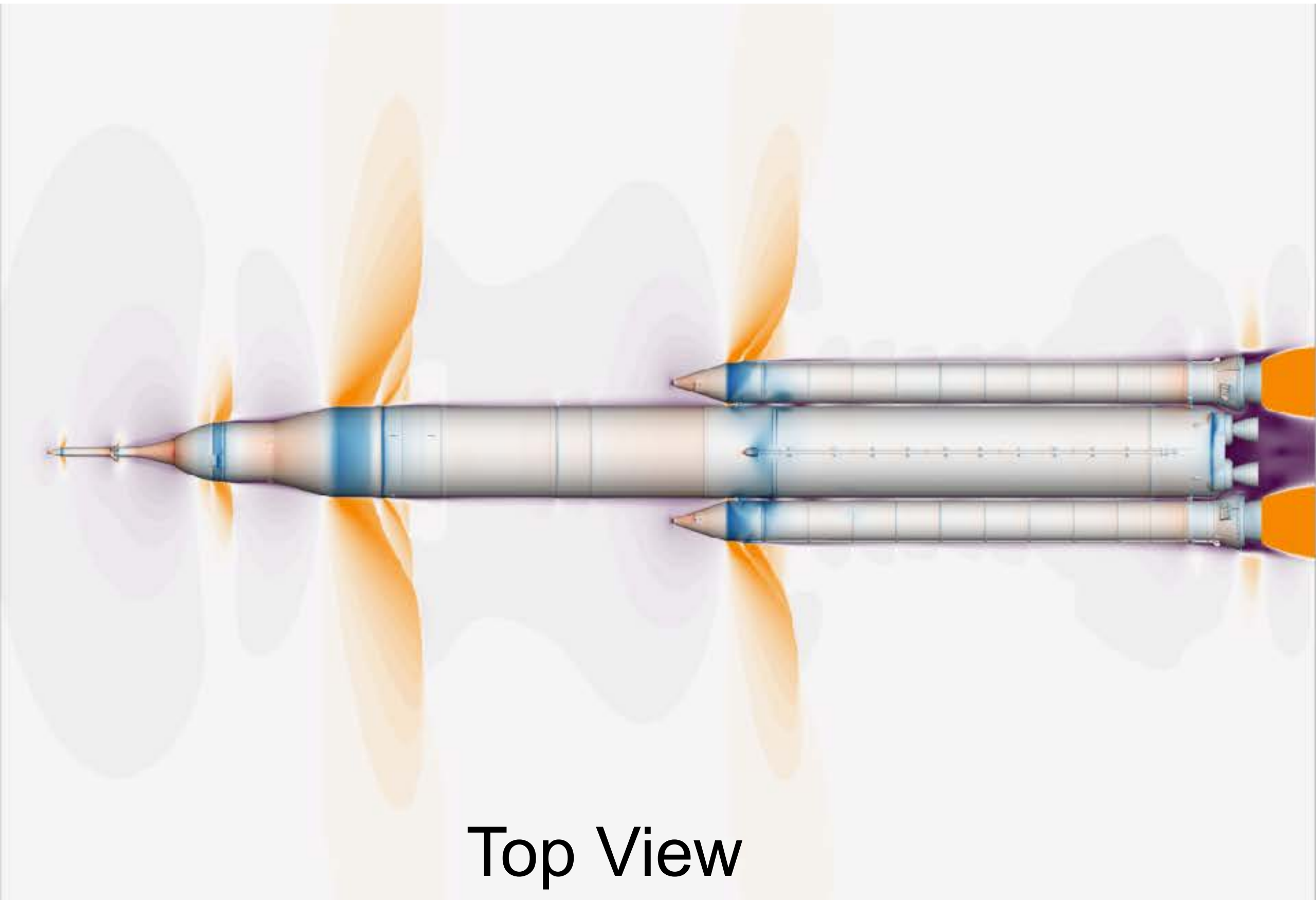

Background slice purple-green-white-orange color contours represent low to high velocities
Vehicle surface blue-white-red color contours represent low to high pressures

SLS Block 1B Crew Ascent

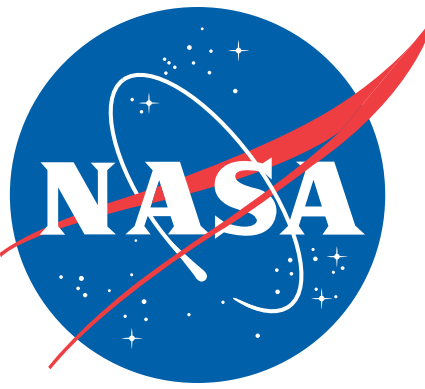

Altitude: Low • • • • • • • • • • • • • • • • • • High

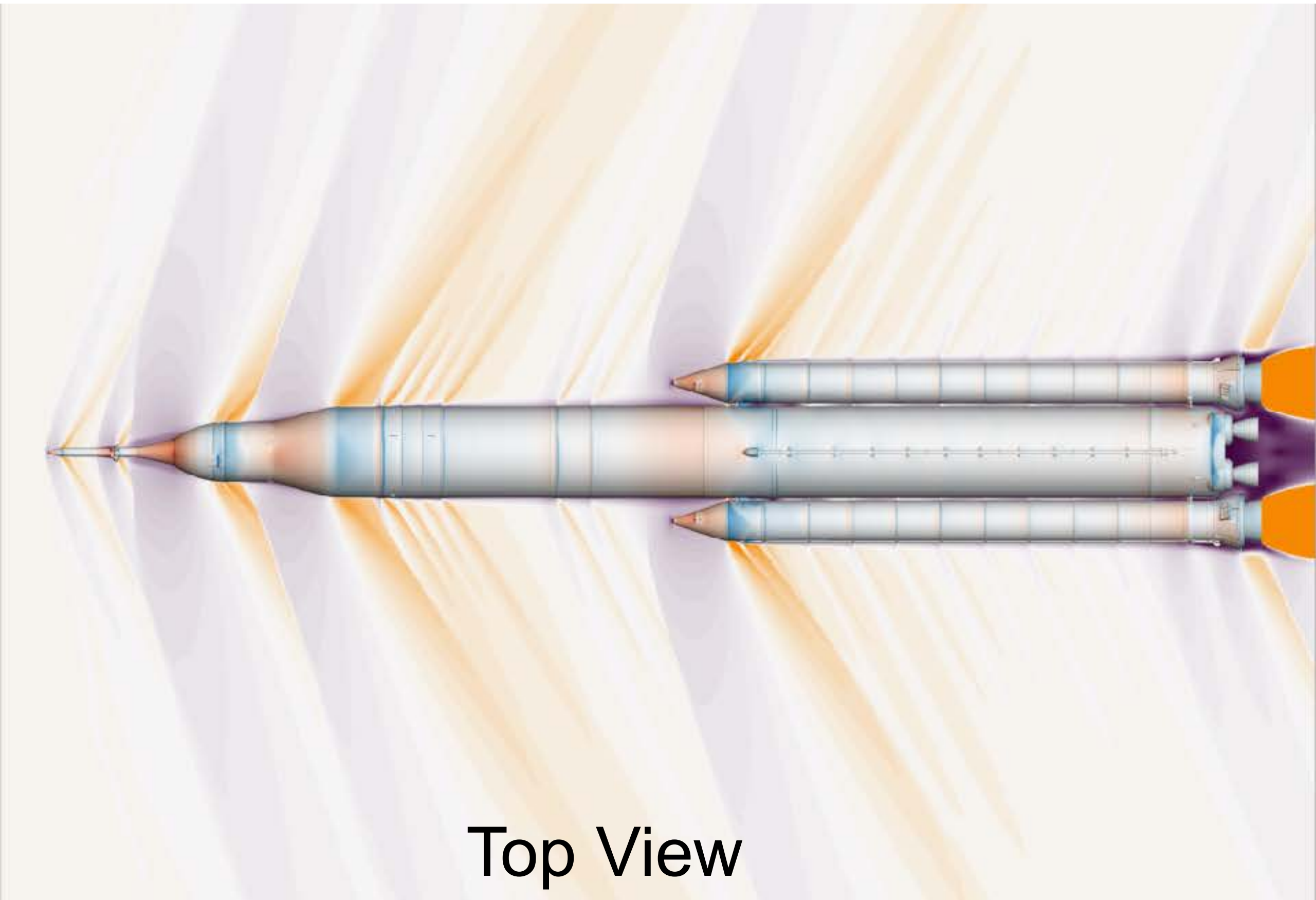

Top View

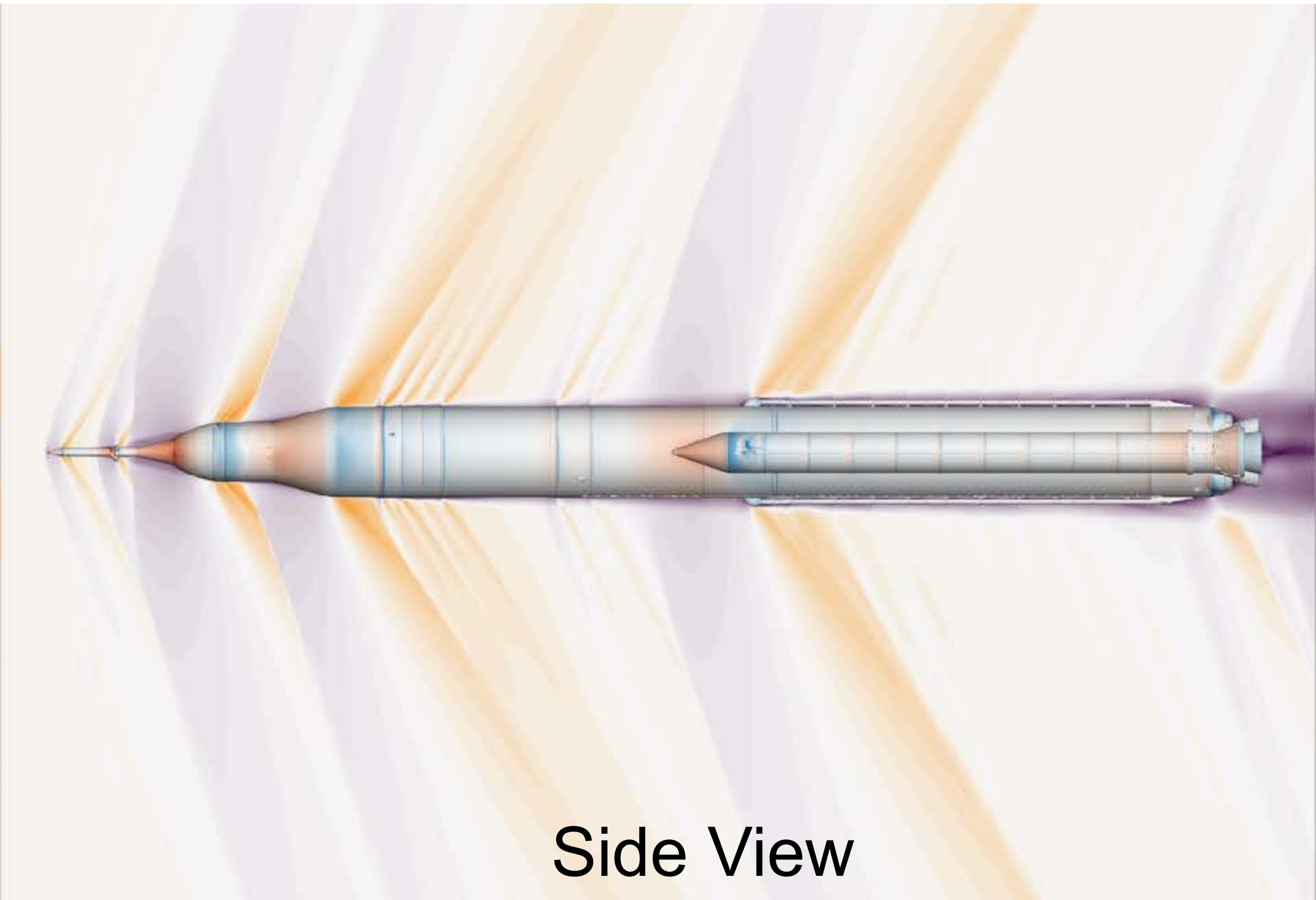

Side View

Background slice purple-green-white-orange color contours represent low to high velocities
Vehicle surface blue-white-red color contours represent low to high pressures

SLS Block 1B Crew Booster Separation

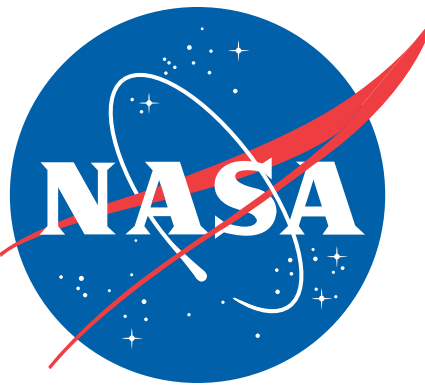

Booster Proximity: Attached • • • • • • • Separated

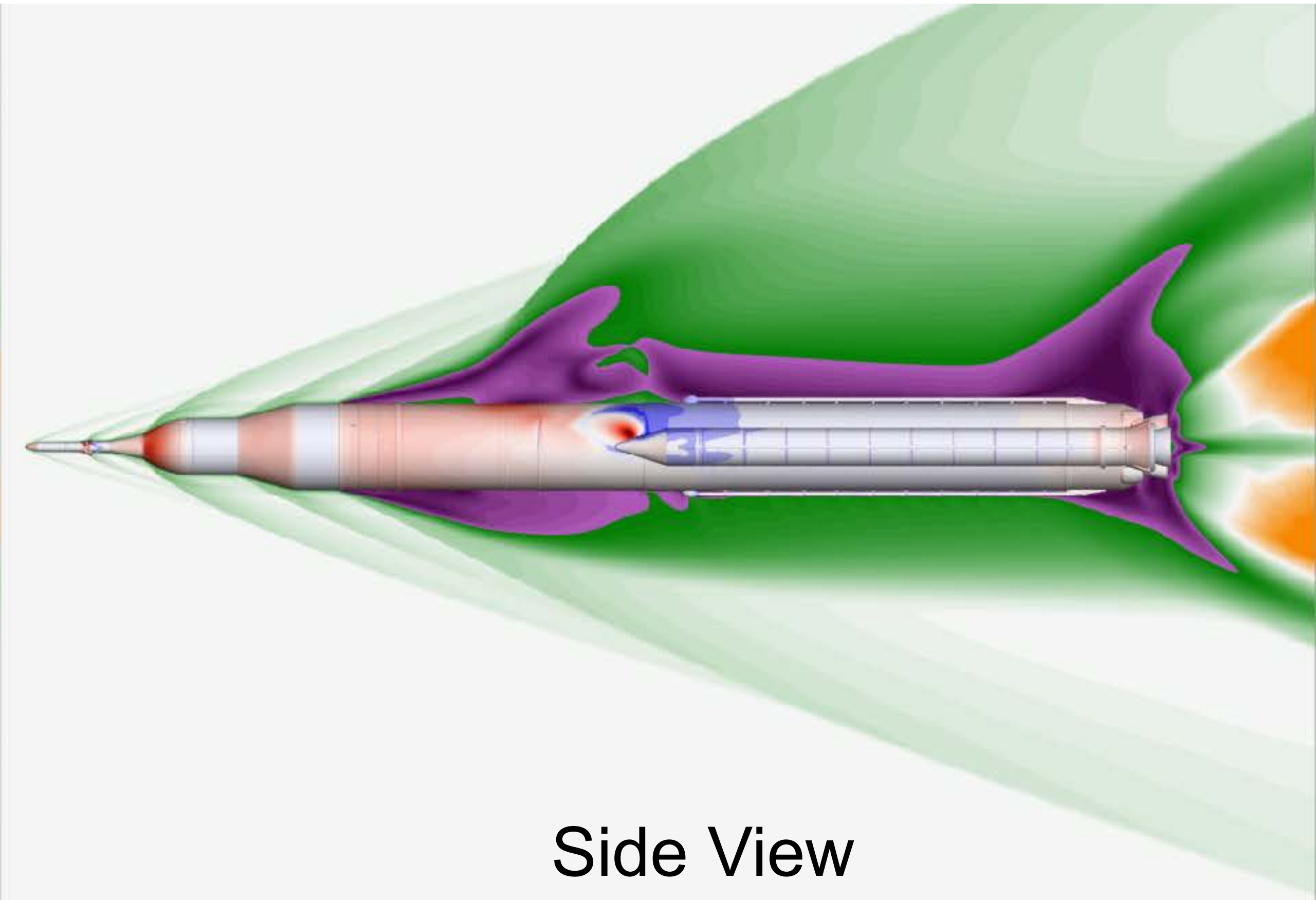
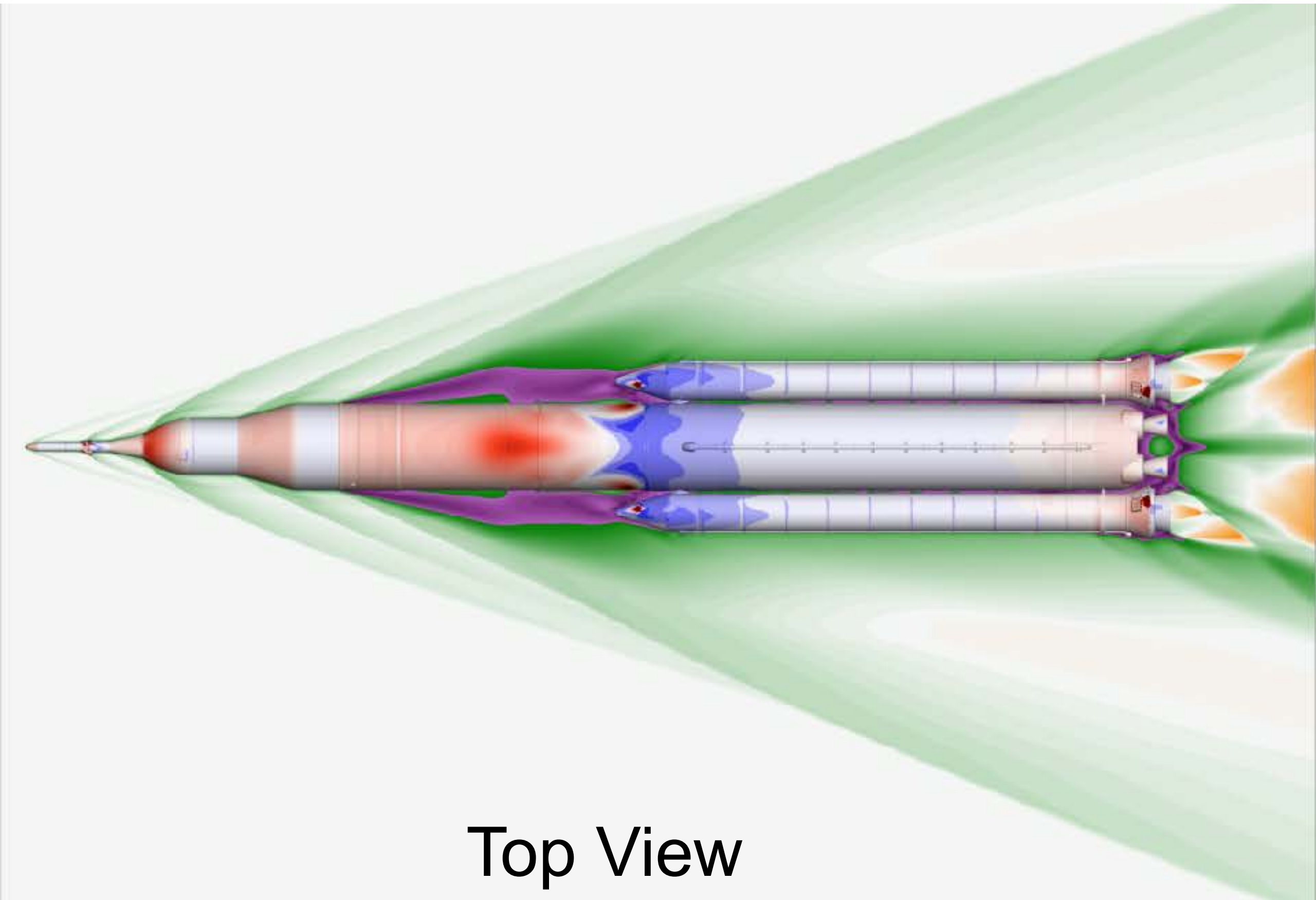

Background slice purple-green-white-orange color contours represent low to high velocities
Vehicle surface blue-white-red color contours represent low to high pressures

SLS Block 1B Crew Booster Separation

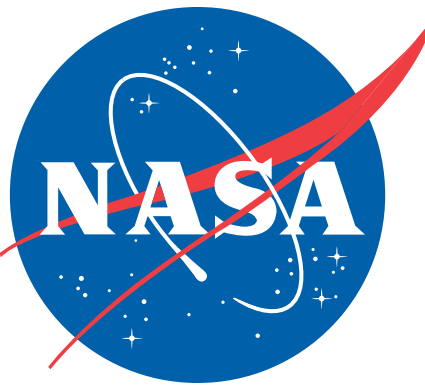

Booster Proximity: Attached • • • • • • • Separated

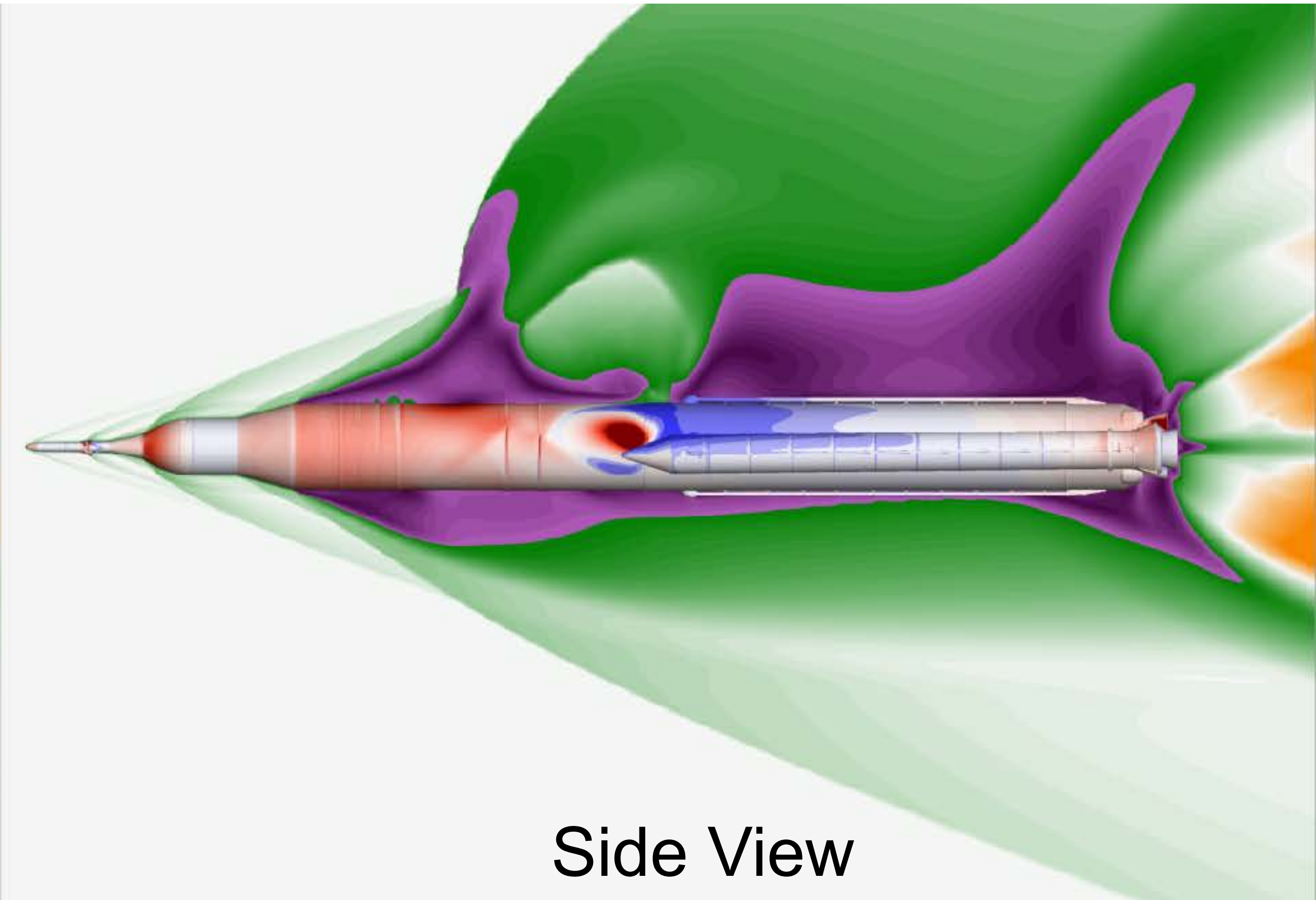
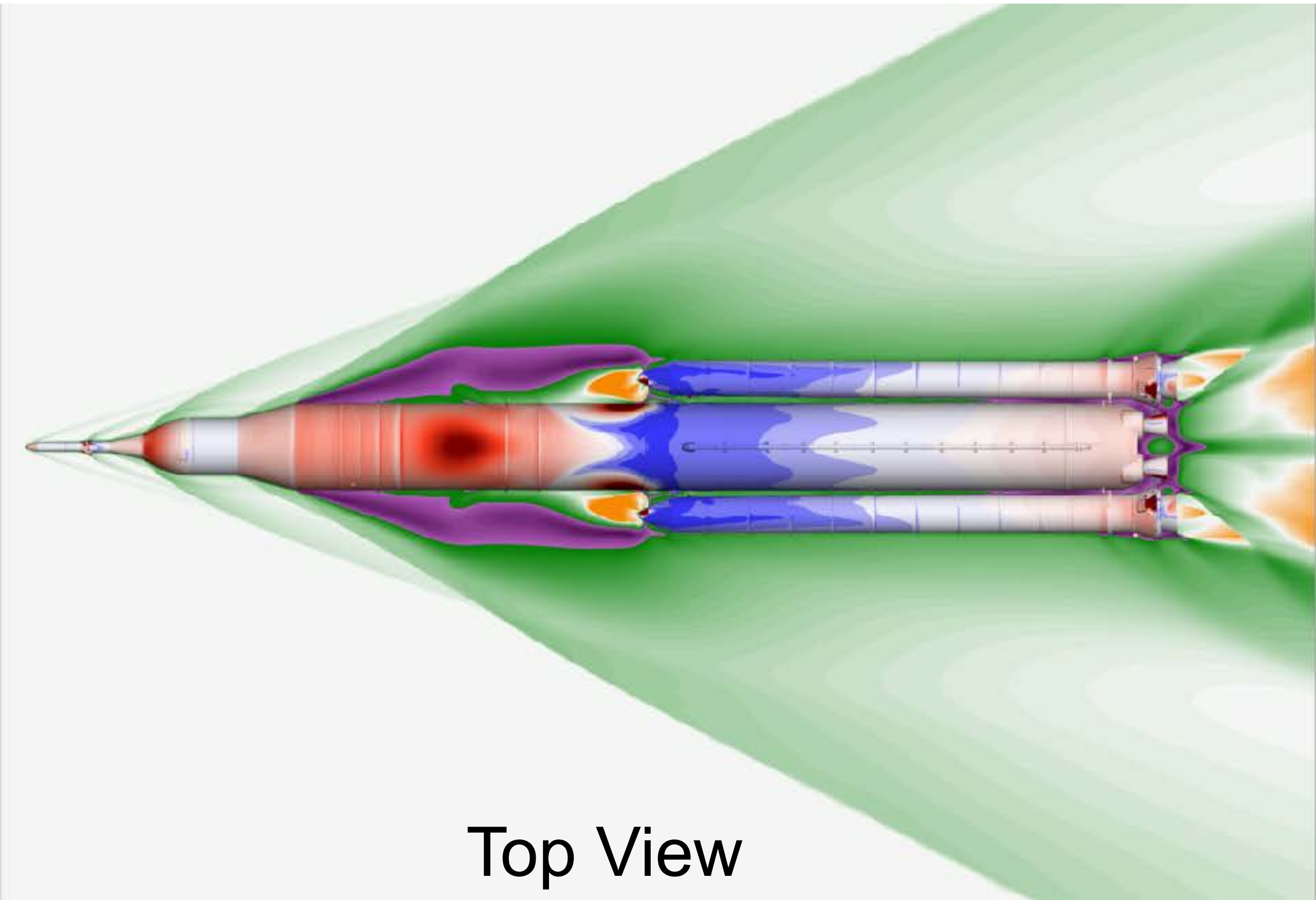

Background slice purple-green-white-orange color contours represent low to high velocities
Vehicle surface blue-white-red color contours represent low to high pressures

SLS Block 1B Crew Booster Separation

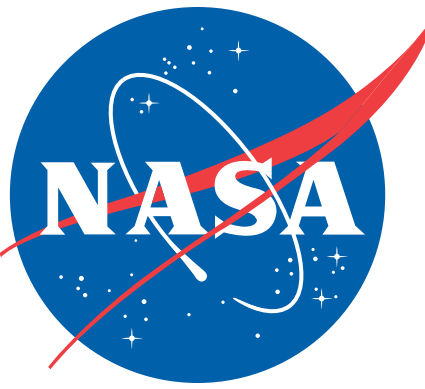

Booster Proximity: Attached • • • • • • • Separated

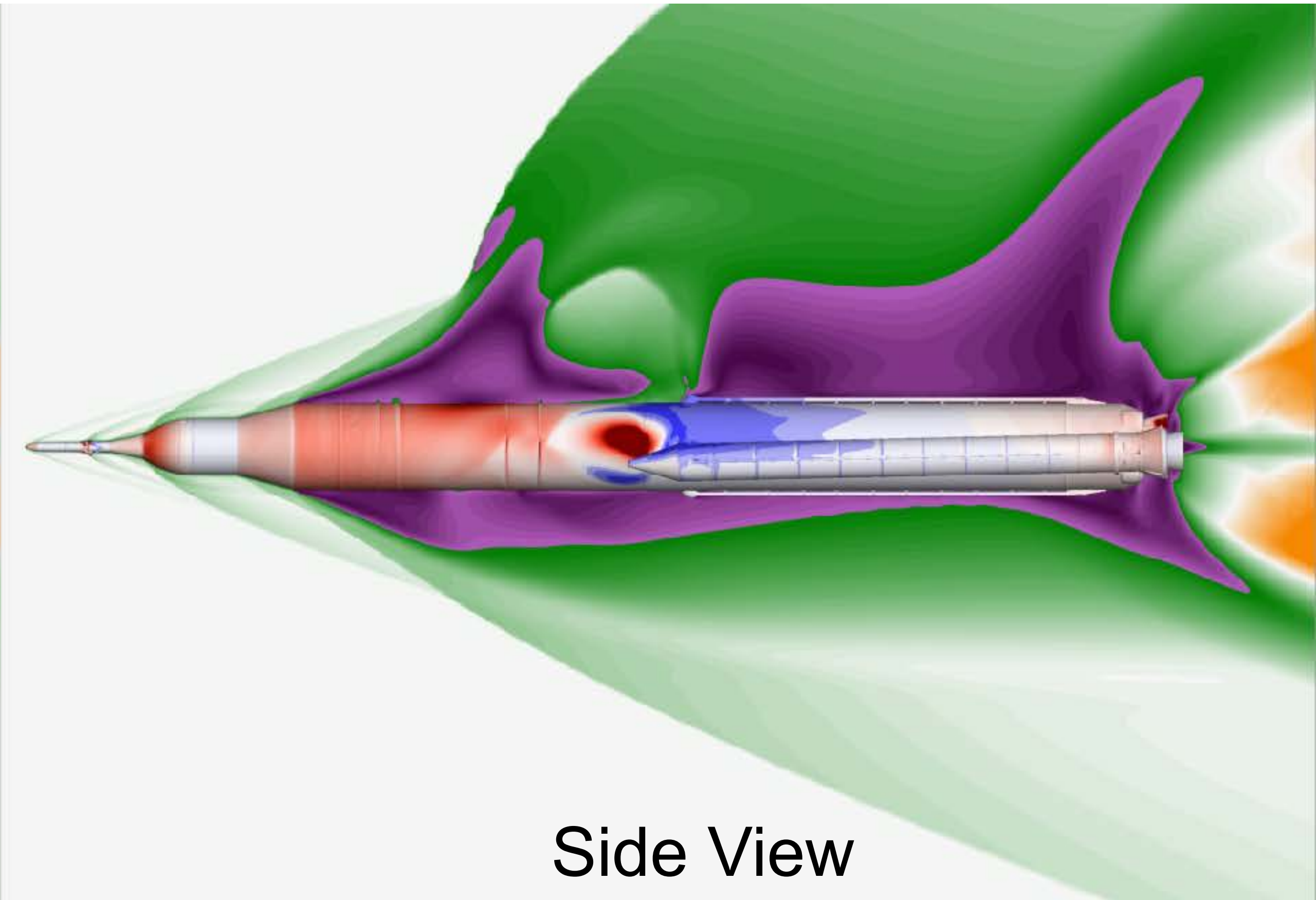
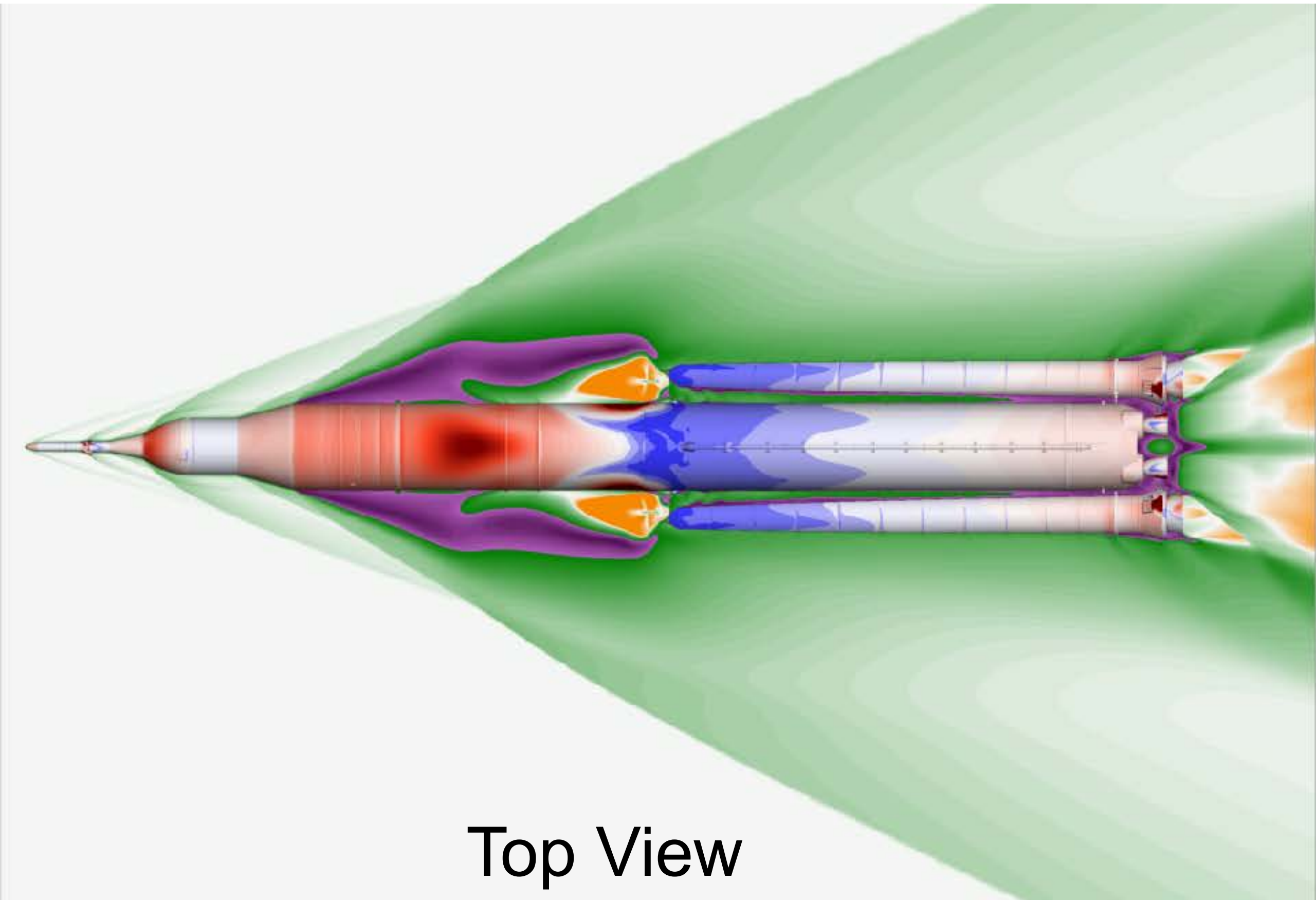

Background slice purple-green-white-orange color contours represent low to high velocities
Vehicle surface blue-white-red color contours represent low to high pressures

SLS Block 1B Crew Booster Separation

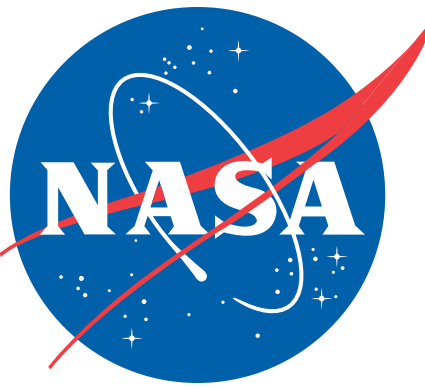

Booster Proximity: Attached Separated

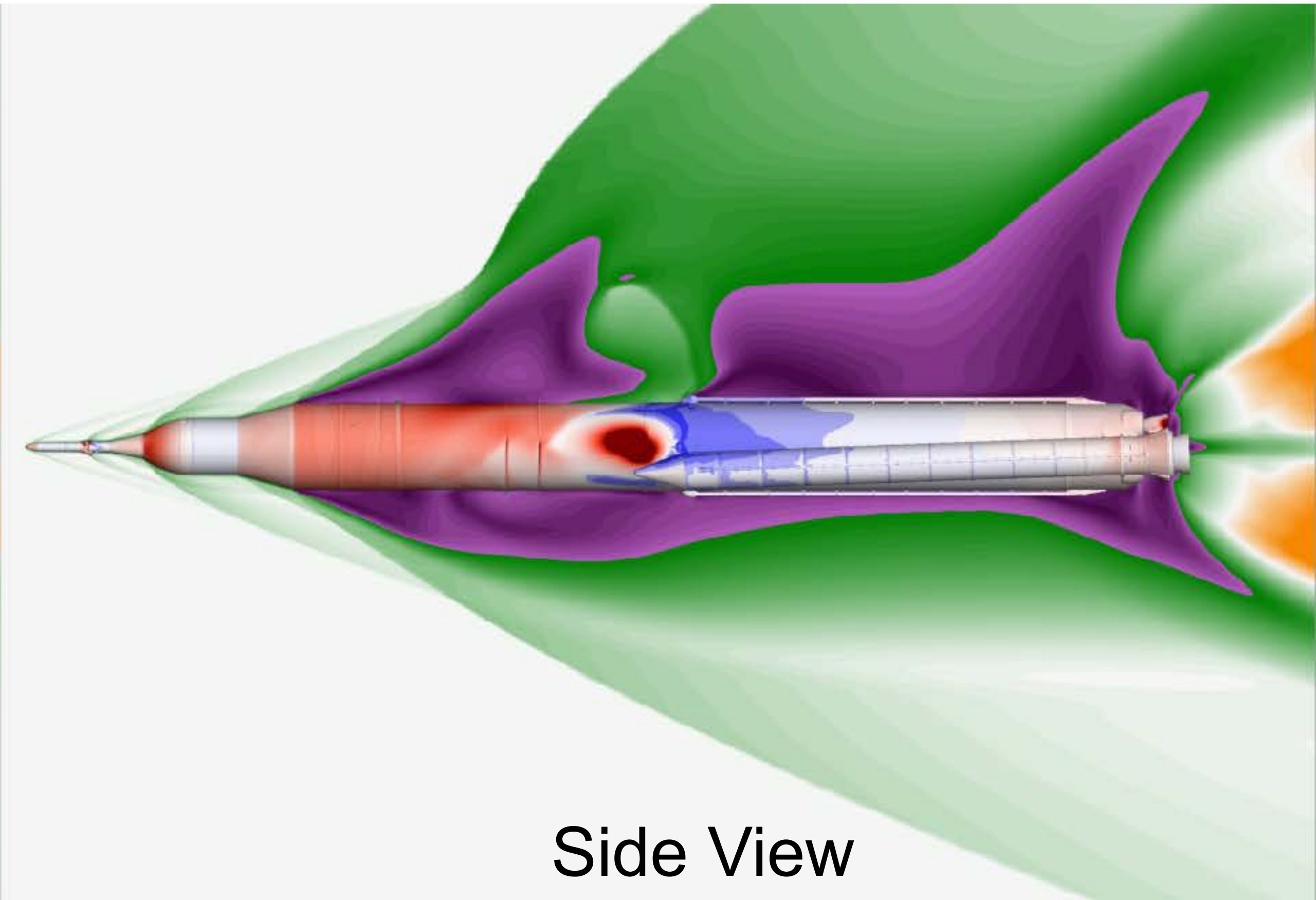
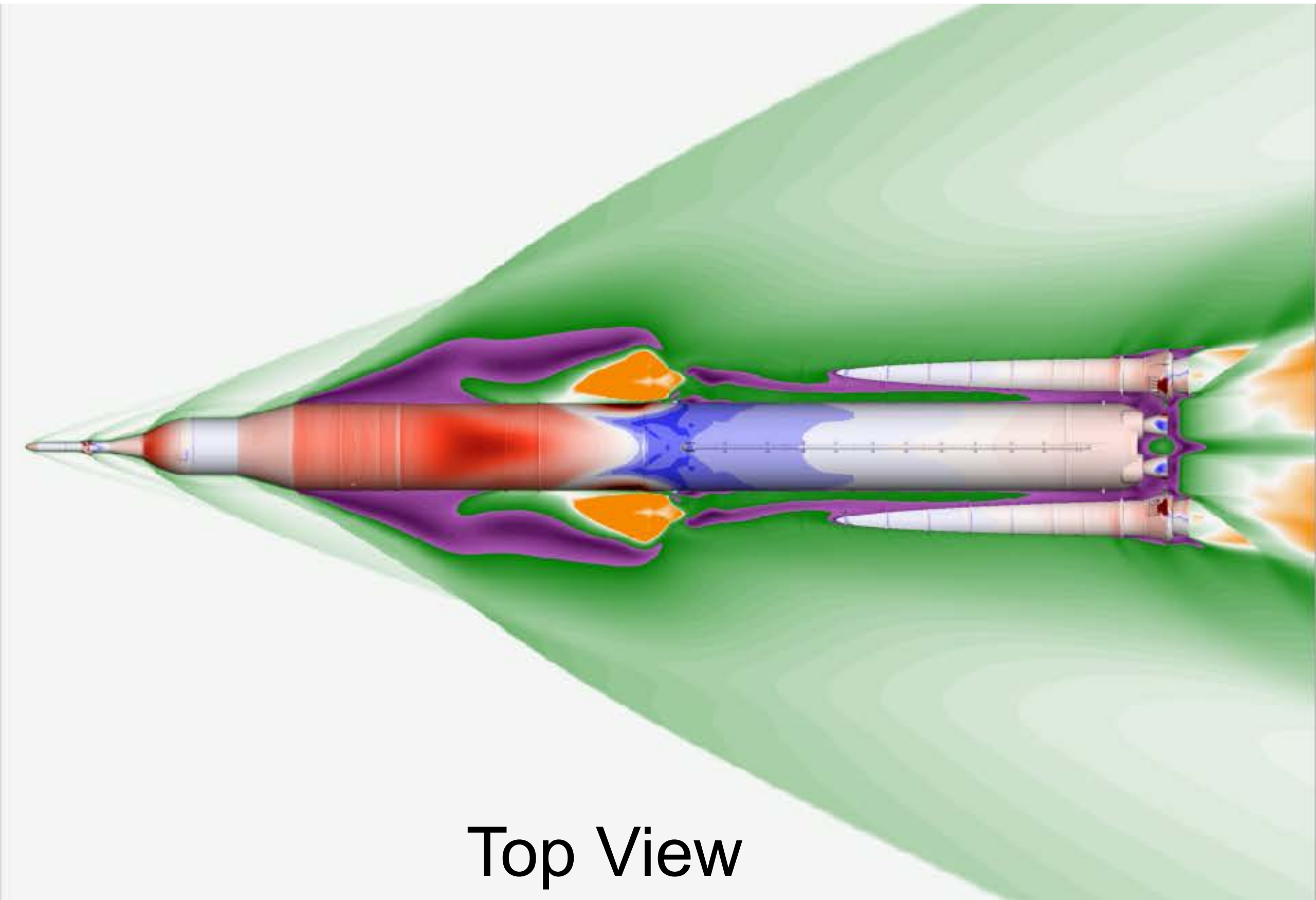

Background slice purple-green-white-orange color contours represent low to high velocities
Vehicle surface blue-white-red color contours represent low to high pressures

SLS Block 1B Crew Booster Separation

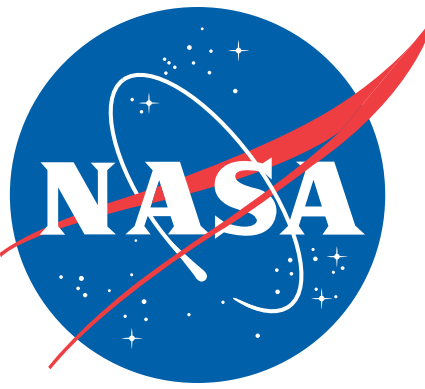

Booster Proximity: Attached Separated

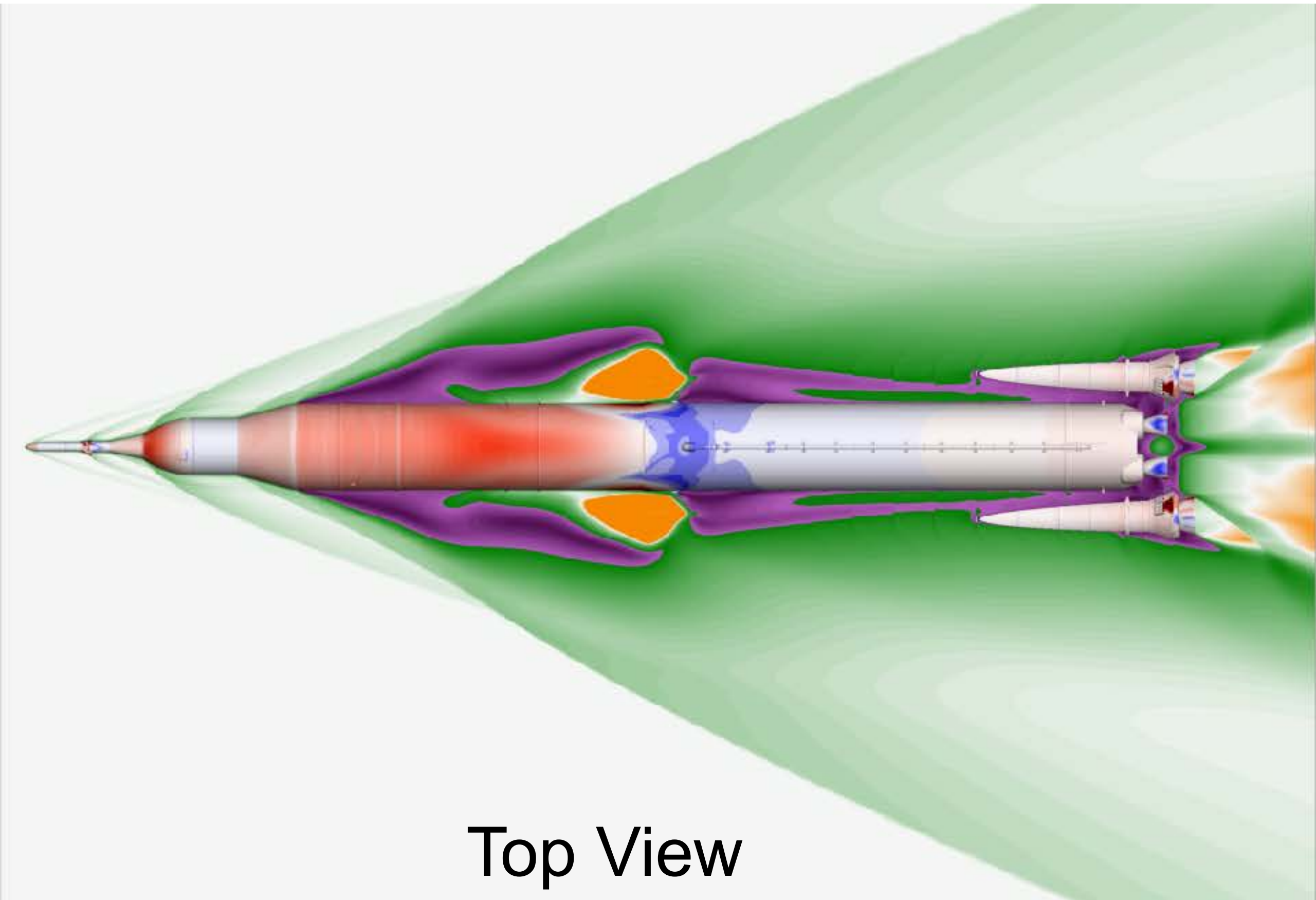

Top View

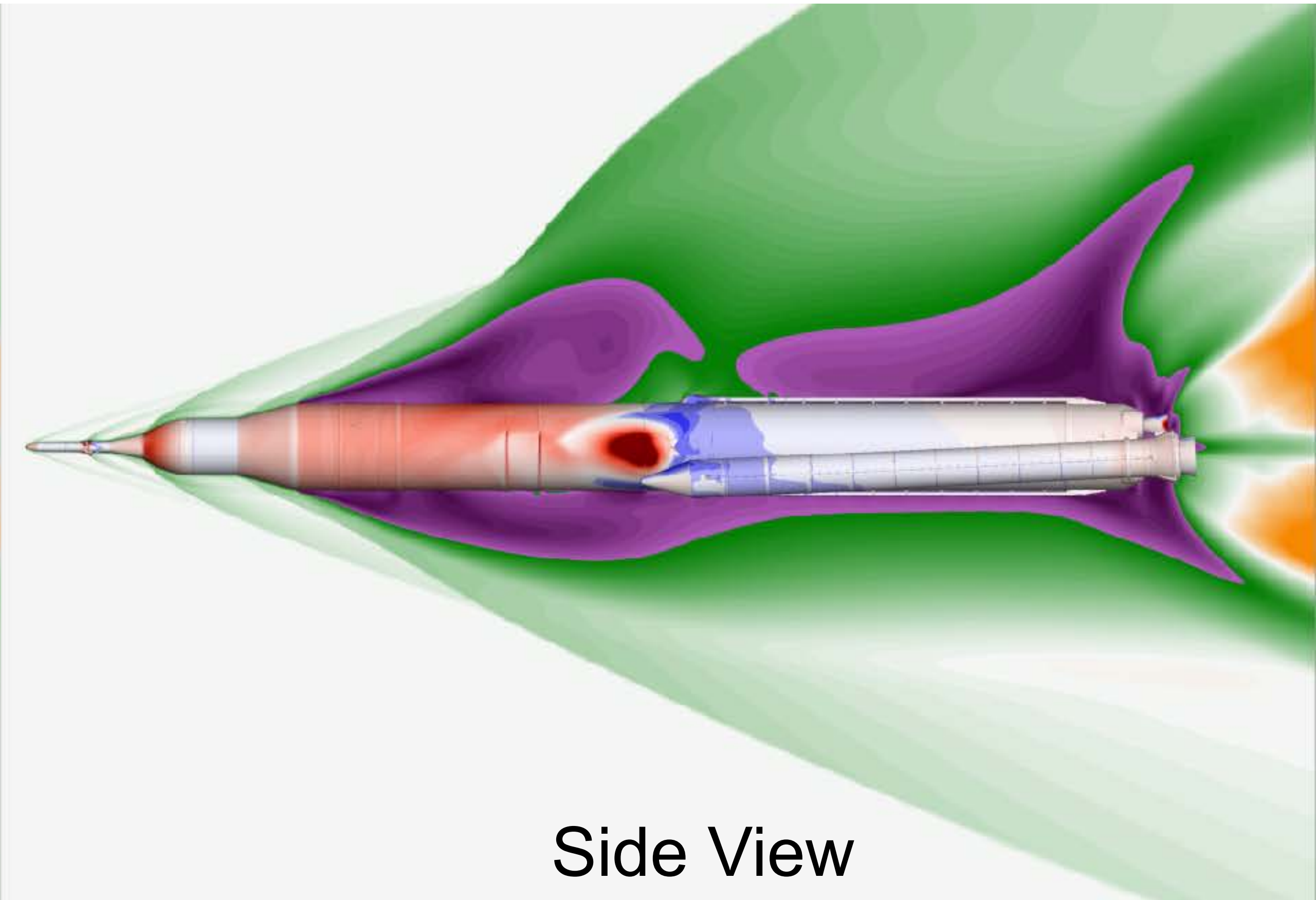

Side View

Background slice purple-green-white-orange color contours represent low to high velocities
Vehicle surface blue-white-red color contours represent low to high pressures

SLS Block 1B Crew Booster Separation

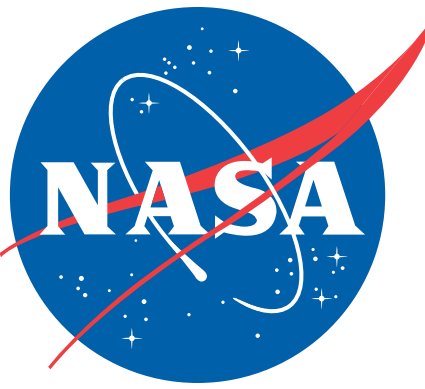

Booster Proximity: Attached Separated

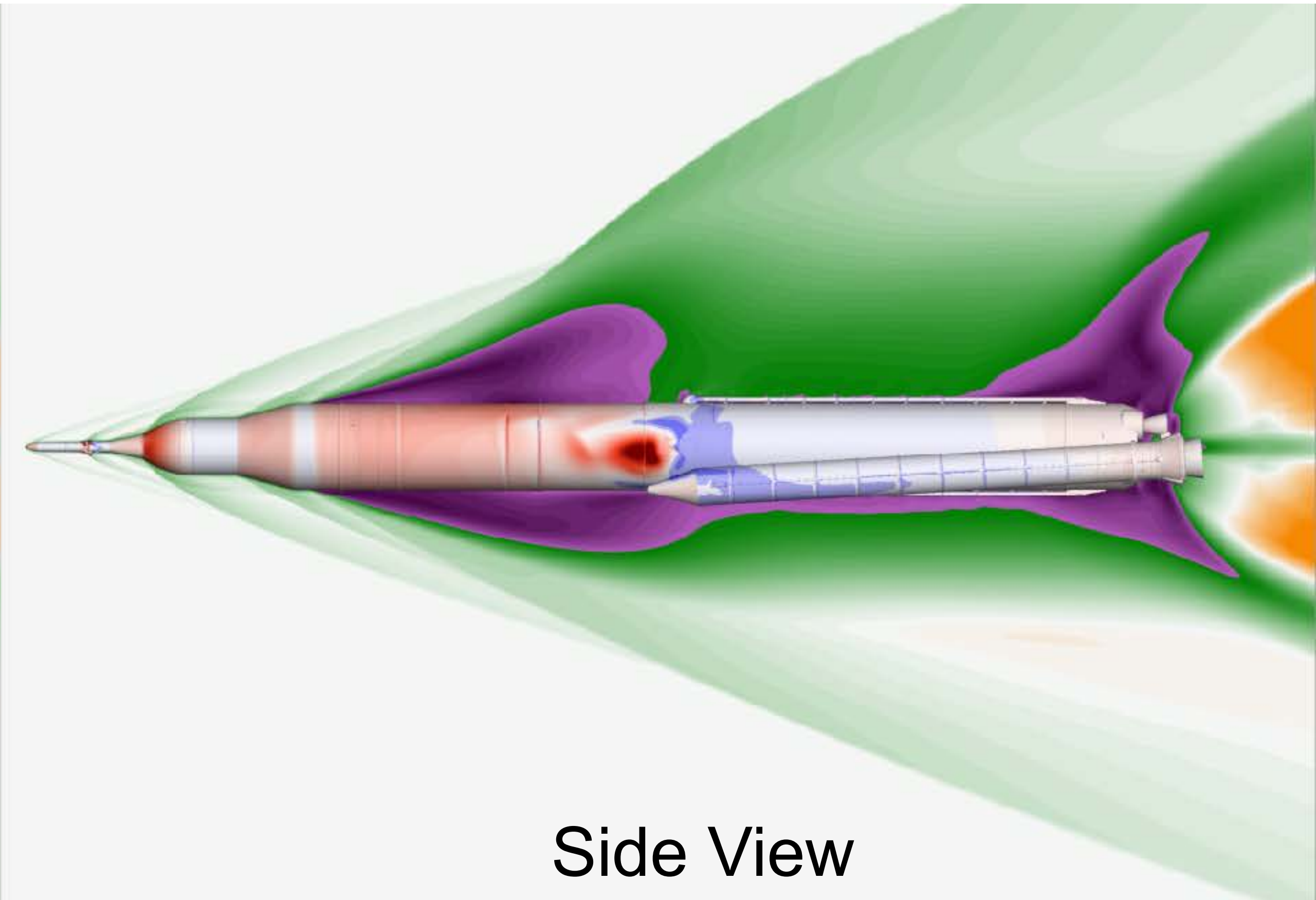
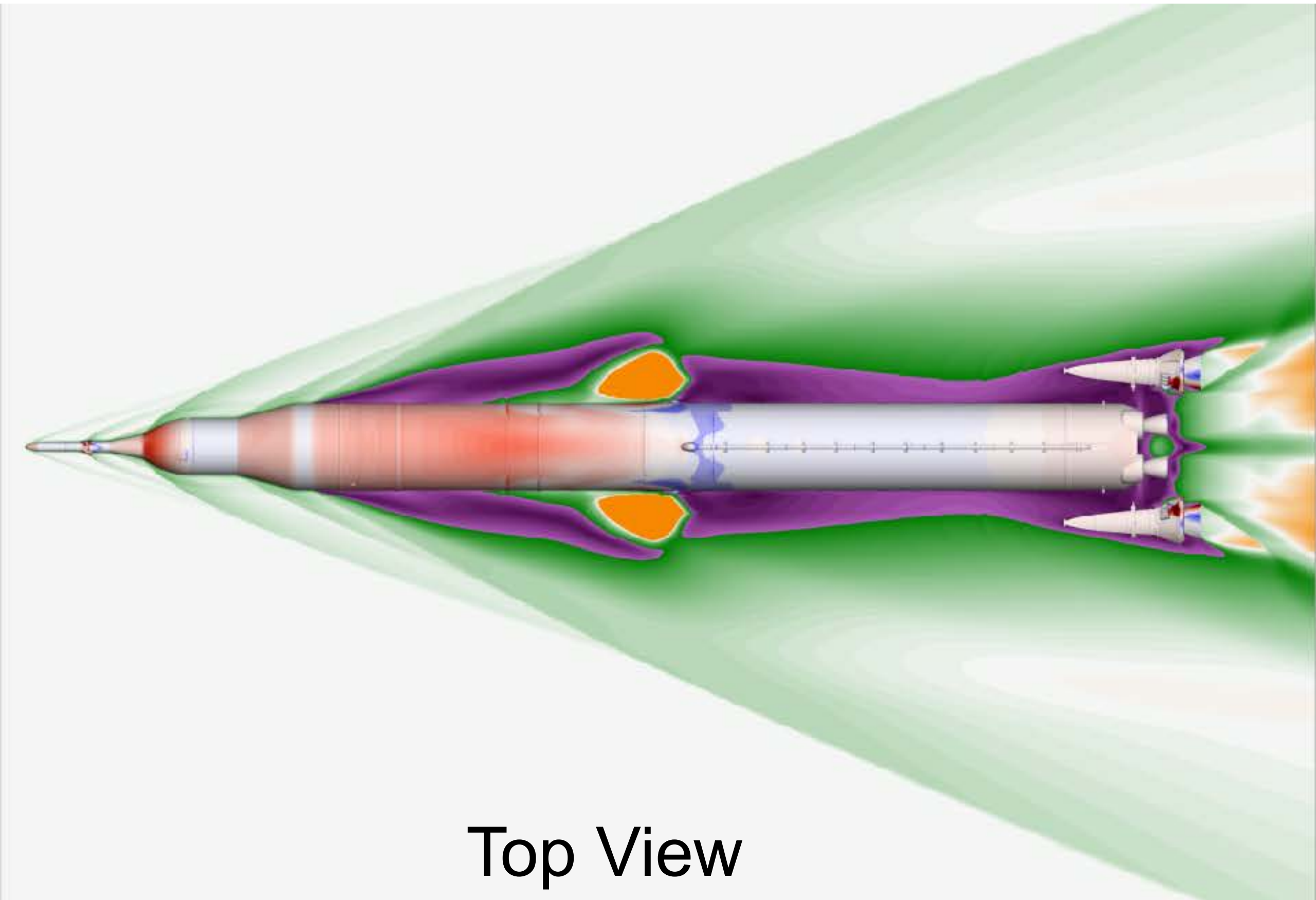

Background slice purple-green-white-orange color contours represent low to high velocities
Vehicle surface blue-white-red color contours represent low to high pressures

SLS Block 1B Crew Booster Separation

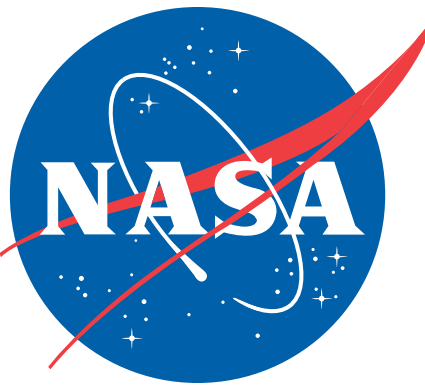

Booster Proximity: Attached • • • • • • • Separated

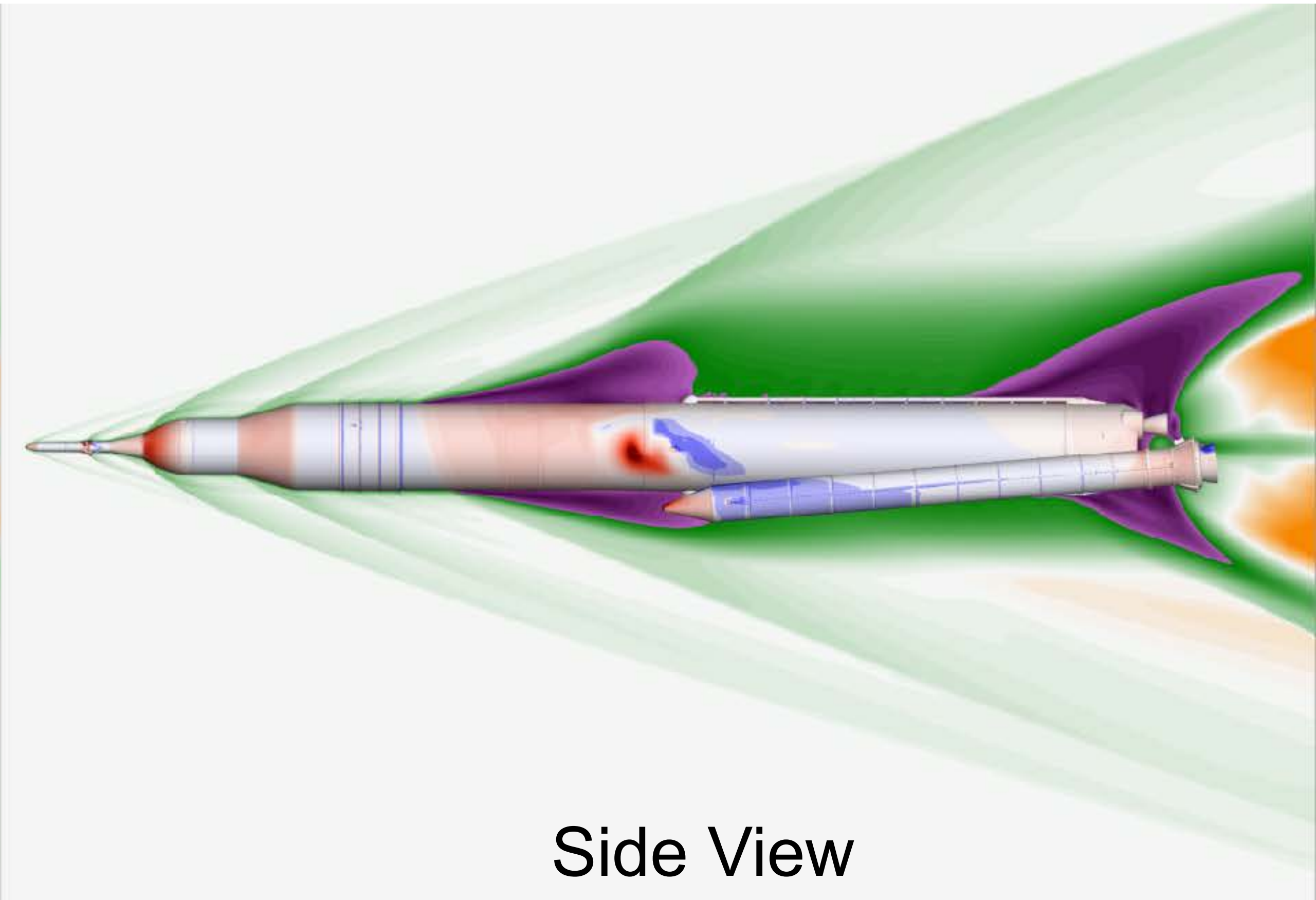
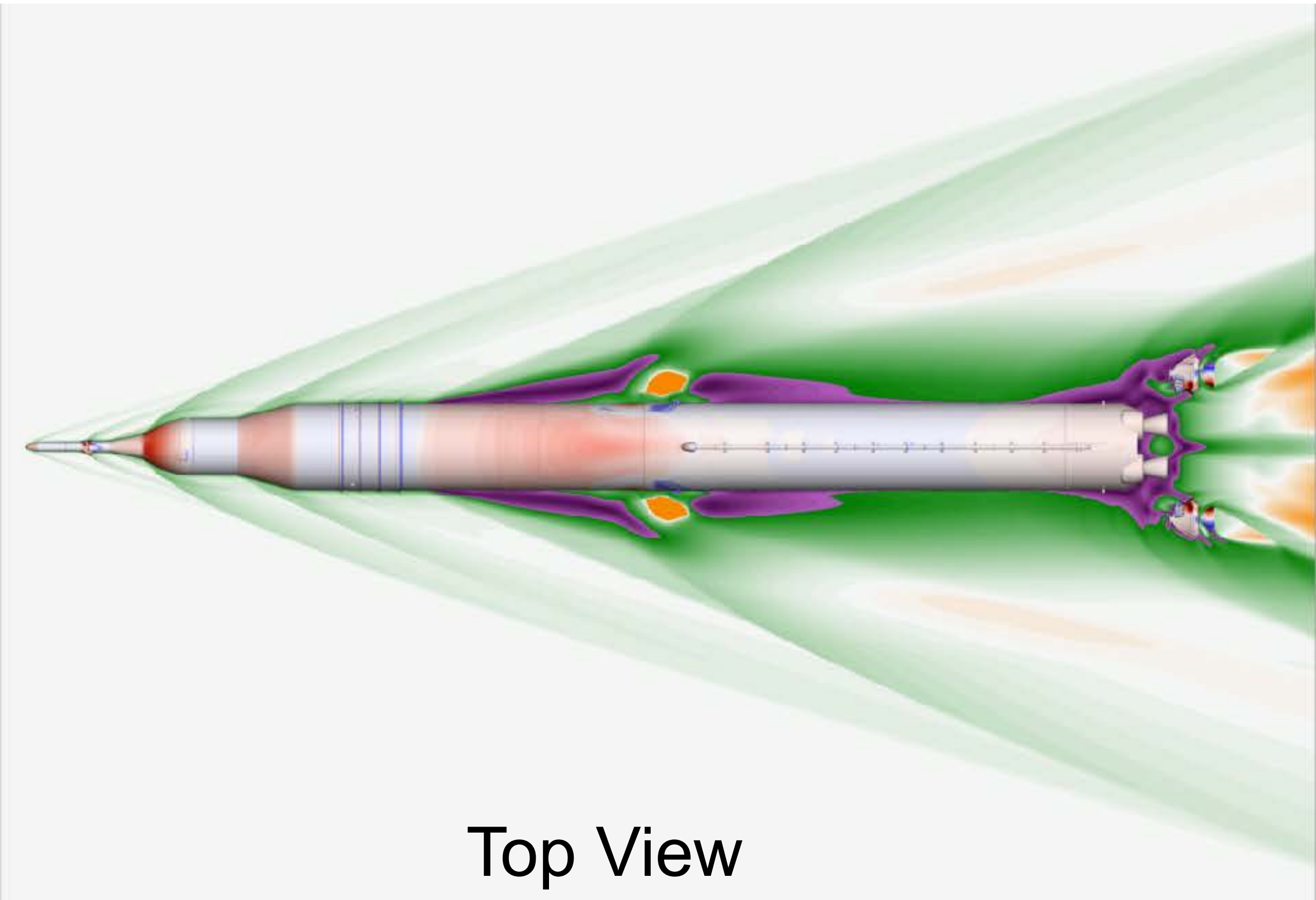

Background slice purple-green-white-orange color contours represent low to high velocities
Vehicle surface blue-white-red color contours represent low to high pressures

SLS Block 1B Crew Booster Separation

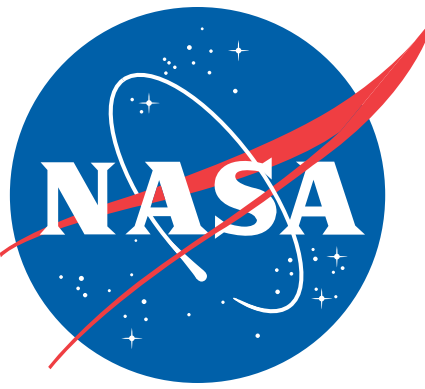

Booster Proximity: Attached • • • • • • • Separated

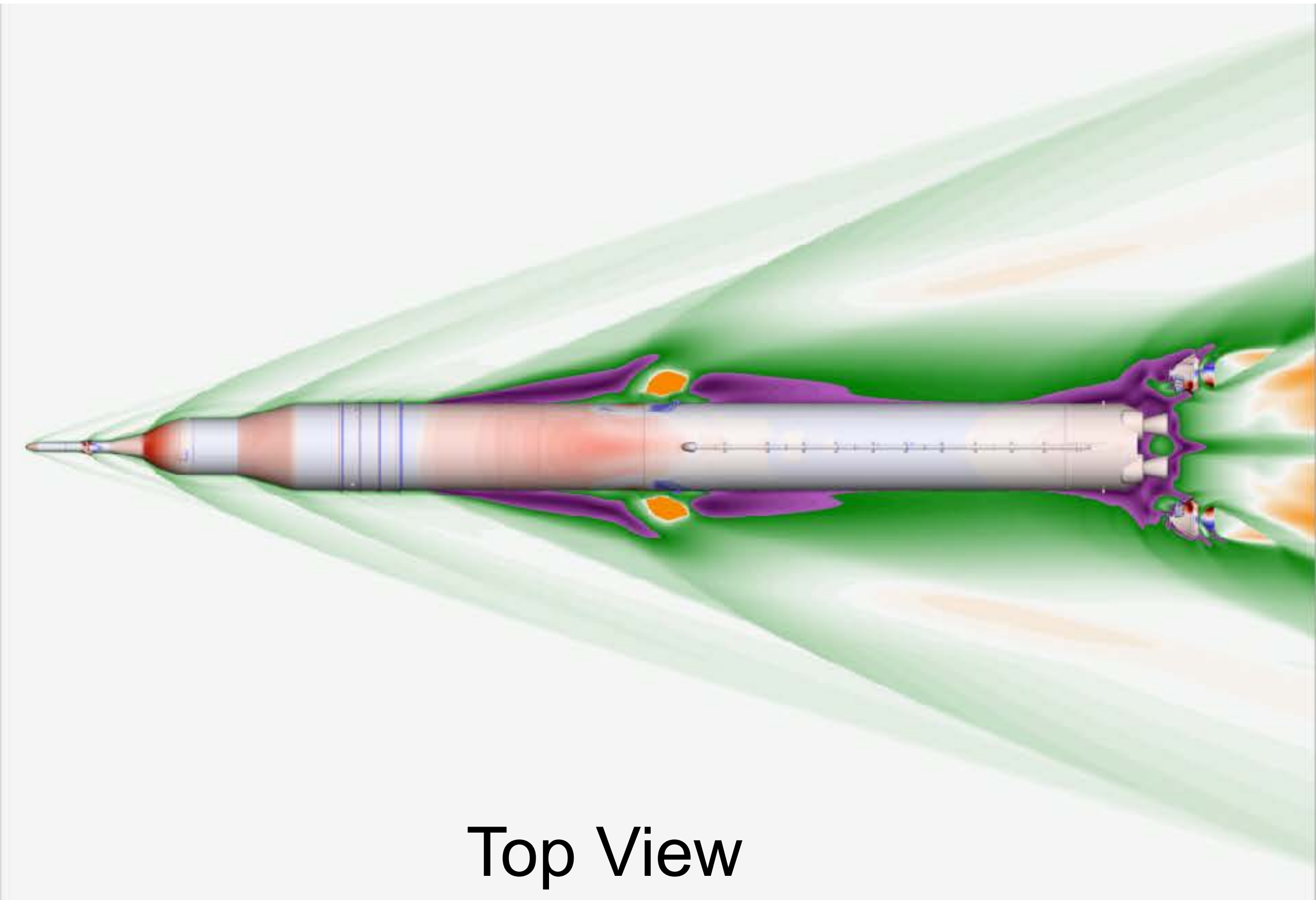

Top View

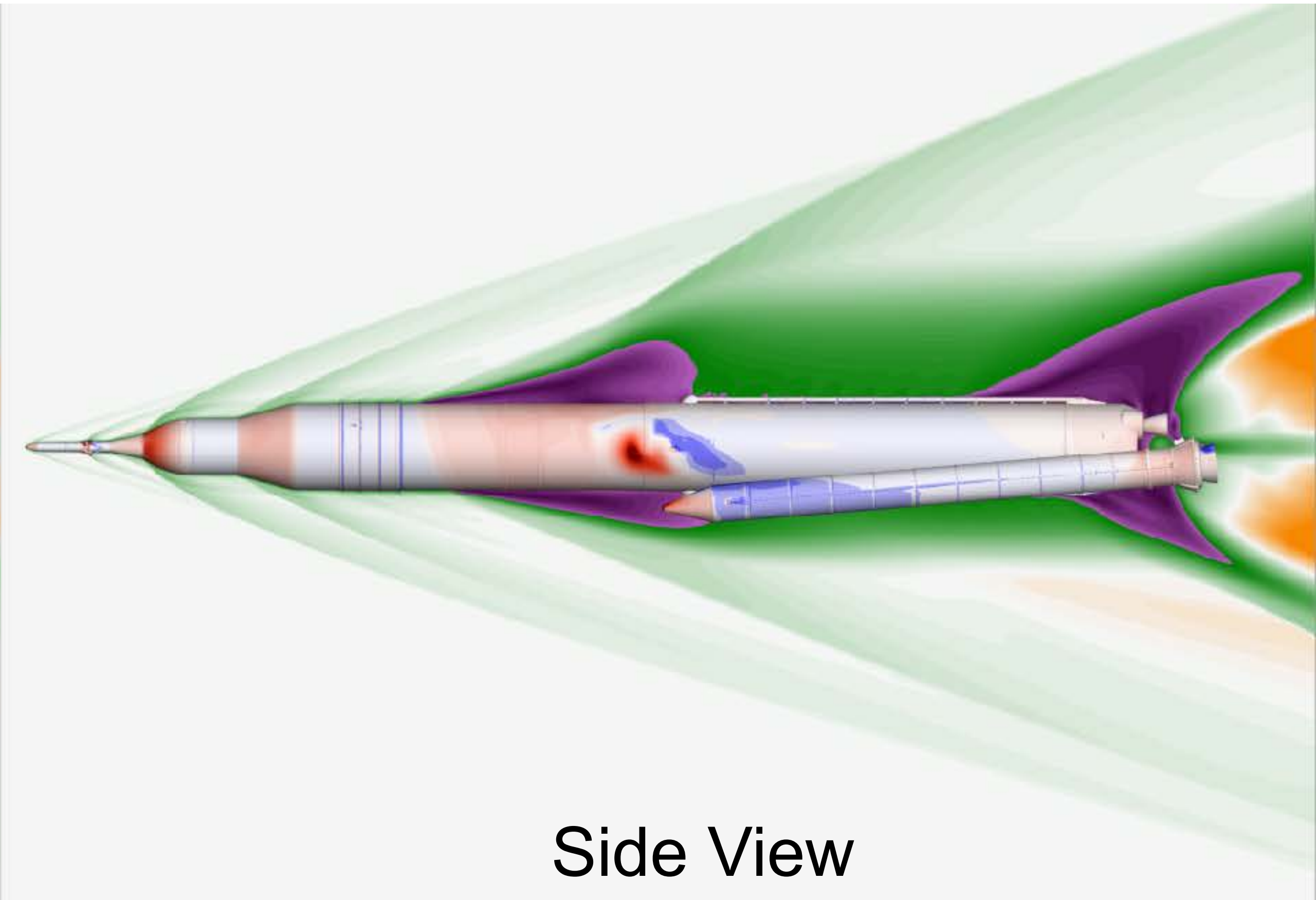

Side View

Background slice purple-green-white-orange color contours represent low to high velocities
Vehicle surface blue-white-red color contours represent low to high pressures

SLS Block 1B Cargo Ascent

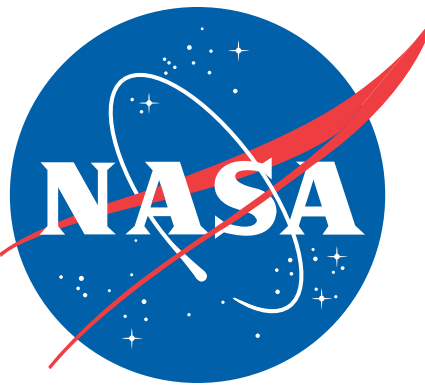

Altitude: Low • • • • • • • • • • • • • • • • High

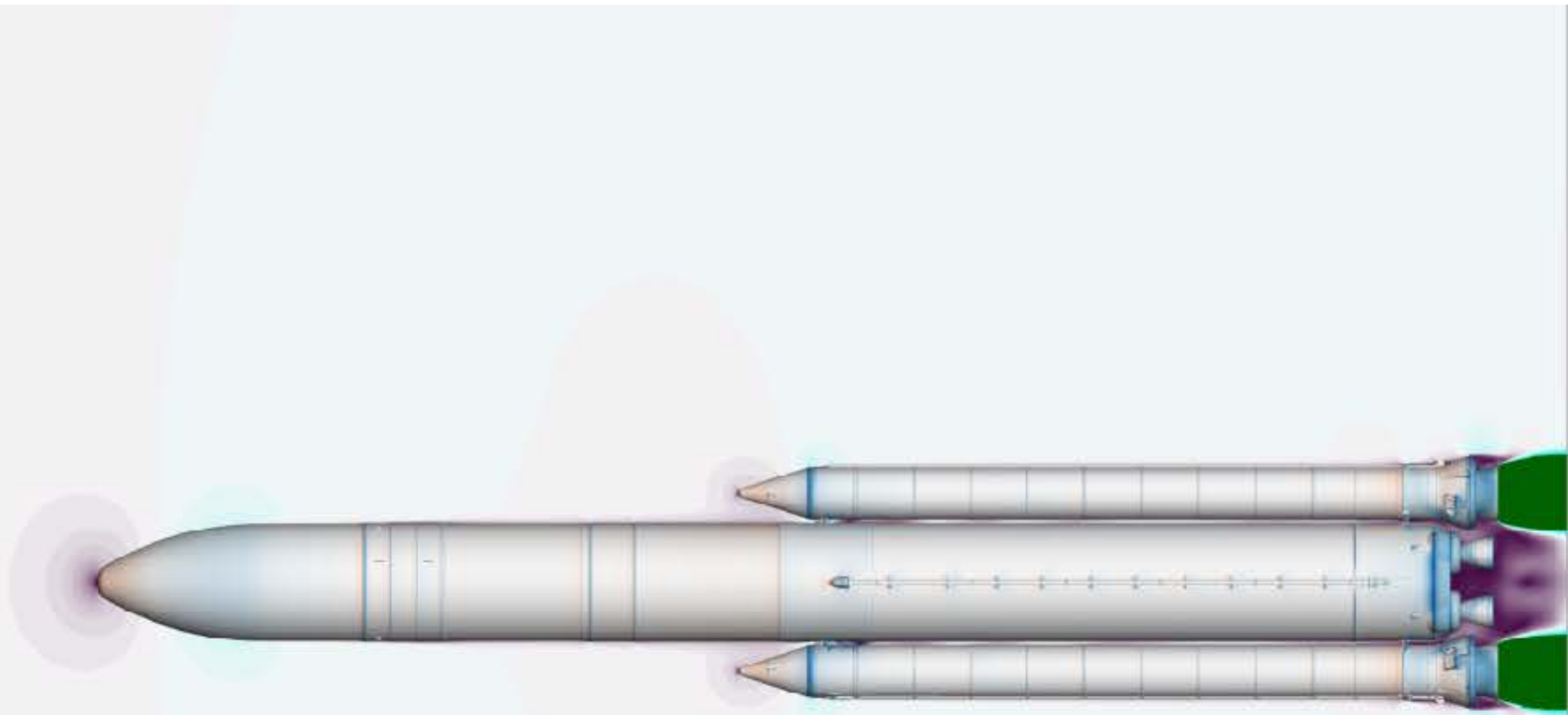

Top View

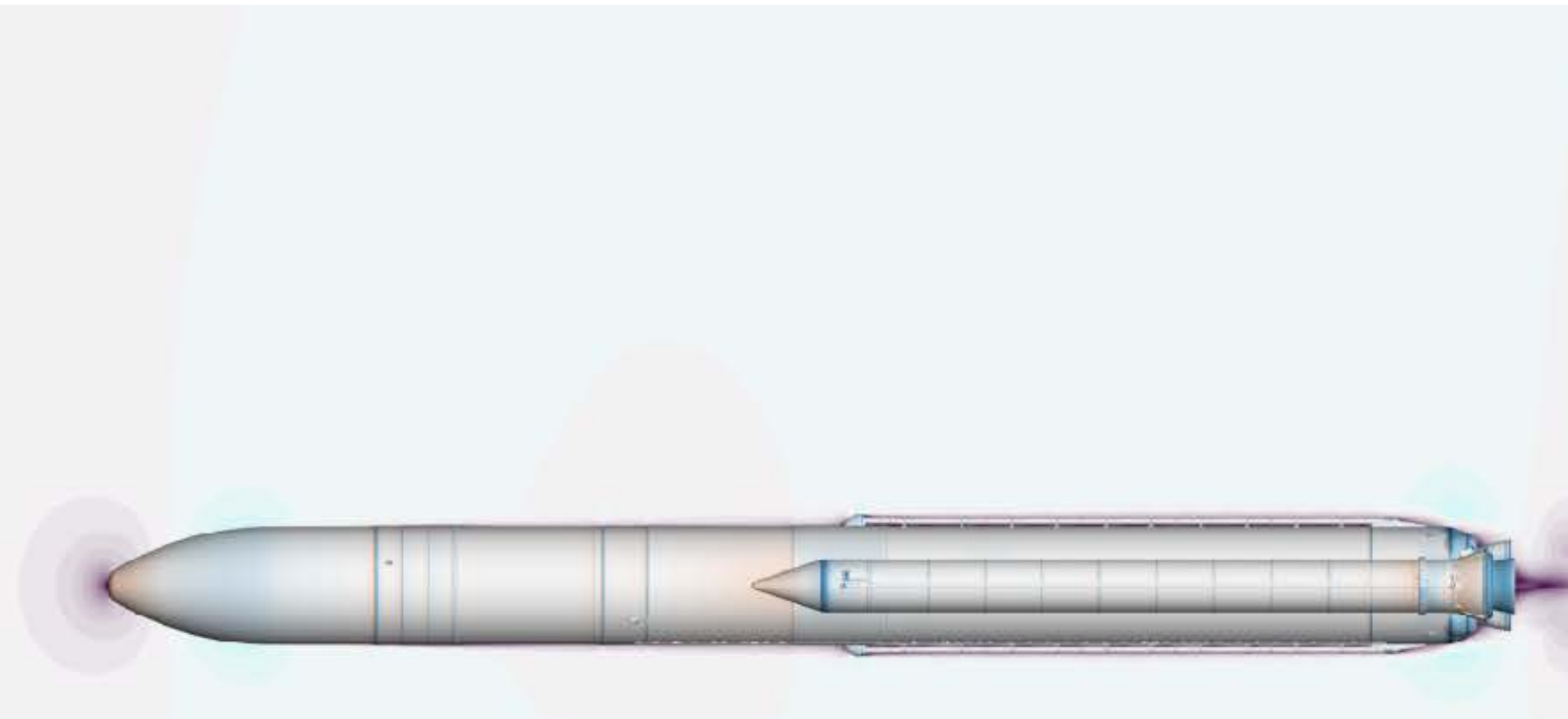

Side View

Background slice purple-green-white-orange color contours represent low to high velocities
Vehicle surface blue-white-red color contours represent low to high pressures

SLS Block 1B Cargo Ascent

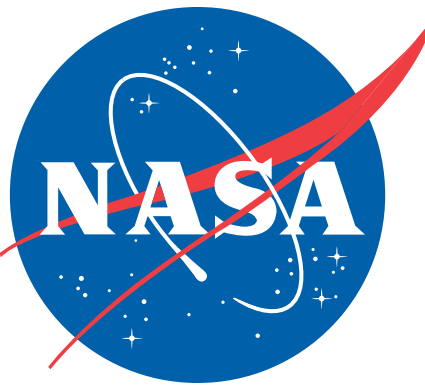

Altitude: Low • • • • • • • • • • • • • • • • High

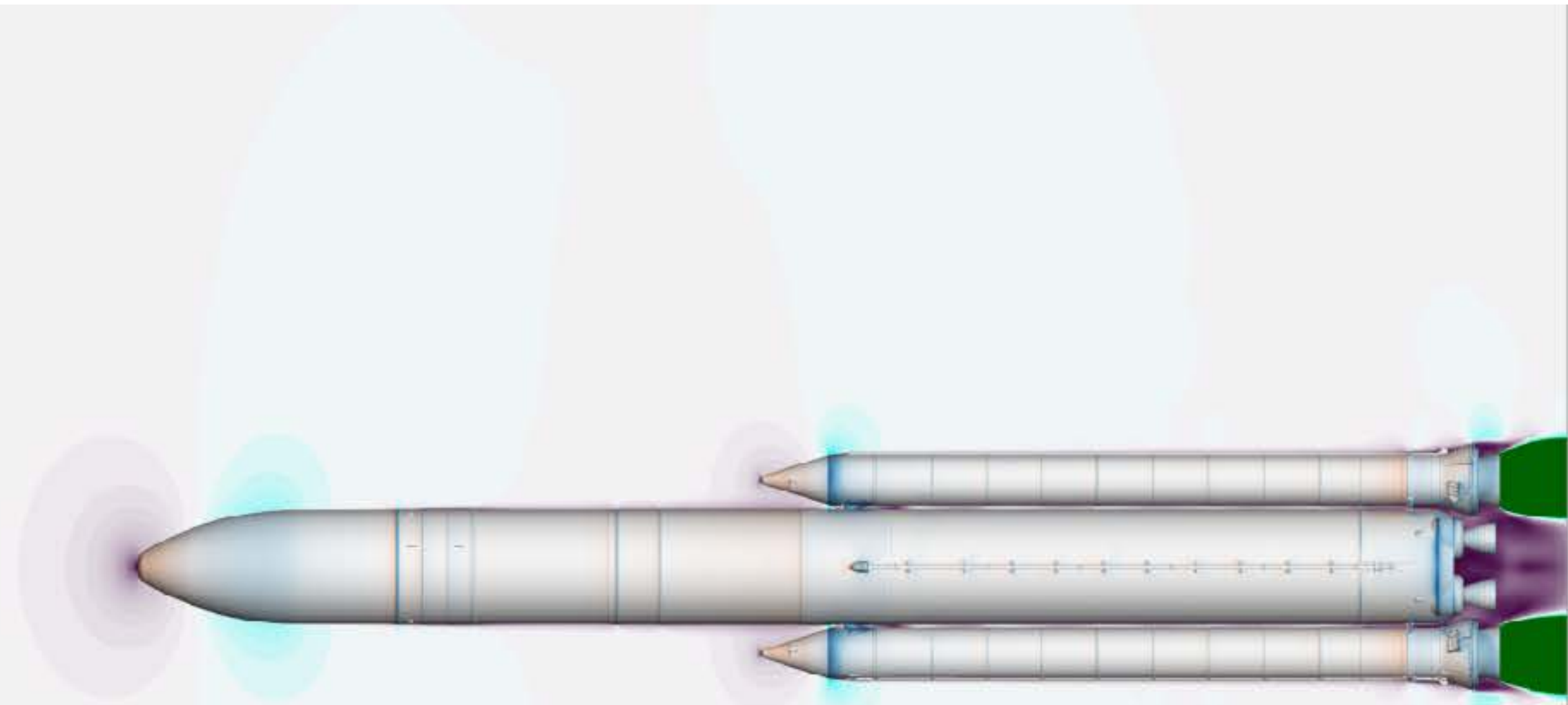

Top View

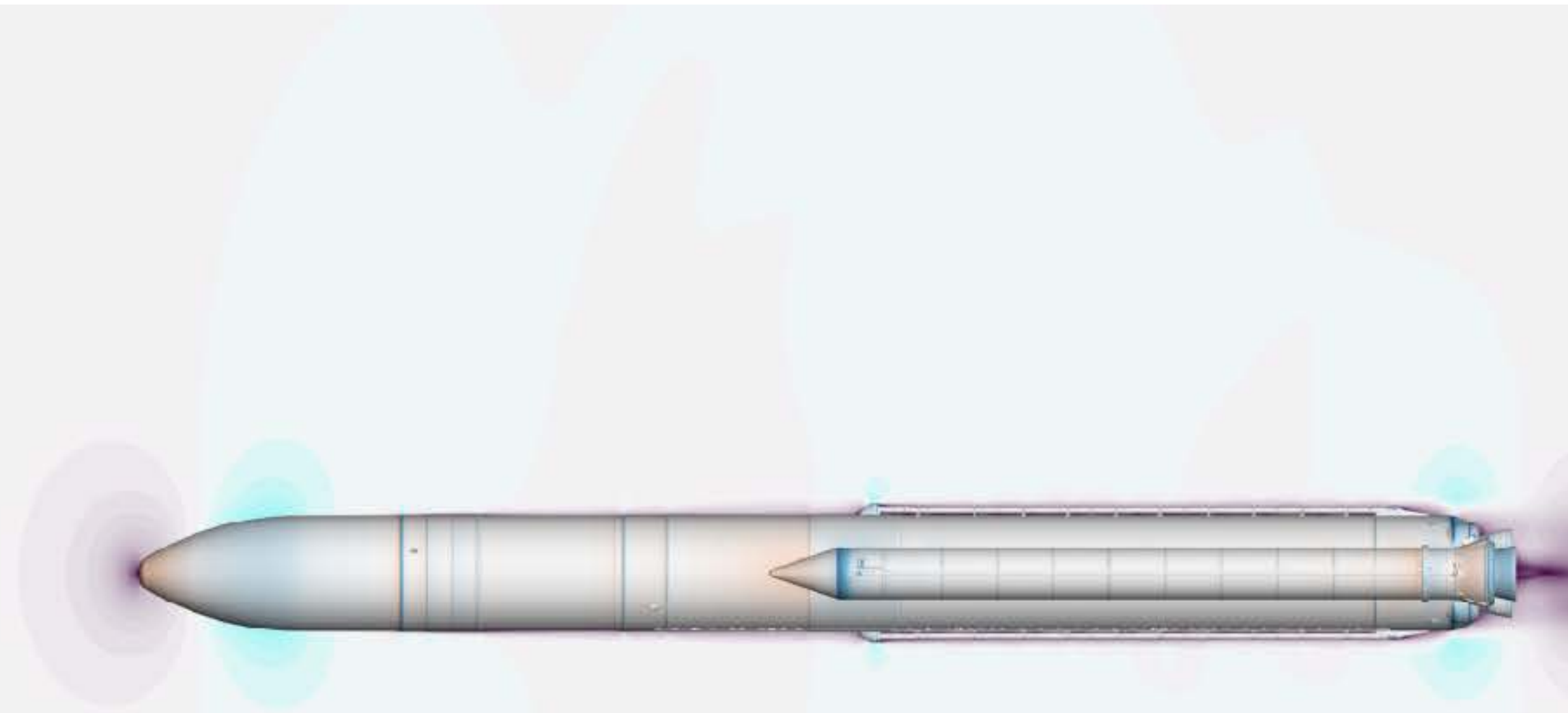

Side View

Background slice purple-green-white-orange color contours represent low to high velocities
Vehicle surface blue-white-red color contours represent low to high pressures

SLS Block 1B Cargo Ascent

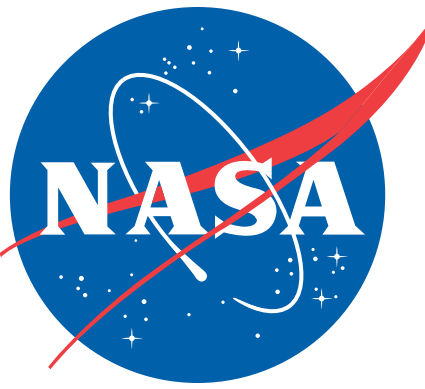

Altitude: Low • • • • • • • • • • • • • • • • High

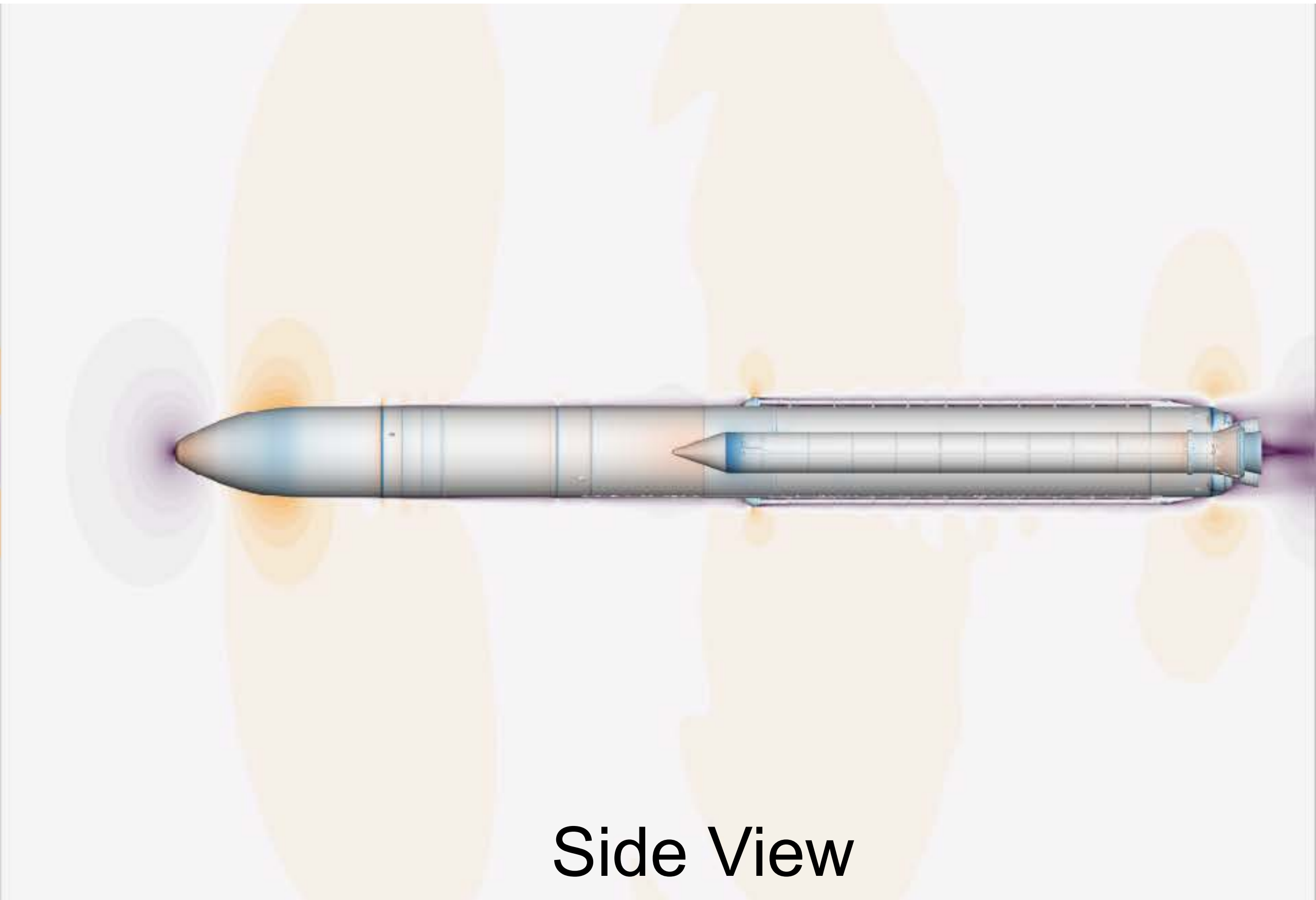
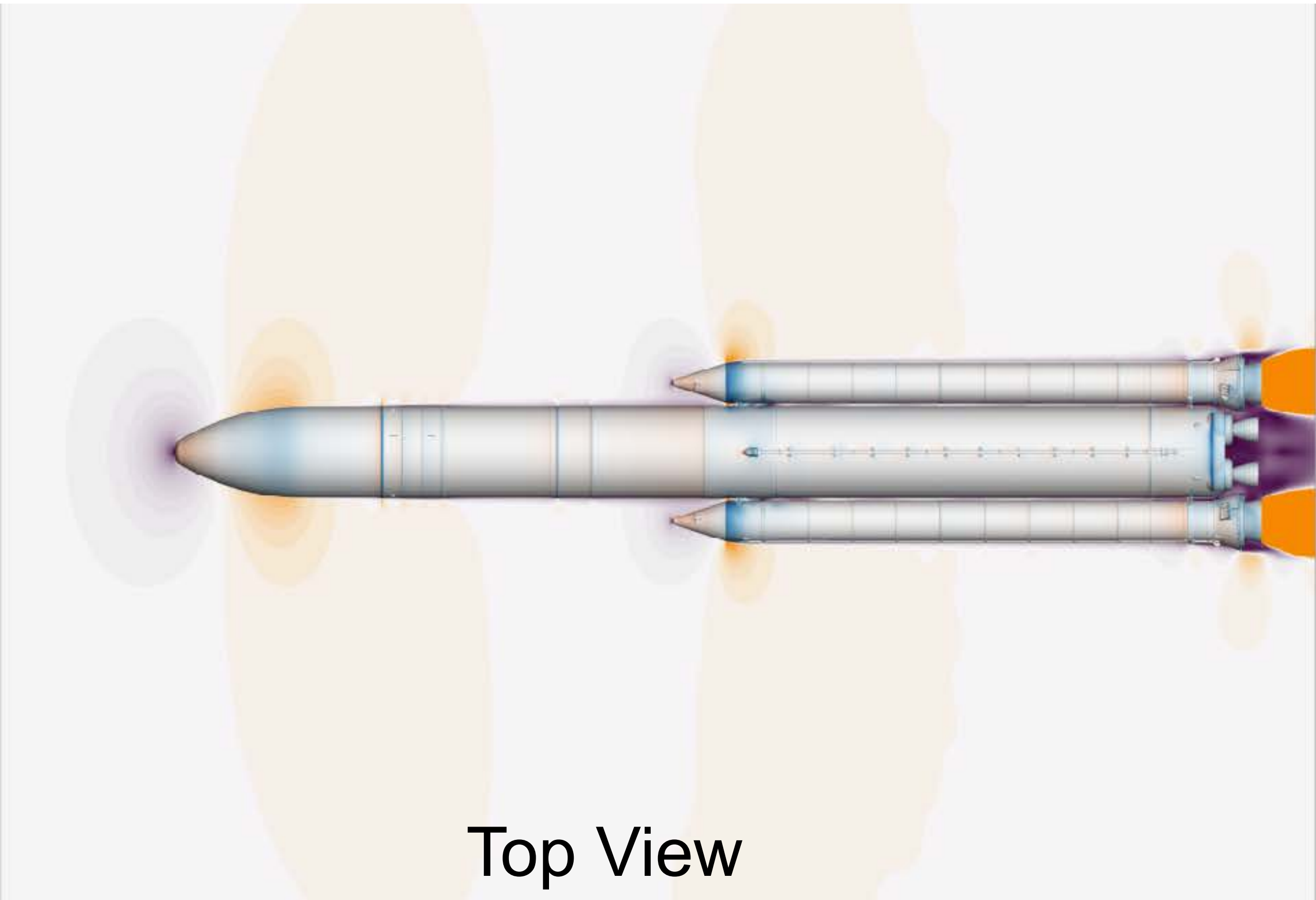

Background slice purple-green-white-orange color contours represent low to high velocities
Vehicle surface blue-white-red color contours represent low to high pressures

SLS Block 1B Cargo Ascent

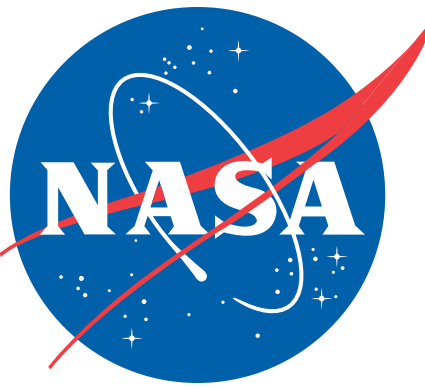

Altitude: Low • • • • • • • • • • • • • • High

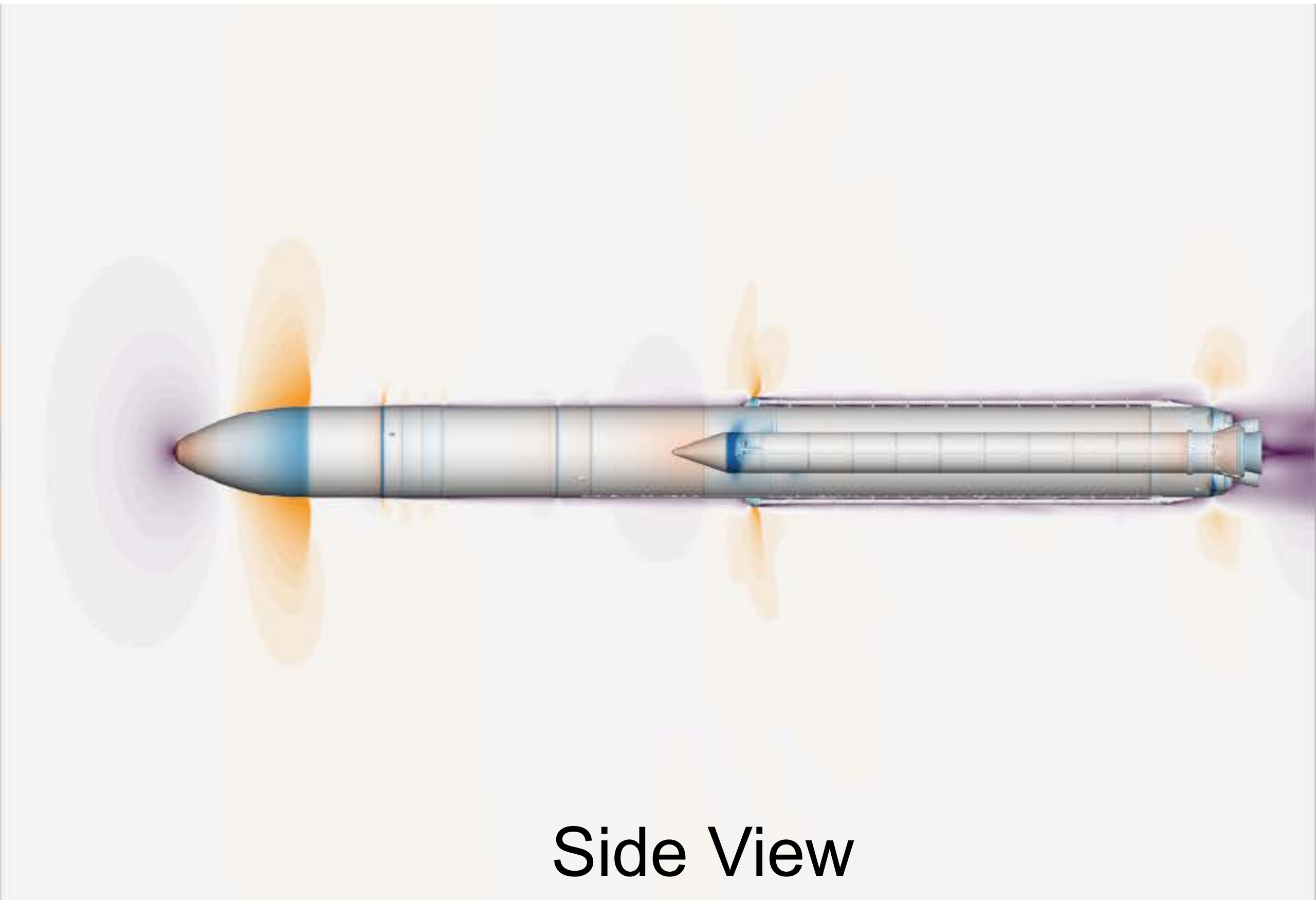
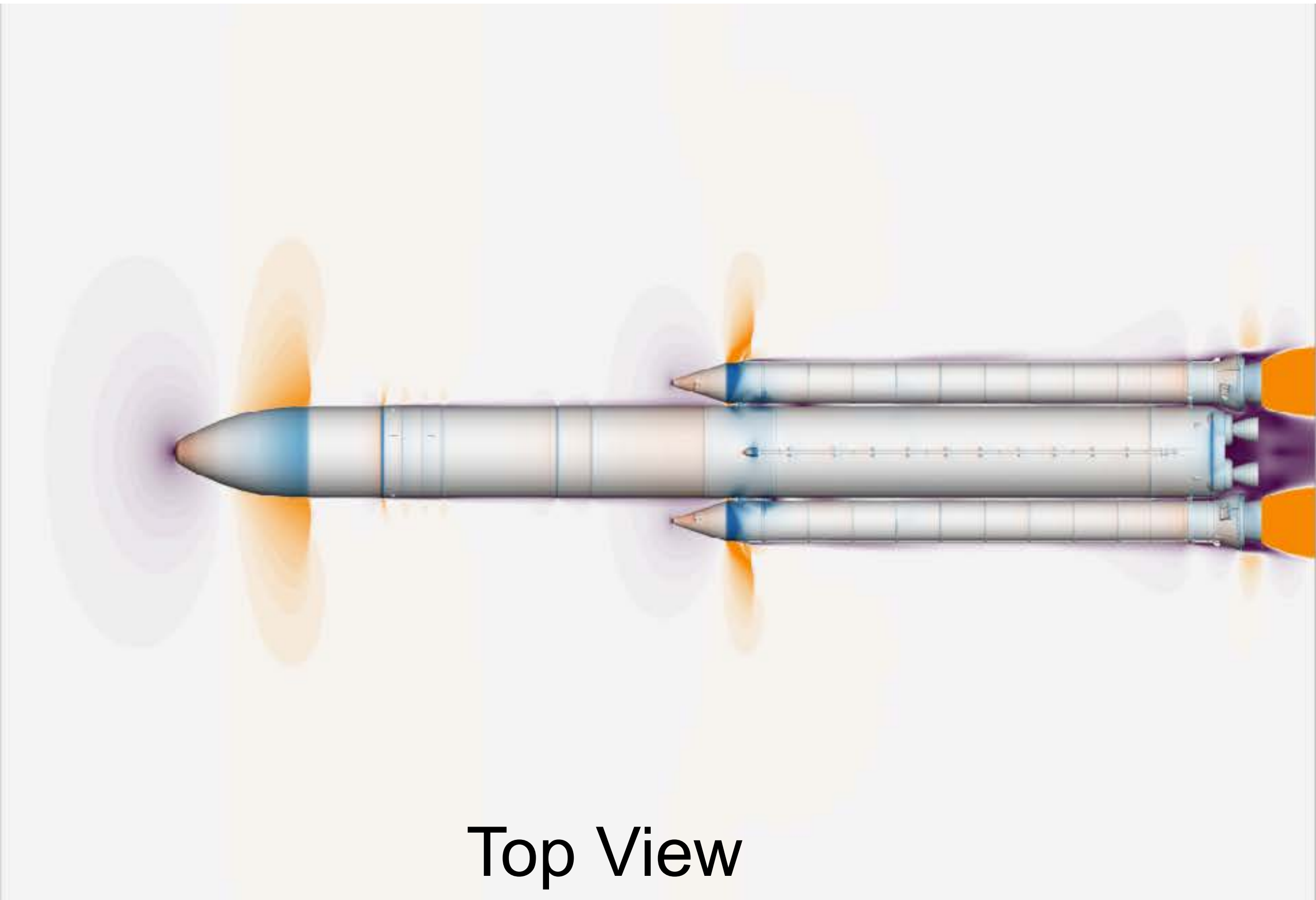

Background slice purple-green-white-orange color contours represent low to high velocities
Vehicle surface blue-white-red color contours represent low to high pressures

SLS Block 1B Cargo Ascent

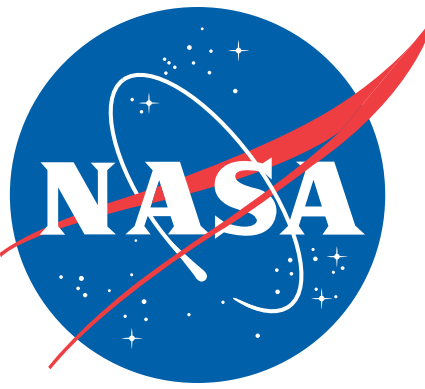

Altitude: Low • • • • • • • • • • • • • • • • High

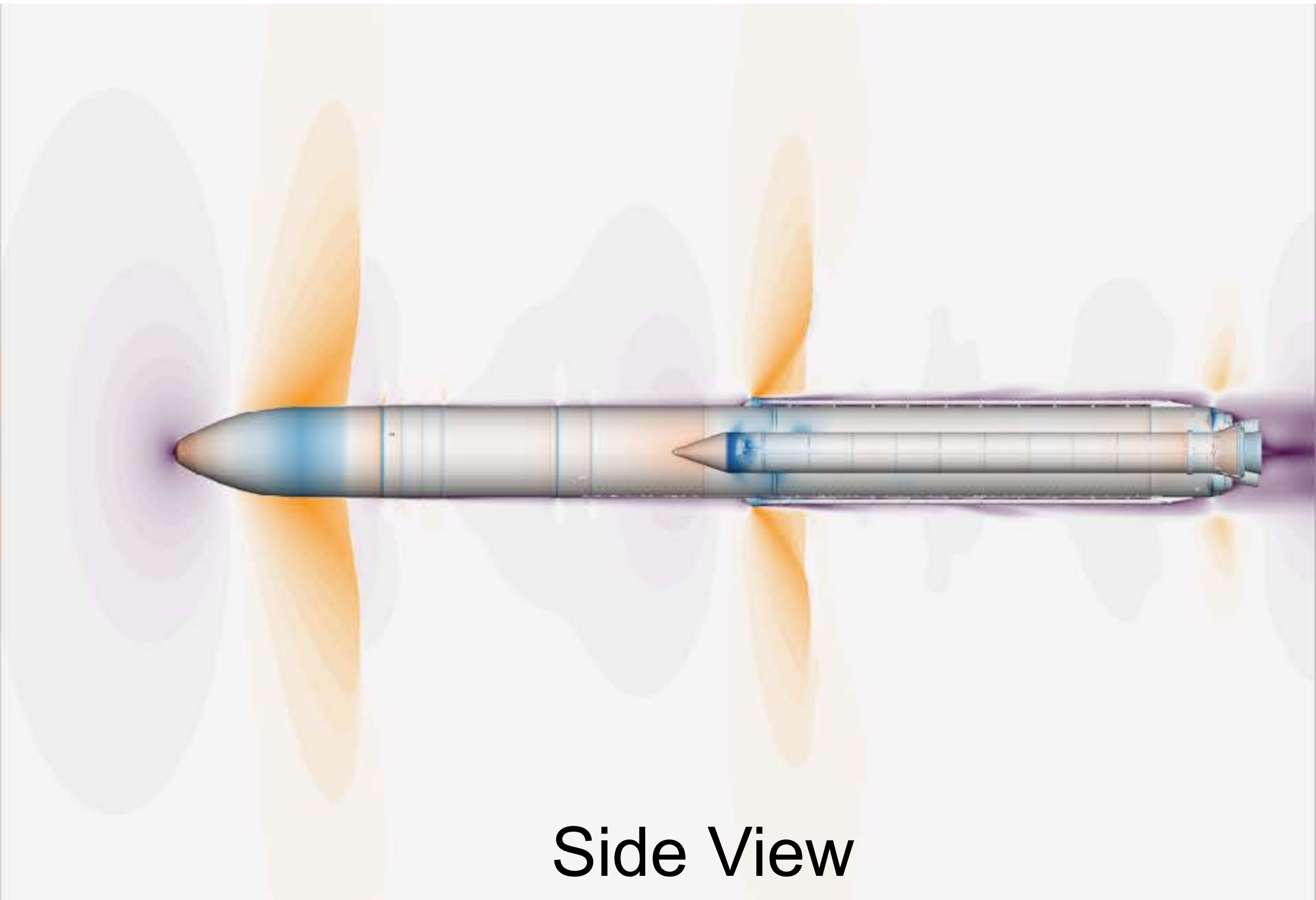
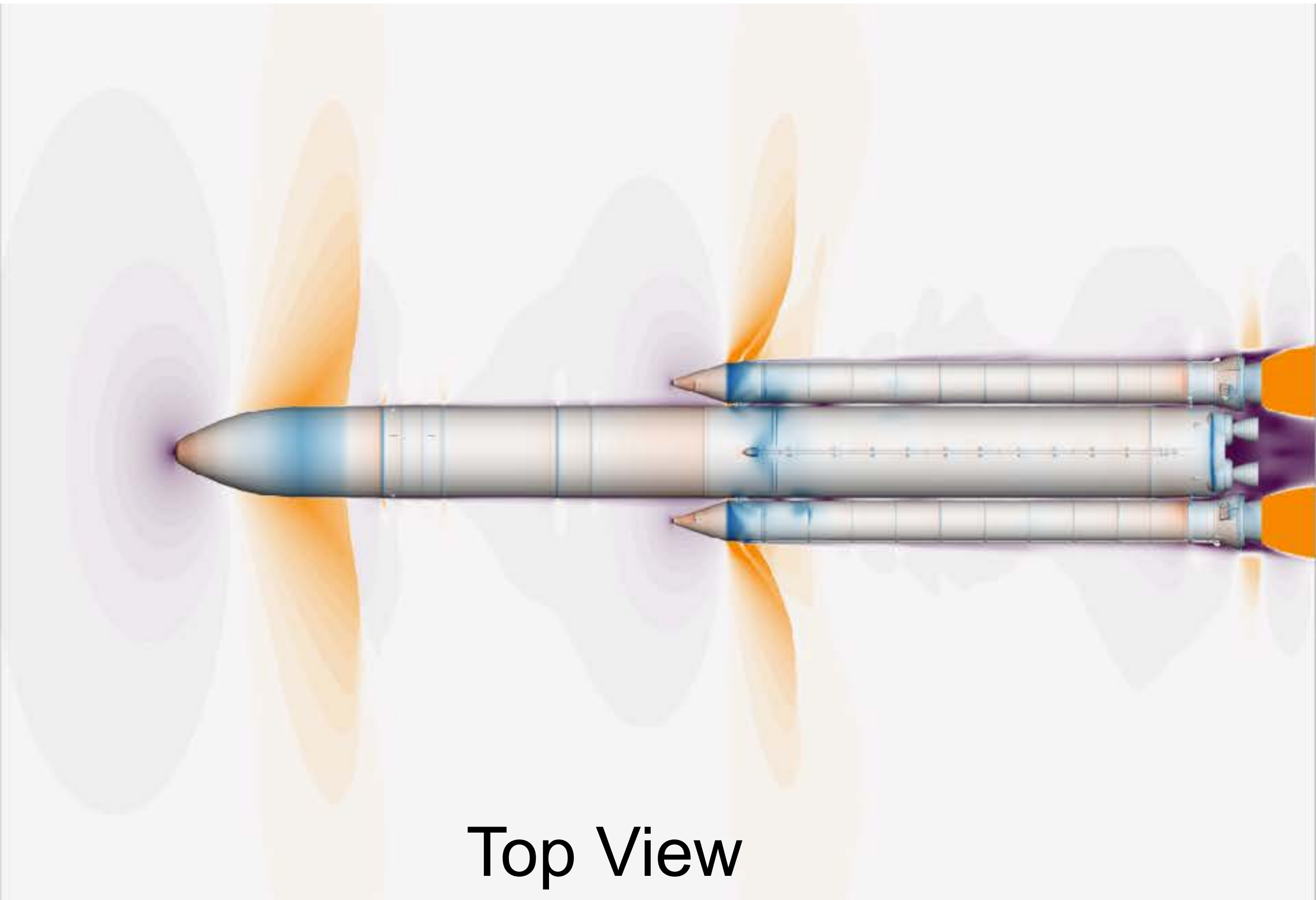

Background slice purple-green-white-orange color contours represent low to high velocities
Vehicle surface blue-white-red color contours represent low to high pressures

SLS Block 1B Cargo Ascent

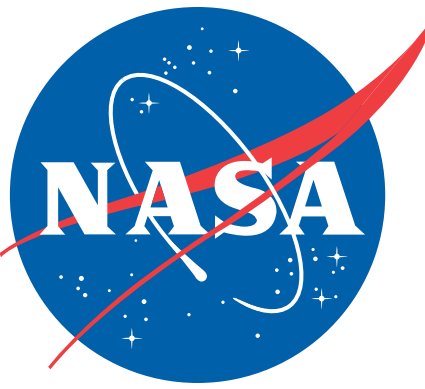

Altitude: Low • • • • • • • • • • • • • • High

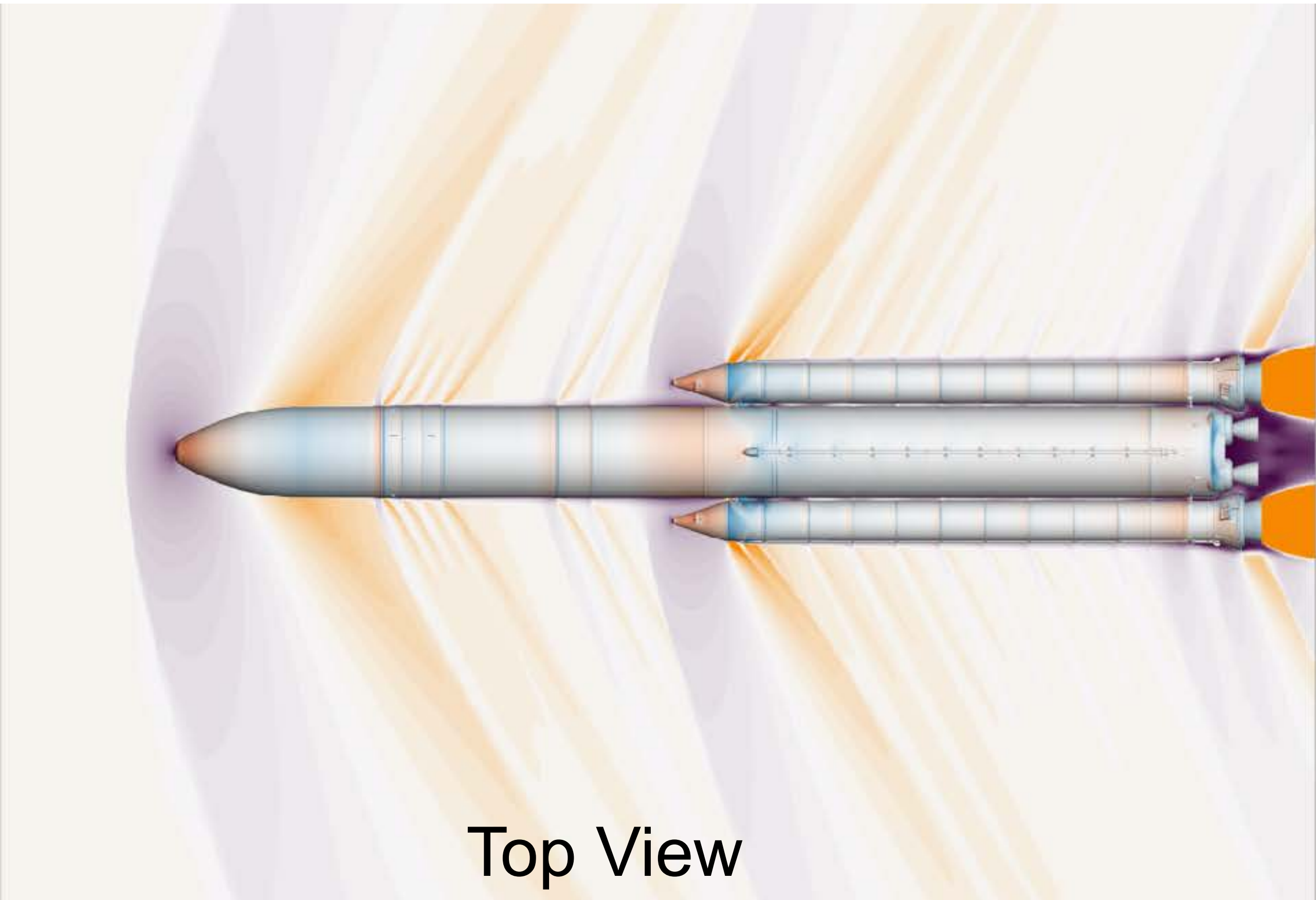

Top View

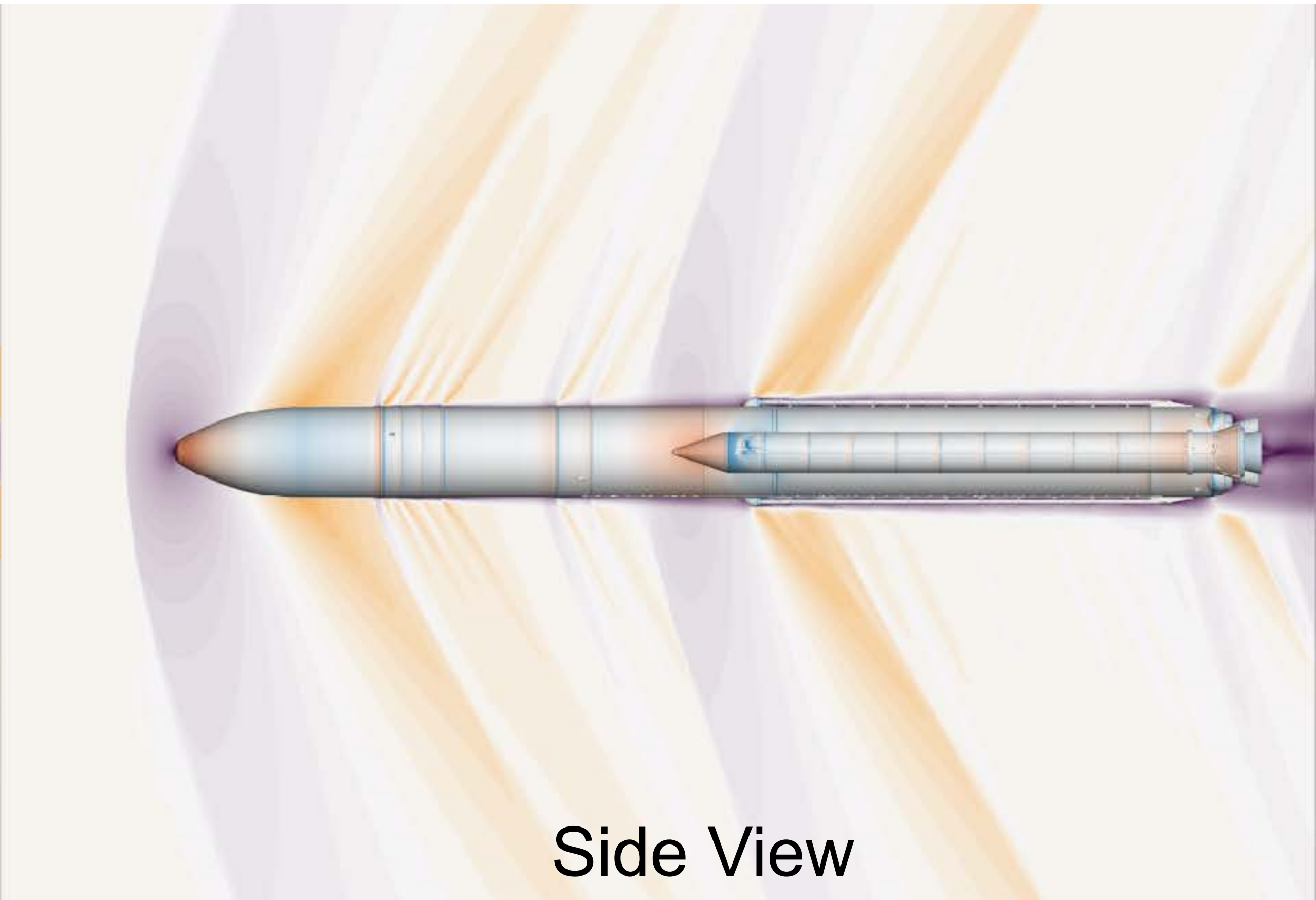

Side View

Background slice purple-green-white-orange color contours represent low to high velocities
Vehicle surface blue-white-red color contours represent low to high pressures

SLS Block 1B Cargo Ascent

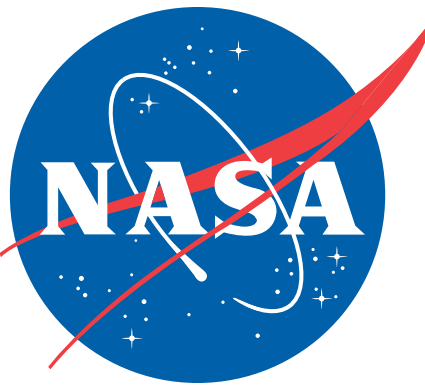

Altitude: Low • • • • • • • • • • • • • • • • High

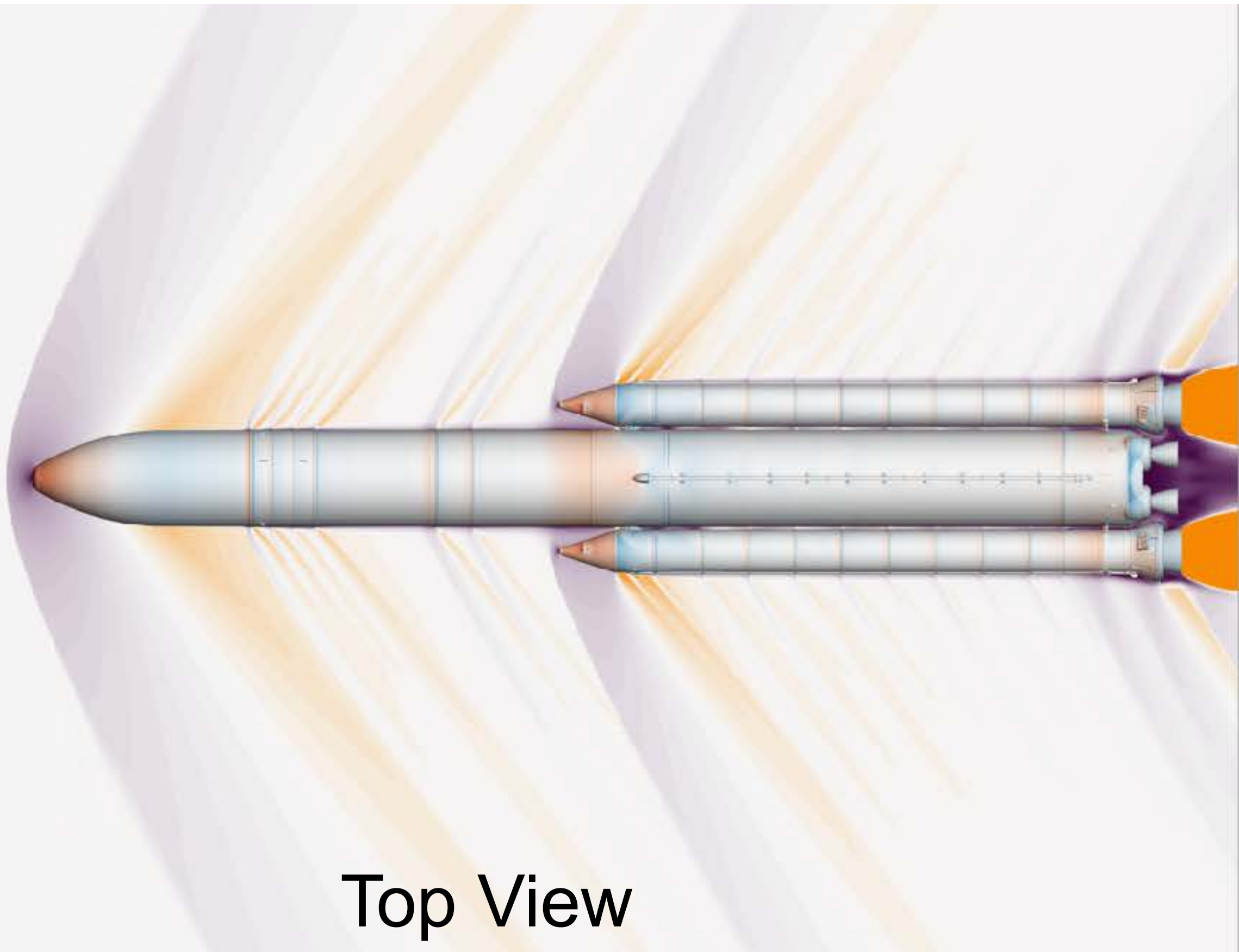

Top View

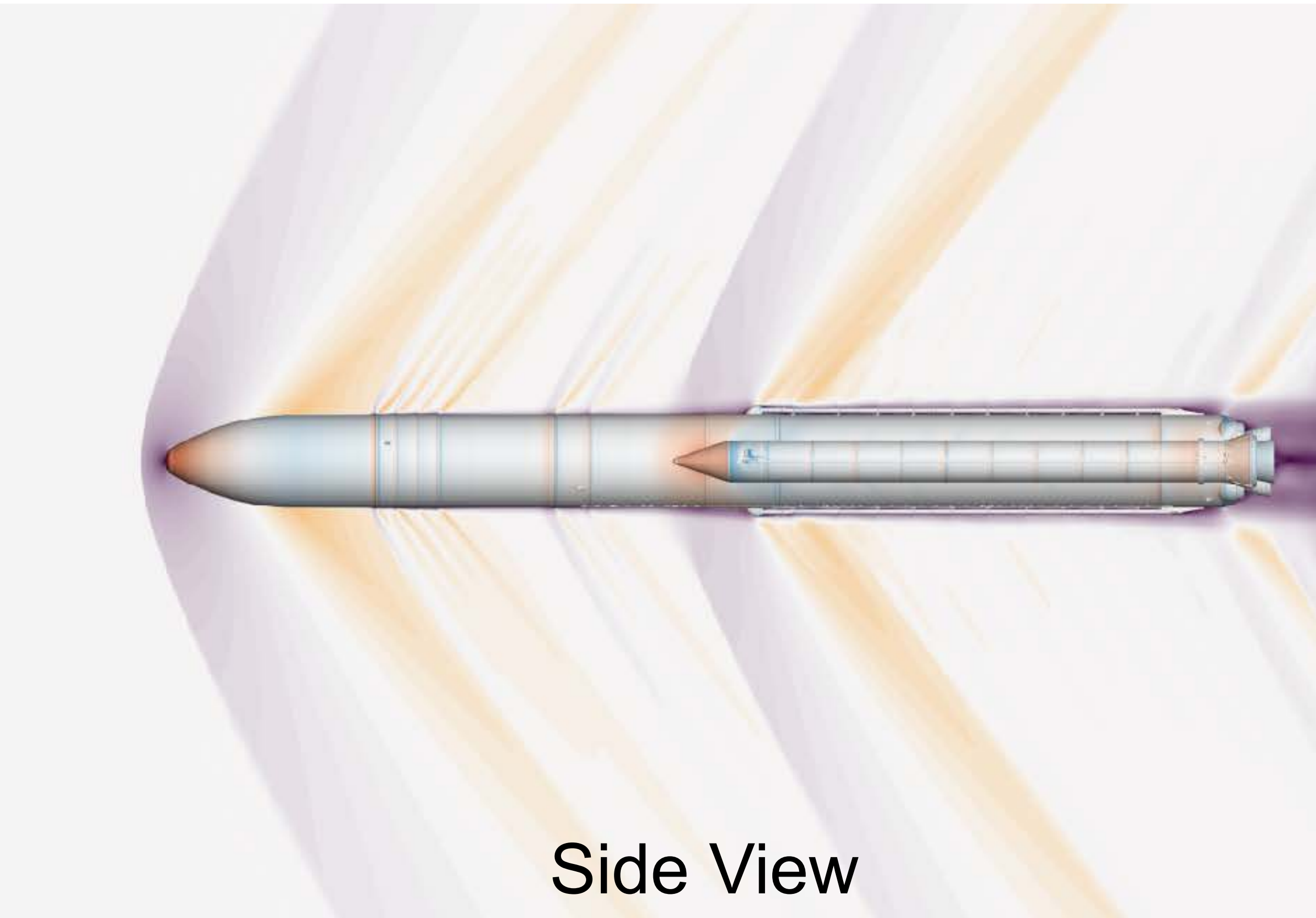

Side View

Background slice purple-green-white-orange color contours represent low to high velocities
Vehicle surface blue-white-red color contours represent low to high pressures

SLS Block 1B Cargo Ascent

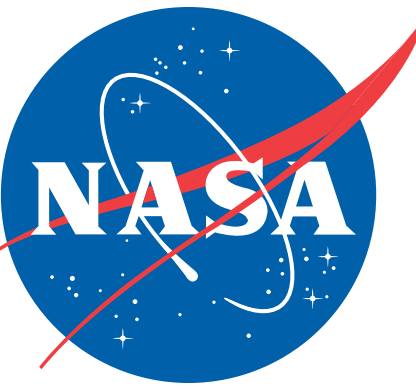

Altitude: Low • • • • • • • • • • • • • • • • High

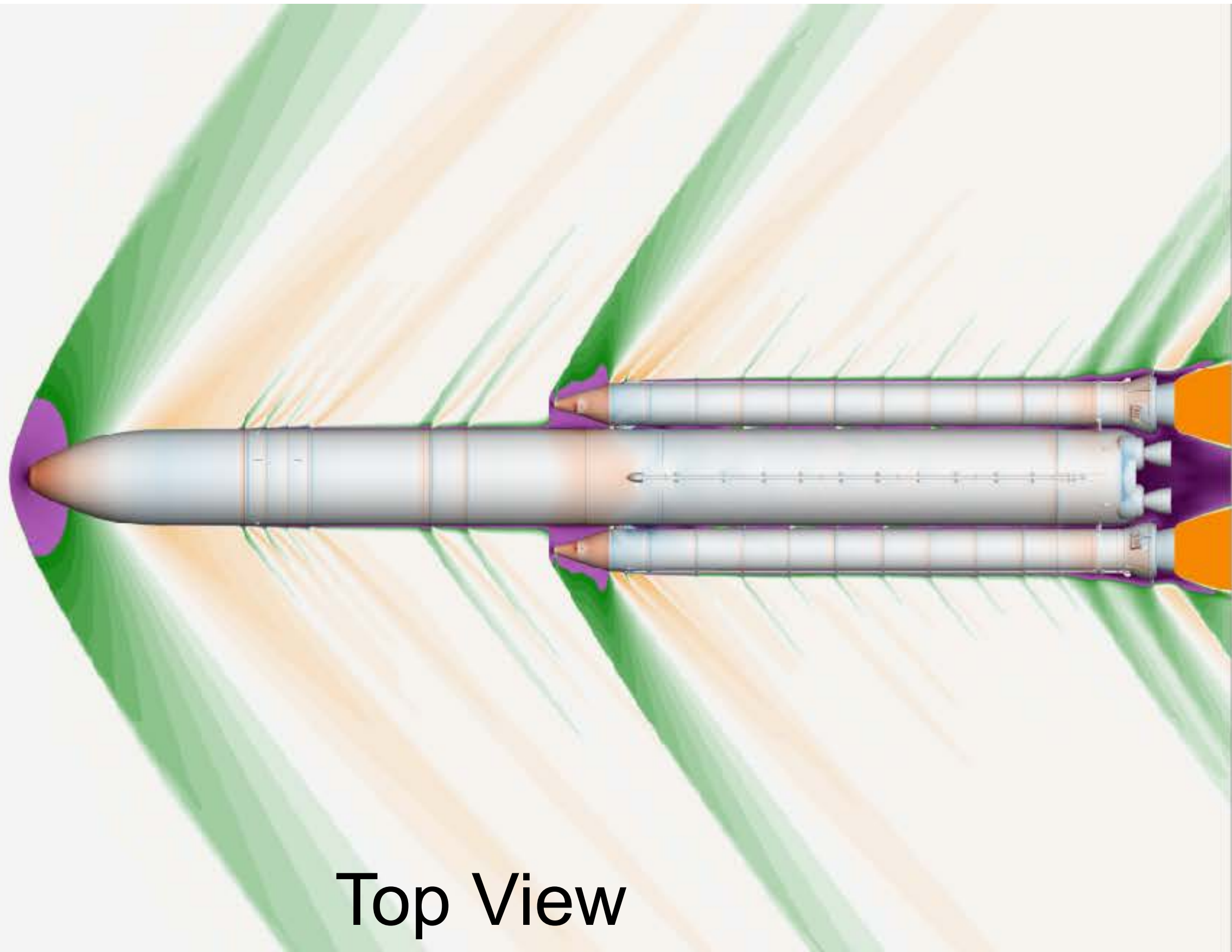

Top View

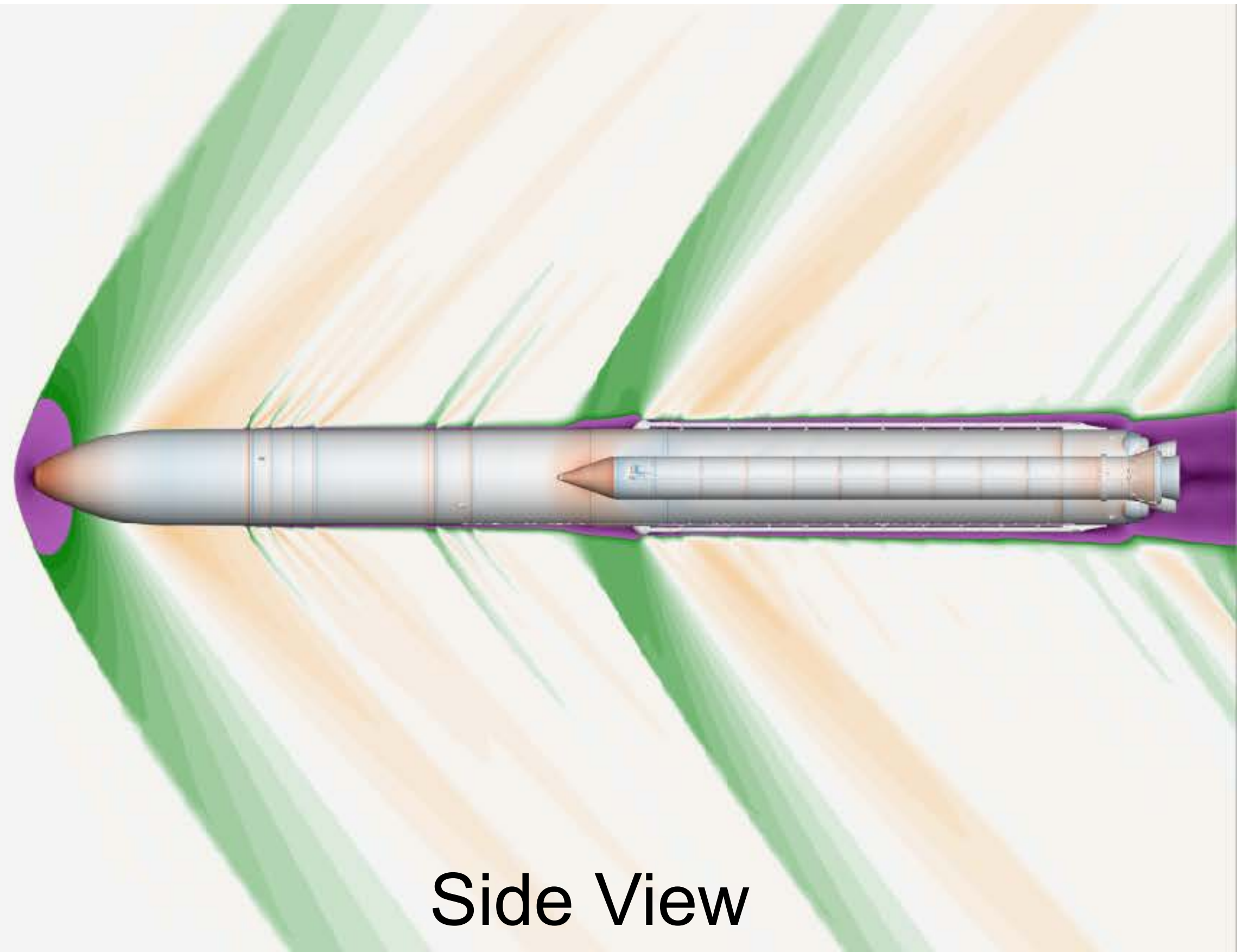

Side View

Background slice purple-green-white-orange color contours represent low to high velocities
Vehicle surface blue-white-red color contours represent low to high pressures

SLS Block 1B Cargo Ascent

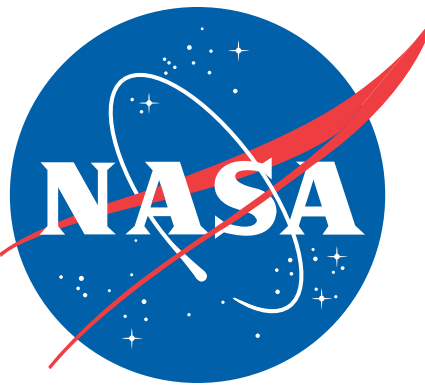

Altitude: Low • • • • • • • • • • • • • • • • High

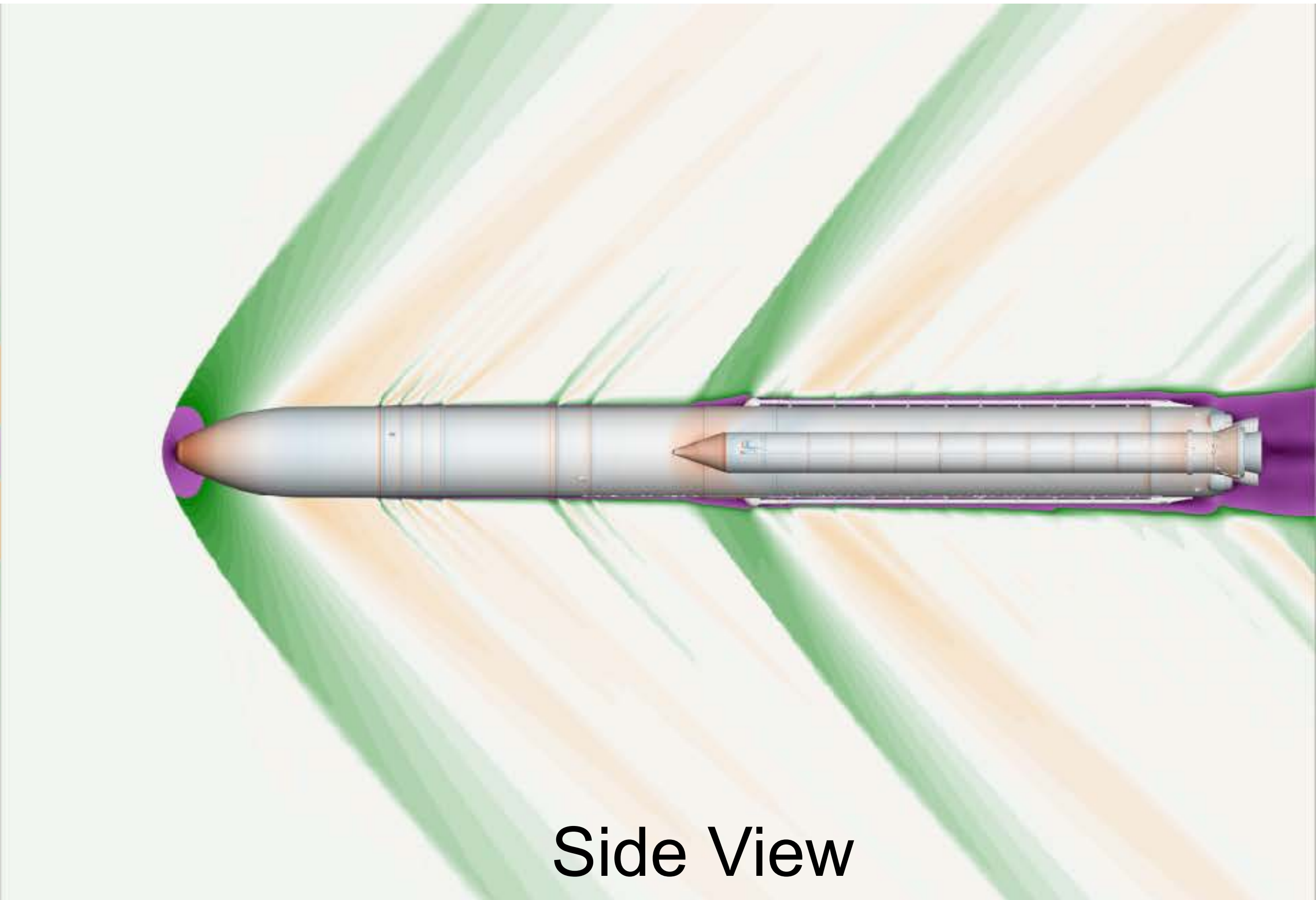
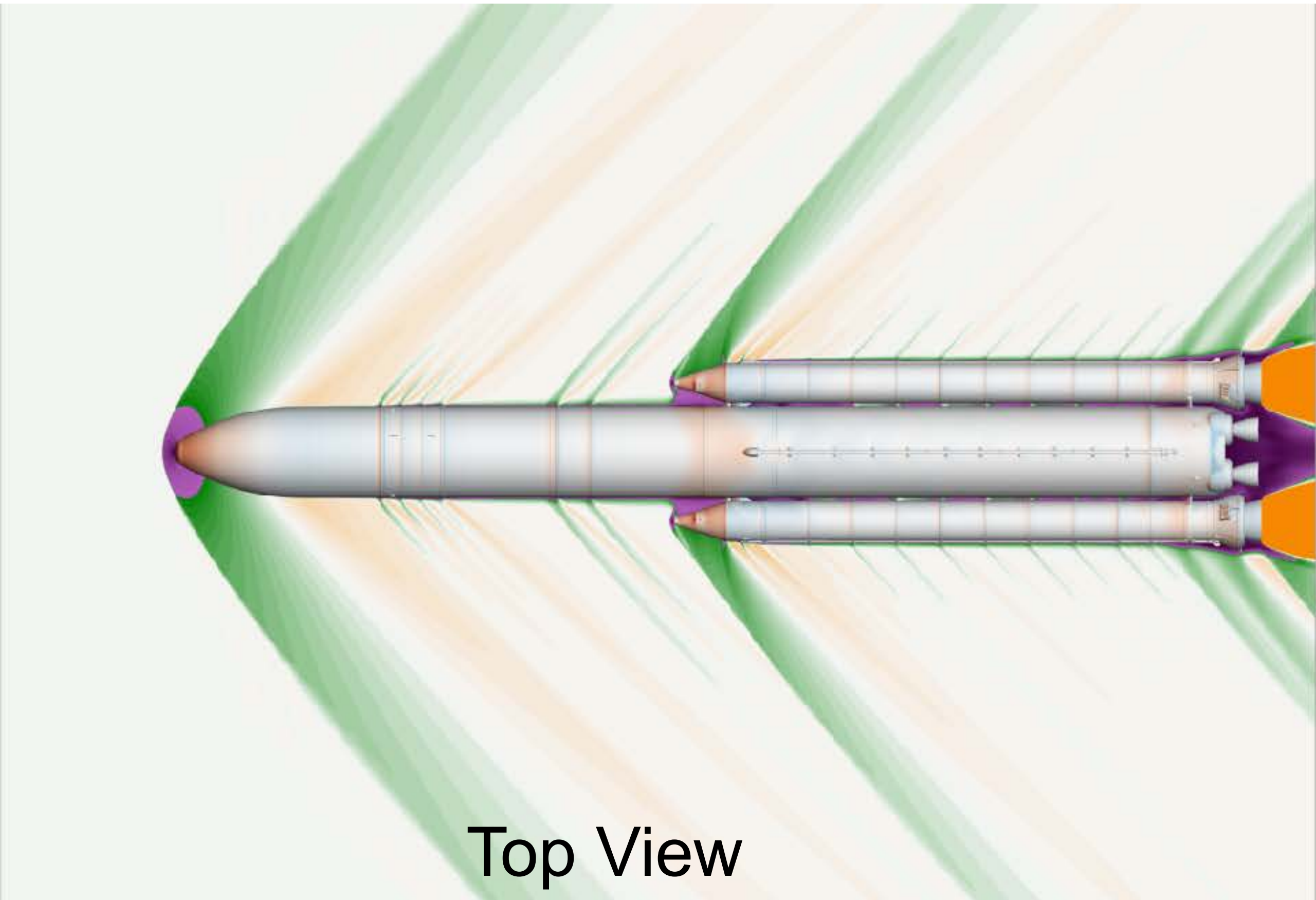

Background slice purple-green-white-orange color contours represent low to high velocities
Vehicle surface blue-white-red color contours represent low to high pressures

SLS Block 1B Cargo Ascent

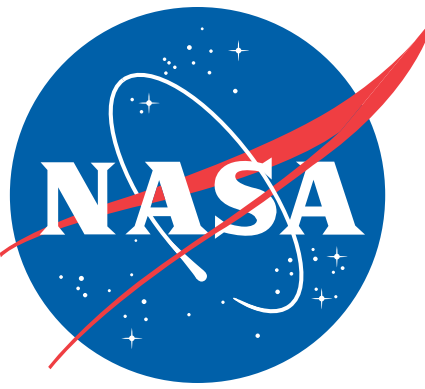

Altitude: Low • • • • • • • • • • • • • • • • • • High

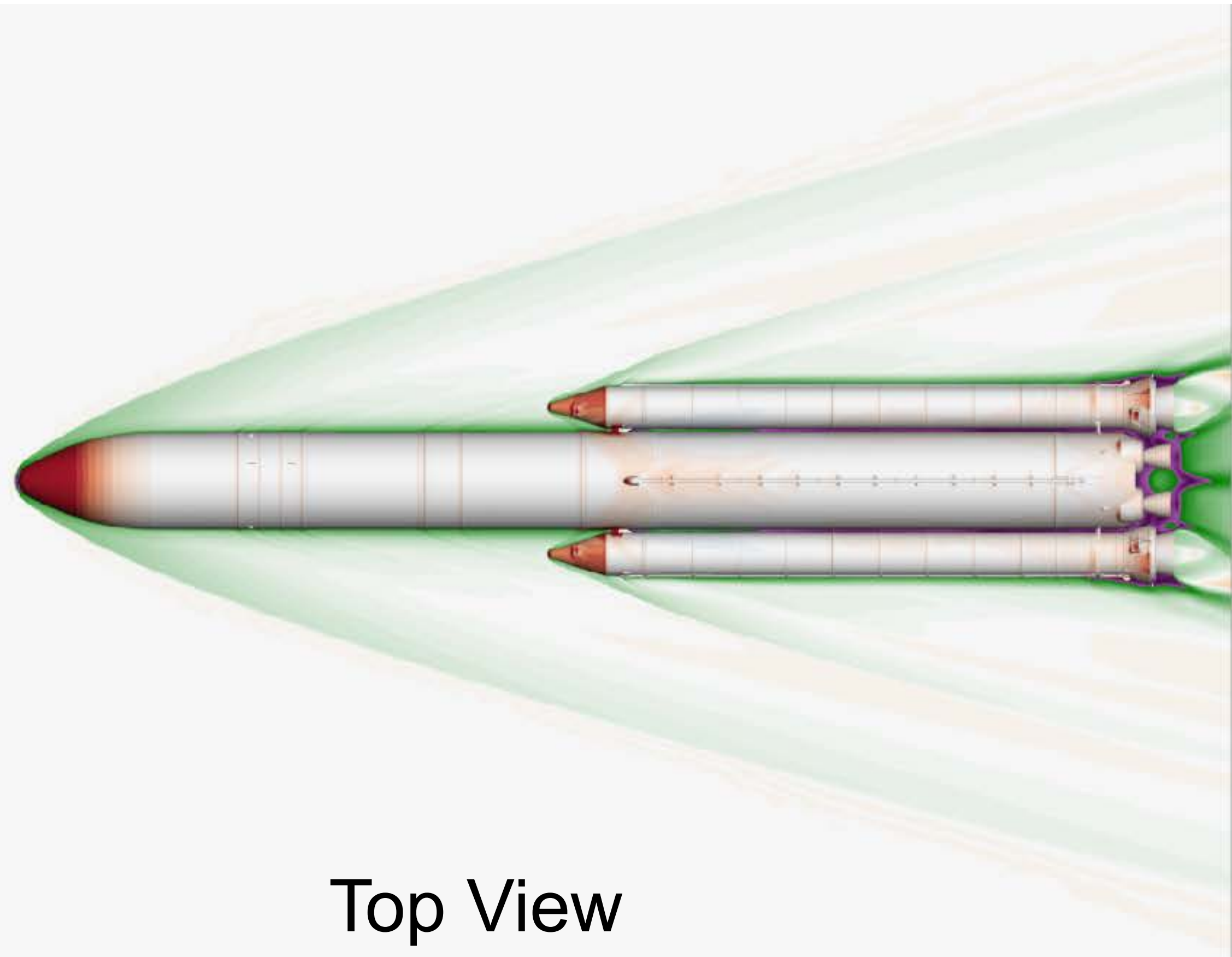

Top View

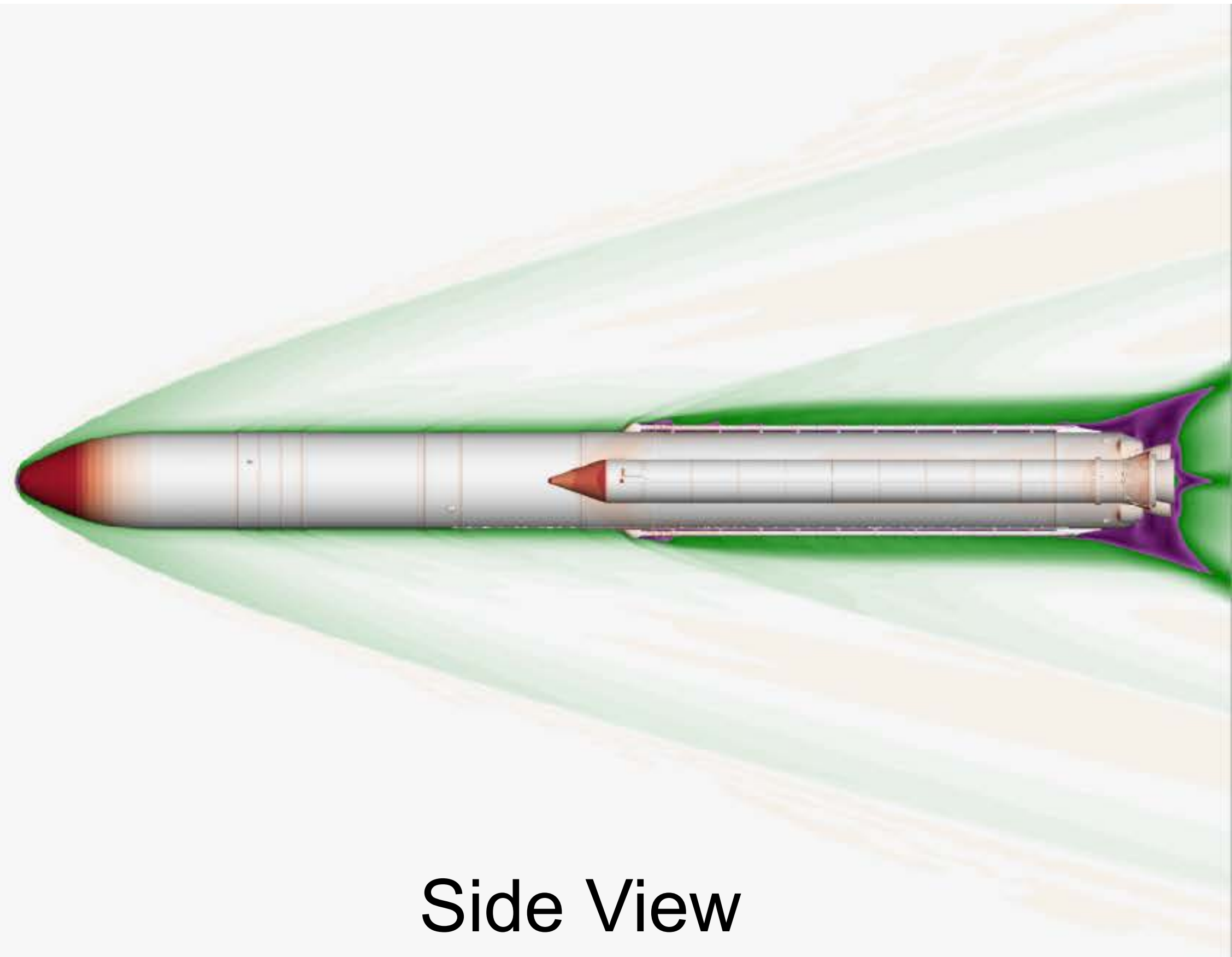

Side View

Background slice purple-green-white-orange color contours represent low to high velocities
Vehicle surface blue-white-red color contours represent low to high pressures

SLS Block 1B Cargo Ascent

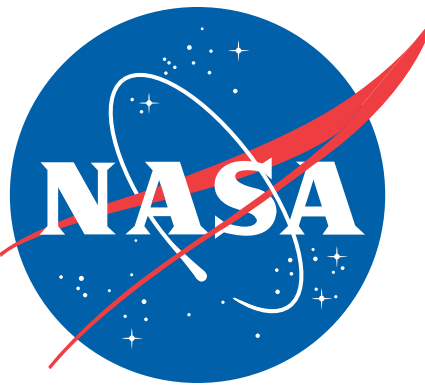

Altitude: Low • • • • • • • • • • • • • • • • • High

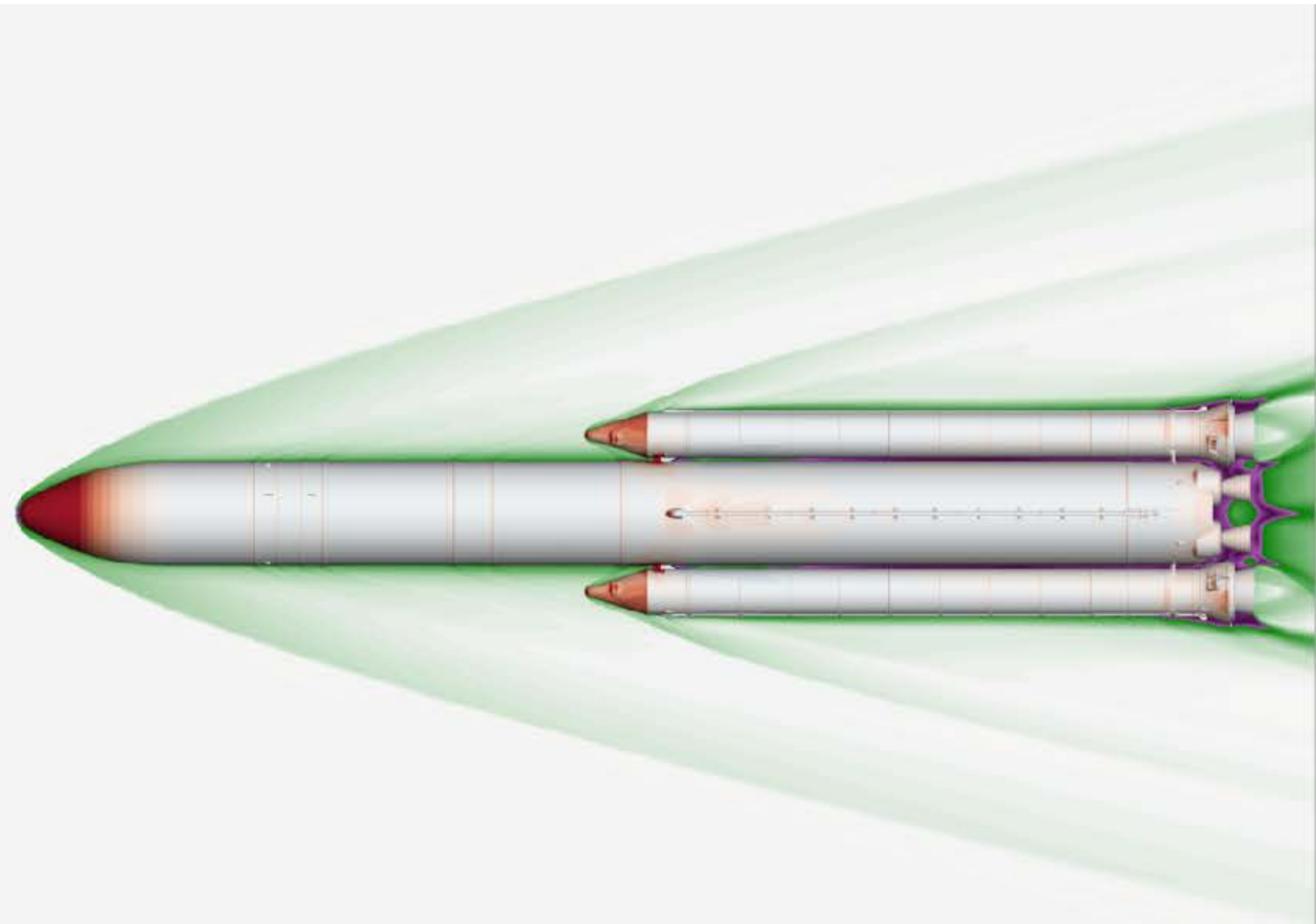

Top View



Side View

Background slice purple-green-white-orange color contours represent low to high velocities
Vehicle surface blue-white-red color contours represent low to high pressures

Conclusions

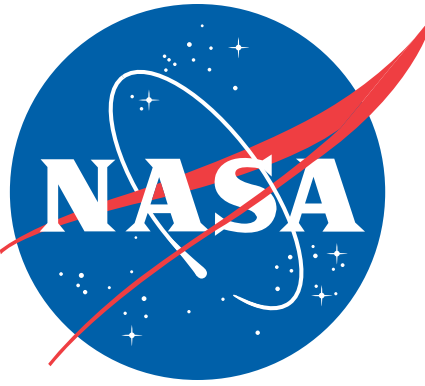

- NAS Pleiades Supercomputer enabled the creation of a CFD-based database for SLS booster separation
 - Created 4 aerodynamic databases for 3 vehicles
 - Over 71 Million core-hours over the last year
 - Over 8000 FUN3D cases
 - Over 1100 Overflow cases
 - Over 2.0 Million core-hours for moving body simulation to validate static-database method
- Successfully developed very complex aerodynamic databases
 - Most complex databases using CFD data in SLS program
 - Used extensively throughout the design process of the SLS rocket family