



Electrically Driven Thermal Management: Flight Validation, Experiment Development, Future Technologies

Jeffrey R. Didion
Senior Thermal Engineer
Manager, Nanotechnology Facility





Technical Overview

- **STP-H5 EHD Conduction Pump Life Test & Flight Demonstration: Jeffrey Didion NASA GSFC**
 - Demonstrated Long Term EHD Liquid Pumping Capability
 - Electric Driven Convection: viable Thermal Management Technology
- **Electrically Driven Liquid Film Boiling in the Absence of Gravity: Jamal Yagoobi WPI & Jeffrey Didion**
 - Feasibility of Liquid Film Boiling in Microgravity (ISS 2021 MSG Facility)
 - Demonstrate Liquid - Vapor Fluid Management in microgravity
 - Develop Numerical Models & Design Procedures
- **Future Technologies**
 - Electrospray Joel Chapman/Andrei Fedorov Georgia Tech: NSTRF Program
 - Micro/Nano Scale Electrically Driven Flow: Michal Talmor/Jamal Yagoobi WPI: NSTRF Program
 - Oscillating Heat Pipe (OHP): Joel Chapman/Jeffrey Didion/JenTung Ku





STP-H5 EHD Conduction Pump Life Test & Flight Demonstration

GSFC ISEM Package: PI Thomas Flatley/GSFC
EHD Experiment: PI Jeffrey Didion

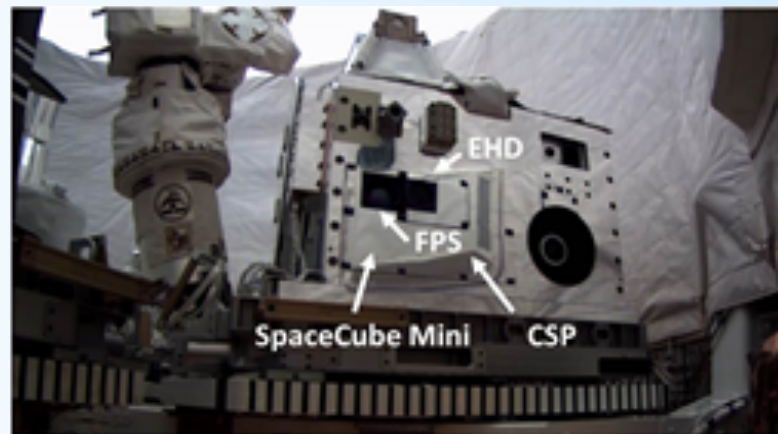

ISEM Package



STP-H5 EHD Conduction Pump Life Test & Flight Demonstration

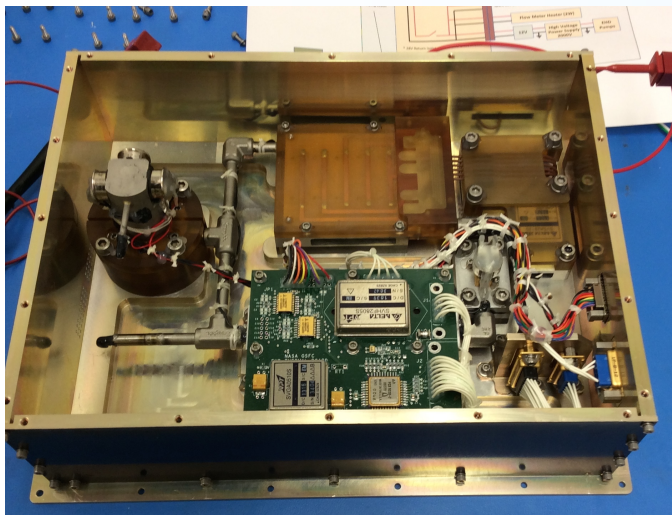

EHD Experiment

Experiment Significance

- **Demonstrate Electrically Driven Convection as feasible technology**
 - Engineering subsystems
 - Flow Control
- **GSFC Manufacturing Advances**
 - Higher pressure head pumps
 - Two Phase Systems (ISS FBCE Experiment Mudawar/Hasan)
- **Future Technology Development**
 - Higher Heat Flux Applications
 - Small Scale Applications





STP-H5 EHD Conduction Pump Life Test & Flight Demonstration

EHD Experiment Pump Performance

- 1000 Vdc applied
- Intermittent Operation at ISEM discretion
- Consistent Operation: no apparent fluid degradation

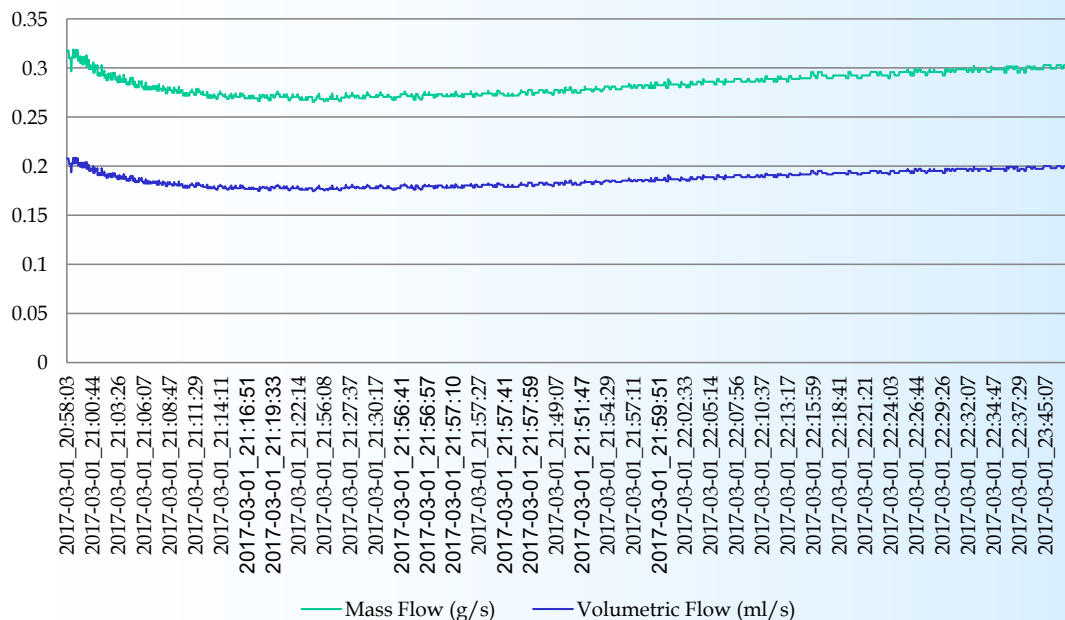



STP-H5 EHD Conduction Pump Life Test & Flight Demonstration

EHD Experiment Loop Set Point

- Two Phase Reservoir: HFE7100 Working Fluid
- Thermal Controller

STP-H5 Inlet, Outlet and Reservoir Temperatures

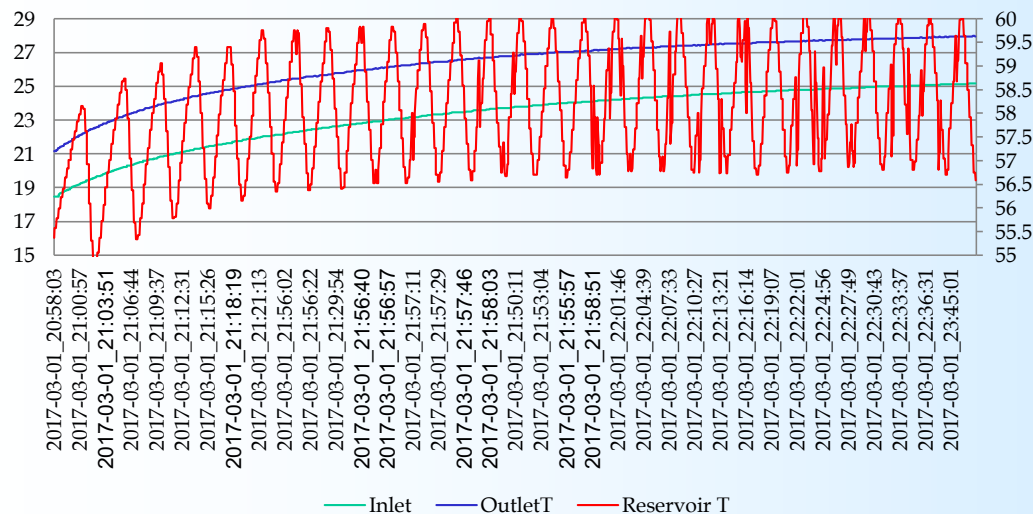



EHD Conduction Pumping

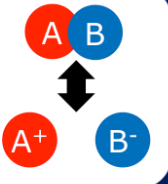

Molecules dissociate into positive and negative ions, while ions recombine into neutral molecules. When electrical field intensity is low, dissociation & recombination rates are in dynamic equilibrium.

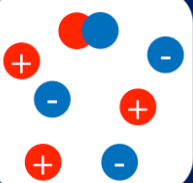

High electric field intensity causes the rate of dissociation to exceed the rate of recombination.

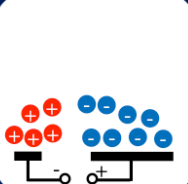

These charges redistribute due to the electric field, forming heterocharge layers. The attraction of charges to the nearby electrode causes fluid motion. By designing electrodes to produce asymmetry of electric field, net flow results.





Higher Pressure EHD Conduction Pumps

EHD Conduction Phenomena

- Geometry Dependent
- Advanced Manufacturing Techniques: Smaller Size & Lower Applied Voltage

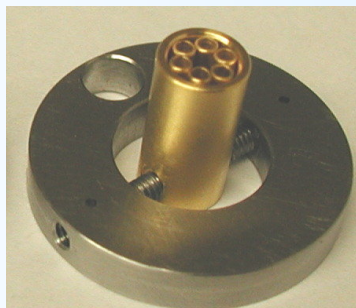
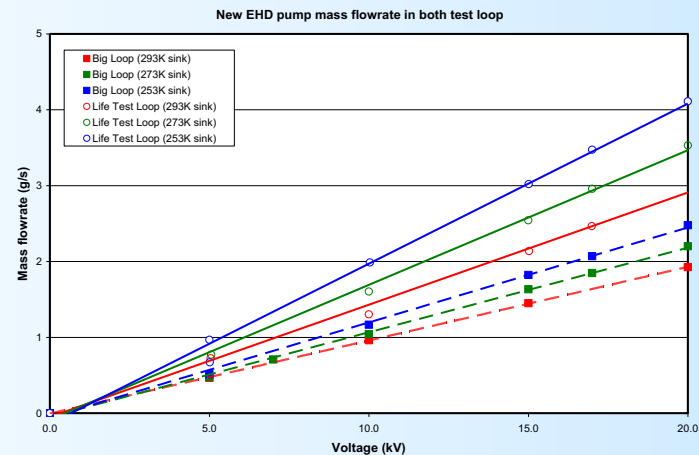
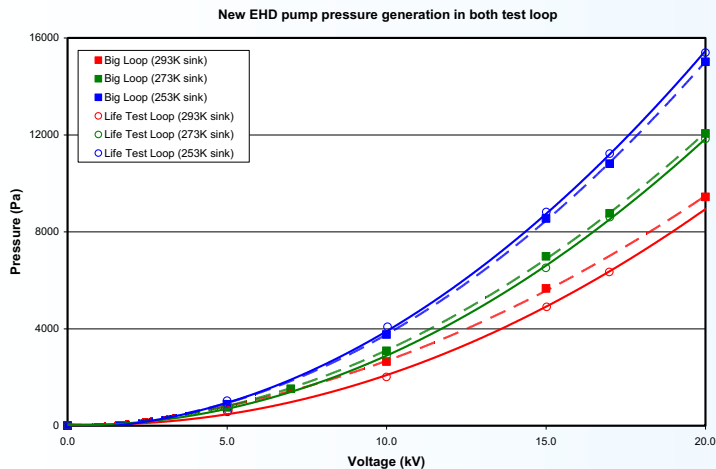



Electrically Driven Liquid Film Boiling Experiment:

Objective:

- ♦ Characterize the effects of gravity on the interaction of electric and flow fields in the presence of phase change specifically pertaining to:
 - The effects of microgravity on the electrically generated two-phase flow.
 - The effects of microgravity on electrically driven liquid film boiling (includes extreme heat fluxes).
- ♦ Electro-wetting of the boiling section will repel the bubbles away from the heated surface in microgravity environment.

Relevance/Impact:

- ♦ Provides phenomenological foundation for the development of electric field based two-phase thermal management systems leveraging EHD, permitting optimization of heat transfer surface area to volume ratios as well as achievement of high heat transfer coefficients thus resulting in system mass and volume savings.
- ♦ EHD replaces buoyancy or flow driven bubble removal from heated surface.

Development Approach:

- ♦ Conduct preliminary experiments in low gravity and ground-based facilities to refine technique and obtain preliminary data for model development.
- ♦ ISS environment required to characterize electro-wetting effect on nucleate boiling and CHF in the absence of gravity.
- ♦ Microgravity Science Glovebox (MSG – 2021)

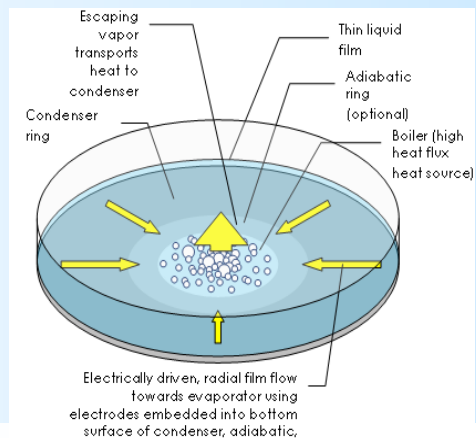
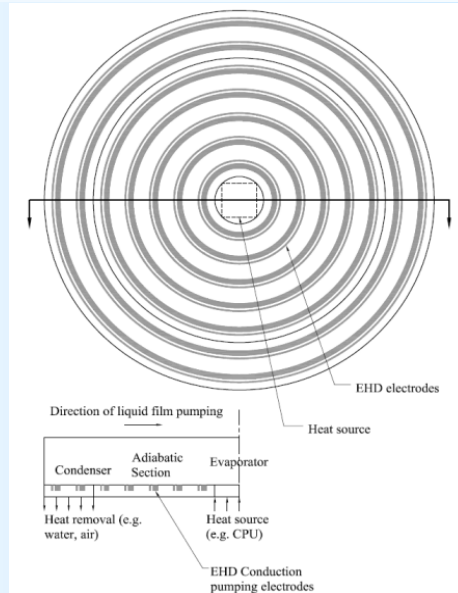



Electrically Driven Liquid Film Boiling Experiment: Fluid Management

Objective:

- Investigate combined effect of Dielectrophoretic Force and Electrophoretic Force (Conduction Mechanism) on heat transfer enhancement

$$F_{DEP} = 2\pi a^3 \epsilon_1 \left(\frac{\epsilon_2 - \epsilon_1}{\epsilon_2 + 2\epsilon_1} \right) \nabla |E_e|^2$$

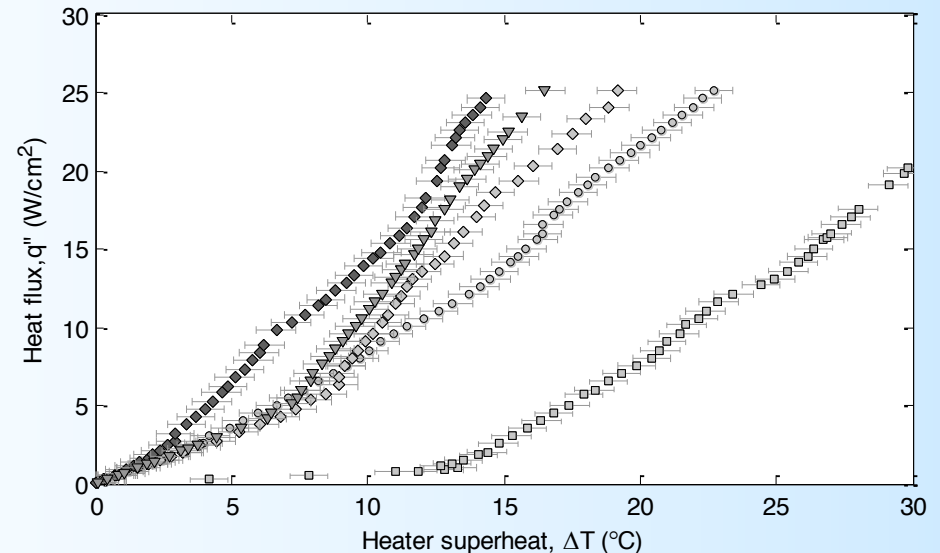
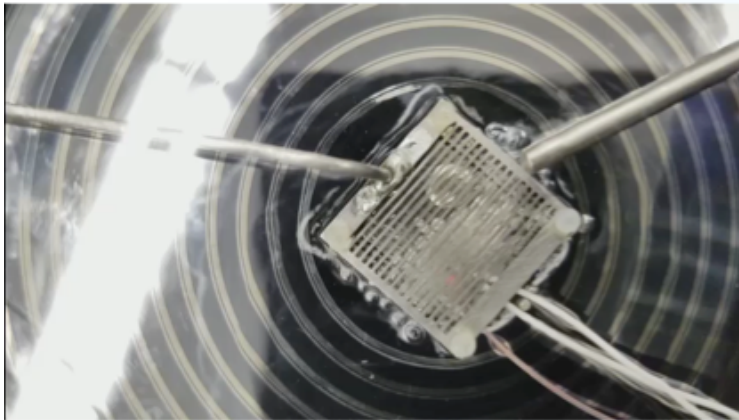

□	2 mm liq. film, 0 kV applied EHD potential, DEP electrode removed, P _{sat} =80.0 kPa, T _{sat} =21.5 °C
○	2 mm liq. film, 0 kV applied EHD potential, 2.5 kV applied DEP potential, P _{sat} =78.2 kPa, T _{sat} =20.9 °C
△	2 mm liq. film, 1.5 kV applied EHD potential, 2.5 kV applied DEP potential, P _{sat} =78.5 kPa, T _{sat} =21.0 °C
◇	2 mm liq. film, 2.0 kV applied EHD potential, 2.5 kV applied DEP potential, P _{sat} =78.8 kPa, T _{sat} =21.1 °C
▽	10 mm liq. pool, 0 kV applied EHD potential, 2.5 kV applied DEP potential, P _{sat} =79.7 kPa, T _{sat} =21.4 °C





Electrically Driven Liquid Film Boiling Experiment: EHD - DEP Phenomena

$$f_e = \underbrace{\rho_e \mathbf{E}}_{\text{Coulomb Force}} - \underbrace{\frac{1}{2} E^2 \nabla \epsilon + \frac{1}{2} \nabla \left[E^2 \left(\frac{\partial \epsilon}{\partial \rho} \right)_T \rho \right]}_{\text{Polarization Forces}}$$

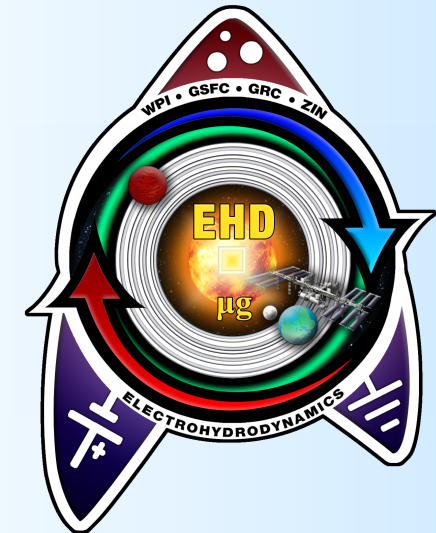

Di-Electrophoretic Force enables and enhances liquid film boiling

$$F_{DEP} = 2\pi a^3 \epsilon_1 \left(\frac{\epsilon_2 - \epsilon_1}{\epsilon_2 + 2\epsilon_1} \right) \nabla |E_e|^2$$

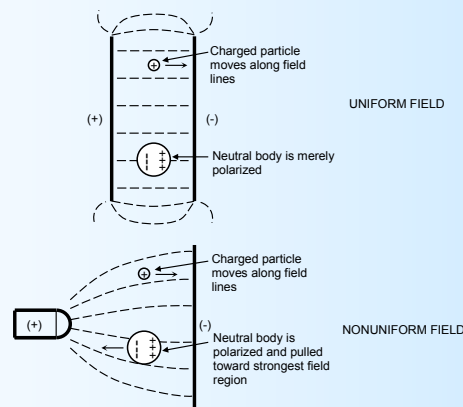



Electrically Driven Liquid Film Boiling Experiment: Hardware Development

Science Validation Loop

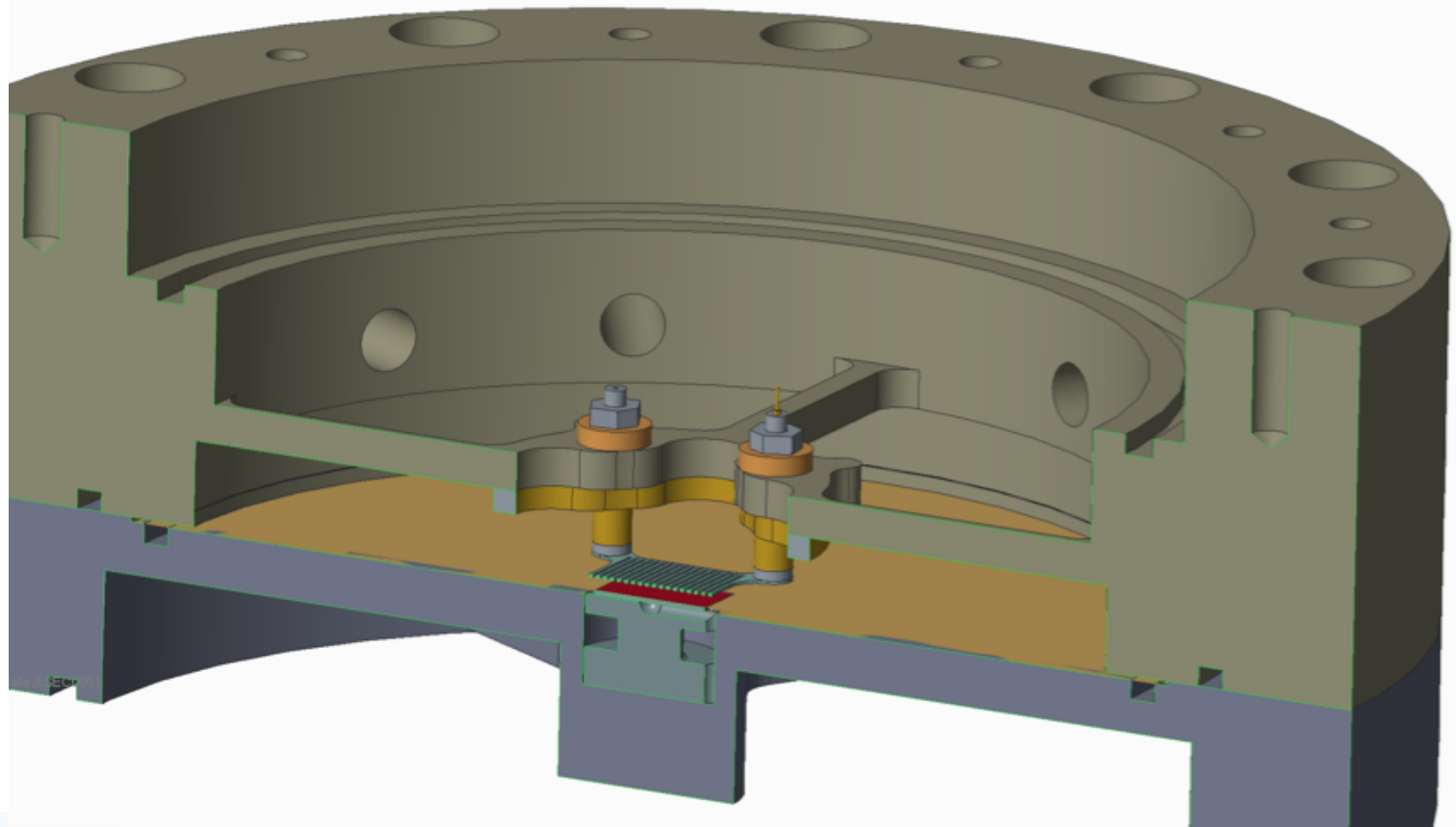



Electrified Liquid Jets for Evaporative Heat Transfer Enhancement

Joel Chapman, Peter Kottke, Andrei Fedorov

This work was supported by NASA Space Technology Research Fellowship, Project Number NNX16AM95H.





Electrospray Background

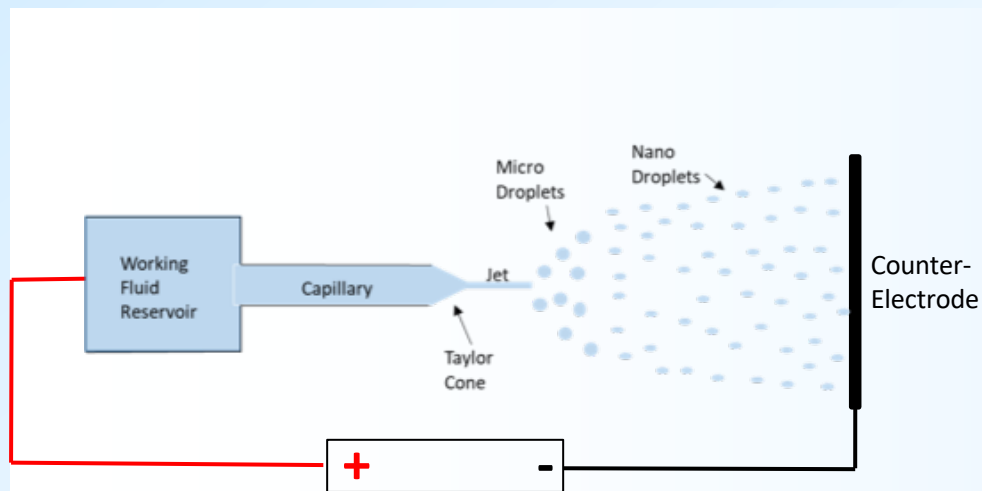

- *Charged ions are forced out of the capillary opening by the electric field, shaping the liquid into a cone (known as a Taylor Cone) at the tip.*
- *Cone becomes unstable and produces a narrow spray jet.*
- *Due to Coulombic repulsion between the charged ions, the jet spreads and breaks into a plume of nano-scale droplets.*
- *Electric field drives droplets to counter-electrode.*

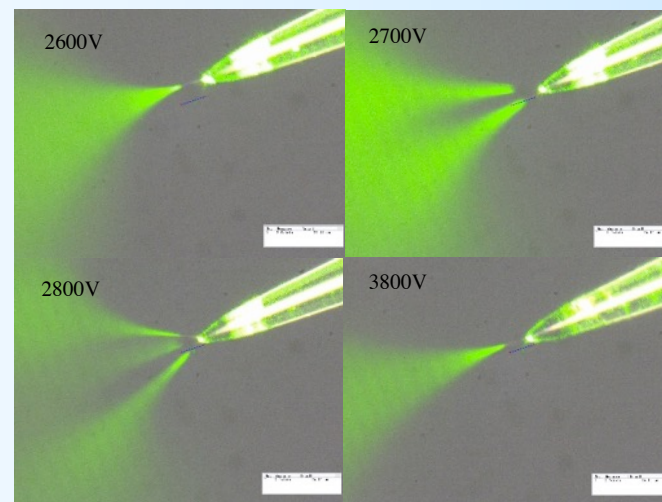

Effect of electrostatic potential on spray geometry

1000 nL/min spray flow of DI water with 0.1% acetic acid dopant through a 3.25 μm ID fused silica capillary at spray voltages noted above. Small blue/red reference lines shown near the capillary tip in each photo are approximately 24 μm long. Images taken at 1000x using Keyence 500f microscope. Spray plume illuminated using a laser. The counter electrode was Indium Tin Oxide (ITO)-coated polished float glass placed approximately 2mm from the capillary tip.





Liquid Impinging on Indium Tin Oxide Test Device for Film Visualization Experiments

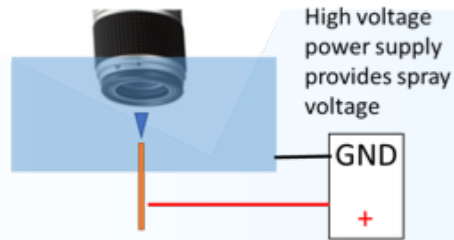
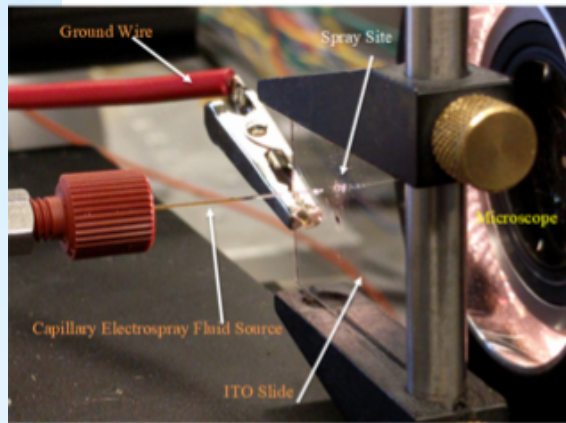

Transparent ITO permits viewing of spray from opposite side of substrate, normal to surface

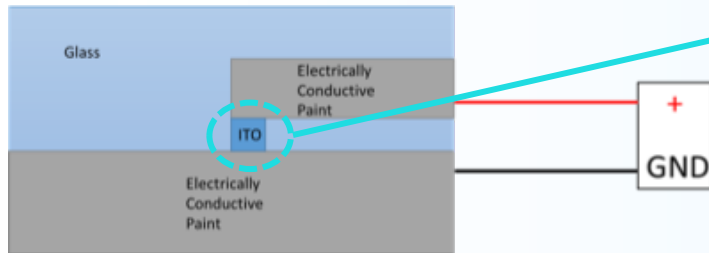

Reducing actively heated ITO area limits resistive heat production to area under spray (1.4 x 1.4 mm)

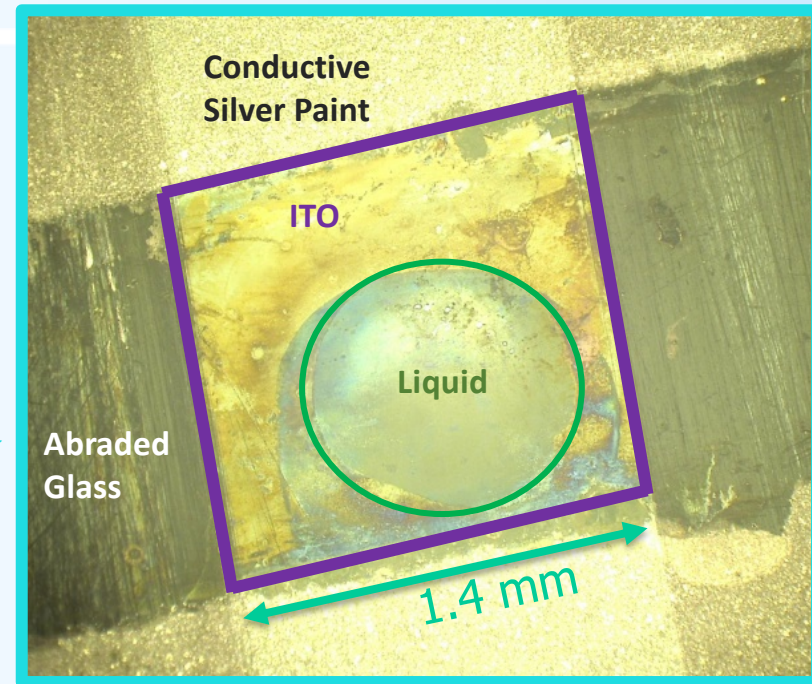



ES Impingement Permits Film Shape Control

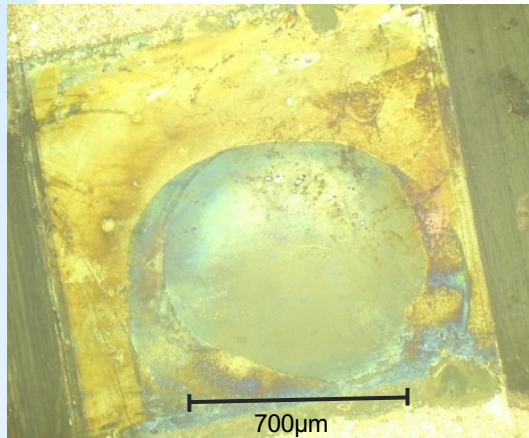

Dome

Low ES voltage or distant spray.

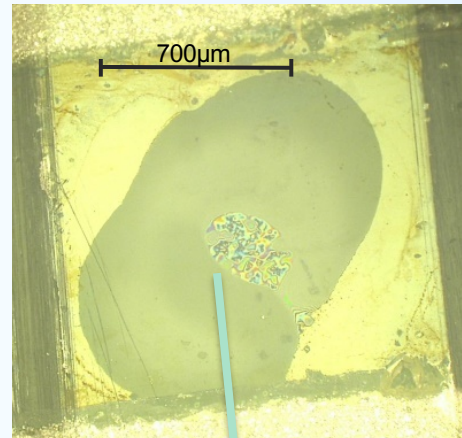

Torus

High ES voltage, spray source near substrate.

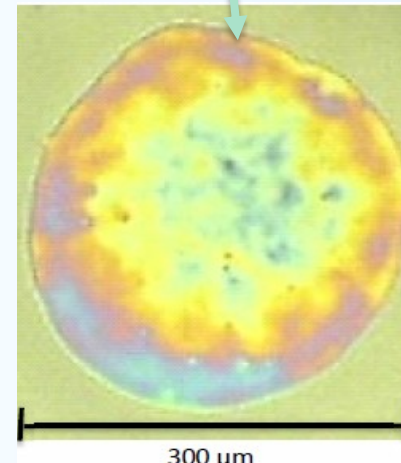

Thin Film

Significant thinning of film under the impingement site for high ES voltage. Color banding is due to light interference patterns, not post-processing. Films seen here less than 350nm thick.

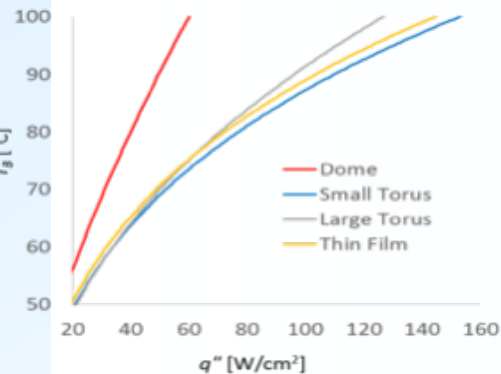

- Creating thin films using electro-spray impingement reduces conduction resistance.
- Modeling predicts significant thermal performance improvement by impingement-flattening.

$h_m = 1 \text{ m/s}$ ($h = 1000 \text{ W/m}^2\text{K}$)
 $T_{inf} = 25 \text{ }^\circ\text{C}$
 50% relative humidity





Microfabricated Test Devices, Experiments

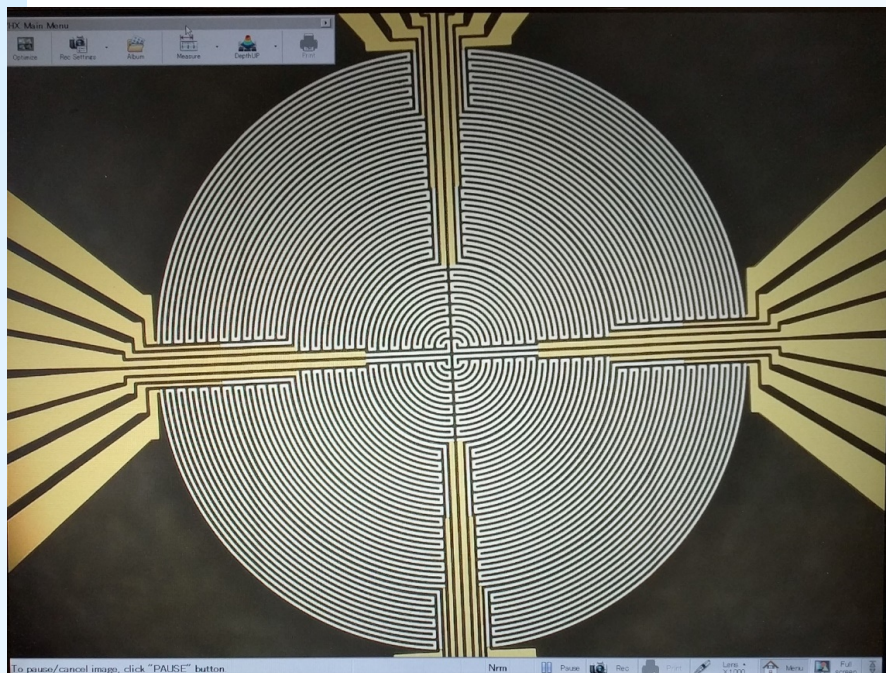

Microfabricated 16-RTD array at 100x

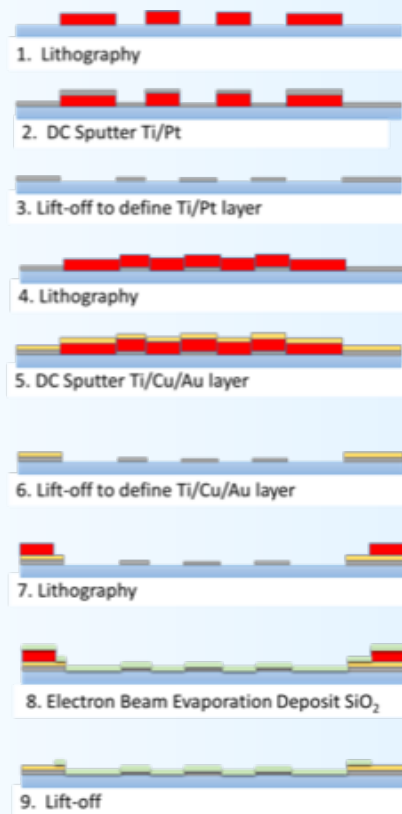

- Experiments on microfabricated test devices corroborate the hypothesis that high-ES impingement yields greatly improved evaporative heat transfer enhancement.
- Using methanol as ES working fluid, dissipated 245 W/cm^2 from $<100^\circ\text{C}$ hotspot.





STUDY OF MICRO/NANO SCALE EHD-DRIVEN FLOW DISTRIBUTION CONTROL & HEAT TRANSFER ENHANCEMENT FOR THERMAL CONTROL SYSTEMS

Recipient: Michal (Michelle) Talmor, Advisor: Jamal Yagoobi

- **Goal of NSTRF Project:**

- Study flow distribution control behavior and smart, active heat transfer enhancement utilizing Electrohydrodynamic (EHD) conduction pumps at multiple size scales, in single and two-phase flows
- Study the underlying electrochemical charge formation processes present in EHD conduction pumping, and how they are affected by pumping orientations and externally applied loads
- Obtain fundamental understand the effect of temperature on the EHD conduction pumping mechanism
- Obtain scaling laws and recommended design practices for EHD conduction driven flow distribution systems at different size scales, for different operational conditions





Theoretical Work: Simulated Heterocharge Layer Morphology

- Externally applied flow
- Two electrode pairs
- Max. voltage of 1500V

In forward orientation:

- EHD pump is parallel to the main flow
- Diminishing layer height on subsequent electrode pairs
- Eroded layer heights with higher incoming flow velocity

In reversed configuration:

- EHD pump is acting against the main flow
- Increasing layer height on subsequent electrode pairs
- Increased layer heights with higher incoming flow velocity

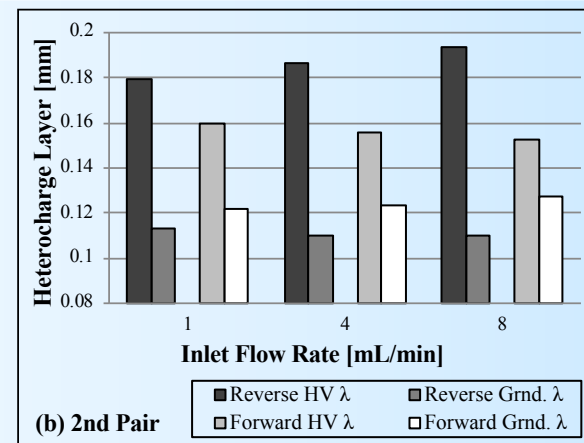
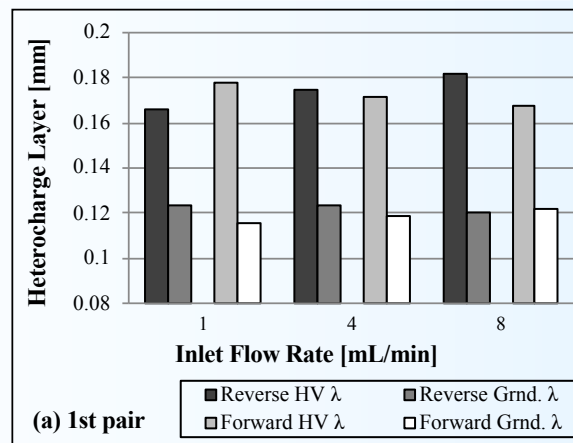
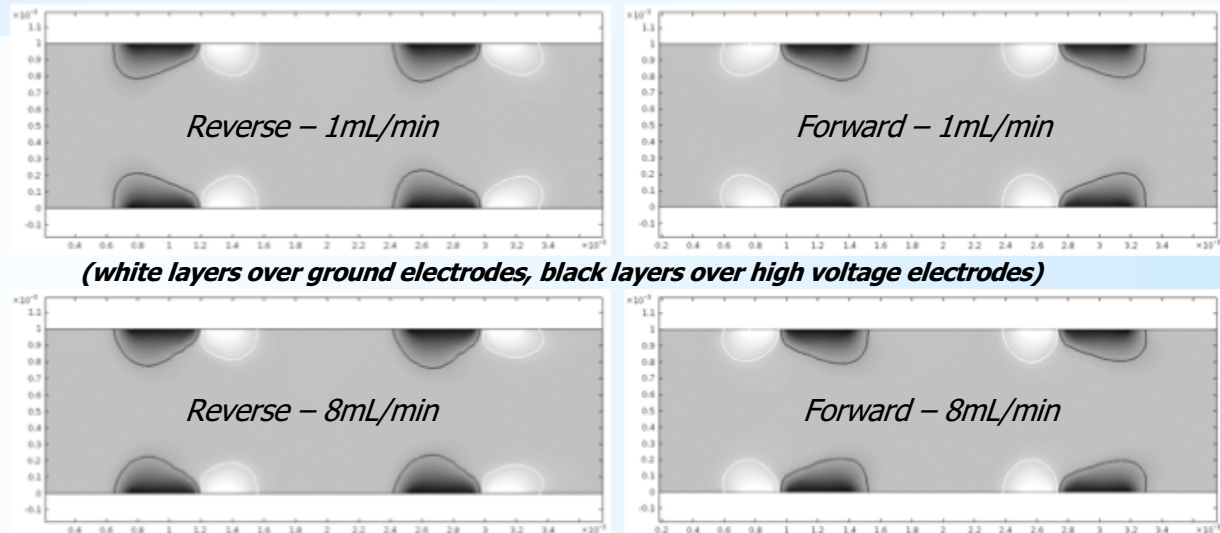



Experimental Work: PIV Flow Visualization of EHD Conduction

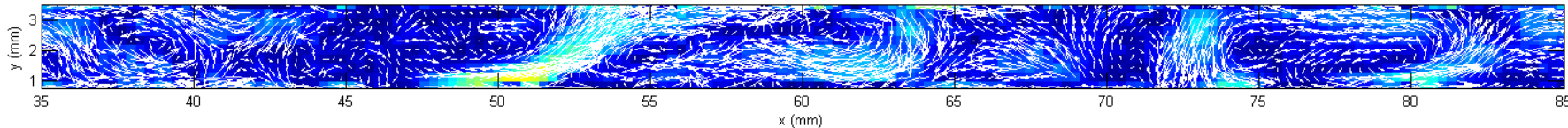

- Collaboration with the University of Poitiers, France
- Particle Imaging Velocimetry flow field measurements using unique PTFE particles
- Multiple pairs of EHD conduction electrodes, activated at 0-18kV
- Closed and open loop
- With and without externally applied flow via mechanical pump

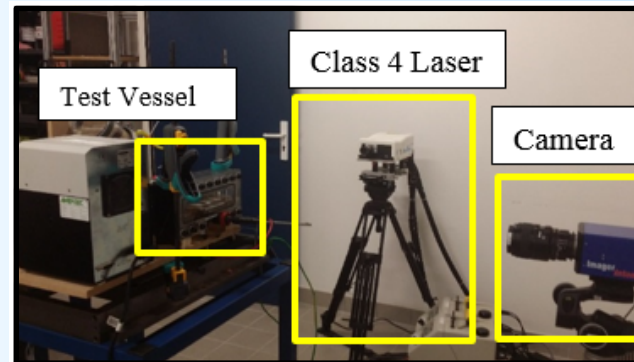
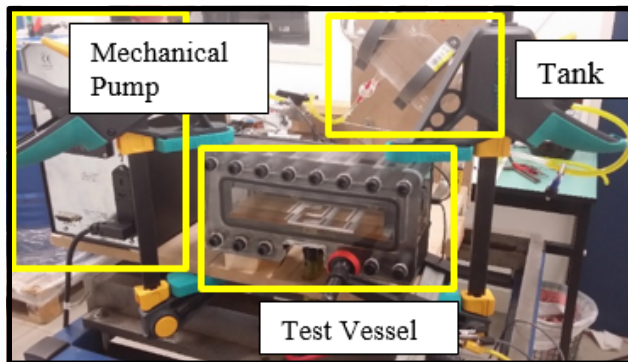
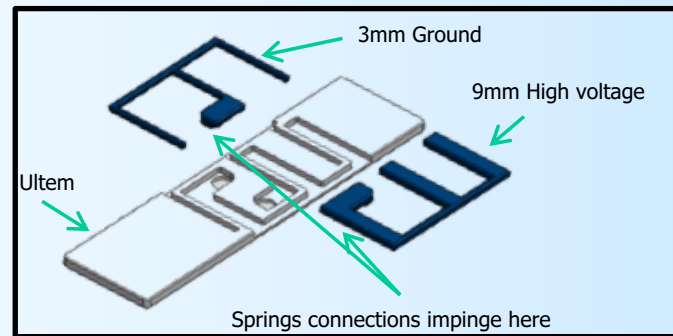



Oscillating Heat Pipe Project

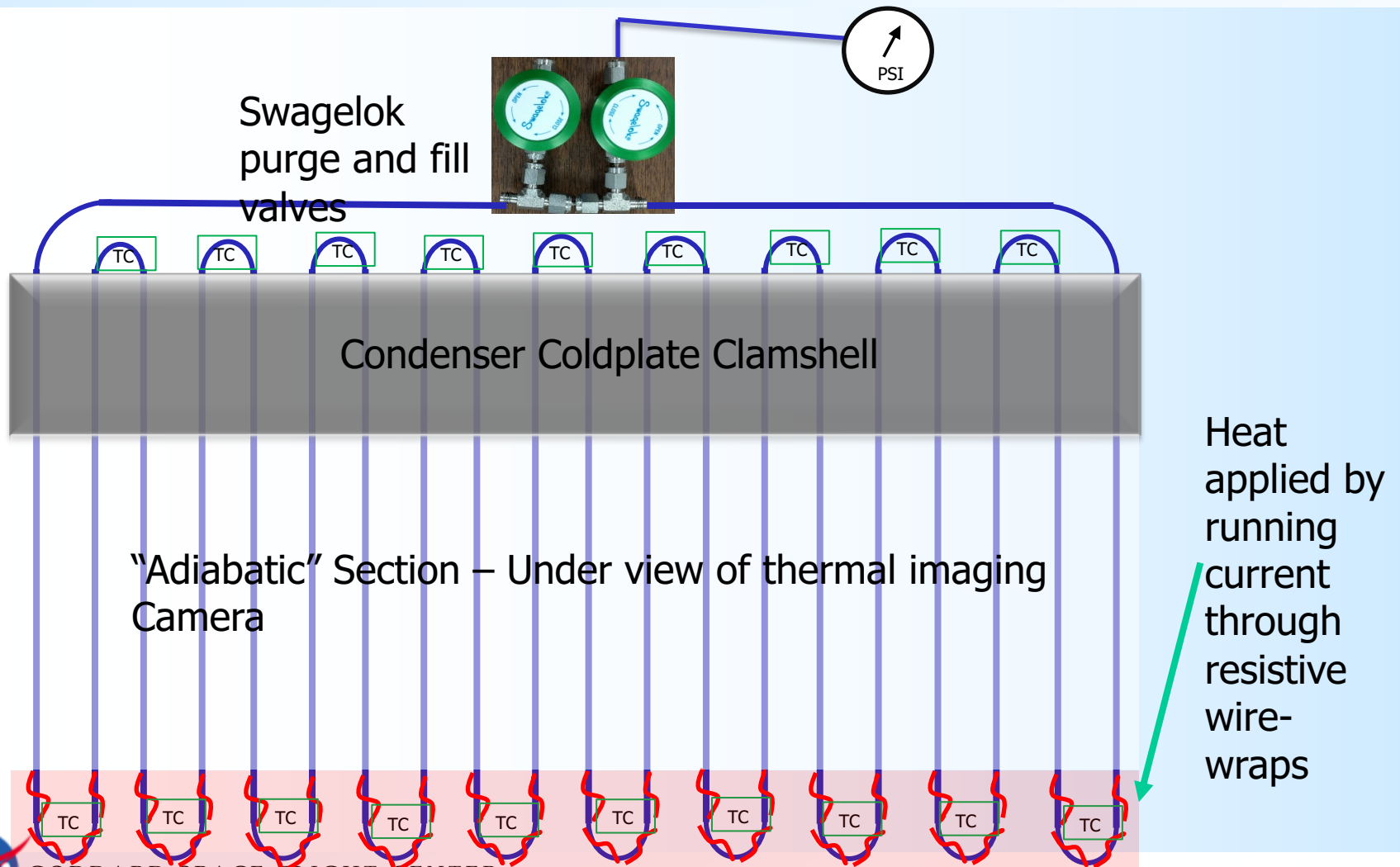



Experiment Set Up

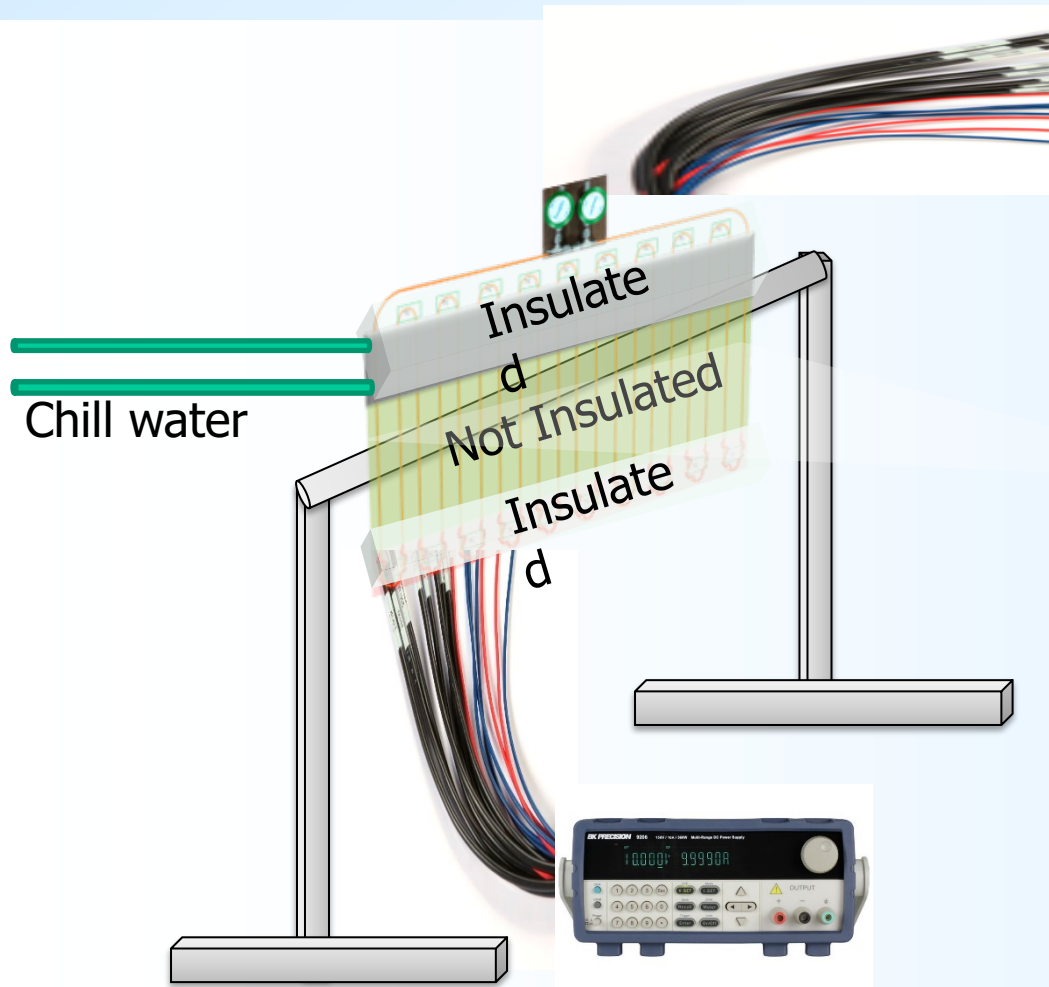

Data acquisition
for Thermocouples



Thermal
Imaging of
Adiabatic
Section





Investigation Goals

- **Analyze Adiabatic 'Springs'**
- **Analyze Forces in Turns**
- **Evaluate Differential Heating, i.e., non-uniform heating in evaporator section**

