

Dynamic Impact Testing and Model Development in Support of NASA's Advanced Composites Program

Matthew E. Melis¹, J. Michael Pereira², Robert Goldberg³
NASA Glenn Research Center, Cleveland, OH, 44135

and

Mostafa Rassaian⁴
Boeing Research & Technology, Tukwila, WA, 98108

This paper presents an overview of the High Energy Dynamic Impact element of NASA's Advanced Composites Project (ACP). The paper summarizes the work done for the ACP to advance our understanding of the behavior of composite materials during high energy impact events and to advance the ability of analytical tools to provide predictive simulations. The experimental program carried out at the NASA Glenn Research Center is summarized and a status on the current development state of an advanced computational composite impact model will be provided. Future work will be discussed as the effort transitions from fundamental analysis and testing to investigating sub-component structural concept response to impact events.

I. Introduction

The NASA Advanced Composites Program (ACP) was created with the goal of reducing the development and certification timeline for new composite structures used in aeronautics applications. One element of the program, entitled High Energy Dynamic Impact (HEDI), focuses on the development and validation of high-fidelity, physics based computational models to predict deformation, damage, and failure of composite materials undergoing high energy impact events. The technical approach of this effort was based on conducting a thorough assessment of selected dynamic impact tools to identify and address key deficiencies in the current state-of-the-art. The HEDI work is twofold: performed in part through in-house efforts at NASA Glenn (GRC), and in part through a collaborative team consisting of NASA, Boeing, Pratt & Whitney, and General Electric Aviation, called the Advanced Composites Consortium (ACC). The overall work has been organized to progress through a traditional incremental building block approach moving from fundamental coupon test and simulations to the more complex configured structure.

The in-house work at GRC is comprised of four primary subject areas: 1) Development of a new state of the art damage, deformation, and failure model, MAT213, to be integrated into the commercially available LS DYNA impact analysis code; 2) Impact testing on multiple composite materials/architectures (small scale 12" x 12" flat panel) for verification and validation of impact analysis tools; 3) Studies to quantify the effect of material processing variations on high energy impact resistance; and 4) Establishing a "virtual" testing framework for determining composite material parameters for analysis tools when actual tests are not practical. The flat panel testing conducted for the in-

¹ Aerospace Engineer, Structural Mechanics Branch, 21000 Brookpark Road, Cleveland, OH 44135, AIAA non-member

² Aerospace Engineer, Structural Dynamics Branch, 21000 Brookpark Road, Cleveland, OH 44135, AIAA non-member

³ Research Aerospace Engineer, Ceramic and Polymer Composites Branch, 21000 Brookpark Road, Cleveland, OH 44135, AIAA Associate Fellow.

⁴ Boeing Technical Fellow, Structures Technology, 9725 East Marginal Way South, Tukwila, WA 98108, AIAA Associate Fellow

house studies was done on three materials: T800/F3900 angle-ply laminate, T700/TC275-1 triaxially braided composite and T700/MTM45-1 triaxially braided composite.

The ACC work consisted of studies to evaluate the capability of current analysis tools benchmarked against data from an extensive number of large flat panel (25"x25") composite impact tests conducted on four separate material systems: resin infused T700/5208 triaxial braid, resin infused T800/AMD-825 triaxial braid, IM7/8552 tape and IM7/8552 plain weave fabric.

The purpose of this paper is to provide an executive overview of the HEDI effort for NASA's Advanced Composites Program and establish the foundation for the remaining papers to follow in the 2018 SciTech special session "NASA ACC High Energy Dynamic Impact". This paper summarizes the work done for the Advanced Composites Program to advance our understanding of the behavior of composite materials during high energy impact events and to advance the ability of analytical tools to provide predictive simulations. The experimental program carried out at GRC is summarized and a status on the current development state for MAT213 will be provided. Future work will be discussed as the HEDI effort transitions from fundamental analysis and testing to investigating sub-component structural concept response to impact events.

II. Ballistic Impact Testing

Impact testing for the HEDI effort was conducted at the NASA Glenn Ballistic Impact Lab. During the first phase of ACP, two sizes of composite flat panels tests were impacted in the normal direction with one of four selected projectile types: 12" x 12" panels clamped by a circular frame with an inner diameter of 10 inches (Figure 1) in accordance with ASTM D8101¹, and 25" x 25" panels clamped in a square frame (Figure 2). Seven materials were evaluated with varying architectures consisting of triaxial braid, plain weave, and tape layups. The intended goal of these tests was to establish a penetration threshold velocity and quantify the dynamic deformation and failure response for each panel type with its selected projectile. The penetration definition was met if the projectile completely passed through the test article with residual kinetic energy. The results of these tests were compiled for comparative purposes to the numerical tools being evaluated by the team.

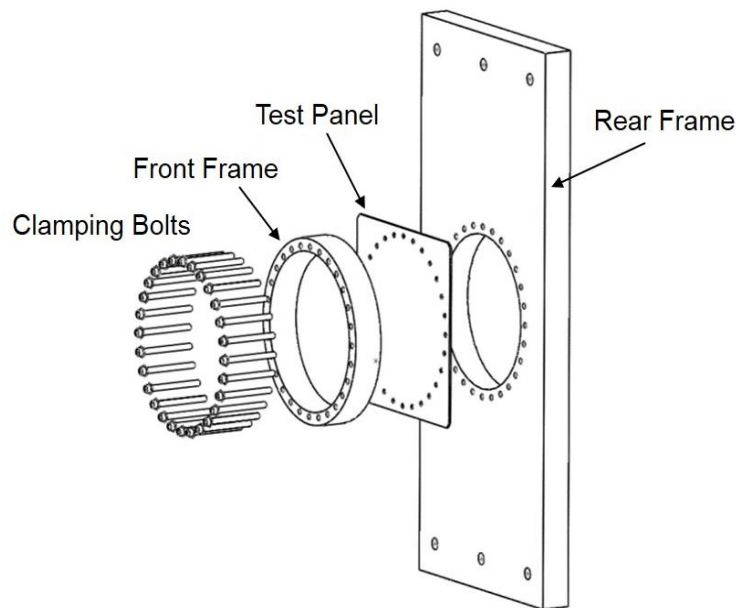

Figure 1. Test Fixture for 12" x 12" flat panels

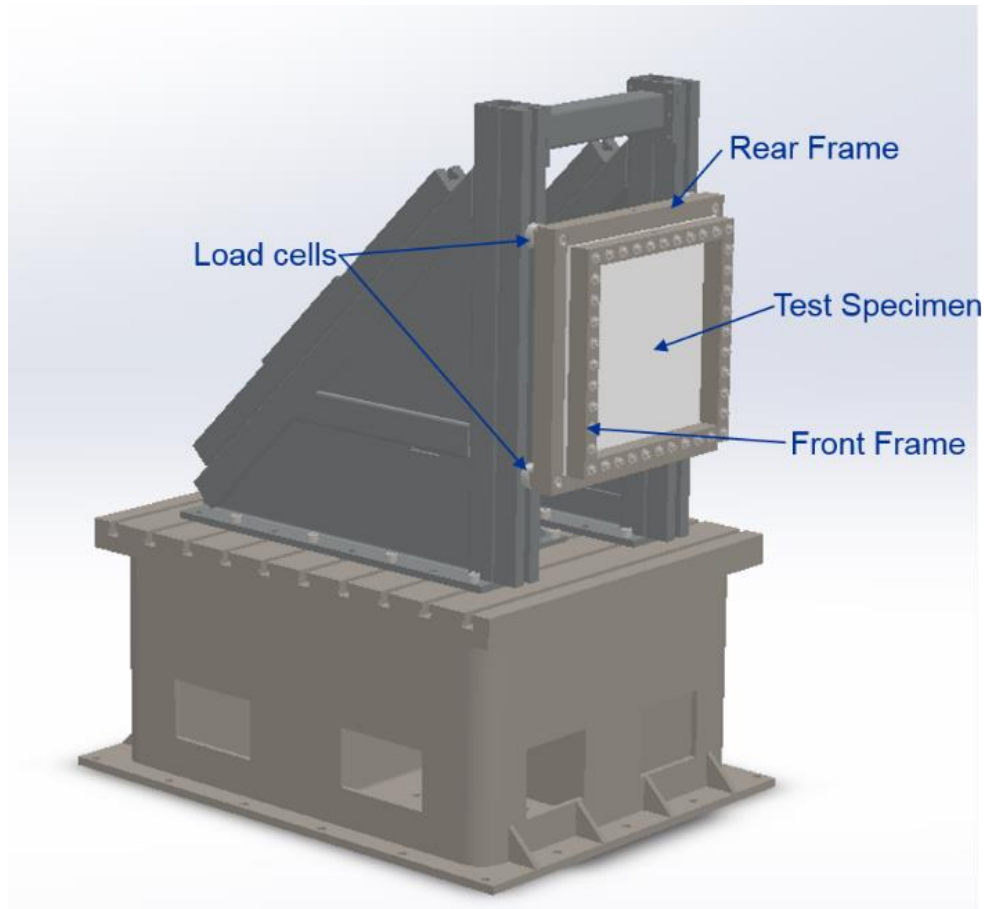

Figure 2. Test Fixture for 24" x 24" flat panels

The small panel impact tests were performed as per ASTM Standard D8101/D8101M (2017)¹. This test method measures the resistance of flat composite panels in a specific clamping configuration to penetration by a blunt projectile in free flight. The resistance to penetration is quantified by a statistical function that defines the probability of penetration for a given impact velocity or kinetic energy and allows the computation of a 50% probability of penetration. It is intended to screen and compare materials for impact performance and penetration resistance under the same test conditions. The test setup is such that a flat composite panel is fixed between a circular-shaped clamping fixture and a large base fixture (Figure 1), each with a large coaxial hole defining a region of the panel that is subjected to impact in the normal direction by a blunt projectile shown in Figure 3. Clamping pressure is provided by twenty-eight through bolts that pass through the front clamp, the test specimen and the back plate.

The large panel tests utilized three different projectiles specified by Pratt and Whitney, Boeing and General Electric Aviation. The projectile used for the Pratt and Whitney tests was a Ti-6Al-4V cylinder with a hemispherical nose (Figure 4a). The average mass of the projectile was approximately 1110 g.

The same two projectiles were used for the test panels manufactured by Boeing and General Electric Aviation. One was a right circular cylinder made from Flexane 94[®] with a length of 3.5 inches and a diameter of 3 inches (Figure 4b). This projectile is referred to as the blunt projectile. The second was a Ti6Al4Vn square block with dimensions of 2 inches by 2 inches by 0.25 inches and referred to as a sharp projectile. The titanium was embedded in a Flexane 94[®] cylinder and encased in a hard foam sabot (Figure 4c).

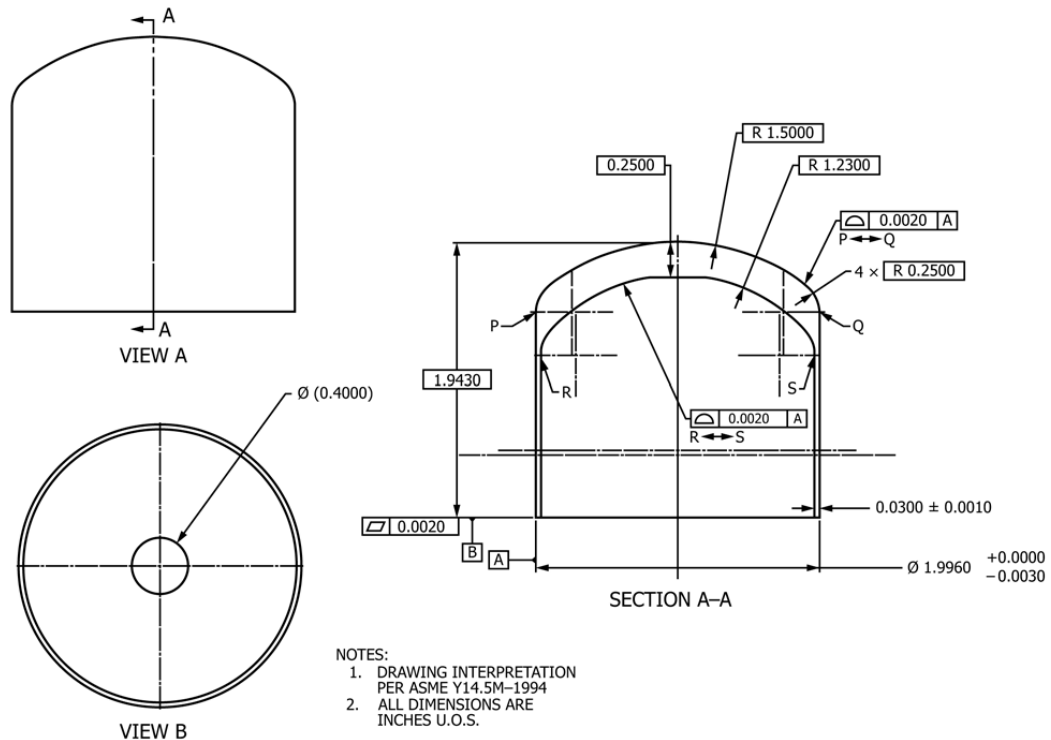

Figure 3. Projectile used for small panel impact testing. Material is AL2024. Projectile mass is 50 +/- 0.5 g. Dimensions in inches.

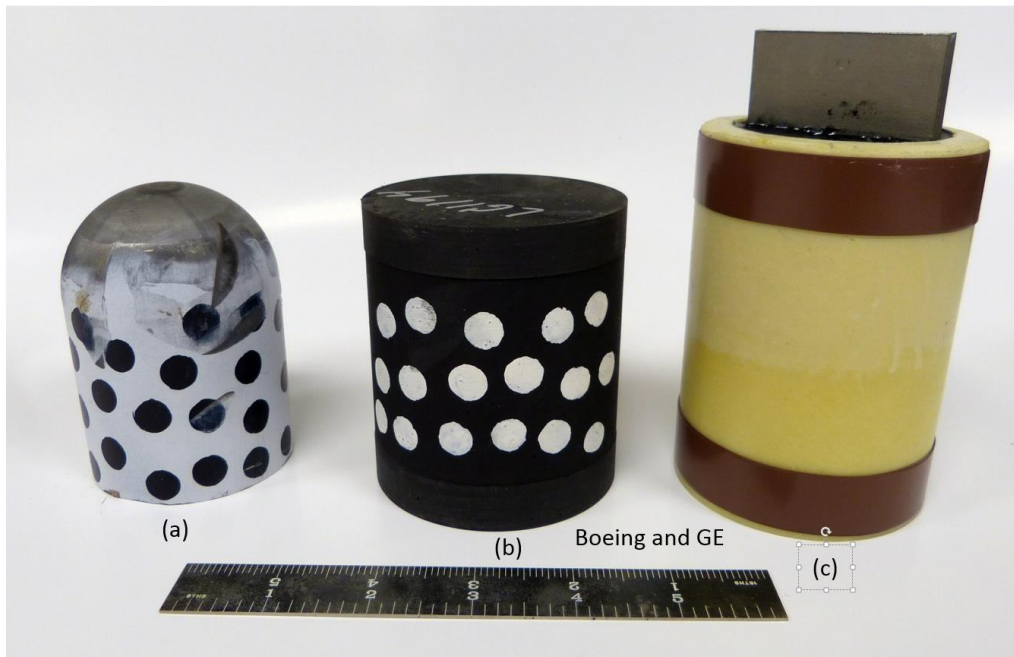

Figure 4. (a) Pratt and Whitney Projectile. (b) Blunt Projectile provided by Boeing and GEA; (c) Sharp Projectile provided by Boeing and GEA. Projectiles (a) and (b) after impact test showing markers for photogrammetric measurements

Single stage gas guns with varying barrel diameters were used to accelerate the projectiles into the composite test articles. Instrumentation consisted of high speed digital cameras used for both quantitative and qualitative data and load cells supporting the test fixture. The cameras were used to capture front, side, top, and rear views of the panels during the test to capture panel response and projectile velocities. Camera pairs were used to capture panel deformation, strain, and projectile kinetics from both the front and back of the test fixture using commercial photogrammetry software. Markers, to assist software tracking, are typically seen on the test articles and fixturing in the test imagery. Figure 5 shows a typical image sequence from a test of a blunt projectile impacting a 40 ply IM7/8552 tape layup panel at nearly 600 ft/sec.

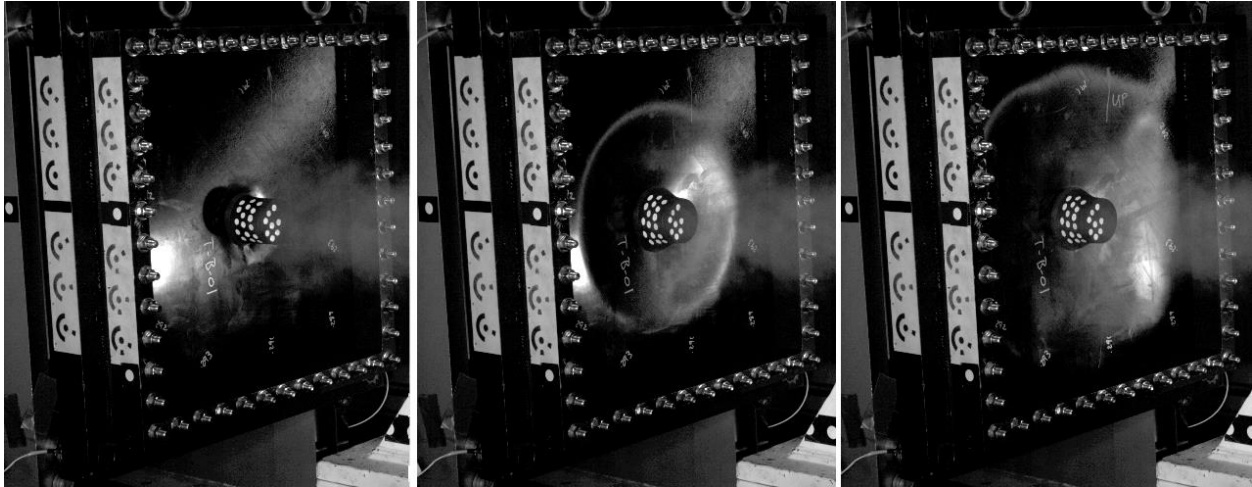

Figure 5. Front view of a blunt projectile impacting an composite panel 40ply Tape Layup at 586 ft/sec

Critical information taken from each test includes quantifying the kinetic energy of the projectile before and after the impact event. Target tracking on the high speed images with photogrammetry software enables the definition of a spatial coordinate system in which velocity and orientation of the projectile can be calculated at each frame. Figure 6 depicts an example of the photogrammetry software interface mapping projectile pitch, yaw, and velocity of the projectile throughout the impact event on a large composite panel.

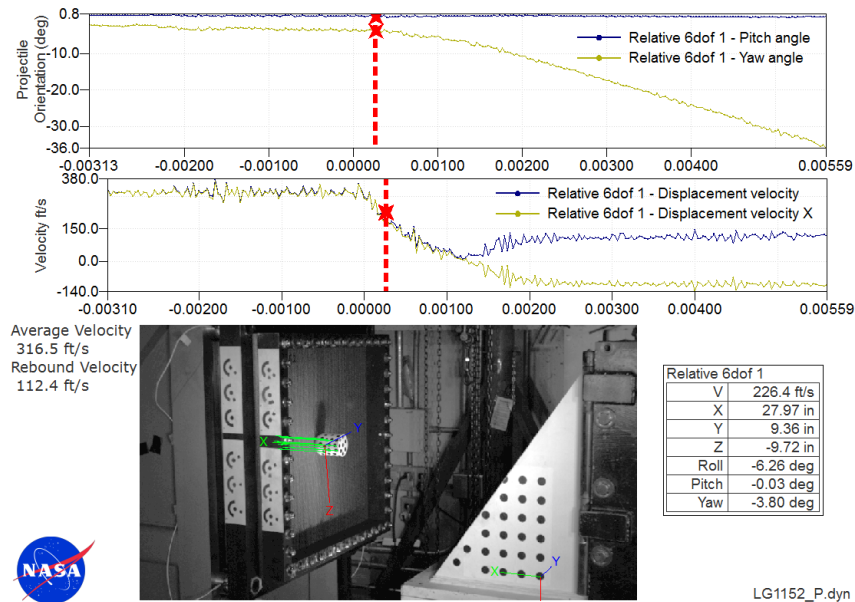

Figure 6. Photogrammetry software enables the calculation of spatial coordinate systems and determination of projectile velocity vectors within those systems for kinetic energy determination

Displacements and strains on the rear surface of the panels were computed using commercial digital image correlation (DIC) software (ARAMIS, GOM GmbH, Braunschweig, Germany) in conjunction with a calibrated pair of high speed cameras focused on the regions of interest in the test set up. For most tests, only backside panel deformations were captured as seen in Figure 7, however, for a subset of small panel tests, both front and backside deformation measurements were made and results merged to provide a more complete capture of the total panel deformation. Figure 8 provides an example of a merged data set demonstrating simultaneous deformation of a composite panel undergoing impact.

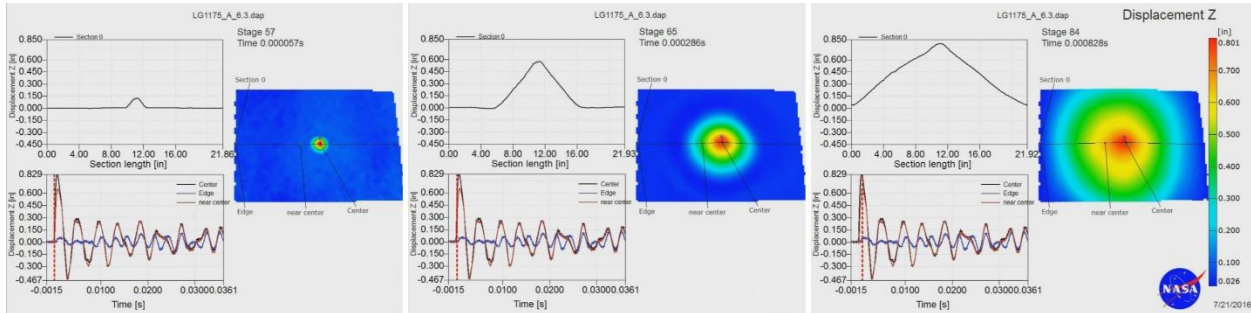

Figure 7. Photogrammetry software calculates full-field 3-D deformation of the back side of a composite panel as it undergoes an impact event.

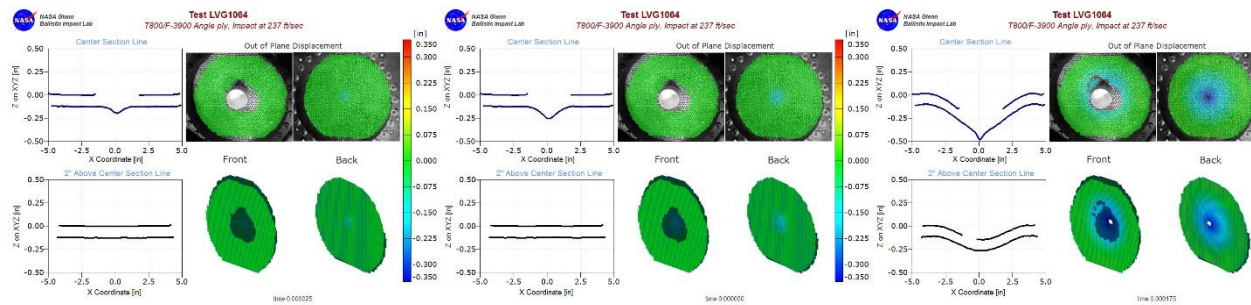

Figure 8. Photogrammetry software calculates full 3-D deformations of both front and back sides of composite panel as it undergoes impact event.

As part of the small panel impact testing local temperature rises due to adiabatic heating that have been found to occur in composite panels subjected to ballistic impact conditions have been investigated². This investigation has been made possible due to the recent availability of high speed infrared cameras capable of detecting local temperature rises throughout an impact event. Preliminary tests have identified that the local temperatures in the polymer matrix constituent can rise above the glass transition temperature, which can have a significant influence on the material impact performance. Additionally, it has been observed that the character of the local temperature rises during impact are significantly different depending on if brittle or ductile matrix materials are utilized. Figure 9 shows thermal high speed imagery for triaxially braided composites constructed using toughened (PR520-Figure 9 top) or untoughened (3502-Figure 9 bottom) matrices. Figure 9 also shows a plot where the maximum material temperature is plotted as a function of projectile velocity. As can be seen in Figure 9, for the composite constructed using the toughened resin, the region of the temperature rise is localized to the impact zone and the magnitude of the local temperature is relatively high, even for relatively low impact velocities. For the composite constructed with the brittle resin, on the other hand, the temperature rise has a much lower magnitude and takes place over a much more diffuse region of the material. While not shown here, another feature of the panels constructed using the brittle matrix that have been impacted is that significant local matrix failures were observed over the diffuse region that also experienced the temperature rises. Future efforts will involve examining these mechanisms in much more detail and developing improved analytical tools which will incorporate these local effects.

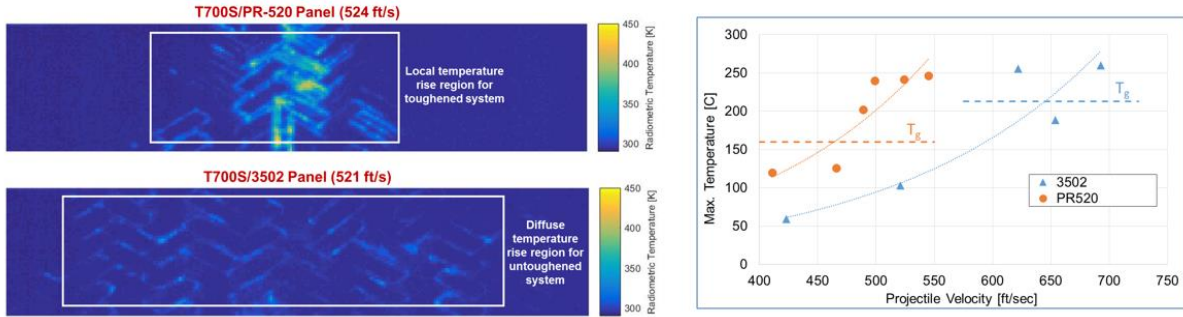

Figure 9. Frames from a high speed infra-red camera show different thermal response for composites with toughened (PR520) and untoughened (3502) resin. At higher impact velocities temperatures significantly higher than the glass transition temperature are recorded.

All of the data from the impact testing will ultimately be archived and used to validate the predictive fidelity of MAT213 and the other candidate material models being employed under HEDI. The archived data included a test description with all test parameters, photos of the specimen and projectile before and after the test, tabular and graphical load cell data, photogrammetric displacement, velocity, and orientation measurements.

III. MAT213 Model Development

The need for accurate material models to simulate the deformation, damage and failure of polymer matrix composites under impact conditions is becoming more critical as these materials are gaining increased usage in aerospace applications. While there are a variety of composite material models available for use in commercial transient dynamic finite element codes such as LS-DYNA, several key deficiencies have been identified by the aerospace community limiting the potential fidelity of such methods³. Some of the specific desired features that have been identified include the incorporation of both plasticity and damage within the material model, as well as the ability to utilize experimentally based tabulated input to define the evolution of plasticity, damage and failure as opposed to specifying discrete input parameters (such as modulus and strength) and employing analytical functions based on curve fitting. Furthermore, a need has been expressed that the failure model should also incorporate experimentally based on tabulated input, and have the capability to either be stress or strain based. To address these needs, NASA has devoted significant resources to the development of a new material model to be implemented into LS-DYNA and made commercially available in the public domain.

MAT213^{3,4,5,6} is assembled from three distinct and sophisticated sub-models: deformation, damage, and failure. The deformation model, meant to simulate the nonlinear material response observed during the loading of a composite, is based on extending the commonly used Tsai-Wu composite failure model into a strain-hardening based orthotropic plasticity model with a non-associative flow rule². The evolution of the yield surface is determined based on tabulated stress-strain curves in the various normal and shear directions and is tracked using the effective plastic strain. The deformation model also allows for the incorporation of temperature and strain rate effects. Temperature and rate effects are accounted for by utilizing a series of tabulated stress-strain curves, with each curve representing the material response in a particular coordinate direction at a particular strain rate and temperature³.

The damage model portion of the material model is designed to capture the nonlinear unloading and post-peak strain softening observed in composites. To compute the evolution of damage, a strain equivalent formulation is used, which allows the plasticity and damage calculations to be uncoupled, with the plasticity calculations taking place in effective (undamaged) stress space. A tensorial damage variable is employed to account for the variation in the evolution of damage in the various coordinate directions. A diagonal damage tensor is assumed to maintain a one-to-one relationship between the true and effective stresses in the various coordinate directions. However, in composites, particularly composites with complex fiber architectures, experimental evidence has shown that a load in a particular coordinate direction may result in a loss in stiffness in other normal and shear coordinate directions. To account for

this phenomena while still maintaining a diagonal damage tensor, a semi-coupled approach is employed where the overall damage in a particular coordinate direction is assumed to be a multiplicative combination of the damage in that direction resulting from the applied loads in the various coordinate directions³.

For the failure model, a tabulated approach is utilized in which a stress or strain based invariant is defined as a function of the location of the current stress state in stress space to define the initiation of failure⁴. In this manner, unlike in traditional failure models where the mathematical functions used to define the failure surface impose a specific shape on the failure surface, arbitrarily shaped failure surfaces can be defined. An example of this process is shown in Figure 10 and Figure 11. In Figure 10, an example two-dimensional failure surface for a representative polymer matrix composite is shown. The failure surface is converted into a form amenable for tabulated input by defining the location and magnitude of the points on the failure surface by using a cylindrical type of coordinate system (r and θ in Figure 10). In Figure 11, the failure surface shown in Figure 10 is replotted in terms of the variables r and θ . By redefining the failure surface in this manner, the failure surface can be defined as a single-valued function which leads itself to being input into the material model in a tabulated fashion.

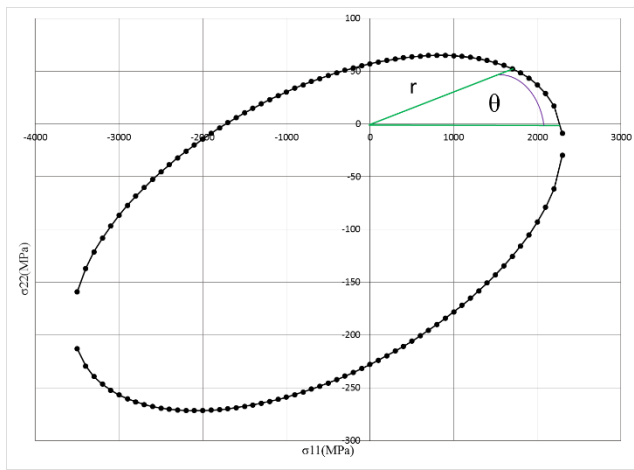

Figure 10. Tsai-Wu failure surface for AS4/3501-6 composite.

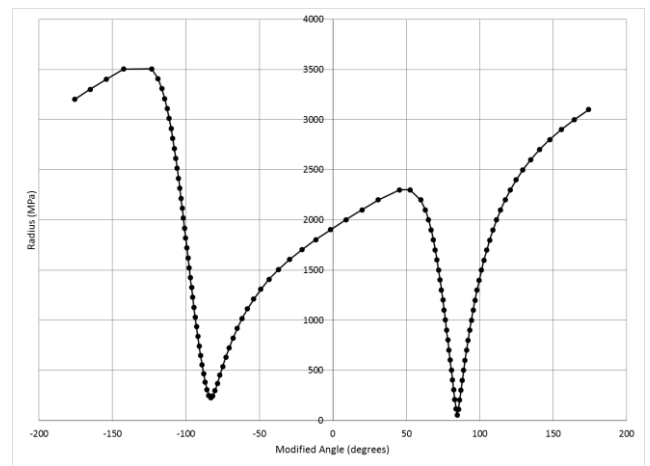

Figure 11. Plot of failure surface for AS4/3501-6 composite utilizing cylindrical coordinate system.

Currently, a version of MAT213 with an uncoupled version of the damage model and a simplified max strain-to-failure mode has been implemented in LS-DYNA and is undergoing beta testing and validation studies. Initial simulations with impacts on a unidirectional T800/F3900 composite panel have shown favorable agreement with photogrammetry displacement measurements taken from small panel impact tests at NASA Glenn⁵. Figure 12 depicts this early validation comparison.

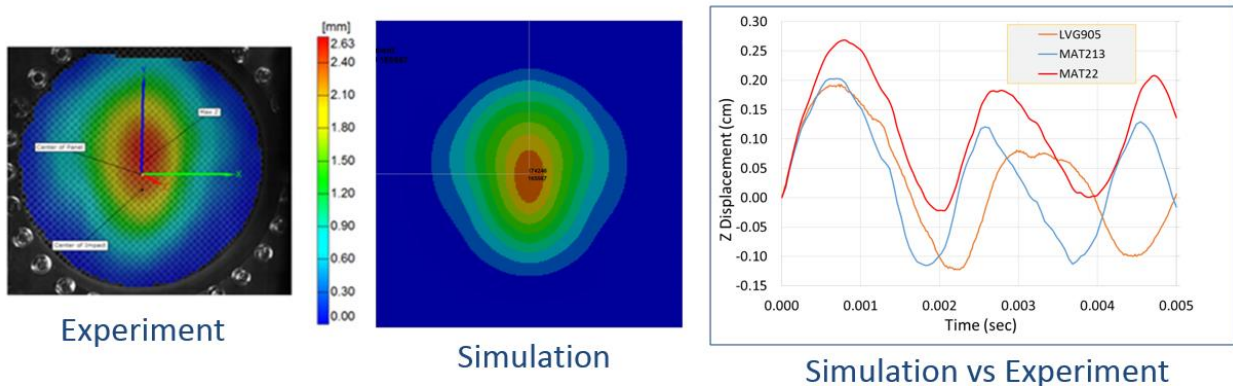

Figure 12. Comparison of out-of plane displacement experimental photogrammetry data with MAT213 simulation of impact on T300/F3900 composite panel.

IV. Summary

Testing and model development goals have been successfully met to date under the HEDI effort with over 150 impact tests on three materials in the in-house studies and four materials in the ACC activities. A commercially available beta version of the MAT213 model has been implemented in LS-DYNA. The impact test data has been archived and distributed to the ACC team members and will be used both for material modeling evaluation and for evaluation and validation of existing and new composite impact models. Forward work will focus on the implementing the failure model into LS-DYNA, continuing validation of MAT213 against the flat panel test data, and conducting subcomponent impact tests for second level validation of MAT213.

V. References

- ¹ASTM D8101/D8101M, “Standard Test Method for Measuring the Penetration Resistance of Composite Materials to Impact by a Blunt Projectile”, ASTM International, West Conshohocken, PA, 2017, DOI: 10.1520/D8101_D8101M-17
- ²Johnston, J.P., Pereira, J.M., Ruggeri, C.R. , and Roberts, G.D., “High Speed Thermal Imaging on Ballistic Impact of Triaxially Braided Composites,” *Proceedings of the American Society for Composites (ASC) 32nd Technical Conference*, West Lafayette, IN, Oct. 23-25, 2017.
- ³Goldberg, R.K.; Carney, K.S.; DuBois, P.; Hoffarth, C.; Harrington, J; Rajan, S.; and Blankenhorn, G.: “Development of an Orthotropic Elasto-Plastic Generalized Composite Material Model Suitable for Impact Problems”, *Journal of Aerospace Engineering*, Vol. 29, no. 4, 04015083, 2016.
- ⁴Goldberg, R.K.; Carney, K.; DuBois, P.; Hoffarth, C.; Rajan, S.; and Blankenhorn, G.: “Incorporation of Plasticity and Damage Into an Orthotropic Three-Dimensional Model With Tabulated Input Suitable for Use in Composite Impact Problems”, NASA TM-2015-218849, 2015.
- ⁵Goldberg, R.K.; Carney, K.S.; DuBois, P.; Hoffarth, C.; Khaled, B.; Shyamsunder, L.; Rajan, S.; and Blankenhorn, G.: “Incorporation of Failure Into an Orthotropic Three-Dimensional Model With Tabulated Input Suitable for Use in Composite Impact Problems”, NASA TM-2017-219442, 2017.
- ⁶Hoffarth, C.; Khaled, B.; Shyamsunder, L.; Rajan, S.; Goldberg, R.K.; Carney, K.S.; DuBois, P.; and Blankenhorn, G: “Verification and Validation of a Three-Dimensional Orthotropic Plasticity Constitutive Model Using a Unidirectional Composite”, *Fibers*, Vol. 5, Issue 1, Number 12, 2017.