

## Variation in gene copy number and polymorphism of the human salivary amylase isoenzyme system in Caucasians

Ruud A. Bank<sup>1</sup>, Ewald H. Hettema<sup>1</sup>, Marian A. Muijs<sup>1</sup>, Gerard Pals<sup>1</sup>, Fré Arwert<sup>1</sup>, Dorret I. Boomsma<sup>2</sup>, and Jan C. Pronk<sup>1</sup>

<sup>1</sup>Institute of Human Genetics, Medical Faculty, Vrije Universiteit, P.O. Box 7161, NL-1007 MC Amsterdam, The Netherlands

<sup>2</sup>Department of Psychonomics, Vrije Universiteit, De Boelelaan 1111, NL-1081 HV Amsterdam, The Netherlands

Received May 20, 1991 / Revised August 29, 1991

**Summary.** The polymorphic patterns of human salivary amylase of a large number of individuals of Caucasian origin were determined by using isoelectric focusing and polyacrylamide gel electrophoresis. Nine different salivary amylase protein variants were found; three of them are recorded for the first time and their heredity is shown. Some of the variants are encoded by haplotypes expressing three allozymes. Most variants display low frequencies. Analysis of the relative intensities of variant-specific isozyme bands, combined with segregation analysis, show that extensive quantitative variation is present in the population. The numbers of salivary amylase genes in some families showing quantitative variation at the protein level have been estimated by the polymerase chain reaction. We present evidence that quantitative variations in amylase protein patterns do not always reflect variations in gene copy number but that other mechanisms are also involved.

### Introduction

Human salivary  $\alpha$ -amylase (1,4  $\alpha$ -glucanohydrolase; EC 3.2.1.1) is a monomeric endoenzyme that hydrolyzes  $\alpha$ -1,4 glycosidic bonds of glucose polymers. It consists of a polypeptide chain of 496 residues (Nishide et al. 1986; Sato et al. 1986) with a calculated molecular weight of 55933 Da. About a quarter of the human  $\alpha$ -amylase secreted into saliva is glycosylated (Bank et al. 1991).

In man, amylase is produced by two different loci, AMY1 (salivary amylase) and AMY2 (pancreatic amylase), which show strong tissue-specific expression. Both loci are separated by only 30 kb on the short arm of chromosome 1 (p21) (Zabel et al. 1983; Gumucio et al. 1988; Groot et al. 1989).

Isozymes of AMY1 were first reported by Muus and Vnenchak (1964) using crystalline amylase prepared from pooled samples of whole saliva. The source of saliva (whole saliva, parotid, submandibular or sublingual

secretion) does not affect the electrophoretic expression of the isozymes (Ogita 1966; Wolf and Taylor 1967; Kauffman et al. 1973). The observed complex isozyme pattern can be explained as the result of two posttranslational modifications (glycosylation and deamidation) and one postsecretory modification (deglycosylation) of a single gene product (Merritt and Karn 1977; Bank et al. 1991).

Inherited variations in salivary amylase, shown by separation during electrophoresis on agar, agarose or polyacrylamide gels, have been reported by various authors (e.g., Merritt and Karn 1977). However, the frequencies of the individual variants described have been low. With the introduction of isoelectric focusing (IEF), genetic polymorphisms, mostly with a higher frequency, have been reported by Skude (1972), Pronk (1977), Pronk and Frants (1979), Pronk et al. (1979; 1982; 1984), de Soyza (1978; 1982), Kühnl and Tischberger (1980), Eckersall et al. (1981), Eckersall and Beeley (1981), Tsuchida and Ikemoto (1987), and Boan and Caeiro (1988).

Based on the observation that some individuals express three different salivary amylase gene products (phenotype AMY1 1,2,3), Pronk et al. (1982) postulated a duplication of the salivary amylase gene. The genomic structure of the AMY\*1,2 and AMY\*1,3 haplotypes from a woman with phenotype AMY1 1,2,3 was elucidated by Groot et al. (1989). This analysis showed that the chromosome encoding AMY1 3 carried a haplotype (designated AMY\*HO) consisting of two pancreatic amylase genes and one salivary amylase gene. The other chromosome, encoding AMY\*1,2, carried a haplotype (designated AMY\*H2) consisting of the same two pancreatic amylase genes, two amylase pseudogenes and five salivary amylase genes. With the use of recombinant DNA techniques, haplotypes with one, three, five and seven salivary amylase genes (designated AMY\*HO, AMY\*H1, AMY\*H2 and AMY\*H3, respectively) were shown to be present in the population (Groot et al. 1989). This implies that the number of salivary amylase genes present in a diploid genome can vary from two to at least fourteen, depending on the combination of hap-

**Table 1.** Nomenclature of human salivary alpha amylase proteins, genes and haplotypes

Salivary allozymes <sup>a</sup>	AMY1 1; AMY 1 2; AMY1 3; AMY1 5; AMY1 6; AMY1 7; AMY1 9; AMY1 10; AMY1 11	
Phenotypes <sup>b</sup>	AMY1 1	Expressing AMY1 1
	AMY1 3	Expressing AMY1 3
	AMY1 1,2	Expressing AMY1 1 and AMY1 2
	AMY1 1QL,2	Expressing AMY1 1 (quantitatively low) and AMY1 2
	AMY1 1QE,2	Expressing AMY1 1 (quantitatively elevated) and AMY1 2
Haplotypes (protein) <sup>c</sup>	AMY1 1,2,3	Expressing AMY1 1, AMY1 2 and AMY1 3
	AMY1*1	Expressing AMY1 1
	AMY1*1,2	Expressing AMY1 1 and AMY1 2
Haplotypes (DNA) <sup>c,d</sup>	AMY1*3	Expressing AMY1 3
	AMY*H0	Haplotype with one salivary amylase gene
	AMY*H1	Haplotype with three salivary amylase genes
Genotypes (protein) <sup>e</sup>	AMY*H2	Haplotype with five salivary amylase genes
	AMY*H3	Haplotype with seven salivary amylase genes
	AMY1*1/*1	Genome with haplotypes AMY1*1 and AMY1*1
Genotypes (DNA) <sup>e</sup>	AMY1*1,2/*3	Genome with haplotypes AMY1*1,2 and AMY1*3
	AMY*H0/*H0	Genome with haplotypes AMY*H0 and AMY*H0 (two salivary genes)
	AMY*H0/*H1	Genome with haplotypes AMY*H0 and AMY*H1 (four salivary genes)
	AMY*H2/*H2	Genome with haplotypes AMY*H2 and AMY*H2 (ten salivary genes)

<sup>a</sup> The term allozyme is used to designate a set of genetically determined isozymes, i.e., the combined set of isozymes that are the product of a single gene. The nomenclature used in this Table is in agreement with the guidelines for human gene nomenclature (Shows et al. 1987)

<sup>b</sup> Only the most common phenotypes are listed. For a complete list see Fig. 5

<sup>c</sup> The haplotype-designations were introduced by Groot et al. (1989). The haplotypes behave as alleles and therefore the nomenclature proposed by the Human Gene Mapping Committee (Shows et al. 1987) is used to indicate alleles. Throughout this paper, we avoid using the term allele, but instead use the terms haplo-

type and variant (or allozyme). A haplotype unequivocally indicates a number of linked genes and thus all the proteins expressed by the genes organized in that haplotype. A distinction is made between haplotypes at the DNA level and at the protein level (see also Discussion). The term allozyme is used to designate the set of isozymes that are the product of a single gene

<sup>d</sup> The detailed structure of the haplotypes AMY\*H0, AMY\*H1, AMY\*H2 and AMY\*H3 is described in Groot et al. (1989). Only the number of salivary amylase genes present on these haplotypes is indicated here

<sup>e</sup> Only a few examples of possible combinations of haplotypes are shown

lotypes present. Because of this interindividual variation in the number of genes, extensive variation in salivary amylase expression in the population is expected.

In this paper, we present data showing that the variation present at the DNA level, reflected at the protein level, has previously been unknown because of its mainly quantitative nature. To be able to draw this conclusion, we have determined the polymorphic salivary amylase patterns of a large number of individuals, all of Caucasian origin, using IEF and nondenaturing polyacrylamide gel electrophoresis (PAGE). We review the available IEF data of salivary amylase polymorphisms in Caucasians and report three new variants. In addition, the gene copy number of salivary amylase genes was estimated in some individuals expressing quantitative variation at the protein level. We present evidence that quantitative variations in amylase protein patterns do not always reflect variations in gene copy number but that other mechanisms are also involved. The nomenclature used throughout this paper is summarized in Table 1.

## Materials and methods

### Sample preparation

Whole saliva samples were collected from randomly selected healthy volunteers and were obtained without chemical stimulation.

The samples were centrifuged (5 min) in an Eppendorf centrifuge; the supernatants were collected and were either typed immediately or stored at  $-20^{\circ}\text{C}$ . Subsequently, samples were also collected from the families of individuals exhibiting variant phenotypes. Parotid saliva, stimulated with sour lemon, was obtained by means of a special device described by Curby (1953) from individuals expressing rare allozymes, and prepared as described above.

### Protein electrophoresis and staining methods

IEF was carried out in 0.2 mm flat bed polyacrylamide gels (250  $\times$  115 mm) using the LKB Multiphor apparatus with an LKB 2103 or 2197 power supply. The gels consisted of 1.4 ml acrylamide/*N,N'*-methylenebisacrylamide solution ( $T = 25.7\%$ ,  $C = 2.6\%$ ), 270  $\mu\text{l}$  Pharmalyte pH 4–6.5, 200  $\mu\text{l}$  Pharmalyte pH 5–8 and 3.55 ml Milli-Q water. After de-aeration, photopolymerization was performed for 3 h after addition of 0.85 ml riboflavin (4 mg/100 ml), 100  $\mu\text{l}$  ammonium peroxodisulfate (1 g/100 ml) and 2  $\mu\text{l}$  *N,N,N',N'*-tetramethylethylenediamine. Salivary samples (2  $\mu\text{l}$  diluted 2–4 times) were applied directly on the gel surface at a distance of 1.5 cm from the anodal end of the gel. The electrode solutions were 0.04 M glutamic acid (anode) and 0.25 M NaOH (cathode). IEF was carried out at a power maximum of 10 W, and a voltage (maximum) of 1000 V for 4 h. No pre-focusing was performed. All experiments were conducted at  $4^{\circ}\text{C}$ . The pH of the gel was measured with an Ingoldt surface electrode. Typing of samples was always carried out independently by at least two investigators. On each gel, three samples with known phenotypes were run as a control and reference (AMY1 1, AMY1 1,2 and AMY1 1,2,3).

The saliva of interesting IEF phenotypes was also subjected to PAGE. PAGE and visualization of  $\alpha$ -amylase in IEF and PAGE gels was performed according to Bank et al. (1991).

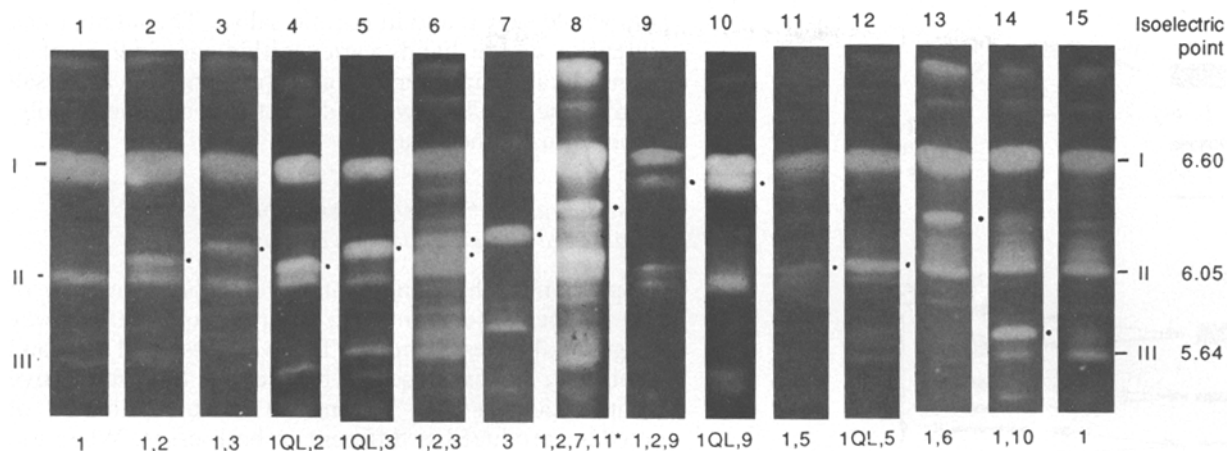

**Fig. 1.** Isoelectric focusing patterns of some human salivary amylase phenotypes. The phenotypes are indicated *below* each lane, but without the prefix AMY1 (1,2,3, instead of AMY1 1,2,3). The primary, secondary and tertiary bands of AMY1 1, the most common allozyme in the Caucasian population, are indicated at the *left* and at the *right*, numbered I, II and III. The primary products of the variant allozymes are indicated by a *black dot* at the *right* of each lane (for a schematic representation of allozymes and phenotypes see Figs. 4, 5). AMY1 1 is shown twice in *lanes 1 and 15* as a reference. In the phenotype marked by an *asterisk* in *lane 8* (AMY1, 1,2,7,11), only allozymes AMY1 1, AMY1 2 and AMY1 7 can be recognized, because AMY1 11 can only be distinguished using PAGE (see Fig. 2, lane 8, and Fig. 4). Note that, in the phenotypes AMY1 1,2,3 (*lane 6*) and AMY1 1,2,7,11 (*lane 8*), the primary gene product of AMY1 2 is more intense than that of AMY1 3 and AMY1 7

#### Polymerase chain reaction amplification of AMY1 and AMY2

Polymerase chain reaction (PCR) amplifications of the intron 5 region of the AMY 1 and AMY 2 genes were performed employing a Bioexcellence thermal cycler with Bethesda Research Laboratories *Taq* DNA polymerase. The sequence of the primers used was CCAGTTTCCTTCTTAGCT (-490/-472, nucleotide numbering according to Groot et al. 1988) and ATCAACCCATCGCCATTTC (+97/+114). The reaction mixture (20  $\mu$ l) contained 40 ng genomic DNA, 20 pMol each primer, 420 pMol each of dGTP, dATP, dCTP, and dTTP, 0.165 pMol  $^{32}$ P  $\alpha$ -dATP (= 0.5  $\mu$ Ci), 10 mM TRIS/HCl pH 8.3, 2 mM MgCl<sub>2</sub>, 50 mM KCl, 10% DMSO and 0.2 mg/ml bovine serum albumin, with 0.8 units *Taq* DNA polymerase. Twenty cycles of amplification were carried out overlaid with 25  $\mu$ l paraffin oil. Each cycle consisted of 1 min denaturation at 95°C, 2 min annealing at 47°C, and 3 min extension at 72°C. The PCR results in an AMY-1-specific product of 604 bp and an AMY-2-specific product of 582 bp.

#### Electrophoresis and quantitation of PCR-amplified DNA

One-fifth of the product from each amplification reaction was analyzed by PAGE in TBE buffer pH 8.3 (0.09 M TRIS, 0.09 M boric acid, 2.5 mM EDTA). Gels consisted of 3.8% acrylamide/0.2% N,N'-methylenebisacrylamide/8 M urea in TBE buffer, and were run overnight at 600 V. After fixation for 15 min in 10% (v/v) acetic acid and drying (45 min at 80°C), the gels were exposed to X-ray film for 4 days. The resulting autoradiograms were analyzed quantitatively with the LKB 2202 Ultrascan laser densitometer. The area under the curve of each band was calculated with the LKB 2190-001 gelscan program and expressed as a percentage of the total area under the curve.

## Results and discussion

### Interpretation of the zymograms

The salivary amylase pattern of 314 unrelated individuals of Dutch and 55 of Spanish origin (surroundings of Sevilla) was determined by using IEF. Whole saliva or parotid saliva was used as the source of salivary amylase. As the amylase in whole saliva is of mixed origin, we tested whether the source of the amylase affects the isozyme patterns by comparing zymograms from whole saliva with zymograms from secretions of the parotid gland. None of the phenotypes reported here were dependent upon the source of saliva; therefore, we conclude that these phenotypes are unlikely to be artifacts arising from modifications that occur after secretion in the oral cavity.

Some of the phenotypes found with IEF and PAGE are shown in Figs. 1, 2. The complicated patterns show variation in the number, the position (qualitative variation) and the relative intensities (quantitative variation) of the isozyme bands. At present, these qualitative differences are reasonably well understood because of bio-

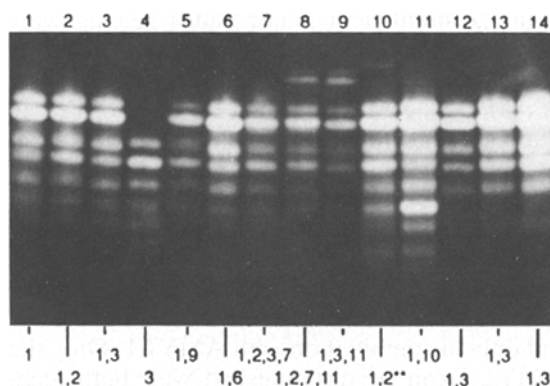

**Fig. 2.** PAGE patterns of some human salivary amylase phenotypes. The phenotypes shown are indicated *below* each lane, but without the prefix AMY1 (1,2,3, instead of AMY1 1,2,3). AMY1 7 (*lanes 7, 8*) can be seen as a faint band just below band two (from the *top*); this band is clearly visible in Fig. 8. \*\* The faint anodal band at the *top* of *lane 10* was seen in one family and initially distinguished as a variant, tentatively designated AMY1 8; however, in later experiments, we were not able to reproduce this result

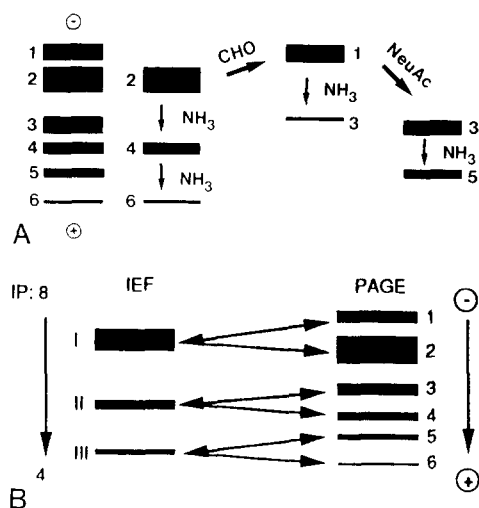

**Fig. 3A, B.** Relationship between PAGE and IEF patterns of salivary amylase. **A** Schematic representation of the salivary amylase PAGE pattern of AMY1 1 and the explanation for the origin of the different bands according to Bank et al. (1991). Arrows indicate the posttranslational modifications: CHO glycosylation; NeuAc incorporation of sialic acid in the oligosaccharide chain;  $NH_3$  deamidation. Band 2 is the primary gene product; band 1 is its glycosylated counterpart (only neutral oligosaccharide chains are present). Band 3 originates from band 1 by the binding of sialic acid to the carbohydrate moiety. Bands 4 and 6 originate from bands 2 and 4, respectively, by deamidation; band 5 is the deamidation product of amylase with an acidic oligosaccharide chain. Only a minor part of band 3 consists of the deamidation product of band 1. **B** Relationship between PAGE and IEF patterns of human salivary amylase according to Pronk and Frants (1979). The pattern shown is AMY1 1

chemical and genetic studies (Merritt and Karn 1977; Bank et al. 1991). A schematic representation of the salivary amylase pattern of the most common allozyme, AMY1 1, and the explanation for the origination of the different bands is shown in Fig. 3A. The relationships between the PAGE and IEF isozymes is shown in Fig. 3B. The IEF and PAGE patterns obtained for the other salivary amylase variants can be explained similarly.

Although the number of major bands per allozyme found with IEF is generally lower than with PAGE, the discrimination power of IEF is higher. With PAGE, the allozymes AMY1 2, AMY1 3, AMY1 5, and AMY1 10 are qualitatively indistinguishable from AMY1 1 because they comigrate with one or more of its isozymes (Fig. 4). Only homozygotes of these allozymes can be detected qualitatively because some bands are missing compared with AMY1 1. However, only AMY1 3 is known in its homozygous state (it lacks bands 1 and 2, in PAGE), whereas the other allozymes mentioned have been found only in combination with AMY1 1. Only the variant AMY1 7 can be distinguished with both techniques. AMY1 11 is the only allozyme that can be discriminated on PAGE and not on IEF; with IEF, a normal AMY1 1 pattern is seen. The electrophoretic mobility of AMY1 6 and AMY1 9 on PAGE is unknown.

Additional cathodal faint bands can be seen with IEF above the primary gene product of AMY1 1. The nature of these bands is unknown; they are present in fresh and

old whole saliva, and in parotid saliva. The number and intensity of the bands varies within one individual in samples taken at different times. In contrast to Eckersall and Beeley (1981), we could not detect genetic polymorphisms in these bands.

#### *Discrimination between different phenotypes: qualitative and quantitative variants*

Inspection of the zymograms reveals that a number of phenotypes differ from each other in a quantitative way (e.g. Fig. 1 lanes 2 and 4). Two variants, AMY1 1 and AMY1 2, are expressed in both cases, but the relative contribution of both variants to the total amount of amylase produced is different in both cases. When the primary band of AMY1 2 is compared with the secondary band of AMY1 1, it is clear that the relative intensity of AMY1 2 is much higher in lane 4 than in lane 2. Comparison with the primary band of AMY1 1 is not useful, because this band is so intense in both cases, that a reliable estimation of the amount of protein is impossible. This quantitative type of variation can be observed in different allozyme combinations. We observed no alterations of quantitative variation over a time span of 2 years in a follow-up study of a person with AMY1 1QL,2, indicating that it is unlikely that physiological conditions are involved in this type of variation.

According to the existing nomenclature, such variants are designated quantitatively elevated or quantitatively low, as indicated by the capital letters QE or QL after the number of the pertinent variant (Shows et al. 1987). Given the low frequency of the variants, it is reasonable to assume that most, if not all, variants are encoded by a single gene. Differences in intensities are therefore largely the result of a variable number of gene copies encoding AMY1 1; therefore the symbols QE and QL are used to indicate the different levels of AMY1 1. Allozyme AMY1 1 was classified as "normal" if the intensity of the variant band had a similar intensity as the secondary AMY1 1 band, i.e., if the variant band was more than half, and less than double, the intensity of the AMY1 1 band. AMY1 1 was designated QL, only if the intensity of the variant band was less than half the intensity of the secondary AMY1 1 band. If doubt existed about the classification of quantitative variants, these were run next to a known phenotype in such a dilution that the pertinent bands could be compared.

It should be kept in mind that the additions QE and QL represent relative band-intensity measurements and that care should be taken in the comparison of these quantitatively different phenotypes. As will be shown below, phenotypes AMY1 1QL, 3 and AMY1 1QL, 2 represent individuals with one and five or more AMY1 1 genes, respectively.

#### *Amylase protein variants*

During the course of this study, eight different allozymes were detected with IEF; they are schematically presented in Fig. 4. Two of these variants (AMY1 7 and AMY1 10) have not been observed before, whereas one

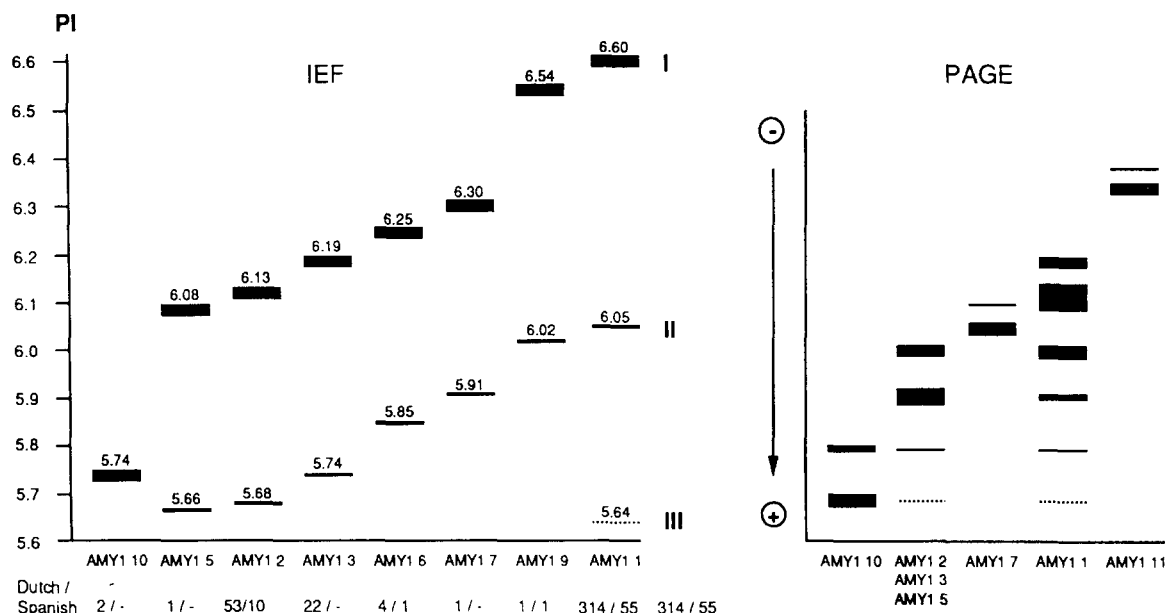

**Fig. 4.** Schematic representation of the different allozymic products of human salivary amylase on IEF and PAGE. The total number of individuals in 314 unrelated Dutch individuals and in 55 unrelated Spanish individuals in which each variant could be detected is indicated *below* each lane for the IEF variants. For the variants AMY1 7, AMY1 8 and AMY1 11, only the first two PAGE bands are drawn, because the other bands are not detectable on PAGE gels if normal quantities of saliva are loaded. The deamidation products of AMY1 10 are not drawn here, although they can be seen on the gels. Note that some allozymes are indistinguishable from each other by means of PAGE; they can be discriminated by IEF only. Note also that all allozymes consist of both glycosylated and non-glycosylated protein (odd and even PAGE bands, respectively). Other than AMY1 3, variants were never found in a homozygous state, but were always present with AMY1 1

variant, AMY1 9, has been described in the Bozo tribe (Mali, West Africa) (Pronk and Frants 1979), but not in Caucasians. AMY1 11 is probably identical with one of the PAGE variants mentioned by Merritt and Karn (1977). The variants AMY1 1, AMY1 2, AMY1 3 and AMY1 5 are in accordance with the numbers used by de Soyza (1978; 1982), Kühnl and Tischberger (1980), Pronk et al. (1982; 1984) and Boan and Caeiro (1988). The allozymes A, R1 and R2 in Pronk and Frants (1979) and Pronk et al. (1979) correspond to our numbers AMY1 1, AMY1 2 and AMY1 3, respectively. As shown by the electrophoretic mobility, the variant products in the phenotypes N, W, C, S and B of Eckersall and Beeley (1981) correspond to our allozymes AMY1 1, AMY1 3, AMY1 3, AMY1 2 and AMY1 6, respectively. We have not used the designation AMY1 4 in our nomenclature because two different allozymes have been so designated in the literature: AMY1 4 of de Soyza (1978) probably corresponds to our AMY1 6, whereas AMY1 4 of Pronk et al. (1982) (called "African variant" in Pronk and Frants 1979) is identical with AMY1 9. AMY1 8 was tentatively used by us to designate a putative new variant, segregating in one Dutch family, and is

distinguished by a faint anodal doublet with PAGE (see Fig. 2, lane 10). Although we have seen these bands in saliva samples collected at different times, we have not always been able to reproduce this result. Further biochemical studies will therefore be needed to elucidate the origin of these bands to determine whether they indeed represent another variant allozyme.

According to our classification, 22 different phenotypes have been distinguished in our study; these are depicted schematically in Fig. 5. The total number of each phenotype as found in a total of 314 unrelated Dutch individuals is indicated below each lane. In 16 of the phenotypes shown, different combinations of variants are expressed (qualitative variants), whereas 6 phenotypes can be characterized as quantitatively different (Fig. 5, lanes 3, 4, 14, 15, 18, 21). Of the unrelated Dutch individuals tested, 95% have one of three phenotypes: AMY1 1 (76%), AMY1 1,2 (including AMY1 1QE,2 and AMY1 1QL,2) (14%) and AMY1 1,3 (including AMY1 1QL,3) (4%). The remaining 5% is made up of 9 phenotypes, none of which has a frequency exceeding 2%. Furthermore, 4 phenotypes were only found to be present in family members of individuals expressing variant phenotypes (AMY1 1,2,3,10; AMY1 1,2,7; AMY1 1 1QE,3; AMY1 1QL,9). A further phenotype was found in a Spanish individual (AMY1 1,2,9), and two phenotypes in family members of Finnish individuals from the Åland islands (AMY1, 1,5 and AMY1 1QL,5).

#### Haplotypes encoding AMY1 1

Because allozyme AMY1 1 is found in the saliva of over 99% of the population (in over 76%, it is the only allozyme found), it is important to establish whether AMY1 1 is encoded by a single haplotype in all these cases, or whether different AMY1\*1 haplotypes exist. To this end, we have performed segregation analysis of families with members expressing only AMY1 1 or AMY1 1 in combination with a single variant allozyme. Some of

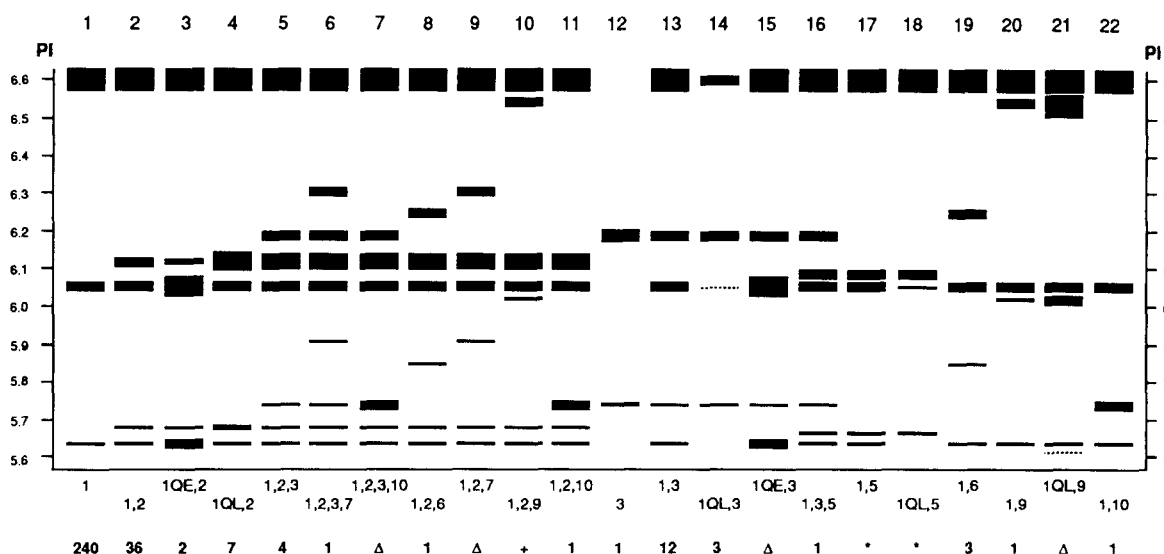

**Fig. 5.** Schematic representation of the different phenotypes obtained by IEF of saliva from Caucasians. The phenotypes shown are indicated *below* each lane, but without the prefix AMY1 (1,2,3, instead of AMY1 1,2,3). + phenotypes found in individuals of Spanish origin only; ★ phenotypes found in Swedish-speaking Finns from the Åland Islands only; Δ phenotypes found in Dutch family material only. In a group of 55 unrelated Spanish individuals, three different phenotypes were found: AMY1 1 (44 ×), AMY1 1,2 (10 ×) and AMY1 1,2,9 (1 ×). The total number of each phenotype found in 314 unrelated Dutch individuals is indicated *below* each lane. Phenotype AMY1 1,3,11 is not shown here because allozyme AMY1 11 (only recognizable with PAGE), comigrates on IEF with AMY1 1 and/or AMY1 3, and is therefore indistinguishable from AMY1 1,3. The postscripts QL and QE indicate quantitatively low or quantitatively elevated levels of AMY1 1, respectively. The phenotypes N, P, S, W and C of Eckersall and Beeley (1981) correspond to our phenotypes AMY1 1, AMY1 1, AMY1 1,2, AMY1 1,3 and AMY1 1QL,3, respectively, whereas the phenotype B is probably identical with our phenotype AMY1 1,6. The phenotypes 1, 2-1, 2, 3-1 and 3 of de Soyza (1978; 1982) correspond to AMY1 1, AMY1 1,2, AMY1 1,2, AMY1 1QL,2, AMY1 1,3 and AMY1 1QL,3, respectively, whereas phenotype 1-4 is probably identical with our phenotype AMY1 1,6. The phenotypes AA, AR1, AR2, R1R2 and "African variant" of Pronk and Frants (1979) and Pronk et al. (1979) correspond to our phenotypes AMY1 1, AMY1 1,2, AMY1 1,3, AMY1 3 and AMY1 1QL,9 respectively. Phenotypes 1-2QL, 1-3QL, 1-2QE, 1QL-3 and 1-4 of Pronk et al. (1982) are identical to the phenotypes AMY1 1QE,2, AMY1 1QE,3, AMY1 1QL,2, AMY1 1QL,3 and AMY1 1QL,9, respectively

these families are shown in Fig. 6. In pedigree A, a father (I-1) with phenotype AMY1 1QL,2 has two children (II-1 and II-2) with phenotypes AMY1 1QE,2 and AMY1 1,2, providing strong evidence for the existence of quantitatively different AMY1\*1 haplotypes. Similar conclusions can be drawn from the analysis of pedigrees C (note I-2: AMY1 1,3 and II-2: AMY1 1QL,3), D (I-2: AMY1 1QL,2 and II-1: AMY1 1QE,2), F (I-1: AMY1 1QL,5) and H (III-8: AMY 1QL,9 and III-9: AMY1 1,9). These pedigrees, and pedigrees B and E, further show that quantitatively different AMY1\*1 haplotypes exist.

It is tempting to speculate that these quantitatively different AMY1\*1 haplotypes have different gene copy

numbers of AMY1 1. In order to reveal the number of AMY1 genes in some of the discussed families that show quantitative variation at the protein level, we used the PCR technique. Mocharla et al. (1990) described a PCR that makes isozyme genotyping possible, using gene transcripts of the AMY1 and AMY2 genes, which differ from one another in length because of an insertion in intron S of the AMY1 gene. We have modified this technique by using genomic DNA instead of mRNA, and by using different isozyme-specific primers. The primers CCAGTTTCCTTTCTTAGCT (-490/-472) and ATCAACCCATCGCCATTC (+97/+114) are 100% identical for all amylase genes (for the nucleotide sequence of the region in question of AMY2A and AMY2B see Groot et al. 1988, and for that of AMY1A, AMY1B and AMY1C see Gumucio et al. 1988). In PCR these primers give rise to fragments of 604 bp (all AMY1 genes) and 582 bp (AMY2A and AMY2B) (see Fig. 7). The differences in length in the amplified region of the AMY1 and AMY2 genes is, as in the method of Mocharla et al. (1990), caused by an A-rich stretch that is present in AMY1 (nucleotide -233/-212, see Groot et al. 1988), but absent in AMY2. As the human haploid genome contains two pancreatic amylase genes (Groot et al. 1988, 1989; Gumucio et al. 1988) and a variable number of salivary amylase genes (Groot et al. 1989), the 582-bp fragment can act as an internal standard. Thus, differences in the relative intensity of the 604-bp fragment compared with the 582-bp fragment is solely caused by differences in the number of AMY1 genes (the relationship between the relative intensity and gene copy number of AMY1 is shown in Table 2).

Table 3 and Fig. 7 show the results of the PCR for the pedigrees B-E shown in Fig. 6. As a control, we used the family published by Groot et al. (1989), whose haplotypes were elucidated by Southern analysis of genomic DNA. The observed relative intensities of the PCR products of this family fit well with the expected values, indicating that the described technique is indeed highly informative (Table 3). The assumed relationship, viz., that quantitatively different AMY1\*1 haplotypes are en-

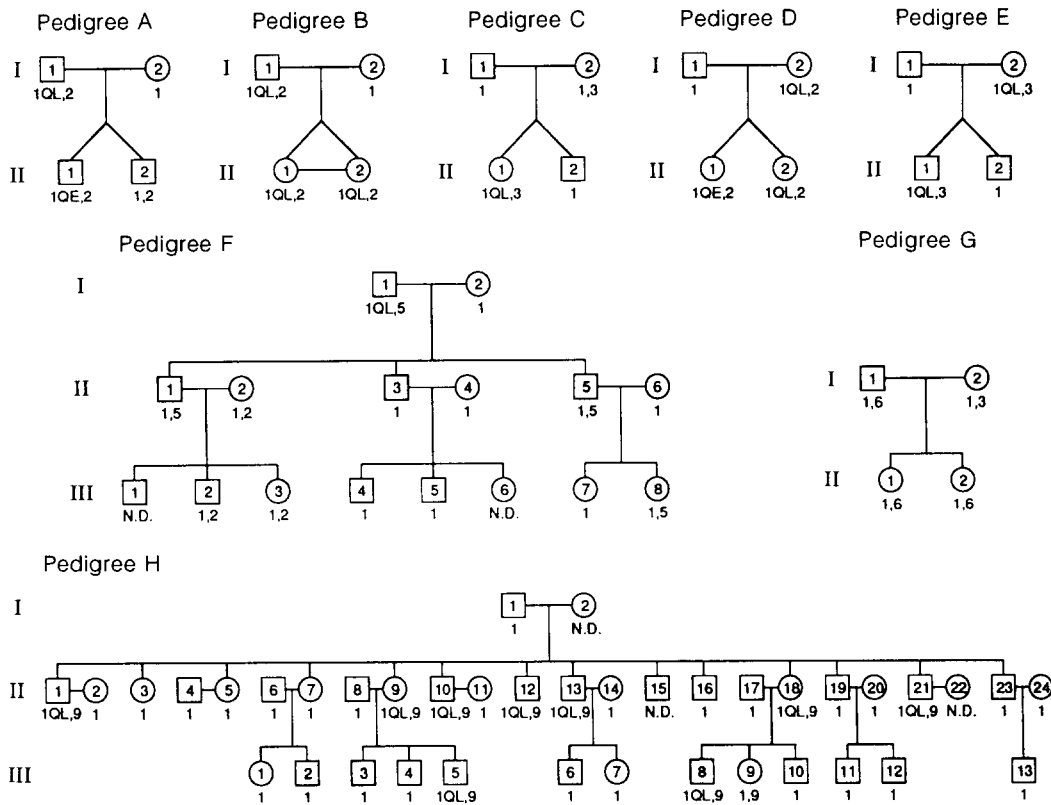

**Fig. 6.** Pedigrees showing segregation of allozymes AMY1 2 (A, B, D, F), AMY1 3 (C, E), AMY1 5 (F), AMY1 6 (G) and AMY1 9 (H)

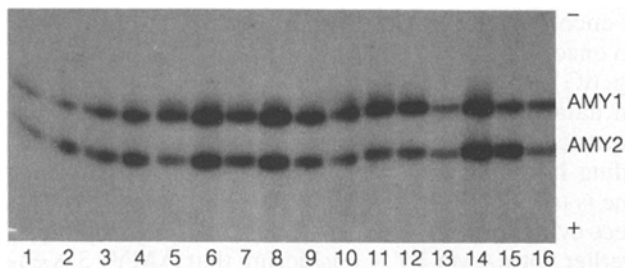

**Fig. 7.** Autoradiogram of PCR-amplified DNA of AMY1 and AMY2 genes of 4 unrelated families. Lanes 1–4 see Fig. 6, pedigree E; lanes 5–8 see Fig. 6, pedigree D; lanes 9–12 see Fig. 6, pedigree C; lanes 13–16 see Fig. 6, pedigree B

**Table 2.** Relationship between genotype, gene copy number and theoretical relative intensity of the PCR 582-bp and 604-bp products

Genotype	Gene copy number AMY2: AMY1	Relative intensity 582:604 bp
AMY*H0/*H0	4:2	1:0.5
AMY*H0/*H1	4:4	1:1.0
AMY*H0/*H2 or AMY*H1/*H1	4:6	1:1.5
AMY*H0/*H3 or AMY*H1/*H2	4:8	1:2.0
AMY*H0/*H1 or AMY*H2/*H2	4:10	1:2.5
AMY*H2/*H3	4:12	1:3.0

coded by haplotypes with different gene copy numbers of AMY1 1, closely fits for the pedigrees shown in Fig. 6C, E. We know that AMY1\*1QL and AMY1\*3 are encoded on a haplotype with a single salivary amylase gene (AMY\*H0) (Groot et al. 1989). Thus, in the case of phenotype AMY1 1QL,3, two haplotypes with one salivary amylase gene (AMY\*H0) are present. This was also found with PCR (Table 3). In the case of phenotype AMY1 1,3, one haplotype encoding AMY1 3 (AMY\*H0) and one haplotype encoding several AMY1 1 genes must be present. The latter must produce more protein than AMY\*H0, otherwise quantitative variation would not be caused in this way. Indeed, the results shown in Table 3 indicate that phenotype AMY1 1,3 is a product of the haplotypes AMY\*H0 and AMY\*H1, the latter carrying three gene copies of AMY1 1.

Contradictory results were obtained for the pedigrees B and D shown in Fig. 6. Allozyme AMY1 2 is encoded by haplotype AMY\*H2 (Groot et al. 1989). In pedigree B II-1 and II-2 (phenotype AMY1 1QL,2), one would expect the haplotype combination AMY\*H0/\*H2, but the PCR results suggest the combination AMY\*H1/\*H2. Interestingly, in three other subjects with the phenotype AMY1 1QL,2, the expected combination AMY\*H0/\*H2 agreed with the PCR results of the same run (see Table 3). Therefore, we have to conclude that the quantitatively different AMY1\*1 haplotypes are not always encoded by haplotypes with different gene copy numbers of AMY1 1. This is also illustrated by phenotype AMY1 1QE,2 (Fig. 6 pedigree D): if a correlation exists between gene copy number and quantitatively different phenotypes, one would expect the combination AMY\*H2/\*H2 or

**Table 3.** PCR-amplified DNA analysis of various families

Subject		Phenotype	Relative intensity AMY2:AMY1 <sup>a</sup>	Inferred genotype <sup>b</sup>	Expected genotype <sup>c</sup>	Discrepancy <sup>d</sup>
PCG <sup>c</sup>	I-1	AMY1 1QL,3	1:0.60/0.71	*H0/*H0	*H0/*H0	—
	I-2	AMY1 1,2,3	1:1.52/1.61	*H0/*H2	*H0/*H2	—
	II-1	AMY1 3	1:0.60/0.65	*H0/*H0	*H0/*H0	—
	II-2	AMY1 1,2,3	1:1.32/1.42	*H0/*H2	*H0/*H2	—
Fig. 6B	I-1	AMY1 1QL,2	1:1.64/1.55	*H0/*H2	*H0/*H2	—
	I-2	AMY1 1	1:1.82/1.81	*H1/*H2	*H0/?	—
	II-1	AMY1 1QL,2	1:1.94/2.10	*H1/*H2	*H0/H2	+
	II-2	AMY1 1QL,2	1:2.14/2.10	*H1/*H2	*H0/H2	+
Fig. 6C	I-1	AMY1 1	1:1.09/0.99	*H0/*H1	*H0/?	—
	I-2	AMY1 1,3	1:1.15/0.78	*H0/*H1	*H0/*H1 or *H2	—
	II-1	AMY1 1QL,3	1:0.75/0.49	*H0/*H0	*H0/*H0	—
	II-2	AMY1 1	1:— /1.48	*H1/*H1	?/?	—
Fig. 6D	I-1	AMY1 1	1:1.92/2.00	*H0/*H3	*H0/*H3	—
	I-2	AMY1 1QL,2	1:1.30/1.28	*H0/*H2	*H0/*H2	—
	II-1	AMY1 1QE,2	1:1.18/1.23	*H0/*H2	*H2/*H3	+
	II-2	AMY1 1QL,2	1:1.36/1.31	*H0/*H2	*H0/*H2	—
Fig. 6E	I-1	AMY1 1	1:0.98/0.82	*H0/*H1	?/*H1 or *H2	—
	I-2	AMY1 1QL,3	1:0.56/0.50	*H0/*H0	*H0/*H0	—
	II-1	AMY1 1,3	1:1.02/0.91	*H0/*H1	*H0/*H1 or *H2	—
	II-2	AMY1 1	1:1.14/0.92	*H0/*H1	*H0/?	—

<sup>a</sup> Results obtained from two consecutive runs

<sup>b</sup> Deduced from the relative intensity of the PCR products, in combination with segregation analysis

<sup>c</sup> Deduced from the phenotype, in combination with segregation analysis

<sup>d</sup> Discrepancy between inferred and expected genotype

<sup>e</sup> For this family see Fig. 1 of Groot et al. (1989). It serves as a control for the reliability of the PCR-experiments (see also under "Haplotypes encoding AMY1 1")

AMY\*H3/\*H2, but the PCR results suggest rather that the combination AMY\*H0/\*H2 is present. This means that quantitatively different phenotypes are caused by 1) differences in gene copy number of AMY1 1, and/or 2) differences in the transcription or translation efficiency between the AMY1 1 genes in the different haplotypes.

We have further evidence that the same gene copy number can give different amounts of protein levels. In the individual with the phenotype AMY1 1,2,3 (genotype elucidated by us previously; Groot et al. 1989), there are four copies of the allozyme AMY1 1 and one copy of both AMY1 2 and AMY1 3. However, in the zymograms, the intensity of the primary and secondary products of AMY1 2 is higher compared with that of AMY1 3. This was also observed in all other individuals expressing AMY1 1, AMY1 2 and AMY1 3 together. The higher relative intensity of AMY1 2 is also observed when the zymograms are stained with Coomassie Brilliant Blue (data not shown); the different intensities cannot therefore be explained by assuming that AMY1 2 has a higher enzymatic activity than AMY1 3. Indeed, no differences are observed in the pH and temperature optima curves of AMY1 1, AMY1 2 and AMY1 3, neither could we find differences in thermostability tests, the apparent Km value and the affinity for hydroxyapatite (W. Jansen and J. C. Pronk, unpublished observations).

#### *Haplotypes encoding variant allozymes*

AMY1 2 is encoded by a haplotype that also encodes AMY1 1 as shown by salivary amylase polymorphism

studies (Pronk et al. 1982) and DNA analysis (Groot et al. 1989). To date, the other allozymes, except for AMY1 3, have always been found together with AMY1 1, making it difficult to establish whether these variants are encoded by a single AMY1 gene or by a haplotype also encoding AMY1 1 (as in AMY1\*1,2). For AMY1 6 (Fig. 6G) and AMY1 9 (Fig. 6H), the limited segregation data do not allow conclusions about this, and the frequency of these variants is so low that the chance of finding homozygotes (if they exist) is very small. The same is true for AMY1 5 (Fig. 6F), although we have indirect evidence that AMY1 5 is located on a haplotype together with AMY1 1. Considering that AMY1 3 is encoded by the haplotype AMY1\*3 (Groot et al. 1989), we have to conclude, from the Dutch individual with phenotype AMY1 1,3,5, that she has the genotype AMY1\*3/\*1,5. Unfortunately, no family data of this person are available to test this.

AMY1 10 was found in two unrelated families, whose pedigrees are shown in Fig. 8. Pedigree B shows an individual (II-9) with the presence of four allozymes. As AMY1 3 is encoded by AMY1\*3, II-9 must have been AMY1 1, AMY1 2 and AMY1 10, transmitted from one of the parents. The simultaneous expression can be explained by assuming the presence of a triplicated gene AMY1\*1,2,10. As II-1 and II-4 expresses the phenotype AMY1 1, and II-5 and II-8 express AMY1 1,3, it can be concluded that their parents had the haplotypes AMY1\*1/\*3 and AMY1\*1/\*1,2,10. In pedigree A, allozyme AMY1 10 is not linked with AMY1 2, and is therefore located on another haplotype. This seems conflict-



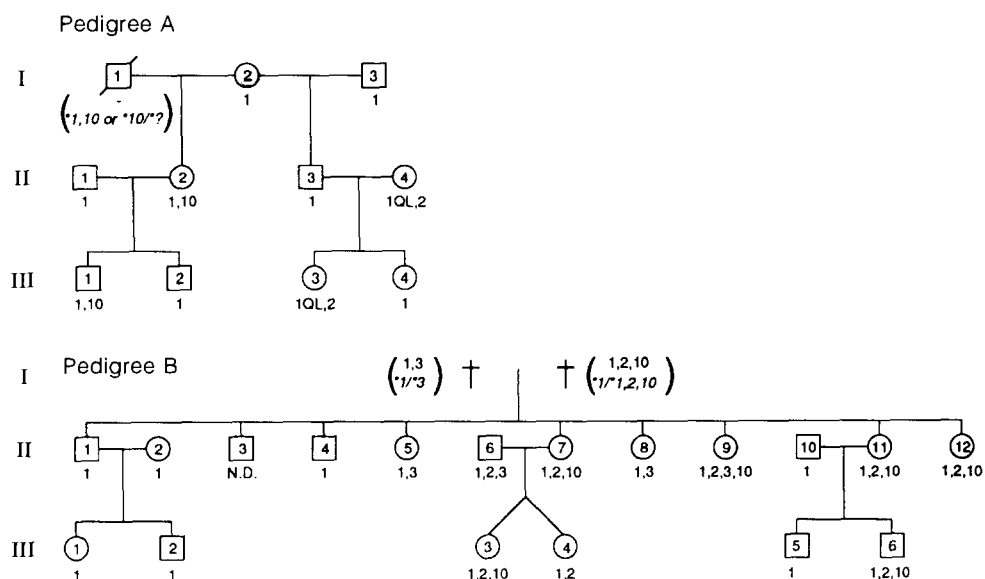

**Fig. 8.** Pedigrees showing segregation of allozyme AMY1 10

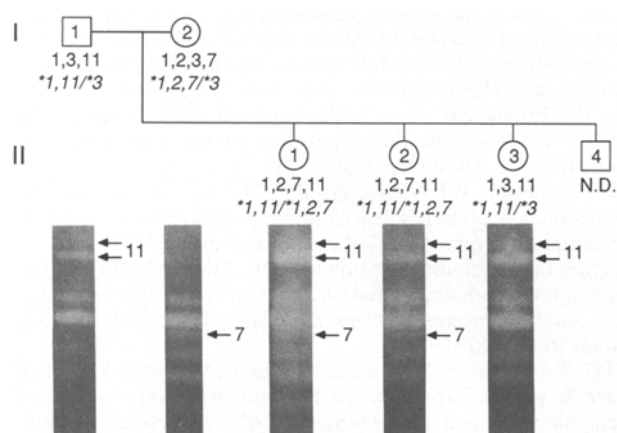

**Fig. 9.** Pedigree of a family expressing AMY1 1, AMY1 2, AMY1 3, AMY1 7 and AMY1 11. The PAGE patterns are shown below each individual. Arrows indicate the primary products of AMY1 11 and AMY1 7

ing, but we have insufficient data to predict whether the variants found in these families are indeed identical. It is possible that two independent mutations led to the existence of identical or comigrating variants in the two families.

The only electrophoretic variant, AMY1 11, was found once, in a family in which four IEF variants were present. The pedigree of this family is shown in Fig. 9, together with the PAGE patterns of its members; the segregation of both AMY1 11 and AMY1 7 is indicated by the arrows. Assuming that AMY1 3 is encoded by the haplotype AMY1\*3 (Groot et al. 1989), this remarkable family can be explained by postulating the haplotypes AMY1\*1,2,7 and AMY1\*1,11 (Fig. 9).

#### Concluding remarks

A distinction must be made between the designation of genotypes at the protein level and at the DNA level

(Table 1), with respect to the amylase multigene family. The structure of a DNA haplotype tells us how many salivary amylase genes are present, but not which allozymes are encoded by them. This can be illustrated by the genotypes encoding AMY1 3 and AMY1 1QL,3. At the protein level, the genotypes are AMY1\*1/\*3 and AMY1\*3/\*3, but at the DNA level, the genotypes are in both cases AMY1\*H0/AMY1\*H0 (Groot et al. 1989). Thus it has not been possible to distinguish the salivary amylase genes encoding AMY1 1 and AMY1 3 at the DNA level, and as a consequence of this, these haplotypes are considered to be identical, even though we know that there must be at least one difference (a mutation leading to an amino acid substitution altering the charge of the protein).

The reported variation in salivary amylase gene copy number (Groot et al. 1989) makes it likely that the increase in gene copy number preceded the occurrence of most (if not all) allozymes. At present, we have only limited data, at the DNA level, about the distribution of different haplotypes, because only a limited number of individuals have been examined. A tentative estimate is that AMY1\*H0 (one salivary gene), AMY1\*H1 (three salivary genes) and AMY1\*H2 (five salivary genes) have frequencies of about 20%, 70% and 10%, respectively, whereas the haplotypes with more than five genes will not exceed a combined frequency of 2% (P.C. Groot et al., unpublished data).

A similar rough estimate of the haplotype with one salivary gene can be made based on the population data. The number of phenotypes AMY1 1QL,2, (7 individuals) divided by the total number of phenotypes with AMY1 1,2 (45 individuals) results in a frequency of 15.6% for this short haplotype encoding AMY1 1. To this percentage, we must add the frequency of the short haplotypes encoding other allozymes. The only such haplotype with a reasonable frequency (3.5%) is the one encoding AMY1 3. This results in a total frequency for the one salivary gene haplotype of approximately 19%, which agrees well with the DNA data.

The combined frequencies of only two variants, AMY1 1 and AMY1 2, add up to a total of 98% in the population. This fact, combined with the reported high homology between all amylase genes, and especially between all salivary amylase genes (Gumucio et al. 1988; Groot et al. 1988, 1989; Samuelson et al. 1988), suggest that the evolutionary age of the human amylase genes is young, i.e., that all salivary amylase genes are recently derived from a common ancestral gene. Interestingly, not a single nucleotide mutation has been found between exon 1, intron 1, the nontranslated exon and the promoter region of the three salivary amylase genes (Gumucio et al. 1988). Consequently, an equal expression of all salivary amylase genes, regardless of the allozyme that they encode, might be expected. This is not the case: as stated above (see under "Haplotypes encoding AMY1 1"), we have evidence that differences in expression between different salivary amylase genes exist. The nature of these differences remains to be elucidated.

*Acknowledgements.* We are most grateful to the members of the families described in this paper for their generous cooperation. We wish to express our gratitude to Professor A. W. Eriksson for providing us with salivary samples from the Åland Islands.

## References

- Bank RA, Hettema EH, Arwert F, Nieuw Amerongen AV, Pronk JC (1991) Electrophoretic characterization of posttranslational modifications of human parotid salivary  $\alpha$ -amylase. *Electrophoresis* 12:74–79
- Boan F, Caciro JLB (1988) Salivary enzyme polymorphisms (Set, Sgd and AMY1) in the Galician population. *Hum Hered* 38:83–90
- Curby WA (1953) Device for collection of human parotid saliva. *J Lab Clin Med* 41:493–496
- Eckersall PD, Beeley JA (1981) Genetic analysis of human salivary  $\alpha$ -amylase isozymes by isoelectric focusing. *Biochem Genet* 19:1055–1062
- Eckersall PD, Mairs RJ, Beeley JA (1981) An improved procedure for isoelectric focusing of human salivary proteins. *Arch Oral Biol* 26:727–733
- Groot PC, Bleeker MJ, Pronk JC, Arwert F, Mager WH, Planta RJ, Eriksson AW, Frants RR (1988) Human pancreatic amylase is encoded by two different genes. *Nucleic Acids Res* 16:4724
- Groot PC, Bleeker MJ, Pronk JC, Arwert F, Mager WH, Planta RJ, Eriksson AW, Frants RR (1989) The human  $\alpha$ -amylase multigene family consists of haplotypes with variable numbers of genes. *Genomics* 5:29–42
- Gumucio DL, Wiebauer K, Caldwell RM, Samuelson LC, Meisler MH (1988) Concerted evolution of human amylase genes. *Mol Cell Biol* 8:1197–1205
- Kauffman DL, Watanabe S, Evans JR, Keller PJ (1973) The existence of glycosylated and non-glycosylated forms of human submandibular amylase. *Arch Oral Biol* 18:1105–1111
- Kühnl P, Tischberger H (1980) Amylase1 polymorphism of human parotid saliva: detection of a new allele, AMY1/5, by isoelectric focusing and AMY1 population data from Germany. *Electrophoresis* 1:186–190
- Merritt AD, Karn RC (1977) The human  $\alpha$ -amylases. *Adv Hum Genet* 8:135–234
- Mocharla H, Mocharla H, Hodes ME (1990) Coupled reverse transcription-polymerase chain reaction (RT-PCR) as a sensitive and rapid method for isozyme genotyping. *Gene* 93:271–275
- Muus J, Vnenchak JM (1964) Isozymes of salivary amylase. *Nature* 204:283–285
- Nishide T, Emi M, Nakamura Y, Matsubara K (1986) Corrected sequences of cDNAs for human salivary and pancreatic  $\alpha$ -amylases. *Gene* 50:371–372
- Ogita S (1966) Genetico-biochemical studies on the salivary and pancreatic amylase isozymes in human. *Med J Osaka Univ* 16:271–286
- Pronk JC (1977) A genetic variant of amylase from human parotid saliva detected by isoelectric focusing. In: Radola BJ, Graesslin D (eds) *Electrofocusing and isotachopheresis*. De Gruyter, Berlin, pp 359–366
- Pronk JC, Frants RR (1979) New genetic variants of parotid salivary amylase. *Hum Hered* 29:181–186
- Pronk JC, Jansen WJ, Pals G, Eriksson AW (1979) Genetic polymorphism of amylase in human parotid and whole saliva; a comparative study. 8th International Congress of the Society for Forensic Haemogenetics, 1979. London, pp 463–467
- Pronk JC, Frants RR, Jansen W, Eriksson AW, Tonino GJM (1982) Evidence for the duplication of the human salivary amylase gene. *Hum Genet* 60:32–35
- Pronk JC, Jansen WJ, Pronk A, Pol CFAM v d, Frants RR, Eriksson AW (1984) Salivary protein polymorphism in Kenya: evidence for a new AMY1 allele. *Hum Hered* 34:212–216
- Samuelson LC, Wiebauer K, Gumucio DL, Meisler MJ (1988) Expression of the human amylase genes: recent origin of a salivary amylase promoter from an actin pseudogene. *Nucleic Acids Res* 16:8261–8276
- Sato TG, Tsunasawa S, Nakamura Y, Emi M, Sakiyama F, Matsubara K (1986) Expression of the human salivary  $\alpha$ -amylase gene in yeast and characterization of the secreted protein. *Gene* 50:247–257
- Shows TB, et al (1987) Guidelines for human gene nomenclature. (9th International Workshop on Human Gene Mapping) *Cytogenet Cell Genet* 46:12–28
- Skude G (1972) Thin-layer electrofocusing following by electrophoresis in antibody containing gel. *Scand J Lab Invest* 29 [Suppl] 55–58
- Soyza K de (1978) Polymorphism of human salivary amylase. A preliminary communication. *Hum Genet* 45:189–192
- Soyza K de (1982) Determination of phenotypes of salivary amylase in liquid saliva and saliva stains. *Forensic Sci Int* 20:1–7
- Tsuchida S, Ikemoto S (1987) Genetic polymorphism of human parotid salivary amylase detected by isoelectric focusing electrophoresis and silver staining. *Forensic Sci Int* 35:159–163
- Wolf RO, Taylor LL (1967) Isoamylases of human parotid saliva. *Nature* 213:1128–1129
- Zabel BU, Naylor SL, Sakaguchi AY, Bell GI, Shows TB (1983) High-resolution chromosomal localization of human genes for amylase, proopiomelanocortin, somatostatin, and a DNA fragment (D3S1) by in situ hybridization. *Proc Natl Acad Sci USA* 80:6932–6936