

Familial influences on sustained attention and inhibition in preschoolers

Alexia S. Groot,¹ Leo M.J. de Sonneville,² John F. Stins,¹
and Dorret I. Boomsma¹

¹Free University of Amsterdam, The Netherlands; ²Vrije Universiteit Medical Center, Amsterdam, The Netherlands

Background: In this study several aspects of attention were studied in 237 nearly 6-year-old twin pairs. Specifically, the ability to sustain attention and inhibition were investigated using a computerized test battery (Amsterdam Neuropsychological Tasks). Furthermore, the Teacher's Report Form (TRF) was filled out by the teacher of the child and the attention subscale of this questionnaire was analyzed. **Methods:** The variance in performance on the different tasks of the test battery and the score on the attention scale of the TRF were decomposed into a contribution of the additive effects of many genes (A), environmental effects that are shared by twins (C) and unique environmental influences not shared by twins (E) by using data from MZ and DZ twins. **Results:** The genetic model fitting results showed an effect of A and E for the attention scale of the TRF, and for some of the inhibition and sustained attention measures. For most of the attention variables, however, it was not possible to decide between a model with A and E or a model with C and E. Time-on-task effects on reaction time or number of errors and the delay after making an error did not show familial resemblances. A remarkable finding was that the heritability of the attention scale of the TRF was found to be higher than the heritability of indices that can be considered to be more direct measures of attention, such as mean tempo in the sustained attention task and response speed in the Go–NoGo task. **Conclusion:** In preschoolers, familial resemblances on sustained attention and inhibition were observed. **Keywords:** Sustained attention, inhibition, preschoolers, familial influences, sex differences.

Attention serves three major functions: orienting to sensory stimuli, executive functions, and maintaining the alert state (Posner & Raichle, 1996). These varieties of attention are implemented in different neural networks, and can be subject to different pathologies (Berger & Posner, 2000). In this study we will focus on two functions of attention, namely the ability to sustain attention and executive functions; more specifically inhibition. Deficits in these functions are most likely related to ADHD (Berger & Posner, 2000). The main purpose of this study was to examine the etiology of individual differences in these parameters and to assess to what extent they are associated with individual differences in attention as rated by teachers.

Sustaining attention involves the continuous maintenance over time of alertness and receptivity for a particular set of stimuli or stimuli changes (e.g., Davies, Jones, & Taylor, 1984). Maintaining performance over time requires sustained attention to a target, the organization of appropriate responses to signals and inhibition of inappropriate responses. In attention research, the number of errors of omission (failures to detect the target stimulus) which reflect a lack of attention (e.g., Corkum & Siegel, 1993; Chhabildas, Pennington, & Willcutt, 2001) and commission errors (responses to a non-target stimulus) which reflect lack of inhibition (or impulsivity) respectively are frequently calculated along with reaction times. Trends with time on task in attention measures are usually examined by investigating the difference in performance in a first block of the task

and a last block of the task, as well as the session means (Weissberg, Ruff, & Lawson, 1990). In addition, decision-theory indices are also frequently measured in sustained attention tasks, in particular measures of sensitivity in signal detection (d') and bias (β) derived from signal detection theory (Davies et al., 1984).

Several studies have found that these measures of attention are good predictors of behavioral problems. With respect to (lack of) inhibition, Kalff et al. (in press) found that the proportion of omission errors on a Go–NoGo task was higher in 5/6-year-old children with ADHD than in a control group. Furthermore, in preschoolers measures of response inhibition (using a Go–NoGo task) were found to be related to teacher ratings of hyperactivity (Berlin & Bohlin, 2002). With respect to the ability to maintain the alert state, Swaab-Barneveld et al. (2000), using a Continuous Performance Task, found that over time ADHD'ers were more variable than controls. A related finding was found by Kalff et al. (in press) using a CPT, and by Kuntsi, Oosterlaan, and Stevenson (2001) using the stop signal task. It thus seems that variability in responding is a good indicator of the ability to sustain attention. An interesting question is to what extent these measures of attention are influenced by genes. A high heritability of performance measures may ultimately help in identifying genes responsible for complex psychiatric traits, such as ADHD. In the present study the question of whether individual differences in sustained attention task and Go–NoGo task

performance are influenced by genetic factors was addressed. By using monozygotic twins, who share all their genetic material, and dizygotic twins, who share on average half of their genetic material, the influence of genetic factors and environmental factors can be teased apart. If genetic effects are important, monozygotic twins are more similar than dizygotic twins in test performance. The contributions of additive genetic factors, shared environmental factors and unique environmental factors for explaining the variance observed for these measures can be explored using this twin design.

Attentional studies using reaction time measures in preschoolers are somewhat rare (a recent exception is the study by Bedard et al. (2002), who studied response inhibition using subjects as young as 6). In the present study sustained attention and inhibition were studied in a group of 6-year-old twins using a computerized test battery including reaction time measures. The development of the ability to sustain attention and inhibit responses has been studied in children as a function of age. Typically, the ability to sustain attention increases during the preschool years (Levy, 1980; Ruff, Capozzoli, & Weissberg, 1998; Ruff, Lawson, Parrinello, & Weissberg, 1990) and continues to improve during the primary school years (Lin, Hsiao, & Chen, 1999). Also, increasing inhibitory control can be observed during the preschool years (Levy, 1980; Reed, Pien, & Rothbart, 1984; Vaughn, Kopp, & Krakow, 1984). Inhibitory control continues to improve during the primary school years (Archibald & Kerns, 1999). The ability to sustain attention and to inhibit a response also seems to be sex related, with boys being somewhat faster and more impulsive than girls (e.g., Pascualvaca et al., 1997), and we will also investigate sex differences in our twin sample.

In addition to these performance measures of attention, we also studied behavioral ratings. Price, Simonoff, and Waldman (2001) found high heritabilities for parent ratings of hyperactivity of children at ages 2, 3, and 4. For hyperactivity in preschoolers, as rated by their teachers on a short questionnaire, Kuntsi and Stevenson (2001) obtained evidence for substantial genetic influence. Moreover, the authors found that hyperactivity and the variability of speed on the stop task share a common genetic factor. We

also analyzed teacher ratings, but using the attention subscale of the Teacher Report Form.

Method

Subjects

The sample consisted of 237 twin pairs with a mean age of 5.8 (SD .1) years old. All subjects were registered at birth with the Netherlands Twin Registry (NTR), kept by the Department of Biological Psychology at the Vrije Universiteit in Amsterdam. Of all multiple births in the Netherlands, 40–50% are registered by the NTR (Boomsma, 1998; Boomsma, Orlebeke, & van Baal, 1992). There were 52 monozygotic male twin pairs (MZM), 36 dizygotic male twin pairs (DZM), 73 monozygotic female twins pairs (MZF), 35 dizygotic female twin pairs (DZF) and 41 dizygotic opposite-sex twin pairs (DOS) in the sample. Zygosity was determined on the basis of DNA polymorphisms.

Assessment

Behavior of the children was investigated by asking the teacher of the children to complete the TRF (Teacher’s Report Form, Dutch translation) (Verhulst, van der Ende, & Koot, 1997). The questionnaire was sent to the teacher after parental consent was obtained. Children completed a series of tasks from the Amsterdam Neuropsychological Tasks (ANT) (de Sonneville, 1999). The ANT consists of a series of tasks, designed for the evaluation of attentional control in preschool children, including sustained, focused and divided attention and visuo-motor coordination paradigms. All children were visited at home and the tests were administered by trained testers. The two twins were tested in random order. Before each subtest all children had a practice session to ensure that the tasks were well understood and practiced. In this study the following subtests of the ANT were employed

Inhibition task. In this Go-NoGo task, Go signals, in response to which the subjects have to press a key, are randomly mixed with NoGo signals, in response to which subjects have to withhold their response (24 signals of each type). An example of both signals is shown in Figure 1. In each trial the signal is preceded by a warning signal of 500 ms. The imperative signal is presented for 800 ms (but disappears when a response is given within this period) with an event-rate of

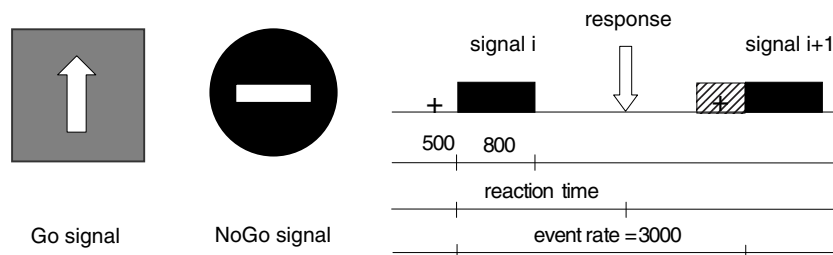

Figure 1 Example of a Go and NoGo stimulus and the timing between signals (in ms). The + sign indicates the warning signal (a cross in the center of the screen)

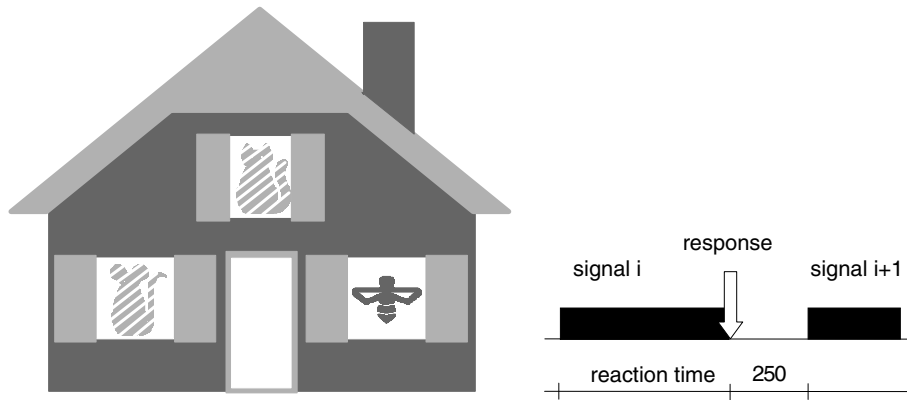

Figure 2 Example of a signal in the sustained attention task and the timing between signals (in ms). The post-response interval is 250 ms and does not contain a warning signal. The shaded animals are not shown; they serve to indicate the possible other locations of the presented animal

3000 ms. The valid response window is 200–2300 ms post stimulus onset, i.e., trials with responses faster than 200 ms post stimulus onset and trials in which the subject does not respond within 2300 ms after stimulus onset will be automatically replaced by trials of a similar type.

Sustained attention task. During this task a house is continuously present on the screen. Each trial consists of the presentation of one animal randomly in one of the windows (see Figure 2: the shaded animals indicate the other possible locations of the stimulus). In this task, 20 series of 12 trials are presented. The subjects are instructed to press the ‘yes’ key when they detect a certain animal (target signal) and the ‘no’ key when the signal does not contain this animal (non-target signal). During each series of 12 pictures, 6 targets and 6 non-targets are randomly presented. The presented animal stays on the screen until the subject presses a key. Following a response, the next stimulus is presented after 250 ms. During this task feedback was given by a beep signal on error responses. The valid response window is 200–6000 ms post stimulus onset, i.e., trials with responses faster than 200 ms post stimulus onset and trials in which the subject does not respond within 6000 ms after stimulus onset will be automatically replaced by trials of a similar type.

Scoring

Teacher’s Report Form. The attention subscale of this questionnaire was used to investigate attention problems as reported by the teacher. The subscale is calculated by summing the scores on 20 items. For each item the teacher is asked to rate on a 3-point scale (often = 2 points, sometimes = 1 point and not at all = 0 points) the behavior of a child as it is now or has been within the past two months.

Inhibition task. The mean reaction time for hits (mean RT) and the standard deviation (SD RT hits) were calculated per individual. The percentage of misses and the percentage of false alarms give an indication of the accuracy of task performance. Missed Go-signals reflect inattention and false alarms on NoGo signals reflect a lack of inhibition or impulsivity.

Sustained attention task. The mean tempo (averaged completion time per series across the 20 series in seconds) and fluctuation in tempo (the standard deviation of the 20 serial completion times) were calculated per individual. The difference between RT for correct rejections of non-targets and RT for hits was calculated and was taken to be a measure of decision speed. The reaction times of correct responses following an error response were sampled separately in order to investigate the behavioral adjustment to feedback. The latency of correct responses immediately after error responses (signaled by a beep) and the latency of regular responses were used to calculate a difference score that was taken as an index of behavioral adaptation after feedback. This shift was computed as a proportion of the regular latency: $\text{Shift} = (\text{RT}_{\text{after error}} - \text{RT}_{\text{regular}}) / \text{RT}_{\text{regular}}$.

According to Hochhaus (1972), the hit rate (the proportion of targets to which the subject responded) and the false alarm rate of yes responses made to non-targets can be transformed to d' ($\text{ABS}[\text{HitRate}] - \text{ABS}[\text{FARate}]$, an index of perceptual sensitivity) and can be interpreted as the ability of the subject to discriminate targets from distracters.

Changes with time on task were calculated per block of 5 series (4 blocks in total) with regard to mean tempo and total number of errors. The difference in scores between block 4 and block 1 were taken as changes in mean tempo and total number of errors with time on task.

Test of means

T-tests were used to investigate differences in means for the different variables between boys and girls. A p -value of less than .05 was taken as a significant difference.

Genetic analysis

Data from monozygotic (MZ) and dizygotic (DZ) twins were used to decompose the variance in performance on the different tasks of the ANT into a contribution of the additive effects of one or more genes, environmental influences that are shared by twins living in the same family and environmental influences that are not shared by twins. Resemblance between MZ twins is an effect of both their common genetic constitution and

their common environment. Because DZ twins share on average half of their genetic material, the common environment contributes fully, but genetic factors only partly, to their resemblance.

Pearson correlations were calculated for the different attention measures between first-born and second-born twins for all zygosity groups. A first indication of the heritability can be derived by doubling the difference between correlations for MZ twins and those for DZ twins [$h^2 = 2(r_{MZ} - r_{DZ})$] (Falconer & Mackay, 1996).

A structural equation modeling approach as implemented in Mx (Neale, Boker, Xie, & Maes, 1999) was used for genetic data analysis. Variables were transformed with a logarithmical transformation ($^{10}\log(\text{var}+1)$) to obtain a normal distribution (SD RThits, Go-NoGo task). The dependent variables were analyzed using a structural equation model including three latent independent factors – additive genetic factors (A), shared or common environmental factors (C) and non-shared or unique environmental factors (E) – that influence variation in a particular measure of attention (P). A path diagram of an ACE model is presented in Figure 3. A, C and E are considered to be latent because they are not observed but deduced from the covariances of MZ and DZ twins. Because these latent factors are standardized to have a variance of 1.0, the double-headed arrow connecting them represents the correlation among them. The correlation between genetic effects in twin 1 and twin 2 is 1.0 for MZ twins and .5 for DZ twins. These between-twin correlations are represented as fixed parameters in the Mx model, as is the correlation between the common environmental factors (shared by both twins of a twin pair), which is fixed to unity for both twin groups. Parameters a, c and e represent the influence of genes, common environment and unique environment on the phenotypes (P) of twin 1 and twin 2. The total variance of the phenotype (P) = $a^2 + c^2 + e^2$. The heritability (h^2) is calculated as a^2/V_P .

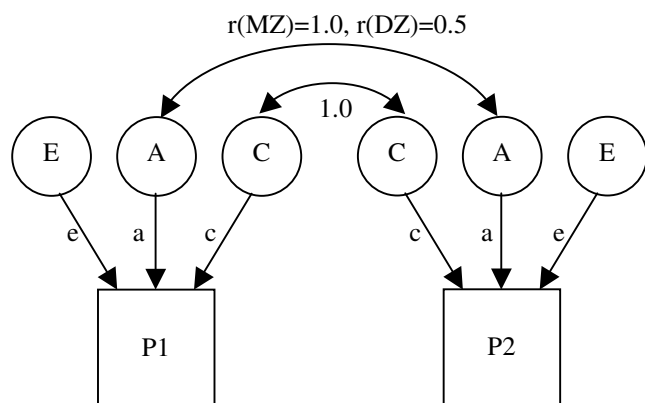

Figure 3 A path diagram of a univariate ACE model (A = additive genetic factors, C = shared or common environmental factors, E = nonshared environmental effects) in which the three latent independent variables influence variation (indicated by single-headed arrows) in a particular behavior or phenotype (P; P1 for twin 1 and P2 for twin 2). MZ = monozygotic; DZ = dizygotic. Partial regression coefficients (letters a, c and e) reflect the degree of relationship between the latent variables and the phenotype. Double-headed arrows indicate the correlations among variables

To test if parameter estimates are equal for boys and girls the fit of a model with constrained parameter estimates for a, c and e to be equal across sexes was compared to one in which they were allowed to vary. After this, the significance of c and a was investigated by dropping them one by one from the model and comparing the fit of a full model to that of a reduced model. The chi-squared statistic is computed as twice the difference between the likelihood for the full model ($-LL_0$) and that for a reduced or constrained model ($-LL_1$) ($\chi^2 = 2(LL_0 - LL_1)$) and is tested against the difference in degrees of freedom between the two models.

Results

In Tables 1 and 2 the number of subjects, means and standard deviations are shown for girls and boys for each variable for the first-born twin (twin 1) and the second-born twin (twin 2).

Table 1 shows that girls score lower on the TRF-attention scale and that girls make significantly fewer false alarms in the Go-NoGo task than boys.

Table 2 shows that in the sustained attention task the mean tempo is significantly shorter for girls than for boys. A lower fluctuation in tempo was significant only for the second-born twins. A shorter decision speed was significant only for the first-born twins. Because of the differences in RT found between the boys and girls in our study, possible differences in IQ, as measured with the short version of the Revisie Amsterdamse Kinder Intelligentie Test (RAKIT), were investigated. There was no significant sex difference in IQ which could account for the faster reaction time of the girls in our study.

To investigate the relation between the attention scale of the TRF and the experimental measures from the ANT, correlations were calculated. The correlation between the TRF attention scale and the RT hits of the Go-NoGo task, respectively the mean tempo on the sustained attention task, was .18 and .19. The correlation between the TRF attention scale and error percentage of the Go-NoGo task was .16 (false alarms), respectively .22 (misses). These results reflect slower reaction times and higher error rates in children who are rated as having more attention problems. It should, however, be kept in mind that in this (normal) population, the TRF attention scale scores lie in the normal range.

In Table 3 the twin correlations for the five zygosity groups for the TRF attention scale and the Go-NoGo task are shown.

When correlations are higher for monozygotic twin pairs than for dizygotic twin pairs genetic effects are indicated. This is the case for the TRF attention scale, the RT for hits and to a lesser extent also the percentages of false alarms and misses. In Table 4 the twin correlations for the five zygosity groups for the sustained attention task are shown.

The correlations for mean tempo and fluctuation are indicative of the influence of genetic effects.

Table 1 Number of subjects (*N*), mean and standard deviation (SD) for the Go-NoGo task for girls and boys

Variable	Sex	<i>N</i> twin 1	<i>N</i> twin 2	Mean twin 1	Mean twin 2	Range twin 1	Range twin 2	SD twin 1	SD twin 2
TRF attention (total score)	Girl	112	122	3.52*	4.32*	23	29	4.77	5.71
	Boy	100	89	6.31	6.46	31	31	6.90	7.13
RT hits (in ms)	Girl	122	133	784	789	453	499	93	91
	Boy	113	101	791	792	547	574	104	98
SD. RT hits (in ms)	Girl	122	133	152	158	269	318	56	58
	Boy	113	101	167	165	365	288	66	67
Percentage of false alarms	Girl	122	133	5.16*	4.14*	29	33	6.09	5.32
	Boy	113	101	7.41	8.25	25	33	6.68	7.77
Percentage of misses	Girl	122	133	2.97	4.07	21	17	3.84	4.77
	Boy	113	101	3.13	3.34	21	17	4.22	4.08

**t*-test showed a significant difference between boys and girls, $p < .05$.

Table 2 Number of subjects (*N*), mean and standard deviation (SD) for the sustained attention task for girls and boys

Variable	Sex	<i>N</i> twin 1	<i>N</i> twin 2	Mean twin 1	Mean twin 2	Range twin 1	Range twin 2	SD twin 1	SD twin 2
Sensitivity	Girl	120	132	3.29	3.26	3.07	3.24	.63	.63
	Boy	114	101	3.19	3.18	3.07	3.21	.64	.71
Shift	Girl	118	130	802	798	24.86	27.43	494	507
	Boy	110	95	784	815	25.68	28.93	497	498
Mean tempo (s)	Girl	120	132	16.60*	16.76*	11.54	11.34	2.37	2.12
	Boy	114	102	17.59	17.85	13.88	13.47	2.82	2.75
Fluctuation in Tempo (s)	Girl	120	132	2.42	2.47*	3.49	3.97	.83	.85
	Boy	114	102	2.62	2.81	3.86	4.87	.85	1.00
Decision Speed (ms)	Girl	121	132	192*	199	753	730	138	122
	Boy	114	102	242	213	781	706	139	423
Change in tempo with time on task	Girl	120	132	.87	.75	15.17	15.92	2.64	2.57
	Boy	114	101	.45	.45	13.52	22.88	2.49	3.41
Change in errors with time on task	Girl	120	132	.16	.12	1.50	2.20	.28	.31
	Boy	114	101	.18	.11	2.10	2.00	.34	.32

**t*-test showed a significant difference between boys and girls, $p < .05$.

Table 3 Twin correlations for the attention scale of the TRF and the variables of the Go-NoGo task

	TRF attention	RT hits	Percentage false alarms	Percentage misses	SD. RT hits
MZM	.85(44)	.64(50)	.48(50)	.27(50)	.34(50)
DZM	.60(30)	.25(36)	.49(36)	.07(36)	.39(36)
MZF	.81(65)	.50(72)	.35(72)	.42(72)	.13(72)
DZF	.27(31)	.16(35)	.26(35)	.03(35)	-.04(35)
DOS	.29(39)	.23(40)	.05(40)	.34(40)	.21(40)

Tables 5 and 6 respectively show the standardized parameter estimates for additive genetic factors (h^2), shared environmental factors (c^2) and unique environmental factors (e^2) for the best fitting, most parsimonious models per variable for the Go-NoGo task and the sustained attention task. A complete overview of the model fitting results per variable can be found in the appendix.

Table 5 shows that both for attention problems and for the reaction time on hits it was possible to drop C from the model without a significant decrease in fit, which suggests that genetic factors explain

familial resemblance. For attention problems, the proportion of variance explained by genetic factors is higher in boys (83%) than in girls (77%). For the percentage of false alarms it also was not possible to constrain A, C and E to be equal across sexes. It was possible to drop either A or C from the model but not both at the same time. For the other variables it was possible to drop either A or C from the model. A model with only E, however, significantly decreases the fit. This shows that there are familial influences for attention problems and reaction time on hits, but that it is not possible to determine whether these influences are genetic or environmental in nature.

Table 6 shows that it was possible to drop either A or C from the model for sensitivity and fluctuation in mean tempo, a measure for variability in test performance. A model with only E, however, significantly decreases the fit of the model and shows that familial influences are important. It is not possible to distinguish whether these influences are genetic or environmental in nature. For mean tempo it was possible to drop C from the model, showing that genetic factors are important. These genetic factors

Table 4 Twin correlations for the variables of the sustained attention task

	Sensitivity	Shift	Mean tempo	Fluctuation in tempo	Decision speed	Change in tempo with time on task	Change in errors with time on task
MZM	.39(52)	.24(46)	.48(52)	.23(52)	.14(51)	.03(50)	.23(50)
DZM	.40(36)	.04(35)	.24(36)	.14(36)	.08(36)	-.23(36)	-.17(36)
MZF	.76(73)	-.03(65)	.62(73)	.39(73)	.12(70)	.05(70)	.04(70)
DZF	.16(35)	.01(33)	.28(35)	.12(35)	-.18(35)	.17(35)	.09(35)
DOS	.33(41)	-.03(36)	.32(41)	.27(41)	.56(41)	.06(41)	-.08(41)

Table 5 Proportion of variance explained by h^2 , c^2 and e^2 for the attention scale of the TRF and the Go-NoGo task

TRF and Go-NoGo	h^2	c^2	e^2	Best fitting, most parsimonious
				model
Attention problems TRF <i>girls</i>	.77	.23		AE
Attention problems TRF <i>boys</i>	.83	.17		AE
RT hits	.54	-	.46	AE
% false alarms <i>girls</i>	.36	-	.64	AE or CE
		.29	.71	
% false alarms <i>boys</i>	.53	-	.47	AE or CE
		.51	.49	
% misses	.35	-	.64	AE or CE
		.26	.74	
SD RT hits*	.30	-	.70	AE or CE
		.23	.47	

are more important in boys (72%) than in girls (46%). The variance in the delay after making an error, decision speed, the RT with time on task and the number of errors with time on task was attributable only to unique environmental factors.

Discussion

In this study 237 six-year-old twin pairs were tested using a computerized test battery to measure different aspects of attention. Specifically, the ability to sustain attention and inhibition was investigated. The variance in performance on the different tasks was decomposed into a contribution of the additive effects of many genes, environmental influences that are shared by twins growing up in the same family

and environmental influences that are not shared by twins.

The heritability on the attention problems scale of the TRF was high (.77 for girls and .83 for boys). Equally high heritabilities for hyperactivity have been reported by Price et al. (2001). The score on the attention problems scale of the TRF was significantly higher for boys than for girls. The results of the Go-NoGo test showed that boys made significantly more commission errors than girls, a measure for impulsivity. This is in line with several other studies investigating attention in children (Greenberg & Waldman, 1993; Pascualvaca et al., 1997), which suggests that impulse control develops earlier in girls than in boys.

In our study girls demonstrated a shorter reaction time than boys. This is a somewhat unusual finding, as most studies show boys to be faster than girls (de Sonneville, Visser, & Licht, 1999; Greenberg & Waldman, 1993; Pascualvaca et al., 1997). Levy (1980), however, failed to find differences between boys and girls in reaction times. Because some studies found an association between IQ and performance on vigilance tasks (Pascualvaca et al., 1997; Swanson & Cooney, 1989), differences in IQ between the boys and girls participating in this study were investigated. There was no significant difference in IQ which could account for the faster reaction time of the girls.

The influence of genetic factors, shared environmental factors and unique environmental factors was estimated for all variables. For attention problems measured by the TRF, RT for hits in the Go-NoGo task and the mean tempo on the sustained attention task, an influence of genetic factors and

Table 6 Proportion of variance explained by h^2 , c^2 and e^2 for the sustained attention task

Sustained attention	h^2	c^2	e^2	Best fitting most parsimonious model
Sensitivity	.51	-	.49	AE or CE
		.44	.56	
Delay after making an error (Shift)	-	-	1	E
Mean tempo <i>girls</i>	.46	-	.54	AE
Mean tempo <i>boys</i>	.72	-	.28	AE
Fluctuation in mean tempo	.28	-	.72	AE or CE
		.21	.79	
Decision speed	-	-	1	E
Changes in tempo with time on task (block 4 - block 1)	-	-	1	E
Changes in errors with time on task (block 4 - block 1)	-	-	1	E

unique environmental factors was found. A high heritability (77% for girls, 83% for boys) was found for the attention scale of the TRF. The mean tempo on the sustained attention task showed a higher heritability for boys (72%) than for girls (46%), with the estimate for boys approaching the heritability of the attention scale of the TRF. For other variables, it was not possible to distinguish between a model including A and E or C and E. This indicates that there are familial influences but that it is not possible to determine whether these influences are genetic or shared environmental in origin. Although this study investigated almost 500 children, a lack of power may play a role as familial influences are quite low (<50%). In addition, we may point out that the natural inter- and intra-subject variability of RT measures in children of this age is high. The stability of these measures increases progressively until approximately the age of 10 and tapers off thereafter until adult levels are reached in puberty (Fietzek et al., 2000; Kail, 1991; de Sonneville et al., 2002). Test-retest correlations of ANT task measures have not been published. These correlations are not known for the age group under study. Test-retest correlations in 10–12-year-old children vary between .75 and .83, depending on type of task. In adults these correlations vary between .80 and .95 (personal communication, de Sonneville). Another possibility that must be considered is that both A and C play a role, as is the case for IQ in 5-year-olds (Rietveld, van Baal, Dolan, & Boomsma, 2000).

Few studies have investigated heritability of attentional skills using neuropsychological test batteries, and the few studies that have been done concern only adult performance. Attentional studies using reaction time measures in children under the age of 6 are rare. It is known that the heritability of performance indices may vary with age. It is important to determine the genetic and environmental contribution to the young child's attentional skills, as lack of these skills, as seen for example in children with attention deficit hyperactivity disorder, may interfere with cognitive and social development. A remarkable finding is the fact that the heritability of the attention scale of the TRF, a questionnaire, was found to be higher than the heritability of indices that can be considered to be more direct measures of attention, such as mean tempo in the sustained attention task and response speed in the Go-NoGo task. It might be hypothesized that the teacher's insight into the child is collected over a longer period of time as opposed to a neuropsychological test battery, a measure of performance of one moment in time in the child's behavior, and possibly a better indicator of the child's liability to develop attention problems. On the other hand, the lack of correspondence in genetic components between behavior ratings and laboratory measures is a common finding, suggesting that these parameters may represent different functional aspects.

Acknowledgements

This study has been supported by Zorg Onderzoek Nederland (grant nr 28-2523), The Hague, The Netherlands and the Netherlands Organization for Scientific Research (NWO-904-57-94).

Correspondence to

Dorret I. Boomsma, Department of Biological Psychology, Free University of Amsterdam, Van der Boechorststraat 1, 1081 BT Amsterdam, The Netherlands; Tel: 020-4448787; Fax: 020-4448832; Email: dorret@psy.vu.nl

References

- Archibald, S.J., & Kerns, K.A. (1999). Identification and description of new tests of executive functioning in children. *Child Neuropsychology*, 5, 115–129.
- Bedard, A.-C., Nichols, S., Barbosa, J.A., Schachar, R., Logan, G.D., & Tannock, R. (2002). The development of selective inhibitory control across the lifespan. *Developmental Neuropsychology*, 21, 93–111.
- Berger, A., & Posner, M.I. (2000). Pathologies of brain attentional networks. *Neuroscience and Biobehavioral Reviews*, 24, 3–5.
- Berlin, L., & Bohlin, G. (2002). Response inhibition, hyperactivity and conduct problems among preschool children. *Journal of Clinical Child and Adolescent Psychology*, 31, 242–251.
- Boomsma, D.I. (1998). Twin registers in Europe: An overview. *Twin Research*, 1, 34–51.
- Boomsma, D.I., Orlebeke, J.F., & van Baal, G.C.M. (1992). The Dutch twin register: Growth data on weight and height. *Behavior Genetics*, 22, 247–251.
- Chhabildas, N., Pennington, B.F., & Willcutt, E.G. (2001). A comparison of the neuropsychological profiles of the DSM-IV subtypes of ADHD. *Journal of Abnormal Child Psychology*, 29, 529–540.
- Corkum, P.V., & Siegel, L.S. (1993). Is the Continuous Performance Task a valuable research tool for use with children with Attention Deficit Hyperactivity Disorder? *Journal of Child Psychology and Psychiatry*, 34, 1217–1239.
- Davies, D.R., Jones, D.M., & Taylor, A. (1984). Selective- and sustained-attention tasks: Individual and group differences. In R. Parasuraman & D.R. Davies (Eds.), *Varieties of attention* (pp. 395–447). Orlando, FL: Academic Press, Inc.
- de Sonneville, L.M.J. (1999). Amsterdam Neuropsychological Tasks: A computer-aided assessment program. In B.P.L.M. Den Brinker, P.J. Beek, A.N. Brand, F.J. Maarse, & L.J.M. Mulder (Eds.), *Cognitive ergonomics, clinical assessment and computer-assisted learning: Computers in psychology* (pp. 187–203). Lisse, The Netherlands: Swets & Zeitlinger.
- de Sonneville, L.M.J., Visser, M., & Licht, R. (1999). Attention and information processing in 4 and 5 year old children: Results of a computerized assessment technique. In B.P.L.M. Den Brinker, P.J. Beek, A.N. Brand, F.J. Maarse, & L.J.M. Mulder (Eds.), *Cognitive*

ergonomics, clinical assessment and computer-assisted learning: Computers in psychology (pp. 204–217). Lisse, The Netherlands: Swets & Zeitlinger.

de Sonneville, L.M.J., Verschoor, C.A., Njokiktjien, C., Op het Veld, V., Toorenaar, N., & Vranken, M. (2002). Facial identity and facial emotions: Speed, accuracy, and processing strategies in children and adults. *Journal of Clinical and Experimental Neuropsychology*, *24*, 200–213.

Falconer, D.S., & Mackay, T.F.C. (1996). *Introduction to quantitative genetics* (4th edn). Harlow: Longman.

Fietzek, U.M., Heinen, F., Maute, S., Hufschmidt, A., Schulte-Monting, A., Lucking, C.H., & Korinthenberg, R. (2000). Development of the corticospinal system and hand motor function: Central conduction times and motor performance tests. *Developmental Medicine and Child Neurology*, *42*, 220–227.

Greenberg, L.M., & Waldman, I.D. (1993). Developmental normative data on the Test of Variables of Attention (TOVA). *Journal of Child Psychology and Psychiatry*, *34*, 1019–1030.

Kalff, A.C., de Sonneville, L.M.J., Hurks, P., Hendriksen, J.G.M., Kroes, M., Feron, F.J.M., Steyaert, J., van Zeben, T.M.C.B., Vles, J.S.H., & Jolles, J. (in press). Speed, speed variability, and accuracy of information processing in 5/6-year-old children at risk of ADHD. *Journal of the American Academy for Child and Adolescent Psychiatry*.

Kail, R. (1991). Processing times decline exponentially during childhood and adolescence. *Developmental Psychology*, *27*, 259–266.

Kuntsi, J., Oosterlaan, J., & Stevenson, J. (2001). Psychological mechanisms in hyperactivity: I. Response inhibition deficit, working memory impairment, delay aversion, or something else. *Journal of Child Psychology and Psychiatry*, *42*, 199–210.

Kuntsi, J., & Stevenson, J. (2001). Psychological mechanisms in hyperactivity: II. The role of genetic factors. *Journal of Child Psychology and Psychiatry*, *42*, 211–219.

Levy, F. (1980). The development of sustained attention (vigilance) in children: Some normative data. *Journal of Child Psychology and Psychiatry*, *21*, 77–84.

Lin, C.C.H., Hsiao, C.K., & Chen, W.J. (1999). Development of sustained attention assessed using the continuous performance test among children 6–15 years of age. *Journal of Abnormal Child Psychology*, *27*, 403–412.

Neale, M.C., Boker, S.M., Xie, G., & Maes, H.H. (1999). *Mx: Statistical modelling* (5th edn). Department of Psychiatry, Box 126 MCV Richmond, VA 23298, USA.

Pascualvaca, D.M., Anthony, B.J., Arnold, L.E., Rebok, G.W., Ahearn, M.B., Kellam, S.G., & Mirsky, A.F. (1997). Attention performance in an epidemiological sample of urban children: The role of gender and verbal intelligence. *Child Neuropsychology*, *3*, 13–27.

Posner, M.I., & Raichle, M. (1996). *Images of mind* (revised). Washington, DC: Scientific American Books.

Price, T.S., Simonoff, E., & Waldham, I. (2001). Hyperactivity in preschool children is highly heritable. *Journal of the American Academy for Child and Adolescent Psychiatry*, *40*, 1362–1363.

Reed, M.A., Pien, D.L., & Rothbart, M.K. (1984). Inhibitory self-control in preschool children. *Merrill-Palmer Quarterly*, *30*, 131–147.

Rietveld, M.J.H., Baal, G.C.M. van, Dolan, C.V., & Boomsma, D.I. (2000). Genetic factor analyses of specific cognitive abilities in 5-year-old Dutch children. *Behavior Genetics*, *30*, 29–40.

Ruff, H.A., Capozzoli, M., & Weissberg, R. (1998). Age, individuality, and context as factors in sustained visual attention during the preschool years. *Developmental Psychology*, *34*, 454–464.

Ruff, H.A., Lawson, K.R., Parrinello, R., & Weissberg, R. (1990). Long-term stability of individual differences in sustained attention in the early years. *Child Development*, *61*, 60–75.

Swaab-Barneveld, H., De Sonneville, L.M.J., Cohen-Kettenis, P., Gielen, A., Buitelaar, J., & Van Engeland, H. (2000). Visual sustained attention in a child psychiatric population. *Journal of the American Academy of Child and Adolescent Psychiatry*, *39*, 651–659.

Swanson, H.L., & Cooney, J.B. (1989). Relationship between intelligence and vigilance in children. *Journal of School Psychology*, *27*, 141–153.

Vaughn, B.E., Kopp, C.B., & Krakow, J.B. (1984). The emergence and consolidation of self-control from eighteen to thirty months of age: Normative trends and individual differences. *Child Development*, *55*, 990–1004.

Verhulst, F.C., Van Der Ende, J., & Koot, H.M. (1997). Handleiding voor de Teacher's Report Form (TRF). Rotterdam. Afdeling Kinder- en Jeugdpsychiatrie, Sophia Kinderziekenhuis/Academisch Ziekenhuis Rotterdam/Erasmus universiteit Rotterdam.

Weissberg, R., Ruff, H.A., & Lawson, K.R. (1990). The usefulness of reaction time tasks in studying attention and organization of behavior in young children. *Developmental and Behavioral Pediatrics*, *11*, 59–64.

Manuscript accepted 7 November 2002

Appendix

Model fitting results for the attention scale of the TRF are shown in Table A1 and the results per variable for the Go-NoGo task are shown in Table A2 and for the sustained attention task in Table A3. Best fitting models are shown in bold.

Table A1 Model fitting results for the attention scale of the TRF

	-2log-likelihood	df	Δchi	Δdf	p
Attention TRF					
ACE sd	2588.394	415			
ACE nsd	2604.689	418	16.295	3	0
AE sd	2589.494	417	1.100	2	.58
CE sd	2617.278	417	28.884	2	0
E sd	2728.537	419	140.143	4	0

A = additive genetic factors, C = shared environmental factors, E = unique environmental factors, sd = sex differences, nsd = no sex differences, df = degrees of freedom, Δ = difference and p = probability.

Table A2 Model fitting results for the Go-NoGo task

	-2log-likelihood	df	Δchi	Δdf	p
RT hits					
ACE sd	5558.700	461			
ACE nsd	5560.450	464	1.75	3	.63
AE nsd	5560.450	465	0	1	1.00
CE nsd	5570.386	465	9.936	1	0
E nsd	5610.456	466	50.006	2	0
Percentage false alarms					
ACE sd	3044.630	461			
ACE nsd	3056.826	464	12.196	3	.00
AE sd	3049.045	463	4.415	2	.11
CE sd	3044.895	463	.265	2	.88
E sd	3088.249	465	43.619	4	0
Percentage misses					
ACE sd	2671.202	461			
ACE nsd	2671.997	464	.795	3	.85
AE nsd	2671.997	465	0	1	1.00
CE nsd	2675.626	465	3.629	1	.06
E nsd	269.434	466	18.437	2	0
LogSD RT hits					
ACE sd	-469.399	461			
ACE nsd	-466.260	464	3.139	3	.37
AE nsd	-465.875	465	.395	1	.53
CE nsd	-465.843	465	.417	1	.52
E nsd	-452.524	466	13.736	2	0

A = additive genetic factors, C = shared environmental factors, E = unique environmental factors, sd = sex differences, nsd = no sex differences, df = degrees of freedom, Δ = difference and p = probability.

Table A3 (Continued)

Mean tempo with time on task					
ACE sd	227.903	459			
ACE nsd	2275.441	462	4.538	3	.21
AE nsd	2275.476	463	.035	1	.85
CE nsd	2275.441	463	0	1	1.00
E nsd	2275.476	464	.035	2	.98
Errors with time on task					
ACE sd	236.103	459			
ACE nsd	239.073	462	2.970	3	.40
AE nsd	238.548	463	.525	1	.47
CE nsd	239.073	463	0	1	1.00
E nsd	239.752	464	.679	2	.71

A = additive genetic factors, C = shared environmental factors, E = unique environmental factors, sd = sex differences, nsd = no sex differences, df = degrees of freedom, Δ = difference and p = probability.

Table A3 Model fitting results for the sustained attention task

	-2log-likelihood	df	Δchi	Δdf	p
Sensitivity					
ACE sd	87.526	459			
ACE nsd	871.505	462	.979	3	.81
AE nsd	872.785	463	1.280	1	.26
CE nsd	873.507	463	2.002	1	.16
E nsd	921.495	464	49.990	2	0
Shift					
ACE sd	6842.369	441			
ACE nsd	6844.759	444	2.390	3	.50
AE nsd	6844.759	445	0	1	1.00
CE nsd	6844.974	445	.215	1	.64
E nsd	6845.571	446	.812	2	.37
Mean tempo					
ACE sd	2124.992	460			
ACE nsd	2136.131	463	11.139	3	0
AE sd	2125.011	462	.019	2	.99
CE sd	2137.909	462	12.917	2	0
E sd	2193.152	464	68.160	4	0
Fluctuation in tempo					
ACE sd	1202.320	460			
ACE nsd	1204.449	463	2.129	3	.54
AE nsd	1204.449	464	0	1	1.00
CE nsd	1204.734	464	.285	1	.59
E nsd	1216.341	465	11.892	2	0
Decision speed					
ACE sd	5887.215	460			
ACE nsd	5887.604	463	.389	3	.94
AE nsd	5892.424	464	4.820	1	.03
CE nsd	5887.604	464	0	1	1.00
E nsd	5892.424	465	4.82	2	.09