

GROUP DECISION SUPPORT FOR RESOURCE ALLOCATION DECISIONS IN THREE-PERSON GROUPS

Van Leeuwen, Jerry, Vrije Universiteit Amsterdam, De Boelelaan 1105, 1081 HV,
Amsterdam Netherlands, jvanleeuwen@feweb.vu.nl

Van der Heijden, Hans, Vrije Universiteit Amsterdam, De Boelelaan 1105, 1081 HV,
Amsterdam Netherlands, hheijden@feweb.vu.nl

Kronsteiner, Reinhard, Johannes Kepler University of Linz, Altenberger Strasse 69, 4040,
Linz, Austria, reinhard.kronsteiner@jku.ac.at

Kotis, Gabriele, Johannes Kepler University of Linz, Altenberger Strasse 69, 4040, Linz,
Austria, gabriele.kotsis@jku.ac.at

Abstract

This research studied the effects of a Group Decision Support System (GDSS) for face-to-face negotiations in three-person groups. The GDSS equipped the groups with full information about each other's individual preferences regarding a resource allocation problem. In a partial replication of a GDSS experiment, we examined the effect of this full information treatment on post-meeting consensus level, the level of integrative behaviour, and the level of distributive behaviour in the groups. 96 three-person groups participated. Groups using the GDSS reached a higher level of post-meeting consensus compared to groups not using a GDSS. This finding supports the theory that negotiators lower their demands and increase their involvement if full information is available. No support could be found for the hypothesis that the treatment had an impact on integrative or distributive behaviour.

Keywords: Group Decision Support, Group Behaviour, Group Decision Making.

1 INTRODUCTION

The value of Group Decision Support systems (GDSS) in small face-to-face meetings is not beyond dispute (Chun & Park, 1998; Fjermestad & Hiltz, 1999). A number of empirical studies report mixed benefits on measures such as group task performance and inconclusive findings on more subjective measures such as perceived decision confidence (see for example Aiken, Krosp, Shirani, & Martin, 1994; Gallupe & McKeen, 1990; Sharda, Barr, & McDonnell, 1988). These equivocal results have been attributed to a number of factors (Dennis, 1996; Gopal & Prasad, 2000), of which one is methodological: studies have used different systems with different features, and the use of different features makes it difficult to generalise the added value across multiple studies (McGrath & Hollingshead, 1994). Consequently, there has been little convergence in academic circles on “the value” of “the GDSS.”

A different approach to examine the value of GDSS usage is by looking at the way the GDSS produces differences in information availability in the group. The availability of information, in turn, is known to lead to changes in group behaviour (McGrath, Arrow, Gruenfeld, Hollingshead, & O'Connor, 1993). In the light of this approach, we do not measure the effect of “the GDSS” per se, but we measure the differential effect of information availability in the group enabled by the use of the GDSS. A theoretical lens that aligns well with this approach is the conceptualisation of a group as an information processing system (Hinsz, 1997; McGrath & Hollingshead, 1994).

The present study is a study on the effectiveness of GDSS by examining the degree to which it triggers full availability of information to all the group members at all times. Groups using a GDSS are considered to have full information, whereas groups without a GDSS start out with partial information. The effects of the treatment are examined by looking at post-meeting consensus, and the degree of integrative and distributive behaviour in the group.

2 THEORY

The terms partial and full information are borrowed from the negotiation literature. Negotiations in which the negotiators know one another's payoffs permit them to make comparisons they otherwise could not make. Providing negotiators with knowledge of one another's preferences produces different “levels” of information availability. Full information is defined as “full information to both bargainers about the payoffs to both bargainers” (Roth & Malouf, 1979, p. 579) and partial information is defined as “full information to each bargainer about his or her own payoffs and partial information about the other bargainer's payoffs” (p. 579). In natural settings, partial information is the situation that most small groups start out with.

2.1 Group Consensus

Watson (1987) studied the effects of GDSS on group consensus. Decision support was implemented by paper-and-pencil materials and by a GDSS. His hypothesis was that groups supported by the GDSS would reach higher levels of consensus compared to groups without a GDSS. The reason for this was that the presence of computer assistance could lead to more open communication and balanced participation of the group members. Group members afraid of joining the discussion verbally could influence the discussion using the GDSS. In addition, the increase in the group members' involvement would result in a greater sense of ownership of the problem, which would eventually result in an increase in consensus.

The theory notwithstanding, the empirical findings did not support an increase in group consensus that could be attributed to the use of the GDSS. One explanation offered was that the use of a GDSS was a challenge to the group, another explanation was that groups using the GDSS became procedure-

oriented instead of issue-oriented. The presence of the GDSS directs attention away from the group discussion, and group members become preoccupied with the output of the system (Watson, DeSanctis, & Poole, 1988). These explanations are connected to the usability of the particular GDSS, and one can wonder to what extent these findings are generalisable to other GDSS systems.

In a partial replication of Watson's study, this study hypothesises an increase in group consensus attributable to the GDSS use. This is in large part due because of the increased involvement in the problem and the encouragement of more equal, balanced viewpoints. In addition, more information is known to result in negotiators lowering each others demands (Siegel & Fouraker, 1960).

H1: The use of a GDSS that enables full information promotes post-meeting consensus in three-person groups.

2.2 Integrative and distributive behaviour

Influenced by literature on negotiations in dyads and small groups (e.g. Walton & McKersie, 1965), researchers have classified the behaviour of small groups in two broad types: distributive and integrative. Distributive behaviour occurs when parties are primarily focused on their own outcomes. Extreme forms involve trench digging, less extreme forms involve sticking to one's position, not disclosing one's preferences, and, in general, a competitive orientation towards the problem. Integrative behaviour occurs when parties primarily focus on the group outcome. This behaviour involves a lot of information exchange about one's preferences, a willingness to shift position if it maximises the group outcome, and, in general, a cooperative orientation. We will discuss the effect of full information availability on each type of behaviour in more detail below Integrative behaviour

Pool et al. (1991) examined Watson's data set to identify if the GDSS has any impact on the groups' behaviour of the groups. The findings indicate that the GDSS had mixed effects on the group process, but on balance the findings suggest that it was less productive to handle conflicts. Alternatively, GDSSs have a number of benefits for conflict management because GDSS can distance ideas from people, thereby defusing and depersonalising some difficult conflict situations. Empirical evidence suggests that a GDSS produce compensating effects on the group process, thereby perhaps neutralising any effect in group performance (Huang, Wei, & Tan, 1999).

An important characteristic of any group problem is its logrolling potential (Pruitt & Lewis, 1977). Logrolling refers "to a process were group members explore their trade-offs and concessions on issues of differing importance to the bargainers" (p. 165). The exchange of information enables the participants to examine the possibilities of logrolling. Logrolling is often associated with integrative behaviour because it represents a constructive tactic to maximise the joint interests of the group participants.

Integrative negotiation involves the creation and discovery of joint gains (Bazerman & Neale, 1983). However, most people tend to perceive negotiations as competitive games in which a fixed pie of resources needs to be shared between the negotiators. Therefore, a better result for one of the negotiators will only occur at the expenses of another (Bazerman & Neale, 1983). This persistent belief is known as the fixed-pie-bias: the (often incorrect) perception that one's loss is the other's gain. Unless this belief is neutralised, it is unlikely that an integrative solution can be achieved (Bazerman & Neale, 1983).

One way to overcome fixed-pie perceptions is to reveal each other's preferences and understand the preferences of the other group members (Mannix, Thompson, & Bazerman, 1989). In a two person negotiation experiment Thompson (1991) showed that the opportunity to provide information or to seek information improved the accuracy of the negotiators' judgements about the other party and led to more mutually beneficial, integrative negotiation outcomes. The negotiators' inaccurate perceptions often lead to suboptimal or inefficient outcomes because negotiators often assume that their interests are completely opposed to the other negotiator (the fixed pie perception). Accurate judgements will negotiators lead to more integrative agreements and finally to better performance.

Based on the above arguments, this study hypothesises an increase in integrative behaviour attributable to GDSS use. In sum, this is because of the increased potential for log-rolling, the potential neutralisation of the fixed-pie perceptions, and the general influence of more information exchange on the understanding of each other's position.

H2: The use of a GDSS that enables full information promotes integrative behaviour in three-person groups.

2.3 Distributive behaviour

Most negotiations are not purely win or lose, but there is often the opportunity to reach a mutual beneficial agreement. People however often fail to reach integrative agreements and consent with less satisfying outcomes, although reasonable alternatives seems to be available (Raiffa, 1982). The fixed-pie perception of the negotiator will often lead to these sub-optimal or inefficient outcomes. A low level of information exchange will result in a less adequate definition of the problem, fewer alternatives will be generated and the consequences will be less explored (Walton & McKersie, 1965). Negotiators not exchanging information are likely to stick to their fixed-pie perception, and refrain from logrolling (Thompson, 1991).

If parties are primarily focused on their own outcomes, distributive behaviour is likely to occur. The fixed pie perception may derive from the presumption that the other party has the same concerns regarding the relative importance of the issues, thus eliminating the possibility for mutually-beneficial trades (Carroll & Payne, 1991). Another cause for the fixed pie assumption could be the tendency of people to overestimate the proportion of other people who are similar to themselves (Ross, Green, & House, 1977). This might result in negotiations in distributive perceptions of the task (Thompson & Hastie, 1990).

It will take the negotiators a significant effort to overcome the fixed pie bias, because even in a negotiation with integrative potential, they will first concentrate by nature on the competitive issues (Bazerman & Neale, 1983). If the activity is competitive the negotiation may exhibit a certain instability in which the negotiator uses a defensive tactic, to prevent the opponent from finding out his own. The same instability may prevail, even if there is a cooperative setting, provided the participants are insufficiently informed. In sum, a high level of information exchange may diminish the effects of the fixed-pie perception and thus prevent distributive behaviour.

H3: The use of a GDSS that enables full information lowers distributive behaviour in three-person groups.

3 METHOD

3.1 Design

The three hypotheses were studied using a laboratory experiment. We used an one-factor between-subjects design. The treatment has two levels. The first level is the partial information setting. The second level is the full information treatment. We randomly distributed the sequence over the groups. To ensure equal cell sizes, the sequence assignment used random sampling without replacement (Keppel, 1991).

3.2 Participants

300 undergraduate students in business economics volunteered to participate in return for partial class credit. 252 participants self-selected membership of a particular group. We formed 16 three-person groups ourselves to accommodate participants who did not succeed in joining a group. After the

experiment was conducted, we invalidated the results of four groups because of technical problems (1 group, a forced membership group), being late (2 groups) and blatant lack of involvement (1 group). The result of the process was 96 three-person groups.

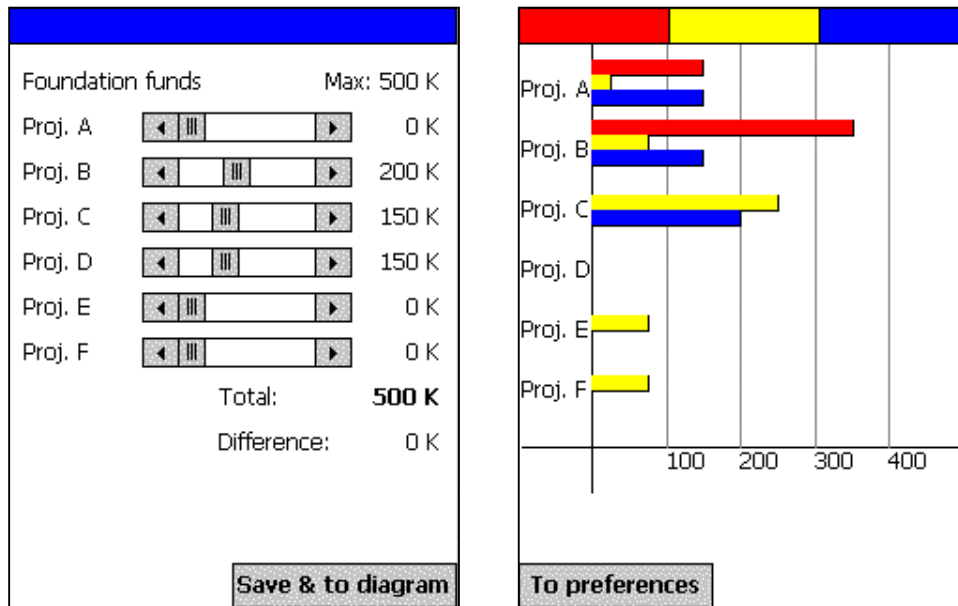

Figure 1. Screenshots of the GDSS prototype. The left screen is for preference entry, the right screen is for preference visualisation

3.3 Procedure

Each user is assigned a primary colour: red, yellow, or blue. The colour green was not chosen to avoid reading difficulties by colour-blind participants. The public screen centres around a bar chart, because bar charts are the preferred visualisation technique for comparing nominal scales. Each bar represents a preference allocation by a particular user. We used coloured bars because coloured bar charts promote quicker information retrieval than mono-coloured bar charts (Hoadley, 1990).

The system was prototyped and pretested with four distinct three-person groups in 12 sessions. These pretests confirmed the appropriateness of the system for the preference allocation task.

The following steps briefly summarise the experimental procedure.

1. Three participants enter the room and sit down at a table. The places are marked by the colours red, blue, and yellow.
2. Participants read instructions, and fill in a pre-experiment questionnaire on demographical information.
3. Participants individually allocate 500 000 Euro over six competing projects (from this allocation the pre-meeting consensus is calculated).
4. Participants engage in a group discussion and attempt to arrive at consensus. Because of scheduling constraints, the discussion time is capped at 15 minutes. The experimenter issues a warning at 10 minutes.
5. Participants again individually allocate 500 000 Euro over the six projects (the basis for the post-meeting consensus measure).

6. Participants fill in a post-experiment questionnaire, containing the peer reporting scales for integrative and distributive behaviour.

3.4 Measures

Pre- and post-meeting consensus is measured following the procedure by (Watson, 1987), based on (Spillman, Spillman, & Bezdek, 1980). Integrative behaviour and distributive behaviour has been measured both by video analysis and post hoc peer reporting. We chose the latter option. Integrative and distributive behaviour is measured using scales from a study by (Beersma & De Dreu, 2002). These scales are based on scales from De Dreu et al. (2001) who reported good reliability and validity diagnostics.

4 GROUP DECISION SUPPORT SYSTEM

To support group decisions following the experimental set up outlined in the previous section we have implemented a tool prototype for mobile devices. The hardware set-up consisted of three Personal Digital Assistants (model iPaq h5450, Hewlett-Packard Corp.) with a wireless connection to the internet to reach a central server (connection via WB-520 Access Point, Hewlett-Packard Corp.). Alternatively, another prototype was implemented based on a peer-to-peer architecture. Group members would exchange directly their opinions and votes by connecting their devices using infrared or Bluetooth communication. However, initial experiments have shown that the server based solution provided a more stable environment so we chose the first prototype as the execution platform for the experiments.

The GDSS was built using Visual C# 3.0 (Microsoft Corp.). Screenshots are provided in Figure 1, the architecture of the system is shown in Figure 2. The client consists of six main software modules. Modules presented in the GUI are for configuration, input- and output capabilities (figure 1). The first module needed by the user is the configuration module. It is necessary to identify the user by his name and assign a colour for the ongoing experiment to the user. Also the displayed consensus values are configurable. The message assembler prepares this information for the transmission to the database-server.

In each decision loop (task of allocating the money to six projects) the input module accepts the user-preferences. The user can manipulate the values using the labeled slider. During the test-phase of the system we tried also direct input in the value fields. Because of the limited input-capabilities of PDA this option was not used by the participants and therefore omitted in the final version.

The message assembler serialised the preference values into a tagged dataset. The input module proofs the validity of the data so that the maximum of 500 can't be exceeded. The maximum value is set constant at design-time.

The transmission of the tagged messages is done via a TCP/IP connection to the web server. The connection requires an internet connection but for load issues a connection to the web server running the database is only needed during data transmission (each time the input module changed the values and stores them with the save-command). The web server receives the tagged messages as a parameter of a http request calling a server-side script module.

The message-parser module on the web server is a server-side script that dissects the tagged message and uses them for update queries on the data layer. The data layer stores the transmitted decision values for further computation and provides the participants with actual information. The message assembler on the server side produces tagged messages on request. Such a request is generated every refresh loop of the clients.

The message parser on the client side dissects the tagged messages and stores them for further computation. Incomplete messages should be discarded. The consensus engine of the client derives the

group consensus out of the received messages and stored personal decision-preferences. The system is planned to work finally (in further experiments and scenarios) in an ad-hoc fashion therefore the computation load was left to the client.

The visualisation-module uses the received values to display bar chart-diagrams of the actual decision situation. These diagrams are refreshed frequently with actual data from the server. The derived group-consensus or other decision performance indicators can be configured to be displayed. The experiment showed that the participants preferred fix-scaled bar-charts for their discussions and did not accept displayed consensus- measurements. The visualisation with dynamically scaled diagrams or different types of diagrams (e.g. spider-web-diagram) was also not accepted by the participants during the test-phase.

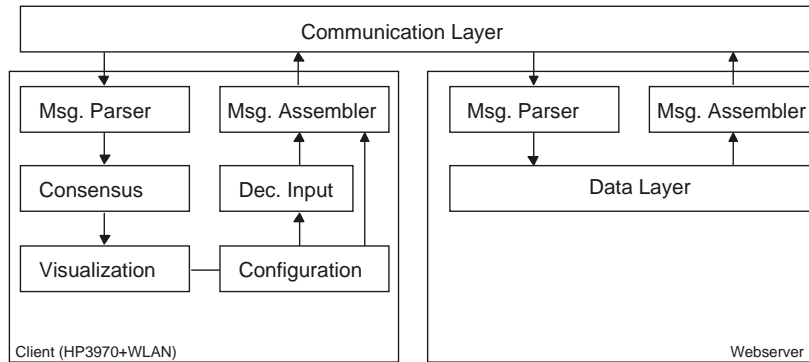

Figure 2 Architecture of the GDSS prototype.

The feedback of the participants in our experiment showed that the use of PDAs in group decision scenarios is an accepted tool to communicate dynamic information in small groups. The actual architecture allows further research in the process of group decisions by the evaluation of decision logs (the history of decisions). The given input capabilities and the configurable output distinguished our system from shared displays.

5 RESULTS

5.1 Descriptives

The mean age of the participants was 23.05 years with a standard deviation of 2.47 years. The mean of their reported working experience was 6.27 years (SD 2.98) and 16 participants joining 14 different groups reported colour blindness (all male). We found no significant performance difference between groups with and without colour-blind participants. We also found no significant performance differences between self-membership groups and forced-membership groups (see appendix for details).

The following table provides some other characteristics of the participants.

	n	%
<i>Gender</i>		
Male	196	68.1
Female	92	31.9
<i>Group Work Experience (self reported)</i>		
Very inexperienced	1	0.3
Inexperienced	12	4.2
Neutral	74	25.7
Experienced	159	55.2
Very Experienced	42	14.6
<i>PDA Experience (self reported)</i>		
Very inexperienced	191	66.3
Inexperienced	58	20.1
Neutral	22	7.6
Experienced	8	2.8
Very Experienced	9	3.1

Table 1 Characteristics of the participants (N = 288)

The following table provides the means and standard deviations for Pre-consensus and the three dependent variables Post-consensus, Integrative Behaviour and Distributive Behaviour.

	Partial Information		Full Information	
	M	SD	M	SD
Pre-consensus	0.34	0.12	0.33	0.09
Post-consensus	0.57	0.21	0.73	0.21
Integrative Behaviour	3.65	0.27	3.55	0.26
Distributive Behaviour	2.52	0.45	2.62	0.44

Table 2 Mean numbers and Standard Deviations for Consensus and Behaviour

Table 3 shows the correlations for all dependent variables. Distributive Behaviour was negatively correlated with Integrative Behaviour. There was also a negative correlation between Post-meeting Consensus and both Integrative- and Distributive Behaviour.

	Correlation among variables			
	1	2	3	4
Pre Consensus	--	.22*	.11	-.06
Post Consensus		--	-.12	-.19
Integrative Behaviour			--	-.22*
Distributive Behaviour				--

* p < .05 ** p < 0.01

Table 3 Correlations between Pre-meeting consensus, Post-meeting consensus, Integrative Behaviour and Distributive Behaviour

5.2 Reliability

Observer	Observed	Integrative Behaviour	Distributive Behaviour
Yellow	Red	.73	.73
	Blue	.79	.70
Blue	Red	.76	.80
	Yellow	.79	.77
Red	Yellow	.76	.71
	Blue	.76	.77

Table 4 Cronbach alphas

The table reveals that all the Cronbach alphas were above the 0.70 threshold for established research (Hair, Anderson, Tatham, & Black, 1998).

5.3 Tests of the hypotheses

Hypothesis 1 stated that the use of a GDSS that enables full information will result in a higher level of post post-meeting consensus compared to the situation where there is no GDSS and as a result only partial information availability. A Multivariate Analysis of Covariance (MANCOVA) supported this prediction, $F(1, 96) = 14.26, p < .001$. Hypothesis 2 predicted that as a result of the full information availability there would be an increase of integrative behaviour. Hypotheses 3 predicted that as a result of the full information availability there would be a decrease in distributive behaviour. The last two hypotheses, however, were not supported (see table 5).

	Multivariate		Univariate		
	df	F ^a	Post Consensus ^b	Integrative Behaviour ^b	Distributive Behaviour ^b
Treatment	1	6.45 ^{***}	14.26 ^{***}	3.32	1.33
Pre consensus	1	2.39	5.64 [*]	1.08	0.29

Note. Multivariate F ratios were generated from Pillai's statistic.

^aMultivariate $df = 3, 91$. ^bUnivariate $df = 1, 96$

* $p < .01$. *** $p < .001$.

Table 5 Multivariate and Univariate Analyses of Covariance

6 CONCLUSION

The result of the experiment supports the hypotheses that a GDSS making full information available will lead to a higher level of post-meeting consensus. The experiment, however, also rejects the hypotheses that the level of information influences the integrative and distributive behaviour of negotiators.

The higher level of post-meeting consensus for groups using the GDSS implies that a GDSS with full information leads negotiators to lower their demands and increase their sense of problem ownership. Another implication could be the increase of negotiation involvement. Concrete suggestions for developers of GDSS, therefore, include 1) an increased focus on a shared visualisation of the problem, and 2) ample opportunities for individual members to make changes in their personal preferences, and 3) real time feedback to all participants on changes made in personal preferences.

A possible explanation for the lack of relationship between treatment and integrative and distribute behaviour is the distance between GDSS technology and the negotiators. Conflict situations could be

depersonalised and sometimes defused. The negotiator and user of the GDSS was as a result of the depersonalised and defused situation not capable of overcoming the fixed-pie-perception. The negotiators could not start the process of logrolling. Concrete suggestions for GDSS developers to improve this situation include 1) a performance index that displays the degree of consensus, 2) emphasis on the visibility of all user preferences.

The findings of this experiment raise a number of new research questions. A possibility could be to evaluate if the effect of the GDSS can be carried over to another experimental setting. This could be an indication of the possibility to improve the consensus in a negotiation process without actually influencing the behaviour of the participants. It could also be an indication that there are other relevant factors influenced by the usage of a GDSS in a negotiation.

Another aspect not incorporated in this experiment is the personalities of the group participants themselves. Research questions could be posed such as: Do the participants have a pro-social or an egoistic motive and what will be the influence on their behaviour? This may be relevant because pro-social negotiators have the tendency to engage in integrative behaviours and egoistically motivated negotiators do show a stronger tendency to engage in distributive behaviours (Beersma, 2002).

Another development might deal with an experiment in which the GDSS is extended with more features. This could influence both the level of consensus and the behaviour, or one of the variables independently. Manipulations could also exist of changing decision rules, complicating the task or increasing the group size.

References

- Aiken, M., Krosp, J., Shirani, A., & Martin, J. (1994). Electronic brainstorming in small and large groups. *Information & Management*, 27, 141-149.
- Bazerman, M. H., & Neale, M. A. (1983). Heuristics in negotiation: Limitations to effective dispute resolution. In M. H. Bazerman & R. J. Lewicki (Eds.), *Research in organizational behavior* (Vol. 9, pp. 247-288).
- Beersma, B. (2002). *Small Group Negotiation and Team Performance.*, University of Amsterdam.
- Beersma, B., & De Dreu, C. K. (2002). Integrative and distributive negotiation in small groups: effects of task structure, decision rule, and social motive. *Organizational Behavior and Human Decision Processes*, 87(2), 227-252.
- Carroll, J. S., & Payne, J. W. (1991). An information processing approach to two-party negotiations. In M. H. Bazerman & R. J. Lewicki & B. H. Sheppard (Eds.) (Vol. 3): JAI Press Inc.
- Chun, K. J., & Park, H. K. (1998). Examining the conflicting results of GDSS research. *Information & Management*, 33, 313-325.
- De Dreu, C. K., Evers, A., Beersma, B., Kluwer, E. S., & Nauta, A. (2001). A theory-based measure of conflict management strategies in the workplace. *Journal of Organizational Behavior*, 22, 645-668.
- Dennis, A. R. (1996). Information exchange and use in group decision making: you can lead a group to information, but you can't make it think. *MIS Quarterly*(December), 433-457.
- Fjermestad, J., & Hiltz, S. R. (1999). An Assessment of Group Support Systems Experimental Research: Methodology and Results. *Journal of Management Information Systems*, 15(3), 7-149.
- Gallupe, R. B., & McKeen, J. D. (1990). Enhancing computer-mediated communication: An experimental investigation into the use of a group decision support system for face-to-face versus remote meetings. *Information & Management*, 18, 1-13.
- Gopal, A., & Prasad, P. (2000). Understanding GDSS in Symbolic Context: Shifting the Focus from Technology to Interaction. *MIS Quarterly*, 24(3), 509-546.
- Hair, J. F., Anderson, R. E., Tatham, R. L., & Black, W. C. (1998). *Multivariate data analysis* (5th ed.). Upper Saddle River, NJ: Prentice-Hall.

- Hinsz, D. A., Tindale, R. S., & Vollrath, D. A. (1997). The emerging conceptualization of groups as information processors. *Psychological Bulletin*, 121(1), 43-64.
- Hoadley, E. (1990). Investigating the effects of color. *Communications of the ACM*, 33(2), 120-125.
- Huang, W., Wei, K. K., & Tan, B. C. (1999). Compensating effects of GSS on group performance. *Information & Management*, 35, 195-202.
- Keppel, G. (1991). *Design and analysis: a researcher's handbook*. Upper Saddle River, NJ: Prentice Hall.
- Mannix, E. A., Thompson, L. L., & Bazerman, M. H. (1989). Negotiation in small groups. *Journal of Applied Psychology*, 74, 508-517.
- McGrath, J. E., Arrow, H., Gruenfeld, D. H., Hollingshead, A. B., & O'Connor, K. M. (1993). Groups, Tasks, and Technology: The Effects of Experience and Change. *Small Group Research*, 24(3), 406-420.
- McGrath, J. E., & Hollingshead, A. B. (1994). *Groups interacting with technology: ideas, evidence, issues, and an agenda*. Thousand Oaks: Sage Publications.
- Poole, M. S., Holmes, M., & DeSanctis, G. (1991). Conflict management in a computer-supported meeting environment. *Management Science*, 37(8), 926-953.
- Pruitt, D. G., & Lewis, S. A. (1977). The psychology of integrative bargaining. In D. Druckman (Ed.), *Negotiations: social-psychological perspectives* (pp. 161-189). Beverly Hills: Sage Publications.
- Raiffa, H. (1982). *The art and science of negotiation*. Cambridge: MA: Harvard Univ. Press.
- Ross, L., Green, D., & House, P. (1977). The "false consensus effect": An egocentric bias in social perception and attribution processes. *Journal of Experimental Social Psychology*, 13, 279-301.
- Roth, A. E., & Malouf, W. K. (1979). Game-theoretic models and the role of information in bargaining. *Psychological Review*, 86(6), 574-594.
- Sharda, R., Barr, S. H., & McDonnell, J. C. (1988). Decision support system effectiveness: a review and an empirical test. *Management Science*, 34(2), 139-159.
- Siegel, S., & Fouraker, L. E. (1960). *Bargaining and group decision making experiments in bilateral monopoly*. New York: McGraw-Hill.
- Simon, H. A. (1976). *Administrative Behavior: A Study of Decision-Making Processes in Administrative Organization*. New York: The Free Press.
- Spillman, B., Spillman, R., & Bezdek, J. (1980). A fuzzy analysis of consensus in small groups. In P. Wang & S. Chang (Eds.), *Fuzzy sets: theory and application to policy analysis and information systems* (pp. 291-308). New York: Plenum.
- Thompson, L. L. (1991). Information exchange in negotiation. *Journal of Experimental Social Psychology*, 27, 161-179.
- Thompson, L. L., & Hastie, R. (1990). Social perception in negotiation. *Organizational Behavior and Human Decision Processes*, 47, 98-123.
- Walton, R. E., & McKersie, R. B. (1965). *A behavioral theory of labor negotiations*. New York: McGraw-Hill.
- Watson, R. T. (1987). *A study of group decision support use in three and four-person groups for a preference allocation decision*. Unpublished doctoral dissertation, University of Minnesota.
- Watson, R. T., DeSanctis, G., & Poole, M. S. (1988). Using a GDSS to facilitate group consensus: some intended and unintended consequences. *MIS Quarterly*(September), 463-478.