

A SIMPLE CAPACITANCE SENSOR FOR VOID FRACTION MEASUREMENT IN GAS-LIQUID TWO-PHASE FLOW

Luiz. C. R. P. Silva¹, José L.H. Faccini¹, Marcos S. Farias¹, Jian Su²

¹Nuclear Engineering Institute - IEN / CNEN
21941-906, Rio de Janeiro, Brazil
reina@ien.gov.br

²Nuclear Engineering Program, COPPE
Federal University of Rio de Janeiro
21.941-914 Rio de Janeiro, Brazil
sujian@con.ufrj.br

ABSTRACT

In this work we present a simple and inexpensive capacitance sensor for time averaging void fraction measurement of gas-liquid two-phase flow, which was developed at Experimental Thermalhydraulics Laboratory in the Nuclear Engineering Institute, IEN/CNEN. The sensor is a non-invasive device causing no flow disturbances. It is formed by two parallel plates and four electronic circuits: a signal input circuit, an amplification circuit, a frequency generator, and a power supply circuit. The frequency generator applies a sinusoidal signal with appropriate frequency into the signal input circuit which converts the capacitance variation value (or void fraction) of the two-phase flow into a voltage signal that goes to the amplifier stage; the output signal of the amplifier stage will be an input to an analogical/digital converter, installed inside of a computer, and it will provide interpretation of the signal behavior. The capacitance sensor was calibrated by using a horizontal acrylic tube filled with a known volume of water.

1. INTRODUCTION

For two-phase flow of gases and liquids, the gas volume fraction, or void fraction, is one of the primary design parameters. Much effort has been devoted to developing techniques for the measurement of void fraction. The available techniques include quick-closing valves [1], radioactive attenuation [2], hot wire anemometry [3], electrical impedance methods [4, 5], and ultrasound [6].

The electrical impedance methods, in particular, are attractive and suitable for most investigators since they are simpler to use and are relatively inexpensive compared to the other techniques. Depending on the electrical characteristics of the two phases and the configuration of the sensing element, impedance can be governed by conductance or by capacitance or by both. Measurements based on capacitance generally provide better reproducibility than those based on conductance because the latter depend on ion concentration, and this can be difficult to control. For impedance sensors some design parameters as reproducibility, flow channel geometry, sensor-induced flow disturbances, flow pattern, and sensitivity must be considered. The impedance method has been carried out in many studies in different flow regimes with various methods: some used two electrodes and others used a greater number of electrodes. Conductivity probe was first proposed by Neal and Bankoff [7].

A major difficulty of impedance sensors concerns the effect of flow pattern on the relation between sensor signal and void fraction. Cimorelli and Evangelisti [8] and Bouman et al. [9] showed, theoretically, that this interaction was to be expected. They also showed that, for the annular flow pattern, the sensitivity of impedance sensors is low at high void fractions; this leads to intolerably low sensitivities for this particular flow pattern.

The technique for measuring void fraction depends on the desired application. Due to its high cost and difficulty in its implementation, the radiation-attenuation method is usually not used. In using the intrusive probes, the flow field is disturbed making it disadvantageous, [10]. Electrical impedance sensors have been developed by many researchers for measuring and monitoring void fraction in liquid-gas flow in a pipe. Stott et al. [11] developed a theory that analyzed the characteristic of concave plate electrodes fixed to a pipe internally or externally. The flow components are water-air phase flow. An experiment was conducted to validate the theory. It was proved that the capacitance and the conductance of the external electrode are both functions of permittivity and conductivity of the fluid. The result shows that it is better to use internal electrodes when measuring the permittivity of the fluid and it is better to use external electrode when there is low admittance of the fluid. Gerraets and Borst [12] developed a capacitance sensor for measuring void fractions of phase flow involving water-air flow. Helical type of electrode configuration was utilized in the work. Results revealed that one of the important design parameters is the influence of dielectric tube wall thickness. It was concluded that the time-varying output signal is essential for the identification of flow pattern identification. Elkow and Rezkallah [13, 14] developed two capacitive sensors for measuring the void fraction in vertical flow consisting air-water two-phase flow in a small diameter tube. Both concave plate and helical wound electrodes configuration were employed. The problem of nonlinearity in the flow was addressed in helical sensor and the concave plate sensor was improved based on the addressed nonlinearity in helical sensor. Results of the two sensors were compared with gamma densitometer and quick-closing valves. They show that there is good agreement between the average void fraction values and the annular flow, bubble, and the transitional flow regimes.

The aim of the present work is to develop a simple capacitance sensor [15] to measure the void fraction in two-phase gas-liquid flows without flow disturbances, and with good time-spatial resolution.

2. EXPERIMENTAL SET-UP

2.1 Electronic Set-up

Figure 1 shows an overview of the electronic set-up. The electronic set-up is formed by two electrodes which are two identical parallel half-cylinders of 0.4 mm thick aluminum foil, and length of 2.2 times the inside electrodes diameter. The electrodes are positioned exactly opposite each other outside of the 63.6 mm external diameter acrylic tube. The electrodes are connected to a signal input circuit. We can see: a signal input circuit, amplification circuit, a frequency generator, and a power supply circuit.

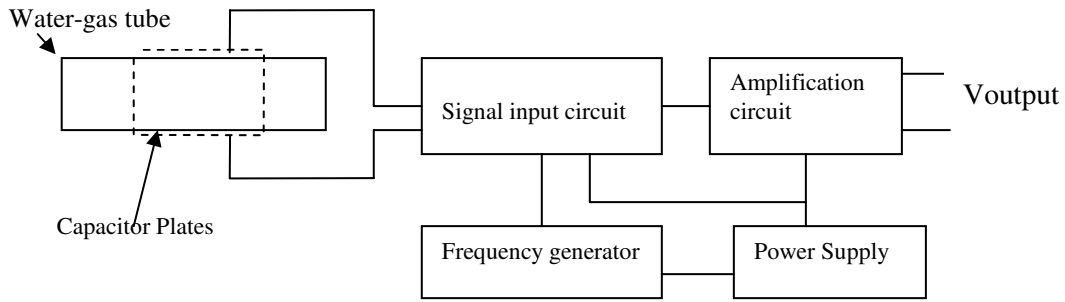

Figure 1: Electronic set-up: capacitance sensor and associated circuits.

The equation 1 is used for parallel plates [16], where C is the capacitance in pF, A is the plate area in m^2 , d is the distance between plates in meters, and K is the dielectric constant. The dielectric constant is a product of different dielectric constants according with material used.

$$C \approx 8,82.K \cdot \frac{A}{d} \quad (1)$$

We can use the equation 1 here to simplify understanding of how capacitance sensor works. In this case, we consider C as formed by two dielectric means: liquid (water) and gas (air), each one with a different dielectric constant. The dielectric constant of liquid (water), K_w is much larger than gas dielectric constant K_G , $K_w \gg K_G$. C_w is the capacitance with tube completely full of liquid and C_{air} is the capacitance with no liquid (only air).

In Fig. 2 we can see the signal input circuit. The tube is in horizontal position. The sensor capacitor is placed in series with a frequency generator and variable resistors. The additional capacitors provide a filtering action for the sensor signal. The voltage drop V_{C2} across capacitor C_2 increases as the capacitance in C increases and reversely. So the V_{out} voltage also increases and decreases according V_{C2} . Since V_{out} is small amplitude signal, it is amplified on the amplification circuit, Fig. 3.

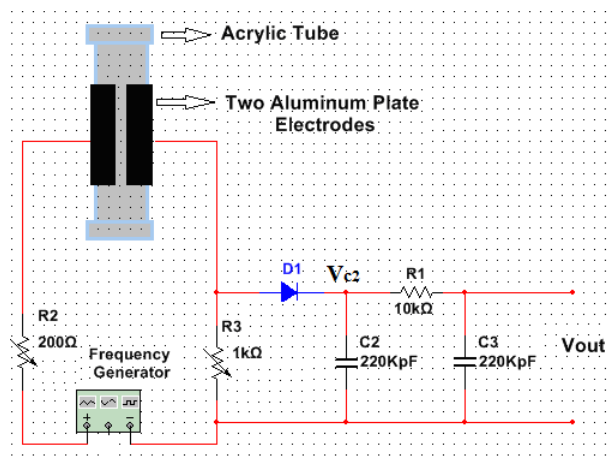

Figure 2: Signal input circuit.

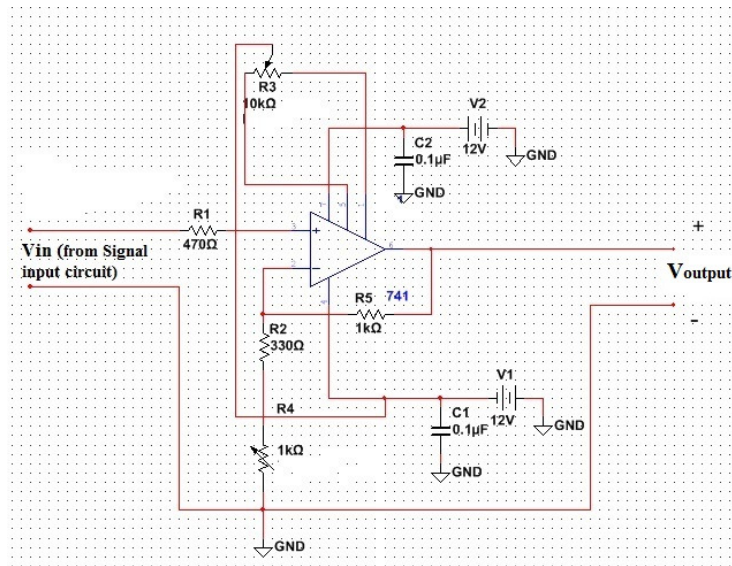

Figure 3: Amplification circuit.

2.2 Calibration Set-up

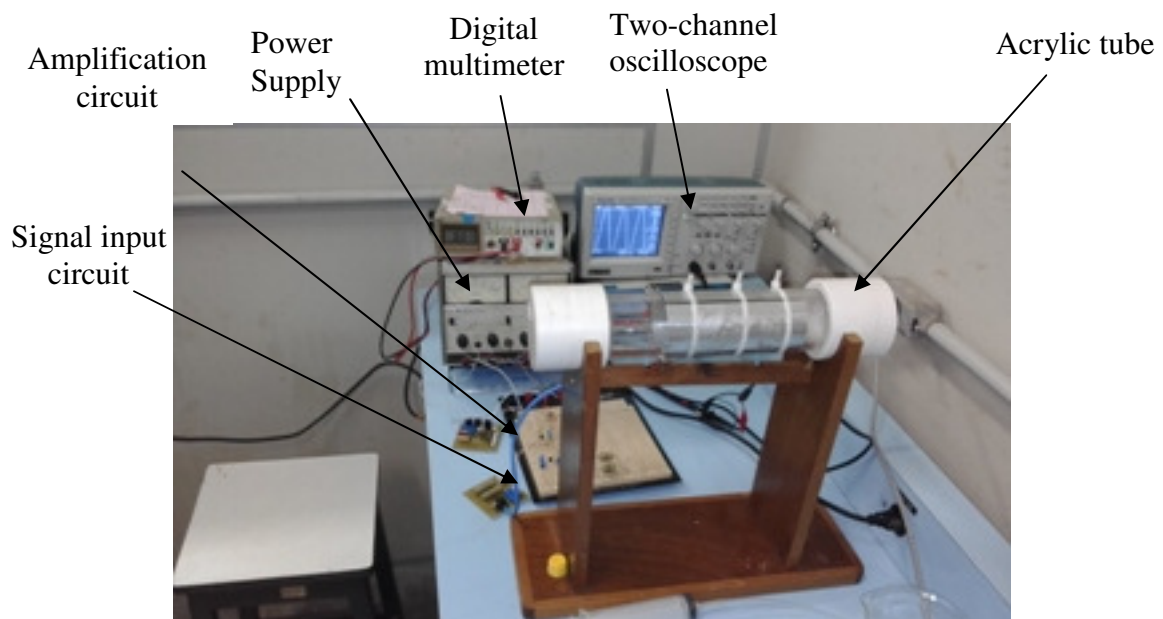

Figure 4: Experimental static set-up.

In Fig. 4 we can see a 289 mm long acrylic tube in horizontal position (external diameter 63.6 mm). This tube has two caps in its extremities. In one of them there is a 1/2" diameter hole; through this hole the water is injected and drained in the tube. The tube is supported in a wood made adjustable support. The horizontal alignment was obtained using a 0.1mm/m high precision level.

The signal input circuit converts the capacitance change in small voltage change (V_{out}). This small output voltage is amplified in the amplification circuit (V_{output}).

The ultrasonic system, applied for the capacitance sensor calibration, consisted of one transducer, a generator/multiplexer board and a computer (PC) with embedded LabView software to control the board. The ultrasonic transducer was Panametrics piezoelectric-finger type transducer, model V112, 10 MHz and 6.35 mm diameter. It was placed at the bottom of the acrylic tube along the horizontal axis direction, as it is shown in Fig. 5 The generator/multiplexer board have provided signal generation, data acquisition and analysis of the ultrasonic signals.

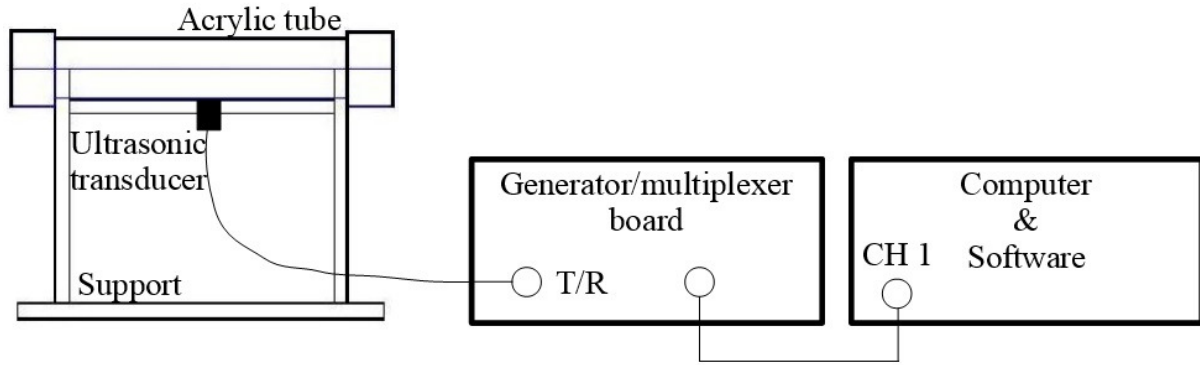

Figure 5: Ultrasonic set-up.

The calibration tests were initially performed with the empty acrylic tube. The acrylic tube was gradually filled with distilled water. The water temperature was measured using a K type thermocouple and a Fluke digital thermometer, model 714. The average temperature obtained was used to calculate the sound velocity in water, according to correlation [17]. For an amount of 50 ml of water injected into the tube corresponded to a height of liquid h_L . Measuring the transit time of the ultrasonic wave from the ultrasonic transducer until gas-liquid interface, h_L could be calculated since the sound velocity in water is known, [18]. The partial volume of the tube may be determined by the values of h_L . Thus the void fraction was obtained by the relation:

$$\alpha = \frac{V_G}{V_G + V_L}; \quad (2)$$

where α is the void fraction, V_G is the volume of gas, and V_L is the volume of liquid. Alternatively the void fraction can be expressed as

$$\alpha = 1 - \frac{V_L}{V_G + V_L}; \quad (3)$$

Similarly, the electronic circuit of the capacitance sensor gives the void fraction as:

$$\alpha^* = 1 - \frac{V_m - V_{empty}}{V_{outputM} - V_{empty}} \quad (4)$$

where α^* is the void fraction obtained from the capacitance sensor, V_m is the voltage for an amount of liquid inside the tube, V_{empty} is the voltage correspondent to $\alpha^* = 1$, and $V_{outputM}$ is the voltage for the tube full of water.

The void fraction uncertainty given by the ultrasonic system was estimated as being less or equal to 2%. The void fraction uncertainty given by the capacitance sensor system was estimated as 7.5 % due to the errors of the electronic circuits and measuring equipment used.

3. RESULTS

Figure 6 shows the values of capacitance (or the voltage V_m) given by the electronic set-up as a function of water volume, V_L , introduced into the tube. It can be seen in Fig. 6 that there is a good linear relationship between the capacitance and the liquid volume inside the tube, except for a discrepancy in the cases where the tube is empty/full.

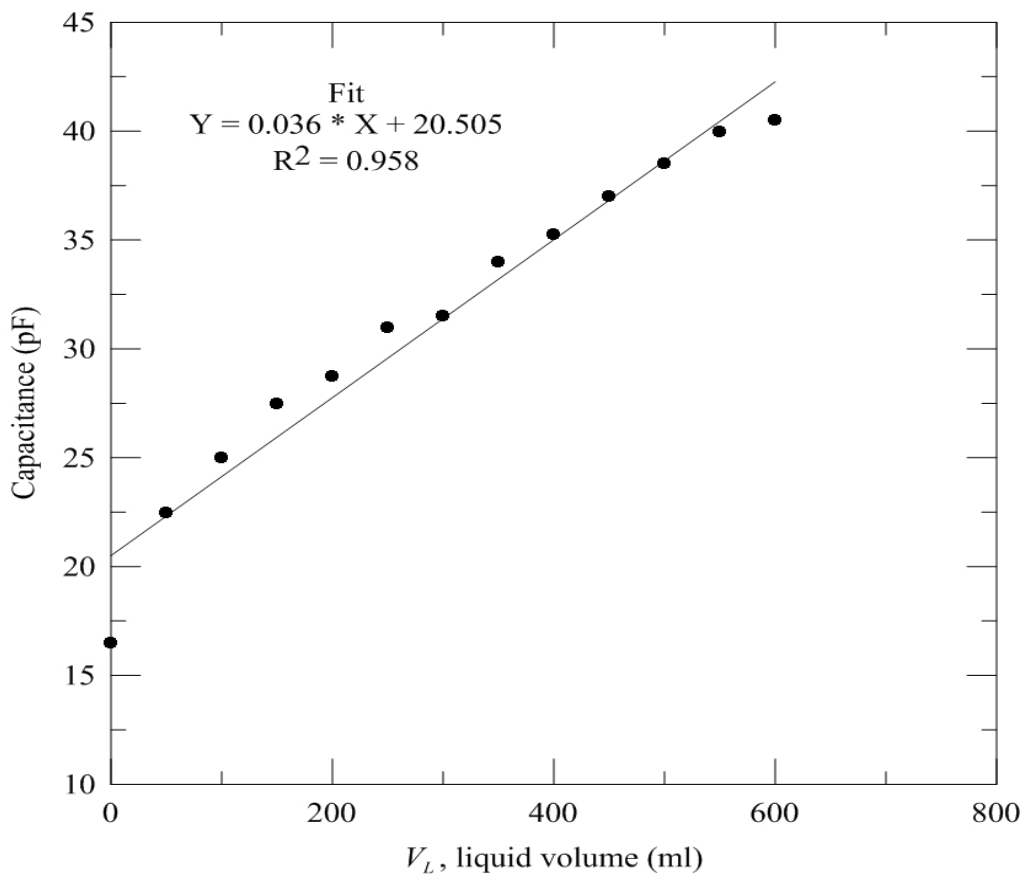

Figure 6: Capacitance as a function of liquid volume.

The results of void fraction measurements by capacitance sensor α^* , and ultrasonic system α are shown in Fig.7. We can notice again a good agreement between the two techniques, except for a small discrepancy in the case where the tube is empty.

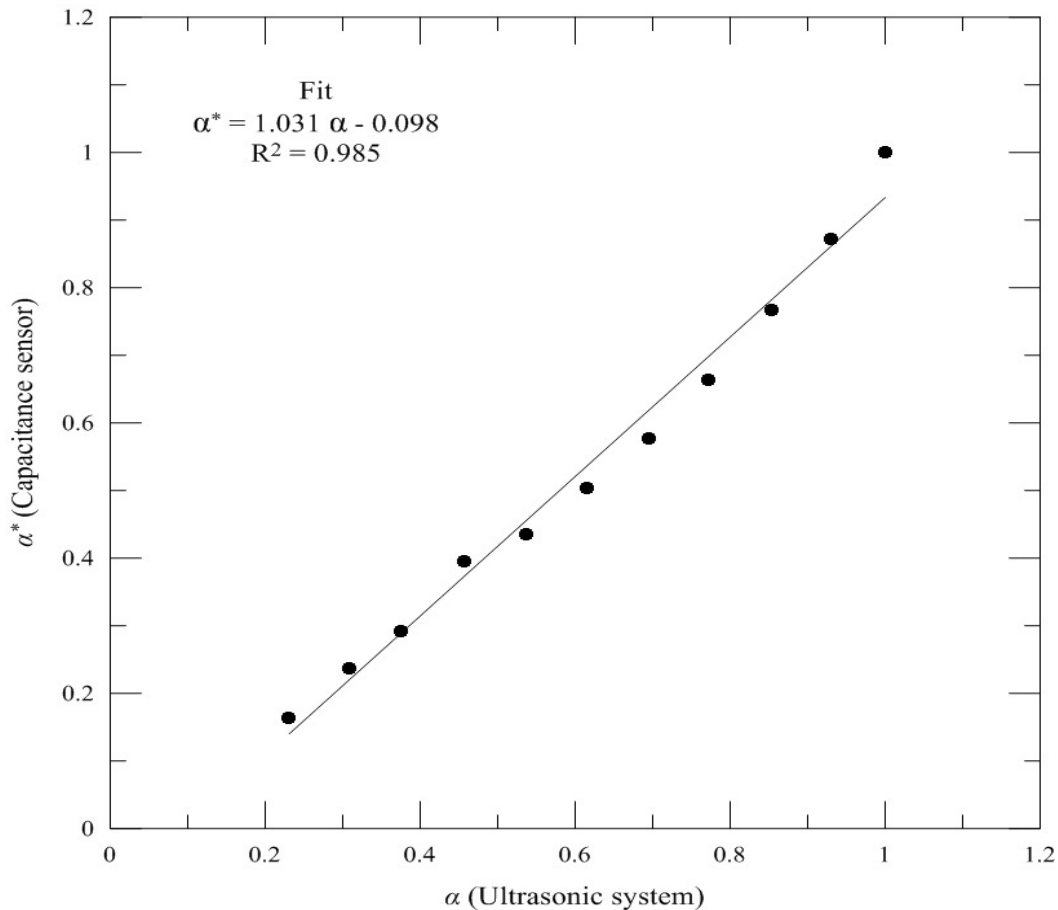

Figure 7: Comparison between void fraction results given by capacitance sensor, and ultrasonic system.

4. CONCLUSIONS

A simple capacitance sensor for two-phase void fraction measurements has been designed, and constructed. Preliminary tests have been carried out on a horizontal flow section installed in LTE/IEN. In this work the following conclusions were obtained:

- i) the capacitance sensor developed was suitable for measurements of void fraction related to a gas-liquid stratified horizontal test section.
- ii) a good linear relationship was obtained between the capacitance and the liquid volume inside the test section.
- iii) the results of void fraction measurements given by the capacitance and ultrasonic techniques showed a good agreement.
- iv) in case of metallic pipes, it is mandatory that the capacitance sensor must be electrically insulated of the pipe walls.

ACKNOWLEDGEMENTS

The authors thank to FAPERJ and CNPQ for financial support.

REFERENCES

1. G. F. Hewitt, I. King, P. C. Lovegrove, "Holdup and pressure drop measurements in the two-phase annular flow of air-water mixtures", *British Chemical Engineering*, **Volume 8**, pp. 311 - 318 (1963).
2. H. S. Isbin, H. A. Rodriguez, H. C. Larson, B. D. Pattie, "Void fractions in two-phase flow", *AIChE Journal*, **Volume 5**, pp. 427-432 (1959).
3. Y. Y. Hsu, F. F. Simon, and R. W. Graham, "Application of hot-wire anemometry for two-phase flow measurements such as void-fraction and slip velocity," *Multi-phase Flow Symposium*, Nov 17-22, ASME, N. J. Lipstein, Ed., pp. 26 – 33 (1963).
4. G. A. Gregory, L. Mattar, "An in-situ volume fraction sensor for two-phase flows of non-electrolytes", *Journal of Canadian Petroleum Technology*, **Volume 12**, pp. 48-52 (1973).
5. M. Merilo, R. L. Dechene, W. M. Cichowlas, "Void Fraction measurement with a rotating electric field conductance gauge", *Journal of Heat Transfer*, **Volume 99**, pp. 330-332 (1977).
6. J. S. Chang, E. C. Morala, "Determination of two-phase interfacial area by an ultrasonic technique", *Nuclear Engineering and Design*, **Volume 122**, pp. 143–156 (1990).
7. L. G. Neal, S. G. Bankoff, "A high resolution resistivity probe for determination of local void properties in gas liquid flow", *AIChE J.*, **Volume 9**, pp. 490-494 (1963).
8. L. Cimorelli, R. Evangelisti, "Capacitance method for void fraction measurement in bulk boiling conditions", *International Journal of Heat Mass Transfer*, **Volume 10**, p. 277-288 (1967).
9. H. Bouman, C.M.J. Van Kuppen, and L.J. Raas, "Some investigations on the influence of the heat flux on flow patterns in vertical boiler tubes", *European Two-Phase Flow Group Meeting*, Harwell, Paper A2, June (1974).
10. H. A. Wael, "Capacitance sensors for void-fraction measurements and flow-pattern identification in air–oil two-phase flow", *IEEE Sensors Journal*, **Volume 6**, pp. 1153-1163 (2006).
11. L. Stott, R. G. Green, and K. Seraji, "Comparison of the use of internal and external electrodes for the measurement of the capacitance and conductance of fluids in pipes", *J. Phys. E: Scientific Instrumentation*, **Volume 18**, no. 7, pp. 539-587 (1985).
12. J. J. M. Garaets, and J. C. Borst, "A capacitance sensor for two-phase void fraction measurement and flow pattern identification", *Int. J. Multiphase Flow*, **Volume 14**, pp. 305-320 (1988).
13. D. C. Lowe and K. S. Rezkallah, "A capacitance sensor for the characterization of microgravity two-phase liquid-gas flows", *Measurement Science Technology*, **Volume 10**, no.10 (1999).
14. K. J. Elkow, and K. S. Rezkallah, "Void fraction measurement in gas-liquid flow using capacitance sensor", *Measurement. Science Technology*, **Volume 7**, pp. 1153-1163 (1996).
15. M. T. Shu, C. B. Weinberger, Y. H. Lee, "A simple capacitance sensor for void fraction measurement in two-phase flow", *Industrial and Engineering Chemistry Fundamentals*, **Volume 21**, pp. 175–181 (1982).
16. P. Cutler, *Análise de Circuitos CA*, McGraw Hill do Brasil (1976).

17. J. Lubbers, R. Graaff, "A simple and accurate formula for the sound velocity in water", *Ultrasound in Med. & Bio*, **Volume 24**, pp.1065-1068 (1998).
18. J. Chang, Y. Ichikawa, e G. Irons, "Flow Regime Characterization and Liquid Film Thickness Measurement in Horizontal Gas-Liquid Two-Phase Flow by an Ultrasonic Method", *Measurements in Polyphase Flow*, T.R. Heidrick and B.R. Patel eds., pp. 7-12 (1982).