

**Learning to drive with Advanced Driver Assistance Systems.
Empirical studies of an online tutor and a personalised warning display
on the effects of learnability and the acquisition of skill.**

D i s s e r t a t i o n

zur Erlangung des akademischen Grades

doctor philosophiae (Dr. phil.)

vorgelegt der Philosophischen Fakultät der

Technischen Universität Chemnitz

von Herrn Julien H. Simon, geboren am 19.09.1976 in Guérande, Frankreich

München, den 02. April 2005

ACKNOWLEDGEMENT

This work was carried out during my stay in the Department of Human Machine Interaction and User Research of the BMW Group in Munich. It was effectuate in collaboration with the Institute of Psychology of the Chemnitz University of Technology.

I would like to take this opportunity to thank everyone who has made this work possible.

In particular, I thank Professor Dr. Josef Krems for his invaluable advice, support and the close interest in my work.

For the supervision at BMW, I would like to thank Dr. Mathias Kopf. I am also particularly grateful to Dr. Klaus-Josef Bengler, who's advice and valuable comments significantly contributed to the work. I would also like to express gratitude to Dr. Alexander Huesmann and to all the colleagues from the simulator department at the BMW Group for the close collaboration and their work in implementing the traffic world and the cockpit set-ups used in the experiments.

Further, I would like to thank Hans Gerisch and all the interns and student trainees who contributed to the success of this work.

Last but by no means least, I would like to thank my family, friends and partner for their enthusiasm and unrelenting encouragement.

To my Grandfather

Table of contents

1	Driving with Advanced Driver Assistance Systems.....	9
1.1	Introduction	9
1.2	Objective and methods	11
2	Attributes of the human-machine system “driver–ADAS–environment”	12
2.1	Introduction	12
2.2	The Driver	13
2.2.1	Information processing	13
2.2.2	Skill acquisition.....	13
2.2.3	Hierarchical model of the driving task	15
2.2.4	Analysis of the driving task during assisted driving	17
2.3	Advanced Driver Assistance Systems.....	18
2.3.1	Differentiation of Driver Information and Assistance Systems.....	18
2.3.2	Classification of ADAS	19
2.3.3	Longitudinal control	22
2.4	The Environment	28
2.4.1	Classification of driving situations.....	28
2.4.2	Environmental influences on driving with ACC.....	29
3	Learning to drive with ADAS	32
3.1	Automation vs. assistance	32
3.2	Usability criteria for ADAS.....	36
3.3	Learnability.....	39
3.3.1	Critical aspects	40
3.3.2	Success criteria.....	43
3.3.3	Types of errors committed.....	45
3.3.4	Integration of driving with ADAS into normal driving behaviour	47
3.4	Methodological concepts to improve learning to drive with ADAS	50
3.4.1	Design principles.....	50
3.4.2	Proposed concepts	56
3.5	Conclusions and central hypotheses in the thesis	60
4	Methodologies for evaluation of ADAS	65
4.1	Field studies.....	65
4.2	Driving simulator	65
4.2.1	Simulator validation issues	68
4.3	Subjective measures	71
5	Explorative study	73
5.1	Field study – Long-term ACC system usage.....	73

5.1.1	Introduction.....	73
5.1.2	Methodology	75
5.1.2.1	Scope of the study	75
5.1.2.2	Participants.....	75
5.1.2.4	Apparatus.....	76
5.1.2.5	Procedure	80
5.1.3	Results	81
5.1.3.1	Usage of system functionality.....	82
5.1.3.2	Operation of the system.....	85
5.1.3.3	Occurrences and reactions to system limits.....	89
5.1.3.4	Range of application.....	94
5.1.3.5	Subjective evaluations	99
5.1.4	Discussion.....	103
6	Experimental studies.....	106
6.1	Driving Simulator – Learn-adaptive online tutor system.....	106
6.1.1	Introduction.....	106
6.1.2	Methodology	118
6.1.2.1	Design.....	118
6.1.2.2	Participants.....	123
6.1.2.3	Apparatus.....	124
6.1.2.4	Procedure	125
6.1.3	Results	132
6.1.3.1	Usage of the tutor system	132
6.1.3.2	Acceptance of the tutor system	137
6.1.3.3	Efficiency of the tutor system	141
6.1.4	Discussion.....	157
6.2	Driving Simulator – Personalised ACC multi-level warning system.....	167
6.2.1	Introduction.....	167
6.2.2	Methodology	175
6.2.2.1	Design.....	175
6.2.2.2	Participants.....	181
6.2.2.3	Apparatus.....	182
6.2.2.4	Procedure	183
6.2.3	Results	187
6.2.4	Discussion.....	209
7	Conclusion.....	221
7.1	Comments on the evaluation methods	225
7.1.1	Field study.....	225

7.1.2	Driving simulator	226
7.2	Implications and recommendations for the design of ADAS.....	227
7.3	Further research and outlook	230
8	References	232
9	Appendix.....	249
9.1	Appendix A. Interview and questionnaire in the long-term field study.....	249
9.2	Appendix B. Instructions and questionnaire in the tutor system study.....	255
9.3	Appendix C. Situation detection conditions in the tutor system study	259
9.4	Appendix D. Instructions and questionnaire in the warning system study	263

List of Figures

Figure 1. The joint influence of ADAS functionalities and capabilities, environmental factors and driver characteristics on informational requirements and design characteristics.	12
Figure 2. ADAS Roadmap.....	20
Figure 3. The basic ACC modes	22
Figure 4. Speed-dependent ACC deceleration.....	24
Figure 5. Taxonomy of adaptation approaches for an ACC system	59
Figure 6. Five series mock-up in BMW driving simulator.....	66
Figure 7. Set-up of the BMW driving simulator.....	67
Figure 8. Functions in the Multi-Function Steering wheel (MFS).....	76
Figure 9. ACC displays in the increments of the speedometer.....	77
Figure 10. Structure of the overall hardware set-up in car	78
Figure 11. Example of the recorded video scenery	79
Figure 12. Scenery and driver cameras	80
Figure 13. Total absolute times the ACC was switched on, on the highway	83
Figure 14. Average amount of times the ACC was switched on per kilometre.....	84
Figure 15. System activation for all drivers.....	86
Figure 16. System de-activation for all drivers.....	88
Figure 17. Use of I/O to de-activate the system.....	89
Figure 18. De-activating the system with a moderate braking force ($<-1,5\text{m/s}^2$).....	89
Figure 19 Categories of take-over situations in which hard or panic braking was executed ...	91
Figure 20. Panic braking analysis of immediate interventions in take-over situations.....	92
Figure 21. Panic braking analysis of delayed interventions in take-over situations	92
Figure 22. Absolute number of changes in desired headway	95
Figure 23. Setting of the selected distance dependent on the traffic quality and the type of road for the first quarter of total driven kilometres for driver 3.....	96
Figure 24. Setting of the selected distance dependent on the traffic quality and the type of road for the third quarter of total driven kilometres for driver 3.....	97
Figure 25. Setting of the selected distance dependent on the traffic quality and the type of road for the fourth quarter of total driven kilometres for driver 4	97
Figure 26 Structure of the embedded tutor module.....	109
Figure 27 Information symbol of the tutor system.....	122
Figure 28. Implemented card reader in driving simulator cockpit and ACC buttons in MFS125	
Figure 29. The three motorway segments of the A9 course to the north of Munich	127
Figure 30. Programmed traffic situation sequence in drive 1	128
Figure 31. Programmed traffic situation sequence in drive 2.....	129
Figure 32. Programmed traffic situation sequence in drive 3.....	131

Figure 33. Mean number of speech outputs issued in the ‘functional principle’ help category	133
Figure 34. Mean number of speech outputs issued in the ‘system operation’ help category	133
Figure 35. Mean number of speech outputs issued in the ‘system limits’ help category	134
Figure 36. Number of times speech outputs were heard before being discarded for each driver in each drive	136
Figure 37. Percentage discarded acoustic feedback outputs issued to drivers	137
Figure 38. Drivers level of trust in the ACC system	138
Figure 39. Drivers perception of the tutor’s system helpfulness	139
Figure 40. Driver’s perception of the meaningfulness of the tutor system’s feedback	139
Figure 41. Drivers perceived importance of the system during the learning phase	139
Figure 42. Effects of the tutor system on drivers’ perceptions of traffic safety	140
Figure 43. Drivers perceived understanding of the system	141
Figure 44. Drivers understanding of the need for intervention	142
Figure 45. Frequency of panic braking per drive, averaged for both experimental groups	143
Figure 46. Absolute number of situations in which the lead vehicle decelerated below a speed of 30km/h	145
Figure 47. Absolute number of panic braking during a deceleration of the lead vehicle below a speed of 30km/h	145
Figure 48. Absolute number of driver intervention in critical and non-critical curves for both experimental groups in each drive	147
Figure 49. Absolute number of interventions during approach situations in drive 1	148
Figure 50. Absolute number of interventions during approach situations in drive 2	149
Figure 51. Absolute number of interventions during approach situations in drive 3	149
Figure 52. Number of interventions during ‘lead vehicle braking’ situations in drive 3	151
Figure 53. Number of interventions during ‘lead vehicle braking’ situations in drive 2	151
Figure 54. Number of interventions during ‘lead vehicle braking’ situations in drive 3	152
Figure 55. Usage of the system in adverse conditions (i.e. fog)	152
Figure 56. Absolute number of operational errors committed per experimental group	154
Figure 57. Percentage number of operational errors for each experimental group per drive	155
Figure 58. Drivers explicit knowledge of the ACC system	156
Figure 59. Basic structure of the ACC warning system	169
Figure 60. Parameters for the calculation of time reserve	172
Figure 61. Visual warning display in speedometer	178
Figure 62. Peripheral Detection Task (PDT) Stimulus	183
Figure 63. TTC at intervention during approach to lead car scenario at $v_{diff}=60\text{km/h}$	188
Figure 64. TTC at intervention during braking lead vehicle scenario at level $m/s^2 = -3$	189
Figure 65. Distance at intervention during approach to lead vehicle with $v_{diff} = 60\text{km/h}$	190

Figure 66. Distance at intervention during braking lead vehicle scenario at level $m/s^2 = -3$.	191
Figure 67. Minimum TTC during approach to lead vehicle with $v_diff = 60km/h$	192
Figure 68 Minimum TTC during braking lead vehicle scenario at level $m/s^2 = -3$	193
Figure 69. Distribution of min TTC in the enhanced condition, in drive 3.....	194
Figure 70. Reaction times during braking lead vehicle scenario at level $m/s^2 = -3$	195
Figure 71. Reaction times during braking lead vehicle scenario at level $m/s^2 = -4.5$	196
Figure 72. Maximum deceleration during approach to lead vehicle with $v_diff = 40km/h$...	197
Figure 73. Maximum deceleration during braking lead vehicle scenario at level $m/s^2 = -3.0$	198
Figure 74. Intervention categories during approach to lead vehicle with $v_diff = 40km/h$...	199
Figure 75. Intervention categories during braking lead vehicle with $m/s^2 = -1.5$	199
Figure 76. Intervention categories during braking lead vehicle with $m/s^2 = -3.0$	200
Figure 77. Number of panic braking situations for every level of each scenario	201
Figure 78. Mean decelerations of panic braking for every level of each scenario.....	202
Figure 79 Standard deviation of road edge distance in both conditions and manual driving.	203
Figure 80. Percentage hit rate to the onset and recovery stimuli	204
Figure 81. Incorrect reactions to the left PDT stimuli.....	205
Figure 82. Mean reaction times to the onset and recovery stimuli	205
Figure 83. Comparison of mean reaction times to onset and recovery stimuli for each drive	206
Figure 84 Participants' subjective ability to predict the need for intervention.....	207
Figure 85. Participants' subjective ability to predict the necessary braking force upon intervention.....	207
Figure 86. Participants' subjective impressions of the display's help in keeping a safe distance	208
Figure 87 Participants' subjective impressions of the display's help to avoid a collision	208

List of Tables

Table 1. Relation between task levels and behavioural levels.....	17
Table 2. Characteristics of the longitudinal driving task.....	28
Table 3. Summary of the comparison between field and simulator experimental methods.....	70
Table 4. List of variables measured in the long-term study	78
Table 5. Statistical overview of the main study parameters	81
Table 6. Absolute frequency table of decelerations smaller than $-1,5\text{m/s}^2$	89
Table 7. Types of system limits in which intervention is (sometimes) necessary.	90
Table 8. Coding used for the different levels of road types.....	95
Table 9. Automatically detected situations and corresponding speech samples, categorised into four help categories.....	110
Table 10. Detected situations in dynamic conditions.....	113
Table 11. Levels of the independent variable 'scenario'	119
Table 12. List of dependent variables.....	123
Table 13. Outline of the study's procedure.....	126
Table 14. Description of traffic situations programmed in experimental drive 1.....	128
Table 15. Description of traffic situations programmed in experimental drive 2.....	129
Table 16. Description of traffic situations programmed in experimental drive 3.....	131
Table 17. Absolute number of curve situations experienced per participant	146
Table 18. The four outcomes of signal detection theory	147
Table 19. Absolute number of approach situations experienced per participant.....	148
Table 20. Absolute number of braking lead vehicle situations experienced per participant..	151
Table 21 Total number of crashes in both groups over the entire experiment	155
Table 22. Test questions of the ACC system's operation and system limits.....	156
Table 23. Warning outputs/ MMI information	170
Table 24. Levels for the independent variable 'scenario'	176
Table 25. ACC Symbols for Standard Display	177
Table 26. ACC Symbols for Enhanced Display	179
Table 27. List of dependent variables.....	180
Table 28. Study outline.....	185
Table 29. Total number of crashes in both groups in the entire experiment	202
Table 30. Number of lane departures per drive in each group.....	202

ABSTRACT

Beside all the technical challenges concerning sensor quality and control algorithms one of the main issues related to the introduction of advanced driver assistance systems (ADAS) constitutes the human-machine interaction. This covers not only the physical interface between the driver and the system but also the understanding and cognitive model the driver needs to operate the system.

The explorative analysis of a long-term field study of the use of ACC, was aimed at identifying characteristics of the learning process and their potential implications for conceptualising novel displays to increase, particularly in the early phases, usability and safety of the system through the adaptation of information to the drivers. The analysis of the learning aspects derived from drivers' interaction with the system enabled the identification of learning aims for the usage of an ACC system and an objective classification of observable behaviours from which different levels of skill can be interpreted. It was concluded that by responding to the difficulties met by users in the actual situation and by adapting the information to the drivers' experience, drivers' learning progress could be accelerated through better comprehensibility and predictability of the system.

To this aim, two innovative help-systems were conceived, implemented and evaluated in terms of drivers driving behaviour and interactions with the ACC system, in the BMW fixed-base driving simulator.

A learn-adaptive, multi-modal, on-line tutor system that covered interactions with the system at every level of the driving task (Reichart, 2001) for which learning must be effectuated, was tested with 11 participants. A personalised learning model of the driver was used to relate the drivers' prior usage of the system and his situational experience, to give the driver additional advice and explanation in order to shorten the learning period. A main effect was found between the experimental groups' understanding of the system and in participants' ability to predict when to reclaim control of the system, as measured by the reduction in unnecessary interventions and reduced number of panic reactions. The use of cognitive apprenticeship methods (Cognition and Technology Group at Vanderbilt, 1993) on an online adaptation of feedback showed a positive influence on the learning process, increasing the speed of the learning process towards the acquisition of skill.

The second experiment's objective was to develop an interface that most effectively helped drivers learn to predict the need to reclaim control and the appropriate sensitivity of response in take-over situations. Drivers interactions with a didactic, two-step warning display, based on a time algorithm that was personalised to drivers maximum preferred deceleration level, was tested with 24 participants. Display effects were observed in time-to-collision, reaction times, the number of false alarms (unnecessary driver interventions) and misses (collision or near collisions). Significant differences were also found in distance error, adequate

deceleration rates, panic braking and reaction times on the peripheral detection task. These results were also largely supported by the subjective measures.

The proposed concepts have shown methods of reducing the ADAS learning phase and accelerating drivers behaviour to a skill level. The theoretical and empirical work described in this thesis plays an important role in deriving recommendations for systems that reduce the amount of learning demand on the driver and eliminates learnability issues that can lead to safety-critical traffic situations.

1 DRIVING WITH ADVANCED DRIVER ASSISTANCE SYSTEMS

1.1 Introduction

In most of the developed world, the increase in transport and traffic over the past decades has placed a tremendous logistic problem and burden on society. The alarming growth rate of road transport and the explosion in personal mobility has negative repercussions on energy, emissions, traffic safety, road capacity (congestion) and of course, on the increased risk of death and injury. With regards to the latter, across the 15 EU member states there are 43 000 road deaths per year and an estimated 3.5 million casualties (ETSC, 2000). A look at today's accidentology reports in Germany, shows that frontal collision accounts for 9% of accidents, turning at an intersection for 28%, 9% involves accidents with pedestrians, 16% are situations in which the car left the road, and 25% are collisions into lead vehicles (Bundesamt, 2003).

Advanced Driver Assistance Systems (ADAS) are regarded as a promising tool to improve traffic safety, driver comfort, as well as increase road capacity, traffic flow and limit energy consumption. Driver assistance systems are defined as systems in which the driving task is partly or entirely taken over by an automated system.

The first generation of ADAS introduced into the market, is the Active Cruise Control (ACC) system. This system replaces the speed adaptation and distance-keeping task of the driver with respect to the lead vehicle in the same lane. The ACC system can be seen as the backbone of a host of new support technologies that will in the near and further future ensue. The structure of these future systems will, however, be kept the same as that of the ACC system. The system works as a parallel co-pilot, which is designed to act in a similar manner to a human driver during a specific driving task. The driver gets processed information from the co-pilot, which consists of sensors for recognition of driver and vehicle behaviour and the driving environment with the road and possible objects on it (Bachmann et al., 2000).

In traditional cruise control, the system relieves the driver of foot control of the accelerator only i.e. relieving the driver of some physical workload, whereas ACC relieves the driver of some of the decision making elements of the task, such as deciding to brake or change lanes i.e. relieving the driver of some mental workload, as well as physical demands of accelerator control. Potentially, then, ACC is a welcome additional vehicle system that will add comfort and convenience to the driver. Indeed, the automation of driving tasks could potentially improve driver comfort by facilitating the driver's tasks and decreasing the amount of necessary actions. It could also potentially improve traffic safety by reducing the severity or

incidence of certain types of collisions by assisting drivers in the difficult perceptual task of correctly estimating the relative speed and distance to other road users. Further, by establishing a harmonisation of the traffic flow, it could also potentially increase road capacity or limit energy use (Hochstadter et al., 1999). However, the introduction of automation into the automobile poses a wealth of cognitive and human factors concerns that are new to the driving domain.

Besides the known automation pitfalls regarding the quality of the interaction or the loss of psychomotor/ cognitive skills required for traffic situations, sensors and systems which fulfil the necessary requirements for a full automation of the driving task i.e. reliability, safety and dependability are not available (and will not be available in the near future). The problems stemming from this are numerous as the coverage of the actual sensors do not coincide with that of human sensory organs. If the limitations of sensor and signal processing are not made comprehensible to the driver, his understanding of the system will remain low and the development of a 'feeling' for the system will take considerable time. From an ergonomic viewpoint, in order to tackle the technology problems which lead to the string of unresolved HMI issues, the need for detailed knowledge concerning drivers learning behaviour as well as solutions towards designing driver assistance systems whose functionality, operation and system limits can be intuitively understood, is significant.

Further, the actual trend towards combining ADAS to reduce the burden on the driver increases the functionality of driver assistance systems and thus necessarily, their complexity. The more integrated functionality and sensors in the vehicle—with their specific limits—the more complicated the system is likely to become for the driver. The studies conducted hint to the fact that even rather simple assistance systems have to be learnt and that comprehension problems could produce critical traffic situations (Fancher et al., 1998; Kopf & Nirschl, 1997; Nilsson, 1995; Simon & Kopf, 2001; Stanton & Marsden, 1996; Weinberger, 2000). In particular, take-over situations are known to be critical and sometimes very demanding for the driver. Take-over situations are typically situations in which the ADAS reaches its limits forcing the driver to take over control, possibly within a very short space of time. The only means, as yet, to overcome these comprehension problems is by providing an increasingly complex and comprehensive user manual. However, firstly, such a complex system cannot be optimally represented in a manual and secondly, it is well known that the user manuals are not read by all users.

Driver assistance systems thus offer a considerable potential for improving driving safety and comfort. In designing systems to realise this potential successfully, however, important issues concerning the human-machine interaction arise and need to be considered.

1.2 Objective and methods

This work discusses various possibilities of supporting driver interactions with ADAS, based on ACC. The embedded support offers drivers visual and acoustic feedback dependent on the specific context as well as either their learning stage or on some feature of the driver which is assumed to be quite constant over time. Targeted engineering psychology methods were employed (Wickens & Hollands, 2000) for the various phases of the design process. The starting point of the analysis was the human-machine interaction between drivers and ADAS. Based upon this analysis, the necessary information was derived and the design for an optimal presentation of information through intelligent help-systems were postulated and finally tested and evaluated.

The aim of this procedure was to improve drivers' interactions with ADAS through better understanding of the system's functionality, operation and ability to predict its limitations and the consequences thereof.

Within the framework of this study, the data from an exploratory field study was used to uncover aspects related to the operation of the system, the use in varying environmental conditions and behavioural reactions and adaptations to system limits. The analysis identified characteristics of drivers' approach and learning processes and of the competence possessed after extended usage, compared to initial usage and their implications for approaches towards intelligent support systems. The driving simulator was used as experimental method to evaluate the designs of the intelligent support system concepts on driving behaviour and interactions with the system.

In order to analyse the interactions between the driver, the system and the environment, it was necessary to assess each aspect individually first. In chapter two, each part of the system is analysed as well as the resulting interactions between the parts of the whole. Chapter three describes the theoretical background in the area of learning technical systems and explains the methodological differences of the proposed concepts. Chapter four describes the different research methods and instruments that were used. The methods employed are discussed in terms of reliability and validation issues as well as their appropriateness to answer the research questions. Chapter five describes the results of three studies. Firstly, the data of a long-term ACC study is evaluated with respect to learning behaviour. The learning goals are defined and the most important learning hurdles are extracted. Secondly, a multi-modal, learn-adaptive, situation-specific tutor system is specified. Its implementation is described as well as its experimental evaluation in the driving simulator. Thirdly, a two-level personalised warning concept is proposed and experimentally evaluated. Chapter six summarises the results, gives a critical overview of the employed methods and proposes recommendations for more intuitive learn-adaptive systems and future research.

2 ATTRIBUTES OF THE HUMAN-MACHINE SYSTEM “DRIVER–ADAS–ENVIRONMENT”

2.1 Introduction

Driver cognitive characteristics imply constraints on what information drivers require and how that information can be best displayed. Thus, the cognitive characteristics of drivers help to define information requirements and formats for display and control. Although cognitive characteristics help to define design requirements, they are not the only factors involved. Driver behaviour and information needs may also be understood by a close examination of driver tasks and by a functional description of the driver’s interaction with ADAS. In other words, multiple factors such as the functional capabilities of the driver assistance system, environmental factors and driver characteristics provide the context for driver interaction with driver assistance systems and play an important role in determining information that should be presented to drivers. Figure 1 shows the interrelation between the driver, ADAS and the environment. The design of the information pertinent to drivers using driver assistance systems depends on considering each of these elements.

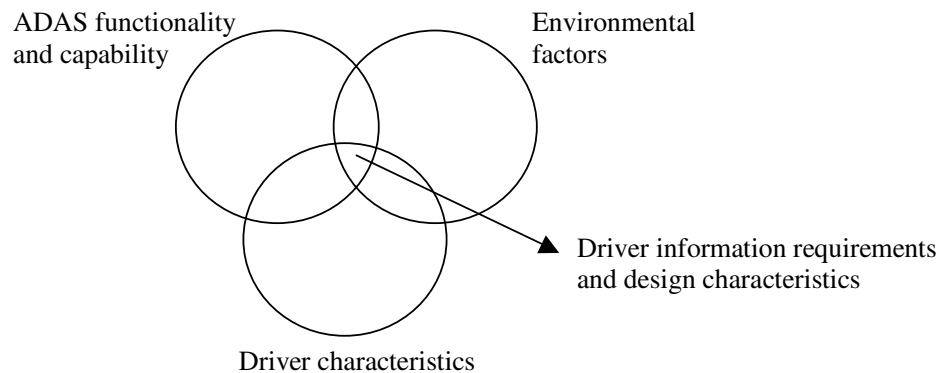

Figure 1. The joint influence of ADAS functionalities and capabilities, environmental factors and driver characteristics on informational requirements and design characteristics.

Driver behaviour and the associated informational design implications depend then on understanding both the context in which the driver operates and driver cognitive characteristics. This chapter examines each aspect of this interaction and their respective effects on drivers’ informational requirements. This review does not attempt to completely specify driver information requirements regarding driver assistance system or indeed their

design parameters, but simply draws upon the human factors and psychology literature to identify and describe cognitive constraints that may be particularly important in the design of support systems for ADAS.

2.2 The Driver

2.2.1 Information processing

In models of information processing any task can be seen as the process of the processing of stimuli. This processing can be controlled or automatic, depending on the quantity and type of practice. Automatic processing is characterised as fast, effortless and parallel processing, which develops on the basis of extended consistent practice. It is contrasted with controlled processing, which refers to slow, serial and effortful processing (Wickens & Hollands, 2000). Early models of divided attention asserted that humans behave as a single channel with limited capacity for information processing and that they are unable to perform more than one thing at the same time. Tasks will interfere when they both need general attention. The degree to which these tasks interfere is dependent on the level of required control processing. The fact that humans are seemingly able to perform more tasks at the same time and thus divide their attention efficiently e.g. keeping course while changing gears and maybe even talking at the same time, was explained by covert attention switching between the tasks (Broadbent, 1982).

Multi-capacity theories argue that human information processing depends on separate resources and that humans can divide their attention efficiently between concurrent tasks in cases where the tasks draw on separate rather than common processing resources. The most influential of these multi-capacity theories is Wickens’ (1992) multiple-resource theory. It states that tasks can be executed concurrently when they utilise different modalities of input e.g. visual versus auditory, and response (manual versus vocal), when they differ in the demands on certain stages of processing (perceptual, central or motor processes), and when they require different codes of perceptual and central processing (spatial versus verbal codes). The multiple resource theory predicts more interference between tasks if both tasks demand spatial processes or if both tasks demand verbal processing across any stage.

2.2.2 Skill acquisition

Developed skills used in driving or operating complex systems arise as a result of a complex series of behaviour patterns learned over long periods. In developing these skills, feedback, both from the sense organs and in terms of knowledge of results, plays an extremely important role. One of the basic requirements for learning an action or a skill rests in

reinforcing, by feedback, the consequences of the response to a particular stimulus. Two main principles apply in determining the strength of a conditioned response. First, positive reinforcement is more effective than negative reinforcement and secondly, the more frequently the action is reinforced (either positively or negatively) the greater the learning effect will be (Osborne, 1995; Schroth, 1997).

In cognitive psychology, the most widely accepted account of the acquisition of skill was the theory developed by Fitts & Posner (1967) that stressed three stages: a ‘cognitive’, ‘associative’ and an ‘autonomous’ stage. More recently, Anderson (1993) referred to very similar stages: a ‘declarative’, a ‘knowledge compilation’ and a ‘procedural’ stage for which he distinguished among three types of memory structures: declarative, procedural and working memory. Declarative memory takes the form of a semantic net, linking propositions, images and sequences by associations. Procedural memory (also long-term) represents information in the form of ‘productions’, where each ‘production’ has a set of conditions and actions based in declarative memory. Working memory is the part of the long-term memory in which activation takes place.

Both approaches see the initial stage, as heavily dependent on expressible or expressed verbal accounts of what is required. Performance is relatively unstable as possible strategies are tested and discarded and easily interfered with where distractions are present. The second stage differs considerably in the language used to describe them but the common characteristic is that verbal mediation of performance is much reduced and that associations strengthen between eliciting conditions and the actions they require. Performance is still subject to disruption or through distraction or considerations of alternative sources of action but is faster and more reliable. The final stage is ‘automatic’, in the sense that verbal mediation of performance, even accurate verbal description of performance, is no longer required or possible. It is also effortless and highly consistent. Although the original Fitts and Posner framework has been widely applied in the last four decades, Anderson’s framework has been the basis for intelligent tutors (Anderson et al., 1995; Cognition and Technology Group at Vanderbilt, 1993) and will thus be given closer consideration here.

In Anderson’s revised Atomic Components of Thought Theory (ACT-R) (Anderson, 1993), skilled behaviour is seen as procedural in nature and assumes that the procedures used are derived from declarative or factual knowledge of a domain. Declarative knowledge is a semantic network of facts about items within a domain, which an individual learns when he or she encounters a new domain. In order to perform tasks within this domain, the learner must use this knowledge together with general problem solving strategies. The condition-action rules or ‘productions’ are formed on the basis of the applications of these general strategies to domain-specific knowledge. The same declarative knowledge and the same general strategies, applied to different circumstances will result in different productions being formed, which

support the different uses of the same knowledge. The derivation of such productions through association of declarative knowledge and general problem solving strategy is the main purpose of the Knowledge Compilation stage. Once formed, procedures are triggered and thoughts or action result. The outcome of repeated use of the same production is proceduralisation. ACT supports three fundamental types of learning: generalization, in which productions become broader in their range of application, discrimination, in which productions become narrow in their range of application, and strengthening, in which some productions are applied more often. Anderson’s (1993) view assumes that the repeated use of particular productions serves to strengthen that production, the strengthening being reflected in the rapidity with which the production’s eliciting conditions are detected and the ease i.e. consistency and speed, with which the production is implemented.

Some training conditions are effective in providing an immediate, short-term benefit to performance. In learning a new procedure, for example, guidance conditions can be arranged that are specifically designed to minimise the amount of error that can occur while practicing a task. However, even though performance may be enhanced while the guidance training condition is in effect, this temporary boost often fails to satisfy the overall training goal, which is to influence learning of the skills. By definition, learning involves the relatively permanent change in the capability to perform a skill (Schmidt & Lee, 1999). Assessments of learning during the time when a guidance training condition is being implemented can be misleading because of the temporary elevation in performance that is provided by these conditions. An important aspect for the assessment of learning is to evaluate retention or transfer of the skills following a period in which the skills have not been specifically practiced and where the training conditions are no longer providing a temporary benefit to performance.

Evidence for a number of situations in which learning can occur in the absence of observable physical improvements in performance e.g. in mental practice and observation, or where performance during practice completely misrepresents how learning is proceeding e.g. variable versus constant training conditions or random versus blocked training conditions, form instances when feelings about the effectiveness and efficiency of a training condition may be an illusion if based on subjective evaluations or short-term changes in performance (Bjork, 1998). Thus, it is important to be aware of the distinction between performance and learning, as illusions of competence in learning can be potentially dangerous if performance improvements vanish quickly or do not transfer well beyond the training regime.

2.2.3 Hierarchical model of the driving task

The driving task can occur at different levels of performance control. The more the driving task occurs in an automated fashion, the less attention it will demand. The degree to which levels of demands on attention differ, is dependent on the type (regulation level) of

performance control. Rasmussen (1987) distinguished three levels of control of task performance. These are the knowledge-based level, the rule-based level and the skill-based level. This general hierarchical classification can be used as an instrument to investigate a complex task like driving. The different levels of human performance show how much attention is needed to perform tasks.

At the highest knowledge-based level, human behaviour is goal-controlled and depends upon feedback correction i.e. closed-loop process. This is the level at which people develop new ways of problem solving. It requires attention and effort. To be useful for reasoning and computation, information from the environment must be perceived as symbols. Symbols are defined by and refer to the internal conceptual representation that is the basis for reasoning and planning.

When the task or environment becomes more familiar, human behaviour is not goal-controlled anymore but orientated towards the goal and controlled by a set of rules that have proven successful previously. At this rule-based level, courses of actions (rules) are available and an appropriate action has to be chosen. The process of choosing a rule may be more or less conscious, but once a rule is chosen the actions are carried out automatically; so less attention is required compared with the knowledge-based level. Derivations trigger rule adjustment or goal adjustment. The control process at this level of task performance is mostly closed-loop and information from the environment is perceived as signs. Signs serve to activate or modify predetermined actions or manipulations and refer to actual situations or proper behaviour.

At the lowest skill-based level, highly practised routines are carried out and actions are completely automated. This means that actions are not continuously monitored and therefore that there is no continuous feedback mechanism in this open loop control mode. The information from the environment is perceived as signals, which have no meaning. Only something going wrong in this open-loop mode triggers task performance to be carried out at a higher level.

The distinction between signals, signs and symbols is not dependent on the form in which the information is presented but rather on the context in which it is perceived, i.e. upon the intentions and expectations of the perceiver (Rasmussen, 1983). Rasmussen’s taxonomy does not account for the dynamic relations between the different type of processing, however, as described in a subsequent section, Reason (1992) integrated processing mechanisms with Rasmussen’s model.

Michon (1985) proposed a hierarchical structure of the driving task in which driving behaviour is modelled in a hierarchy of three types of tasks. These tasks were classified into the strategic, tactical and operational levels. At the strategical level, drivers prepare their journey, it defines the general planning stage of a trip, including the determination of trip goals, route, modal choice i.e. mode of transportation, trip time and speed. Considerations

about costs and risks play an important role here. Decisions are influenced, on the one hand by goals and attitudes and on the other hand, by the amount of information drivers have about general traffic conditions and their own state.

At the tactical level, drivers exercise manoeuvring control, allowing them to negotiate the directly prevailing circumstances e.g. obstacle avoidance, gap acceptance, turning and overtaking. Here drivers are primarily concerned with interacting with other road users and the road system. This manoeuvring behaviour is mostly dictated by the current situation but also by the goals set at the navigation level.

The operational level involves the elementary tasks that have to be performed to enable manoeuvring the vehicle. It involves the control of the vehicle by using car controls and pedals, the steering wheel etc. Most of these elementary operation tasks are performed automatically and unconsciously, like changing gears.

The control hierarchy of driving has been related to Rasmussen’s taxonomy, as shown in Table 1, adapted from Reichart (2001). For experienced drivers, most driving tasks cluster in the three cells on the diagonal that runs from the upper left to the lower right box. Knowledge-based behaviour is involved at the strategical level, rule-based behaviour at the tactical level, and skill-based behaviour at the operational level. As shown by the examples in other matrix cells, exceptions reflect differences between skilled and novice performance and between familiar and unfamiliar situations. For example, novice drivers initially use knowledge-based behaviour to shift gears, while experienced drivers use skill-behaviour.

Table 1. *Relation between task levels and behavioural levels*

	Strategical tasks	Manoeuvring tasks	Operational tasks
Knowledge-based	Navigating in unfamiliar area	Controlling skidding car	Novice on first lesson
Rule-based	Choice between familiar routes	Passing other vehicles	Driving unfamiliar vehicle
Skill-based	Route used for daily commute	Negotiating familiar intersection	Vehicle handling in curves

2.2.4 Analysis of the driving task during assisted driving

Assistance systems can be defined as systems that take-over a part of the driving task. In the hierarchical framework of driver behaviour, the introduction of ADAS does not significantly alter the above-described structures, it merely introduces an additional component to the mental model associated with the task that the system is capable of supporting or performing.

Several interesting issues arise with the introduction of a system that is capable of vehicle control under a limited set of conditions. ADAS support but do not take over fully, or under all conditions, a part of the driving task. They merely assist the driver in performing a particular task with less effort. The drivers retain responsibility and are expected to pay attention to traffic and to the road. ACC systems, for example, have limited sensing capabilities and are often not equipped with emergency braking. This requires the driver to identify these emergency braking situations and take precautionary action. The driver is thus confronted with the additional choice of using the automation or performing the task manually.

A mental model of ACC has to be initialised via instructions about its interface, its functionality and its operational limitations. Interaction, exposure and experience then shape the mental model of ACC through a feedback mechanism in which prediction errors are used to update the various components of the mental model. Some of the important issues in the adaptation process is the level of automation or the degree to which the driver is taken out of the control loop, the new role of the driver, the rate at which semi-critical events (the ones that ACC cannot handle) develop and the frequency with which these events tend to occur (Simon & Kopf, 2001). Ideally, the driver needs to take all these issues into account to arrive at the appropriate safety-conscious role division between driver and system. The next section describes changes in driving behaviour associated to the interaction with the ACC.

2.3 Advanced Driver Assistance Systems

Advanced Driver Assistance Systems are intelligent systems that support the driver in performing one or more elements of the driving task. This chapter outlines the systems that can be summarised under the term ADAS. It describes their expected effect in terms of traffic safety, road capacity and driver comfort. Due to the wide range of possible ADAS, from systems that maintain a proper speed or distance to a vehicle in front to fully automated driving, this chapter describes only those systems that are generally recognised as the first steps towards fully automated driving. Systems that only inform, the so-called Driver Information Systems (DIS) do not fall under the definition of Driver Assistance Systems (DAS). These systems and their implications will therefore be alluded to but not described in detail.

2.3.1 Differentiation of Driver Information and Assistance Systems

As a result of ongoing progress in electronics, a proliferation of technological devices in the last decades has been observed. The majority of these new functions inside the car are related to information, communication and entertainment systems (Niedermaier & Lang, 2001). In

addition to the board-computer and navigation systems, mobile telephones, dynamic routing and traffic-state-controlled navigation devices, internet services etc. also feature in the vehicle. As many studies have shown, visual Human Machine Interfaces (HMI) especially are likely to decrease drivers performance of the driving task (Jahn et al., 2002; Verwey, 1995; Vollrath & Totzke, 2000). Similarly to the use of ADAS, usability of these systems can be addressed through the learnability and through users mental models. The major difference is that the learning phase with these systems can be accomplished at standstill. The increase of telematics inside vehicles and the interaction ensuing from the use of these systems has highlighted the need for new legislative and design standards on the presentation of information to drivers. A wealth of standards, guidelines and norms for Driver Information Systems (DIS) exist, compared to Driver Assistance Systems (DAS). Standardisation of the presented information has also led to methodologies, often based on the large Human-Computer-Interaction (HCI) research field, for evaluating the learning process and defining acceptable performance levels. Although a suitable model is still missing that would describe learning of driver information systems in detail, investigations of learning processes and individual behaviour in the context of driver assistance systems demands considerably more effort compared to driver information systems (Bengler, 2004).

During driving, Driver Information Systems do not affect the driving task directly, however, these information and communication systems also need to be operated and thus compete for the driver’s attention. In certain situations, the danger of overburdening drivers or causing excessive distraction could arise. This danger can be reduced effectively by an appropriate design and interconnection of the advanced driver assistance and information sub-systems in the vehicle.

2.3.2 Classification of ADAS

Driver support systems can be classified with regards to the direction of the driving task that is supported or taken over by the system. Firstly, longitudinal support systems concern driving tasks in the forward direction of driving, such as speed and headway keeping. Secondly, lateral support systems concern driving tasks in the sideward direction like lane keeping and thirdly, integrated support concerns tasks in both forward and sideward directions. Driver support systems can further be classified in terms of their level of automation. Overrutable assisting driver support systems take over the driving task automatically but the driver can always take over vehicle control while the system is activated. Non-overrutable assisting driver support systems aim to replace (parts of) the driving task completely—most likely on dedicated lanes—and will decide whether the driver should take over (or a part of) the driving task again.

Although full vehicle automation may not be predicted before (or as early as!) 2030 (Walker et al., 2001), most researchers see an evolutionary path within these categorisations for the

development and introduction of driver support system. Such an evolution runs from the introduction of overrutable assisting support systems for the longitudinal driving task through to lateral control systems to the introduction of dedicated lanes and non-overrutable full automation of roads. An overview of the planned ADAS in future and their likely effect on safety enhancements are shown in Figure 2, adapted from Ehmanns (2002).

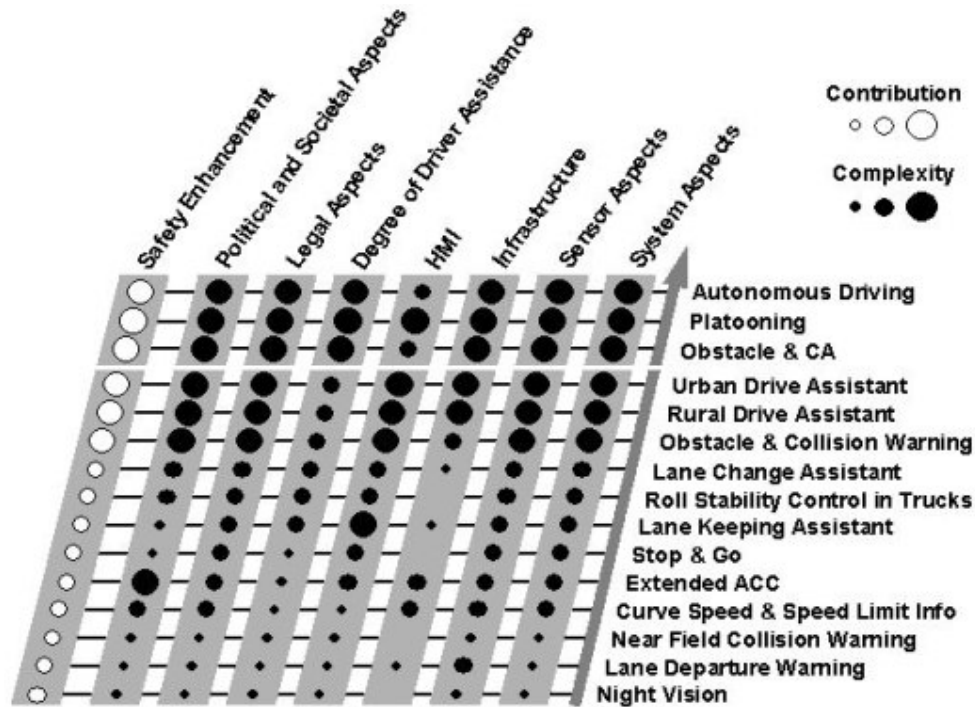

Figure 2. ADAS Roadmap

The graph shows that not only safety, technical and HMI issues are at stake but that central to the introduction of ADAS are also political, societal and legal aspects. Thus the complexity of each aspect alone cannot be considered when assessing the successfulness of ADAS in achieving increased safety on the road but must be viewed as the combination of these aspects (Becker et al., 1999; Kopf & Becker, 2000). The further ADAS moves away from informative systems and overrutable systems towards non-overrutable systems, each system becomes more complex and inevitably, so will the integration of any combination of these systems.

So far, predictions regarding the implementation of ADAS have held to be true as Adaptive Cruise Control (ACC)—an extension of a conventional cruise control system that does not only keep a fixed speed but adapts also, by means of a radar sensor, the distance to a preceding car—was the first of a series of Advanced Driver Assistance Systems, to be recently introduced to the market. Possibly the next system to be marketed will be a Stop & Go assistant, capable of handling the speed range between zero and about 40 km/h—currently not covered by the ACC system. Another ADAS likely to penetrate the market in the not too distant future is Heading Control which assists the driver in the lane-keeping task. By monitoring the

sidelines, the system can give a warning or actually correct the steering wheel position when the vehicle is about to cross this line. The systems operate on the principle of image processing to sense the roadside limits and are, therefore, largely dependent on road-side information. The course of the road must be sufficiently marked by e.g. lines, reflectors or radio-signals, depending on which type of lateral control system is used (Naab, 2000).

After lane-keeping systems, the next step is to support a driver during lane-change manoeuvres. The idea of the Lane Change Assistant (LCA) is to monitor the approaching traffic from behind and issue a warning if necessary. The requirements of the sensor technology required for LCA systems are particularly high as very large spatial areas need to be monitored i.e. lateral areas as well as near, medium and distant areas in the rear. In addition, the necessity to rule out any incorrect data is far greater than in the case of the comfort-oriented applications thus far available (Reichart, 2001). The implementation of the LCA in production vehicles requires, therefore, yet further technological progress in the field of sensor technology and driving environment interpretation.

Even further down the road are Collision Avoidance Systems (CAS). If ACC is a support system which assists the human being in his daily task by providing comfort, the Collision Avoidance System is an active safety system, which tries to prevent accidents whenever the situation becomes too critical. Front-to-rear end crashes involving two or more vehicles currently represent approximately one-fifth of all collisions. Driver inattention is believed to be the largest factor in these crashes (Dingus et al., 1997) and the next most important factor is ‘following too closely’ (Knipling et al., 1993). Collision Avoidance Systems have been proposed as a potential remedy to this type of accident (Ben-Yaakov et al., 2000; Goodrich & Boer, 2000; Hancock et al., 1996).

Contrary to the ACC system, all components including the sensing devices have to have failure tolerant design. Further, while ACC has to be supervised over the full time of operation, Collision Avoidance Systems work in the background. To avoid a collision, it overrides the driver and takes control of the lateral and longitudinal manoeuvring of the vehicle in order to fulfil the system aims. Taking the appropriate evasive action assumes knowledge and interpretation of a lot of different inputs from the on-coming traffic and / or traffic beside the subject vehicle.

Futuristic visions of intelligent vehicles, able to support drivers in complex driving tasks will indeed, require a new quality of vehicle sensors and appropriate signal processing techniques (Naab, 2004; Schwarz et al., 2002). One vision that has not yet been widely tested outside the realm of automated highway systems, is fully automated vehicles, on which the lateral and longitudinal control of vehicles is guided by the infrastructure instead of the driver (Huang & Chen, 2001; Kanaris et al., 2001).

Although the deployment of future forms of ADAS is uncertain, their realisation are seen to overcome many driver limitations in information processing and in offering a correct automated action dependent on the situation. Subsequently, the strive to find innovative ways of slashing the number of road accidents, partly through EU funded projects and partly within national funded projects, it is undoubtful that the number and complexity of ADAS is set to increase over the next few decades. It is to be expected that systems that have so far functioned independently of one another e.g. ACC and Heading Control, will be merged into a single overall system. Consequently, in the more distant future, several combinations of assistance for longitudinal and lateral control with varying degrees of automation are to be expected (Ehmanns et al., 2003; Freymann et al., 2002).

2.3.3 Longitudinal control

Active Cruise Control (ACC)

Although development of ACC goes back two decades, significant progress in both sensor and signal processing technologies has meant that ACC has been able to be successfully marketed world wide over the past few years. The main functional enhancement of ACC, compared to standard Cruise Control (CC), results from the ability of sensing forward traffic. See Figure 3, adapted from Prestl et al. (2000), for a description of the basic ACC function modes.

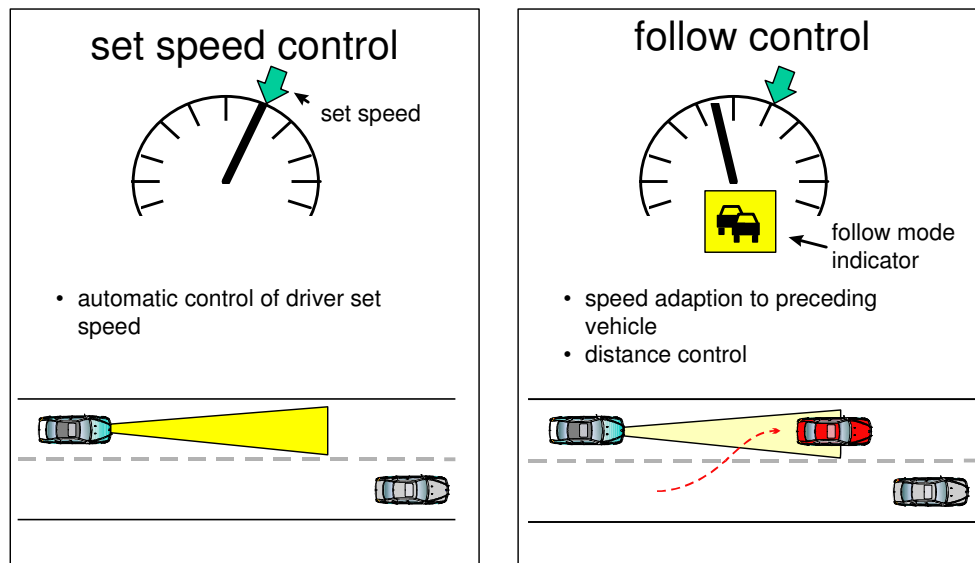

Figure 3. The basic ACC modes

The ACC function can be split into three major parts: the ACC controller that computes how the vehicle should accelerate, the longitudinal control which manages the actuator systems to

achieve the desired acceleration and the human-machine interface enabling the driver to operate, supervise and reclaim control when necessary.

The ACC controller

The task of the ACC controller is to select the relevant preceding vehicle. The expected course of the ACC equipped vehicle is determined using the speed and the course curvature i.e. the predicted future course of the ACC car. The radar sensor supplies the distance, relative speed and angle of multiple objects representing different preceding vehicles to the ACC controller, that compares the object data with the ACC vehicle's expected future course to select the relevant vehicle.

Measurement data of sensors are usually affected by noise. Filters, therefore, need to continuously filter out the noise and smoothen the sensor data. In general, several targets appear in the field of view. However, only the objects which are on a potential collision course should be taken into account for distance control, that means only those objects which lie in or intend to enter a driving corridor of a certain length e.g. of the stopping distance. In order to determine the object trajectories and the collision course, the motion of the own vehicle and the motion of the objects in the plane must be known. Estimations of the driving corridor i.e. the most likely path of the own vehicle motion e.g. within the next 4-5 seconds, are done by either using image processing to extract the road course or by extrapolating the actual vehicle path from the knowledge on the actual vehicle dynamics and the most likely steering inputs. Either way, leading to predictions of the driving corridor and the behaviour of the relevant target.

Generally, the relevant target is the closest vehicle driving in the same direction along that course. The distance and relative speed values of the relevant car are then fed to a control part, which has to reduce the relative speed as well as the difference between the actual and the set distance to zero. When no relevant vehicle has been detected the ACC system only controls speed and functions just like cruise control.

The degree of assistance that can be provided to the driver depends essentially on the reliability of the different sensor information. Compared to the driver, who cannot estimate headway and relative velocity of preceding vehicles very accurately (see section 3.3.1), ACC systems have precise data about surrounding traffic objects as long as they remain within the radar sensors field of view.

This information can be used for a very precise and sensitive distance control function, which works very well on highways and major country roads, however, especially under transient conditions e.g. the road changing from straight to curve, uncertainty in object / lane assignment can occur, leading to misinterpretation of the traffic situation (Fancher et al., 1998; Prestl et al., 2000). Further, due to the complexity of the driving scenes and the quality and reliability of the sensor information, the possibility of failures and misinterpretations of the information can not be excluded. Dorissen & Hoever (1996), for example, report late

detections and loss of target vehicles, as well as switches in the detection between the lead vehicle and various objects on the side of the road. Brockmann et al. (1995) reported that target detection errors accounted for 11% of system errors, of which 6% led to a system intervention.

Longitudinal control

The longitudinal control has to manage the actuator systems in order to achieve the desired acceleration calculated by the ACC controller. Depending on the set value of the acceleration, either the drive train or the brakes will be activated. In the case of a wrong object detection, the longitudinal control may lead to surprising accelerations of the system (Brockmann et al., 1995).

The human-machine interface

The driver has to activate, operate, supervise and when necessary, reclaim control of the ACC system. As in conventional cruise control, the driver can adjust the desired maximum speed. Additionally, the driver controls the set distance value. This set distance is proportional to the vehicle speed. It represents a constant time gap between the preceding vehicle and the ACC vehicle. As part of the system philosophy, the set distance is adjustable so that the driver can take on full responsibility for driving the car when using ACC e.g. increasing headway in bad weather or in poor visibility conditions.

As part of the system philosophy, in-built system limitations such as its deceleration and acceleration capabilities (see *Figure 4*) were implemented to ensure on the one hand, that system limits are frequently reached where a take-over of the longitudinal control by the driver is necessary and on the other hand, to avoid irritation of the driver and the surrounding traffic in case of inappropriate control reactions (Prestl et al., 2000).

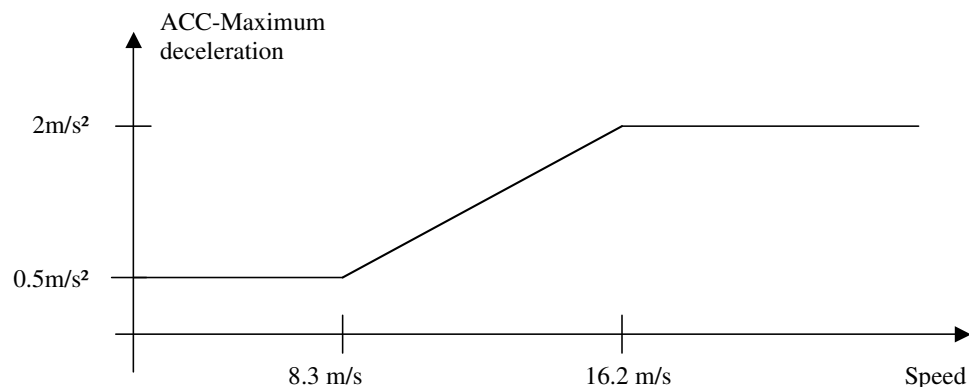

Figure 4. Speed-dependent ACC deceleration

As mentioned above, further limitations of the system include a field of view restricted to 150 m, the limited certainty of situation interpretation, the unsure detection of certain vehicle types (motorcycles, lorries) and the un-detectability of vehicles at standstill. The human-machine interface is thus charged with the difficult task of communicating the in-built system limitations as well as the sensoric shortcomings and faulty diagnoses. Due to the difficulty of situation interpretation and of the other abovementioned limits of the system, ACC systems must be classified as convenience systems, capable of providing assistance to the driver but never relieving the driver of his / her responsibility for vehicle guidance and the driving task.

Research on ACC has been ongoing for many years. Since the system’s early developments, both automotive companies and traffic research institutions have conducted studies addressing its impacts on human vehicle interaction. Studies on ACC can be broadly divided into those that have been conducted in a driving simulator and those conducted in real road conditions. ACC simulator studies can be divided into those conducted in a fixed-based and those conducted in a moving-based simulator. The following studies were conducted in fixed-based simulator: Brook-carter et al. (2002); Comte & Jamson (1998); Hogema & Janssen (1996); Hogema et al. (1997); Hogema et al. (1995); Janssen & Nilsson (1993); Stanton et al. (1997); Stanton & Young (1998); Stanton & Young (2000) and van der Hulst (1999). Studies by Buld et al. (2002), Nilsson (1995) and Törnros et al. (2002) were conducted in a moving-based simulator.

ACC field studies were conducted by Becker et al. (1997); Becker et al. (1994); Brockmann et al. (1995); Chaloupka (1998); Dorißen & Hoever (1996); Fancher et al. (1998); Fancher & Ervin (1998); Fastenmeier & Gstalter (1998); Kopf & Nirschl (1997); McLaughlin & Serafin (1999); Nirschl et al. (2000); Risser & Lehner (1997); Saad & Villame (1996); Weinberger (2000) and Winner et al. (1996).

In response to the difficulties presented by the human-machine interface, a number of studies compared the effects of different ACC system designs on drivers’ behaviour. A so-called ‘foot-on-gas’ design, for example, was compared to a ‘foot-off-gas’ design (Brockmann et al., 1995; Chaloupka et al., 1998; Hogema & Janssen, 1996; Hogema et al., 1997; Risser & Lehner, 1997; van der Hulst, 1999). In the foot-on-gas design, drivers have to keep their foot on the accelerator pedal. Through a haptic signal, the force-feedback pedal would let drivers know when the set desired speed or the set distance to the lead vehicle had been reached. In the foot-off-gas variation, drivers did not have to leave their foot on the pedal. The evaluation of these different designs gave way to the foot-off-gas design of ACC systems today.

The studies undertaken by Kopf & Nirschl (1997) and Nirschl et al. (2000) compared three ACC systems that varied in headway distance and maximum deceleration capability. The most extreme variation consisted of a high maximum deceleration and a short headway,

whereas the most conservative variation had a weak deceleration and a long headway. The results showed a better adaptation to the extreme and most conservative variations compared to the middle one.

Hogema et al. (1995) researched different forms of displays for presenting transmitted information on local speed limits. A reduction in speed was only found when the information was automatically taken over by the ACC system as the set desired speed. Brookhuis & De Waard (1999) and Molin & Brookhuis (2001) contended, however, that higher acceptance is yielded by presenting less intrusive visual feedback and by giving the possibility of personally setting a maximum speed as drivers feel less restrained.

Comte & Jamson (1998) analysed the influence of speed information conveyed by direct ACC interventions and a visual ACC display on drivers' behaviour in curves and in poor visibility conditions. No difference was found between condition in the compliance of speed limits. In the information display condition, a tendency towards earlier braking before the curve was observed. Although no differences in drivers' acceptance of the systems were found, the information display was considered the more practicable variation due to its comparative ease of use.

Aside from the studies related to different forms of ACC design, studies have also been conducted on the effects of ACC on drivers' behaviour. Typical driving patterns in terms of speed and headway suggest that a more constant speed and following behaviour is produced when the ACC system is engaged (Fancher et al., 1998; Hogema et al., 1994). Compared to manual driving, no change was found in mean driving speeds (Fancher et al., 1998). The reported influence of ACC on held headway distances seemed to be particularly dependent on the experimental methodology that was used (real drive or driving simulator). Compared to manual driving, mean headway tended to be shorter in simulator experiments and slightly longer in reported field studies (Chaloupka et al., 1998; Fancher et al., 1998). In real road conditions, this effect led to the increased likelihood of other vehicles cutting in front of the ACC vehicle. Saad & Villame's (1996) analysis of drivers' overtaking behaviour during ACC driving unveiled that generally less overtaking manoeuvres were undertaken, that drivers remained longer on the overtaking lane (particularly on two-lane carriageways) and that overtaking manoeuvres began slightly earlier than during manual driving. A possible explanation for this finding is the often criticised weak accelerations and decelerations of the system, in particular when overtaking or in the case of a slower vehicle cutting in (Fancher & Ervin, 1998; Fastenmeier & Gstalter, 1998; van der Hulst, 1999).

Further reported behavioural adaptations concerned drivers' delegation of responsibility to the ACC system (Risser & Lehner, 1997). System settings, for example, were often left unchanged for as long as possible in the attempt to prevent the system's deactivation. Consequences thereof was the reduced attention and consideration towards other road users

e.g. motorcycles, bicycles and pedestrians (Chaloupka et al., 1998; Risser & Lehner, 1997). Additionally, longer gaze times away from the road have been reported during ACC driving (Becker et al., 1994). This might be accounted to the combination of reported increased safety feelings and to the reduced mental workload during ACC driving (Fancher & Ervin, 1998; Risser & Lehner, 1997; Stanton et al., 1997; Stanton & Young, 1998; Törnros et al., 2002; Winner et al., 1996), an effect with possible detrimental consequences on attention .

An important consideration in reclaiming control when system limits are reached is drivers' attention. Although in most studies the short testing periods meant that no problems of attention occurred, concern was expressed that low workload levels during ACC driving could lead to reduced attention levels in critical situations (Brook-Carter et al., 2002; Chaloupka et al., 1998; Hogema et al., 1997; Stanton et al., 1997; Stanton & Young, 1998). Nilsson (1995), however, does not attribute slower driver reactions in these situations to reduced levels of attention. Instead, she maintains that drivers' misinterpretations of the situation, that lead to higher reaction times, is due to drivers excessive expectations of the ACC system.

Research on situations requiring drivers to actively intervene and reclaim control of the system in the driving simulator uncovered later reactions during ACC driving in approach situations to a standing vehicle at the end of a traffic jam (Hogema et al., 1995; Nilsson, 1995). In a following situation when the ACC system suddenly failed to operate, Stanton & Young (1998) found that one third of participants were unable to successfully reclaim control of the system. On real road conditions, higher decelerations were observed after control of the system had been reclaimed (Fancher et al., 1998). Drivers reported that the actuation of the ACC deceleration was a helpful signal to focus their attention to the traffic situation (Dorißen & Hoever, 1996; Fancher et al., 2001). Weinberger (2000) reported from an analysis of over 600 take-over situations, where drivers had been driving the system an average of 1300 km per week, a learning phase for reclaiming control of the system of approximately two weeks. Kopf & Nirschl (1997) report that over a 100 km drive, a learn effect in reclaiming control of the system was observable. When the drive was repeated a few days later, however, drivers were back at the level at which they started from. During the few days between each drive in which the ACC was not used, therefore, what had previously been learnt had been forgotten.

On the whole, despite drivers' concern that ACC might lead to a loss of attention, the majority of participants rated the safety effects of the system positively (Becker et al., 1997; Chaloupka et al., 1998; Fancher et al., 1998; Nilsson, 1995). Similarly, most drivers reported an increase in comfort when the system was engaged (Fancher et al., 1998; Hogema & Janssen, 1996; Nilsson, 1995). This may be due to the reduction of physical (Mc Laughlin & Serafin, 1999) but also mental workload (Brockmann et al., 1995; Brook-Carter et al., 2002; Fancher &

Ervin, 1998; Risser & Lehner, 1997; Stanton et al., 1997; Stanton & Young, 1998; Winner et al., 1996). Overall, participants’ response to the system was positive and, as opposed to lane assistance support systems, participants showed more tolerance towards incorrect system reactions.

It is important to note, however, that in the majority of the studies, participants could only use the system for a relatively short period of time, a couple of hours at most. The results from participants’ subjective assessments therefore, draw mainly upon their first impressions of the system. Consideration should be given to the fact that within the short available time, the learning phase had undoubtedly not yet been completed. The research conducted by Fancher et al. (1998) distinguishes itself from other studies as participants had the possibility to use the ACC system over a four week period. Without considerable prior work, however, the results can not be transferred to other systems with automatic braking intervention or other traffic environments that differ from those in Northern America. Whereas in previous studies, one of the main aims was the comparison between different ACC system designs, today, at least in Europe, a relatively standardised concept has been established in which, for example, the driver does not have to apply the accelerator pedal while operating the system (ISO 15622, 2001).

2.4 The Environment

2.4.1 Classification of driving situations

The following situations are generally accepted as representing all the aspects related to the longitudinal driving task (Fastenmeier & Gstalter, 1998). These situational characteristics were adopted in this work and form the definitions for the traffic situations in the experimental studies. The parameters of the driving situations in the longitudinal driving task do not differ when compared with driving with the ACC system, however follow driving and platoon driving (and eventually Stop & Go) will be taken over.

Table 2. *Characteristics of the longitudinal driving task*

Task	Characteristics
Free driving	Free choice of lane and speed within the limits set by the Driving Code of Practice. Other vehicles (lead or preceding vehicles) have no influence on the choice of lane or speed. The time gap between lead or preceding vehicles is >2 seconds.
Follow driving	The time gap to the lead vehicle on the same lane is <2 seconds.

	The bordering lane is free.
Lead driving	The time gap to the preceding vehicle on the same lane is <2 seconds. The bordering lane is free.
Following and lead driving	The time gap to the lead vehicle on the same lane is <2 seconds The time gap to the preceding vehicle on the same lane is <2 seconds. The bordering lane is free.
Overtaking	The vehicle is not on the right lane A lane is occupied by slower vehicles
Being overtaken	One or more vehicles occupy the neighbouring lane and are driving at considerably higher speeds
Platoon driving	No choice of lane or speed All lanes going in the same direction are occupied Little variance in speed between and within lanes $v > 0km/h$
Stop & Go	No choice of lane or speed All lanes going in the same direction are occupied Little variance in speed between and within lanes $v_{max} < 30km/h$ At least one full stop will be performed
Switching between free driving and follow driving	The distance to the lead vehicle will fall below 2 seconds This could result from an approach to a vehicle driving on the same lane or as a result from the change of lane of the initiating vehicle or from another vehicle cutting in.

2.4.2 Environmental influences on driving with ACC

Environmental categories affecting ACC usage can be broadly defined into three categories: structural, meteorological and traffic dependent. This section considers the environmental limits of each category and discusses the impacts they may have on ACC driving.

Driving with ACC is theoretically possible on all road types, whether it be on town roads, country roads or motorways. ACC functions identically to normal cruise control systems when no lead vehicle has been detected. Thus, similarly to cruise control, ACC will be most frequently set on the motorway. However, if in follow-mode, the ACC will control the speed and distance to the car in front automatically thus becoming also applicable for use on other road types.

The first environmental limit refers to the road structure i.e. the type and curvature of the road, as well as to the road infrastructure. On arterial or B-type roads, the problem is often linked to the road curvature as well as to the occurrence of unexpected events necessitating an unforeseen emergency braking reaction. The problem with bendy roads is firstly, that speed will constantly need to be readjusted and secondly, in follow-mode, the lead vehicle is likely

to leave the radar’s detection area before it reaches the curve, necessitating the driver to actively decide and take action if the speed is still too high to successfully manage the curve. The difficulty on town roads stems principally from the low speed limitations (the ACC system switches itself off automatically at 30 km/h) but also from the general infrastructure, which necessitates the need for many full stops i.e. at traffic lights, crossings, parked vehicles on the road etc., as well as from the unexpected situations in which the sub-optimal foot position (away from the brake pedal) during ACC driving might delay necessary braking reactions. For these reasons, the motorway is the ideal road for ACC driving. The road infrastructure is good, speeds are reasonably high and the need for active braking can often be predicted in advance.

The second environmental limit can be attributed to meteorological conditions. Meteorological conditions consist mainly of extreme weather or poor visibility conditions. Radar technology, as opposed to laser technology is unaffected by extreme weather conditions such as heavy rain, snow or fog. In these situations, however, the driver is advised to inactivate the system for liability reasons. Although the system is capable of working in these situations, only the driver can be held responsible for accurate judgement of the appropriate speed and distance to be held. The failure of a rational decision to switch the system off in extreme conditions leads to a flagrant misuse and potential abuse of the system. Contrarily, night time driving with ACC does not pose a liability threat. Driving at night time, however, generally occurs after a familiarisation time with the system.

Finally, the third environmental limitation to driving with ACC concerns the fluidity of the traffic flow and the sheer amount of traffic. Heavily encumbered or traffic congested roads increases the likelihood of vehicles cutting into the lane and poses the threat of delayed or late system reactions. Further, congestions usually imply relatively low driving speeds at which ACC maximum deceleration is lowest. Drivers might thus quickly become overloaded by having to regularly reactivate the system as well as constantly assessing the situation to decide whether the system’s deceleration limits will be reached.

The impact of environmental factors on ACC driving can be objectified although very few publications have reported these effects. With regards to the type of road on which ACC was used, Fancher et al. (1998) reported in their field operational test that even though 90% of the total ACC engagement miles were travelled on motorways, very substantial levels of utilisation were exhibited on other road types. The data showed for example, that utilisation on arterial streets, at speeds above 55mph, was approximately 50% and, at speeds between 35 and 55 mph, utilisation on arterials was near 14%. The long-term ACC study performed on German roads by Nirschl & Blum (1999) showed that ACC was activated for 72.5% of the total kilometres driven on the motorway, for 44.7% on arterial roads and for as much as 13.2% on city roads. With regards to ACC usage behaviour in terms of visibility conditions,

no notable difference has been observed in the total percentage engagement of the system during day time and night time (Fecher et al., 2002; Nirschl & Blum, 1999). During the trial period, however, comparatively little driving was actually made at night. Similarly, too little data was collected on driving in rain or fog to make a statement on the influences of these conditions on speed and / or headway distance.

3 LEARNING TO DRIVE WITH ADAS

3.1 Automation vs. assistance

Automation can be defined as the execution by machine, usually a computer, of a function previously carried out by a human (Parasuraman, 2000). Given their rapid growth in speed, capacity and ‘intelligence’, computers are increasingly being assigned to functions that at one time could only be performed by humans, including complex cognitive activities such as decision making and planning. Albeit as an attempt to aid operators and even to relieve them of their duties to some extent so as to eliminate error, the introduction of automatic control raises a plethora of new concerns and problems.

An important finding is that automation can fundamentally change the nature of the cognitive demands and responsibilities of the human operators of systems, often in ways that were unintended or unanticipated by designers (Hancock & Parasuraman, 2003; Sheridan & Parasuraman, 2000). These issues are generally symptomatic of the transition in the role of the human from the operational to supervisory control or active to passive monitoring (Parasuraman & Riley, 1997; Scerbo, 1996).

Bainbridge (1983), in her seminal work of automation’s ironies puts forth that the typical tasks such as monitoring, diagnosis (which creates cognitive demands) and takeover (which requires manual skills), that designers were not able to automate, will suffer from skill degradation as, most often, after the task has been automated, operators are starved of rehearsal and feedback. Indeed, being out of the loop may cause two adverse effects: loss of manual skills and loss of awareness of the state and processes of the system (Endsley & Kiris, 1995). Adverse effects of monitoring sources of information for extended periods of time may be complacency, resulting in a lack of vigilance in monitoring the automation or over reliance, where drivers could come to rely on the system backing for them and thereby be at greater risk if the system should fail (Stanton et al., 1996), which is called risk compensation.

Much of the work on automation has examined factors that promote or limit effective use of automation by humans and the consequences for system efficiency and safety. Critical situations may occur, however, when automation fails and human intervention is required. The acuteness of such a situation is often related to the extent to which the operator is involved in controlling the system. Reason (1992) explains the Catch-22 of human supervisory control, in which humans come into contact with an automated system only when dealing with emergencies. Humans do this by drawing on stored knowledge of such. However, given the limited opportunity to practice procedural responses in an automated

system, coupled with the uniqueness of each emergency, operators' knowledge bases will be sparsely furnished. Thus, past experience counts for little. Reason (1992) concluded that supervisory control is a specifically ill-suited task to the limited cognitive capabilities of humans.

According to an alternative perspective, the problem is not automation per se, but is due to the fact that it is at an intermediate level of intelligence, thus requiring a higher amount of required learning (Norman, 1990b). Norman (1990a) and Krüger (2000) maintain that the amount of required learning is correlated to the degree of automation intelligence.

At extreme low and high levels of automation intelligence, the least amount of required learning will be needed to accomplish a task. Whereas at intermediate levels of automation intelligence, a higher amount of learning is required. This can be exemplified by considering the longitudinal control of the vehicle while driving. At low levels of automation intelligence, say, for example, using the cruise control, a simple rule, namely, if a slower car is in the trajectory, then the need for intervention is required, covers all eventualities. If the longitudinal driving task was fully automated, no rule would need to be learnt as the system would cope with all eventualities. At intermediate levels of automation, however, as with the case of ACC, a larger amount of required learning is necessary, corresponding to the various rules that apply to the different eventualities.

Automation per se, thus, may not be the problem but inappropriate design. Norman (1990a) suggested making automated systems either more or less intelligent (improvement or removal), but the current level is inappropriate under anything but normal conditions. Until advances in automation occur, however, Norman (1990a) specifically refers to the insufficiency in feedback as a major contributing factor. Thus, the culprit is not automation but a lack of continual feedback and interaction—a deficit that keeps operators “out of the loop”.

It is envisaged that, although the ACC system will behave in exactly the manner prescribed by the designers and programmers, this may lead to some scenarios in which the driver's perception of the situation is at odds with the system operation (Fancher et al., 1998; Kopf & Simon, 2001; Stanton & Young, 1998). Indeed, even those developing the systems recognise that ‘headway control raises the issue of whether the system matches the driver expectations with regard to braking and headway control’ (Richardson et al., 1997).

Until the necessary progress in the field of sensor technology and driving environment interpretation has been made to fully automate the longitudinal task, the psychological issues arising from systems partly-automating a driving task like the ACC need close consideration and need to be properly addressed to improve overall system performance.

In their model of the information flow between driver, automatics and vehicle sub-systems, Stanton & Marsden (1996) and Stanton & Young (2000) elicited and discussed the pertinent psychological factors associated with the operation of automated systems such as ACC. Most obvious was the issue of feedback. Of particular interest was the role of feedback to the driver from the automated system. As seen above, this tends to be poor because the automated systems do not require feedback to function. Relatedly, the development of the driver's trust in the automated system may depend upon appropriate feedback. According to Muir & Morray (1996), the amount of feedback sought from an automated system by a human operator is directly related to the degree of trust they have in it to perform without failure. Passing control of the vehicle to a computer raises the issue of locus of control in the driver: does the driver feel that they, or the computer, are ultimately in control of the automobile? The degree to which a symbiotic relationship exists between the driver and the automatic system could determine how successful vehicle automation is perceived.

Another important effect from the introduction of automation is its effect on drivers' workload. Automation is generally claimed to reduce the demands placed upon operators (Bainbridge, 1992). ACC studies (Brockmann et al., 1995; Fancher & Ervin, 1998; Risser & Lehner, 1997; Winner et al., 1996) have pointed out that when the system was engaged, more cognitive resources were able to be directed to other aspects of the situation. This included both aspects within the vehicle (unrelated to the driving task such as the instrumental panel) as well as the traffic situation. However, it has been demonstrated that monitoring of automated systems for malfunctions during prolonged periods of time induce high levels of workload, despite the fact that information-processing requirements for these tasks are low (De Ward et al., 1999). For the case of ACC driving, results even suggest that placing the operator out-of-the-loop can lead to reduced activation and in some cases to reduced situational awareness (van der Hulst, 1999; Ward, 2000)

One of the central concepts in driver automation is the extent to which the driver is aware of the state of the automatic system and the impact that has on the vehicle trajectory. Situational awareness depends, to a great extent, upon the development of an accurate mental model of the world, that enables information to be interpreted and predictions of future states made (Endsley, 1995). Today, a division is made between mental and situation models. Interaction, exposure and experience with the system shape user's mental models of the ACC. Mental models are more general, at a more abstract level. Situation models are built from the specific circumstances of a situation. The representation of the situation characteristics are built from stimuli from the environment as well as from the expectations and assumptions of the operator (Endsley, 2000). Thus, indispensable to the learning of complex systems, is the building of a correct mental model. Many authors, researching the field of dynamic systems

use the term mental model when describing the structure of knowledge, that is saved in long-term memory.

“...the mental model can be thought of as a representation of the typical causal interconnections involving actions and environmental events that influence the functioning of the system” (Durso & Gronlund, 1999).

A major purpose of a mental model is to enable the person to understand and anticipate the behaviour of a system (Williams et al., 1983). This means, in the case of the ACC system, that the model must have predictive power for the drivers about the state of the system, the feedback and the reproducibility of particular ACC situations. If the ACC was capable of performing the car-following task safely and comfortably under all circumstances, then the driver could effectively deactivate the manual car following mental model. However, given the current technological limitations, ACC systems will not be able to perform without human monitoring and intervention. It is important to consider how drivers may obtain and develop a mental model of the ACC and how they may use it. The driver’s mental model of the ACC should offer the driver a realistic assessment of ACC performance as well as an estimate of how long it can be left unmonitored. With a correct mental model of the automation, drivers can effectively assess whether manual control is favoured over automation in a particular context.

Hoedemaeker (1999), proposes the idea that the adaptation of the ACC mental model is the result of two processes that operate at different abstraction levels within the mental model. The first is based on the degree to which the expected behaviour, as provided by the ACC mental model, differs from the observed behaviour. Depending on the degree of wrong predictions, the ACC mental model is updated to arrive at a more accurate account of the ACC’s operational domain. The second process that affects mental model adaptation takes place at a higher abstraction level in the mental model. If it appears that adaptation of the ACC mental model does not reach a stable configuration because of apparent inconsistencies in the system’s behaviour, then trust, usefulness and efficiency attributed to the system decrease. The result is that drivers may start to rely less on the system and more on manual performance of the driving task. If, on the other hand, the ACC mental model does converge and the operational constraints are easily tied to a particular situation and conditions, then the driver may start to rely more on the system.

In this framework, trust is defined at a higher level of abstraction in the ACC mental model. The mental model of the ACC is primarily shaped through interaction with the physical system, resulting in a representation of the situations that an ACC can handle. Trust is shaped through evaluations of these levels in the ACC mental model. Similarly, usefulness, comfort and efficiency are subjective labels based on evaluation of mental model predictions.

Thus, drivers' internal 'mental models' of the system may provide predictive insights and help to explain users interaction and understanding of the system and also have the potential for uncovering specific user informational needs at different levels of their apprenticeship. However, mental models are extremely difficult to measure empirically. Questionnaires only make access to some elements of the mental model possible. Cooke (1999) proposes methods of cognitive task analysis, verbal protocolling, interviews or observation for problem solving procedures. Other researches have used performance measures or error analyses for their assessment (Hollnagel, 1998). Independently of the selected method, however, the question remains, whether the mental model has been fully acquired. Moray (1999) gives an important contribution to the description of the general structure of mental models in dynamic systems. He puts forth that by ordering mental models under explicit memory, learning complex systems from explicit knowledge can only be accounted for partly. What can not be explained, can therefore not feature in a subjective model, although the execution of the task might be mastered. Additionally, a subjective model could be faulty, without the execution of the task having to suffer.

Feedback, organisation of system knowledge and mental models of system functionality have implications for the way drivers interpret information and assistance from ADAS. Attitudes, however, are also likely to have a powerful effect on how information will be used to guide behaviour. Sophisticated systems provide drivers with substantial amounts of support in the driving task, however, the driver is still left to make the final decision. For instance, the system may start decelerating due to a lead vehicle but the driver has the final authority to accept or reject its recommendations. In this situation, the decision may depend on perceived system capabilities, trust in the system and the confidence the driver has in his or her own perceptions, knowledge or intuitions. Therefore, it seems likely that when driver self-confidence does not match driver capabilities, or when the driver's trust in the system does not match its capabilities, the system will be used when it is inappropriate or be ignored in favour of less optimal driver decisions (Rajaonah, 2001). Thus, the factors affecting driver calibrations of trust in the system and confidence in themselves will help determine how effectively the system will be used.

3.2 Usability criteria for ADAS

The ISO definition has proved effective as a means to specify the measures to be applied in usability testing. The International Standards Organisation (ISO) defines usability as:

"... the effectiveness, efficiency and satisfaction with which specified users can achieve specified goals in particular environments" (ISO 9241-11, 1994).

The three aspects of usability included in this definition—effectiveness, efficiency and satisfaction, each respectively refer to the extent to which a goal or task is achieved, the amount of effort required to accomplish a goal and the level of comfort that the users experience when using a product and how acceptable the product is to users as a means of achieving their goals. Each component described in part 11 of the ISO-norm 9241 can be expressed quantitatively. Effectiveness can be measured in terms of whether test participants are able to complete specified tasks. A distinction can be made between completion at the first attempt, completion on the second or subsequent attempts, completion with the use of a manual, completion with assistance from another person and failure to complete. On the basis of these distinctions, a picture can readily be built up of how intuitive and how learnable the operation of a product might be. Efficiency is measured in terms of the time taken to operate a product sometimes related to the number of errors made. An alternative measure of efficiency is to register all the individual actions a test participant makes in order to complete a task, including making errors and task recovery. The third aspect of the ISO definition is the measure of the attitudinal component of usability: satisfaction. Satisfaction is more subjective than effectiveness and efficiency and is usually measured ad hoc. This, however, does not mean that it is inherently any less important than the other two. Satisfaction might be seen as the most important aspect of usability for products whose use is voluntary. Conversely, in situations where people are ‘forced’ to use products, effectiveness and efficiency are seen as the most important. However, satisfaction will often be strongly correlated with effectiveness and efficiency.

In testing for usability, there is often emphasis on the functional and utilitarian aspects of usability. The issue of ‘usefulness’, with regard to designing computer systems, for example, is often broken down into two categories: utility and usability (Grudin, 1992), where utility is the question of whether the functionality of the system in principle can do what is needed, and usability is the question of how well users can use that functionality. The overall usability of the system, however, applies to all aspects of a system with which a human might interact.

It is important to realise that usability is not a single, one-dimensional property of a user interface (Stanton & Baber, 1996). Nielsen (1993) asserts that usability has multiple components and is traditionally associated with the following five usability attributes: learnability, efficiency, memorability, errors and satisfaction. By contrast, in his work on the principles and practice of design for usability, Shackel’s (1997) general framework embraces the four principal components of any work situation: user, task, system and environment. He affirms that good design for usability depends upon achieving successful harmony in the dynamic interplay of these four components. Therefore, Shackel (1997) defines usability in terms of the interaction between user, task and system in the environment.

The difficulty in reaching an agreed, coherent definition is the first, and perhaps most important, stumbling block in determining the criteria appropriate to usability testing and evaluation criteria for ADAS. Although the constituent ingredients are often similar, this plurality of meaning would suggest that a usability evaluation may not have a common standard between individuals. When designing for usability, therefore, it is important to bear in mind the effect of user characteristics on usability. Domain knowledge or previous experience with the system itself, for example, is likely to affect how easy or difficult it is to complete a particular task. Experience with similar in-vehicle systems will also affect how usable a new system is for a user. Other user characteristics that may also influence drivers interaction with the system include users cultural background, age and gender as well as population stereotypes for particular markets, particularly when systems have a safety critical aspect to them (Jordan, 1998).

Apart from the issue of ‘experience’, the user characteristics mentioned above may be thought of as comparatively stable. They are characteristics that, if they change at all, will probably change over a comparatively long period. However, users performance with a system is likely to improve significantly in relation to tasks which they repeat with the system over time. Thus the usability of a product for a particular person completing a particular task may change very quickly as the task is repeated. In other words, it may just take a little time to ‘get the hang’ of a product. To reflect this, Jordan (1994; Jordan et al., 1991) developed a three-component model of usability accounting for the change in level of task performance with repetition. The components are guessability, learnability and experienced user performance (EUP). These are associated with, respectively, first time use of a system for a particular task, the number of task repetitions required until an acceptable level of ‘competence’ is reached, and the relatively stable level of performance that an experienced system user reaches. A later extension of the model included an additional two components—system potential and re-usability (Green & Jordan, 2002). These are concerned with the theoretical optimal performance obtainable with a system with respect to particular tasks and the level of performance achieved when a user returns to a task with a system after an extended period of non-use. These components are not considered in this thesis but feature two important aspects of usability to be measured in view of the future integration of ADAS and when considering the long-term effects of these systems on users behavioural adaptation. Guessability and learnability are the main components of usability considered in this thesis. Definitions of each component are given below, based on the ISO definition of usability and the implications of these components are explained in terms of learning to use ADAS.

Guessability is a measure of the cost to the user in using a system to perform a new task for the first time—the lower the cost (for example, in terms of time on task or errors made) the

higher the guessability. Guessability is likely to be particularly important for systems that have a high proportion of one-off users, for example public information systems. Guessability is of less importance in situations where product operation is initially demonstrated to the user or where the user has training with a product. Examples might include aircraft control panels or military equipment, which are designed to be used by experts after considerable training. However, even with such complex systems, particular tasks must be guessable. The safety critical aspects of these systems, as with ADAS, make it necessary in case of an emergency, to guess the appropriate response even in situations that have never been encountered before.

Learnability is concerned with the cost to the user in reaching some competent level of performance with a task, but excluding the special difficulties associated with completing the task for the first time. If the method for performing a task proved easily memorable after the first completion, the system would, then, be highly learnable for this task. In the case of ADAS, in which the user of the system will acquaint himself with it while driving, in a discovery situation, usually without prior knowledge or training, learnability is primordial.

3.3 Learnability

A central element of learning is the differentiation between explicit and implicit memory. In the explicit memory, memories are stored in which a person is consciously aware during retrieval, whereas in implicit memory, memories are stored that a person is not consciously aware of retrieving. The quality of explanations are dependent of the quality of the semantic memory and of the stored understanding. Much of stored knowledge is not declarative and is stored in implicit memory. The knowledge has been learnt but it can not, or only under great strain, be explained. This applies especially to procedural memory, where most motor skills, but also other learned operative and cognitive procedures are stored (Anderson, 2000).

In relation to advanced driver assistance systems, system understanding plays an important role. If only considered in terms of what is explainable, it has only limited use as only a fraction of what is learnt can be explained explicitly. Methods used to check implicit knowledge, need to be orientated on the operational driving task i.e. need to be observable to the outside, because only when learnt procedures can be verbally explained, can methods measuring users unconscious procedures be used. Based upon this dichotomy, criteria of system understanding are twofold. Firstly, implicit system understanding, i.e. correct usage of the system that is observable from the outside, which bears on the unconscious, non-verbally explainable knowledge of the system. Secondly, explicit system understanding, i.e. verbally explainable understanding of the system's performance.

During the learning process, some will advance far quicker than others. Some might have understood even the technical underpinnings of the system while others might still be pondering on the system's very nature. The solution of providing the driver with the information about the system before setting off and only afterwards letting him consult the same source for feedback i.e. the system manual, from which he might only be able to uncover his misunderstandings from, seemed at very least, unsatisfactory. Effective learning requires learners to respond to each newly presented information and get feedback on their performance before advancing to the next. The learning of theoretical material, however, is different to learning the functionality and operational interaction with an automated system. Skilled practice arises only through practice. Thus, real-time feedback of the driver's behaviour is what would not only help him / her adapt the optimum driving behaviour but also help him / her to learn it more quickly. The method developed to this aim, is one of intelligent tutoring, or adapting the information given to a person to the his / her current performance level. This method of shaping, key to the concept of programmed instruction, breaks the material into small steps through careful sequencing. The steps are similar to what a skilled tutor would ask of an apprentice during one-to-one tuition. The first correct responses are prompted, but as performance improved, less and less help is given. After a certain period, shorter than mere trial and error, users attain a higher level of skilled behaviour and a more thorough understanding of the system (Cognition and Technology Group at Vanderbilt, 1993).

Intelligent tutor systems can, in principle, give the driver help in each and every task. A driver can be helped with the task of planning a trip, finding the way to the destination, avoiding accidents on the way to the destination and so forth. One danger in this possible development is that drivers may have a number of different intelligent tutor systems in the future car. The subtask 'to control (and interact with) other tasks in the car' may increase its proportion of the driver's different subtasks (see section 2.2.3). Failure to allocate intentional resources in an optimal way may increase the risk of distraction. To avoid the risks of information overload and distraction, it is necessary to take a perspective where intelligent tutor systems are designed so that they are adapted to drivers' cognitive abilities and limitations. The ideal goal is to give the drivers the information they need, at the right moment, in the right situation and in the right way. Some of the main critical psychological aspects and human limitations to be considered in the design of intelligent help systems for ADAS are now considered.

3.3.1 Critical aspects

Even the most complex driving assistance system becomes easy to use when users feel they are in control, that they know what to do, when to do it and what to expect from it whenever they perform an operation. In other words, when drivers have acquired a thorough

understanding of it. For a good understanding of the system, technical knowledge is not required, just functional knowledge. What is critical is that drivers have a good conceptual understanding of the system. Understanding comes about when the system presents a clear conceptual model of itself, making the possible actions apparent. A state described by Norman (1990b) as “knowledge in the world” –in other words, when the information in the world is enough to get an explicit conceptual grasp, so that no instructions, no training and no manuals are necessary.

Few users of an ACC system can understand the technology behind it, yet long-term users of the system feel comfortable using it because each control has a known function, they can tell when the system is functioning properly and they know its capabilities (Fancher et al., 1998; Weinberger, 2000). Problems arise when drivers feel out of control, when the controls and actions seem arbitrary, when actions do not lead to the expected results and when the system can get itself into peculiar states, peculiar in the sense that the person using it does not know what it is doing, how it got there or how to recover. ADAS will be successful if the users can retrieve this information and explain to others how it works, if users find innovative ways in which to use it and above all, if it lets users discover and learn it with minimum effort. With a special purpose system, such as the ACC system, everything about it can communicate to the driver what it does and how it works. Through the layout of the controls to the shape and form of the controls, significant information can be communicated to the driver but mainly, the display and feedback must be precise and to the point, explaining to the driver what is going on, why the actions are needed and what they are for. The notion that design can render anything “intuitively obvious” is false. In fact, intuition is simply a state of subconscious knowledge that usually comes about after extended practice and experience (Norman, 1998).

It has been shown that learning of skills proceeds from declarative processing (slow and rational) toward procedural (automated) skill (Anderson, 1993) in section 2.2.2. Thus, it could be suggested that people may learn to meet the demands of handling both the traffic situation and the intelligent tutor systems after some period of learning or that human limitations can be overcome by training.

There are, however, definite limits on the skilled processes, a limit that varies with situational factors as well as individual ones. These limits are defined by the sensorimotor characteristics of human beings (Card et al., 1983). The time taken to take a decision under a simple condition, for example, can, at best, be as short as 200 msec, in a laboratory setting with high preparation, good light conditions and no disturbing circumstances. For decisions in slightly more complex situations, like those of braking when seeing the braking light of the car in front, the reaction time increases by at least five times, up to 1 sec or more on average (Alm et al., 1997). Another example concerns the number of independent factors that a human being can attend to simultaneously (see section 2.2.1). If these factors are visual, only one single

object can be focused on, whereas other objects in proximity of this focused one may be caught by indirect sight. If the factors are acoustic, two factors may be attended to only if the processing does not require any details. Simple beeps may thus be distinguished from other auditory signals (like listening to the radio or road instructions). Of course, several factors may be paid attention to by time sharing, but then the time for moving attention from one factor to another has to be considered in the real-time driving situation. Further, it has been put forward, that people's information processing is hierarchically controlled (section 2.2.3). People have the possibility to make crude plans on a high (rational) level and to refine these plans on a lower (skilled) level according to the requirements of the particular situation. However, if the situation changes to the extent that the higher levels have to be involved, people still have to use the slow, rational processes again. These limitations of the human being should be considered in designing any support in the driving situation. In the following section, some requirements on the support are suggested, taking the human limitations into account.

It is self-evident that a support in the driving situation should not disturb the driver. However, how is it possible to assess the support versus the disturbance before actually having the support? General analyses of the relations between human error and automation may be found in, for instance, Reason (1992). Also, particular analyses of cockpit automation have been performed, from which other lessons can be learned (Hughes, 1995). However, in order to get into the particularities of a driving situation, the driving task has to be analysed in detail, as well as its possible support.

There are at least three kinds of support (Micron, 1993; Sviden, 1993): automatising of some of the driver's tasks i.e. lateral control or active cruise control which automatically slows down the vehicle to changes in the traffic pace, as a non-intrusive effective means of supporting the driver in keeping a safe distance to the car in front (see section 2.3.3); informing the driver about the road i.e. road and traffic support. This is most relevant to deliberate, rational decisions on a high level and should be offered only when the situation demands or when the driver requests it. In the first case, the information should be unobtrusive as possible, optimally visible (or audible) without interference with the lane keeping and traffic checking tasks. In the second case, it is possible to envisage a more involved information, for instance, before the trip or during the trip on a parking lot on the side of the road. This information then serves the higher level, rational plan. The last kind of support, alerting the driver to critical information is useful both when the driver's attention is overloaded by the complexity of the situation and when the drivers' vigilance is low due to a long, monotonous driving time. This kind of alert should be sparse, however, in order to be effective, carefully timed, and given in an adequate modality. A possible solution would be to make the presentation of information from tutor systems dependent on the static parts of the

traffic environment (Verwey, 1992). For instance, do not present any message when drivers are driving in a situation where their workload is high e.g. at a roundabout.

Beyond the human limitations of information processing, the restraints posed by the vehicle environment in terms of content and prioritisation of information and warnings need to be adhered to. The guidelines set out in the message priority scheme: SAE J2395 and the message priority committee draft: ISO Norm CD16591, propose a very similar sequencing of information with safety critical content as the highest priority followed by time urgency and operational relevance. Beyond content, many parameters need to be respected; from the physical composition of the sound e.g. amplitude, pitch, frequency, distance to the driver, to important linguistic dimensions e.g. prosody and sentence structure (Sorkin, 1987; Sorkin & Kantowitz, 1987).

Usually, the traffic situation is overloaded by visual cues, support may be tactile or kinaesthetic but the use of auditory displays have the advantage of being omni-directional, quick to alert the driver by conveying a message directly (and issuing warnings when necessary) but also effective at drawing attention (even to an associated visual display if required). The design of speech output in the vehicle has numerous advantages over visual displays, in terms of driver distraction (ISO 15005, 2000) and in vehicle cockpits, where space for the location of visual displays is at a premium. However, due to the limited amount of spare attention during driving, for example, auditory displays are not suitable for communicating long messages (Sorkin, 1987) or due to reduced levels of concentration, auditory displays should be capable of being repeated if missed the first time (Stevens et al., 1999).

In the next section, consideration is given to the ways in which drivers system understanding and learned acquisitions can be tested. We take a look at what it means to have learnt a system and the methods for quantifying this knowledge.

3.3.2 Success criteria

Success criteria are understood to be the criteria based upon which it can be shown that a driver has learnt a system and is capable of using it efficiently, effectively and safely. On what observable criteria can it be decided, however, whether a driver has mastered an ADAS? This seemingly simple question, very quickly becomes complicated as one considers the different facets involved. For example, should the entire system with all part functions be mastered or is it enough for the driver to master only those functions which he will really use? How is mastery defined? This question is quantitative: which level of system usage is accepted as mastery? as well as qualitative: is the correct usage of the system enough or should a correct knowledge of the system be present? Learning criteria can be divided into three levels (Krüger, 2000):

System-related criteria:

- Full usage of all functions
- Error free and efficient operation

Driver-related criteria:

- The driver's workload from the system reaches an asymptote
- Comfort and/ or improvement of information is not further improvable
- The driver's subjective driving safety reaches an asymptote

Safety-related criteria

- No more safety-relevant behaviour during operation
- No more safety-relevant driving errors
- Driver will not lead the system to crash
- System breakdown no longer leads to safety-critical situations

The accomplishment of the criteria on one level alone is not enough for the assessment of the effect of ADAS on driving safety. The system related criteria are a good example of this: they are at the forefront of testing as they are a pre-requisite for operating and usage of the system. Dependent on the learning ability of a driver, it is still very possible that this criterion is reached, even though he or she might still need to re-allocate considerable resources (effort) and that comfort and subjective feelings of safety have not yet reached optimal levels. Independently from a competent, workload free confident mastery of the system, the operational behaviour itself becomes a central learning criterion. For example, to fulfil a need which is not directly related to driving information-/multimedia system can lead to safety critical attention deficits in the driving task and therefore to driving errors. A further safety related criterion is the driver's skill to react to a system breakdown. This means accomplishing the task either without additional information of the system or without a deceleration in taking the driving task over from the system.

With the tendency for increased in-vehicle complexity resulting from the integration of driver assistance and information systems, information that will help drivers gain the necessary understanding in at least, say, the system limits, becomes increasingly necessary. Actual and future systems are therefore to be analysed in terms of the necessary knowledge drivers need for a safe usage of the system. The presentation as well as the content of this knowledge needs to be adapted to the driver and communicated in a user-oriented language that replaces the technical terminology with familiar terms. This principle needs further to be applied to the visual presentation of information in the display.

From the learning criteria, the components upon which a progression in learning can be derived. Learning is typically measured in terms of the:

- Number of correctly repeated procedures and the accuracy of each repetition
- Time spent on each procedure i.e. speed at which procedures are executed

Improvements in one or both of these components, indicates increased learning which can also be described as an increase in ease in accomplishing the particular task. From this ‘easiness’—presented as a decrease in resources needed to execute the task—further criteria for learning can be deduced such as:

- The possibility to perform additional tasks beside the learned task or the task to learn, increases as learning progresses.
- Physiological workload associated to performing the task will decrease as learning progresses.

3.3.3 Types of errors committed

In the execution of tasks, particularly during the learning period, errors are committed. Although certain kinds of errors will be inevitable, the concepts presented in this work were concerned as much with controlling the different kinds of errors in drivers’ interactions with ADAS e.g. misses versus false alarms, as with eliminating them. This sub-section presents different types of errors committed when operating systems.

Although various forms of error taxonomies have been proposed, two roughly parallel developments by Norman and Reason have revealed an important dichotomy: mistakes and slips. Errors of interpretation or of the choice of intentions are called mistakes. Mistakes can result from the shortcomings of perception, memory and cognition. Reason (1992), using Rasmussen’s (1983) terminology, has discriminated between knowledge-based and rule-based mistakes. Knowledge-based mistakes resemble decision-making errors, in which incorrect plans of actions are arrived at because of a failure to understand the situation. The operator is often overwhelmed by the complexity of evidence and lacks the knowledge or clear display of information to interpret it correctly. Rule-based mistakes, in contrast, occur when operators are more confident. They know (or believe they know) the situation and they invoke a rule or plan of action to deal with it. The likelihood of making a mistake while functioning at a knowledge-based level is higher than at a rule-based level (reason), because there are so many more ways in which information processing can fail – through shortcomings of attention, working memory, logical reasoning and decision making. However, subtle distinctions in the environment or context may lead to a “bad rule” being applied in which the conditions were misinterpreted or the rule was poorly chosen.

In contrast to mistakes, in which the intended action is wrong, slips are errors in which the right intention is incorrectly carried out. Slips or “capture errors” result when the intended

behaviour is captured by a similar, well practiced behaviour pattern. Reason (1992) argues that such a capture may take place for three reasons: Firstly, the intended action (or action sequence) involves a slight departure from the routine. Secondly, some characteristics of either the stimulus environment or the action sequence itself is closely related to the now inappropriate (but more frequent) action and thirdly, the action sequence is relatively automated and therefore not monitored closely by attention. In the absence of close attention, the standard action sequence could easily capture the stream of behaviour.

Whereas slips represent the commission of an incorrect action, lapses represent the failure to carry out an action. As such they can be directly tied to failures of memory. The typical lapse is what is colloquially referred to as forgetfulness. A major cause of lapses are interruptions. Mode errors result when an appropriate action is performed in a different, inappropriate mode because the operator has not remembered the context. Mode errors are of particular concern in automated systems. Mode errors are a joint consequence of relatively automated performance or of high workload.

These categories of error can be distinguished in an number of respects. Knowledge-based mistakes, for example, tend to be characteristic of a relatively low level of experience with the situation and a high attention demand on the task, whereas rule-based mistakes, and particularly slips, are associated with higher skill levels. One of the most important contrast between slips, on the one hand, and mistakes and lapses, on the other, is in the ease of detectability. The detection of slips appears to be relatively easy because people typically monitor, consciously or unconsciously, their motor output, and when the feedback of this output fails to match the expected feedback, the discrepancy is very easily detected e.g. decreasing instead of increasing the desired speed. In contrast, when the intentions are wrong (mistakes), any feedback about the error might not go detected.

Towards error remediation in the context of ADAS, the solutions proposed in this thesis are implicit to the discussion in (Norman, 1990b; Reason, 1992; Senders & Moray, 1991). When slips occur, they cannot be easily detected (and hence corrected) if the consequences of actions cannot be seen. Hence, beyond the visible feedback that the ACC gives on the different operation modes and the switches and controls, a module was implemented that explains the way in which the system carries out its operation. By incorporating response feedback and system operation feedback, the module helped support an accurate updating of a mental model.

Operating relatively complex ADAS in the complex driving environment, the specification of a single 'correct' precise sequence of step-by-step procedures is not always possible. The human operator must be opportunistic, responding differently according to the conditions of the moment. Under such circumstances, it becomes nearly essential for the operator to be able

to explore the limits of the system, particularly when the operator is learning the system characteristics and developing a good mental model. This makes a certain amount of error inevitable, if not desirable (Wickens, 1992). Thus, the approach adopted has been towards an error-tolerant design (Johnson, 1996) which proposes a fairly sophisticated intelligent monitoring system that continuously makes inferences about the driver's actions. If the system infers, on the basis of human output and system status, that those intentions are in danger of violating safety, or if human actions have been committed that are inconsistent with the inferred intentions, a graded series of advisory warnings are actuated. These run from increased vigilance of human performance monitoring by the system through changes in the visual and/ or acoustic display, to feedback of the nature of the error (allowing the driver to disregard it if he or she chooses).

3.3.4 Integration of driving with ADAS into normal driving behaviour

There is a range of psychological models, either specific driver behaviour theories or general task performance theories that can, to some degree predict driving behaviour. Models of driving behaviour are placed within a hierarchical structure of driving tasks (see section 2.2.3) and make predictions about different aspects of the driving task. These models are discussed here with regard to the implementation of ADAS and of its integration into normal driving behaviour.

At the strategic level, motivational models such as decision making theory behaviour and risk handling consider the driver as an active information seeker rather than the passive responder implicit in many information processing models. Motivational models address driving in its entirety and emphasise the inherent variability in driving.

A number of motivational models focus on drivers' risk handling and threat avoidance, for example Wilde's (Wilde, 1994) risk homeostasis theory, Näätänen & Summala's (1974) zero-risk theory and Fuller's (1984) threat-avoidance theory. All these theories assume that drivers select the amount of risk they are willing to tolerate in any given situation. The risk associated with possible outcomes is seen as the main factor influencing behaviour. However, these models also assume that drivers do not generally make a conscious analysis of the risks associated with alternative outcomes (Ranney, 1994).

Wilde's Risk Homeostasis Theory (RHT) is based on the assumption that the level of accepted subjective risk is a relatively stable personal parameter. Individual differences in this model refer to differences in motivational state that may affect the target level of risk. The RHT consists of an individual model of driver behaviour and an aggregate model that relates driver behaviour to accident rate. In the individual model, the driver is assumed to have a target level of risk that represents the amount of accident risk the driver accepts and wants to attain. When there is a discrepancy between perceived risk and target level of risk, the driver

makes a behavioural change. Aggregated over all road users, these behavioural changes or adjustments will produce a fixed rate of accident frequency and severity. An important implication is that drivers will compensate for perceived traffic safety improvements by adjusting their driving behaviour to re-establish the target level of risk. Very typical of homeostatic processes is variation in the level of the target. So, homeostasis does not mean consistency. A homeostatic process makes it possible to extract long-term steadiness from short-term fluctuations.

A lot of controversy has arisen over Wilde's hypothesis in the sense that safety improvements will not work unless it affects the target level of risk (McKenna, 1988). The ability of drivers to monitor accident risk has been questioned and the assertion that drivers experience or accept risk has been challenged (Evans, 1991). The plausibility of seeking some level of risk has been seriously doubted and, according to several authors, drivers seek the lowest possible, or zero, level of risk.

Näätänen & Summala (1974) developed the zero-risk theory. An important difference with the RHT is that in this theory the driver is assumed to accept no risk at all, that is, the target level of risk is zero. The subjective risk monitor is a crucial element in this model. It was conceptualised as a monitor that generates different degrees of subjective risk depending on the present or expected traffic situation. Activation of subjective risk inhibits ongoing behaviour in the sense that it results in behaviour such as slowing down. In later publications (Summala, 1988), the concept of safety instead of risk was stressed. Drivers control and maintain of safety margins was analysed, since normally the driver gives no consideration to risk.

Fuller (1984) raises the question as to how subjective risk reactions can be an important determinant of driver behaviour at all when the subjective risk of an accident is most of the time zero. In his threat-avoidance model, drivers are believed to be motivated to avoid aversive stimuli or situations. The concept of risk is not used at all. Fuller talks about potential aversive stimuli or threats because the driver's own actions determine whether or not interactions with the road environment will be punishing, stimuli in the road environment have an aversive potential. Because of the conditioning of anticipatory avoidance responses to particular discriminative stimuli, road users have learned specific choice production rules that generally lead to rewarding choices in that they prevent the experience of risk.

When comparing the three models of risk handling, the most salient difference is between risk homeostasis on the one hand and the other two models on the other. From these risk-handling theories, it can be concluded that the best traffic safety measures are those that decrease objective risk but increase subjective risk. It has been found that drivers tend to adapt to diverse driving conditions such as road surface, the presence of ABS (Anti-lock Brake

System), visibility and numerous other factors that may affect accident likelihood. Many authors have stressed the potential safety benefits of decreasing subjective risk without changing objective risk. An example can be found in the painting of a geometric pattern of bars with decreasing spacing on the road to reduce speeds by convincing drivers they are travelling faster than they actually are.

In conclusion, a range of motivational factors may play a role in driver's behaviour on the road and his/ her reaction to the automation of the driving task. The models discussed show that at the strategical level of driving behaviour it is important that driver support systems match the needs of the driver. These needs are concerned with risk, pleasure, expediency, costs and speed. They form the personal weights in the decision making utility functions of drivers and may influence the attitudes of drivers towards automation of the driving task. In line with the risk handling theories, it can be expected that, to the extent driver assistance systems are perceived as a safety benefit, they may effect a reduction in the perception of driving risk when using the system (Ward, 1996). In accordance with the tenets of the risk homeostasis theory, this perceived reduction may precipitate a higher risk driving style through higher speeds and shorter headways. This feature of RHT has been gaining empirical support through the work of Hoyes et al. (1996) and Stanton & Pinto (2000), not least, in Aschenbrenner & Biehl's (1994) Munich taxi-cab experiment. ABS makes the environment safer by allowing the vehicle's brakes to work their optimum across all situations. In the Munich experiment, taxi drivers who were aware that they were using vehicles fitted with ABS tended to drive faster, brake later, and corner harder compared to those who did not have the system fitted. Consequently, intrinsic risk as experienced by the driver is reduced. As a result, it is argued that driver behaviour adapts to attain the same level of target risk and allow drivers to extract a greater level of utility in terms of arriving at destinations quicker, for example.

Taking this example, it is possible to argue the case for RHT by moving away from a macro-level, population-level determination of target risk to a micro-level, behaviour compensation model at an individual level. However, an important point is that the behavioural adaptation caused by ABS, or indeed any other system, is not necessarily appropriate for the actual level of performance offered by the system (Walker et al., 2001). In the case of ABS, the design of the system does not mean that the vehicle will not slide or drift if using the brakes while cornering, or that in some circumstances a non-ABS-equipped vehicle will be able to stop in identical distances. Similarly, in the case of ACC, a late detection due a steep curve, motorbike, lorry or cyclist, might subject the braking reaction of the system to considerable delay. The implications of the empirical evidence of this phenomenon can also be extended to informational or warning systems. Indeed, the behavioural adaptation to collision warnings might also veer towards a more risky behaviour as intrinsic risk of colliding is reduced (Lee, 1999).

3.4 Methodological concepts to improve learning to drive with ADAS

In an open learning environment, the learner decides, him or herself, when, where, what and how to learn. Thus, learning in an open environment is a special case of self-regulated or self-directed learning. Adaptivity is present in a learning environment when there is an optimal dynamic fit between the amount of support a learner needs for learning and the amount of support the learning provides. The work presented in this thesis presents solutions to how an individual's need for support can be met within an open learning environment such as the vehicle. This section is organised into two parts. In the first part, in order to be able to answer questions like "What kind of support should be provided?" and "Which should be adapted to what?", a few basic perceptual human factors issues in driving and warning design principles are considered. In the second part, two methodological principles of adapting information to open learning environments are outlined and the implications for the design of the two methodological concepts for learning to use ADAS are presented.

3.4.1 Design principles

As previously mentioned, accident statistics show that rear-end collisions represent approximately 25% of all car crashes on public roads (NHTSA, 2002). The study of long-term use of ACC showed that 56% of take over situations in which hard or panic braking was executed were approach situations with a high relative velocity or a situation in which the lead car brakes. As mentioned in section 2.2, a contributing factor to most vehicle crashes is some form of driver error. In particular, drivers suffer from a variety of recognition errors in which the driver does not properly perceive, comprehend or react to a situation requiring a response. On the one hand, a certain inattention, distraction, leading to reduced situational awareness possibly due to inattention or distraction seem to be stake, and on the other hand, there is evidence that complex perceptual factors seem to be the cause. These factors will now be considered individually for the case of rear-end crashes.

The loss of situation awareness includes inattention, distraction and situations in which the driver looked but did not see a hazard until it was too late. With respect to rear-end crashes, Evans' (1991) study looked at the possible causes of complacency that allow drivers to drift from the important visual scanning and vehicle operation tasks at hand. According to his research, there are two likely reasons why drivers tend to become comfortable in following at headways that increase the risk of involvement in rear-end crashes. First, a dominant cue when following is the relative speed between the vehicle behind and the one in front. In normal vehicle following, relative speed is very close to zero. There is no risk of a rear-end crash if both vehicles maintain identical speeds, regardless of the speed at which they are travelling. Evans believes that the largely static visual impression in vehicle following tends

to lower awareness of speed. Second, according to Evans, drivers become comfortable when following too closely because they have learned, from repeated experience, that it is safe to do so, in the sense that they have been doing it for years without adverse consequences. Evans also indicated that experience teaches drivers that the vehicle in front does not suddenly slow down very often.

Considerable evidence suggests that rear-end crashes may occur because the driver of the preceding vehicle does not see the vehicle ahead or because of complex perceptual factors (Dingus et al., 1998). Several perceptual factors are present in determining distance and rate of closure information for following vehicles. When making judgements regarding depth, pictorial cues such as relative size can be one of the strongest depth cues (Levine & Shefner, 1991). As the distance to a lead vehicle decreases, the apparent size of the lead vehicle will increase nonlinearly (Mortimer, 1990). That is to say, when a driver is closing in on a vehicle, the relative size increases at a much slower rate initially compared to when the vehicles are close. Thus it is more difficult for the driver to judge closure rate when a vehicle is some distance away. Considered in light of driver behaviour of scanning multiple locations in the environment, it is apparent that crashes involving considerably slower preceding vehicle or stationary vehicles may be caused partly by a failure of the driver to recognise the high relative velocity.

Very little work has been reported on the ability of humans to perceive and scale the relative motion between vehicles and to take appropriate control actions in order to avoid a collision. The most direct measure of drivers' estimate of the risk of a rear-end accident is the perceived time-to-collision (TTC). This is the time it would take a following vehicle to collide with a leading vehicle if the current relative velocity were maintained from the given headway (Hoffman & Mortimer, 1994). The approach used in most studies examining TTC (Hoffman & Mortimer, 1994) or time to contact (Hancock & Manser, 1997; Tresilian, 1991), involves a display terminal or a projection screen upon which the participants view an object approaching them on a head on collision or a close by-pass trajectory. At some point during the presentation, the approaching object "disappears". The participants' task then is to respond when they think the object would either have collided with them or past next to them had it not disappeared. The findings of this removal paradigm have revealed several consistent characteristics. One consistent finding is that individuals progressively underestimate TTC as actual TTC increases. Tresilian (1995) indicates that estimates of TTC are generally 60% of actual TTC and that in general, there is about 50% variability in estimates of TTC. A second finding is that individuals are progressively more accurate estimating TTC with increased viewing time of the approaching object (Manser & Hancock, 1996). However, in these experiments, where the observer or the background was stationary, information about the absolute velocity of the vehicle is available to the driver from different

sources. In the case of the stationary observer, the sources of vehicle speed information are the expansion of the approaching vehicle and movement of the vehicle relative to the ground. In the case of the observer moving with the vehicle, speed information is available from the streaming of the visual field and movement of the vehicle relative to the ground. As the ratio of estimated to actual TTC is similar in both these cases, it would appear that the sources of information for estimating TTC are expansion of the approaching object and the perceived speed of the vehicle in closing the gap between the vehicle and the observer (Taieb-Maimon & Shinar, 2001).

An experiment reported by Hoffman & Mortimer (1994), determined the ability of subjects to estimate the TTC under conditions where both vehicles were in motion. A situation where there is little visual information to be gained from the environment about absolute speed of approach as the streaming information is not available and nor is the information relating to the absolute velocity between the vehicles. The only source of information for estimating TTC would then appear to be the change in visual angle (or expansion) of the lead vehicle i.e. τ and the acceleration or deceleration of this quantity i.e. $\dot{\tau}$. An important difference between the results of this experiment and those of others is that the amount of underestimation of the TTC is less. The difference in results is not due to differences in viewing time as similar viewing times were used. Thus, Hoffman & Mortimer (1994) advance that the difference may lie in the form of visual information available to the following driver in this experiment as here both vehicles were in motion and no other experiment had reported this condition. Thus, with the elimination of absolute speed information, estimation of TTC was improved. The conclusion could be made that the availability of information about speed relative to ground actually reduces the accuracy of estimation of TTC, as situations where only the visual expansion of the object is available yield the better estimates.

The ACC system assists drivers in holding a safe distance to the lead vehicle, however, in approach situations, these distances may be small and relative velocities fairly large inducing relatively small TTC. These are conditions in which rear-end accidents are likely to occur, but they are also the ones in which the angular velocity is above threshold i.e. 0.003 to 0.004 radians per second (Hoffman & Mortimer, 1994). During the use of the ACC system, especially during initial stages of use, drivers need to learn the system's programmed deceleration capabilities during the approach to a lead vehicle (Prestl et al., 2000; Simon & Kopf, 2001; Weinberger, 2000). When the driver perceives a critical situation, time is consumed in moving the foot from the accelerator to the brake and waiting for the vehicle to be slowed, additionally, drivers foot position in relation to the brake pedal has been shown to be positioned farther during ACC driving (Mc Laughlin & Serafin, 1999). Further, during ACC driving, braking onset may be delayed due to the additional decision process of waiting to see if the system's brake activation will suffice (Hattori et al., 1995; Simon, 2002). Thus,

driving with an ACC system in the above mentioned 'approach situations' adds further complications to the estimates of TTC.

Drivers are able to make relatively accurate estimates on the distance to the car in front of them and are reasonably sensitive in determining a change in the headway between their vehicle and the one ahead of them. Research has found that in many situations, drivers do not have the opportunity to estimate relative velocity because the threshold for human perception of the relative velocity is often not exceeded, therefore unless the relative velocity between two vehicles becomes quite high, drivers will respond to changes in their headway or the change in angular size of the vehicle ahead and use that as a cue to determine the need to adjust their following speed. The pattern of optical expansion, referred to as 'looming' (Smith et al., 2001) plays an important role in driver's control behaviour and could thus represent a powerful source of information to specify the approach criticality and/ or impending collision. Thus, to help drivers learn the system limits and reduce the risk of rear-end collisions, advisory displays should be designed with the intention of increasing situation awareness and improving driver response in conditions for which judgement may be difficult. Drivers could be aided by timely feedback through an analogue display that indicates looming in approach situations, or the velocity of the car being followed from which the relative velocity could be deducted, as drivers know the velocity of their own vehicle.

Warning a driver of an imminent crash compared with giving advisory and proximal location information projects fundamental differences in the design implications of warning systems. A primary difference is a reduced amount of response time for avoiding the hazard. Advisory and proximity displays serve largely as a continual training tool and possibly as a sensory enhancement tool when conditions of reduced visibility are present. Collision warning displays, however, require a correct and immediate response for crash avoidance. The reaction time that drivers need for making such a response is very diverse, complicating the resulting design of such systems.

The correct driver reaction to a potential crash situation is rapid braking or steering. As a major consequence, one of the main factors determining whether the crash will be avoided is the driver's reaction time. Reaction time has long been the object of study but specific mention of reaction time as it relates to in-vehicle braking is somewhat sparse because of the safety implications involved with the study of true emergency response circumstances. Past research has generally concentrated on reaction to traffic signals and reaction to objects on the road. Driver reaction times estimates vary from 0.9 s for unexpected events with athletes as subjects (Davis et al., 1990; Schweitzer et al., 1995) to 1.6 s for 95th percentile drivers reacting to unexpected events using a more representative population (Olson & Sivak, 1986). The latter found that the 50th-percentile reaction time interval for a population of ordinary drivers confronted with an unexpected roadway obstacle was 1.1 sec, with a range of 0.81 to

1.76 s (2nd to 98th percentile). Similar results were found by van Winsum & Heino (1996) in a simulator study. It is to be noted, however, that reaction times may be shorter for more intimidating test conditions and that detection times may vary depending on the type of signal presented e.g. auditory or visual, this issue will be discussed in some depth later.

Driver reaction times become an important issue when average driver following behaviour is analysed. Wasielewski (1979) found that the average following distance for vehicles is 1,32 s, with a standard deviation of 0,5 s and a median of 1,0 s. This implies that many drivers behave such that they would be unable to successfully react and stop in a large proportion of potential rear-end crash circumstances. However, Davis et al. (1990), found that reaction time decreases as coupled vehicles i.e. those travelling relatively close together and nearly the same velocity, draw closer together. This suggests that driver attention increases in relation to how close coupled vehicles are to one another.

Methods for obtaining reaction time measures often differs between studies, each presenting a different method to determine a reaction. More research is needed investigating driver reaction to lead vehicles looming quickly with and without brake lights and driver reaction to various warning displays.

Reaction times during emergency warnings can also be influenced by the so called refractory period, in which reaction time to the second of two stimuli presented in close temporal succession might be considerably delayed (Wickens, 1992). It may be appropriate to apply the psychological refractory period phenomenon to model the effect of an emergency warning. On occasion, the driver does not pay attention to the driving task owing to the presence of an in-vehicle secondary task such as talking to a passenger or controlling the radio. Consequently, given the presence of a warning system, the driver may not always react in time to an emerging dangerous situation, thus triggering the emergency warning. The driver's reaction to the warning (the first stimulus) in this model is the awareness of the dangerous situation, or the visual stimulus of an approaching vehicle (the second stimulus) to which the driver must respond. The time interval between stimuli might be very short i.e. 500 ms. The time reaction to the second stimulus may be delayed compared to that of a simple reaction to it without the first stimulus. An emergency warning may prove beneficial by helping to focus the driver's attention on a hazardous situation, or it may prove detrimental by creating attention overload. The main prediction of the multi-stimulus model is that reaction time to the collision-warning situation may be larger than that expected from a single stimulus.

A slightly different information-processing model is required for the case in which the driver, late but surely, prepares to apply the brakes or steer to avoid a danger while an emergency warning is issued at the same time. The driver then has to interpret the warning, causing a shift in attention from action to a new stimulus. The situation may also lead to an increase in

reaction time (Horowitz & Dingus, 1992). Therefore, in assessing the design of a collision-avoidance system, timing of the warning may be critical, not only because a late warning will not allow the driver to respond in time to avoid a crash but also because an early warning may inhibit the brake-reaction response. Thus, a dangerous traffic situation coupled with an emergency warning may result in attention overload and delay in reaction, especially when there are alternative possible responses such as braking, steering or accelerating for the avoidance of the crash.

Further considerations for the design of in-vehicle warning and information systems include the attention processes involved or, more specifically, the role of attention in multitask environments. Drivers must process many sources of visual information while concurrently processing a variety of auditory and kinaesthetic signals. There are two distinct methods for allocating attention to the perceptual world: via serial or parallel processing. It is known that certain environmental conditions force the driver into a serial mode of information processing (Stokes et al., 1990; Wickens & Hollands, 2000). Simultaneously scanning the busy outside world, driving and switching to information collection from the instrument panel is one example of forced serial processing. Parallel processing also can occur while persons are driving. For example, drivers can listen to and process a radio traffic report while visually scanning the roadway environment. Moray et al. (1991), stated that a serial scanning pattern is controlled quite efficiently if the amount of scanned information sources remains small. Prioritising information importance is often observed in driver visual scanning patterns. When the driver is overloaded, less critical information receives reduced attention. Knowledge of this scanning behaviour can be utilised in effective display design by grouping important display functions and placing them closer to the primary visual task to reduce switching time. This becomes even more important in the design of systems that will inherently be viewed in high-stress, crash avoidance circumstances.

Allocation of attention to perceptual information is also affected by driver's workload level. In stressful situations, the driver will selectively scan only critical information, normally in the forward field of view while peripheral cues of reduced importance or salience are filtered out. Thus, it is possible that the cognitive capture of less critical or irrelevant information could lead to a decrease in driver performance. As more and more displays are integrated into the instrument panel area, information will get selectively filtered out as drivers become overloaded.

False alarms and warning frequency are one of the most important issues that must be dealt with in the design of warning devices. A false alarm is an alarm activation in which a device does not function as designed e.g. a sensor interpretation of ambient noise as a signal. Nuisance alarms are similar to false alarms. However, they occur when a system functions as

designed but when the situation does not constitute a true crash threat. High false-alarm rates will lead to user annoyance, resulting in a decrease in reaction performance when a true alarm is displayed. Estimates of when and how warnings should be actuated are typically based on several parameters such as reaction time. These estimates must typically be conservative to address the needs of the majority of users, which leads to higher false, and nuisance alarm rates. If the potential negative effects of warning systems in relation to the frequency of warning or “the posterior probability of a true alarm” is too low, the user loses faith in the system and deems it useless. (Horowitz & Dingus, 1992; Parasuraman et al., 1997). To overcome the paradox of providing reasonably conservative warnings while minimising false alarms, the warning concept described in section 5.3, implemented a graded sequence of warnings, a parallel change in modality (visual and acoustic) and an individualisation of warnings. These steps were intended to optimise the warning display by reducing the impact of false-alarm rates as much as possible.

As pointed out by Meyer & Bitan (2002), however, even a warning system that uses a sensitive and reliable detection algorithm, maximising the posterior probability of true alarms, and uses appropriate information presentation formats, may nevertheless be less effective than anticipated because drivers may drive differently with the system than without it. The presence and occurrence of warnings may themselves change driver behaviour. For example, a conservative warning system seeking to avoid all critical situations may be triggered frequently but the driver may react to these warnings and drive more cautiously so that false alarms are minimized. In essence, this is the antithesis of risk homeostasis conception. What is likely is that warning systems will influence driver behaviour in general, not just on those occasions when the warning is appropriate; these influences must be understood for warnings to be effective (Meyer, 2001).

3.4.2 Proposed concepts

The two methodological principles for adaptive help and instruction are outlined and the implications for the design of the two methodological concepts for learning to use ADAS are presented.

Adaptive learning environments can be designed according to two different adaptation procedures. The first procedure, macro-adaptation, is to implement some kind of offline adaptation, which means to have an open-loop, feed-forward control of the learning process. This is to externally adapt the instructions to some features of the driver which are assumed to be quite constant over time. The second procedure, micro-adaptation, is to implement some kind of online adaptation, which means to have a closed loop, feedback control of the learning process. This is to internally adapt the instruction to some features of the driver which change moment-by-moment. Learning environments with offline adaptation may be called adaptable, those with online adaptation may be called adaptive (Leutner, 2003).

In the vehicle, drivers are often confronted with relatively complex systems with no prior explanations of how they work. The drivers task is to figure out how the system works. Thus drivers have to acquire knowledge of the system in which the relevant information is not given explicitly. To the contrary, the information is implicit, and has to be made explicit by some skilful exploration behaviour. The safety-critical nature of ADAS make such explorations precarious. When drivers are confronted with ADAS, in a discovery learning setting, exploratory actions may have irreversible consequences. Further, it is known from the domain of computer simulations, that learners have great problems in exploratory learning (Kröner, 2001; Süß, 1996). As a result, they tend to miss important information and, when they have to make decisions, the decisions are false or less effective.

A micro-adaptation approach was designed to compensate these deficits by automatically advising drivers when they repeatedly show false decisions, helping to operate the system more effectively and to acquire knowledge of the system's functionality and limits. The idea is to initialise the mental model of ACC via information about its interface, its functionality and its operational limitations. Then, as interaction, exposure and experience shape the mental model of ACC, adaptive feedback is used to help update the various components of the mental model.

For example, dependent on the situation, drivers received: warnings e.g. "in a similarly tight curve, the car in front might no longer be detected by the ACC"; corrections, e.g. "the vehicle in front is braking hard-ACC may not be able to compensate for the high deceleration...ACC could have managed here" or "the speed set by the resume button was lower than the actual speed-in this case, pressing the +/- would have been more effective"; reinforcement, e.g. "it was important that you intervened-the braking capacity of the ACC system was not sufficient"; and elaborate comments on events e.g. "the +/- button takes over the last selected speed-this is indicated with a green LED in the speedometer". Furthermore, drivers were dynamically made aware of using the tutor system with a display in the speedometer.

Focusing on computer-assisted instructional systems, forms of intelligent tutoring systems (ITS), like the one mentioned above, seem to represent a rather high road of implementing adaptation principles in the vehicle. An ITS is constructed based on principles of artificial intelligence and can be characterised by having three basic components: 1) a monitoring module which is able to detect traffic situations and environmental conditions, 2) a diagnosis module which is able to learn from the learner, and 3) a tutor module which is able to generate instructional feedback and explanations. Up to now, however, only a very limited number of ITS have successfully been developed for very specific and restricted domains of knowledge (Leutner, 2003).

One of the most important design problems for information systems, is to decide how much feedback and advice is needed in order to reach a given goal. Especially in situations of self-regulated learning, it is known on the one hand, that many drivers over-estimate their level of knowledge and skill (Groeger & Grande, 1996; Guerin, 1994). As a consequence, drivers might turn off the feedback and advice from the tutor module before they have really reached the goal of learning. As a result, they might not be able to use the system optimally or predict the system's limits. On the other hand, we know that a reasonable amount of drivers tend to underestimate their level of skill (Groeger, 2000). As a consequence, drivers might keep listening to all feedback and advice from the tutor module and over-learning the system to a large and unnecessary degree. As a result, they will achieve an optimal use of it but will probably have suffered irritation in the process. Obviously, this is a problem in self-regulated learning. However, it is also a problem in situations in which external agents in the learning environment try to control driver's learning processes.

In the second concept to learn to drive using ADAS, it was thought that drivers would learn best when the timing of the feedback was individually allocated. A macro-approach was developed and evaluated in order to reduce deficits in predicting the system's limits and to develop the appropriate sensitivity of response. This approach differed in that feedback was appropriated in relation to a feature of the driver which is assumed to be quite constant over time: their reference for comfortable decelerations and subjective risk. Drivers references for comfortable decelerations and subjective risk were measured before he or she started discovery learning. The measures were based on drivers' maximum preferred braking preference and minimum allowable distance to the lead vehicle.

The system was designed to have a relatively benign cautionary alarm, which will warn the driver when his/ her preferred personal acceptable braking force (time reserve) will be exceeded in order to maintain his/ her minimum allowable distance. The idea is that an individually adapted cautionary alarm, matched to drivers individual preferred braking decision thresholds would not only provide information about the level of the danger as the driver approaches a vehicle but also provide an early signal of intuitive value in terms of the necessary response which will help drivers integrate the system into their own driving style, thus increasing drivers comfort and efficiency. For example, in an approach situation, if a drivers personal, preferred braking force was high, the warning would be emitted reasonably late, if the drivers preferred braking force was low, an early warning was emitted. Additionally, the criticality of the situation was displayed in a dynamic display in which the looming effect was depicted by a change in the size, the colour and the luminosity of a vehicle symbol in the speedometer.

Drivers acquisition of skill was further helped by adjusting the warning signal in accordance to the driver's general cognitive abilities. As opposed to standard measures such as time

headway (TH), which is known to be difficult for drivers to judge, or time-to-collision (TTC), which demands predicting future states of the system, drivers are informed of the moment in which their preferred deceleration level will be exceeded in order to follow the lead car with a preferred distance—two driver-selected measures which are intuitive and, if impinged on will directly be noticeable to drivers, thus having the capability of decreasing both driver complacency and annoyance. Following the cautionary alarm is a more threatening imminent alarm signalling that an immediate brake-reaction was required with drivers maximum personal deceleration. Figure 5 shows a taxonomy classification of the various feedback presentation approaches that have been proposed for ACC systems.

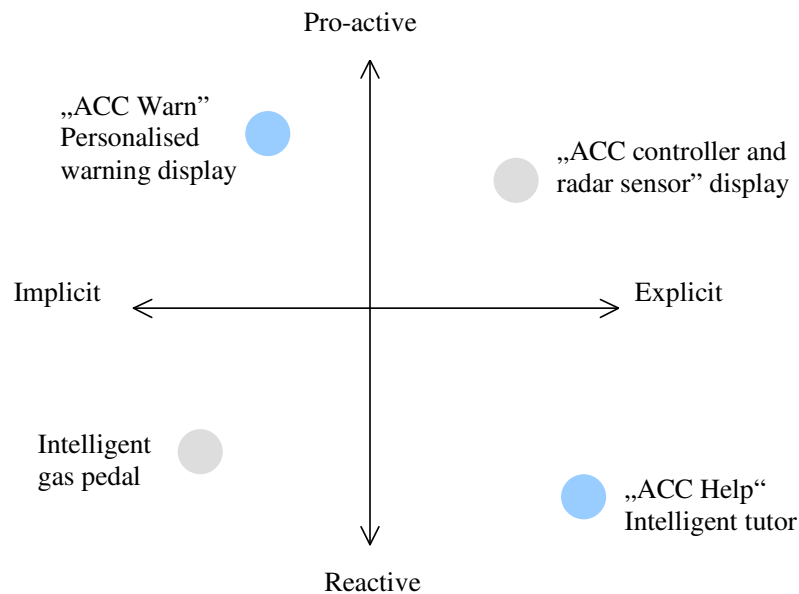

Figure 5. Taxonomy of feedback presentation approaches for an ACC system

The intelligent tutoring approach is reactive, in the sense that the information and help emitted is based on the analysis of drivers' behaviours. The feedback emitted is explicit, pinpointing the problem and explaining the solution. In contrast, the personally adapted warning system is an approach which is pro-active, with a feed-forward control of the learning process. The information from the system is implicit, requiring interpretation of the warning display to learn how and when to intervene in take-over situations. These represent new approaches to learning to drive with ACC. Past approaches to improve interactions with ACC systems have been marked in grey in the taxonomy. On the one hand, an intelligent interface for learning correct responses to take-over situations was the implementation of an 'intelligent' gas pedal (Chaloupka et al., 1998; Godthelp & Schumann, 1991; Hogema et al., 1994; van der Hulst, 1999). Advice was triggered by the ACC system's sensor when, for example, a vehicle ahead was moving at a lower speed. The drivers' foot needed to rest on the pedal which would apply a force against the driver's foot. The haptic feedback helped drivers

learn the system's limits, similarly requiring driver interpretation. On the other hand, to help drivers understand the functioning of the ACC controller and radar sensor, visual displays were implemented on an additional in-vehicle monitors (Brookhuis & De Waard, 1999; Comte & Jamson, 1998; Hogema et al., 1995), which showed, for example, the range and scope of the sensor (Praxenthaler, 1999). These approaches, however, showed only limited improvements in drivers behaviour.

Learning in an open environment, in which the driver decides by him or herself when, where, when and what to learn, is nothing else than a special case of self-regulated learning, and it is to be expected that many learners, due to their low learning ability in such a learning environments, will require some help. As a solution to this problem, the suggestion was to design adaptive learning environments, which can be adapted or which adapt themselves to the need of the driver. Two experimental studies will investigate the impact of these concepts on the acquisition of knowledge and skill through drivers driving behaviour and interaction with the ACC system.

3.5 Conclusions and central hypotheses in the thesis

The automation of any task raises a plethora of psychological issues. Automation of part of the driving task similarly requires the need to properly address these issues to improve interactions within the human-machine system. The recapitulated up-to-date research on ACC shows that the main psychological issues in Stanton & Young's (2000) proposed psychological model of driving automation have been addressed. Automating the driving task, for example, has been shown to reduce physical and mental workload (Fancher & Ervin, 1998; Risser & Lehner, 1997; Stanton et al., 1997; Stanton & Young, 1998; Winner et al., 1996) and have a positive influence on the flow of traffic by helping to keep the speed and distances of vehicles more constant over time (Fancher et al., 1998). Other facets involving the use of the ACC system including mental models, situation awareness, locus of control and trust, however, yielded less positive results. When considering the effects of automation, studies have found that recovery of the vehicle was better when drivers had full manual control (Desmond et al., 1998; Gugerty, 1997; Stanton et al., 1997). Nilsson (1995) suggested that drivers using ACC had greater expectations about what the system could cope with, which was at odds with what it could actually do. Moreover, drivers became complacent and over-reliant on the technology, an aspect of automation which has been well established in other domains (Parasuraman, 2000; Parasuraman & Riley, 1997; Reason, 1992).

Of particular importance in the flow of information between the parts of the human-machine system is the issue of feedback. Typically, feedback to the driver from the automated system

tends to be poor because the automated systems do not require the feedback to function. The content of feedback can be about system actions and / or responses. Or it can be simply registering a user's input. Either way, it was widely found that feedback is instrumental in skill acquisition (Anderson et al., 2001; Schmidt & Lee, 1999), particularly in its early stages when tasks still require controlled processing (Groeger, 1997). Norman (1990a) specifically refers to the insufficiency in feedback as a major contributing factor to the problems of task automation. Muir & Morray (1996) further contend that the development of the driver's trust in the automated system depends upon appropriate feedback.

In previous studies, this central issue has largely been addressed by adding visual or haptic information to the ACC HMI (Chaloupka et al., 1998; Godthelp & Schumann, 1991; Hogema et al., 1994; Praxenthaler, 1999), however, so far, little improvement in drivers' interactions resulted. Feedback has been presented in different modalities and both in reactive and proactive forms. Adaptation of feedback, either to an individual feature of the driver that is quite constant over time or to some features of the driver which change moment-by-moment i.e. their system knowledge, present new and promising methods for achieving continual feedback and interaction with the system to keep drivers in the loop and improve system interactions.

This work investigates the relationship between individual learning requirements when learning to drive with an ACC system and the influence of embedded intelligent help systems on drivers' behaviour. The central hypothesis is that by responding to the difficulties met by users in the actual situation and by adapting the information to the drivers' experience, or personalising feedback to a driver-specific characteristic, drivers' learning progress can be accelerated through better comprehensibility and predictability of the system. To this aim, a three-step research strategy was developed

First, an in-depth analysis of a long-term field study was undertaken to explore the main difficulties users experienced during ACC driving. From the long-term driver interactions with the system, 'real data' could be extracted on drivers' approach strategies to the system. A further aim of the study was to assess the extent of the encountered difficulties and define a set of learning aims, upon which drivers' performance and learning stage could be measured. As opposed to most ACC studies that have concentrated on one aspect of interaction, the data analysis covered each level of the driving task (see section 2.2.3). The analysis was backed up by questionnaire and interview measurements.

The study was conducted to help find ways in which the interaction between humans and ADAS in future could be improved. Thus, particular attention was paid to the decisions and actions taken by novice and more experienced users when confronted with particular situations as well as the process of arriving at efficient system usage. It was predicted that the

type of decisions and actions taken by a novice and a more experienced user when confronted with particular situations would differ and that contextual difficulties experienced by users were due to a lack of feedback from the system.

Second, a driving simulator study was conducted. The experiment's aim was to investigate the effects of contextual and adaptive feedback on system interactions in the learning phase. To this aim, an embedded intelligent tutoring approach was taken. Following the cognitive apprenticeship theoretical framework (Cognition and Technology Group at Vanderbilt, 1993; Collins et al., 1989), it was hypothesized that making knowledge of the system explicit would enable participants to gain a quicker implicit understanding of the system.

Cognitive apprenticeship methods were also used for contextual feedback. The embedded tutor system situated learning, by anchoring feedback to situations. It was predicted that by embedding the learning of knowledge and skill in its functional context, the use of the system in less-than-optimum conditions would be minimised, that the number of operational errors would be reduced and that more appropriate and timely decisions to reclaim control of the system could be achieved.

Learning in open environments is known to be problematic due to people's low learning ability in such learning environments (Groeger & Grande, 1996; Guerin, 1994; Kröner, 2001; Süß, 1996). In learning to drive with ADAS, cognitive apprenticeship provided a learning framework which supports self-paced learning by offering help when it is required. The core teaching methods of the cognitive apprenticeship method—modelling, coaching and fading—provided the basis for the appropriate amount of information to be given dependent on the learning stage of the driver.

As opposed to immediate notification of the un/successful completion of an action, or action feedback, learning feedback was given. This type of feedback was more in-depth knowledge of the drivers' performance which is typically given through tuition (Anderson et al., 1995). By registering the user's input, the tutor could attribute explicit individualised advice and provide reactive feedback. As opposed to the visual and haptic feedback canals, the tutor used acoustic feedback to give explicit, contextual and timely advice. It was predicted that where experience is required to learn a set of condition-action rules to the system's limits, drivers would benefit from getting in-depth knowledge of the system's actions and responses as well as from their own performance.

Situated, explicit feedback, therefore, was predicted to help drivers achieve more effective interaction on each level of the driving task. From learn adaptive feedback, drivers were predicted to achieve this quicker. Feedback was adapted to individual performance in context as well as to previous experience of the system. This form of micro-adaptation (Leutner, 2003) enabled a closed-loop feedback control of the learning process, enabling users to update

their system image more frequently in order to gain a more comprehensive, accurate model of the system more rapidly (Bainbridge, 1992; Moray, 1999). By accelerating the cognitive learning phase therefore, it was assumed that learners could progress towards what Anderson (Anderson, 1993) has described as proceduralisation or the acquisition of skill.

Third, a second simulator study was conducted. This study investigated the effects of adapted feedback on drivers' interaction with the system in the learning phase. This approach differed to the first simulator study in that feedback was appropriated in relation to a feature of the driver which is assumed to be quite constant overtime: their reference for comfortable decelerations and subjective risk. This approach is akin to what Leutner (2003) has described as macro-adaptation.

As opposed to the investigation in the first driving simulator study, the focus of this study was on the most learn-intensive and safety critical aspects of interaction: the task of reclaiming control of the system when the automated system limits are reached. These situations typically require quick reaction times when drivers workload is high (De Ward et al., 1999; Mayser et al., 2003; Stanton et al., 1997; Young & Stanton, 1997). It is predicted that in these situations drivers' response criterion is dependent not only on learning, i.e. getting used to the system and being more comfortable with predicting the systems' behaviour over time, but also on an individual 'threshold', based upon an internal reference which can be adjusted, especially in the learning phase, by targeted information. It is argued that feedback timing is more crucial than feedback specificity in situations demanding rapid decision-making and response times.

The embedded intelligent system in the second simulator study was a personalised ACC multi-level warning system. Feedback was pro-active, informing drivers of potentially critical situations through a graded warning display. As opposed to single warning systems, the human-centred ACC warning was combined with a collision alarm to achieve the correct balance of warning sensitivity and intrusiveness (Horowitz & Dingus, 1992; Parasuraman et al., 1997). The relatively benign cautionary warning was adapted to drivers' preferred personal deceleration. A graded warning signalled situations in which the driver's level of accepted subjective risk, or level of risk homeostasis could be exceeded (Wilde, 1994). This was predicted to offer considerable advantages over the system-centred warning design of current ACC systems. As opposed to time headway information, which is difficult for drivers to judge (Dingus et al., 1998; Taieb-Maimon & Shinar, 2001; van Winsum & Heino, 1996) or time-to-collision, which demands predicting future states of the systems (Hoffman & Mortimer, 1994; Manser & Hancock, 1996; Tresilian, 1995), the warning signal is in accordance to drivers' cognitive ability. Drivers are informed of the moment in which their preferred deceleration level will be exceeded in order to follow the lead vehicle with a

preferred distance. It is predicted that these personalized measures are intuitive for the drivers and which, according to motivational models of drivers' risk handling and threat avoidance (Fuller, 1984; Summala, 1988; Wilde, 1994), if impinged on will directly be noticeable to drivers. Thus, a personally adjusted display aimed to help drivers predict the need to intervene. The information at this level was not intrusive. It was visually displayed using what has been termed as the 'looming effect' (Smith et al., 2001). Implicit learning based on the individual sensitivity of the situation's criticality aimed to help drivers apply the adequate braking force in take-over situations.

The second level warning was a collision alarm. Similarly, the alarm was based on a measure of time. The time-reserve (Kopf, 1994) signalled that an immediate brake-reaction was required with drivers' individually defined maximum personal deceleration. Pro-active feed forward from the multi-level design and complete adaptation of warnings to drivers' perceived risk and deceleration preference was predicted to decrease both driver complacency (Evans, 1991; Meyer & Bitan, 2002) and annoyance (Meyer, 2001; Stanton & Edworthy, 1999).

Drivers' ability to perform additional tasks beside the task to learn was used as a further criteria for the learning progress in take-over situations. Drivers' resources needed to predict and reclaim control of the system was measured using the PDT (Baumann et al., 2003; Martens & van Winsum, 2000; Olsson & Burns, 2000) methodology to measure peaks in workload. It was predicted that drivers will require less resources during take-over situations when the ability to make accurate predictions of the necessity for interventions has been acquired.

4 METHODOLOGIES FOR EVALUATION OF ADAS

4.1 Field studies

Various methodologies are available for the evaluation of ADAS on system interactions. Particularly for research into ADAS, as the numerous citations of empirical research show, field studies often represent the methodology of choice. Despite their drawbacks (cost, accident risk and environmental dependence) this methodology is often chosen as results from these studies usually imply a higher external validity (Nilsson, 1993). However, even in the framework of field studies, the question of external validity merits closer consideration. Test drives often represent exceptional circumstances that are not necessarily marked by a high validity only because they were undertaken on public roads. Moreover, the use of experimental vehicles and equipment prototypes affect participants' driving behaviour. The difficulties in standardising traffic situations, which is necessary for a founded analysis of the collected data presents a fundamental problem of this method.

The un-scaled and usually undefined (or imprecisely defined) traffic situations add to the unstructured occurrences of condition factors, as is usually the case in field studies, which often prevents a systematic assessment definition. Further, a considerable problem is brought about by the noise created by the variance in the different measurements used. For field studies to be of value, especially when used as an end-evaluation, a series of control conditions must be achieved that demand considerable effort and expense.

After handing over the vehicle to a participant, an introductory drive for him/ her to get accustomed to the vehicle settings is important. If only a specific procedural task is to be tested, a supplementary training phase would be required to help control confounding variables and reduce variance problems in operational errors, which would inevitably increase the time required as well as the costs. Adequate planning of the itinerary and timing of the test drives ensures initial conditions for the clarification of validation problems. As in simulation studies, however, this demands considerable time and effort.

4.2 Driving simulator

The BMW fixed-base driving simulator has been developed to allow for early development of new systems e.g. ACC (Bernasch & Haenel, 1995) and evaluations of their components (Praxenthaler, 1999). The experimental studies were aimed at studying the effects of different forms of intelligent help-systems on drivers learning behaviour during interaction with the

ACC system. The simulation gives the possibility to conduct reproducible tests, in the absence of safety risks while enabling the measurement of aspects related to the ACC itself as well as to driver workload and other aspects of the interaction with the ACC system.

The cockpit consists of a car cabin, which is the forward half of a BMW 520i with all the original controls related to the driving task per se i.e. steering wheel, accelerator, brake and clutch pedals, automatic gear shift, seat adjustment controls etc. The entire dashboard, including the center stack, middle console (including the on-board monitor) and speedometers were all 7-series fittings, see Figure 6.



Figure 6. Five series mock-up in BMW driving simulator

The adapted vehicles used in the driving simulator are linked via the standard CAN-Bus interface with the simulation computer. This simplifies the change of vehicle mock-up and saves time and effort in dismantling and remantling new mock-ups. The set-up shown in Figure 7 was used for the studies conducted.

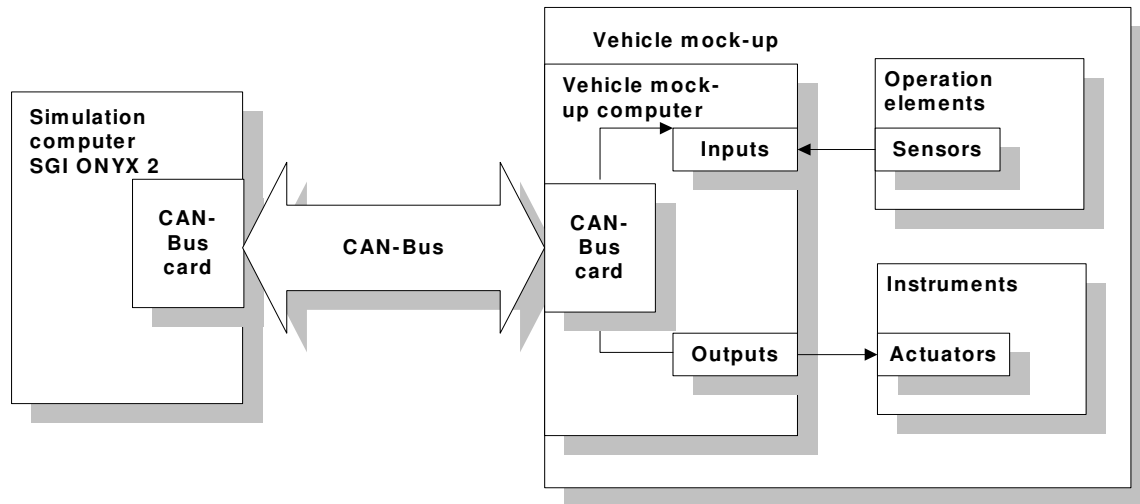

Figure 7. Set-up of the BMW driving simulator

Every vehicle mock-up is equipped with a PC containing a CAN-Bus interface and measurement cards to measure the various parameters such as the accelerator pedal position or the steering wheel angle. The measured data are processed and sent via the CAN-Bus to the simulation computer. The feedback signal runs on a separate computer, which projects driver relevant information such as driving speed and motor revolutions onto the centre display. This allows for a flexible representation of the in-car displays and a free choice of display dependent on the study to be performed. The simulation computer used was a Silicon Graphics graphic workstation ONYX2, equipped with twelve processors and a CAN interface card. It computes the driving dynamics and the graphic card for the external view. Moreover, it records the driving specific data and generates the driving noise. The steering wheel torque in the driving simulator is produced by an electric motor, which is coupled with the steering wheel column.

For the simulation of the external view, two alternatives exist. The simulation can either be projected by three wall-mounted projectors onto a cylindrical canvas screen, which enables the coverage of a horizontal angle of 190° or be presented on six plasma screens positioned in a semi circle at the front and at the rear of the vehicle. This second variation is able to cover a horizontal angle of approximately 120° . The disadvantage of this variation is that the overlapping of the screens brakes-up the external view (due to the plasma screen frames). The high contrast and picture sharpness amongst others, however, allows for a more realistic representation of the scenery. The simulation of the rear view is achieved by using three plasma screens. The view from the central rear-view mirror or from any of the two side mirrors shows the exterior view without a disturbing frame. The picture refresh rate was 60 Hz with a resolution of 1280x1024 pixel and a colour depth of 24 bit. Loudspeakers positioned in front and behind the drivers seating position emit the generated background noise.

Due to the driving simulator's modular construction, it is relatively easy to integrate new concepts (Huesmann et al., 2003). The graphical user interface simplifies the configuration of the system for the user. The modular set-up of the driving simulator software allows supplementary functions such as those of the multi-modal tutor system to be integrated.

The driving simulator allows the driver to move freely in a network of roads with signs, buildings and road traffic as if driving in the real world. A number of test tracks are available on which a great number of traffic scenarios can be programmed. Dependent on these traffic scenarios, traffic lights can be altered for example, or even the behaviour of other traffic users.

A scenario specification language defines interactive traffic participants and their individual actions within a specified road environment. The simulated vehicles move autonomously through the perceived environment while attempting to establish their individual goals. They do this by evaluating a set of behavioural rules that lead to appropriate manoeuvring decisions and corresponding actions for which a descriptive model of human driving is used. The simulated vehicle in which the driver sits is considered by all other vehicles as just another road user and interacts with it as they do with all other vehicles. This natural interactive behaviour between 'intelligent' vehicles creates a very realistic environment in which drivers perceive other vehicles as real traffic participants (Hochstadter et al., 2001; Strobl et al., 2000). However, since the simulator is fixed based, the driver lacks the locomotion sensations experienced in real driving. For some drivers, this discrepancy between visual movements and locomotion standstill can lead to nausea or 'simulator sickness'.

4.2.1 Simulator validation issues

There are many reasons to use driving simulators in traffic behaviour research. An important advantage of simulators is that they allow driving conditions and environmental conditions to be kept constant. All subjects participating in a study can be exposed to exactly the same conditions. In field experiments, it is obvious that the factors that influence driver behaviour (except those studied) are usually too many and too unpredictable to be appropriately controlled. Moreover, interactions between the factors can make the interpretation of results from field studies very difficult. Therefore, driving simulators are well suited for comparative effect studies where one or a couple of factors are systematically varied, while all other factors are kept constant. Since the environmental and driving conditions can be kept constant in a simulator, the required number of subjects can be much smaller compared to field studies without losing statistical power. Also, data collection in experimental situations is greatly facilitated by the simulator since all relevant performance measures are continuously available. Another advantage of driving simulators is that they allow the testing of drivers unsafe and risky driving behaviour, which could potentially have catastrophic consequences (Carsten et al., 1997). Especially important for the testing of critical situations, the simulator

environment provides the possibility to analyse drivers' responses and manoeuvres too dangerous to be tested in real world driving. Relatedly, it is possible in driving simulators to collect data on a whole range of situations unlikely to be encountered in the natural environment in a short time frame. In the light of the modern information technology to support drivers in their task, another advantage with simulators is the possibility to test and evaluate proposed in-vehicle systems during the conceptual phase of the development (Ehmanns et al., 2000; Nilsson, 1993).

Simulator studies have many advantages but real driving on streets is not fully substituted by simulator technology today. A problem with most driving simulators is that drivers experience a lack of correspondence between visual and motion information, which can lead to uncertainty and abnormal behaviour. These limitations are most likely to appear in experiments that contain many sharp bends and that require fast manoeuvres (Jamson, 1999). Validity tests are required in order to prove that driving behaviour in a simulator is realistic. Validity tests involve the comparison of driving behaviour in a driving simulator and driving behaviour in an instrumented vehicle. For simulator driving, absolute and relative validity are distinguished. Absolute validity refers to the numerical correspondence between behaviour data in the driving simulator and in the real situation, whereas relative validity refers to the direction or relative size of the effects of the measure in relation to effects in the real situation. For a driving simulator to be useful as a research tool it is necessary that relative validity is satisfactory, that is that at least similar effects are obtained in both situations. Absolute validity is not a necessary requirement since research questions almost uniquely deal with matters relating to effects of various independent variables (Törnros et al., 1997).

In a survey of several validation studies, Kaptein et al. (1996) showed that there are limitations in the validity of a fixed-base driving simulator in assessing driving behaviour. The results generally had relative validity but no absolute validity. In the validation of fixed-base driving simulator Blana & Golias (1999) found, for example, that subjects generally drove at higher speeds and had a larger standard deviation of the lateral position in the simulator but that the experimental effects were in the same direction as driving on the real road. The differences in absolute level of driving speed and standard deviation of the lateral position were related to the lack of proprioceptive information and the small amount of visual information. Godley et al. (1997) carried out two experiments to validate their fixed-base simulator. Speed and braking actions were found to be highly correlated between the on-road and simulator experiments. Deceleration, however, did not result in a strong validation, which, they concluded, may be due to the lack of horizontal motion cues associated with real-life braking but lacking in the simulator.

Movement fidelity is possible with moving-base simulators. Some argue that lack of movement detracts from the generalisability of data from driver simulators. In their

comparison of ACC driving and situations in which drivers had to reclaim control of the ACC system from studies conducted in fixed-base and moving-base driving simulators, Stanton & Young (1998) found that results from the moving-base simulator were comparable to those from the fixed-base simulator. This suggests that the data from the fixed-base simulator may be equally valid.

In the experiments performed in the context of this thesis, the perception of TTC plays an important role. In the studies described in section 3.3.2, strong support for the idea that TTC information is extracted from the optic flow field was given. An important pre-requisite for a smooth optic expansion is a high graphical frame rate which has been achieved in the BMW simulator through the use of plasma screens for the projection of the front and rear scenery. Since the graphical properties of optical perspective, visual angle and optical expansion rate are the same in the BMW simulator as in real world driving, there is reason to assume that the driving simulator is suitable for analysing driver interactions with the ACC system.

Although De Waard & Brookhuis (1997) found that the amount of effort subjects put into driving in a simulator, as measured by the Rating Scale Mental Effort (RSME), is much higher compared to driving in a real car, many studies have concluded that driving simulators can provide accurate observations in workload peaks as compared to real world driving (Bengler et al., 2003; De Waard & Rothengatter, 1998; Krüger et al., 2000; Martens & van Winsum, 2000; Olsson & Burns, 2000; Wooldridge et al., 2000).

A European research program called HASTE (Human Machine Interface And the Safety of Traffic in Europe) has begun to address how to perform collaborative studies on different simulator platforms by providing a repertoire of strict definitions of driving performance and workload measures in order to assure their comparability. However, the definitions still leave room for discrepancies concerning data recording, filtering and other data processing, emphasising the need for stringent reporting of how data has been collected and processed (HASTE, 2003).

The general conclusion may be drawn that a driving simulator is a valid instrument to study driving behaviour, as long as the set of cues important to the investigated aspect of driving, is available in the simulator. Further, it should be kept in mind that it is only meaningful to draw conclusions on the relative effect size. Bengler (1995) summarises the advantages and disadvantages of the field and simulator instrumental measurement methods as follows:

Table 3. *Summary of the comparison between field and simulator experimental methods*

	Field study	Simulator study
Detail of representation	++	++
Traffic	++	++
Standardisation	--	++

Measurements	+/-	++
Cost	-	++
Time expenditure	--	-
Safety	--	++
Flexibility	--	--
Vehicle model	++	-
Reactivity	++	-
Visual angle	++	--

4.3 Subjective measures

Questionnaires were administered as a complementary subjective assessment after the long-term study and after each drive, to acquire attitudinal aspects of the ACC and of the intelligent help-systems. The type of rating scale were Likert-type scales as they offer a reliable, rough ordering of participants with regard to a particular attitude. Further, Likert scales have a better acceptance as respondents usually prefer this to a simple agree / disagree response, and provide more precise information about the respondent's degree of agreement or disagreement. The reverse side of the coin is since the scale offers no metric or interval measures and lacks a neutral point, the scores in the middle ranges change can range from mildly positive to mildly negative. Moreover, scores in the middle region could be due to lukewarm response, lack of knowledge or lack of attitude in the respondent, or to the presence of both strongly positive and strongly negative responses which would more or less balance each other (Oppenheim, 1992).

Another method used for eliciting drivers subjective impressions was interviews. Interviews were conducted following the long-term study to get a more detailed understanding of drivers feelings of comfort, safety and trust, as well as on their expectations and their requirements for additional information.

The advantage of interviews lies in the possibility to ask numerous open-ended questions, or open-ended probes and record verbatim the answers given by the respondents. Open-ended questions were used to allow the respondents to say what they think and to do so with greater richness and spontaneity. It was thought that by actually seeing and talking to the participants and confronting them with their own responses to the system, a better picture could be made of their general attitudes and understanding of the system.

The disadvantages of using interviews are to some extent a reflection of the advantages. Obviously, interviews are much more expensive than questionnaires. The larger or more dispersed the sample, the greater the total cost of the interviewing operation. The cost factor

also enters the data-processing stage since interviews are used particularly where many open-ended questions have to be asked, there will be a lengthy coding process i.e. developing and using classifications for the answers to each question. When conducting interviews, bias is probably the largest source of error. Thus, the interviewer should strive towards obtaining data that are 'uncontaminated' by the interviewing process and the classification of answers at the data-processing stage should include at least one additional independent interpreter.

5 EXPLORATIVE STUDY

5.1 Field study – Long-term ACC system usage

5.1.1 Introduction

As a point of departure for the conception of approaches toward reducing the learning phase associated with the system, a thorough understanding of the usage and potential difficulties of usage was established. To gain a thorough understanding of the interactions at play during the use of ACC, an extensive analysis of “free ACC driving” over a long-term period was executed. The first three weeks of usage was analysed after participants had been introduced to the system and handed over the test vehicle. During this early usage period, the analysis focused on the way in which participants made use of the system in different traffic, road and weather conditions. The analysis was based on uncovering aspects related to the operation of the system, reactions to system limits and use in varying environmental conditions that represent a hurdle in learning to use the system. The exploratory nature of the study aimed to build a complete picture of the way in which users interact with the system and how, over time, interactions changed as experience with the system increases. Thus, from the analysis of participants interactions, together with the administered interviews and questionnaires, the study aimed to extract the learning hurdles as well as the learning aims towards driving with ADAS. Learning aims are understood here as being “the achievement of an efficient and errorless behaviour at the end of the learning process, for the dimensions of interaction with the system for which learning must be effectuated by the driver”. Uncovering the learning hurdles in all aspects of drivers’ interactions with the system will help design a system capable of ameliorating and quickening the acquisition of knowledge and the development of skill, whereas, the derived learning aims can serve as measurements for the effective and safe usage of the system.

Participants’ contact with the ACC system will, at first, be getting to know the system. This is likely to be carried out by testing the system’s main functions, usually on a trial basis in non-threatening conditions, such as, for example, an empty motorway or on a familiar road. This formed the analysis of the basic system operations (in specific situations as well as in the system’s different modes). In terms of observable behavioural characteristics, the main measurable parameters were the system activation and de-activation. This includes the way in which the system is operated i.e. how the system is activated or de-activated or learning in which situations the system should be turned off. The frequency of operational errors was

measured. It was expected that the number of operational errors would fall over the usage period.

Drivers might then begin to explore optional settings at the operational level i.e. the usage depth of the system's possibilities (i.e. different following distance settings). Optional parameters such as time-headway (TH) need more time before they are fully integrated into the user's model of the system. Changes in the selection of the desired 'time headway' (TH) was analysed in respect to adverse conditions, changing traffic quality and road types. It was hypothesised that drivers would adjust their TH according to visibility, time of day or adverse weather. In terms of differences between drivers, it was expected that drivers would adopt their preferred TH from the available range (i.e. very sporty or very cautious drivers will select both extremes of available TH).

After continued use, drivers will begin to apply their acquired knowledge to different circumstances. Having made considerable use of the system's standard and optional functions, drivers might experiment by testing the system's functionalities in less familiar situations. They might begin to turn the system on more frequently although they will also be confronted with limits of the systems e.g. ACC acceleration upon exiting the motorway.

Drivers' mental model will develop into a more detailed one. Trust in the system's functionality will grow, although the time it takes will often depend on the encountered critical situations and drivers' attitudes towards them. Situations in which the limits of the system are reached represent extreme but relatively rare events to which the driver must be alert and be ready to anticipate. The reactions to these situations are learned reactions, which are often the result of associations between the eliciting conditions and the actions they require. Through time and repetition of these situations, drivers' reactions will become more 'automatic', effortless and consistent. Following extended usage, a casual and intuitive usage of the system might take over. The usage of the system would then need little extra concentration as the driver has accumulated a broad experience of the system limits. Very few operational errors will be committed as the situations the system can handle are known as well as the reasons in the eventuality of a system's unavailability or faulty reaction.

Drivers' interventions in these situations require high attentional requirements, rapid processing of information and decision-making in what is often a very limited time-frame. For the analysis of these sometimes critical take-over situations, they were categorised into the type of situation limit it is in terms of the learning to be effectuated and closely analysed through the use of video analysis to determine the exact conditions and speculate on the reasons of the intervention. Time to intervention (TTI) was then determined on the time the driver took before intervening from the moment a vehicle had come into the ACC system radars' field. It was hypothesised that the number of situations in which drivers' intervention times are longer will increase over time as drivers learn the system limits and gain trust in the system. If this hypothesis is accepted, the 'criticality' of situations in which system limits are

reached will decrease and thus a reduction in the number of 'panic' or hard braking with a corresponding increase in the number of moderate braking and manual system de-activations should be observable.

5.1.2 Methodology

5.1.2.1 Scope of the study

The long-term usage of ACC study was commissioned to the Fraunhofer Institute Verkehrs- und Infrastruktursysteme by the BMW Group. The study was divided into three parts. The first and last part involved a three-hour drive on the BMW test track in Aschheim. The first part aimed to test fatigue and vigilance during ACC and normal driving. The third part analysed drivers' behaviour before the use of ACC and after an extended period of ACC driving. A detailed description of the operational test sequence is given by Nirschl & Blum (1999).

The second part consisted of an explorative study of the usage of ACC in which over 15,000 kilometres were driven over a four month period. The data recorded for the analysis included the car data as well as the operational, environment and video data. In the framework of this thesis, the data was re-analysed in terms of the operational usage of the system and application range (dependent on type of road and weather conditions) as well as with regards to participant's learning of the system's functionalities (dependent on system status or the environment) and limits based on the changes in their behavioural interactions. Additionally, subjective data measured by means of questionnaires and supplemented by follow-up interviews was analysed.

5.1.2.2 Participants

Five participants took part in the study. Participants were selected from private and professional contacts of the commissioned. The most important pre-condition for selection was that the participants had no experience of ACC driving. Another important consideration was good communication skills. The participants were aged between 28 and 52 ($M = 43$). All participants were currently employed and had a wide range of professions (medical technician, wholesale advisor, insurance broker and two physicists). All participants owned a vehicle and drove on a daily basis. The types of vehicle owned ranged from a Mercedes E220 and Audi A4 to a Nissan Sunny. One participant drove a 520i BMW. Participants drove yearly between 10 and 90.000 kilometres ($M = 43,000$ km).

5.1.2.4 Apparatus

The study vehicle

The vehicle used for the study involved an automatic BMW touring 525tds. Additional features were a GPS system (Philips Carin) and a hands-free in-car telephone (Nokia 6081). The technical systems in the car were conceived in a way that the driver would not have to do anything in relation to the system. Turning the ignition on would automatically start all the systems related to the ACC system and to the recording of the data. After turning the ignition off, the system remains active a further 30 sec. in which time the necessary shutdown processes are carried out. The driver, however, need not pay any attention to the functioning of the systems.

The ACC System

The vehicle used for the study was fitted with an ACC system similar to the models used in series vehicles. It comprised of the following characteristics:

- Radar sensor ODIN
- Sensor distance range: 150m
- Functional limits: 30mk/h – 160km/h
- Limited maximum programmed braking capacity: $-1,6\text{m/s}^2$

All the ACC related functions are operational through the knobs integrated in the multifunction steering wheel (Figure 8).



Figure 8. Functions in the Multi-Function Steering wheel (MFS)

The knobs in the MFS had different functions depending on the ACC system status. When the system was off, either of the “+/-“ buttons could activate the system, in which case the system would be set to the actual driven speed. The ACC system could also be activated with the “resume” button, in which case the previous selected speed (before the system was deactivated) would be set as the desired speed.

The “I/O” button de-activates the system. It may also be de-activated by applying the brake pedal and will do so automatically if the actual speed goes below 30km/h.

When the system is activated, the “+/-“ buttons respectively increase or decrease the desired speed in 10km/h increments. In this status, the “resume” button serves to select the desired distance to the preceding vehicle. The driver may choose between four distances: 1,0s; 1,3s; 1,6s and 1,9s. By the first press of the button, the actual selected desired distance is displayed in the vehicles’ board monitor. Each further press of the button selects the next desired distance.

Displays were implemented both in the board monitor below the speedometer and the revolution counter as well as in the increments of the speedometer using special LED’s (Figure 9).



Figure 9. ACC displays in the increments of the speedometer

The selected desired speed is marked by a green LED in the speedometer. Slower lead vehicles detected by the ACC system are shown signalled by red LEDs that will display the difference in velocity between both cars. The speed is then reduced by the ACC system in order for the selected distance to be held and maintained.

The measuring and recording equipment

The central PC from which the ACC algorithms were generated also served to log and regulate the data. It was linked to the video mixer and the video recorder stored in the boot of the car. The keypad and the monitor were removed from the vehicle for the purpose of the study. See Figure 10 for the structure of measuring and recording equipment.

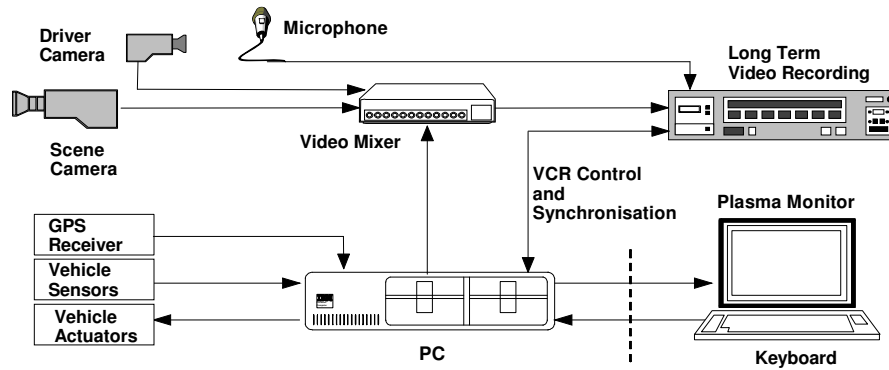

Figure 10. Structure of the overall hardware set-up in car

Recording of the data

Data from the radar sensors were recorded onto a removable hard drive. Additionally to the data recorded from the navigation system, a GPS receiver was installed from which the data stream was synchronised and continuously recorded along with the other data. Turning the ignition on automatically begins the recording process. After each start, a new data file is opened. The file name included the driver code and the respective drive number (e.g. GM36). Switching off the ignition would automatically close and save the data file. Table 6 shows an overview of the total driven kilometres per participant and the number of drives effectuated per driver. The number of drives corresponds to the number of data files analysed per driver. The variables were measured at a 10Hz frequency. See table 5 for the list of variables measured.

Table 4. List of variables measured in the long-term study

Automatically recorded variables	Manually recorded variables
Time [s]	Traffic quality [1-4]
Steering wheel angle [rad]	Type of road [1-4]
Acceleration [m/s ²]	Time of day [1-4]
Target acceleration [m/s ²]	Weather condition [1-2]
Speed [km/h]	Visibility [1-3]
Speed of lead vehicle [km/h]	
Set desired speed [km/h]	
Distance to lead vehicle [m]	
Target distance [m]	
Travelled distance [km]	
Time headway [s]	
Brake force applied by ACC [0..1]	

Brake force [0..1]
Time code [-]
Set desired distance [s]
Indicator usage [-]

The situation parameters that were manually recorded, were added manually at the IVI Fraunhofer in Dresden, through video analysis. For the analysis of the data, the binary data were converted into ASCII data and then, imported into statistical programs for the purpose of the analysis.

Video recording

For the video recording a special long-run recorder (Panasonic AG-6370) was used which enables recording at a reduced frame rate. Thus, on a four-hour normal videocassette with a 25 frame per second format, it enabled, with a recording rate of four frames per second, approximately thirty hours of recording time. The video recorder produces a time-code which it delivers to the PC. The time-code is saved alongside the other data enabling a perfect synchronisation of the data and the video stream.

The scenery as well as the driver camera were simultaneously recorded and super-imposed onto a single screen with the use of a video-mixer (Figure 11). The scenery camera was tucked behind the rear-view mirror and was relatively inconspicuous. The driver camera was a mini camera that was fixed to the dashboard (Figure 12).



Figure 11. Example of the recorded video scenery

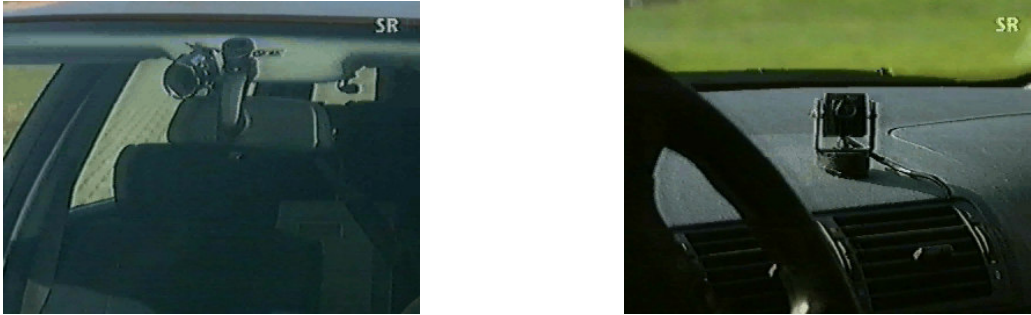

Figure 12. Scenery and driver cameras

Interview recording

The interviews were recorded using a microphone (Shure SM57) and a digital dictaphone (Sony ICD B16). The content of the recorded tapes were then transcribed onto paper after the interviews.

5.1.2.5 Procedure

Participants carried out the experiment individually. Throughout the entirety of the test period, participants were videotaped. Instructions were given to participants individually, when the vehicle was handed over to them. They did not need to be briefed on the usage of the system as they had learned how to operate it on the test track. Participants were briefed on the aim of the study and asked to use the test vehicle as their own vehicle and the ACC-system as though it had been implemented into their own car. The apparatus in the vehicle was explained to participants and they were taught how to switch the PC on and off in case of a malfunction as well as how to change the video in the video-recorder. The procedure was reiterated and any remaining questions were answered. Participants were given the keys once it was clear that they had understood what they had to do and had no further questions. An ‘emergency’ telephone number was given to them in case they had a problem with the equipment or the vehicle.

At the end of the trial period, participants filled out a fairly general questionnaire related to perceived understanding, feelings of safety, trust and satisfaction with the system. When the participants had no further questions, they were debriefed orally and also given a sheet regarding the nondisclosure of information. Semi-structured interviews were conducted after the analysis had been completed with hindsight of drivers’ usage of the system over time, eventual operational strategies and responses to semi-critical situations. The interviews were performed to delve further into certain aspects partly covered by the questionnaires. They focused in particular in assessing drivers’ familiarisation processes to the ACC system as well as confronting drivers about their particular system usage in order to understand and evaluate the reasoning and processes behind their behaviour. Further questions dealt with perceived learning hurdles and drivers’ informational needs. Drivers were specifically asked to describe

how they would improve the system's interface and what form of online feedback or help they would most benefit from, to effectively and safely learn the ACC system's functionality, operation and limits. Participants received letters at home inviting them for an informal lunch in their hometown. The interviewer and the commissioned attended the interview. At the outset, participants were asked to read a short description of the ACC-system's operation and limitations (see Appendix A). Participants were then briefed of the aim of the interview. The interview began once it was clear that the participant understood the aim and had no further questions. At the end of the interview, participants were debriefed orally. The interviews were recorded and the content of the recorded tapes were then transcribed onto paper by both the interviewer and independently by a second person.

5.1.3 Results

Before the detailed analysis results are presented, an overview of the main statistical parameters of the study are given. As shown in table 6, participants mostly drove on the motorway (between 55% and 87% of the total driven distance). All participants used the ACC system most often on the motorway (67% - 94%), occasionally on secondary roads (4% - 15%) and only very little use of it was made on city roads (1% - 4%).

Table 5. *Statistical overview of the main study parameters*

Driver Nr.	2	3	4	5	6
Experiment time (days)	18	15	17	14	15
Total driven distance (km)	1923	3910	3080	1918	3181
-rel. proportion of city drive	29,6%	9,2%	10,1%	15,5%	8,1%
-rel. proportion B-type roads	10,2%	13,7%	11,3%	29,5%	4,9%
-rel. proportion motorway	60,2%	77,1%	78,6%	55%	87,1%
Total driven km with ACC	1128	1754	2683	619	2466
-rel. proportion of city drive	1,1%	3,9%	2,5%	1,5%	1,7%
-rel. proportion B-type roads	4,9%	11,9%	10,2%	15%	3,9%
-rel. proportion motorway	94,1%	84,3%	86,9%	67,4%	94,4%
Number of drives	96	68	64	79	94
-city drives	84	54	49	71	79
-B-type roads	26	35	23	40	22
-motorway drives	30	37	26	17	35
Mean driving distance (km)	20	57,5	48,1	24,3	36,2
-city drives	6,8	6,7	6,5	4,2	3,3
-B-type roads	7,6	15,3	15,1	14,2	7,1
-motorway drives	38,6	79,5	92,9	61,5	78,9

5.1.3.1 Usage of system functionality

Overall use of the system

In order to achieve control over the independent variables and eliminate any confounding variables, the analyses of the system's overall usage and operation was measured on the motorway with low to medium traffic, during daytime and with no adverse weather conditions (low visibility or rain). In other words, all external measurable data were held constant. For the automatic deactivation of the system at a speed below 30km/h, the data from B-type roads and motorway exits were included. As the frequency of operation and occurrence of system limits for each driver is highly dependent on the number of kilometres driven with the ACC system—three drivers drove more than 3000 kilometres while two drivers drove just under 2000 kilometres over the two and a half week free-drive period (see table 6)—the related samples analysis of variance tests were conducted for the relative differences in usage and operation between drivers.

In the first instance, an analysis of the overall use of the system was conducted to gain clarity in the number of times the system was used over a longer period of time and whether any

learning effects were visible. For a comprehensive analysis over the total time period, the total driven kilometres for each driver were divided into quarters. Thus a more detailed interpretation of any eventual changes in the process would be discernable compared to three stages. Figure 13 shows the total amount of times the ACC system was used over the test-period for each driver. The absolute frequency of usage is coupled with the total number of kilometres driven. Driver 3, for example, used the system considerably more often than driver 5 but also drove considerably more kilometres. Figure 13 enables a qualitative comparison within drivers. The comparison here, between the participants' absolute frequency of system usage is of less interest compared to the differences in system usage over time for each participant, as shown in the differences between quarters. A quantitative comparison in the usage of the system between drivers is shown in Figure 14 where the frequency of usage was compared per kilometre driven.

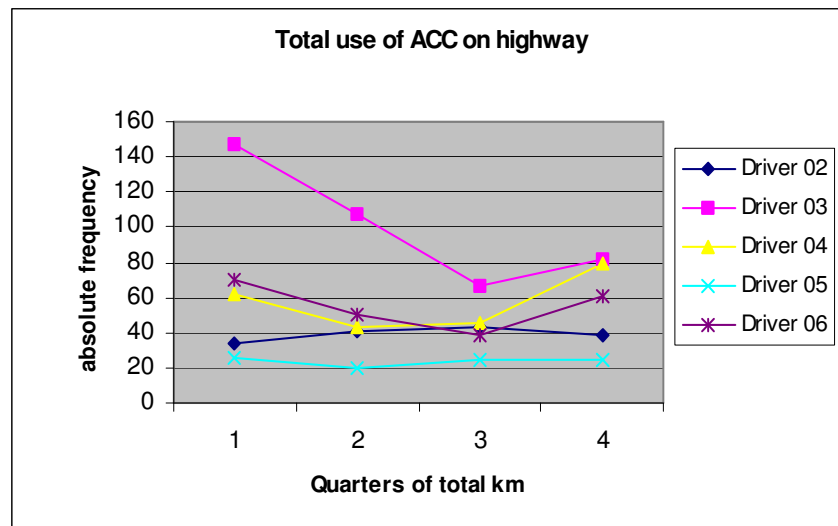

Figure 13. Total absolute times the ACC was switched on, on the highway

Figure 14 shows the average amount of times the ACC was switched on per kilometre (or frequency per km driven). Overall, the graph shows a similar pattern within, however, changes in the process over time between drivers are more discernable.

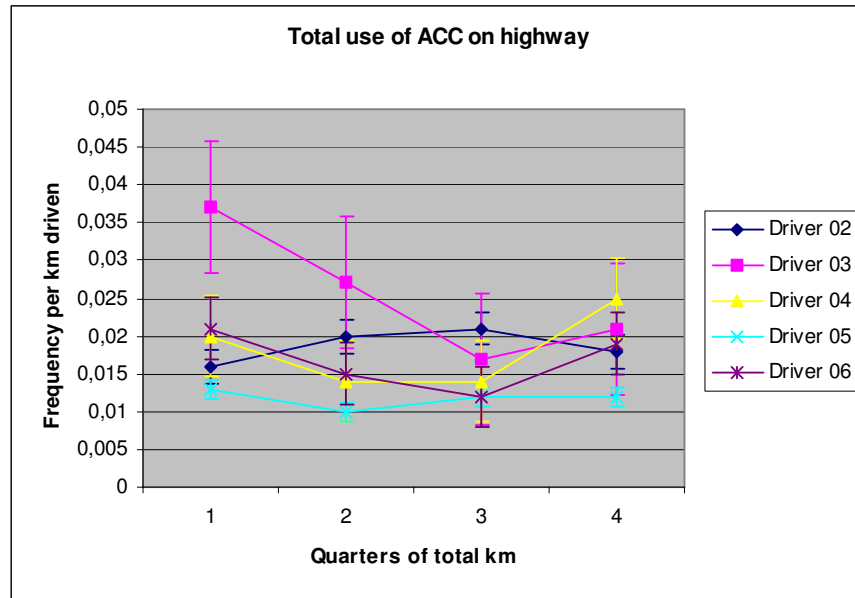

Figure 14. Average amount of times the ACC was switched on per kilometre

Two levels of interpretation are possible from the graph. Firstly, two different types of usage strategies can be observed: a cautious approach with a steady increase in usage over time (driver 02) and a very early sustained usage of the system, with a gradual fall over time (drivers 03, 05, 06). The gradual fall over time can be attributed to more than one reason, as the participants' answers made clear in the interviews. Firstly, it may be attributable to the novelty of the system wearing off. Driver 3, for example, states:

"I only tested the system intensively at the beginning, the first 4-5 days. In the first third, I really tested the system, in the second third, I partly forgot that the system was there and in the final third I remembered that I was supposed to use the system!"

Another reason that was mentioned in the interviews, was that as the test-period time elapsed, participants took less time to make use of the system. A further reason for a decline in ACC usage might be attributable to a period of frustration with the system. Drivers reported being surprised by the system as its reactions did not correspond to the awaited system reactions. This was the case, for example, when the ACC accelerated in a motorway exit, before a curve, or did not decelerate behind a motorcycle. Following these situations, a natural consequence would be a reduced system usage.

The different usage curves are also attributable to participants' individual characteristics and learning strategies. As the results from the interviews show, a more frequent use per kilometre, especially in the first quarter, could be attributed to more technical affinity. Driver 3, for example, states:

"I am always very interested in new features in vehicles and like to test them out. I first test the possibilities of the system and its limits. Then I find the usage of the system that is best"

suited to me. I usually go about it with trial and error to establish the different usage possibilities.”

Driver 6 explains that she is not so interested in technology but she is keen on trying new features and would not be in the slightest way shy or worried to use them. She states:

“I am interested in technical things but I want to know how it works and not why it works in a certain way. I would not read a whole manual to find out how something works but would only read the parts that I find interesting. If something is still unclear, I would find it in the index and try it out.”

In contrast, driver 2 sees herself as having an average interest in technical features and uses them with caution. She states:

“I am generally very cautious in using new technology, especially in the car. I would prefer to have everything explained to me before attempting to use the system on my own.”

The second level of interpretation of the graphs relates to the suggestion of the existence of different stages in system usage over time. These stages are analysed more closely in the quantitative analysis of drivers interactions with the system in terms of drivers basic system operations (in specific situations as well as in the system’s different modes), the usage depth of the system’s possibilities i.e. different following distance settings, the frequency of operational errors, drivers time-to-intervention in semi-critical situations and drivers braking forces in semi-critical situations.

5.1.3.2 Operation of the system

Activating the system

Activation is effectuated by using the +/- button or the resume button (which selects the previous set desired speed). The interpretable difference in driver strategy of these two activation possibilities correspond to a rather conservative setting of the previous desired speed versus a more progressive, situation-adapted re-activation of the system with a newly selected desired speed. In Figure 15 activation of the system is demonstrated for all five drivers.

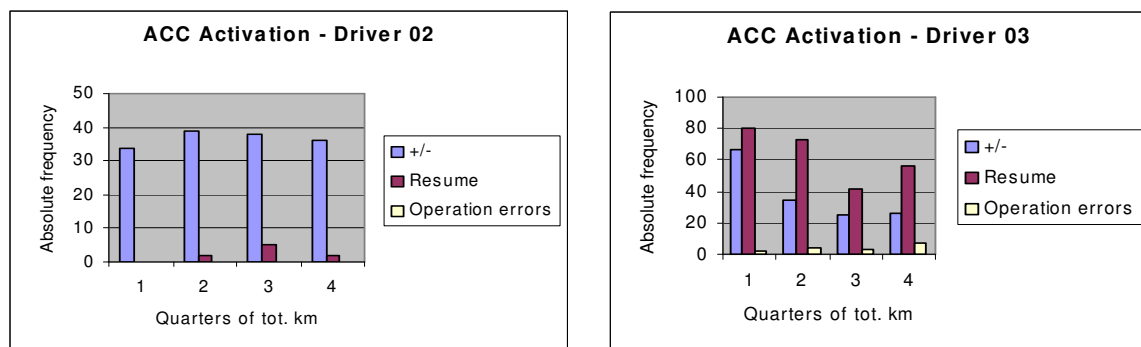

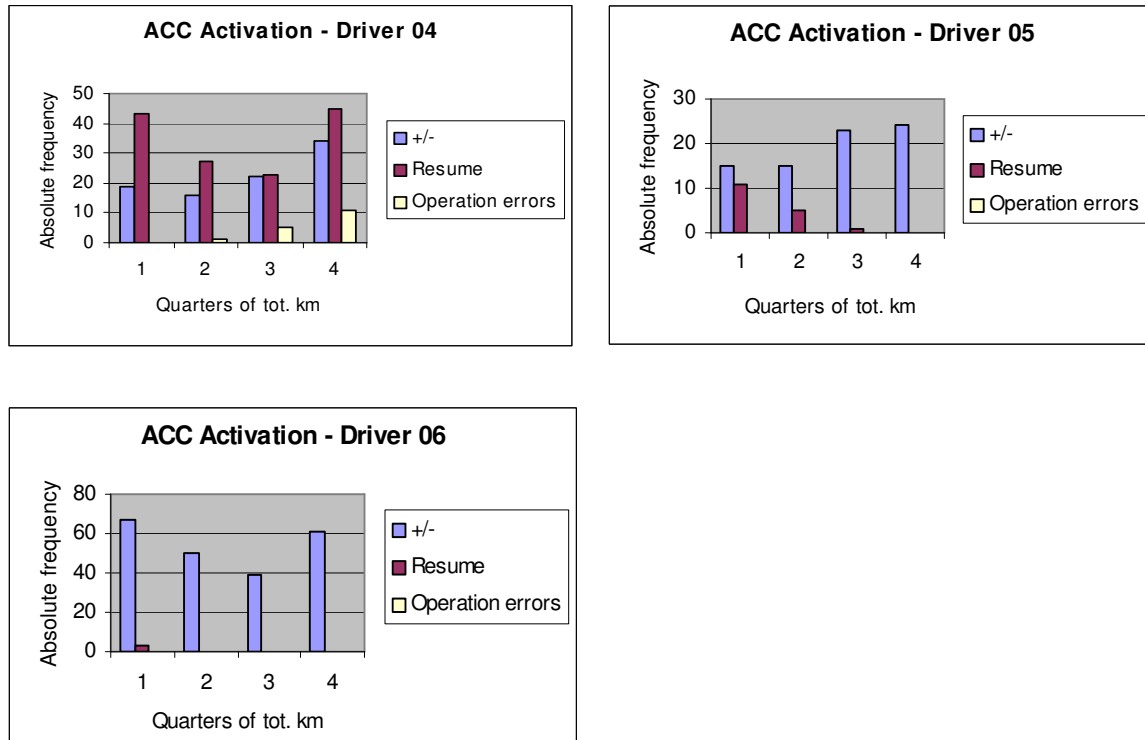

Figure 15. System activation for all drivers

Beyond the differences the graphs show in the absolute frequency of system activation between drivers, the graphs demonstrate the differences between drivers in their selection of preferred activation method and also the changes in their adopted strategy over time. Single-factor analysis of variance for related samples showed significant differences in the relative usage of the ‘+/-’ button, $F(4,15) = 6,12$, $p = .04$ and in the relative usage of the ‘resume’ button, $F(4,15) = 33,11$, $p = .01$ between drivers. The highly significant differences in drivers’ activation rates reflect the different strategies between drivers. Drivers 2 and 6, for example, only use the +/- button, whilst drivers 3 and 4 tend to use the resume button predominantly. Further, strategies for activating the system changed over time within drivers. Driver 5, for example, continuously increased his use of the +/- button, whilst driver 3 continually decreased his usage of the button. These differences may be due to drivers not knowing or forgetting the possibilities for system activation but is more likely to reflect a combination of individual driving style i.e. more active, setting the desired speed new accordingly to the situation or more passive, selecting the last set-desired speed, as well as the success of the integration of the system into their own driving style.

Changes in the use of the ‘+/-’ button or the ‘resume’ button within drivers over all four quarters of total kilometres driven, were not significant, $F(3,16) = 0,44$, $p = .72$ and $F(3,16) = 0,18$, $p = .90$. This suggests that no considerable changes in drivers’ strategies occurred from one quarter to the next. The number of operational errors was negligible for all drivers.

To conclude, major differences were found in the activation strategies between drivers that are largely attributable to the reasons outlined above, in the analysis of the overall use of the system. A quantitative analysis of the differences between drivers in the learning process over time, however, did not lead to any significant results. Although changes in strategies over time are noticeable within drivers, the small number of participants does not give a statistically representative account of these changes. More insightful results were to be gained by considering each driver separately and qualitatively analysing the changes in the learning process through the interview and questionnaire responses.

De-activating the system

The de-activation of the system, unlike the system activation, already has implications for the second stage in Anderson's model, the 'knowledge compilation stage'. This stems from the different means in which the de-activation of the system can be effectuated. The driver can de-activate the system by selecting the 'I/O' button or by applying the brakes. If no action is taken and the vehicle reaches a speed below 30km/h, the system switches itself off automatically. Figure 16 shows the de-activation methods for all drivers. The graphs represent the absolute frequency of system de-activation split into quarters of the total driven kilometres. The de-activation methods are separated for each quarter into the various de-activation processes (manual and automatic). De-activation of the system by braking was further divided into moderate braking (a braking force below $-2,6\text{m/s}^2$) and hard or 'panic' braking (braking force greater than $-2,6\text{m/s}^2$). The significance of the braking force in terms of driver's comprehension and understanding of the system was further analysed from the video to determine the particular situation that provoked the 'panic braking', this analysis will be returned to later in the classification analysis of these situations.

Soft braking is the most frequent way in which the system was de-activated for all drivers except for drivers 5 and 6. These drivers, especially towards the end of the test-period preferred to de-activate the system manually, using the I/O button. Over time an inverse trend was observable for driver 5, as manual de-activation increases proportionally to the decrease in the frequency of moderate braking. This propensity towards this de-activation method is further observable in driver 2. The rate of automatic system de-activation was relatively low for all drivers except driver 4 and were not further analysed.

The implications of the system's de-activation in terms of Anderson's model go beyond the first stage and into the second stage. On the one hand, an understanding for one of the system's limits can be demonstrated by braking or switching the system off manually before the system switches itself off under 30km/h. On the other hand, a higher rate of de-activating the system manually with the I/O (on/off) button demonstrates the ability to predict future system states and may also indicate an integration of the system into the normal driving style.

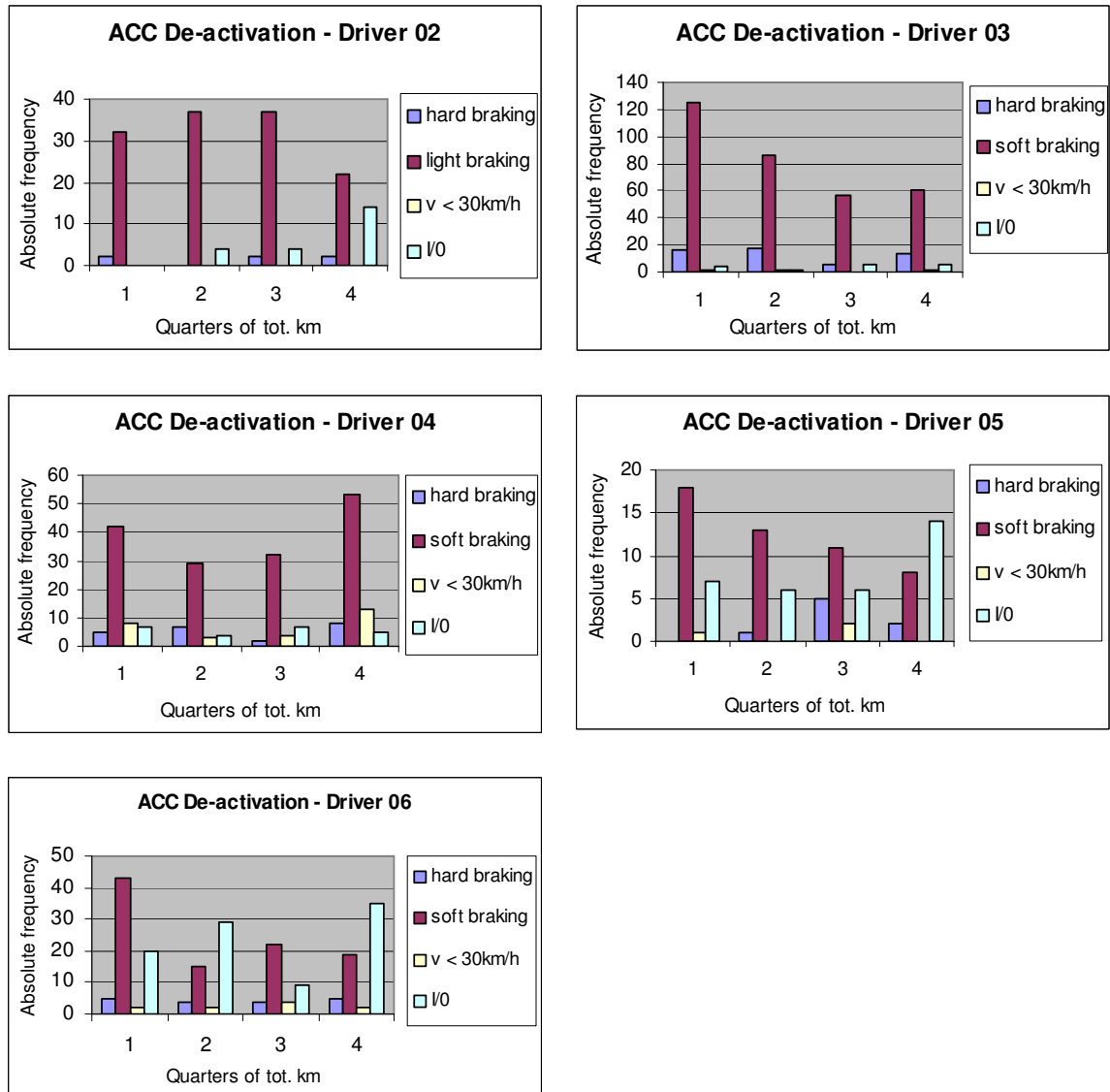

Figure 16. System de-activation for all drivers

A comparison between the de-activation method used by driver 2, 5 and 6 over the four quarters of total driven kilometres demonstrates a trend towards a greater use of the I/O button over time and a corresponding reduction in the rate of de-activation through the use of the brake pedal. This tendency shows support for a learning progression: from testing the basic functions of the system (most often using the brakes to de-activate the system) and experiencing system limits (de-activation with speed below 30km/h) a situation specific model is built enabling a more accurate prediction of future system states and the ability to predict the need for an active intervention in order to regain manual control. For driver 3 and 4, in contrast, no progression in their operational behaviour towards making better predictions of the need to intervene can be seen.

The graphs below show the inverse correlation between the use of the I/O button and the use of a moderate braking force to de-activate the system. Figure 17 shows the use of the I/O button to de-activate the system as a percentage of the different de-activation possibilities, whilst Figure 18 shows the absolute number of times the system was de-activated per times the system was used, for all drivers in quarters of the total driven kilometres. Frequency per use of ACC was calculated to enable the comparison between drivers. However, in order to gain a qualitative feel for the frequency of this situation a table is provided where the absolute numbers are provided (see Table 6).

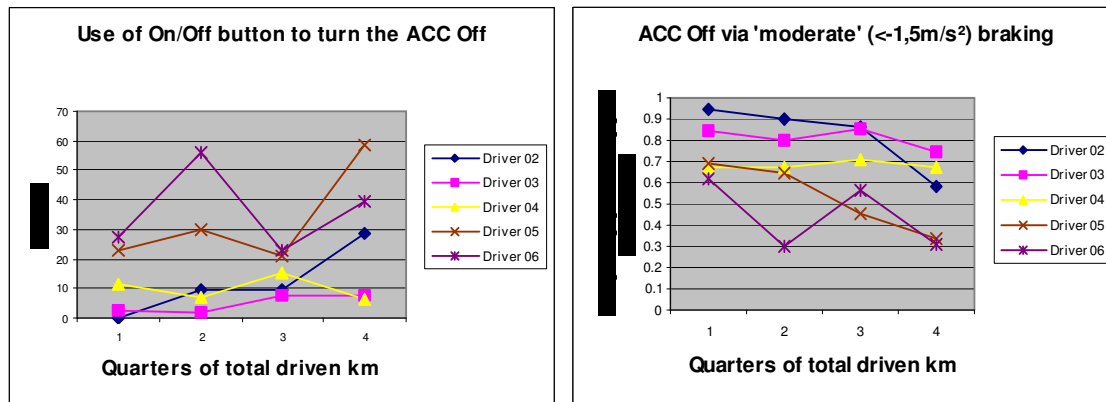

Figure 17. Use of I/O to de-activate the system Figure 18. De-activating the system with a moderate braking force (<math>< -1,5\text{m/s}^2</math>)

Table 6. Absolute frequency table of decelerations smaller than $-1,5\text{m/s}^2$

Driver No.	Quarter 1	Quarter 2	Quarter 3	Quarter 4
2	6	14	9	6
3	54	49	15	20
4	18	20	12	25
5	4	5	8	4
6	15	10	3	1

5.1.3.3 Occurrences and reactions to system limits

Over time and especially in the testing phase, drivers build up a model of the way in which the system works i.e. effectuates accelerations and decelerations in different situations, and gain experience in setting secondary / optional functions according to the appropriate situation i.e. choosing the selected distance on a country road. The experience gained will then lead to further testing of the advanced settings, possibly in connection with system limits that the

driver has already experienced (conscious experimenting) or that have not yet been experienced.

At a higher interaction level, ‘taking-over situations’—situations in which the driver must take over the control from the ADAS—were evaluated. These situations broadly cover the system limits over the regulation task. They are broadly dividable into two categories of situations (Weinberger, 2000), see Table 7. Types of system limits (sometimes) requiring driver intervention Category A includes the type of situations which the system is not designed to cope with in which driver intervention is always necessary i.e. stopping at traffic lights, the approach to standing vehicles, decelerating behind another vehicle to a speed below 30km/h, in steep curves and in the event of man objects (bridges, rail-tracks etc.). The situations in category B include the type of situations in which driver intervention is sometimes necessary i.e. close cut-in of another vehicle or of the ACC vehicle, the deceleration of the lead vehicle, the approach to another moving vehicle and the case of uncertain object detection (cyclists, motorbikes etc.). The categories differ in terms of criticality and learning intensiveness. They represent, on the one hand, situations where drivers must learn the rule once i.e. that intervention is always necessary, and on the other hand, situations requiring production rules from drivers’ active evaluation and decision making processes. Of particular interest, therefore, is the latter category, clearly representing the most learn-intensive of the two requiring more experimenting and ‘learning with experience’.

Table 7. *Types of system limits (sometimes) requiring driver intervention*

Category A - The type of situations which the system is not designed to cope with in which driver intervention is always necessary	Category B - The type of situations which require more „learning with experience“ in which driver intervention is sometimes necessary
Stop at traffic lights	Deceleration of the lead vehicle
Deceleration behind other vehicle to a speed below 30 km/h	Cut-in of another vehicle
Approach to a standing vehicle	Cut-in of the ACC vehicle
Steep curves	Approaching another moving vehicle
Man objects, e.g. bridges, rail tracks...	Uncertain object detection e.g. cyclistskes...

In order to determine the extent of the problem, the number of interventions through hard or ‘panic’ braking were filtered out from the data. The first criterion for these situations was a braking force higher than $-2,8\text{m/s}^2$. This rate of deceleration is far in excess of the ACC system’s programmed deceleration capability and is above the rate of drivers’ subjective comfortable braking deceleration. The second criterion for inclusion, was that driver intervention occurred after the beginning of the traffic situation that caused the need for

deceleration. Each situation was analysed through the use of video analysis to determine the exact conditions and the type of take-over situation it represented. Speculations of the reasons for the intervention are reported in the subjective evaluations in section 5.1.3.5.

Figure 19 shows the total number of instances, partitioned according to the type of take-over situation, in which hard or 'panic' braking was recorded over the entire test period for all participants. Overall, 196 instances were recorded. The types of take-over situations, as shown in figure 23, show that 76% were category B situations, requiring active driver interpretation, and 24% were category A situations, which always require driver intervention.

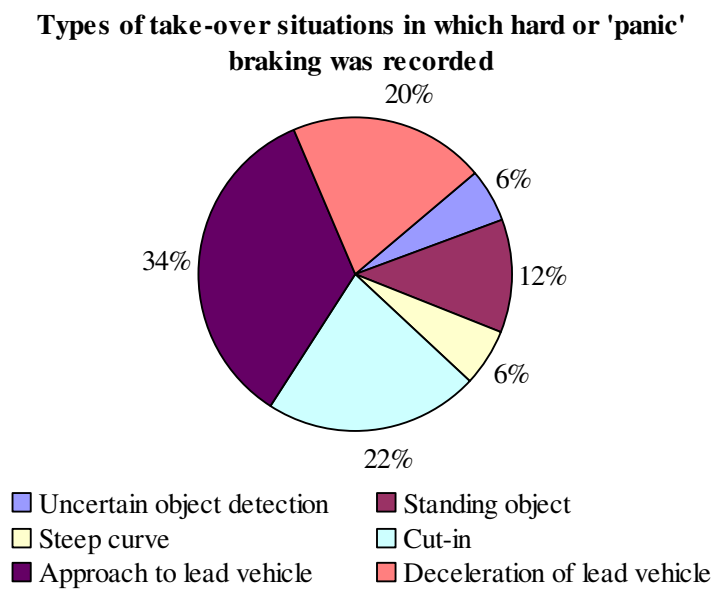

Figure 19. Categories of take-over situations in which hard or panic braking was executed

The learn-intensive situations especially, often represent a transition from free driving to a car following condition. In this case, conditions where the braking required exceeded the maximum braking capacity ($-1,6\text{m/s}^2$) of the ACC system. In such situations, intervention of the driver or 'taking over control of the system' can be done in two ways: direct intervention with the pedals (braking or accelerating) or by turning the system off with the I/O button. Situations where the limits of the system are reached often demand a driver response in what is often within a very limited timeframe. Thus, if the system limit was not predicted in time before it's occurrence, it is very likely that the driver will apply the brakes in order to avoid deviating from the middle of the road or possibly even to avoid a collision.

To determine whether drivers' hard braking reactions were justified in terms of the traffic situation or whether the reactions were panic braking events due a lack of ability to predict the

need for intervention, an analysis of the drivers interventions times was conducted. For this analysis, take-over situations were categorised in terms of the learning to be effectuated. Time to intervention (TTI) was then determined on the time the driver took before intervening from the moment a vehicle had come into the ACC system radars' field. It was hypothesised that the number of situations in which drivers intervention times are longer, will increase over time as drivers learn the system limits and gain trust in the system. Figure 20 and Figure 21 show the frequency of 'hard braking' events per usage of the ACC for each driver in each quarter of the total driven kilometres.

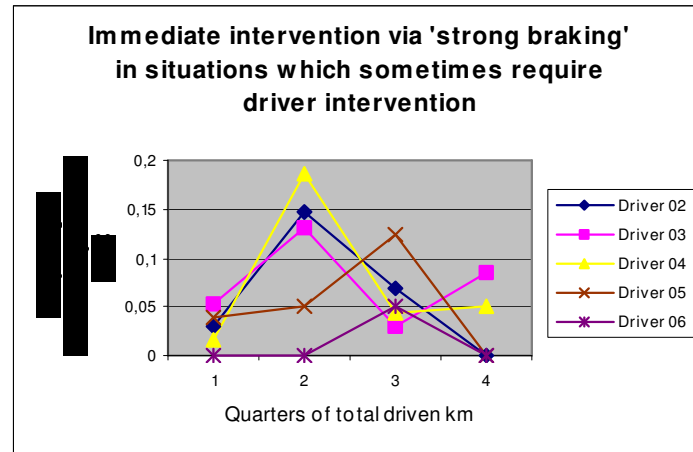

Figure 20. Panic braking analysis of immediate interventions in take-over situations

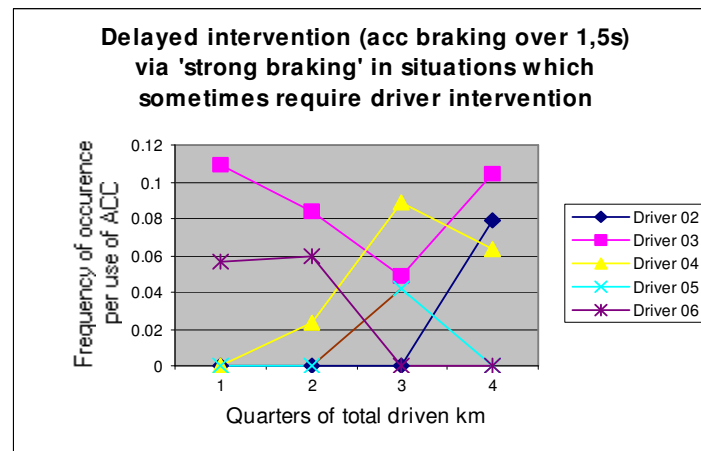

Figure 21. Panic braking analysis of delayed interventions in take-over situations

Figure 20 shows that in situations requiring drivers to intervene only sometimes (category B) there was a trend towards 'testing the limits of the system' at the beginning in what are usually benign situations, followed by a certain apprehension of the system capabilities after experiencing more critical take-over situations in the second (drivers 02, 03, 04) or third quarters (drivers 05, 06) and ending, in the last quarter, in a more balanced, personalised 'steady usage' of the system. By the end of the fourth quarter, three out of five drivers

(drivers 2, 5 & 6) have reduced immediate intervention to a rate of zero. Driver 4, for example, reached the highest rate of immediate intervention, per system usage, in the second quarter. Every 1 in 5 times the ACC system was used, an emergency brake intervention occurred. This rate was then reduced in the third quarter to 1 in 20 and stabilised at this level in the final quarter.

As opposed to immediate braking, where little can be learnt about the braking capacity limits of the ACC system, letting the ACC take over the deceleration (at least until an intervention is absolutely necessary) will tell a lot more about the system braking limits. Particularly in the learning period, or when the prediction of the need to intervene was faulty, the driver's braking intervention will be delayed, critical and thus hard. For this type of 'panic' braking, drivers delayed interventions were included when the ACC system had been braking for at least 1,5 s before the driver's intervention. Figure 21 shows a tendency for an increased delayed intervention in the fourth quarter, as shown by three out of five drivers (drivers 2, 3 & 4). Drivers, 5 and 6, however, are, by the end of the fourth quarter at a rate of zero delayed interventions showing the achievement of Anderson's third stage of proceduralisation. These two drivers (2 and 6) have gained enough trust and knowledge of the system limits not to immediately intervene with a 'panic' braking force and have learnt to predict the different ACC system limits as well as the appropriate braking force needed specific to each situation.

The significances in the drivers' rate of immediate and delayed interventions were tested between quarters of the overall drives and between the drivers using a single-factor analysis of variance test. For drivers rates of immediate and delayed intervention, no significant difference was found between the quarters of the overall time driven within or between drivers. Thus, the results did not show any support for the hypothesis that delayed interventions will increase over time. A tendency, however, for driver's rate of immediate intervention to decrease over time is distinguishable in Figure 20. This trend was presumed to be due to the participants' increased trust in the system and learning of the system limits over time. The interpretation of the trend was confirmed by the participants in questionnaire responses after the driving period (see section 5.1.3.5).

In summary, the analysis of drivers late, or delayed braking showed regularities between drivers but presented no overall trend over time. The analysis of drivers immediate braking showed a clear trend towards a reduction of these events over time. Considered both together, the graphs show a progression in the usage and operation of the ACC system for all drivers. However, the relative comparisons in operation and usage reveal considerable inter-driver differences. On the basis of this analysis and with support of the subjective data, it may be argued that two out of five drivers (driver 5 & 6) reached Anderson's proceduralisation level after two and a half weeks of intensive ACC driving.

Despite filtering out the influence of external factors, (i.e. traffic quality, road type, weather condition etc.) the considerable differences in the length and distribution of the drives (see table 6), individual differences in driving style or the reason for using the car (holiday, urgent or work-related car trip) could not be kept constant. This largely accounts for the specificity of individual differences in operation and usage of the ACC at particular times in the learning process.

5.1.3.4 Range of application

Distance setting according to environmental conditions

At the first level of Anderson's framework, drivers will learn to make use of optional functionalities such as the setting of the desired time headway (1,0 s, 1,3 s, 1,6 s or 1,9 s). The performance of this operation is based on drivers' explicit knowledge. The operational steps are learnt and can be easily explained to a third person. However, setting the appropriate distance in adverse conditions, various traffic densities and on different road types is gained through experience and will largely be influenced by personal driving style as well drivers' motivation. In a first step, the setting of the selected headway was analysed in order to test the hypothesis that drivers learn to adjust time headway (TH) according to visibility, time of day or adverse weather conditions. In a second step, the integration of TH into the drivers driving styles was analysed. It was hypothesised that through the adaptation of a preferred TH from the available range, very sporty or very cautious drivers would select opposite extremes of TH settings.

The graph below shows the total amount of times the selected distance was changed for each driver over the course of time (separated into quarters of the total kilometres driven). A single-factor analysis of variance for related samples between the relative changes between drivers and quarters revealed no significant differences. This graph allows a qualitative analysis of statistical differences between drivers over a two and a half week driving period. With the exception of the first quarter for drivers 3 and 4 who made a proportionally higher number of headway changes, drivers showed a similar usage frequency of the setting over time. Drivers tended not to make many changes to the selected distance, although a slight increase in frequency is observable in the last quarter for almost all drivers.

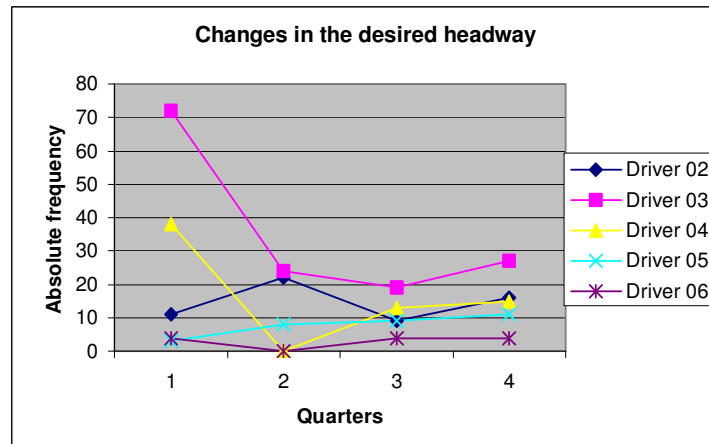

Figure 22. Absolute number of changes in desired headway

The adjustment of TH to the type of road and traffic conditions over time was further analysed as these parameters averred to be the main variables dependent on changes in TH. The selected distance (1,0 s, 1,3 s, 1,6 s and 1,9 s) was plotted against the changes in the traffic quality as well as the changes in the types of road within each quarter of the total driven distance for all drivers. The coding used in the video analysis for the types of road and for its different levels, are summarised in Table 8.

Table 8. Coding used for the different levels of road types

Codes for the different levels of road types	Type of road
10	for town road (no further distinction)
11	for town road with one lane
12	for town road with two lanes
20	for country road (no further distinction)
21	for country road with one lane
22	for country road with two lanes
30	for motorway (no further distinction)
31	for motorway with one lane
32	for motorway with two lanes
33	for motorway with three lanes

Before the dependency of changes in TH to the traffic quality and type of road parameters are discussed, the term “traffic quality” is defined. The term “traffic quality” is used in traffic engineering to assess the prevalent traffic state on road stretches. Traffic quality can be understood as being a quality assessment summary of the traffic flow (Breitenberger, 1998).

The assessment is based on certain characteristics which describe the quality of the traffic flow. These characteristics include, speed, time of journey, possibilities to overtake, waiting times, traffic jam length, number of full stops, number and intensity of braking manoeuvres, and level of emissions.

The traffic quality criteria results from a macroscopic ascertainment of the traffic concentration i.e. the number of vehicles per measure of time, denseness i.e. on the ratio of vehicles on the length of the road stretch, and on the mean speed of the traffic flow. These three parameters are considered to form the base of traffic activity. The traffic quality was generated through the INCOGNITO program (Breitenberger, 1998), which attributes the different traffic quality states with values between 1 (lowest traffic quality) and 6 (highest traffic quality) and, as mentioned earlier, implements these directly in the driving data.

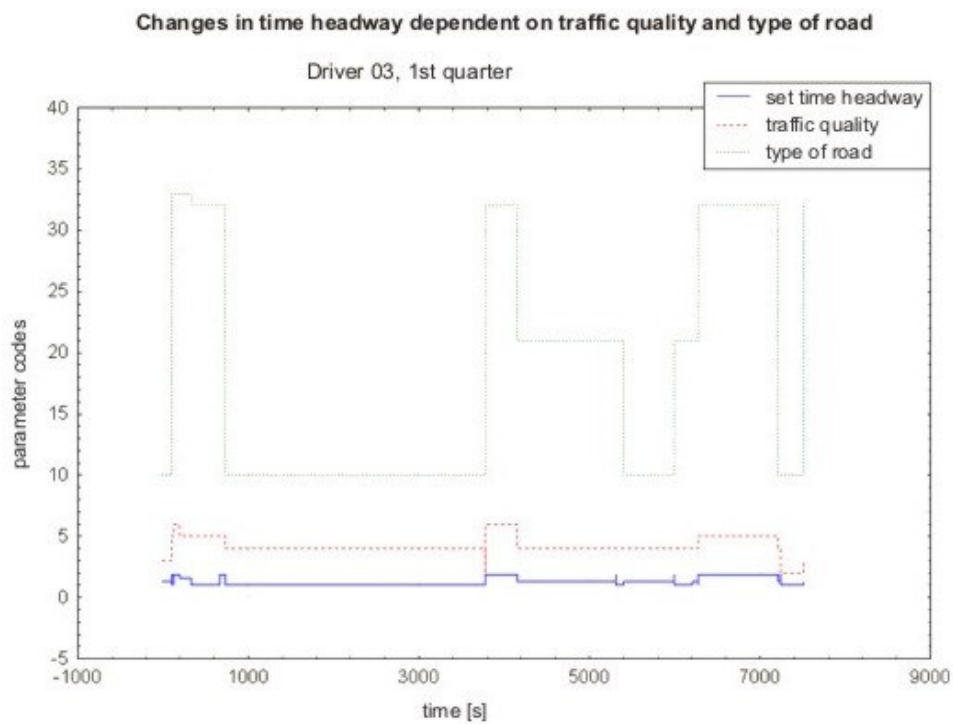

Figure 23. Setting of the selected distance dependent on the traffic quality and the type of road for the first quarter of total driven kilometres for driver 3

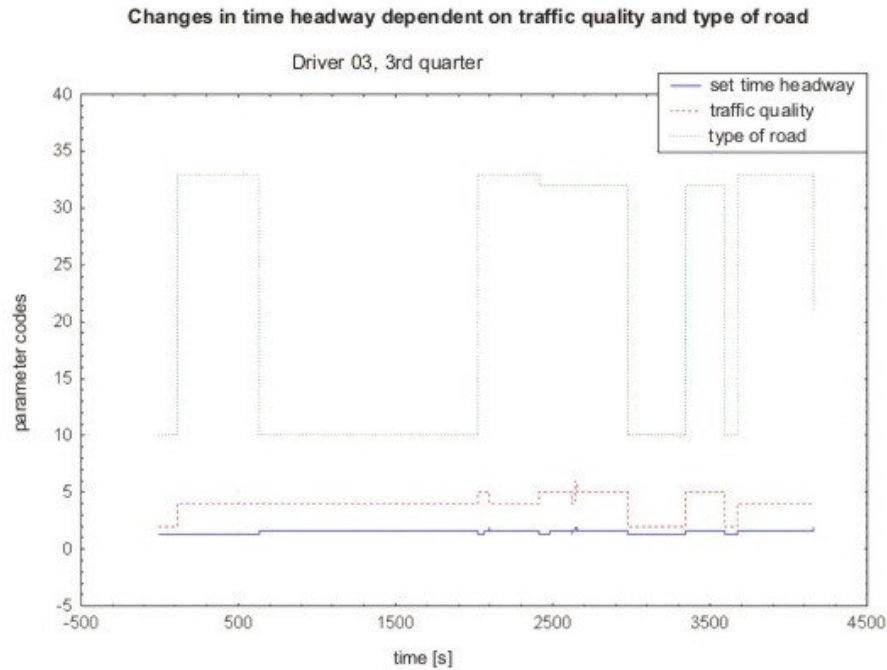

Figure 24. Setting of the selected distance dependent on the traffic quality and the type of road for the third quarter of total driven kilometres for driver 3

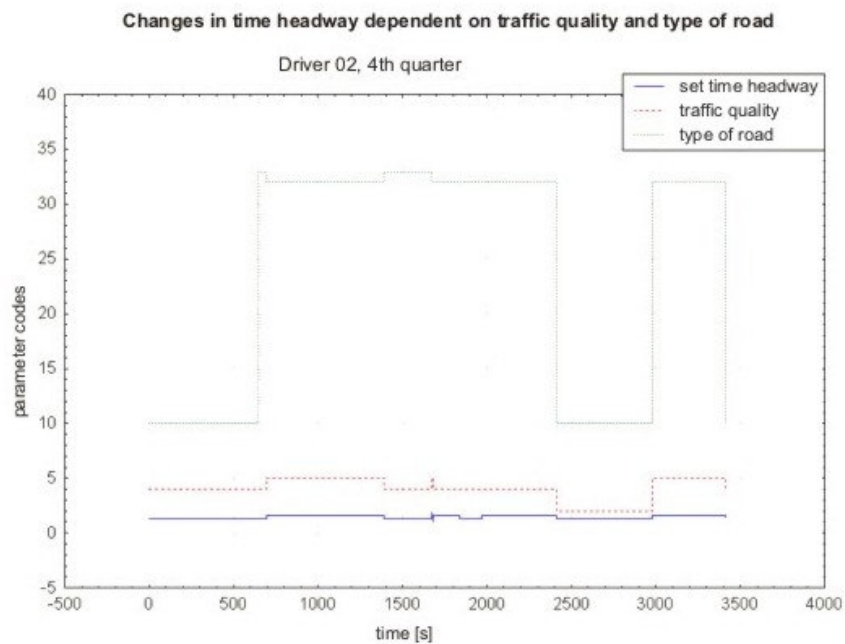

Figure 25. Setting of the selected distance dependent on the traffic quality and the type of road for the fourth quarter of total driven kilometres for driver 4

Figure 23, 24 and 25 show that a change in the selected distance is mostly accompanied by a change in either the traffic quality or the type of road. Deviations from the dependency between changes in TH and changes in traffic quality and / or type of road were extremely rare. This correlation can be explained by the simple fact that at lower speeds, a smaller

headway is preferable to prevent other cars cutting in. It can also be expected, based upon the traffic quality definition, that a change in the latter would bring about a change in the set headway. In dense traffic, and consequently low speeds, a large time headway is inappropriate. The set TH was, therefore, often adapted to the type of road and/or to the traffic quality. However, the set TH was not changed as often as the external parameters changed. As the results from the interviews showed, the difference between 1,3 s and 1,0 s as well as the difference between 1,3 s and 1,6 s was so large, that participants even tried to avoid these settings towards the end of the study. When these extreme TH were used (at the beginning of the study), they were immediately changed in accordance to both external parameters. When the middle TH values were used (1,3 s and 1,6 s), a change in the type of road and/ or in the traffic quality, did not automatically lead to a change in the TH. Noteworthy, however, was that a change in the TH was always marked by a change in the type of road and/ or in traffic quality.

Figures 27 to 29 were selected to exemplify the results found for all drivers, as drivers 3 and 4 made the most TH changes of all drivers and because no other dependent variables (apart from type of road and traffic quality) were found for any drivers. The graphs give the impression that all parameters change at the same time. This is, however, not the case but is due to the filtering of the data. The parameters were filtered out only at the time of a change in TH. If the traffic quality changed, for example, but no changes to TH was made, the change in traffic quality would not be visible in the graph. This analysis enables a clearer depiction of the dependency between parameters. In order to further the graphs conciseness, the drive endings were deliberately left out if the selected distance was not changed for the rest of the drive duration. Upon closer inspection of the data, the simultaneity in TH and road type or traffic quality change, observable in the graphs, actually happens within a 5 and 10 minute delay. This time gap can easily be explained. If the type of road (secondary road or motorway) changes, the driver will not immediately respond by changing the TH. The change in TH will only take place after situations arise in which he or she deems that a shorter or longer TH would be more favourable. Thus, it is not striking that a change in road type or traffic quality did not necessarily lead to a change in TH, however, following a change in TH, a change in road type or traffic quality very often took suit. The analysis did not show any other parameters dependent on changes in TH. Thus changes in TH were not dependent on visibility, time of day or weather conditions. However, the long-term study was conducted in the summertime in which only few drives took place in adverse weather conditions (i.e. rain or fog) or at night. The first hypothesis, that drivers adjust their TH according to visibility, time of day or adverse weather could not be justified. Further analysis would be needed in order to verify the tentatively put forward idea that changing of TH is very strongly dependent on type of road and traffic quality – with practically no influence of visibility, time of day or adverse weather.

Over time, most drivers developed a preferred TH. As figures 27 to 29 show, drivers experimented with the different available distances but no extreme was adopted by any driver. This was confirmed by drivers' subjective responses, who reported that at a 1,0 s TH, the distance was too small and often dangerous and that similarly, at a 1,9 s TH, the distance was too large and dangerous due to cars cutting in. All drivers adopted the middle TH of either 1,3s or 1,6 s and mainly only varied the set desired TH between the two. The second hypothesis, that through the adaptation of a preferred TH from the available range, very sporty or very cautious drivers would select opposite extremes of TH settings is rejected.

5.1.3.5 Subjective evaluations

The driver's subjective evaluations were extracted by means of questionnaires and semi-structured interviews. The questionnaires, filled out directly after the testing period were kept fairly general about drivers perceived understanding of the system, feelings of safety, comfort, satisfaction, trust and additional dimensions which are not relevant to this study. The interviews were performed to delve further into certain aspects partly covered by the questionnaires. They were conducted after the analysis had been completed with hindsight of drivers' usage of the system over time, eventual operational strategies and responses to semi-critical situations. The interviews focused in particular on assessing drivers' familiarisation processes to the ACC system as well as confronting drivers about their particular system usage in order to understand and evaluate the reasoning and processes behind their behaviour. Further questions dealt with perceived learning hurdles and drivers' informational needs. Drivers were specifically asked to describe how they would improve the system's interface and what form of online feedback or help they would most benefit from, to effectively and safely learn the ACC system's functionality, operation and limits. One participant was not available for interviewing.

The results presented in this section summarises the main findings. The questionnaire results are complemented by drivers' interview responses. Questionnaire responses are presented in tabular form to quantify the participants' views on their familiarisation and understanding of the system as well as feelings of safety, trust and acceptance. Participants' interview responses can be found in Appendix A.

General understanding

In terms of the system's functionality, participants expressed problems in understanding how close the ACC allows the vehicle to get to the lead car during an approach situation as this varies dependent on the relative speed and the selected TH. Drivers felt uneasy about the system's late reactions during approach situations. Sometimes, drivers worried whether the system was working or not. Drivers also found that the system's reaction time after automatically braking was too long once the way was free again. They reported problems in

the system's inappropriate acceleration or decelerations, as the system does not take account of the context (i.e. overtaking, motorway exits, curves or mountainous drive...). Also, drivers were irritated by the number of vehicles cut-ins during heavy traffic. Moreover, the fact that the system did not react to vehicles driving below 30km/h or to standing vehicle was considered to be an important system drawback. Additionally, the fact that there is no place provided for the right foot was deemed uncomfortable and dangerous if a sudden braking action was required. Finally, irregularities in the functioning of the system and incomprehensible close approaches although a long distance had been set was reported. These problems seemed, however, to be attributable to technical problems with the system and not to the system's functionality. Participants' answers from the questionnaire are summarised below:

How much sense does the system's functionality make?

Scale	Totally nonsensical	Somewhat nonsensical	Not sure	Somewhat sense	Total sense
Participant Nr.			4, 6	2,3	5

Was the functioning of the system (how the speed and distance is regulated)...

Scale	Very difficult to understand	Somewhat difficult to understand	Not sure	Somewhat easy to understand	Very easy to understand
Participant Nr.				2, 5	3, 4, 6

After how many days were you familiar with the system's functionality?

Scale	1 Day	2 Days	3 Days	4 Days	5 Days
Participant Nr.	3, 6	4, 5			2

Towards the improvement of these problems, participants suggestions for a better ACC display interface included:

Display the speed of the lead car so that the driver knows what the relative speed is, and can determine the need for intervening during approach situations.

- Implement an acoustic display when the lead vehicle brakes hard or is decelerating until standstill.

Take away irritating warning tone that is also emitted when no there is no need to intervene.

- Implement feedback that the system is really functioning.
- Permanently display the set distance.

Understanding of system operation

In terms of the system operation, participants expressed problems to develop a feeling for the system's range of application and determining when it makes sense to use the ACC system. Additionally, drivers found that the buttons on the MFS were not sufficiently lit and that they were positioned too far down. Moreover, drivers found that due to the close proximity of the buttons, the risk of accidentally pressing the wrong button (+ instead of – for example) was high. Finally, participants also found that setting or 'programming' the desired TH was too cumbersome.

The operation of the system was...

Scale	Very problematic	Somewhat problematic	Not sure	Somewhat simple	Very simple
Participant Nr.				2, 5	6

After how many days were you familiar with the operation of the system?

Scale	1 Day	2 Days	3 Days	4 Days	5 Days
Participant Nr.	3, 4	5, 6	2		

Understanding and trust in take over situations

In take-over situations, drivers reported late reactions of the system, particularly during hard decelerations of the lead vehicle, in the case of a very slow vehicle ahead or in cut-in situations on the motorway. Further, it was reported that the ACC system sometimes did not detect the vehicle ahead, for example, when a small vehicle was behind a lorry.

The reactions of the system were overall ...

Scale	Mostly incorrect	Sometimes incorrect	Not sure	Often correct	Mostly correct
Participant Nr.				2, 3, 4, 5, 6	

How often could you predict the system's reactions (when the system would intervene)?

Scale	Never	Rarely	Sometimes	Often	Always
Participant Nr.			2, 3, 5	4, 6	

The timing of the system reactions were overall...

Scale	Much too late	Somewhat too late	On time	Somewhat too early	Much too early
Participant Nr.	3, 4	5, 6	2		

Were you worried about an incorrect system behaviour?

Scale	Never	Rarely	Sometimes	Often	Always
Participant Nr.		3, 4, 6	5	2	

Acceptance and comfort

In terms of the effect of ACC driving on normal driving and the integration of ACC driving into the normal driving style, participants reported a greater speed awareness, maintenance of larger following distances and a generally more careful driving style. In terms of the effects of ACC on drivers concentration, the results were mixed between a reported higher level of concentration due to the ACC system limits, and more relaxed, less concentrated driving, especially during platoon driving.

Has your driving style changed through the usage of the ACC system?

Scale	Not at all	Hardly	Somewhat	Considerably	Totally
Participant Nr.		2	3, 4, 5, 6		

After how much time did the collaboration with ACC system and yourself become seamless?

Scale	1 Day	2-3 Days	4-5 Days	6-7 Days	> 7 Days
Participant Nr.	3	5, 6		2, 4	

Informational requirements

Drivers informational requirements in terms of feedback and/ or online help for an effective and safe use of the ACC system was addressed in the interviews. Participants were asked whether they thought an online tutor system capable of giving timely, situation-specific feedback and tips to the driver would help them gain a better grasp of the system's functionality and improve usage safety and comfort.

All participants would like extra information in the car during the use of ACC. System feedback as well as feedback of their own interactions with the system was believed to be an important aspect of a tutor system, with the potential for considerably improving human-machine interactions. Explanations of system functioning and advice in the actual situation was unanimously felt to be the right approach for speeding up learning times, particularly with regards to system limits. It was suggested that the information would be better if brought through the acoustic channel as, especially in these moments, concentration is needed on the road.

Participants expressed their desire towards a tutor system that would not only incorporate the ACC system, but in the same manner, give information and advice on all other information and assistance functions inside the car. It would incorporate speech recognition and an interactive display with dialogue capabilities. If the driver's performance is sub-optimal, the

system would automatically correct the driver's behaviour. Acoustically, the system would explain the functions inside the car and how they work. The driver could 'communicate' with the system by answering with a simple yes or no.

5.1.4 Discussion

Through the analysis of a long-term field study of the use of ACC, thorough understanding of the usage of the system and of the problems experienced in various situations was gained, in particular with regards to aspects related to the operation of the system, reactions to system limits and of its usage in varying environmental conditions.

Based upon the long-term interactions, drivers learning of the system's functions and operation, the system limits and the scope of the system application was analysed. While the system's functions are learnt explicitly, relatively fast, through declarative knowledge of the system, the system limits are mostly learned implicitly with experience. The time span, largely dependent on the gathering of sufficient experience necessary to reach expertise is therefore considerably shorter when considering the operational and overall functionality elements of the system compared to the situation specific limits of the system.

These aspects of the drivers' learning task were quantitatively evaluated through drivers long-term interactions with the system and qualitatively through questionnaires and interviews. The analysis led to the identification of learning aims for the usage of an ACC system. Learning aims are understood here as being "the achievement of an efficient and errorless behaviour at the end of the learning process, for the dimensions of interaction with the system for which learning must be effectuated by the driver". These aims are specific to the ACC system but are also generalisable to other driver assistance systems (Simon & Kopf, 2001).

1. Learning to operate the system.
2. Learning the system functionalities i.e. system reactions dependent on the system status or the environment.
3. Learning the application range of the system .
4. Acquisition of explicit knowledge.
5. Development of the system's settings towards a greater subjective usability.
6. Learning the situation specific system limits.
7. Integration of the system in one's own driving style.

As seen from the graphs and the analysis results, a learning process was observed. The stages of the system's use and of the drivers learning progress are not only determined through objective analysis but also justifiable through subjective analyses. Although there is uncertainty in the literature about whether quantitatively measurable stages in learning are discernable, the results seem to show some support for the three learning stages, as mentioned

in the introduction, categorised by Anderson (1993). The analysis of drivers interaction behaviour has shown that drivers interactions with the system progress with experience and that knowledge of the system is quantitatively different once a repertoire of ‘condition-action’ rules has been accumulated and formed compared to when he/she is still learning. This progression through the stages, different for each driver, might, however, also be attributable to drivers individual levels of technical affinity, motivation, trust, locus of control, time between each drive, length of drive or reason for driving (e.g. holiday or business), or to any combination of these factors.

The analysis of the learning aspects derived from drivers’ interaction with the system enabled an objective classification of observable behaviours from which different levels of skill can be interpreted. In the case of de-activating the system with the I/O button, for example, usage of the button can imply a knowledge of the system that might extend beyond the declarative knowledge the driver needs to know (that it has the same function as applying the brakes). Use of the I/O button in flowing traffic, for example, might show an intricate understanding and ability to predict system limits as well as the integration of the ACC system into the driver’s own driving style. The analysis of take-over situations demonstrated the high frequency of their occurrence and the correspondingly high number of associated ‘panic braking’ reactions. These reactions show the difficulty in gaining a full understanding of the system and of developing a feeling of the inherent system limits.

Overall, the results outlined interaction difficulties at the manoeuvring, operational and strategical levels with the system. These were respectively, largely associated with the system’s limits, operational usage, and it’s use in particular environmental conditions. The main learning hurdles can be broadly summed up into four main problematic areas, ordered in terms of safety criticality:

- Take-over situations when system limits are reached.
- Use of the system in various potentially troublesome environments i.e. type of road or adverse driving weather conditions: poor visibility, rain, snow and fog.
- Operational usage of the system.
- Missing or faulty explicit knowledge.

The fourth category ‘missing or faulty explicit knowledge’ was added as even after a considerably long period of usage, some of the functionalities of the system, as well as misconceptions of the system’s capabilities remained (i.e. four different selectable distances). Further, as it is drivers behaviour during the learning process that is aimed to be improved and learning process shortened, initial information for un-experienced users is necessary to improve the accuracy and increase the amount of drivers explicit knowledge.

The main difficulty in analysing a field study is often to keep all parameters constant. With regards to the analysis, all controllable parameters were held constant although, due to the explorative nature of the study, numerous individual parameters such as the ones mentioned above could not be accounted for. Nonetheless, the results indicate clear tendencies of usage, usage patterns and overall, a long and sometimes critical learning stage. In order to generalise and validate the results, however, a much larger sample size would need to be used. The study shows a very individual picture of the strategies and learning process. A major contributor towards individual learning processes is the uncontrollable succession and frequency of traffic scenarios in the field. Another contributor, however, is not externally controlled but internally. Drivers' learning of the system is self-paced. This means that depending on their propensity towards risk, they will explore the limits of the system at different rates. Consequently, controlled learning can either precipitate or delay the successful acquisition of a situative model and greater subjective usability. The individual learning process needs to be addressed in context. When learning to drive with ADAS, the required learning needs to be effectuated whilst driving as the knowledge is acquired as a function of the activity i.e. it is situated.

Thus, appropriate and timely feedback, individually adapted to drivers' experience and learning stage might ameliorate and quicken the acquisition of knowledge and the development of skill, if anchored to specific situations in real time.

The intention of the explorative study in terms of the learnability of ADAS was to compile the development for an approach to driver assistance systems that minimise the learning demands and eliminate learnability issues that can result in safety-critical traffic situations. The results led to the development of an individualised online tutor system aimed to increase system comprehensibility and predictability by responding to the difficulties met by users in the actual situation, as well as reducing possible negative consequences of users' reactions to the system and adapting the information to the drivers' experience.

6 EXPERIMENTAL STUDIES

6.1 Driving Simulator – Learn-adaptive online tutor system

6.1.1 Introduction

After analysis of the ACC system's usage, it is evident that intricate use of the system is not without its problems. In this section, a solution towards the basic vision of a learn adaptive, "self-explaining" ADAS, is described. By converting the content of the outlined problematic categories uncovered in the long-term field study into four 'help categories', the proposed learn-adaptive embedded tutor offers a solution to reduce the number of critical take-over incidents, improve drivers situative understanding and optimise operation of the system during the learning process.

The learning framework in which the system was developed was adapted from the cognitive apprenticeship theory. Apprenticeship learning embeds the learning of skills and knowledge in their social and functional context, emphasising the contextual variable in the learning process. Learning of driver assistance systems such as the ACC system is effectuated whilst driving, thus knowledge is acquired as a function of the activity and context in which it occurs (i.e. it is situated). Learning was thus anchored to specific situations in real-time, aiding reflection, transfer and a more rapid process towards proceduralisation (Cognition and Technology Group at Vanderbilt, 1993).

The core teaching methods - modelling, coaching and fading - of the cognitive apprenticeship method, designed to help learners acquire an integrated set of cognitive and metacognitive skills through processes of observation and of guided and support practice (Collins et al., 1989), formed the frame of reference for the online tutor system.

In cognitive domains, modelling requires the externalisation of usually internal (cognitive) processes and activities. The theory maintains that making knowledge as much as possible explicit knowledge creates an implicit understanding of the system. To this aim, by means of the speech output module, the system makes explicit the basic ACC functionalities such as the switching between operation modes (regulation of the distance held as well as conventional cruise control modes) or makes explicit situations which could represent difficulties for the driver or explain why it did not react as expected in certain circumstances (e.g. take over situations).

Coaching consists of observing the driver while they carry out a task and offering hints, feedback, reminders aimed at bringing their performance closer to expert performance. Coaching focuses on the enactment and integration of skills through highly interactive and

highly situated feedback and suggestions; that is, the content of the coaching interaction is immediately related to specific events or problems that arise as the driver attempts to carry a task (Collins et al., 1989). In other words, the driver is given help or advice in effectuating the task at hand. This might consist of various operational difficulties the driver experiences (i.e. acknowledging and understanding the difference between the activation levels of the system – standby or active modes) or reminders of a more effective use of the system (i.e. on different types of roads, weather conditions, or the use of the +/- button instead of the resume button to set the actual speed as set desired speed).

Fading consists of the gradual removal of support until the learner is on his or her own. This may be learner controlled or system controlled. Although a pre-determined performance level whereby a consistently high level of performance is recorded could automatically cancel the situated feedback, one of the study's aims was to gain an insight into the amount of situation-specific feedback that is required or desired by drivers, thus the drivers themselves, based upon their own perceived subjective performance ability could determine the necessity of more feedback and information to perform the task effectively. The driver has the option to discard each situation-specific feedback, hint or advice individually which gives him or her the opportunity to hear it as many times necessary until it is understood and no longer desired. The idea behind it being that individual speech outputs will only be discarded when the corresponding situation or operation has been thoroughly understood.

As outlined above, the main difficulties outlined from the analysis of the long-term ACC study regarding the usage of the system can be categorized into four core areas (see 5.1.4). On this basis, four general user-centred goals were outlined:

- Reducing the number of encountered high demand 'taking-over' situations.
- Obtaining a clear situation-specific understanding of the system.
- Achieving an optimal level of interaction with the system.
- Increasing the amount of drivers' explicit knowledge of the system.

The first goal, to reduce the number of encountered high demand situations implied, in the first instance, a practical definition of these situations. Most of these situations, corresponding to the system's inherent limits, were derived from the main situational difficulties expressed by the five participants of the long-term study. The limits of the system can be characterised by the technical limits of currently available radar sensors for series production and the implemented braking and accelerating capability restrictions of the system. The limited far-range sensing capabilities, for example, will make the approach to a vehicle at very high difference velocity a high demand situation, requiring the driver to take-over the control. Further, the cone shaped nature of the radars results in late recognition of close range cut-ins

from other vehicles and creates potential difficulties when a detected target is 'lost' in a curve or a target is only detected very late in a curve. On the basis of these situation characteristics, algorithms can be deduced to identify and filter, in terms of registered car data values, the 'experienced' situation and determine the a-posteriori explanation needed by the driver to build a successful model of the system's behaviour.

The second goal of the tutor help-system aims to optimise the use of the ACC system with respect to safety in particular environments and environmental conditions. Combined data from the GPS, from the light sensors, rain sensors and the 'operational use' of the system is transferred to the tutor module which, in turn, issues the appropriate advice, explanations and support to the driver when inappropriate usage of the ACC system is detected dependent on road type, traffic conditions, night time and in particular weather conditions such as fog or heavy rain.

The third goal, to achieve optimal operational usage of the system, entails the achievement of an efficient, effective, 'error free' usage of the system in minimal time. The difficulty of defining the criteria for optimal usage due to its subjective nature, advocated the need for an analysis of participants' operational 'learning curves'. Dependent on drivers' learning progress, the system will correspondingly adjust the explanations to be issued. Additionally, the content of speech outputs varied according and to whether the situation was experienced for the first time or consequently thereafter. Criteria used for identifying the actual learning state of the driver are, for example, errors committed, behaviour in specific encountered situations or the help messages already put out. Explanations of the specific function of each button is automatically triggered upon detection of experienced operational difficulties. The order in which outputs will be issued through the multimodal tutor interface are prioritised, according to the learning state, usage pattern of the driver and, of course, the 'status' of the ACC system.

The fourth goal was to ensure the functional principles of the system were grasped during the early interactions with the system as well as to avoid misconceptions of the system's capabilities. To increase the amount of drivers explicit knowledge during early usage of the system a brief introduction of the system was issued upon first usage. Further, drivers would be explicitly informed of a change in the system's functioning modes and be issued accurate functional descriptions in situations posing potential system de-activation.

To this aim, the ACC system was equipped with an additional tutor module, capable of issuing individual hints and explanations according to the driver's learning state and the current traffic situation. The structure of the embedded tutor module is shown in Figure 26.

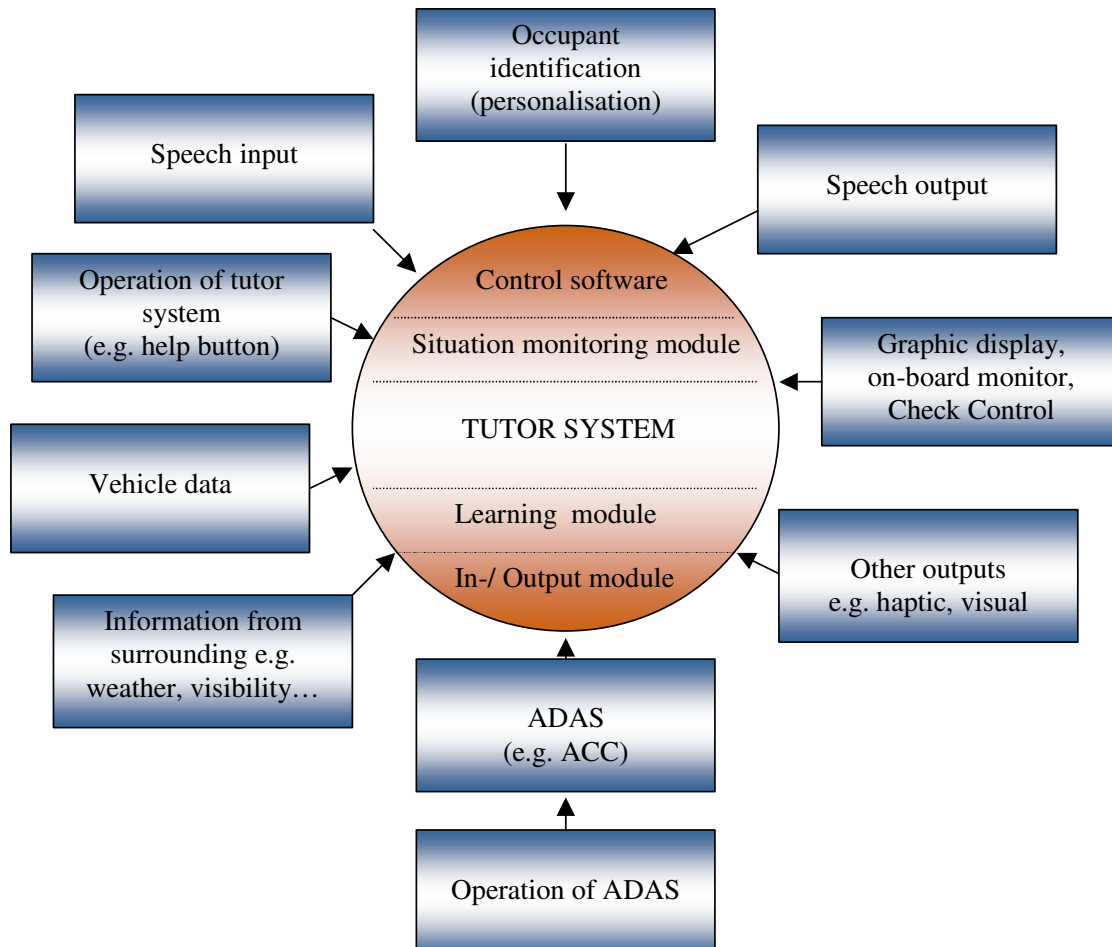

Figure 26. Structure of the embedded tutor module

The embedded on-line tutor combines the information from the CAN-BUS (supplying vehicle data like velocity, activation of controls etc.), Global Positioning System (GPS), light and rain sensors, ACC MMI operations and the system's current state to disclose timely and personally adapted feedback. Additionally, a situation monitoring module was integrated, able to detect the situations in which the limits of the system are reached. The ACC tutor system further comprised of a multimodal human-machine interface (HMI), incorporating both a display and a speech input/ output module to enable the most natural, simple human-machine interaction. The tutor used speech output as the main feedback source. It provides additional explanations in lieu of incomprehensible or confusing situations. Upon first usage, for example, a short introduction of the most important information regarding the functionality, operation and liability of the ACC is issued, replacing the need for additional explanation by means of a written manual.

The analysis of the recorded sensorial data of the ACC-vehicle used in the long-term study enabled the specification of traffic situations posing potential difficulties for users. The traffic situations have been clustered into categories. Each of the following categories consist of a number of specific situations for which the corresponding, timely feedback can be issued. Each situation is detected in real time from the vehicle data and vehicle surrounding modules and identified through programmed filters based upon the sensorial data of the experimental vehicle used in the long-term field study. This formed the basis of the situation detection module (Gerisch, 2001), which enabled the timely release of information and feedback. Table 7 includes a description of the situations categorised into the four help categories as well as the corresponding speech output, true to the BMW in-vehicle ACC literature (ACC, 2000), from the tutor system. Each situation was assigned a number corresponding to the appropriate sound sample of the feedback output. In the event that no situation was detected, the number 1 was attributed, if the actual speech output was discarded, the number 0 was attributed.

Table 9. *Automatically detected situations and corresponding speech samples, categorised into four help categories*

Help category 1: „Functional principle“		
Sit. No.	Situation description	Speech output from tutor module
10	Introduction to the ACC system	“The Active Cruise Control ACC enables you to select a speed which the car will then maintain automatically. If you come up behind a slower vehicle, the system will adjust the speed and the distance to it. As driver of the vehicle you still have the sole responsibility for the vehicle. ACC is operated with the buttons on the right-hand side of the steering wheel.”
11	The ACC system is regulating the speed	“No vehicle in front of you is detected, ACC is working like a cruise control.”
12	The ACC system is regulating the speed and the distance	“A vehicle is detected in front of you, ACC is now regulating the distance. This is shown by the yellow ‘object detected’ light in the instrument cluster.”
13	Warning of a cut-in situation	“This cut-in situation could go undetected by the ACC system.” - Brake parameter 1: “...ACC could have managed here.”
14	Warning of an approach at a high relative velocity	“You are approaching a slow vehicle at a high speed. ACC might not be able to manage because of the high difference in speeds.” -Brake Parameter 1: “...ACC could have managed here.”
15	Warning of a lead car	“The vehicle in front is braking hard. ACC might not be

	braking hard	able to compensate for the high deceleration.” -Brake Parameter 1: “...ACC could have managed here.”
16	Warning of a sharp curve with loss of object detection	“This curve is too sharp for the ACC system. The car in front was no longer detected.”
17	Approach to a very slow vehicle	“You are approaching a very slow vehicle. If it came to a stop, ACC could no longer detect it.”
18	Unnecessary intervention during slight changes of the lead car’s speed	“ACC can easily handle the changes in speed of the car in front.”
19	Drive through curve without loss of object detection	“In a similarly sharp curve, the car in front might no longer be detected by ACC.”

Help category 2: „System operation“

Sit. No.	Situation description	Speech output from tutor module
20	First use of the “resume” button	“You have pressed the resume button. ACC now maintains the actual speed. You can also switch on ACC with the +/- button.”
21	Repeated use of the “resume” button	“The resume button takes over the last selected speed. This is indicated by a green LED in the speedometer.”
22	First use of the +/- button	“You have pressed the +/- button. ACC now maintains the actual speed. You can also switch the ACC on with the resume button.”
23	Repeated use of the +/- button	“The +/- button sets the actual speed which is indicated by a green LED in the speedometer.”
24	Increased speed (“+” button pressed)	“You have increased your set speed.”
25	Decreased speed (“-“ button pressed)	“You have decreased your set speed.”
26	Use of the I/O button to turn the ACC system on	“You have activated the ACC system. The system is ready to operate as shown by the green light in the instrument cluster.”
27	Use of the I/O button to turn the ACC system off	“You have de-activated the ACC system”.
28	Use of the I/O button to de-activate the system	“You have switched off the system’s functions. ACC is ready to operate.”
29	De-activation of the system by applying	“By braking, you have switched off the system’s functions. ACC is still ready to operate.”

	the brakes	
30	Operation error: another button pressed instead of I/O button	“To activate the ACC system, press the I/O button.”
31	Operation error: „resume” instead of +/- button	“The speed set by the resume button was lower than the actual speed. In this case, pressing the +/- button would have been more effective.”
32	Overriding the system through the accelerator pedal	“You can override the ACC system at any time by pressing the accelerator pedal.”

Help category 3: „System limits“

Sit. No.	Situation description	Speech output from tutor module
40	Sharp curve, object comes out of detected range	“Due to a sharp curve, the vehicle in front was no longer detected. It was good that you intervened.”
41	Incorrect detection in the approach to the curve	“ACC identified an incorrect target when approaching to the curve.”
42	Lead car decelerates <30km/h: ACC switches off automatically	“The vehicle in front is decelerating below 30km/h, ACC automatically switches off at 30km/h.”
43	Cut-in situation	- Brake parameter 1: “The system could have managed this cut-in situation.” - Brake parameter 2: “It was important that you intervened in this cut-in situation.”
44	Approach with high relative velocity	- Brake parameter 1: “The system could have managed this approach.” - Brake parameter 2: “It was important that you intervened during this approach.”
45	Braking of the lead car	- Brake parameter 1: “The vehicle in front braked hard. The ACC system could have managed.” - Brake parameter 2: “It was important that you intervened. The braking capacity of the ACC system wouldn’t have been sufficient.”

Help category 4: „Range of application“

Sit. No.	Situation description	Speech output from tutor module
50	Poor visibility	“In poor visibility, the ACC system should be switched off as a timely intervention cannot be warranted.”

In the following table, the dynamic driving situations programmed for detection by the system are listed. The situations with the numbers 13-19 were detected in real-time, whereas the highlighted situations were detected after intervention from the driver and often represent the occurrence of a semi-critical situation. The term „critical situation“ must be used with precaution as its meaning is often associated to a subjective evaluation (Mock-Hecker, 1994), therefore, the subjective perception of a similar situation might be different for different people. Further, in the literature, no standard single definition has been given to the term. Nadjm-Therani (1990), for example, has defined it as being any deviation from a safe driving behaviour, whilst Kuhlmann (1981), defined it as being any situation which entails the danger of having an accident. Here, the term „semi-critical situation“ is used in the sense defined by the following definition:

“A critical traffic situation is a traffic situation in which an intervention is necessary to avoid the danger of an accident, or at least to lower the chances of it happening.” Definition adapted from (Mock-Hecker, 1994).

Table 10. *Detected situations in dynamic conditions*

Situation No.	Situation description
13	Warning of a cut-in situation
14	Warning of an approach at a high relative velocity
15	Warning of a lead car braking hard
16	Warning of a sharp curve with object out of detection range
17	Approach to a very slow vehicle
18	Unnecessary intervention during slight changes of the lead car’s speed
19	Drive through curve without the object coming out of the detected field
40	Sharp curve, object comes out of detected range
42	Lead car decelerates below 30km/h, after which the ACC system switches off automatically
43	Cut-in situation
44	Approach with high relative velocity
45	Braking of the lead car

The situations listed in Table 10 represent the ACC system limits which the situation detection module is able to detect in real time. The conditions necessary for the automatic detection of the situations are described in Appendix B. Central to the appropriate and timely issuing of feedback in terms of criticality of the traffic situation, is the ‘necessary

intervention' parameter. This parameter calculates, after the detection of a lead car, the deceleration rate necessary to adapt the same speed whilst maintaining a (very small) distance behind it. In the occurrence of a braking manoeuvre by the lead car, the necessary intervention parameter is automatically updated as a direct effect of the change in the rate of the lead car's deceleration. The necessary intervention parameter was calculated as follows:

$$a_{nec} = \frac{(v_{own} - v_{lead}) * (v_{lead} - v_{own})}{2 * d_{det}} + a_{lead}$$

where:

- d_{det} = Distance of own vehicle to lead vehicle
- a_{lead} = Acceleration of lead vehicle
- v_{lead} = Speed of lead vehicle
- v_{own} = Own speed

At the same time, the system will determine whether the capabilities of the ACC system will suffice to handle the detected traffic situation. This is determined by the so-called 'brake parameter'. Like the situation number, it is also measured every 10ms and is linked directly to the issuing of the appropriate inforamory sound samples. During the warning of the presence of such a situation, two values can be administered:

Brake parameter = 0: No feedback is given about the system capabilities

Brake parameter = 1: System capabilities can handle the longitudinal control

Thus, a grey zone exists in tight situations in which no feedback is given about the system's ability to handle the situation. This decision task, in "50/50" situations was deemed to be important for drivers to learn the braking capacities of the ACC system quicker but also to avoid any 'blind trust' in the system to settle.

The 'brake parameter' is construed on the basis of the 'necessary deceleration rate'. If the absolute value of the deceleration is smaller than the offset point the brake parameter is set to 1, otherwise, it remains 0. If the brake parameter is not used further during the same situation, it then remains 0.

The tutor system not only gave advice regarding the criticality of the actual or imminent traffic scenarios but also gave immediate feedback to drivers' on their actions. Central to the reactive characteristic of the tutor is the classification of the brake parameter into necessary and unnecessary interventions. On the basis of the calculated necessary intervention parameter, the brake parameter is determined. Two values can be administered:

Brake parameter = 1: Longitudinal control could have been effectuated by the ACC

Brake parameter = 2: Driver intervention was necessary

If the absolute value of the necessary deceleration is smaller than 1.9m/s^2 , the system could have handled the situation and the brake parameter 1 is set and the corresponding feedback is emitted. If the absolute value of the necessary deceleration was greater than 1.9m/s^2 , the brake parameter is set to 2 and the corresponding reinforcing feedback is emitted.

In chapter three, the multiplicity of factors that need to be taken account of when automating the driver's task were discussed. It was argued that although many of the problems and high-risk situations stemming from the implementation of ADAS may be a result of automation, the problem is not automation per se but rather the inappropriate design and application thereof.

In designing an automatic system to control part of the driving task, the system is usually considered complete when it functions as requested. Providing feedback and monitoring information to the driver is usually regarded of secondary importance. Feedback is essential, however, as the systems are not capable of handling all possible situations and because unexpected events do arise, especially when dealing with the complexity of the driving task within the driving environment. Drivers need to cope with unexpected situations and this is why feedback and 'conversation' is required. When drivers perform actions, feedback is essential for the monitoring of those actions, to allow for the detection and correction of errors and the development of appropriate responses. Without appropriate feedback, people are indeed out of the loop: they may not know if their requests have been received, if the actions are being performed properly, or if the problems are occurring. Feedback is also essential for learning, both of tasks, and also of the way that the system responds to the wide variety of situations it will encounter.

Intelligent systems do not lack of information, at least in the technical sense, that is, the feedback is potentially available, but is not attended properly or at all. The task of presenting feedback in an appropriate way is by no means easy. Many examples exist of how not to inform people of possible difficulties i.e. overuse of alarms in automation and the difficulties caused by having instruments using a sound or buzzer or flash message to warn the operator (Stanton & Edworthy, 1999). What is needed is continual feedback about the state of the system, in a normal natural way. This means designing systems that are informative, yet non-intrusive, so the interactions are done normally and continually, where the amount and form of feedback adapts to the current situation and to the learning stage of the driver.

For the design of the tutor system, the knowledge from previous empirical research from learning environments as well as guidelines on information presentation and warning in the vehicle were closely considered and implemented. Beyond the guidelines for the presentation of information in driving environments and the ergonomic guidelines related to the composition of the acoustic displays in vehicles presented in section 3.4.1.2, some of the main theoretical aspects and principles underlying the presentation of feedback in the tutor system are presented here.

The tutor system, through a continuous measurement of the driving parameters, the surrounding environment and the drivers reactions, is able to provide full and accurate information about the discrepancy between required and achieved performance, what Anderson et al. (2001) asserts to be the key for effective feedback. Feedback was used to increase drivers' declarative knowledge, providing both a broad description of the tasks to be performed and action-specific 'how-to' information, serving as both a motivational function and to fine-tune actions (Anderson, 1993). Feedback was attributed according to instructional principles in the context of programmed instruction (Alessi & Trollip, 1991; Anderson et al., 2001). For example, "prompting" was used in order to shape correct responses by making drivers aware of situations in which driver intervention might be necessary e.g. "The vehicle in front is decelerating below 30 km/h, ACC automatically switches off at 30 km/h" (situation 42 in the system limits help category, see table 6).

In terms of frequency of feedback, many studies reported that the reinforcing effects of KR in strengthening the stimulus-response bond were best served when KR was provided as close to the relevant response and on as many occasions as possible (Kulik & Kulik, 1988; Salmoni et al., 1984; Schmidt et al., 1989) and that any intervening activity would be particularly destructive to learning from feedback (Lee & Magill, 1985; Swinnen, 1990). Bilodeau (1969) even demonstrated that the rate of learning was directly proportional to the absolute number of trials on which KR was provided. Anderson's (Anderson et al., 2001) empirical research on the timing and delay of knowledge of results (KR) supports this view, confirming that feedback only seems to be effective if there is minimal delay between action and feedback.

Thus, information was attributed during the situation or directly afterwards and repeated itself as many times as the situation occurred, for every situation, until it was discarded by the driver.

In terms of content, the information provided was 'learning feedback' (more in-depth knowledge of drivers performance) as opposed to 'action feedback' (immediate notification of the unsuccessful completion of an action). This type of feedback leads to a possible slower learning but also to slower decay of the retention of information, compared to a predicted faster learning rate and a faster decay of skill. The latter type of information was preferred as studies have shown that when performance is evaluated by a long-term retention test,

individuals who received more or better KR performed best during acquisition but typically performed worse during retention than individuals who received less useful KR or have KR gradually withdrawn during practice (Schmidt et al., 1989).

Based upon the evaluation of the long-term study and the learning process associated to the ACC system, this study aimed to test the effects of timely, situated information on participants' interactions with the ACC system. Information from the learning hurdles were implemented into four help categories, consisting of situation specific information and advice in the form of auditory speech outputs. The embedded, learn-adaptive module was implemented in the driving simulator where the scenarios of the field study were reproduced. Participants' usage and learning of the system was analysed in terms of knowledge on system principles (mental model without procedural skills), their ability to apply solutions to different problems and on their ability to generalise knowledge and skills beyond the information provided explicitly by the tutor (mental model with procedural skills).

Hypothesis 1: Participants' interactions with the ACC system will improve by embedding the learning of knowledge and skill in its functional context through situated feedback.

The first experimental hypothesis leads to the directional prediction that anchoring feedback will increase safety at the strategical level by improving drivers' use of the system in less-than-optimum conditions e.g. in poor visibility. At the operational level, situated feedback will reduce the number of operational errors (mode errors and activation errors) and at the manoeuvring level, participants in the tutor group will have lower collision or near collision rates and panic braking reactions. Thus, it is presumed that based upon participants' interaction with the system and the situation monitoring module, knowledge in the situation will enable participants to make appropriate and timely decisions with a minimum of operational errors.

Hypothesis 2: Issuing learning feedback of the system's actions and reactive feedback on participants' actions will keep drivers in the loop and improve interactions at the manoeuvring level.

The second hypothesis leads to the directional prediction that especially at the manoeuvring level, where experience is required to learn a set of condition-action rules to the system's limits, participants in the tutor group will benefit from getting in-depth knowledge of the system's actions and functioning modes as well as from the reactive feedback of their performance. It is predicted that participants in the tutor group will have a better ability to predict the need to intervene when system limits are reached compared to the participants in

the control group. This will be observable in the higher rate in hits and correct rejections in participants' interventions in curve situations as well as in approach and lead vehicle braking situations.

Hypothesis 3: Through a didactic instructional design adapted from cognitive apprenticeship, knowledge is made explicit which enables participants to gain a quicker implicit understanding of the system.

By adapting information and amount of feedback to participant's experience and actual learning stage, the tutor system will provide participants considerable information during the learning phase of the ACC system and the environment tutor system. The third hypothesis leads to the directional prediction that through frequent explicit feedback, participants in the tutor group will be able to update their system image more frequently than the participants in the control group thereby accelerating their learning progress from a cognitive phase towards a stage of automaticity or proceduralisation. This will be observable from participants' stronger subjective feelings of trust, understanding and safety in the tutor group as well as a more comprehensive knowledge of the system's scope of operation and limits.

6.1.2 Methodology

6.1.2.1 Design

A 4 (scenario) x 2 (display) mixed design was used. The related measures independent variable was the scenario type. The unrelated measures independent variable was display type.

Each of the four scenario types—cut-in, approach to a lead vehicle, decelerating lead vehicle and curve scenario—were attributed two to three levels. Each display type was analysed separately at each level of the scenarios. The scenario cut-in, constitutes of two levels ($d = 40$ m and 60 m); approach to a lead vehicle scenario, constitutes of three levels ($v_{diff} = 30$ km/h, $v_{diff} = 50$ km/h, approach to a standing vehicle); decelerating lead vehicle scenario constitutes of three levels ($a = -1,5$ m/s², $a = -4,0$ m/s², deceleration of lead car <30 km/h) and the curve scenario, constitutes of two levels (loss and no loss of object detection).

Display type had two levels: ACC standard display and ACC standard display with tutor module.

Half of the participants were attributed to the tutor group and half to the control group. The study compared the ability of participants in the tutor group to operate the ACC system effectively but also optimally in different conditions as well as their ability to predict and deal with difficult situations against the ability of participants in the control group.

Independent variables

The levels of each of the four scenario types were chosen so that one level was non-critical, remaining within the regulating capabilities of the ACC system while the other(s) was beyond the system limits, in which participants must actively intervene. The levels of each scenario type are explained below and summarised in Table 11.

In the cut-in scenario, two levels of cut-ins were chosen while the ACC vehicle is overtaking a platoon. During a cut-in at a distance of 40 metres to the ACC vehicle, the driver must intervene as the cone-shaped radar sensor detects the cut-in vehicle too late for the system's braking capacity to handle the deceleration unassisted. At a distance of 60 metres, the radar sensor is able to detect the cut-in vehicle in time so that a driver intervention is not necessary.

In the scenario approach to a lead vehicle, three levels were chosen. At a relative speed difference of 30 km/h, the system's decelerating capabilities can handle the situation. However, an approach to a lead vehicle with a relative speed difference of 50 km/h is in excess of the system's capabilities, in which case, an intervention of the driver is necessary. The third level is the most extreme case of approach situations. The approach to a standing vehicle, such as the tail of a traffic jam, always requires driver intervention as the system does not react to standing objects.

Three levels were also chosen in the decelerating lead vehicle during car-following scenario. At the first level, a mild deceleration was executed by the lead vehicle ($-1,5 \text{ m/s}^2$) which the system can cope with. At the second level, the sudden deceleration $-4,0 \text{ m/s}^2$ of the lead vehicle is beyond the system's own decelerating capacity. At this level, a driver intervention is necessary. The third level is a deceleration of the lead vehicle below 30 km/h. This level distinguishes itself from the previous levels as the ACC system automatically switches itself off below a speed of 30 km/h. Thus, at this level, a driver intervention is always necessary.

In the fourth scenario, two levels of the scenario steep curve in follow-mode were chosen. In one level, the lead vehicle remains in the sensor range in the curve. At this level, no driver intervention is necessary. At the other level, the lead vehicle goes undetected due to the sharp curve radius, thus maybe necessitating driver intervention.

All the levels of the traffic scenarios represent category B situations - situations which require more learning with experience, in which driver intervention is sometimes necessary (see section 5.1.3.3). The third level of the approach scenario and of the decelerating lead vehicle scenario, however, are category A situations - situations which the system is not designed to cope with, in which driver intervention is always necessary.

Table 11. *Levels of the independent variable ,scenario'*

Scenario type	Scenario level
Cut-in while overtaking a platoon	d = 60 m d = 40 m
Approach to lead vehicle (own and lead vehicle drive with a constant speed difference towards one another)	v_diff = 30 km/h v_diff = 50 km/h Approach to standing vehicle
Decelerating lead vehicle during car-following (following situation with sudden lead vehicle deceleration)	a = -1,5 m/s ² a = -4,0 m/s ² Deceleration of lead car <30 km/h
Steep curve in follow-mode	No loss of object detection Loss of object detection

The experimental drives consisted partly of driving with a preset speed without lead vehicle (ACC maintains a constant speed, similar to regular cruise control driving) and of follow-mode driving. Along the way, situations in which the limits of the system are reached, in which the driver must take over control of the system. During the planning of these critical situations, particular attention was paid towards making their occurrence appear natural. The situations were triggered by different vehicles in a way that drivers could not predict them and did not feel that the situations produced would not occur in real circumstances. As the planning of the situations was made in terms of the most realistic - and within the confines of the available motorway or stretch of road - possible, place for its occurrence, a full randomisation of the situations across all drives was not possible. However, the order in which the scenario levels and the amount of critical situations occurring per drive was kept comparable to avoid confounding the level of difficulty of the presented situations with time.

The independent variable ‘display type’ refers to the different types of interface attributed to participants in each condition. Participants were randomly ordered to the each display condition. Both display conditions featured the standard mode indicators i.e. all the symbols in the ACC standard display are emitted directly in relation to the ACC system status. A green light comes on when the system has been switched on. The green ACC symbol signals that the ACC system is ready to operate using the MFL. The yellow light comes on (vehicle symbol) when a vehicle is detected in front and ACC is working in follow-mode, i.e. it is regulating the speed and the distance to the lead vehicle. The interface of the standard display consisted of the standard ACC soft-sounding auditory signal, simultaneously emitted with the flashing of the yellow vehicle symbol in the speedometer. The vehicle symbol flashes and an acoustic warning is emitted either when a deceleration beyond the immediately available ACC deceleration is required or when the lead vehicle is deemed to be too close to avoid a collision if a high deceleration force was necessary.

The tutor module was connected to the environmental sensors, the vehicle sensors as well as to the ADAS operating controls which enabled to give participants help on the actual traffic situation e.g. danger criticality of the situation and the need for intervention in take-over situations, the current functioning of the system e.g. assistance mode, more efficient system operation e.g. use of the resume or +/- buttons, and environmental conditions e.g. reduced visibility. See Table 9 for all the type of situations in which the tutor assisted the driver and for the corresponding acoustic help outputs.

In addition to the information of the standard interface, participants in the tutor system condition received individual hints and explanations according to their learning state and the current traffic situation. The personalised information and help was continuously updated in accordance to the drivers' actual learning stage. Each situation was attributed a number, as soon as drivers pressed the information button, signalling that they were confident that they had understood the situation thanks to the acoustic help, the corresponding speech output was attributed the number zero. Speech outputs were no longer repeated. At the end of the drive, the numbers corresponding to the speech outputs are saved specific to the driver. At the beginning of the next drive, his or her individual data file is loaded and consequently only the help and advice which he or she did not previously cancel is issued.

The tutor interface was multi-modal, comprising of a visual and a speech input/ output module to enable the most natural, simple interaction between the driver and the tutor system. The graphical display was based upon the availability of information or help. A yellow information symbol was displayed in direct proximity to the standard ACC symbol displays during all acoustic communications with the driver. To stop the current help or advice, drivers need to press the information button (labelled with an i) on the MFS. The information symbol would stay lit for 4 s after the end of the message, enabling drivers to stop the same message being repeated in future. Simultaneous to the information symbol appearing in the speedometer, participants could listen to the help or advice emitted by the tutor module. Users could use the speech command "later" to promptly stop the speech output in the particular situation or press the information button in the MFS to prevent it from being repeated again. Figure 27 displays the positioning of the additional information symbol in the speedometer and the information button in the MFS.

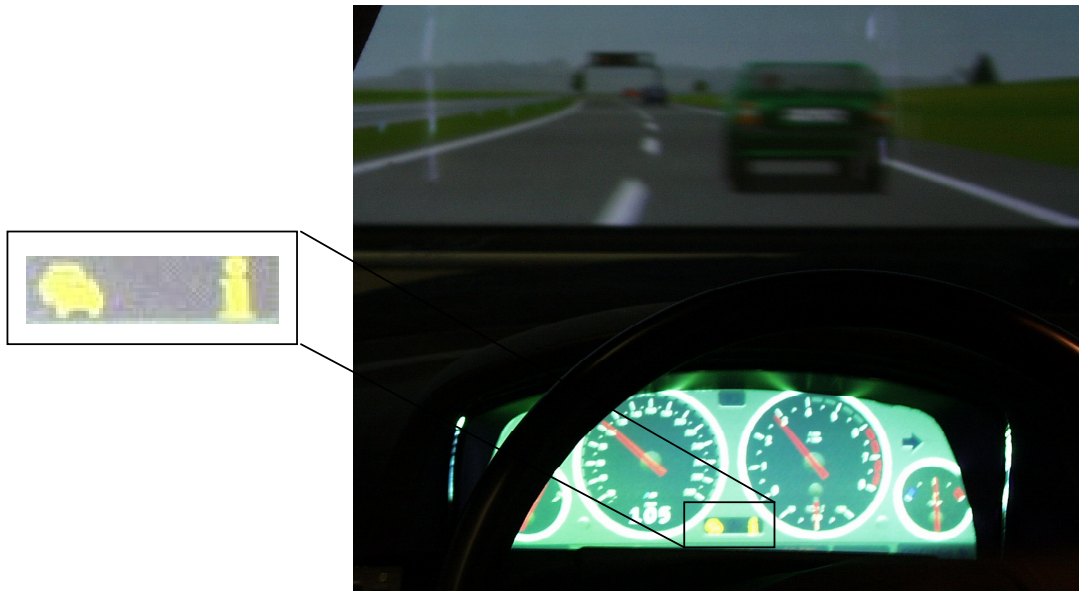

Figure 27. Information symbol of the tutor system

Dependent variables

The dependent variables consist of measures of drivers' interaction with the ACC system in terms of Jordan's (1994) three-component model of usability. The components are guessability, learnability and experienced user performance (EUP). These are associated with, respectively, first time use of a system for a particular task, the number of task repetitions required until an acceptable level of 'competence' is reached, and the relatively stable level of performance that an experienced system user reaches (see section 3.2)

Guessability was tested by the system's operation through the number and type of operational errors and through drivers subjective evaluations of the system. Learnability was measured on the basis of which information outputs were discarded and when the information was discarded as well as whether the moment in which they were discarded corresponded to the established learning of the function. Measures to determine participants' learning of the system also included drivers intervention rates. Learning was measured on the basis of driver's ability to show the correct reactions as well as leaving out incorrect ones for approach situations as well as decelerating lead vehicle and steep curve situations.

Other measures used to determine drivers' performance levels were drivers' maximum deceleration force (m/s^2), a useful measure for determining the number of 'panic braking' situations. Further, parameters related to overall driving performance were measured i.e. speed (km/h), braking force (N), lane maintenance and lane exceedings (TLC). Subjective evaluations was collected by means of questionnaires attributed after each experimental drive.

The dependent variables related to the dynamic car data, to the ACC sensor and operation data as well as to the situation detection and learn modules of the tutor system were recorded

online during the actual drive. During the experimental drives, all variables were recorded at a 100 ms-tact frequency. The output of the tutor module was the information display light in the speedometer, the situation number, the brake parameter as well as the speech sample and speech sample brake parameter. The dependent variables are listed in Table 12. All of the dependent variables were input for the tutor module. The generated data sets were then converted to ASCII format. Subjective evaluations covered subjective changes in comprehensibility in the system's functionality and operation, in understanding the system's limits and ability to predict the need for intervention as well as feelings of comfort and safety.

Table 12. *List of dependent variables*

Dependent variables	
Speed (km/h)	Set desired speed
Acceleration (m/s ²)	ACC status
Time to Lane Crossing (TLC)	Brake force applied by ACC (N)
Steering wheel angle (°)	ACC buttons in MFS
Brake force (N)	Help button
Distance to lead car (m)	Visibility (m)
Speed of lead car (km/h)	Subjective evaluations
Acceleration of lead car (m/s ²)	

6.1.2.2 Participants

A pilot study of 4 participants was conducted to pre-test the occurrence of the programmed situations as well as the situation detection and speech modules of the tutor system. The original sample consisted of 6 males and 6 females, however, due to motion sickness in the driving simulator, one of the female participants dropped out. Half were randomly attributed to each condition. Both groups were kept homogeneous with regards to age, gender and driving experience (number of years since passing the driving licence, number of kilometres driven per year).

The age of the participants ranged from 30 to 57 years ($M = 46,2$) in the control group. The group consisted of 3 male and 2 female participants. The average driven kilometres in the group was 17,400km per year. In the tutor system group, the age of the participants ranged from 31 to 57 years ($M = 42,8$). The group consisted of 3 male and 3 female participants. The average driven kilometres in the group was 20,333 km per year.

All participants were BMW external and held an exceptionally wide range of occupations (from pilot to system administrator and from statistics and mathematics professor to housewife). They were recruited by telephone and selected from the BMW driver database on

the basis of having previous experience of simulated driving in the BMW simulator and of having no prior experience of driver assistance systems.

6.1.2.3 Apparatus

The BMW driving simulator described in section 4.3 was used for this study. Of particular importance was the reproducibility of traffic situations. These events, which drivers encountered were programmed by means of ‘scenarios’ that generate predetermined traffic situations. The company Philosys was commissioned to program the traffic situations in the simulator and to incorporate the tutor system into the overall simulator architecture – so the various drives, displays and the data recording could be started per mouse click by the investigator from the control room.

For the integration of the tutor system, the hardware consisted of an active speaker, positioned neat the middle console, by the driver’s cup holder and a card reader fitted into the radio compartment in the centre stack. The speaker was linked to the SGI-computer, that emitted the speech outputs delivered by the tutor module. The amplitude could be regulated directly by adjusting the active speaker in the vehicle. A card reader was seamlessly integrated into the centre stack in the slot usually allocated to the radio. The card reader simulated the personalisation of the tutor system by registering the driver and reading the feedback history previously emitted by the tutor. When the data was correctly loaded, a red LED turned green on the card reader. In the driving simulator, the personalisation process was realised by entering the allocated driver number at the beginning of each drive. The card reader was, therefore, only programmed to switch the LED from red to green after the card was inserted, however, in this way the personalisation of the system remained as realistic as possible for the participants, see Figure 28.



Figure 28. Implemented card reader in driving simulator cockpit and ACC buttons in MFS

The speech inputs was simulated by the investigator through the use of an intercom system. Upon hearing the commando “stop” or “later”, the investigator would mute the corresponding speech output by simple mouse-click. Any communications between the investigator and the participants during the drives was done through the intercom system and with the help of monitors in a separate observation/ control room.

Both drivers and the road were filmed using two cameras. One positioned on the dashboard for the driver and one on top of the car to capture the entire driving scenery. Both views were condensed onto one screen for a picture in picture effect using a Panasonic view mixer, which blended the driver into the top right hand corner of the screen. This picture was simultaneously recorded by a video recorder Panasonic (AG-6370) which, using a self-generated timecode could then be viewed and directly matched to the data.

6.1.2.4 Procedure

The experiment consisted of three experimental drives and one familiarisation drive. The familiarisation drive consisted of a drive free of traffic, without the use of ACC, in which the participants got accustomed to driving in the simulator. In all drives, both groups drove with the identical ACC system, the only difference was the absence of assistance from the tutor system in the control group.

After the initial welcome, participants were administered a demographic questionnaire covering general person-related and driving experience aspects. Once participants had finished filling out the questionnaire, they received written explanations of the basic functionalities and operation of the ACC-system. Participants read the instructions in their own time. Once participants had finished reading the system explanation, participants

received written instructions for the experimental drive. Once participants had finished reading the instructions, they were asked to get into the car and to make themselves comfortable and ready for driving. Once they had made the necessary adjustments to the seat and mirrors, the key points of the drive instructions were reiterated and any remaining questions they had were answered. The experimental drive began once it was clear that the participant understood what she/ he had to do and had no further questions. For each experimental drive thereafter, participants were given written instructions specific to the drive. Throughout the study, the ACC-system explanations were on the passengers seat for participants to consult if necessary.

Proceeding each experimental drive, participants were administered a questionnaire regarding the tutor module, the ACC-system functionality and operation. The control group received the same questionnaire, only the part related to information and feedback was significantly shorter comprising of only the standard ACC display information. After the third experimental drive, two additional questionnaires were administered. Firstly, a more general questionnaire that covered additional dimensions which were not relevant for the study and thus is not described here, and a “test” questionnaire, intended to establish how much participants had learned about various aspects of the system’s functionality and operation. When participants had no further questions, they were debriefed orally and paid 100€ for their participation. Table 10 gives an outline of the study’s procedure. The ACC explanation, drive instructions and administered questionnaires are shown in Appendix C.

Table 13. *Outline of the study’s procedure*

Drive sequence	Attributed questionnaires and instructions	Duration (min)
	Demographic questionnaire	10
	Learning type questionnaire	
Introduction drive	Drive instructions	10
Experimental drive 1	Drive instructions	30
	Evaluation of ACC tutor system	10
		10 min break
Experimental drive 2	Drive instructions	25
	Evaluation of ACC tutor system	5
		10 min break
Experimental drive 3	Drive instructions	25
	Evaluation of ACC tutor system	
	ACC test questionnaire	15
		Total time 2h 30 min

Description of the experimental drives

The four drives in the study took place on two different courses. The introductory drive and the first experimental drive took place on the so-called A9 course. The second and third experimental drive took place on the Munich 2000 course.

Experimental drive 1

The first experimental drive consisted of motorway driving only. The A9 course represents three motorway segments, the A9, A92 and A99, that form a triangle north of Munich (see Figure 29).



Figure 29. The three motorway segments of the A9 course to the north of Munich

Drivers drove twice around the whole course. Participants were given written instructions to drive with ACC at all possible times and to set a speed of 130km/h on the motorway. Participants were also instructed to abide to the highway code at all times.

Figure 30 shows the situations' graphical location on a birds-eye view of the course. The traffic situations are described in Table 14.

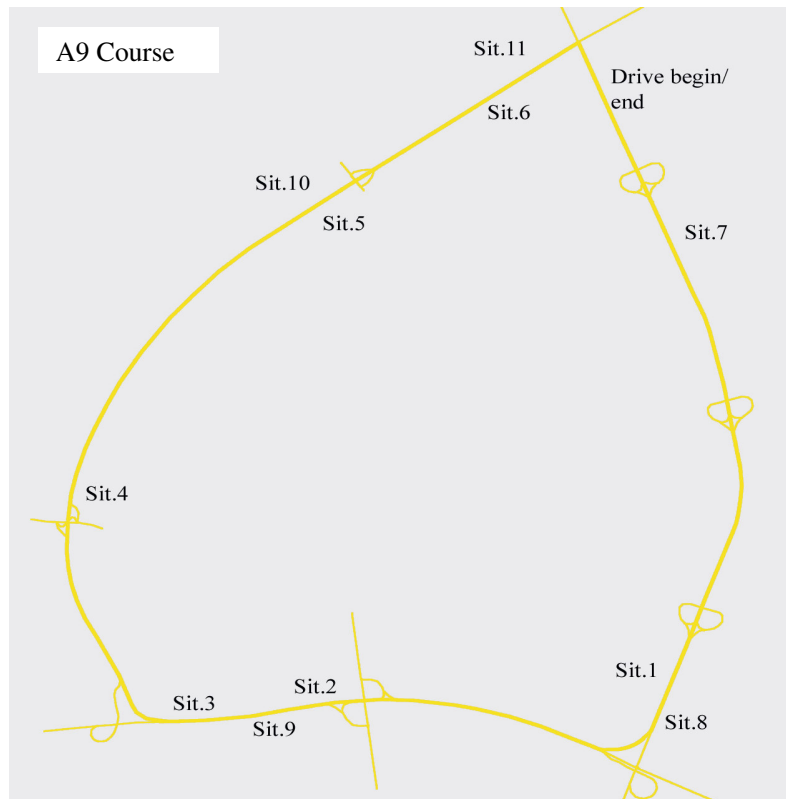

Figure 30. Programmed traffic situation sequence in drive 1

Table 14. Description of traffic situations programmed in experimental drive 1.

Situation	Situation description
1	Participants drive up behind a vehicle, which they follow for a couple of minutes in ACC follow-mode. In intervals, the lead vehicle varies its speed within differences of 30km/h.
2	The lead vehicle overtakes a platoon of four vehicles. Suddenly, a vehicle from this platoon cuts in between the participant and the lead vehicle.
3	In follow-mode, the lead vehicle varies its speed within differences of 30km/h
4	After an open road, the participant approaches a platoon and overtakes it. A vehicle veers closely in front of him.
5	The participant is in follow-mode again behind the lead vehicle.
6	The participant approaches a slow vehicle with a high difference velocity. There is no overtaking possibility as slow vehicles are on both lanes.
7	The participant approaches a vehicle, after an open road, which it follows. The lead vehicle varies its speed.
8	In follow-mode, the participant follows the lead vehicle in a tight curve in which the lead vehicle goes out of the radar range.
9	By overtaking a platoon, a vehicle cuts in, in front of the participant.

- 10 A slow vehicle joins the motorway causing an approach to it with a high difference velocity.
- 11 In follow-mode, before the motorway exit, the lead vehicle suddenly brakes hard.

Experimental drive 2

In this drive, participants were instructed to drive with ACC at all possible times and to set a speeds of 130km/h on the motorway, 90km/h on B-type roads and 60km/h on the inner ring in the city. They were instructed to overtake any vehicles that were slower on the motorway but told not to overtake on B-type roads or in the city. Participants were reminded to abide to the highway code at all times. The navigation of participants within the course was undertaken by the investigator with the help of an intercom system. Figure 31 shows the graphical location of the situations on a birds-eye view of the course. Table 13 describes the traffic situations.

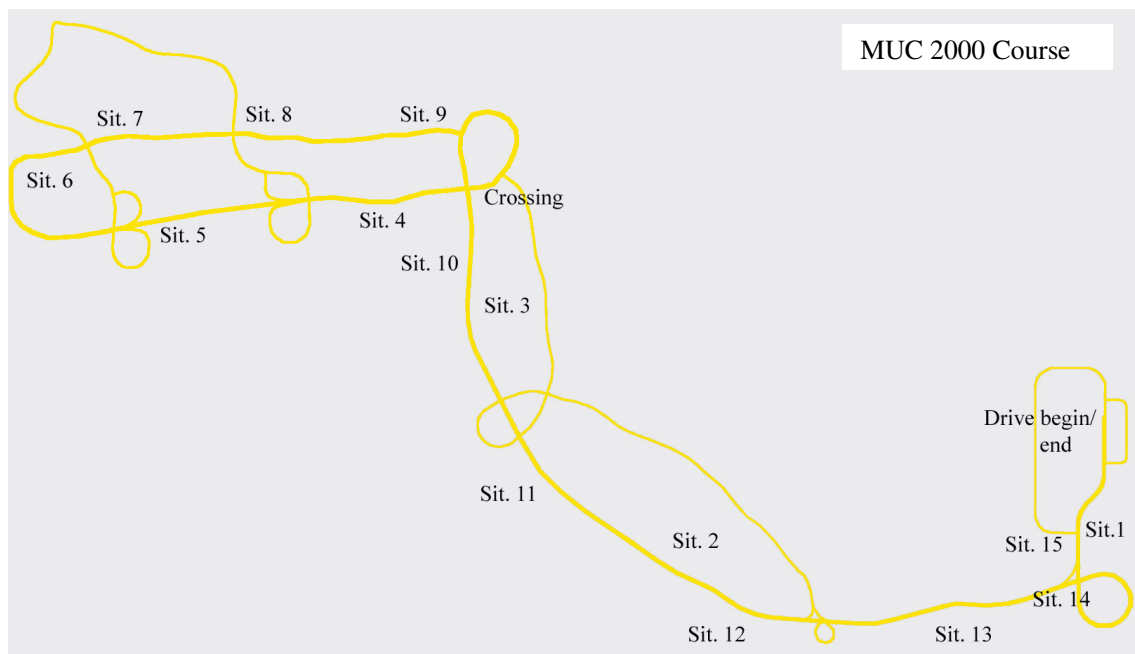

Figure 31. Programmed traffic situation sequence in drive 2

Table 15. Description of traffic situations programmed in experimental drive 2

Situation	Situation description
1	Drivers drove-up to a vehicle which they followed until it turned off to access the motorway. Drivers kept on driving straight on.
2	The driver approaches a platoon which he overtakes. A vehicle cuts into his lane. The driver follows it in ACC follow-mode until it moves into the slow lane and reduces its speed.
3	On an open road, the participant drives into fog. The fog dissipates as the driver

-
- approaches Munich. Subsequently, the driver approaches a crossing with a traffic light.
- 4 After the drive in the city, participants rejoin the motorway. After a short while, participants approach a platoon, from which a vehicle makes a very close cut in.
 - 5 In follow-mode, the lead vehicle varies its speed.
 - 6 Participants exit the motorway and approach a slow vehicle which they stay behind, in follow-mode, in the curve.
 - 7 In follow-mode, the lead vehicle decelerates below 30km/h to a complete stop at a stop sign.
 - 8 Shortly thereafter participants are back in follow-mode where the lead vehicle suddenly brakes hard.
 - 9 In follow-mode, the lead vehicle decelerates below 30km/h to a complete stop at a stop sign.
 - 10 After a major crossing, the driver is back on the motorway, on an open road, and enters another fog bank.
 - 11 The driver approaches a platoon which he overtakes. A vehicle cuts in. The driver follows it in ACC follow-mode until it moves into the slow lane.
 - 12 The participant approaches at a high difference velocity a slow vehicle. There is no overtaking possibility as slow vehicles are on both lanes.
 - 13 Participants exit the motorway. In the curve, the ACC radar detects a vehicle, which it then loses due to the steep gradient of the curve.
 - 14 The lead vehicle brakes almost until a full stop and then turns off to the left.
 - 15 Participants approach a slow vehicle, which then brakes hard.
-

Experimental drive 3

The third experimental drive took place on the same course as the second experimental drive. The instructions were the same as in experimental drive 2.

Figure 32 shows the graphical location of the situations on a birds-eye view of the course. Table 14 describes the traffic scenarios that were implemented.



Figure 32. Programmed traffic situation sequence in drive 3

Table 16. Description of traffic situations programmed in experimental drive 3.

Situation	Situation description
1	Participants drive-up to a vehicle, which they follow onto the motorway.
2	In the curve leading onto the motorway, participants follow the lead vehicle in follow-mode.
3	The driver approaches two vehicles which he overtakes. The first vehicle cuts in into the drivers lane.
4	After the crossing, at which the driver takes a left, he approaches another platoon. When overtaking it, a vehicle cuts in.
5	In a curve, participants approach a slow vehicle and follows it, in follow-mode, through the curve. Afterwards, the vehicle varies its speed.
6	In follow-mode, the lead vehicle decelerates below 30km/h at an empty crossing.
7	Again, in follow-mode, the lead vehicle decelerates below 30km/h at an empty crossing.
8	On an open road, participants approach a standing vehicle at a junction.
9	By overtaking a platoon, a vehicle cuts in very closely in front of the participant before taking the next motorway exit.
10	Participants approach a slow vehicle that is entering a curve.
11	As the curve is very tight, the lead vehicle quickly goes undetected.
12	The lead vehicle brakes to a speed below 30km/h before turning off to the left.
13	Participants approach another vehicle with a high difference velocity.

6.1.3 Results

For a complete evaluation of the effect of the tutor system on drivers interaction and behaviour with the ACC system, the analysis was divided into three parts: the system's usage, acceptance and efficiency.

Acceptance of tutor system was evaluated based on the participant's subjective ratings after each drive. The usage of the system was objectively evaluated through analysis of the recorded data whilst the efficiency of the system was both objectively and subjectively measured. The results are presented within these assessment criteria, beginning with a description of the overall usage of the tutor system in the programmed situations over the course of time, followed by an analysis of drivers' acceptance of the system and an analysis of the system's efficiency in terms of accelerating learning, increasing sustained learning and promoting safer driving behaviour. An alpha level of .05 was used for all statistical tests. The data was analysed using a two-way ANOVA for mixed designs, with drive number (experimental drives 1, 2 and 3) as the related samples variable and display condition as the unrelated samples variable (standard and enhanced display). For the overall comparison of the subjective ratings between conditions, an independent sample t-test was used.

6.1.3.1 Usage of the tutor system

In terms of usage of the tutor system, drivers usage of the situation-specific speech outputs was analysed. It was investigated, in the aim of controlling whether the speech outputs were merely being discarded because drivers found them irritating or whether there existed a trend towards discarding some information but not others (which might be regarded as very useful or important) and ultimately whether the moment in which they were discarded corresponded to the established learning of the function, operation or limit of the system.

Thus, the analysis consisted of determining which speech outputs were discarded as well as when the information was discarded. Beforehand, however, the mean number of issued speech outputs corresponding to the detected situations was analysed for each driver. The speech outputs were categorised into the types of feedback category. The situations with numbers 10-19 represent speech outputs related to the functional principle of the system. The situations with numbers 20-39 represent feedback related to the system's operation. The situations with numbers 40-45 represent information related to the system's limits. Information regarding the ACC system's scope of application had the situation number 50. The speech output corresponding to this category featured twice in experimental drive 2, this is not presented in a graph. See table 10 for a description of the situations and of the corresponding tutor system's feedback.

The help category 'application scope' was left out as it only featured one speech output reduced visibility. Figure 33 shows the mean number of issued speech outputs for all drivers

in the 'functional principle' help category. Figure 34 and Figure 35 show the mean number of issued speech outputs for all drivers in the system 'operation' and 'limits' help category respectively.

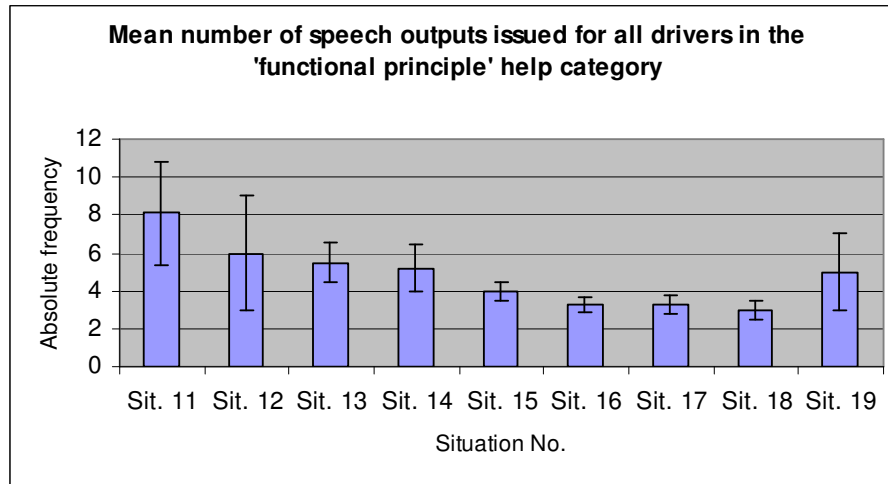

Figure 33. Mean number of speech outputs issued in the 'functional principle' help category

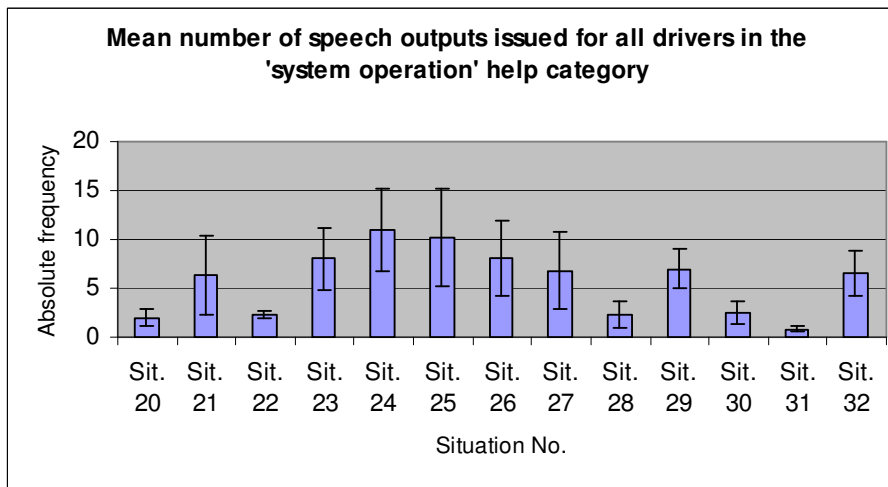

Figure 34. Mean number of speech outputs issued in the 'system operation' help category

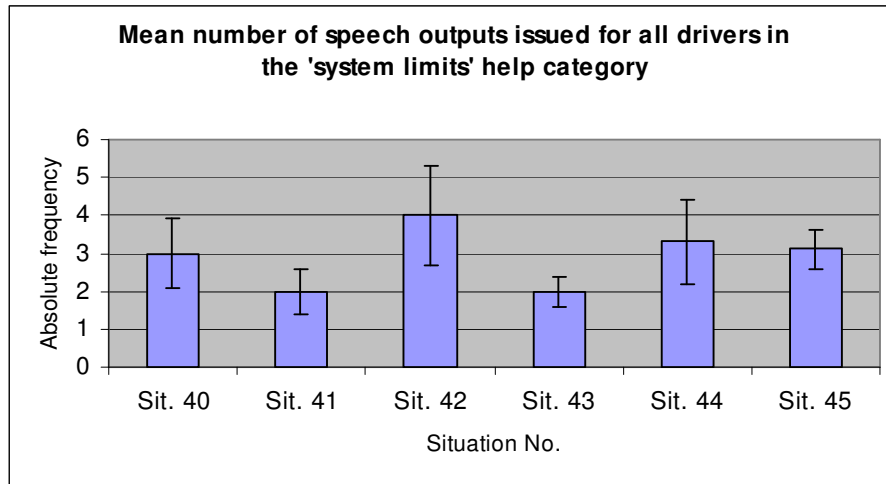
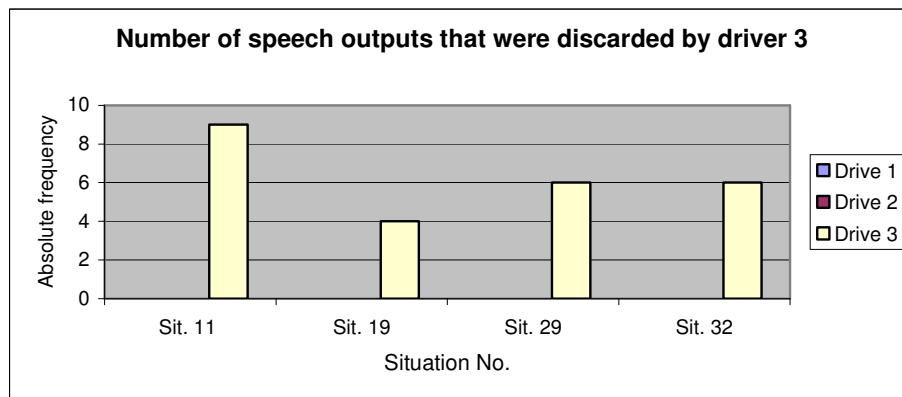
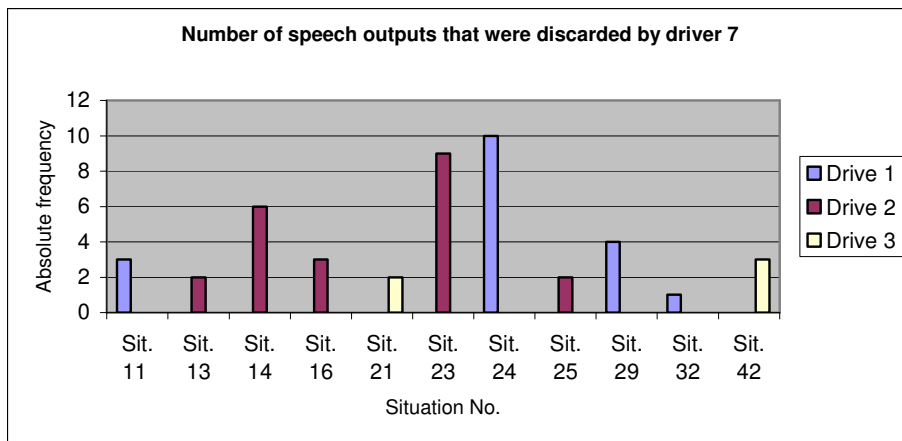
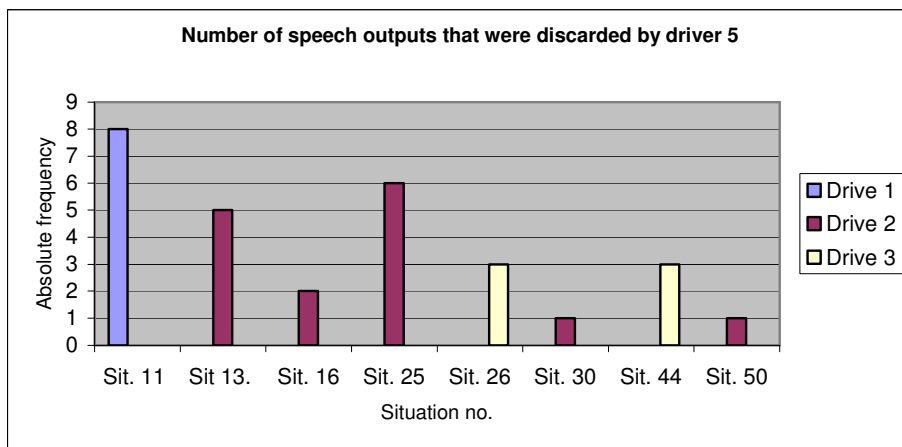
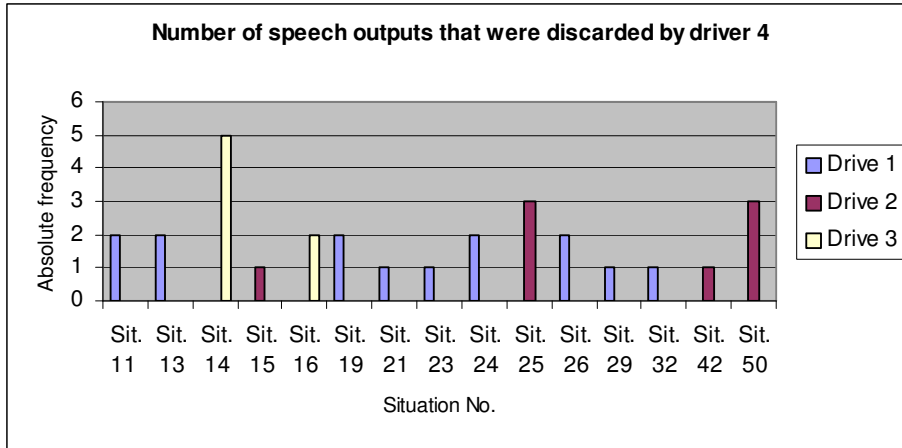

Figure 35. Mean number of speech outputs issued in the 'system limits' help category

Figure 36 shows the absolute number of speech outputs for each driver that were heard before being discarded. The speech outputs are categorised in terms of the help category to which they belong. The drive number in which they were discarded is marked by the different colours. Only five graphs are shown as one participant (driver 6) did not discard any speech outputs.





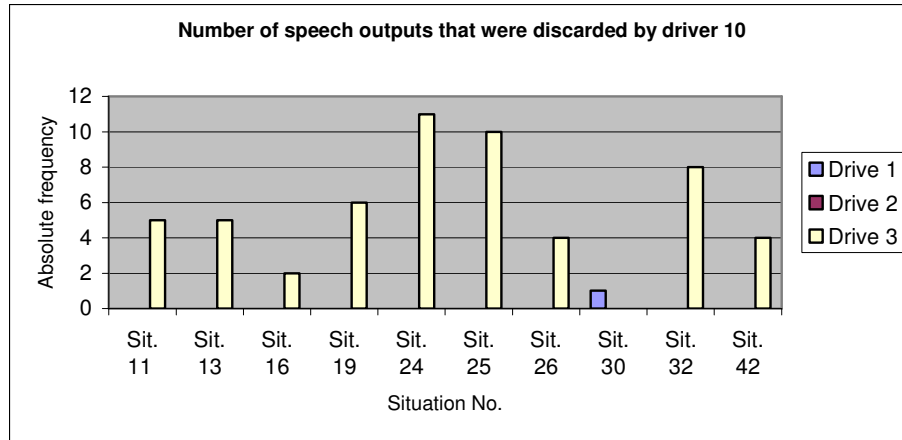

Figure 36. Number of times speech outputs were heard before being discarded for each driver in each drive

The graphs show differences between drivers in the absolute number of times they heard the outputs before discarding them as well as differences between drivers in the time until outputs were discarded (drive number). Based upon the type and timing of discarded feedback, drivers 5 and 7 show the clearest trend towards progressive learning. Assuming that participants discarded feedback when it was fully assimilated, interactions with the tutor system show a progression from the assimilation of declarative to procedural knowledge. Within each drive, participants actively switched off pieces of information regarding to different help categories. In the first drive, the discarded information was mostly related to system functionality. In the second drive, they tended towards discarding learnt operational usage of the system. In the last drive, participants had repetitively experienced system limits and began to discard the speech outputs related to more implicit, procedural knowledge. This trend is, however, not observable for all drivers. Two out of six drivers almost only discarded information in the last drive. One driver did not discard any information at all while another had discarded most information regarding the system's functionality and operation by the second drive.

The overall trend can be demonstrated more clearly by considering the rate of percentage outputs discarded per help category. Figure 38 shows the percentage of the overall issued feedback outputs that were discarded for each driver per help-category. An analysis based on the total relative number of received outputs per driver until their point of discard. With regards to the help category "scope of application", it is important to note that the tutor system developed for the driving simulator consisted of only one speech output related to this category. Thus, the only values in this category were 0% and 100%.

What is, however, noteworthy is the uniform trend. The graph shows that participants discarded a larger percentage of speech outputs in the help category "functional principal"

than in any other category (the category “scope of application” will not, in this study, be further evaluated as only one speech output is not representative for this category). The smallest percentage of speech outputs discarded by the drivers was in the help category “system limits”. By the end of the experiment, drivers 7 and 10 had discarded approximately 70% of all information related to the system’s functional principle, 50% of all information related to the system’s operation and none of the feedback related to the system’s limits.

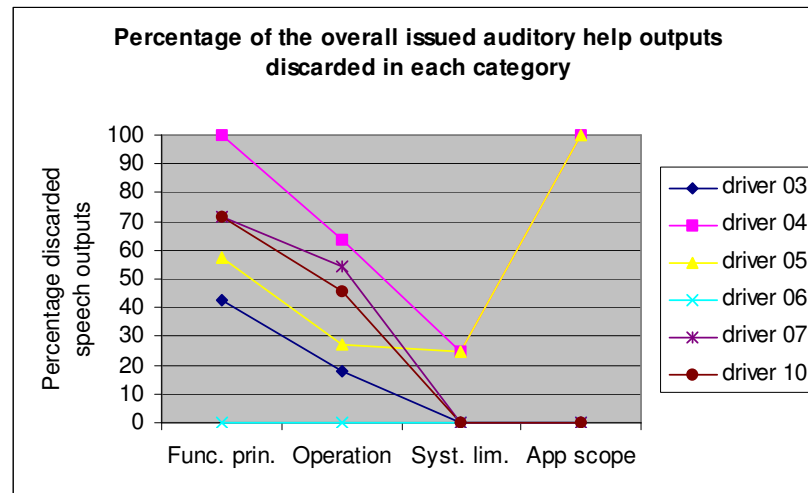

Figure 37. Percentage discarded acoustic feedback outputs issued to drivers

From the analysis, one might conclude that the information belonging to the category “system limits” is the most important to the driver and, therefore, that the speech outputs related to this category were in most cases never discarded. Another statement, as most of the participants listened to the information regarding the “operation of the system” longer than the speech outputs regarding the help category “functional principle”, might be that the functional principles of the system are quicker understood than the operation of the system. In any case, outputs regarding to the system’s functionality were turned off first, then advice and feedback related to operational usage and then to system limits, which led to believe that the system limits were seen as both very important and were also still, in part, not fully assimilated or understood. With regards to driver 6, as can be seen in the graph and as stated at the end of the experiment, the driver did not discard any of the issued information as he found them interesting and very helpful.

6.1.3.2 Acceptance of the tutor system

In Figure 38, drivers trust in the ACC system is compared between both groups. Participants were asked to rate on a scale from 1 (absolute trust) to 7 (absolutely no trust), how much trust they had in the ACC system. Both curves are surprisingly similar, with trust levels drive being similar in the first and in the last experimental drive. After the second drive, both

experimental groups show a drop in their level of trust in the system. This could be explained by the higher rate in the second drive of previously un-experienced ‘category A’ system limits (see Table 7). One of the reasons, as uncovered by the subjective questionnaires, was that, at first, participants were on the whole more trusting of the system than it can actually warrant. In the second drive, through the experience of more system’s limits, drivers trust receded. Finally, after the third drive, participants regain trust in the system. In the final drive, drivers’ mean trust ratings in the tutor condition fall below 2. At this time drivers are familiar with the system’s functionality, learned the operation and appropriate use and presumably, have also learned to predict the system’s limits more accurately. An independent samples t-test revealed a significant difference ($t = 2,95$, $df = 31$, $p = .01$, one-tailed) between conditions on drivers’ trust in the system.

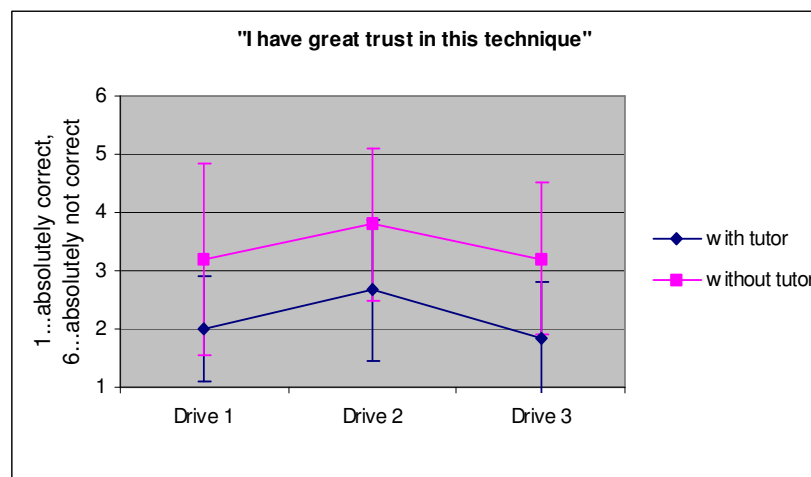

Figure 38. Drivers level of trust in the ACC system

A more noticeable difference in the comparison of the curves lies in the actual driver ratings. The participants who learned to use the system with the help of the tutor system, rated their trust in the assistance system one grade better on average. Whilst ratings ranged around a scale of three for the control group, trust ratings ranged around two for the control group. By this comparison, one might conclude that drivers learning the ACC-system with the aid of the tutor system quickly gained more trust in the system.

Figure 39 and Figure 40 show participants’ acceptance of the system. Participants were asked to rate on a scale from 1 (very helpful) to 7 (not at all helpful), how helpful the ACC tutor system was and how meaningful they thought the help actually was. The results in figure 40 demonstrate different trends in the curves over time. While drivers 03 and 07 rated the tutor system as being very helpful in the first two drives, after the last drive, they expressed less of a need. Drivers 05 and 10 rated the tutor system as helpful to very helpful after all three drives. Driver 06 rated the tutor system as “only” helpful after the second drive but after the third drive found it very helpful.

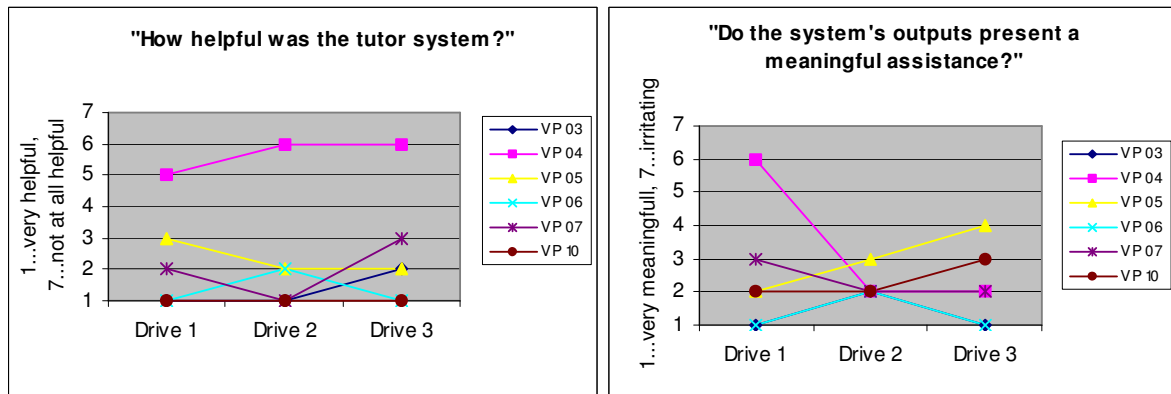

Figure 39. Drivers perception of the tutor's system helpfulness

Figure 40. Driver's perception of the meaningfulness of the tutor system's feedback

The exception, however, was driver 04 who rated the tutor system as being rather not helpful. A tentative explanation might be that this driver held a particularly high technical interest level and was also occupationally very well conditioned to such systems (being a pilot with a degree in aerospace engineering) conducting to a very easy and quick familiarisation with the ACC system. Although it is interesting to note that this test driver nonetheless rated the tutor system as being very helpful in the learning phase, as shown in Figure 41, and also that the system's outputs (after drive 2 and 3) were a meaningful aid (Figure 40). Figure 34 was only administered once to drivers, after the last experimental drive.

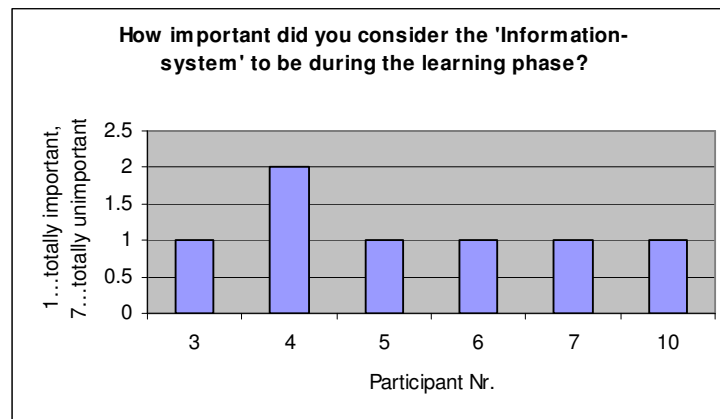

Figure 41. Drivers perceived importance of the system during the learning phase

Overall, drivers considered the tutor system as being a helpful or 'very helpful' (with one exception) assistance despite the level of drivers technical ability and preferred learning strategies. The tutor system was perceived by all as being very valuable in the learning phase. Further, 66% of drivers found the tutor system to provide meaningful or 'very meaningful' assistance (as opposed to being irritating) throughout all drives.

The trend towards reduced subjective ratings of meaningfulness at the end compared to the beginning of the drive, as demonstrated by drivers 05 and 10 in Figure 40, was expected and can be explained through drivers' learning progress. Indeed, the differences in drivers ratings over time can be attributed to the drivers confrontation to new system limits and the drivers 'compiling of the learned knowledge' in the second drive and to the preceduralisation of actions for which no additional feedback of the system is needed in the third drive. In this way, drivers relative perceived helpfulness over time can be explained. One might assume, for example, that the feedback and explanations received from the tutor system in drive 3, had already been heard numerous times by the drivers and eventually assimilated and understood. The drivers would then proceed to discard these outputs and then expectedly protocol that the tutor system was not as helpful at the end of the experiment, compared to drive 2.

Drivers acceptance was also measured in the degree to which drivers perceived the tutor system to increase traffic safety. The group that drove without the tutor system rated the visual display feedback from the standard ACC HMI whilst drivers in the tutor group rated the visual as well as acoustic feedback. Figure 42 shows the average rating for each experimental group. The comparison of both groups showed more positive ratings in the tutor group, with the difference between the ratings in each group increasing over time, starting in the first drive, with one scale difference. The curves both show a similar pattern to that of drivers trust ratings. An independent samples t-test revealed a significant difference ($t = 2,63$, $df = 31$, $p = .01$, one-tailed) between conditions on drivers' perceived feeling that the tutor system helped increase traffic safety.

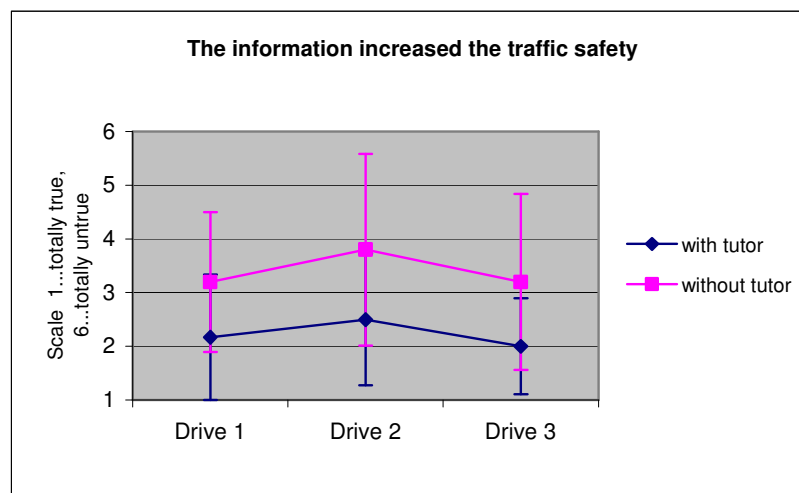

Figure 42. Effects of the tutor system on drivers' perceptions of traffic safety

6.1.3.3 Efficiency of the tutor system

The efficiency of the tutor system was measured by drivers objective interaction and perceived efficiency in the usage of the ACC system compared to the control group. The perceived efficiency of the tutor system was measured by drivers subjective feelings of their understanding of the system's behaviour over time as well as their subjective ability to predict when they needed to take over control of the system. The objective evaluation of the tutor system's efficiency consisted of the analysis of participants' driving behaviour and operational interaction with the ACC system. Driving behaviour was analysed using the measured data to derive appropriate driving parameters to compare behavioural measures for accelerated learning, sustained learning and safer driving behaviour in both groups. Further, the objective evaluation of the tutor system's efficiency was measured by a small administered test at the end of the study to compare participants held explicit knowledge of the ACC system. Participants' operational use of the system was determined by analysing the use of ACC controls as well as the brake and accelerator pedals.

In the subjective analysis, participants were asked, after each drive, to rate their understanding of the ACC-system. Drivers were asked how often they had the feeling during usage of the ACC-system, not to understand what the system was doing or what had just happened. The rating scale ranged from 1 (very rarely) to 7 (very often). Figure 43 shows the results averaged over all participants in both experimental groups.

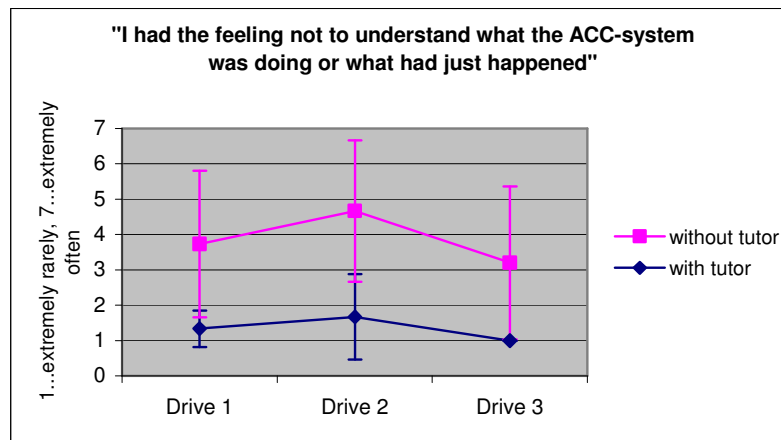

Figure 43. Drivers perceived understanding of the system

The comparison of both experimental groups presents noticeable differences. Although both curves show a similar pattern, from drive 1 onwards, participants in the tutor system group seem to have understood what the system was doing and how it was operating, while drivers in the control group were, from the beginning onwards, seemingly more unsure about the way in which the system was operating. The increased feeling of incomprehensibility in both

experimental groups during drive 2 can be explained by the fact that drivers experienced more unexpected system limits in which the system did not react the way the drivers had expected it to. By the end of the third drive, however, those in the tutor system group were unanimous of their clear understanding of the system's functioning and limits, while the drivers in the control group more or less stagnate at the same level as they began with. An independent samples t-test revealed a significant difference ($t = 2,39$, $df = 31$, $p = .01$, one-tailed) between the experimental groups on their perceived understanding of the ACC-system over all three drives.

Take-over situations typically occur when the system limits are reached, often demanding an active intervention from the driver. Figure 44 shows participants understanding over time of when situations required active driver take-over. Again, the comparison between both experimental groups presents noticeable differences. Whereas the participants that drove with the help of the tutor system had a good understanding of when they had to take over after the first drive, the drivers in the control group—with a difference of two scale points—had comparatively little understanding of when an intervention was necessary. Over time however, although a relatively steady learning process follows, the control group still does not reach a comparable level of understanding as the tutor group. An independent samples t-test revealed a significant difference ($t = 3,19$, $df = 31$, $p = .01$, one-tailed) between conditions in subjects understanding of when active intervention was necessary.

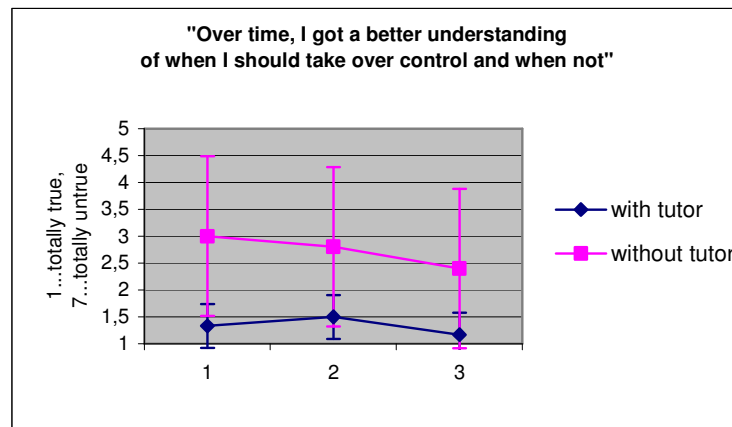

Figure 44. Drivers understanding of the need for intervention

The results of objective analysis of the system's efficiency are now presented. The analysis is threefold. Firstly, drivers reactions and behaviour in system limits are analysed; secondly, the participants operational use of the system and thirdly, participants' explicit knowledge at the end of the last drive.

'Panic' or hard braking

Situations where the limits of the system are reached often demand a driver response in what is often within a very limited timeframe. Thus, if the system limit was not predicted in time before it's occurrence, it is very likely that the driver will apply the brakes (with a reasonably high force) in order to avoid deviating from the middle of the road or possibly even to avoid a collision. Here, as in the analysis of the take-over situations in the long-term study, the absolute number of hard or 'panic' braking situations was analysed. Hard or 'panic' braking situations were defined as brake force measurements in excess of -6 m/s^2 .

Figure 45 shows the mean frequency of events in both conditions over all three drives. Considerably less variance and, overall, a considerably lower rate of panic braking in all three drives was observable in the tutor group.

There was a statistically significant main effect of condition (with tutor, without tutor), $F(1, 27) = 4,85$, $p = .03$, with drivers in the tutor condition exhibiting less 'panic' braking reactions. For many drivers, regardless of the experimental group, a similar trend is observable over all three drives with a reduction of panic braking after the third drive. The trend towards an increased rate of hard braking during drive 2 can be explained by the occurrence of system limits, which drivers had not yet assimilated. There was a significant main effect of the drive number on the hard or 'panic' braking, $F(2, 27) = 4,66$, $p = .01$. There was no significant interaction between the conditions and drives, $F(2, 27) = 0,11$, $p = .89$.

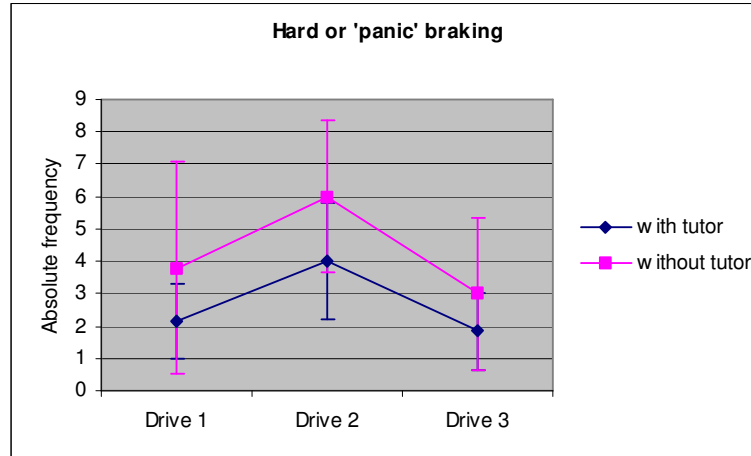

Figure 45. Frequency of panic braking per drive, averaged for both experimental groups

System disabled by speeds below 30 km/h

Deceleration rates was also used to measure the drivers' reactions to the automatic switching off of the system when it reaches speeds of 30 km/h or less. In these situations, the system will de-activate automatically and the car will effectively 'roll' on further uninfluenced by the ACC system. During initial usage, the driver might falsely presume that, in this situation, the system will effectuate a complete stop (or at least effectuate the deceleration necessary to prevent a collision with the lead vehicle). A high rate of 'panic braking' would indicate that

the driver has not yet understood the ACC system's limit, thus causing his or her surprise reaction. This particular system limit is one which belongs to the category of 'situations in which the driver must always intervene', representing a situation of relative clarity that requires initial learning but remains constant thereafter, requiring no need for further evaluation. Similar to this situation, is the situation of a standing vehicle. Standing vehicles cannot be detected by the system, thus also represent a situation in which the driver must learn that active intervention is always necessary. The latter situation, which occurs reasonably often on the road, is a potential source of danger at the beginning, if the driver does not know the capabilities of the system or has built a faulty or misconceived mental model of the system. Thus, for this purpose, the so-called 'very slow moving vehicle' situation was conceived. This situation was planned before a junction in which the lead vehicle slowed down to a full stop before turning right. As vehicles at standstill go undetected by the system, the idea behind implementing this situation was to warn the driver, driving behind a vehicle that had decelerated to 5 km/h from a speed of at least 30 km/h and predictably about to stop, that the ACC system does not detect vehicles at standstill. During this situation, however, a deceleration above -6 m/s^2 was not recorded in the experiment.

Figure 46 shows the absolute number of times the lead vehicle decelerated below 30 km/h in follow-mode in each condition for two drives (the first experimental drive was a strictly motorway drive in which the situation did not occur). These situations consisted of an approach to a junction or crossings in which the lead vehicle either came to a complete stop or slowed down below 30 km/h before driving on. On average, each driver experienced the situation 4 times. Figure 47 shows the number of times, for each condition, drivers exerted a hard or 'panic' braking force in this situation. Hard or 'panic' braking was defined as brake force measurements in excess of -6 m/s^2 . Figure 47 shows a tendency for more panic braking situations in the control group compared to the tutor group.

There was a statistically significant main effect of condition (with tutor, without tutor), $F(1, 18) = 4.03, p = .06$, with drivers in the tutor condition experiencing a reduced number of hard or 'panic' braking events during deceleration of the lead car to a speed below 30 km/h. An interesting trend that is observable in both conditions is the increase in the number of 'panic' braking events in the last drive. In the control condition, the trend is attributable to the fact that in the second drive (the first time the event occurred), drivers saw the lead vehicle decelerating and often applied the brakes cautiously before the speed fell below 30 km/h. In the last drive, however, drivers let the system take over the deceleration without intervening, which often caused, at slow speeds, a surprise effect resulting in a high braking force. The negative aftereffects associated to this experience are reflected in the participants trust ratings (Figure 38). There was no significant main effect of the drive number on hard or 'panic'

braking, $F(1, 18) = 1,07, p = .31$. There was no significant interaction between condition and drives, $F(1, 18) = 0,18, p = .67$.

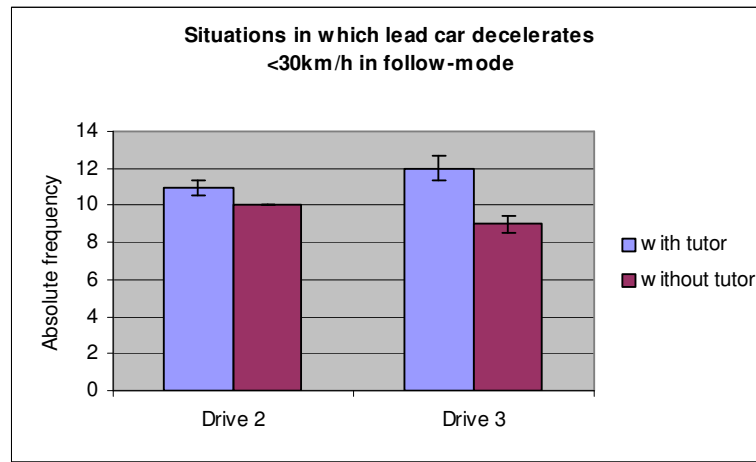

Figure 46. Absolute number of situations in which the lead vehicle decelerated below a speed of 30km/h

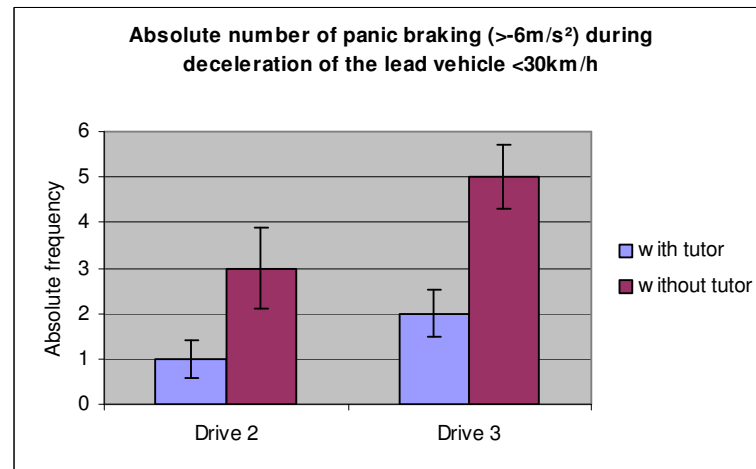

Figure 47. Absolute number of panic braking during a deceleration of the lead vehicle below a speed of 30km/h

The analysis of drivers' intervention and reactions to situations that require more learning with experience are now presented. The following situations require active decision making by the driver as they represent situations in which the ACC system limits can be reached, thus only sometimes require driver intervention (see Table 7).

Curve situations

Two types of curve situations were analysed: in a semi-critical situation, the curve radius was so sharp that the preceding car could no longer be detected and actually came out of the sensor range. In a non-critical situation, the lead car did not come out of the radar range in the curve, thus the ACC system could keep regulating the speed and the distance to it. In the latter

situation, an advice was issued, that in a tighter curve, the preceding vehicle might come out of the radar range and go undetected. In the semi-critical situation, drivers were issued a warning that the lead vehicle is no longer detected due to the sharp bend. The feedback emitted from the abovementioned situations thus differ not in the sense of the necessity of driver intervention but in the nature of the situation. In this case, a warning in the actual situation or an advice of what could happen in this type of situation. Upon drivers' intervention, the reactive tutor gave feedback to reinforce the driver's action or to remind him or her of the ACC system's capabilities.

The analysis of both types of situations, however, showed that no intervention was actually necessary in order to stay on the road or avoid a collision. The situation in which the curve radius was so tight that the ACC system had time to accelerate up to the preceding vehicle did not occur during the experiment. Similarly, situations in which a vehicle was detected too late in the curve did not occur during the experiment. Table 17 shows the total number of 'semi-critical' and 'non-critical' situations experienced by each participant. Both groups were exhibited to the same number of situations, one additional 'non critical' curve situation was planned for drive 1, however it rarely occurred as drivers applied the brake before the motorway exit (de-activating the system) in which a follow-mode in the curve situation was planned. It was thus omitted from the analysis. In drive 2, three 'non-critical' and one 'semi-critical' curve situation was planned whilst in drive 3, two 'non-critical' and two 'semi-critical' situations were planned. Participants in the control group experienced 10 non-critical and 7 semi-critical situations in drives 2 and 3 respectively. Participants in the tutor group experienced 12 non-critical and 8 semi-critical situations in drives 2 and 3 respectively.

Table 17. *Absolute number of curve situations experienced per participant*

	Non-critical situation in curve	Semi-critical situation in curve
Drive 2	2	1
Drive 3	2	2

Figure 48 shows that the tutor group made less unnecessary interventions in curves—both in situations when the preceding car comes out of the radar field and not.

There was a statistically significant main effect of condition, $F(1, 27) = 6,88, p = .01$, with drivers in the tutor system showing a reduced number of unnecessary interventions. In the non-critical situations, drivers in the control group had a comparatively high unnecessary intervention rate in drive 2, whilst no interventions in curves were made by either groups in drive 3. In the more critical situations, drivers in both groups applied the brakes in foresight during drive 2. In drive 3, drivers in the control group held a higher intervention rate. Overall, drivers in the tutor group made very few interventions, comparatively displaying more trust in

the system (see Figure 38) and demonstrating a better understanding of the situations requiring driver intervention. There was no significant main effect of the drive number on the number of interventions in curves, $F(2, 27) = 0,98, p = .38$. There was no significant interaction between condition and drive, $F(2, 27) = 2,26, p = .12$.

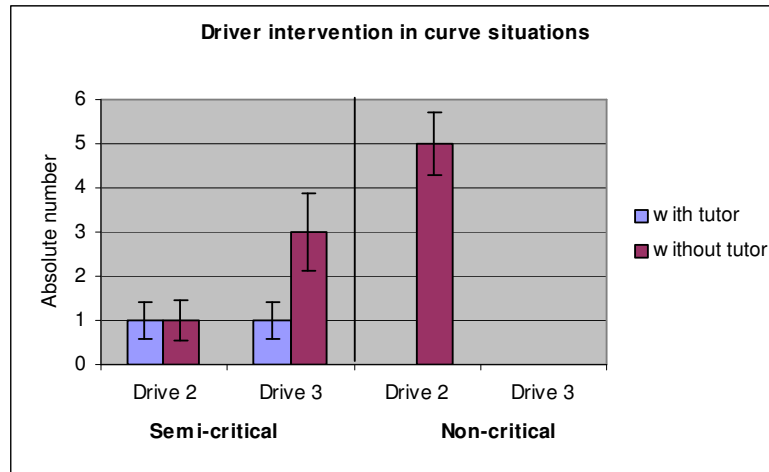

Figure 48. Absolute number of driver intervention in critical and non-critical curves for both experimental groups in each drive

Approach situations

In the following analysis, participants' interventions were analysed during 'approach to a lead vehicle' situations. Approach situations are situations in which the own and the lead vehicle drive with a constant speed difference towards one another. The analysis differentiates between high relative velocity approach situations in which driver intervention was required and situations in which the ACC-system's capacity was not exceeded, thus not requiring any driver intervention. In real-time, during the actual situation, the tutor system advised drivers that the ACC might not be able to compensate for the difference in speed. Upon intervention, the tutor issued a reinforcing feedback in the former situation or, in the latter situation, informed the driver that the ACC could have managed the situation.

The analysis of drivers' interventions was adapted to the signal detection theory, where the four possible outcomes are based on the combination of two states of the world (necessity to intervene or not) and two response categories (intervention or no intervention). Drivers' interventions were analysed in terms of the four classes of joint events: hits, misses, false alarms and correct rejections. The four outcomes are represented in Table 18.

Table 18. *The four outcomes of signal detection theory*

	Need for intervention	No need for intervention

Driver intervention	Hit	False alarm
No driver intervention	Miss	Correct rejection

Both groups were exhibited to the same number of situations. Table 19 shows the number of approach situations experienced by each participant in each drive. Per drive, participants experienced 10 and 12 situations requiring intervention and 20 and 24 that did not, in the control group and in the tutor group respectively.

Table 19. *Absolute number of approach situations experienced per participant*

	Approach requiring driver intervention	Approach which ACC could manage
Drive 1	2	4
Drive 2	2	4
Drive 3	2	4

Figure 49, 50 and 51 show the driver intervention categories, adapted from the Signal Detection Theory for approach situations in drive 1, 2 and 3 respectively.

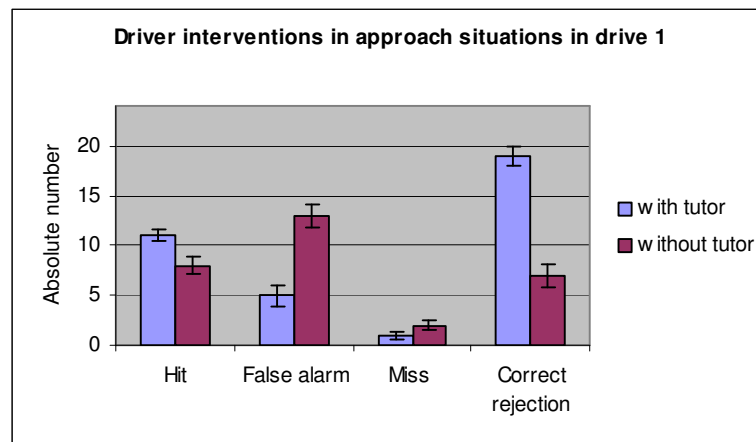

Figure 49. Absolute number of interventions during approach situations in drive 1

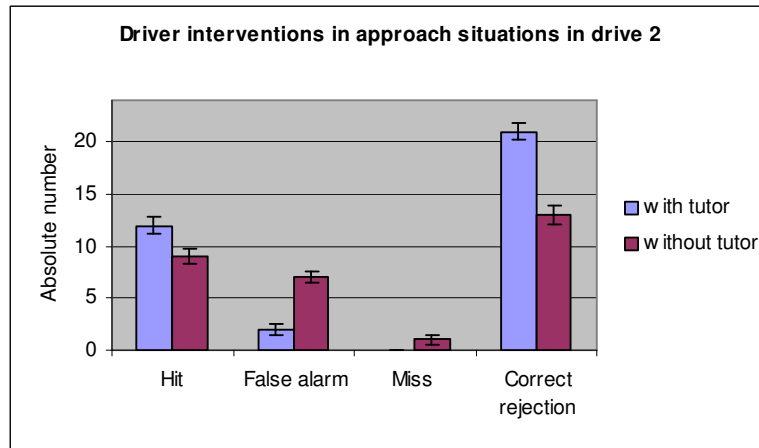

Figure 50. Absolute number of interventions during approach situations in drive 2

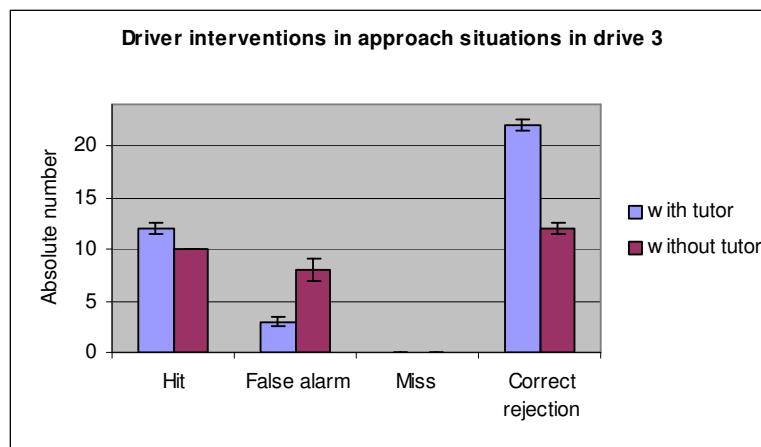

Figure 51. Absolute number of interventions during approach situations in drive 3

In both experimental conditions, a similar trend overtime is observable. At the beginning of the experiment (drive 1), a relatively high number of unnecessary interventions (false alarms) is observable. This might be explained by the fact that at this stage, drivers' confidence and trust levels are still developing. In the second experimental drive, a reduction of unnecessary interventions is already noticeable as drivers learn to predict the system capabilities. In the third drive, the number of unnecessary interventions increases. This may be explained by the fact that although very few system limits and critical situations were introduced, drivers still in an assimilation stage had an inaccurate or incomplete mental model of the system. Further, although some drivers had 'tested' the system limits in the first and second drives, some drivers were still testing the system limits and had not yet reached the proceduralisation of response actions to this type of situation. The number of hits, increased proportionally to the changes in the number of false alarms. The number of correct rejections remained steady, drivers did not seem to experience any difficulties with the ACC system during approach situations with low relative speed differences.

Four collisions occurred. All three collisions in the control group happened due to a late braking intervention in critical situations. The collision in the tutor group happened as the driver waited too long to see if the ACC system could manage, after he had heard the tutor's advice: "...ACC might not be able to compensate for the high difference in speed".

Despite similar trends over time within both groups, the figures show a difference between both experimental conditions in the number of unnecessary interventions. The difference between both groups is most marked in the first and second drives.

There was a statistically significant main effect of condition (with tutor, without tutor), with drivers in the tutor condition having a lower rate of false alarm, $F(1, 27) = 5,47, p = .02$. Similarly, the main effect of the tutor system on the number of correct rejections was significant, with drivers in the tutor group having a higher rate of correct rejections, $F(1, 27) = 10,96, p = .01$. There was no significant main effect of the drive number on the number of false alarms, $F(2, 18) = 0,65, p = .53$, misses, $F(1, 27) = 1,62, p = .213$ or in the number of hits, $F(1, 27) = 0,20, p = .65$.

Braking lead vehicle situations

As opposed to the approach to a slower lead vehicle situation, "braking lead vehicle situations" are follow-mode situations in which the lead vehicle suddenly applied the brakes. This situation may be particularly problematic during high decelerations of the lead vehicle, in excess of the ACC braking capability, and in very sudden decelerations in which case a timely activation of the brake by the ACC system may not be possible. The analysis differentiates between a high level of deceleration in which driver intervention was required and situations in which the ACC-system's capacity was not exceeded, thus not requiring any driver intervention. During the actual situation, the tutor system advised drivers that the lead vehicle is braking hard and that ACC might not be able to compensate for the high deceleration. Upon intervention, the tutor issued a reinforcing feedback in the former situation or, in the latter situation, informed the driver that the ACC could have managed the situation. As in the approach situation, the analysis of drivers' interventions was adapted to the signal detection theory (see Table 18). Drivers' interventions were analysed in terms of the four classes of joint events: hits, misses, false alarms and correct rejections.

Both groups were exhibited to the same number of situations, one additional 'braking lead vehicle situations requiring driver intervention' was planned for drive 2, however it rarely occurred as drivers were often slower than the lead vehicle in accelerating after the first junction which resulted in them not yet being in follow-mode when the lead vehicle applied the brakes. This situation was thus omitted from the analysis. Table 20 shows the number of approach situations experienced by each participant in each drive. In drive 1, participants experienced 10 and 12 situations requiring intervention and 15 and 18 that did not, in the control group and in the tutor group respectively. In drives 2 and 3, participants experienced 5

and 6 situations requiring intervention and 15 and 18 that did not, in the control group and in the tutor group respectively.

Table 20. *Absolute number of braking lead vehicle situations experienced per participant*

	Braking lead vehicle situations requiring driver intervention	Braking lead vehicle situations which ACC could manage
Drive 1	2	3
Drive 2	1	3
Drive 3	1	3

Figure 52, 53 and 54 show the driver intervention categories, adapted from the Signal Detection Theory for braking lead vehicle situations in drive 1, 2 and 3 respectively.

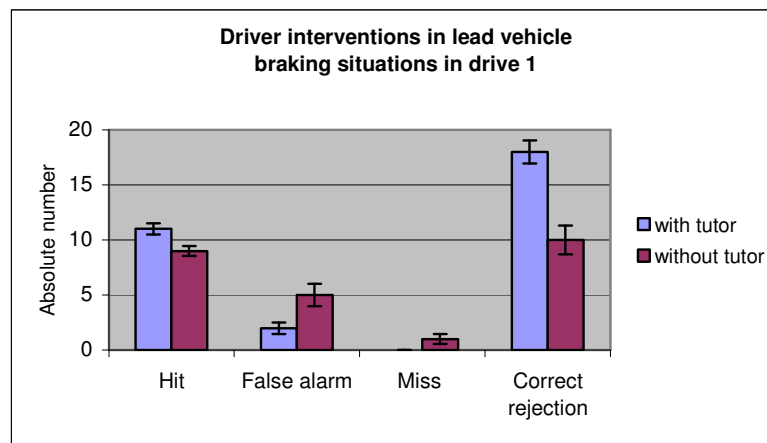

Figure 52. Number of interventions during 'lead vehicle braking' situations in drive 3

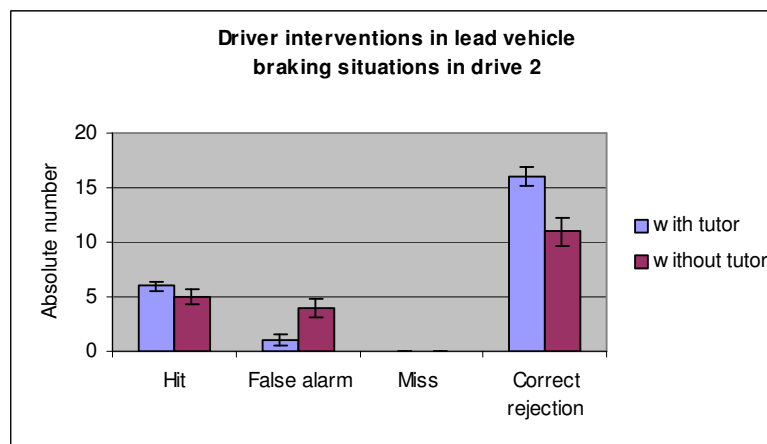

Figure 53. Number of interventions during 'lead vehicle braking' situations in drive 2

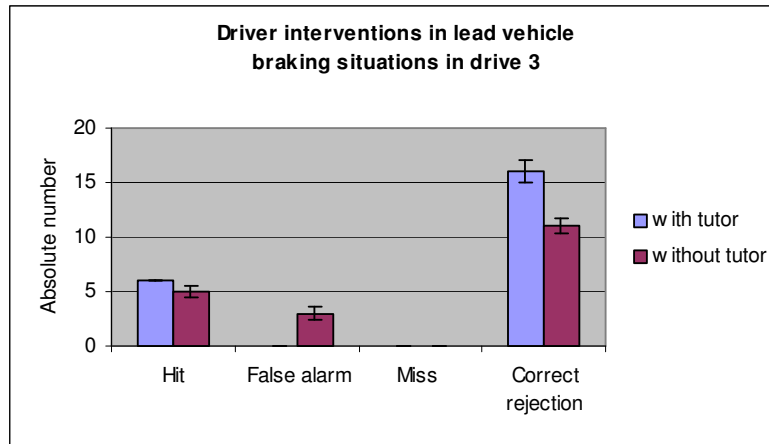

Figure 54. Number of interventions during ‘lead vehicle braking’ situations in drive 3

Again, the comparison between the experimental groups in the rate of unnecessary driver interventions in this situation showed a positive tendency for the tutor group. Overall, a markedly lower rate of unnecessary driver interventions was observed in the tutor group in situations where the lead car applied the brakes.

There was a statistically significant main effect of condition, $F(1, 27) = 6,91, p = .01$, with drivers in the tutor group showing a comparatively lower rate of false alarms. There was no significant main effect of the drive number on the number of hits, $F(1, 27) = 1,06, p = .31$, misses $F(1, 27) = 1,22, p = .27$ or correct rejections, $F(1, 27) = 2,30, p = .14$.

Use of the system in particular environmental conditions

Drivers use of the ACC-system with respect to safety in particular environments and environmental conditions was tested in poor visibility. Figure 55 depicts participants usage of the ACC system in fog. It was expected that drivers turned the system off in foggy conditions as the instructions explicitly mentioned that only the driver can warrant an effective monitoring in this condition.

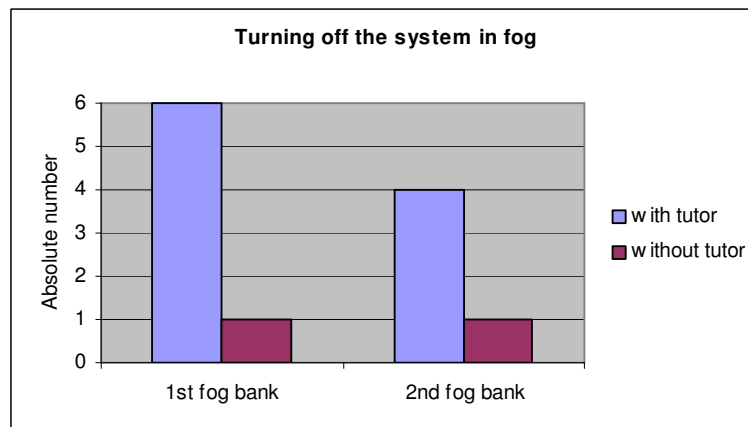

Figure 55. Usage of the system in adverse conditions (i.e. fog)

Participants in the tutor group turned the ACC system off on the first run, whereas only one in five turned it off in the control group. In the second fog bank, the situation in the control group did not change but two drivers out of six in the tutor group turned left the system on. This tendency can be explained by the driver's explanations. One driver reported that he wanted to try everything out and knew that in the simulator environment nothing would happen. While the other driver, demonstrating an insightful understanding of the system and source of potential misuse, explained that no system could be more ideally suited to foggy conditions. Overall, drivers in the tutor group turned the system off 83% of the time in foggy conditions compared to 20% of those in the control group. Drivers' speed at which they drove through the fog was also analysed. The average ACC speed driven through the fog in both groups showed that when ACC was not switched off, the average speed was 80 km/h ($SD = 14$ km/h) in the tutor group whereas, participants in the control group drove slightly faster, averaging speeds of 85 km/h ($SD = 17$ km/h) in the first fog bank and 94km/h ($SD = 17$ km/h) in the second.

Operational errors

In terms of operational errors committed by the drivers, two different error types were defined and analysed. The first type of mistake is attempting to use the system in a de-activated state. Drivers must understand the different activation modes of the system. The first time the 'on/off' button is pressed, the system will switch on. Upon the second time the button is pressed, the system will be activated. De-activation of the system by applying the brakes means that the system will have to be re-activated with either one press of the on/off button, which resets the last selected desired speed before the system had been de-activated ('resume button'), or by selecting the new, actual speed with the '+' or '-' buttons. Switching the motor off means the on/off will need to be pressed twice for the system to be active.

Within this context, an operational error can occur when drivers cannot remember how to activate the system once it has been turned on or when drivers cannot remember how to switch the system on. Occurrences of such operational difficulty can be measured by the number of times another button was pressed before the on/off button was selected, in which case drivers would be issued information on how the system can be turned on. In order to improve drivers mode awareness, feedback was issued to drivers if, when and how the system had been de-activated and also would confirm the system's re-activation. The second type of operational error, is the incorrect or ineffective use of the resume function (the setting of the last set desired speed). This situation occurs when a discrepancy above 50 km/h exists between the last selected desired speed and the actual desired speed. This was measured by five (or more) consecutive presses of the '+' or '-' button immediately or soon after the resume button had been used to select a new desired speed.

Figure 56 shows the absolute number of operational errors committed for all drivers per experimental group. It shows that, on the one hand, a considerable number of ‘failed attempts’ were made in each experimental group to turn the system on as well as to activate it. On the other hand, it shows that very few ‘ineffective use of the resume button’-type errors were committed.

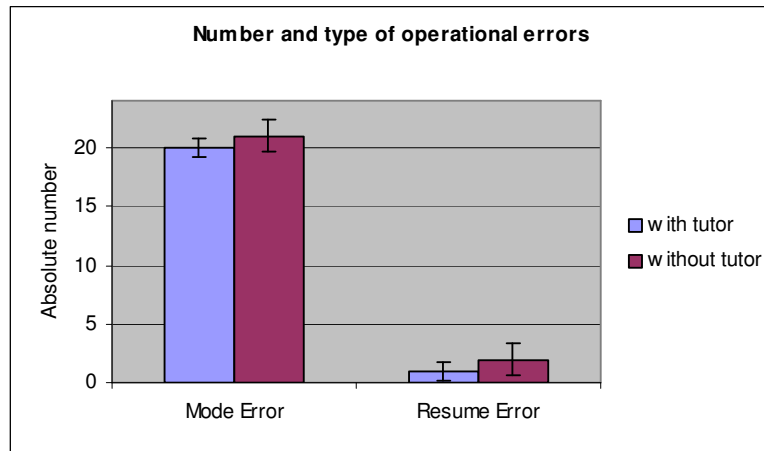

Figure 56. Absolute number of operational errors committed per experimental group

Figure 57 shows that overall, a trend towards a lower averaged percentage value could be observed in the number of operational errors in the tutor group. Nonetheless, both groups arriving at a similarly low percentage number of operational errors at the end of the experiment. The percentage number of operational errors for each experimental group was calculated by dividing the total number of operations related to switching the system on, activating the system and resuming the last set desired speed made by each group by the total number errors related to these procedures. There was no statistically significant main effect of condition (with tutor, without tutor) on the number of committed mode errors, $F(1, 27) = 0,79, p = .38$, or on the number of committed resume errors, $F(1, 27) = 0,20, p = .65$.

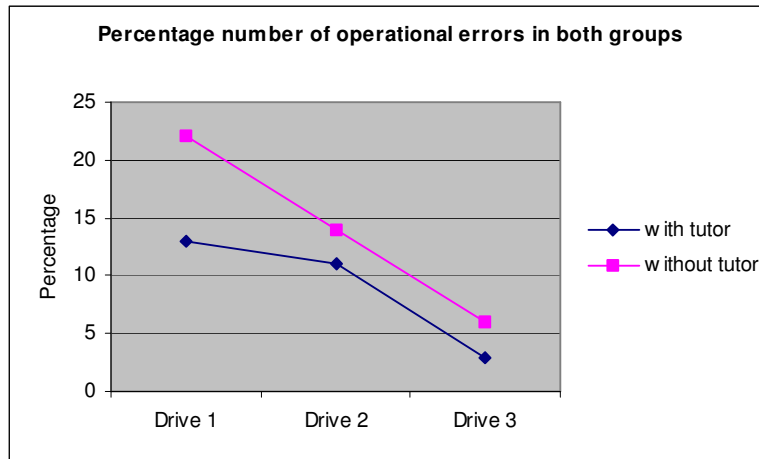

Figure 57. Percentage number of operational errors for each experimental group per drive

Driving performance

In terms of participants' driving performance, the total number of accidents were analysed. Only one type of accident was recorded throughout the experiment: crash into the lead vehicle. All accidents occurred while driving with ACC on, or just after the system had been de-activated by a driver's late intervention. In total, 8 crashes occurred over the entire experiment. Seven of these crashes took place in the standard group and one in the enhanced group. Table 21 shows the type of traffic situations at which these crashes occurred for both conditions.

Table 21. Total number of crashes in both groups over the entire experiment

Traffic situation	Number of accidents	
	Control group	Tutor group
Cut-in	1	0
Approach with >diff_v	3	1
Vehicle at standstill	2	0
Decelerating lead vehicle	1	0
Steep curve	0	0

Drivers explicit knowledge

A qualitative analysis of participants' understanding of the system consisted of a test, attributed at the end of the experiment, on drivers explicit knowledge of the ACC system. The questions consisted of very simple factual questions regarding the operation of the system and the system's limits. All the test questions are listed in Table 22.

Table 22. Test questions of the ACC system's operation and system limits

Question No.	Questions
1	What does the 'resume button' do?
2	How is the last desired set speed selected?
3	How can the actual speed be selected as the desired set speed?
4	How can the ACC system be turned off?
5	In what situation should the ACC system be turned off?
6	While using the ACC system, do you have to brake at a traffic light?
7	In what situation does the ACC system switch itself off automatically?
8	In what situation could the ACC system detect the wrong vehicle?
9	In what case would a vehicle not be detected by the ACC system?
10	Is the braking capacity of the ACC system limited?

Figure 58 shows the percentage number of drivers in both groups who correctly answered the questions. Results showed that drivers in the tutor group answered all the questions correctly, except for question 8, which one participant did not answer. In the control group, half of the questions were answered incorrectly by at least one driver. Only one correct answer was given to the question 5. Instead of citing environmental conditions such as fog, in which only the driver can warrant an appropriate monitoring, drivers in the control group answered that the system should be turned off at low speeds although at low speeds, ACC cannot, however, be used at low speeds, automatically turning itself off at a speed below 30 km/h. The control group also displayed some difficulties in answering easier questions related to the system's operation. For example, two drivers did not understand the purpose of the 'resume' function.

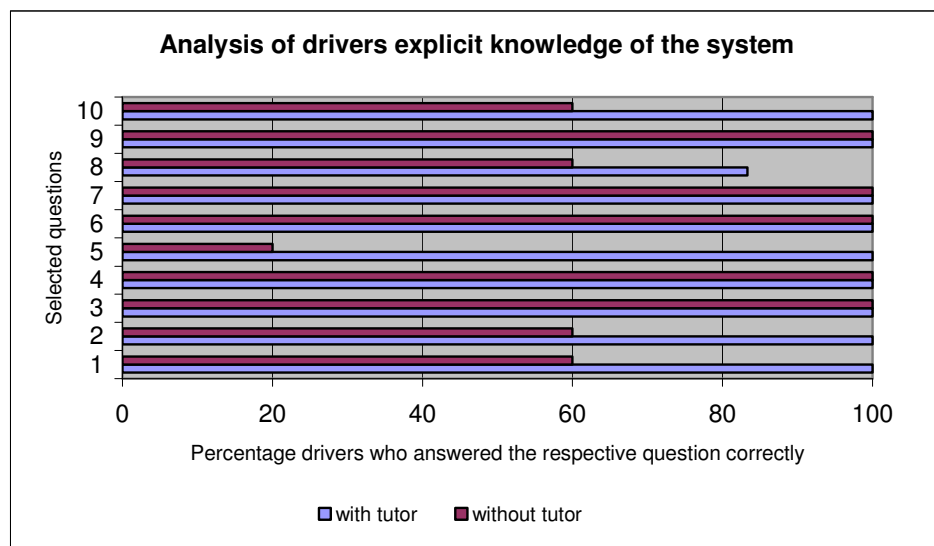

Figure 58. Drivers explicit knowledge of the ACC system

The analysis of drivers explicit knowledge of the ACC-system at the end of the experiment confirmed that drivers who learnt and experienced the system, with the aid of the tutor system had gained explicit knowledge of the system that was still missing in the control group. In total, 98,5% of the answers from the tutor group were correct compared to 75% of the answers from the control group. In conclusion, drivers answers show support for a quicker, increased learning rate with the help of the tutor system. The explicit knowledge drivers gained through feedback in the tutor condition, helped them build a more concise mental model that was closer to the real system image, which was reflected in a better ability to predict the system's behaviour and a safer driving behaviour.

6.1.4 Discussion

As presented in chapter 2, driver assistance systems potentially offer great advantages for drivers but as demonstrated in the long-term study on ACC usage, ADAS can be a source of confusion for the driver. In response to the increasing complexity of in-car features and the current trend towards the integration of driver assistance systems to the already existing panoply of features and telematic advancements. The learn-adaptive, multi-modal tutor system described in this paper is one solution, in a relatively novel field, towards improving drivers interaction and understanding of these systems. Through a situation detection module based on real sensor data, the tutor issued on-line situational and context specific advice in real time. The ACC tutor system was empirically evaluated in a driving simulator experiment.

Overall, the analysis results show a mixed tendency for the tutor system, not only in terms of actual usage but also in efficiency and overall acceptance. The usage of the system, analysed by the number and time at which feedback was discarded, demonstrated an individual use of the system. Participants subjective impressions of the helpfulness and meaningfulness of the tutor reflected the different trends in system use.

In the comparisons of subjective responses from the control and the tutor group, significant differences were found in drivers understanding of what the system was doing, in drivers trust in the ACC system and in drivers ability to predict when an intervention was needed in order to take over control of the system. In terms of an 'error free' efficient use of the ACC system, no significant differences were found between the experimental conditions in the operational usage of the system. Drivers in the tutor group, however, showed a significantly more effective use of the system, demonstrating significantly less unnecessary interventions in approach situations, curve situations and in follow-mode situations where the lead vehicle applied the brakes. The tutor system also seemed to have a positive effect on overall driving safety. Less lead vehicle crashes in the tutor system occurred and a significant difference between both groups in the occurrence of potentially dangerous driving situations due to drivers reactions i.e. panic braking, in unforeseen situations was shown.

Overall, the investigation of the long-term usage of ACC in the field successfully provided the in-depth information required to develop a system capable of improving the drivers' interactions with the system and accelerating the learning process by (1) responding to the difficulties met by users in the actual situation; (2) reducing possible negative consequences of users' reactions to the system; and (3) at the same time achieving the required compatibility with users' mental processes. The results are now discussed in terms of the formulated hypotheses of the theoretical concepts underlying the tutor system.

From the contextual, situated information available from participants' interaction with the system and the situation monitoring module, the first hypothesis predicted a safer due to a more appropriate use of the ACC system in less-than-optimum application scope, a reduced number of operational errors (mode errors and activation errors) and lower collision or near collision rates and panic braking reactions in the tutor group.

Contextual feedback related to the less-than-optimum application scope of the ACC system were incorporated in the help category "range of application". Although situations from this 'help category' include driving on different road types, in different traffic densities, within the short time frame, the situation that was tested concerned the use of the system in adverse weather conditions where visibility was reduced i.e. driving through a fog bank. It was expected that the system would be turned off in foggy conditions as the instructions handed to the participants explicitly mentioned that only the driver could warrant an effective monitoring in this condition. Surprisingly, however, the results showed that, overall, 20% turned the system off in the control group, whereas 83% of those who had received additional acoustic feedback regained manual control. Further, average speeds at which participants drove through the fog bank was higher in the control group. A trend therefore, that the tutor system helps to increase drivers' safety in this situation is demonstrated, however, more investigation would be needed in order to accept or reject the hypothesis that drivers with increased timely, situation-specific feedback drive more safely in particular environmental circumstances.

In terms of operational errors, two different error types were analysed: mode type errors and ineffective use of the resume function. Ineffective use of the resume function remained negligible in both groups. No significant difference was found between both groups in the number of 'mode' types of operational errors. Although, the tutor system showed a positive influence on drivers operational error rates as well as a better retention of the system operation over time, the hypothesis can not be accepted on the basis of these results alone.

Mode errors are typical of relatively automated performance or of high workload. Although both groups show a tendency towards making less errors over time, drivers in the tutor group start at a considerably lower level. Since both groups had a relatively low level of experience

with the system, it may be speculated that a higher attention demand on the task was put on the drivers' in the standard group. In terms of Reason's (Reason, 1992) error taxonomy, the tutor system was designed to also help reduce knowledge-based mistakes i.e. decision-making errors, in which correct plans of action are arrived at because of a failure to understand the situation. These types of errors are most likely to occur at the manoeuvring level, in take-over situations.

The first hypothesis concerned drivers' panic or 'surprise' reactions as the ACC system reaches its limits and an intervention becomes necessary. These situations, where the limits of the system are reached, often have a certain learning curve, as they demand a driver response in what is often a very limited timeframe. Thus, if the system limit was not predicted in time before its occurrence, it is very likely that the driver will apply the brakes (with a reasonably high force) in order to avoid deviating from the middle of the road or even a collision. Anchoring feedback to this type of situation and issuing early advice or warnings were thought to prevent this type of negative driver reaction. Within this context, it was hypothesised that drivers in the tutor group would show less panic braking in situations where the system limits are reached. The results of the analysis showed that overall, a lower rate of panic braking in all three drives was observable in the tutor group. A significant difference in driver's rate of 'panic braking' was found between drives of the control and the tutor groups.

A particular situation in which panic braking was instigated is when the ACC vehicle reaches a speed below 30 km/h. Although this situation does not belong to the more 'learn intensive' system limits, it represents, nonetheless, a situation in which an unprepared driver could be surprised as the need for intervention becomes necessary. Thus, a high rate of 'panic braking' indicates that drivers have not yet understood the ACC system's limit, causing a 'panic' reaction. The analysis of drivers rate of hard or panic braking (deceleration >-6 m/s²) after the ACC vehicle speed reached a speed below 30 km/h, presented considerably lower rates of panic braking situations in the tutor group. A significant difference was found between groups when the ACC automatically switches itself off at speeds below 30 km/h.

Thus, the hypothesis that drivers in the tutor group will be less surprised when the limits of the ACC system are reached, and therefore have less hard or 'panic' braking situations is accepted.

In terms of collisions, the only type of collision recorded was a crash into the lead vehicle. The number of accidents were too small for statistical analysis but this result, largely linked to situations in which the onset of panic braking was too late, shows further support for the hypothesis.

The second hypothesis predicted that drivers in the tutor group would have a better understanding and ability to predict when intervention was necessary due to the learning feedback and the reactive feedback on participants' actions issued by the embedded tutor.

The results showed support for the differences between the groups in drivers' perceived understanding and their ability to predict necessary interventions. Indeed the comparison of participants subjective understanding and ability to predict the need for intervention revealed a significant difference between both groups. Whereas drivers in the tutor group had a good understanding of when intervention was necessary, the drivers in the control group had comparatively little understanding of when an intervention was necessary. These results were further supported by objective driver behaviour measures.

Drivers' responses to particular traffic situations in which the ACC system limits could be reached showed a tendency for drivers in the tutor group to be prepared for such situations, as demonstrated by their ability to predict the situations in advance and by their appropriateness of active interventions. In approach situations, for example, a significant difference between both experimental groups in the number of unnecessary braking situations was observed. The analysis showed a very favourable trend in the tutor group, who made considerably less unnecessary interventions throughout the experiment. Similarly, in situations involving a sudden deceleration of the lead vehicle in follow-mode, the comparison between the experimental groups in the rate of unnecessary driver interventions showed a significant difference.

A further problematic situation while driving with ACC is driving in curves. Two types of situations in curves were analysed: the situation in which the lead vehicle remains within the ACC radar sensor range in a curve and situations in which the lead vehicle actually comes out of the detectable radar range due to the curve's sharp radius. The tutor group exhibited significantly less unnecessary interventions in curves compared to the control group (both in situations when the preceding car comes out of the radar field and not). In the non-critical situations, drivers in the control group had, comparatively, a very high unnecessary intervention rate in drive 2, whilst no interventions in curves were made by either group in drive 3. In the more critical situations, drivers in both groups tended to apply the brakes in foresight during drive 2. In drive 3, whereas drivers in the control group held a much higher intervention rate, drivers in the tutor system group intervened very few times, showing more trust in the system and demonstrating a good understanding of the situations requiring driver intervention.

Thus, from the analysis of both subjective and objective data, the hypothesis that drivers in the tutor group had a better understanding and ability to predict when intervention was necessary is accepted.

The type, amount and timing of feedback all seem to contribute to improve driver expectations and the predictability of situations, which play a major role in drivers' reactions to discrete events such as take-over situations (van der Hulst, 1999). Situating feedback helped drivers build a situational model whereas the learning feedforward of the system's operation and feedback of drivers' reactions during or proceeding take-over situations helped improved drivers' to predict the status of the system in the near future and actualised drivers' expectations. Despite research showing drivers with active control over the driving task are have better situation awareness (Gugerty, 1997), results show that appropriate feedback can bring drivers back into the control loop even within the adaptation process to the level of automation.

Paramount to the effectiveness of the tutor in decision making situations is the minimal delay between action and the knowledge of results (Anderson et al., 2001). The frequency of feedback, attributed during the situation or directly afterwards, repeated itself as many times as the situation occurred, for every situation, until it was discarded by the driver.

Evidence in the literature on drivers over-estimating their level of knowledge and skill (Groeger & Grande, 1996; Guerin, 1994) might lead to drivers' turning off the feedback and advice from the tutor module before they have really reached the goal of learning. The results showed, however, that drivers did not discard feedback before it had been assimilated.

Finally, the tutor system aimed to improve subjective understanding of the ACC system as well as increase driver's explicit knowledge of the system. It was hypothesised that by making knowledge of the system more explicit, drivers in the tutor group would gain a comprehensive understanding of the system's functionalities more quickly. Differences between groups would be observable from participants' stronger subjective feelings of trust, understanding and safety, as well as a more comprehensive knowledge of the system's scope of operation and limits.

Drivers in the control group were, from the beginning onwards, seemingly unsure about the way in which the system was operating. By the end of the third drive, drivers in the tutor group had learnt the system limits and were able to gain a clear understanding of the system's functioning, while the drivers in the control group more or less stagnated at the same level as they began with. A significant difference was found between groups on drivers perceived understanding of what the ACC-system was doing and how it was operating. Similarly, significant differences were found in participants' subjective feelings of trust and safety between both groups.

The analysis of drivers explicit knowledge of the ACC-system at the end of the experiment confirmed that drivers who learnt and experienced the system with the aid of the tutor system had formed a mental model of the system closer to the actual driver assistance model as those

in the control group. Results showed that, in total, 98,5% of the answers from the tutor group were correct compared to 75% of the answers from the control group.

Thus, the hypothesis that drivers who learned to use the ACC-system with the help of the tutor system and frequent explicit feedback in the learning phase formed a more concise, reality-near model of the system more quickly, was accepted.

Overall, the results of the analysis showed a positive influence of the integration of cognitive apprenticeship methods in vehicles. The core teaching methods –observation, coaching and practice– or what proponents of cognitive apprenticeship call modelling, coaching and fading, in which drivers receive feedback on their behaviour as well as the system’s behaviour within specific situations aids ‘apprentices’, through guided supported practice, towards expertise. The contextual variable in the learning process i.e. embedding the learning of skills and knowledge in their social and functional context by anchoring feedback to situations has shown to be a successful method to increase meaningful learning and even increase learner motivation as attention is sustained and relevance is maintained.

Learning-adapted feedback through intelligent tutoring further built up driver’s confidence by increasing their trust in the system, helping to reduce feelings of frustration or social incompetence sometimes associated to the use of a new system. Indeed, the feedback of the tutor system was very well accepted by drivers and valued in terms of comfort, safety, and above all, as an important aspect of the ACC system in terms of learning to operate the system and to understand and predict the system limits, particularly during the initial usage of the system.

The analysis of drivers behaviour during the use of advanced driver assistance systems like the ACC has demonstrated similarities in driver interactions with the system and behaviours over time. Despite individual trends in the learning process, a general pattern is observable that shows support for Anderson’s (1993) three learning stages.

Drivers firstly enter a highly cognitive first stage where explicit, declarative knowledge of the system is needed to understand the basic system functionalities, the way in which the system is operated as well as to grasp a theoretical representation of the system limits. This stage was demonstrated by the use made by drivers of the tutor system’s feedback. Over time, and especially in the testing phase, drivers build up a model of the way in which the system works and gain experience in setting secondary functions according to the appropriate situation i.e. selecting a distance on a country road. The experience gained will then lead to a higher level in which driver settings will be tested in combination with system limits which the driver has already experienced (conscious experimenting) or that have not yet been experienced. The strong associations of the system limits and learned reactions to these particular situations, or the application of the same declarative knowledge to different circumstances, result in

different rules or ‘productions’ being formed which support the different uses of the same knowledge.

The cognitive apprenticeship method of making knowledge as much as possible explicit knowledge created an implicit understanding of the system. The differences between the groups in the level of declarative feedback, led to a faster set of rules being built in the tutor group, whilst drivers in the control group needed more time to make associations regarding the system limits and the appropriate responses. In this study, drivers level of proceduralised behaviour, in which some or most of driver’s reactions are ‘automatic’, effortless and highly consistent, would need further research in order to be validated. The drivers behaviour at the end of the experiment could, for example, be tested against ACC experts’ behaviour.

The trends in the learning process of the long-term analysis of ACC driving in the field showed no significant difference between drivers, however, a significant difference was found between the drivers over the whole process. This progression through the stages might have been attributable to drivers individual levels of technical affinity, motivation or trust, however, for all cases, the analysis of drivers interaction behaviour has shown that drivers progress through the stages at different speeds but also that knowledge of the system is quantitatively different once a repertoire of ‘condition-action’ rules has been accumulated and formed compared to when drivers are still learning. In comparison, the results of the analysis of drivers learning to use the ACC system with and without the help of a learn-adaptive tutor presented significant differences between drivers of both groups although regardless of the experimental group, similar trends were observable over time. This similarity in trends demonstrated in many graphs between both groups over time often presented a gradual decrease in sub-optimal interaction with the system over time with a slight increase in the second drive. Although an improvement in driver’s behaviour was often demonstrated by the end of the third drive, the reason for the falling short of evidence for a full transition into proceduralised, automatic driver behaviour might be the relatively short interaction times participants had with the ACC system. The reason for the slight increase of sub-optimal driver reactions to system limits in the second dive is not attributable to regression in divers skills but a prolonged period of assimilation or ‘knowledge compilation’ as drivers are confronted with some previously inexperienced situations and new system limits. These trends in drivers’ interactions or ‘usage curve’ with the system show similarities to the learning process observed over the three first quarters in long-term system usage in the field and to the drivers surprise reactions upon discovery of system limits.

Overall, a more effective operation of the system (i.e. reduced operational errors), and a better understanding of the system was achieved by monitoring the driver’s effectiveness in interacting with the system, and adaptively advising the driver what to do when the observed

effectiveness is low. Thus, at the strategical level, users could use the knowledge from the system and quickly acquire a safer behaviour. At the operational level, situated feedback enabled a faster assimilation of the basic system operation and the acquisition of skill. At the tactical level, however, a micro-adaptation approach, adapting instruction in accordance to the driver's learning stage with a closed loop feedback control of the situation, did not always help drivers to progress from a rule-based to a skill-based behaviour. As previously mentioned, this may be due to the short interaction times drivers had with the system. An alternative explanation, however, may be that the experience drivers must make in order to learn the sensor and controller behaviour and limits cannot be theoretically acquired. Further, in these critical situations, where an immediate reaction of the driver is sometimes needed, spoken warnings may be too long. Listening and transforming the information into a motor response may take longer than the actual time needed for the required reaction. The interface should thus mediate the potential danger of these critical driving situations by an early, brief warning of the system's limit and a redundant information about the actual criticality (danger) of the situation.

Nonetheless, the feedback from the learn-adaptive, multi-modal tutor system increased the speed of the learning process, allowing drivers to move along the learning stages more quickly, towards the acquisition of skill.

As yet, the novelty of ADAS and the still relatively unknown extent of learning difficulties and human factors issues their introduction might lead to, has meant that there exists, to the authors knowledge, no similar situation-specific, learn-adaptive tutor system on the market (Kopf & Simon, 2003). Thus, the results could not be tested against any other system but only against the learning and efficiency rates of drivers who did not benefit from the system. Research into driver's need for the type of personalised, online information system presented here becomes more vital as new types of driver assistance are continuously being developed and will undoubtedly be brought onto the market in the not too distant future. Although the proposed solution may be the first in a long line of solutions to try and improve drivers understanding and acceptance of driver assistance systems, it highlighted the importance of frequent, explicit auditory feedback and presented a successful way of integrating it into the car to promote and accelerate learning towards effective and safer human-ADAS-environment interaction.

The significant carry-over effects in the conditions of the experiment eliminated the possibility for a related samples design. However, increasing the sample size or the testing time for each participants, might have reduced the variance between groups and increased the study's power. Nonetheless, effects of conditions on the drivers behaviour was clearly identified on many aspects of interaction. Although not always significant, the tendencies

observed presented a meaningful insight into the effect of the tutor system. In an attempt to rule out any systematic bias stemming from the differences between participants, it was made sure that they were equally distributed by randomly attributing drivers across conditions. Further, drivers were matched in terms of driving experience in the driving simulator and technical affinity. In terms of external validity, the tutor system would need to be implemented into a vehicle and tested with more participants, in real conditions.

If a similar system was to be implemented and tested in real traffic a number of improvements to the tutor system could be made. Firstly, especially in view of its implementation into a real car, the prioritisation of the emitted speech outputs would need to be reviewed in order to improve the timely and contextual factors towards increased learning with minimum intrusiveness. Secondly, driver workload should be taken account of by the sub-module of the tutor system, making sure that additional information about the drivers behaviour or of the system itself are appropriate in that moment, taking account of the driver activity and the in-car and external environments (Färber et al., 2001; König et al., 2000; Mayser et al., 2003; Young & Stanton, 1997). Thirdly, the tutor system HMI could be improved, the content of the speech outputs, for example, could be ameliorated in terms of the wording. The speech outputs could be more concise and the tone frequency, pitch, word debit, phonetic or other acoustic factors influencing their comprehension could be tuned. Further, the positioning of the info-button was too far down, forcing drivers to take their eyes off the road to locate it. A more appropriate location may have influenced the number of times drivers discarded feedback. Moreover, the implementation of a dialogue module enabling drivers to communicate with the system could be implemented for an online knowledge 'quiz' in the car or to answer driver questions on a specific topic. Finally, different feedback modes adapted to different learning types might be tested. As opposed to a situation specific, automatic emittance of feedback that can be discarded, drivers would be automatically informed in the situation, via the display, of the availability of information. Drivers could then press the info-button when they required additional help or advice. Drivers could decide for themselves, from the beginning onwards, whether they want to hear additional information concerning the ACC system. In other words, this mode would work like a pull mode (where drivers pull the required information from the system) as opposed to a push mode. When asked which mode drivers would prefer, approximately half of the drivers said they would probably prefer a pull mode. The different tutor modes were originally developed to accommodate differences in drivers learning styles. The pull mode was construed for 'active' drivers that typically have a high technical affinity and like learning new technical systems by trial and error. The push mode was construed for 'passive', more conservative drivers who feel more unsure when using new technical systems and would prefer to have someone there to give them

explanation, help and advice on its usage. The hypothesis that ‘active’ drivers prefer a pull mode is still to be tested.

The feedback from three help categories addressed five of the main learning aims of driving using ADAS outlined from the analysis of the long-term ACC study. The fourth category of feedback addressed drivers ability to predict the need for intervention and of integrating the system into normal driving style, the sixth and seventh learning aims. This study has demonstrated that by increasing the amount of feedback information a driver receives about his/ her own actions and the system’s operations, drivers achievement of the learning aims was accelerated. Explicit knowledge, particularly, of the system’s operation and functionality was quickly assimilated through feedback. In terms of higher levels of comfort through proceduralisation and the ultimate aim of improving driving safety through the use of ADAS, the fourth category of feedback, is of most importance. Drivers showed a tendency towards better predictability and understanding of the system. However, in these situations, where timing is the most crucial factor, drivers rates of unnecessary interventions were still relatively high, with disproportionate high braking or ‘panic braking’ rates and a proportionally high number of accidents or near-accidents.

In section 5.3, an alternative approach is presented. It is not system-based, improving the system through additional feedback and information but human-centred, based upon drivers internal references of risk and personal braking preferences. The original ACC warning algorithms were replaced and the exhaustive feedback of the tutor module was replaced for succinct information with improved timing of feedback through personalisation. The system focused on the learn intensive, safety critical ACC system limits. Through a multi-staged warning system, comfort warnings, specific to drivers internal risk taking reference and comfort subjectivity could be distinguished from safety alerts, in which a quick response is needed. The display would thus reduce the amount of decision-making in high demand situations, improve transparency in the system’s operation and help drivers’ integration of the system into their own driving style. This would result in more correct detections and correct rejections in critical situations, as well as more adequate braking interventions in take over situations. Besides increasing driving safety, it would increase drivers trust and perceived comfort and usefulness of the system. This system was implemented in the BMW driving simulator and empirically evaluated. The results are presented in the following section.

6.2 Driving Simulator – Personalised ACC multi-level warning system

6.2.1 Introduction

The aim of this study is to establish whether a simplified, personally adjusted display can improve the driver's ability to predict the need for intervention in critical situations. A critical situation is defined as a situation in which the system limits are reached and therefore require active driver intervention. As these events occur randomly and relatively seldom, drivers will find them, particularly during the learning phase, difficult to predict. In these critical situations therefore, the driver will exhibit a behaviour that is more or less risky. His/ her behaviour determines the latency time between the detection of a problem and the reaction i.e. the central cognitive process in the perception-decision-action cycle.

The inclination of the driver towards adopting 'risky behaviour' determines the internal reference that is adjusted to execute an action, which must lay within the safe reaction time, i.e. the time necessary to react and required to avoid a collision. The more risky the behaviour, the less time for a reaction is left and therefore the shorter the distance is to break to avoid a collision. As user of the system, one cannot be sure of the boundaries of those safe limits (comprising maximum allowable distance and minimum allowable distance), which people choose regarding their risk behaviour i.e. internal reference. The great challenge now is to find the internal reference people use during the use of the ACC system, i.e. decide on their risky behaviour while using the system.

Drivers' braking behaviour over a longer driving/ repeated system usage i.e. 2-3 weeks, showed how, over time, drivers learned to adjust their response criteria. In the first simulator study, it was hypothesised that the response criterion i.e. the assessment of critical situations necessary to build an internal reference on how to react in a critical situation, is dependent on learning, i.e. getting used to the system and becoming more comfortable with it's functioning over time, through timely and learn-adapted feedback. It is now hypothesised that the response criterion is not only dependent on learning, but can be influenced by targeted additional information about the systems' behaviour in the initial usage phase by providing more information to the user to help him/ her determine the adjustment of their internal reference. The main question to be addressed in this study is whether a two-step, personally adjusted alarm signal can improve the driver's ability to predict the need for intervention in take-over situations.

The objective was to develop an interface that most effectively supports the human interaction with Adaptive Cruise Control (ACC) systems in take-over situations. Recently, Kiefer et al.

(1999) investigated the effectiveness of a single-stage alarm arguing that the system should be kept simple unless one could find evidence that any additional complexity was beneficial. The rationale for a multi-stage collision warning display is that it could provide additional benefit because it is less constrained by the trade-off between alert intrusiveness and early warning.

A multi-stage warning, in comparison to a single-stage warning allows the warning system to provide an appropriate degree of intrusiveness at differing levels of urgency. In the maximally urgent situation of an impending collision, the alert must be sufficiently intrusive to immediately elicit an appropriate response from the driver. Because of the inherent correlation between intrusiveness and driver annoyance, the high degree of intrusiveness required by an imminent warning would render it inappropriate for less imminent situations. Constrained by a trade-off between intrusiveness and advanced warning, earlier timing for a single-stage display requires less intrusiveness (which is less likely to capture the driver's attention). An effective single-stage alert is therefore limited in how much advanced warning it can provide. The advantage of a multi-stage display is that it provides the opportunity for both advanced warning and a highly intrusive imminent alarm. A single-stage display must balance the intrusiveness of the alert stimulus with how early the alert is triggered. Providing the driver with an earlier warning, results in a display that will be triggered more frequently, necessitating that the display be less intrusive. Whereas less intrusive displays are less likely to capture the driver's attention, more intrusive displays are likely to annoy the driver. Thus multiple stage displays could minimise the conflict between broader protection and greater annoyance.

The implemented display consists of two distinct warnings, imminent and cautionary. At the imminent level, an immediate corrective action is required to avoid collision. At the cautionary level, attention is immediately required because a corrective action may be necessary. To be consistent with the principles of redundancy gain, which states that when a given message is expressed more than once, the likelihood that the message is correctly perceived increases, the imminent crash avoidance warnings should be presented across at least two modes (Wickens et al., 1998). For automotive applications, presenting messages across more than one sensory modality reduces the possibility that factors degrading the message over one modality is degrading the message across the other modalities.

Previous research measuring several multiple-modality single-stage displays showed that participants started to brake earlier with a visual-plus-non-speech-tone display than with a visual-plus-brake-pulse display (micro-pulse braking). The data suggested that the non-speech tone was the most effective stimuli for accompanying a visual warning signal leading to the explanation that speech requires more time to comprehend and is less appropriate for time-critical instances (Belz, 1997). The visual display used for the ACC system was a car icon, demonstrated to have the largest effect on driver headway selection (Dingus et al. 1997) and

used a multi-stage display featuring the expanding rear-end of a vehicle, designed to emulate the natural optical expansion that occurs when one approaches a lead vehicle. Since drivers naturally use the angular size of the lead vehicle (Groeger & Brady, 1999; van der Horst, 1990; Yilmaz & Warren, 1995) to control their relative position and avoid collision, it was hypothesised that a display that uses size change to code the forward threat level would be immediately understandable and intuitive to drivers. However, although this may hold to be true, in terms of the different modalities available to draw the driver's attention to a critical event, studies have advised against presenting graphical information for warning displays because of the limited time for the driver to respond in an urgent situation.

Structure of the ACC warning system

The input parameters of the system consist of the environment and vehicle data pertaining to both the ACC vehicle and the lead or 'target' vehicle. Additionally, all driver actions are monitored. A driver action is, for example, a deceleration manoeuvre which has direct and immediate vehicular and environmental consequences e.g. distance and relative speed.

For an assessment of driver reactions, the input parameters have to be constantly available. In the simulated environment of the driving simulator, its realisation is easy but in light of a later implementation in a real vehicle, attention would need to be paid in allowing the permanent availability of the sensor data pertaining to the lead vehicle to always be available (even when the ACC system is switched off). The 'Analysis of Driver Actions' (ADA) module collects the input parameters and analyses, based upon specific algorithms, the actual, momentary situation. The driver then receives the targeted information from the corresponding messages sent to the warning output/ MMI module. The warning output/ MMI module then delivers the appropriate acoustic and visual messages received from the analysis of driver actions. The basic structure of the ACC warning system is shown in Figure 59.

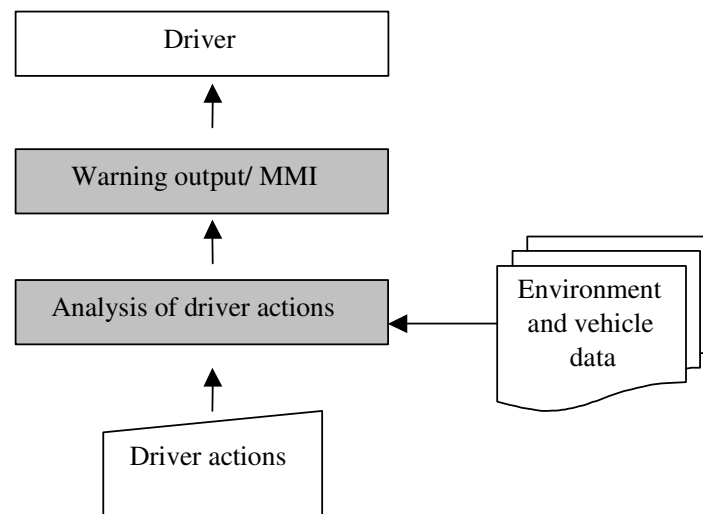

Figure 59. Basic structure of the ACC warning system

The ADA module is responsible for determining the danger potential and for emitting warnings when a specified level has been reached. The basis for it is a potential danger model, consisting of a time reserve function (Kopf, 1994) and a warn deceleration function (Gerisch, 2001).

As mentioned, the warning output (in the enhanced MMI) is multi-levelled. When the driver is driving with active ACC and the system detects a lead vehicle, a visual support information is displayed which communicates at what level (potential danger) the following or approach situation is proceeding. The visual support information is dependent on the a-posteriori time reserve. A warning is emitted when the measured warn deceleration reaches the maximum deceleration of the ACC system. This warning is emitted acoustically and signals a potential take-over situation to the driver. An alarm is emitted when the a-posteriori time reserve reaches a driver-dependent limit. An alarm signal prompts the driver to take immediate danger avoidance action. The alarm is also an acoustic signal, that is clearly distinguishable from the warning signal.

Theoretically, a warning should be emitted before an alarm signal. Nonetheless, in critical situations, a warning (take-over warning) may be simultaneously emitted or very shortly after an alarm e.g. when the lead vehicle is detected very late. In this case, the signals are prioritised and only the alarm is emitted. The information of the ADA module are, as previously mentioned, accordingly delivered to the driver. Table 20 presents an overview of the warnings.

Table 23. *Warning outputs/ MMI information*

Criteria	Modality	MMI
A-posteriori, relatively long time reserve	Visual	Changing colour and size of display symbol
Warn deceleration	Acoustic	Warning signal
A-posteriori, relatively short time reserve	Acoustic	Alarm Signal

The danger model applied is extensively described by (Kopf, 1994). In the following section, the required functions for the personalised warning system are more closely described.

Necessary deceleration and ACC maximum deceleration

The ACC system has a limited deceleration capability. The maximum deceleration level is speed dependent as mentioned in section 2.3.3. The necessary deceleration a_{nec} , is a deceleration measure which constantly calculates the necessary deceleration the ACC vehicle would need to perform for it to adopt the same speed behind the lead vehicle with a pre-defined distance offset.

Necessary deceleration a_{nec} :

$$a_{warn} = \left(\frac{-\Delta v_{rel}^2}{2 * d_{warn}} \right) + a_H$$

with:

Δv_{rel}	Relative velocity
a_H	Acceleration of lead vehicle
d_{warn}	Warning distance, defined as follows:

$$d_{warn} = f_{warn} * d - d_{offset}$$

with:

f_{warn}	Warning factor
d	Actual distance between ACC and lead vehicle
d_{offset}	Distance offset

The necessary deceleration measure can only be calculated when a lead vehicle is in the radar range. The calculated necessary deceleration measure is permanently compared to the ACC maximum deceleration level. If the necessary deceleration exceeds the maximum deceleration rate of the ACC system, a warning signal is emitted.

Time reserve

The time reserve T_{res} is defined as the time at which, with all acceleration parameters remaining constant, the anticipated danger avoidance action must be taken so that a collision can still be avoided—adapted from Kopf (1994). Figure 60 shows the parameters necessary for the calculation of T_{res} .

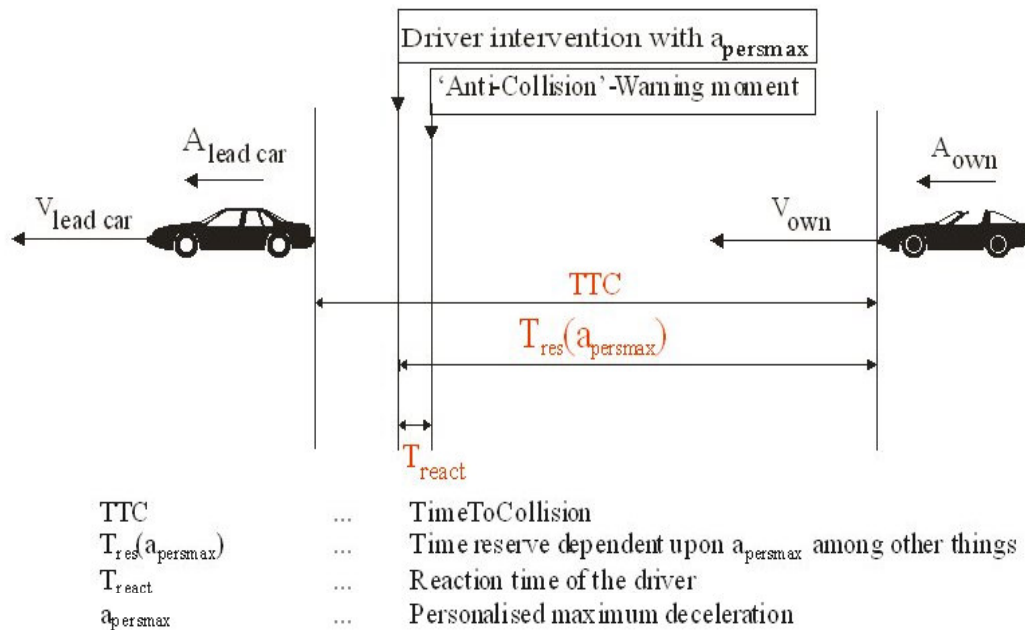

Figure 60. Parameters for the calculation of time reserve

The advantage of using a time measure for the emittance of a warning is that it immediately reacts to the danger avoidance action taken by the driver e.g. deceleration manoeuvre, directly influencing the calculation of the time reserve as well as situational parameters. The driver thus receives a direct feedback of the exactness of his or her action. Moreover, it allows for a personalised reaction time to be integrated in the warning emittance algorithm.

The warning algorithm is equipped with an a-posteriori time reserve. The a-posteriori (objective, momentary) time reserve is defined in terms of situational aspects; these are the measured, objective parameters and driver action aspects, or the most extreme driver action which is here, a maximum deceleration. A careful consideration of the parameters necessary for the calculation of the time reserve leads to the need for a closer look at the maximum deceleration.

The time reserve gives the time that is still available until a collision avoidance reaction is necessary. In the case of an approach or a following situation, it is the maximum deceleration which is presumed to correspond to this reaction. The time reserve is thus calculated with the maximum potential deceleration a_{Epot} .

The maximum potential deceleration a_{Epot} varies from driver to driver. A maximum deceleration is also differently performed from driver to driver. Therefore, drivers' personalised maximum deceleration, has to be extracted and replace the maximum potential deceleration. This was achieved through an individualisation drive in which an average personalised maximum deceleration was calculated from a series of hard decelerations. The calculation of drivers' personal maximum deceleration rates was made on the basis of the five

highest deceleration rates. The mean of the deceleration peaks were averaged and the mean was directly incorporated in the warning algorithm for the experimental drives.

Analytical measurement of the time reserve

As previously mentioned, it is assumed that the ideal step function of the maximum braking deceleration, or the highest value of a_{Epot} can be accepted. The situational aspects are described by the speed (v_O and v_L) and the actual acceleration (a_O and a_L) of the ACC and lead vehicles and by the distance between both vehicles. A real time algorithm for the calculation of the time reserve based on (Kopf, 1994) is described below:

In the first instance, based on the criteria set by the Time-To-Collision, it is checked whether the situation ahead poses a potential danger. If the $TTC < \infty$, a collision will take place and the calculation of the time reserve is expedient. Under the premise that the lead vehicle does not come to a complete stop, the time reserve T_{res} can be resumed with $\Delta a = a_O - a_L$ for:

$$T_{res} = -\frac{\Delta v}{\Delta a} \pm \sqrt{\frac{\Delta v^2}{\Delta a^2} - \frac{2d(a_L - a_{Opot}) - \Delta v^2}{\Delta a(a_O - a_{Opot})}} \quad \text{for } \Delta a \neq 0$$

$$T_{res} = \frac{-d}{\Delta v} + \frac{\Delta v}{2(a_H - a_{Epot})} \quad \text{for } \Delta a = 0, \Delta v \neq 0$$

$$T_{res} = \infty \quad \text{for } \Delta a = 0, \Delta v = 0, d > 0$$

$$T_{res} = 0 \quad \text{for } \Delta a = 0, \Delta v = 0, d \leq 0$$

Due to their singularity and the many different possible scenarios, the formulas are not practical for operational use but are useful for analytical approximations. For operational use, the iterative algorithm developed by Kopf (1994) was implemented.

Development of the personalised warning system HMI

Using the personal maximum deceleration value, the time reserve and the time-to-collision are specified on the basis of the above mentioned iterative algorithm. Furthermore, the previously described warning deceleration and ACC maximum deceleration are calculated. At each cycle, calculation ends the analytical part (analysis of the driver reaction) and the warning outputs begin delivering to the HMI. According to whether the standard or the enhanced ACC warning systems were used, the HMI differed. The warning outputs of the standard ACC warning HMI were based on the ACC HMI in the BMW 7 series. From three vehicle symbols, two signal differences in no lead vehicle detected and lead vehicle detected mode. The third symbol has a warning triangle above the vehicle icon and is displayed simultaneously to an acoustic alarm signal when the warning deceleration exceeds the ACC maximum deceleration.

The warning output of the enhanced version is based on the calculation of the time reserve issuing the driver with a situative warning of the actual danger level. The driver receives six different visual signals dependent on the calculated time reserve and on his personal driving style. The first two mode indicators are identical to the ones in the standard HMI. The next four visual indicators change in colour as well as in size according to criticality. At the most benign level, a green car icon is displayed, at the intermediate danger level, it changes to orange, then red. At the most critical level, when immediate intervention is required, the icon increased further in size and a crash-like graphic was superimposed on the car icon. The display signals that the ACC system is active and in follow-mode. The changes indicate that the time reserve is smaller than a defined threshold value. The threshold values were 6 s, 4 s, 1,5 s and 0,3 s, respectively, from the least to the most critical danger level. Additionally, two acoustic signals were emitted. Firstly, a warning gong was emitted when the warning deceleration exceeded the maximum deceleration. The gong was a redundant information on the criticality of the situation, with regards to the maximum braking capacity of the ACC system. Secondly, an acoustic alarm signal was simultaneously emitted with the 'crash symbol' display, which alerted drivers of the necessary take-over and as well as the appropriate braking intervention force required.

Hypothesis 1: Response criterion in take-over situations is dependent not only on learning, i.e. getting used to the system and being more comfortable with predicting the systems behaviour over time, but also on an individual 'threshold', based upon an internal reference which can be adjusted, especially in the learning phase, by targeted information. A minimised number of surprise reactions would be shown by a reduced amount of panic braking. The reduced number of misses and false alarms demonstrate the drivers' increased ability to predict the need for intervention.

Hypothesis 2: Feedback timing is more crucial than feedback specificity in situations demanding rapid decision-making and response times. It was expected that the two-step, personalised warning system would reduce participants' reaction times in take-over situations, increasing time-to-collision in these scenarios. Drivers procedural knowledge and performance, as measured by the number of safer reaction times (less near misses and increased distances) and correct responses (appropriate braking force and intervention rates) will be markedly higher for drivers in the enhanced group.

The impact of the personalised warning interface on drivers' performance was also tested in terms of mental workload. A secondary task measure was chosen over physiological measures as very few physiological measures can reliably measure event-related, short-lasting variations in workload, being mainly suited for measuring workload over longer periods of

time. Recent research has shown that Peripheral Detection Task (PDT) that requires drivers to detect and react to peripherally presented stimuli is a very sensitive method of measuring peaks in workload induced by a critical scenario. The more demanding the task, the more cues will be missed and the longer the response times to the Peripheral Detection Task. The task will feature the same as that described by Martens & Van Winsum (2000) and Olsson & Burns (2000), where drivers are required to respond as soon as a red square is detected. The stimulus was overlaid in the projected simulation and presented in one of three positions as described by Baumann et al. (2003). A higher RT and a higher fraction of missed signals (number of missed divided by total number of stimuli) is interpreted as the result of higher workload. The effect of the enhanced interface on drivers' mental workload would be demonstrated by an increased hit rate ($HR_{pdt_{enh}} > HR_{pdt_{sta}}$) and reaction time ($RT_{pdt_{enh}} < RT_{pdt_{sta}}$) towards the displayed stimuli as measured by the Peripheral Detection Task (PDT).

Hypothesis 3: Drivers allocated to the enhanced group will have reduced workload levels and workload is predicted to decrease more rapidly (recovery) following critical and semi-critical situations.

6.2.2 Methodology

6.2.2.1 Design

A 2 (scenario) x 2 (display) mixed design was used. The related measures independent variable was scenario type. The unrelated measures independent variable was display type.

The scenario types—approach to a lead vehicle and decelerating lead vehicle—were attributed four and three levels respectively. Each display type was analysed separately at each level of the scenarios. The approach to a lead vehicle scenario constitutes of four levels: approach with difference velocity of 20 km/h, 40 km/h, 60 km/h and approach to a standing vehicle. The decelerating lead vehicle scenario constitutes of three levels: -1,5 m/s², -3,0 m/s² and -4,5 m/s².

Display type had two levels: ACC standard display and ACC enhanced display i.e. personalised two-step warning display.

Independent variables

The levels of each scenario type were chosen to represent situations within the regulating capabilities of the ACC system and beyond the system limits, in which participants must

actively intervene. The levels of each scenario type are explained below and summarised in Table 24.

In the approach to a lead vehicle scenario, four levels were chosen. At a relative speed difference of 20 km/h and 40 km/h the system's decelerating capabilities could handle the situation. However, an approach to a lead vehicle with a relative speed difference of 60 km/h is in excess of the system's capabilities, in which case, an intervention of the driver was necessary. The third level is the most extreme case of approach situations. The approach to a standing vehicle, such as the tail of a traffic jam, always requires driver intervention as the system does not react to standing objects.

As the participants were instructed to set the ACC system speed at 130 km/h, the different levels of approach scenario meant that participants approached a lead vehicle driving at a constant speed of 110 km/h, 90 km/h and 70 km/h respectively. The final level of this scenario is an approach to a standing vehicle. In the case of a still or very slow moving traffic jam on the motorway, the difference velocity at which participants approach the last vehicle in the jam will be up to 130 km/h.

Three levels were chosen in the car-following scenario in which the difference in speed between the participant vehicle and the lead vehicle is zero, when the lead vehicle suddenly applied the brakes. The first level was a mild deceleration, $-1,5 \text{ m/s}^2$, which the system could cope with. At the second level, a medium deceleration force of -3 m/s^2 was applied. At this level, a driver intervention is necessary as the deceleration force was slightly in excess of the ACC's deceleration capability. The hard deceleration level, $-4,5 \text{ m/s}^2$ was distinctly beyond the system's own decelerating capacity.

At the mild deceleration level, the lead vehicle decelerated at a constant rate of $-1,5 \text{ m/s}^2$ for 7 s; at the medium braking level, the lead vehicle decelerated at a constant rate of $-3,0 \text{ m/s}^2$ for 5 s and at the hard deceleration level, the lead vehicle decelerated at a constant rate of $-4,5 \text{ m/s}^2$ for 3 s.

All the levels of the traffic scenarios represent category B situations - situations which require more learning with experience, in which driver intervention is sometimes necessary (see section 5.1.3.3). The third level of the approach scenario, however, represents a category A situation, which the system is not designed to cope with, in which driver intervention is always necessary.

The scenarios did not feature in any special rank order. They remained in the same order within each lap of the course but the two laps in drive 1 and the two laps in drive 2 were randomly allocated to participants in order to counterbalance practice effects.

Table 24. *Levels for the independent variable 'scenario'*





Take-over scenario type	Scenario levels
Scenario 1. Approach to a lead vehicle (own and lead vehicle drive with a constant speed difference towards one another).	v_diff = 20km/h v_diff = 40km/h v_diff = 60km/h Approach to standing vehicle
Scenario 2. Decelerating lead vehicle during car following (following situation with sudden lead vehicle deceleration).	a = -1,5m/s ² a = -3,0m/s ² a = -4,5m/s ²

The independent variable ‘display type’ refers to the different types of warning interfaces attributed to participants. Participants were randomly ordered to the standard and enhanced display conditions. Both standard and enhanced displays featured the standard mode indicators i.e. a transparent as well as the black-filled vehicle symbol to indicate whether ACC is working in Cruise Control mode or in following mode.

The warning interface of the standard display consisted of the standard ACC soft-sounding auditory signal, simultaneously emitted with the graphical red triangle warning signal superimposed on the black vehicle symbol in the speedometer. Table 25 shows the graphical symbols and summarises their meanings.

All the symbols in the ACC standard display are emitted directly in relation to the ACC system status. The transparent vehicle symbol signals that the ACC system is active and that it is working CC mode (i.e. keeping a constant set speed). In a continuous movement, the vehicle symbol loses its transparency to signalise that the ACC system has detected a vehicle and is functioning in follow-mode (i.e. it is regulating the speed and the distance to the lead vehicle). A warning is emitted either when a deceleration beyond the immediately available ACC deceleration is required or when the lead vehicle is deemed to be too close to avoid a collision if a high deceleration force was necessary.

Table 25. ACC Symbols for Standard Display

ACC Symbols	Meanings
	ACC functioning in Cruise-Control mode
	ACC functioning in Car-Following mode
 simultaneous 	Warning Signal: ACC has reached its maximum deceleration An intervention is not always necessary

The warning interface of the enhanced display features two levels. It keeps the ACC-dependent information but uses the warning of the standard system as an interval auditory signal. Independently of the ACC system's functioning, the second informational level is a personalised warning system based on the danger criticality of the situation and the need for intervention during take-over situations. The graphical display was based upon the mean value of drivers' preferred maximum personal deceleration rate acquired through the personalisation drive. The timing and changes of the graphical display was thus personalised to each driver.

Independently of the ACC system functioning, the sensor data provided a continuous output. The continuum was divided into a few discrete levels, which represented the level of urgency with which the driver had to intervene. Changes in the luminance, size and colour were coded for each level of the visual display according to the urgency of intervention. All visual warning displays (here: yellow vehicle symbol) in the standard and enhanced systems were positioned in the speedometer as shown in Figure 61.



Figure 61. Visual warning display in speedometer









The visual display consisted of a yellow, an orange and a red vehicle symbol which increased in size. The yellow symbol was 15% bigger than the transparent and black vehicle symbols; the orange symbol was 30% bigger than the yellow symbol and the red symbol was 45% bigger than the orange symbol. The yellow symbol signalled a situation to which the driver needed to be alert as it could demand active intervention. At this time, however, depending on drivers' preferred maximum deceleration, drivers still had considerable time before braking became a necessity. The next criticality level was signalled by an orange symbol, which warned drivers that the situation had become more critical and the time for them to brake with their maximum personal deceleration was shorter. The red symbol did not yet signify that an

immediate braking action was necessary but warned the driver that the time to intervene was very short. Table 26 shows the graphical symbols as well as the timing of the auditory warning and alarm signal and summarises their meanings.

The final graphical warning display simultaneously occurred with an auditory signal. This functioned as a collision avoidance alarm signal. The graphical display is the same size as the red symbol but indicates by means of a crash symbol the urgency of the situation. Similarly, clearly distinguishable variations in the tone and frequency of the alarm auditory signal coded the changes in intervention urgency. At this stage, avoiding an imminent collision required drivers to intervene with their maximum preferred deceleration rate.

The acoustic signals automatically switch off as soon as the driver applied the brakes or when the necessary distance to the lead vehicle was re-established. The graphical display was bi-directional. In the case of a light braking manoeuvre, the warning graphic symbols will automatically reverse to the previous state until a safe time reserve has been re-established.

Table 26. ACC Symbols for Enhanced Display

ACC Symbols	Meanings
	ACC functioning in Cruise-Control mode
	ACC functioning in Car-Following mode
	Interval Warning Signal: ACC has reached its maximum deceleration An intervention is not always necessary
ACC Symbols	Meanings
	The time until an intervention with your maximum personal deceleration is necessary is relatively long
	The time until an intervention with your maximum personal deceleration is necessary is short
	The time until an intervention with your maximum personal deceleration is necessary is very short
 simultaneous 	Collision Avoidance Alarm Signal An immediate brake-reaction with your maximum personal deceleration is necessary!

Dependent variables

The dependent variables consist of measures for the evaluation of drivers' procedural knowledge and performance. As measured by the number of safer reaction times (less near misses and increased distances), correct responses (appropriate braking force or adequate deceleration i.e. less overshoot) and intervention rates. Learning is measured on the basis of driver's ability to show the correct reactions as well as leaving out incorrect ones. From the number of hits (NH) and false alarms (NFA), the sensitivity of the warning display can be measured whereas the misses (NM) and correct rejections (NCR) enable to calculate its specificity.

Other measures used to determine drivers' performance levels were drivers' maximum deceleration force (m/s^2), a useful measure for determining the number of 'panic braking' (PB) situations; reaction times (RT: time, in seconds, elapsed between the lead car applies the brakes and the driver applies the brakes); distance at intervention (distance, in metres, from the lead vehicle when the driver applied the brakes) as well as Time Reserve (TR) and Time-To-Collision (TTC) at intervention; minimum distance (shortest distance reached to the lead vehicle) as well as minimum Time Reserve and Time-To-Collision; distance error (DE: the difference in the distance between the lead vehicle during following and the distance to the lead vehicle at standstill, after each scenario).

Further, measures related to overall driving performance will be measured i.e. speed (km/h), braking force (N), lane maintenance and lane exceedings (TLC).

Subjective evaluations will be collected by means of questionnaires attributed after each experimental drive. Additionally, a peripheral detection task (PDT), including a choice-decision will measure participants' workload peaks as well as their recovery effect in both conditions. A further dependent variable is the 'learning test' drive. The same situations measured in the first section of the first experimental drive will be tested again at the end of the learning period in order to test drivers' learned behaviour.

Parameters related to the dynamic car data i.e. speed, brake force, acceleration, steering wheel angle etc., as well as to the ACC sensor data i.e. time reserve, time-to-collision, distance to lead vehicle, acceleration of lead vehicle etc., are recorded on line during the actual drive. The dependent variables that are specifically analysed in conjunction with the occurrence of the independent variable 'scenario type' are extrapolated from these parameters and compared between display conditions. The only dependent variable that can not be directly extrapolated from the data are the subjective evaluations. These evaluations covered subjective changes in understanding of the system limits and ability to predict the need for intervention as well as subjective impressions of safety and comfort. Table 27 shows a list of the dependent variables.

Table 27. *List of dependent variables*

Dependent variables	
Reaction time (s)	Maximum deceleration (m/s ²)
Distance (m) at intervention	Mental workload
T_{res} , TTC (s) at intervention	Time to Lane Crossing (s)
Minimum distance (m)	Speed (km/h)
Minimum T_{res} and TTC (s)	Brake force (N)
Distance Error (m)	Subjective evaluation
Necessity of intervention (N H, FA, M, CR)	

6.2.2.2 Participants

Twenty-four participants were involved in the study. The sample consisted of 15 males and 9 females. Half were attributed to each condition in a way that both groups would be kept homogeneous with regards to age, gender, braking style preference (mean maximum personal deceleration), driving experience (number of years since passing the driving licence, number of km driven per annum and total km driven) and simulator driving experience (total driving time in the BMW simulator effectuated in previous experiments). All participants were BMW external. They were recruited by telephone and selected from the BMW driver database on the basis of having previous experience of simulated driving in the BMW simulator and of having no prior experience of driver assistance systems.

The age of the participants ranged from 30 to 54 years ($M = 37$) in the standard group. The group consisted of 7 males and 5 females. In the enhanced group, the age of the participants ranged from 24 to 51 years ($M = 37$); the group consisted of 8 males and 4 females.

The personal maximum deceleration of the participants driving with the standard HMI ranged from -4.1 m/s² to -8.8 m/s² ($M = -6.9$ m/s², $SD = 1,37$) and the maximum deceleration for drivers of the enhanced HMI ranged from -5 m/s² to -8.1 m/s² ($M = -6.8$ m/s², $SD = 1,13$).

The number of years a valid driving licence was held ranged from 12 to 35 years ($M = 18.7$ years) for the standard group and from 7 to 33 years ($M = 19,3$ years) for the enhanced group. The level of driving experience of the standard group ranged from 10,000 to 70,000 kilometres per year ($M = 22,900$ km) and the level of experience of the enhanced group ranged from 5,000 to 45,000 kilometres per year ($M = 21,800$ km).

The level of driving experience in terms of total driven kilometres was approximated by each participant by choosing one of four possibilities: <50,000 km; 50-100,000 km; 100,000-500,000 and >50,000 km. No participant had driven less than 50,000 kilometres and only 1 driver in each group had driven between 50 and 100,000 km. Most participants were experienced drivers, with 69% in the standard group and 76% in the enhanced group, having

driven at least 100,000 km. Three drivers in the standard group and two in the enhanced group had more 500,000 km driving experience.

In terms of simulator experience, participants in the standard group had previously completed between 45 minutes and 200 minutes ($M = 120$ min, $SD = 57,24$ min) driving in the BMW simulator. Simulator experience of participants assigned to the enhanced group had a range of 40 minutes to 160 minutes ($M = 113$ min, $SD = 34,69$ min) driving time in the BMW simulator.

6.2.2.3 Apparatus

The BMW driving simulator was used as measurement instrument for the study (see section 4.2). The traffic situations were programmed and tested internally. The new BMW simulator software framework SPIDER was employed, which enabled more degrees of freedom for the operator in controlling the drives and the events as well as an improved, user-friendly interface for the control of the experiments (Strobl, 2003).

For the integration of the personalised warning system, the visual display sequences were developed for projection onto the speedometer. The design was reconfigurable, facilitating the display of multiple-stage multicolour icon sequence for communicating the system alert levels.

For the peripheral detection task, a red square on a black background was overlaid onto the projection. The stimulus appeared at fixed positions to the left and to the right of the road, at equal distance from drivers' eye level. The stimulus was positioned at a horizontal angle of 14° , a vertical angle of -1° and at a distance of 2.06 meters from eye level (see Figure 62).

The indicators, both left and right, were used for drivers to respond to the presented targets. The indicator levers were sensitive enough to react to a simple nudge. As soon as the indicator was nudged, the stimulus disappeared. Drivers had to respond by nudging the indicator located on the same side as the stimulus. Reaction time (RT) was measured in ms.

Drivers were trained at the task during the introductory drive, where the stimulus appeared randomly on either side at random intervals. During the experimental drives, the location of the stimuli was random, but the time at which it appeared was set by the onset of the scenarios and driver workload and after the danger was over, during the recovery period.



Figure 62. Peripheral Detection Task (PDT) Stimulus

As in the first experiment, both drivers and the road were filmed using two cameras. One positioned on the dashboard for the driver and one on top of the car to capture the entire driving scenery. Both views were condensed onto one screen for a picture in picture effect using a Panasonic view mixer, which blended the driver into the top right hand corner of the screen. This picture was simultaneously recorded by a video recorder which, using a self-generated timecode could then be viewed and directly matched to the data.

6.2.2.4 Procedure

Participants came twice, each time for a period of 2 hours. The first and the second testing period were separated by a one week interval. This interval time was kept constant although due to cancellations, sometimes had to be re-scheduled for a slightly longer or shorter time interval. The number of days between the first and second testing period ranged from 6 to 10 days ($M = 7.2$ days) for all participants. 75% of participants returned after exactly 7 days.

On the first day, a 10-minute introductory drive served as recapitulation of the driving in the simulator as all drivers had previously gained experience with simulated driving. The simulated road was a section of the motorway that was used for the experimental drives.

This was followed by a 10-minute individualisation drive. This drive consisted of following a lead car that varied between making small changes in its speed (i.e. varying between 120 km/h and 100 km/h) due to an uneasy flow of traffic ahead and making abrupt decelerations, ranging from medium (i.e. braking quickly down to 70 km/h) to hard (i.e. braking down to 40 km/h). In total, five hard, abrupt decelerations, forcing participants to a braking reaction, were carried out in order to identify driver-specific maximum decelerations. The simulated road

was a particularly congested dual-carriageway to prevent steering reactions from the drivers. Drivers were instructed to follow the lead vehicle and not to overtake.

The next drive was a 15 minute ACC introduction drive on the motorway. Drivers had previously read about the ACC system's functionality and were briefed orally about the system's operation. The aim of this drive was for participants to get accustomed to the system. Participants were firstly prompted to complete a series of simple operational procedures. Drivers were instructed to switch the system on, set a desired speed of 120 km/h, reduce the set speed to 90 km/h, to de-activate the system and resume to the last set desired speed. Drivers performed these operational procedures on a motorway lane free of traffic. Participants were then instructed to follow a lead vehicle travelling at 130 km/h for the entire duration. The simulated road was a mixture of straight and curved sections in which the lead vehicle would vary its speed between 80 km/h and 120 km/h only by releasing the accelerator or braking very slightly in order to prevent exceeding the deceleration capabilities of the ACC system.

The fourth and final drive of the first day was a 1 hour experimental drive. Participants drove with a functionally identical ACC system. The HMI of the system differed depending on the group they had been allocated to. Participants were instructed not to overtake and to keep a constant speed of 130 km/h. If braking was necessary, they should resume to this speed as soon as possible. The simulated road was a mixture of straight motorway sections and curved slip-road sections. The three motorway sections joined by three slip-roads have been closely matched to the road-infrastructure surrounding Munich, thus for most participants, the drive consisted of a familiar stretch of road. Each of the three motorway sections were driven twice. Four to five scenarios, depending on the length of the motorway section were planned for each one. Each scenario was provoked by other simulated road users in the most natural and logical way in order for it appear as natural as possible to the driver e.g. approach to a slower vehicle after joining the motorway, sudden hard braking due to traffic build up, or to a traffic jam on the motorway. Each level of both scenario types was experienced four times by the time all three motorway sections had been driven on once. A braking lead vehicle scenario thus occurred 12 times and an approach to a lead vehicle 16 times. Since participants drove all motorway sections twice, the total number of pre-programmed events was 56 per experimental drive. The scenarios are described in detail below.

The second experimental day also started with an introductory drive, this time, however, directly with use of the ACC system. It was followed by a 1-hour experimental drive which was the same as on the first day except for the order in which the scenarios appeared.

The third and final drive was a 20-minute experimental drive in which participants experienced each level of every scenario only twice—a total of 6 braking lead vehicle events and 8 approach to a lead vehicle events—on an unfamiliar motorway. Drivers were given the same instructions as during the first two experimental drives. The major difference between this course and the course used for the first two experimental drives is its very different appearance due to the elaborate and constantly changing scenery and road structure i.e. hills, curves etc.

The experimental drive represented a “learning-test” in which the accumulated knowledge of the 2-hour experimental drive was put to the test in a new environment. The outline of each experimental day is shown in Table 28.

Table 28. *Study outline*

First experimental day		
Drive sequence	Questionnaires	Duration (min)
	Demographic questionnaire	10
Introduction drive	Drive instructions	10
Individualisation drive	Drive instructions	10
ACC introduction drive	ACC information sheet	15
		5 min break
Experimental drive 1	Drive instructions	60
	Evaluation of ACC HMI	10
		Total time = 120min
Second experimental day		
Drive sequence	Questionnaires	Duration (min)
ACC introduction drive	ACC information sheet	10
Experimental drive 2	Drive instructions	60
	Evaluation of ACC HMI	10
		5 min break
Learning-test drive	Drive instructions	20
	Evaluation of ACC HMI	10
		Total time = 115 min

Description of the simulated road

All seven drives that were completed during this experiment were carried out on two different simulated roads. The introduction drive, the individualisation drive and both experimental drives took place on the so-called A9 course. This is a motorway course only which forms a triangular shape, linking together the A9, A92 and A99 motorways that lie to the north of Munich. The learning test drive takes place on the so-called Munich-2000 course (see section 5.2.2.4 for a description of both courses).

Description of experimental drive 1 and 2

Experimental drive 1 took place on the A9 course. The drive constituted driving twice around the entire course. Particular attention was made in programming the scenarios so that they would occur seemingly and logically during the entire course and appear as natural as possible to the driver. Each motorway section was planned so that at the end of each lap (all three motorway sections) participants had experienced all levels of both scenarios twice with the exception of the approach to a standing vehicle which they only would encounter once per lap.

Within each lap of the course, the situations remained the same for all participants, however, the order of the laps of each experimental drive was randomly assigned to each driver to prevent learning effects. As two laps existed for each experimental drive, all four combinations of the order in which they appeared were randomly assigned. As each level of every scenario is repeated four times in experimental drive 1 and 2, the figures have been omitted here. The order in which the scenarios appear in the first and second lap of the first and of the second experimental drive can be presented in Appendix D.

Description of the learning test drive

The learning test drive took place on a new course, the so-called Munich-2000 course. It also features a motorway segment but is a much more varied course than the A9. The drive that participants executed on this course was 25 km long and began at Munich City Airport. Drivers were instructed to join the motorway and drive until they reached the inner city ring road. At this point they effectuated a right hand turn onto the ring road. They drove around it until they reached the same motorway again, and drove back to the airport. The course was chosen to contrast with previous motorway drives. Firstly drivers started from a known landmark and took a B-type road to join the motorway. The motorway itself had two-lanes but contrasts to the former motorways in the featured curves and hills as well as the elaborate and constantly changing environment. Drivers drove through a small city segment before driving back on the motorway to the airport. Every level of each scenario was experienced twice by participants in each group.

6.2.3 Results

The description of the experiment results follows the order of the hypotheses that were formulated in the introduction. Differences in participants' driving behaviour in terms of Time-to-collision (TTC), Reaction Time (RT), unnecessary interventions, Distance Error (DE), panic braking and adequate deceleration will be compared between both groups at every level of each scenario for all three drives. Then, the results on participants workload, based upon the hit rate and reaction times on the PDT task, will be presented and compared between both groups. The final section will cover the questionnaire results of participants' subjective impressions of the system's interface in terms of understanding, efficiency, safety and comfort. An alpha level of .05 was used for all statistical tests. The data was analysed using a two-way ANOVA for mixed designs, with drive number (experimental drives 1, 2 and 3) as the related samples variable and display condition as the unrelated samples variable (standard and enhanced display).

TTC at intervention

Both minimum TTC and TTC at the time of participants' intervention was measured for each level of each scenario. Figure 63 and Figure 64 show TTC at intervention for different levels of both scenarios. The levels of each scenario necessitate driver intervention to avoid a collision with the lead vehicle. These levels of the scenarios were selected as they represent the most learn-intensive variation. At a difference velocity of 40 km/h, the deceleration of the ACC system can still, although it might lead to a very close approach of the lead vehicle, prevent a collision. The highest deceleration level, $-4,5 \text{ m/s}^2$ is critical and often caused an immediate brake reaction, regardless of the warning system.

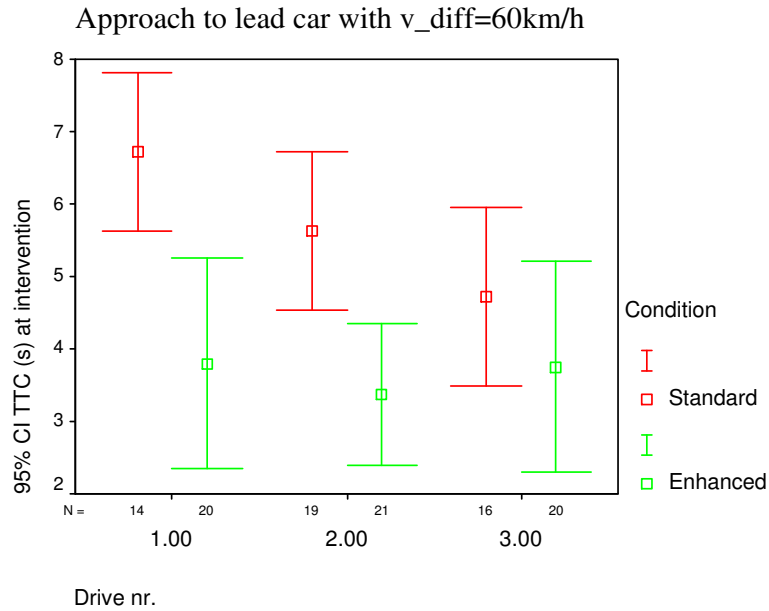

Figure 63. TTC at intervention during approach to lead car scenario at $v_{diff}=60\text{ km/h}$

Figure 63 shows a learning progression in the standard condition. Drivers in the standard group began their intervention at a mean TTC close to 7 s in the first experimental drive. The mean TTC at intervention consistently lowered over all three drives, to under 5 s in the final, ‘learning test’ drive. In comparison, the mean TTC at intervention remained relatively constant, slightly below 4 s, over all three drives in the enhanced group. Interestingly, the mean TTC at intervention level in the standard group is at the entry level in the enhanced condition. There was a statistically significant main effect of display condition, $F(1,104) = 17,29, p = .01$, with drivers in the standard group braking earlier (higher TTC at intervention) than drivers in the enhanced group. There was no significant main effect of drive number, $F(2, 104) = 1,50, p = .22$. The Display x Drive interaction was not significant, $F(2, 104) = 1,31, p = .27$.

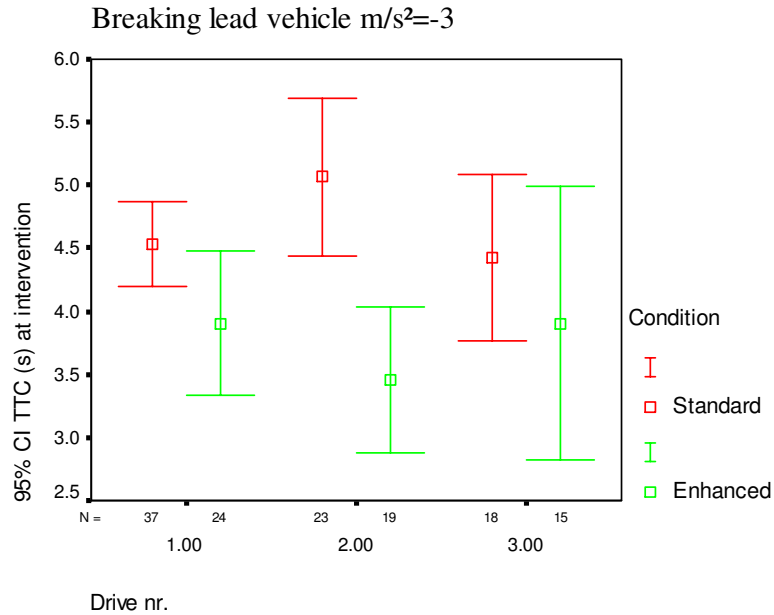

Figure 64. TTC at intervention during braking lead vehicle scenario at level $m/s^2 = -3$

Similarly, mean TTC values at intervention in a car-following situation when the lead vehicle decelerated by $-3 m/s^2$ were lower in the enhanced group compared to the TTC mean values in the standard group during all drives. Again, the mean TTC level achieved in the standard group is close to the mean TTC entry level in the enhanced condition. There was a statistically significant main effect of display condition, $F(1,130) = 14,70$, $p = .01$, with drivers in the standard group braking earlier (higher TTC at intervention) than drivers in the enhanced group. There was no significant main effect of drive number, $F(2, 130) = 0,04$, $p = .95$ or in the interaction Display x Drive, $F(2, 130) = 2,10$, $p = .12$.

The significant effect of the conditions on TTC at this level of the approach and following scenarios suggests a later braking reaction within the enhanced group which is not consistent with the experimental hypothesis.

Distance at intervention

Although TTC was the preferred measurement for comparing participants' understanding of the system limits and their ability to predict the need for intervention due to its exactness, taking account of the vehicles relative speed and accelerations, distance to the lead vehicle at intervention was also calculated. Figure 65 and Figure 66 show the mean distance at intervention in both groups, for the same levels of each scenario type.

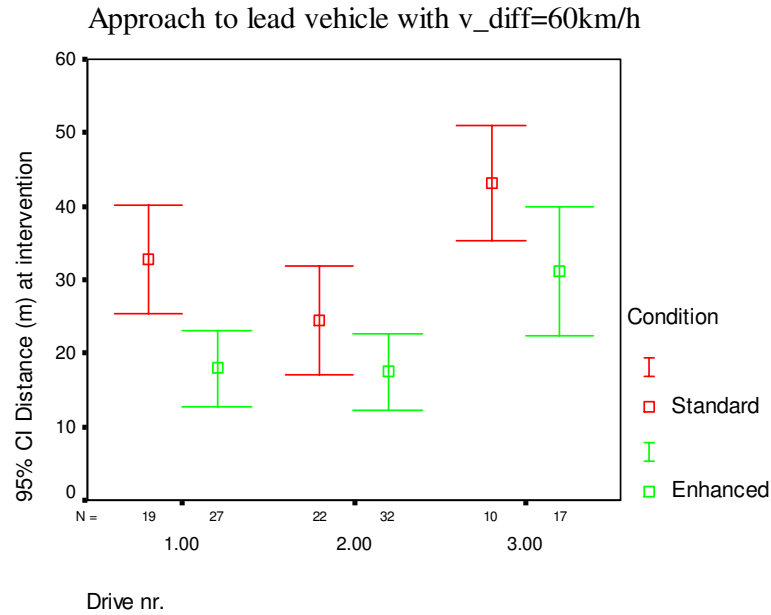

Figure 65. Distance at intervention during approach to lead vehicle with $v_{diff} = 60 \text{ km/h}$

Figure 65 shows that although the mean distance at intervention remains lower in the enhanced group in every drive, the pattern observed is not conserved in drive 3 where both groups' mean distance at intervention increase. There was a statistically significant main effect of display condition, $F(1,104) = 14,49$, $p = .01$, with drivers in the standard group braking at a longer distance to the lead vehicle, than drivers in the enhanced group. There was no significant main effect of drive number, $F(2, 104) = 2,63$, $p = .07$. The interaction Display x Drive was not significant, $F(2, 104) = 0,74$, $p = .47$.

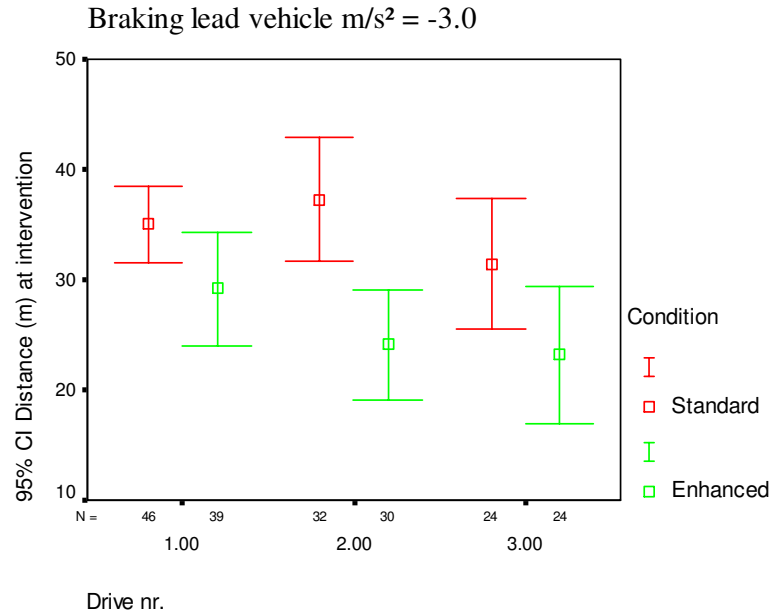

Figure 66. Distance at intervention during braking lead vehicle scenario at level $m/s^2 = -3$

Figure 66 shows consistency between the mean distance and mean TTC at intervention for the middle level of the braking lead vehicle scenario with a considerable reduction in the variation within both groups, especially in the final drive. There was a statistically significant main effect of display condition, $F(1,104) = 13,25$, $p = .01$, with drivers in the standard group braking at a longer distance to the lead vehicle, than drivers in the enhanced group. There was no significant main effect of drive number, $F(2, 104) = 0,67$, $p = .51$. The interaction Display x Drive was not significant, $F(2, 104) = 2,86$, $p = .06$.

Minimum TTC

Minimum TTC was analysed and compared between conditions at each level of both scenarios in all three drives. For comparison with TTC at intervention and for the reasons stated above, minimum TTC is presented at levels $v_{diff} = 60$ km/h of the approach scenario and $m/s^2 = -3$ for the braking lead vehicle scenario. The results are shown in Figure 67 and Figure 68. Calculations of the minimum Tres (s) and minimum distance (m) follow the same trend indicated by the minimum TTC at all levels of each scenario and are therefore not presented.

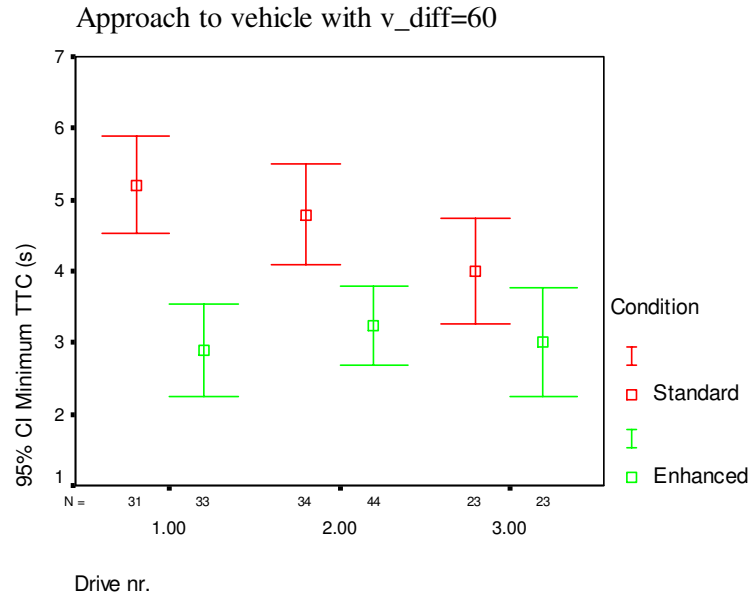

Figure 67. Minimum TTC during approach to lead vehicle with $v_{diff} = 60$ km/h

At this level of the scenario, participants of the enhanced group had considerably lower mean minimum TTC values. Interestingly, the mean minimum TTC values of the standard group follow a downward trend, showing a tendency towards lower TTC values. The level achieved in drive 3 is close to the entrance level shown by drivers in the enhanced group. There was a statistically significant main effect of display condition, $F(1,197) = 25,36$, $p = .01$, with drivers in the standard group closing in less tightly to the lead vehicle in approach situations, than drivers in the enhanced group. There was no significant main effect of drive number, $F(2, 197) = 2,20$, $p = .11$. The main effect of the display condition was qualified by the significant Display x Drive interaction, $F(2, 197) = 3,35$, $p = .03$. Analysis of Figure 67 suggests that the significant interaction results from the higher minTTC values in the standard group compared to the enhanced group in the first drive, relative to the difference in minTTC values between groups in the third drive.

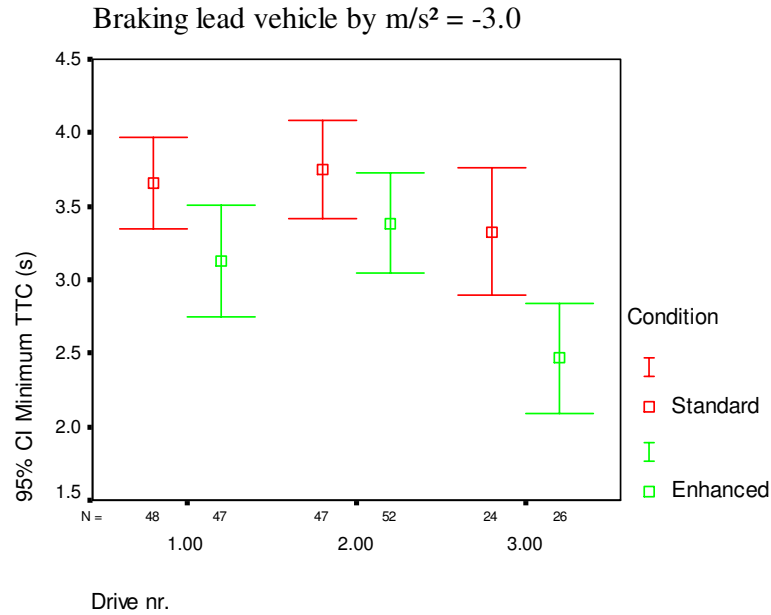

Figure 68. Minimum TTC during braking lead vehicle scenario at level $m/s^2 = -3$

The overall trend is similar at the middle level in the braking lead vehicle scenario. Minimum TTCs in the enhanced group remain lower in every drive and a tendency towards lower minimum TTC levels can be observed over time. There was a statistically significant main effect of display condition, $F(1,228) = 13,46$, $p = .01$, with drivers in the standard group closing in less tightly to the lead vehicle at this level, than drivers in the enhanced group. There was also a significant main effect of drive number, with drivers in the enhanced condition closing in more tightly in the third drive compared to the two first drives, $F(2, 228) = 5,44$, $p = .005$. The Display x Drive interaction was not significant, $F(2, 228) = 0,76$, $p = .46$.

The mean minimum TTC value of the enhanced group in the third drive is the lowest value in both scenarios. The standard distribution of all the events at this level of the braking lead vehicle scenario is shown in Figure 69.

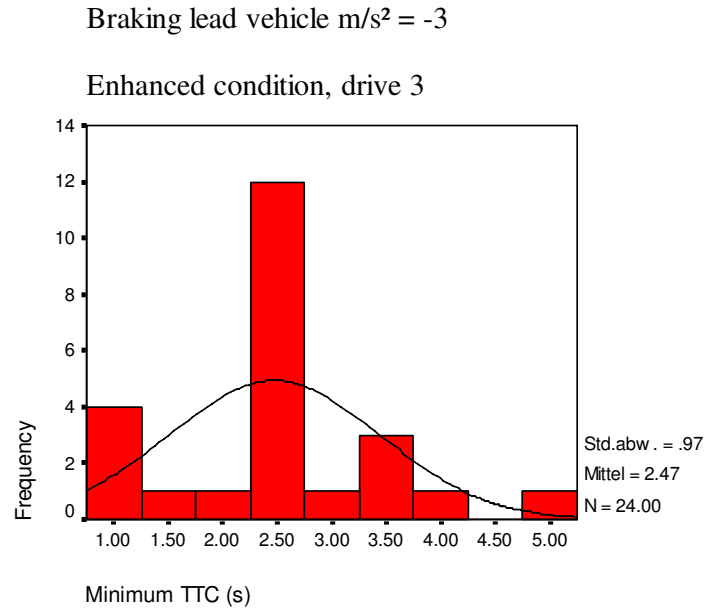

Figure 69. Distribution of min TTC in the enhanced condition, in drive 3

As shown in Figure 69, the minimum TTC was equal or above 2.0 s in more than three-quarters of all events. Only in five cases, do the drivers of the enhanced group intervene with a minimum TTC below 2.0 s. In four cases, drivers wait for the alarm signal before intervening, at which point they must apply maximum deceleration in order to avoid a collision.

Reaction times

Participants' reaction times (calculated as the time elapsed from the actuated brake light of the lead vehicle to brake pedal activation) during scenarios involving a braking lead vehicle were analysed and compared between both groups. The two higher braking levels of the decelerating lead braking scenario were chosen ($m/s^2 = -3.0$ and $m/s^2 = -4.5$) as at the $m/s^2 = -1.5$ level, only a few interventions took place within each group and none of these situations were safety critical. Figure 70 and Figure 71 show drivers' mean reaction times in both conditions over all three drives.

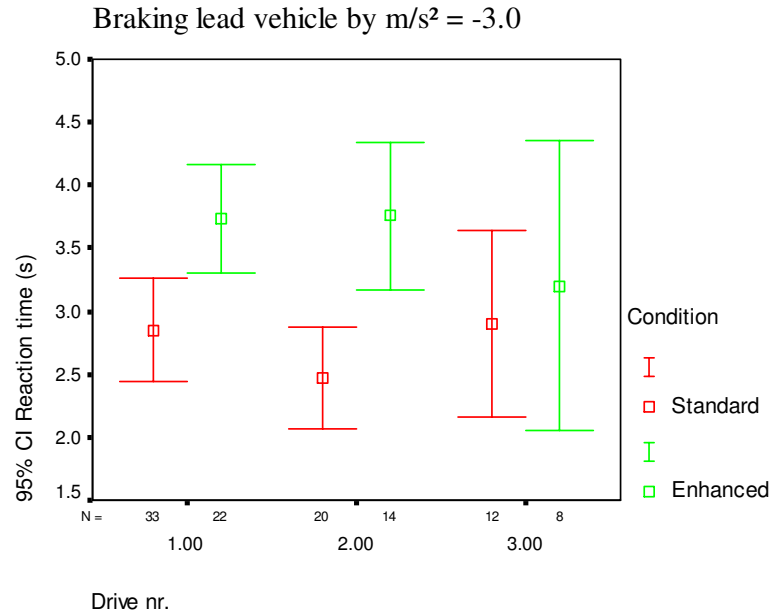

Figure 70. Reaction times during braking lead vehicle scenario at level $m/s^2 = -3$

Figure 70 shows a tendency for delayed intervention in the enhanced condition. Although the mean reaction times of both groups are around 3 s in the third drive, differences between groups are considerably larger in drives 1 and 2 (over 1 s). There was a statistically significant main effect of display condition, $F(1,103) = 13,17$, $p = .01$, with drivers in the standard group having quicker brake reaction times than drivers in the enhanced group. There was no significant main effect of drive number, $F(2, 103) = 0,49$, $p = .60$. The Display x Drive interaction was not significant, $F(2, 103) = 1,29$, $p = .27$.

The significant effect of the conditions on drivers' reaction times at this level of the following scenario is not consistent with the experimental hypothesis.

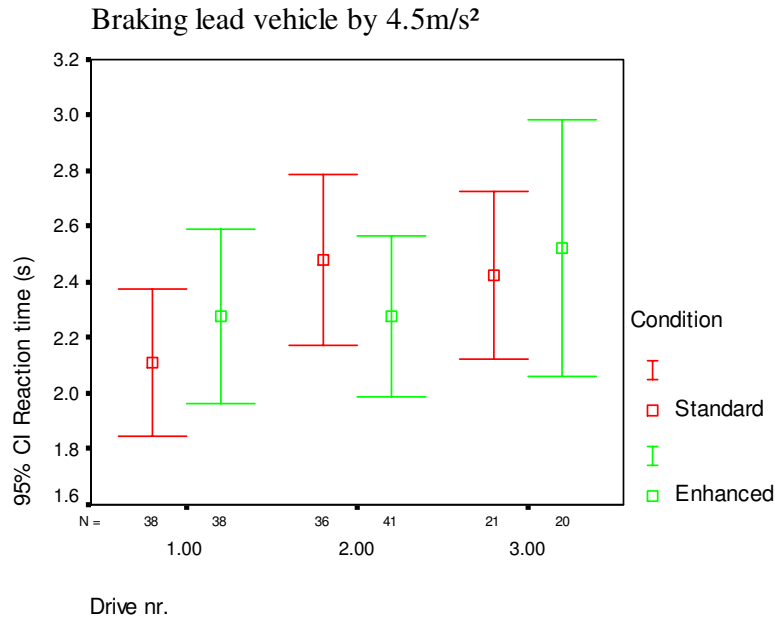

Figure 71. Reaction times during braking lead vehicle scenario at level $m/s^2 = -4.5$

At the most extreme level of this scenario, differences between both groups are less marked. Compared to the middle level of the scenario, the mean reaction times for the enhanced group are now similar to the standard group, which remain low (between 2 and 2.5 s) largely due to the criticality of this scenario level. There was no significant main effect of display condition, $F(1,188) = 0,24$, $p = .87$, or of drive number, $F(2, 188) = 1,55$, $p = .21$. The Display x Drive interaction was also not significant, $F(2, 188) = 0,90$, $p = .40$.

Adequate deceleration

Based upon participants' maximum deceleration rates, it was possible to determine their braking adequacy in proportion to the level of deceleration applied by the lead vehicle. The smaller the difference between the deceleration of the lead vehicle and participants' deceleration, the more adequate the deceleration is. Based upon the hypothesis formulated in the introduction, maximum deceleration rates were compared between groups for the different levels of each scenario. Figure 72 and Figure 73 show the mean maximum decelerations during an approach to the lead vehicle scenario, with a difference velocity of 40 km/h and a braking lead vehicle scenario, with a deceleration of $-3.0 m/s^2$. These two levels of the scenarios were chosen as they best exemplify the most learn intensive aspects of the scenarios. On the one hand, drivers must learn that an active deceleration intervention is not needed although the approach is sometimes very close. On the other hand, drivers must intervene, although at a relatively low deceleration rate as the ACC is capable of undertaking much of the necessary deceleration.

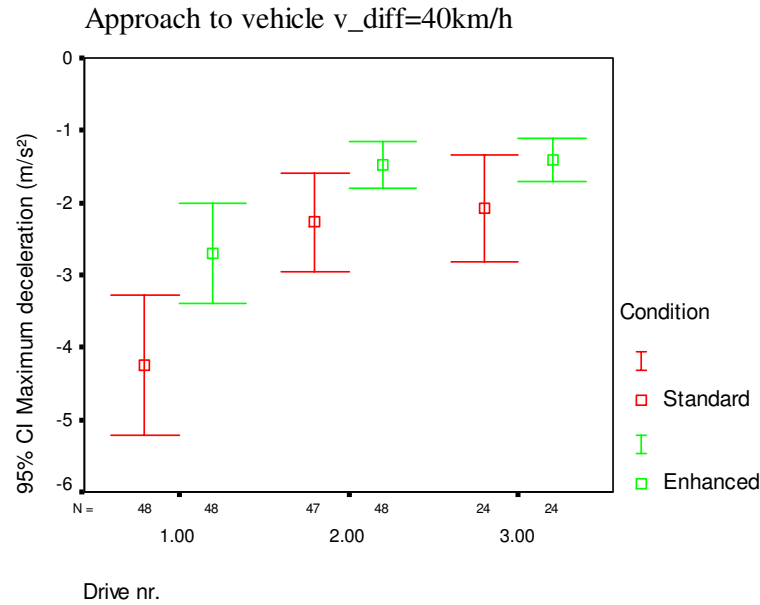

Figure 72. Maximum deceleration during approach to lead vehicle with $v_{diff} = 40 \text{ km/h}$

As Figure 72 shows, the mean deceleration in the standard group is higher in every drive. At this level of the scenario, active driver intervention is principally unnecessary, thus deceleration rates should not exceed -2m/s^2 (the maximum ACC deceleration rate). Thus, all decelerations above -2m/s^2 were conducted by the driver and represent rates of inadequate deceleration. After the first drive, the mean maximum decelerations in the enhanced group remain less than -2m/s^2 , whereas the mean maximum deceleration for the drivers of the standard group remains above this rate over all three drives. The difference, however, in braking adequacy between both groups, is most marked in the first drive. There was no significant main effect of display condition, $F(1,69) = 0,61$, $p = .43$, or of drive number, $F(2, 69) = 1,78$, $p = .17$. The Display x Drive interaction was also not significant, $F(2, 69) = 0,34$, $p = .71$.

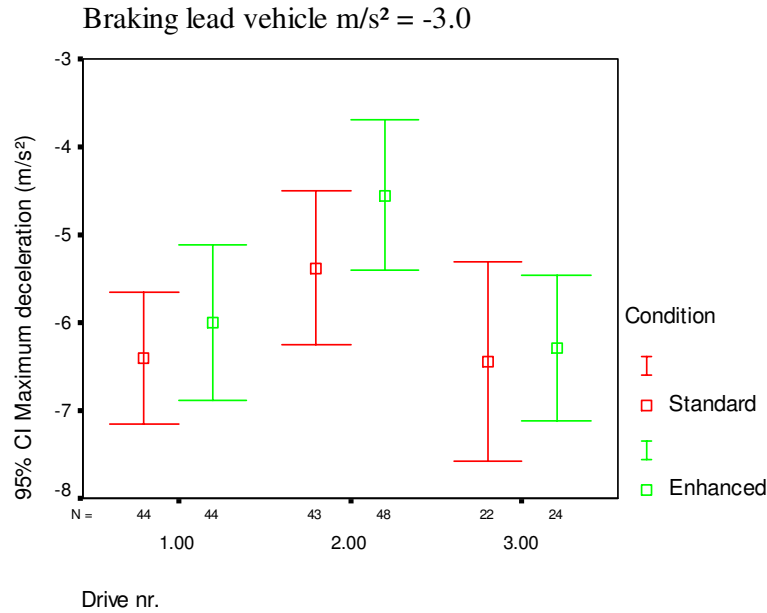

Figure 73. Maximum deceleration during braking lead vehicle scenario at level $m/s^2 = -3.0$

Figure 73 shows the difference in mean maximum deceleration between both groups in a car-following situation when the lead vehicle decelerated by $-3m/s^2$. Drivers' decelerations were considerably higher in both groups compared to the deceleration level of the lead vehicle. The enhanced group's maximum mean decelerations were, especially in the first two drives, lower than in the standard group, indicating a slightly more adequate braking although the variance within groups in each drive was relatively high and comparable in both groups. This trend towards more adequate braking can also be supported when the lead vehicle deceleration rate was $-4.5m/s^2$. However, statistically, there was no significant main effect of display condition, $F(1,187) = 0,64$, $p = .42$, or of drive number, $F(2, 187) = 0,54$, $p = .58$. The Display x Drive interaction was also not significant, $F(2, 187) = 0,15$, $p = .85$.

Intervention necessity

The necessity of participants' interventions was measured at every level of each scenario. Adapted to the signal detection theory, where four outcomes based on the combination of two states of the world (necessity to intervene or not) and two response categories (intervention or no intervention). Drivers' interventions were analysed in terms of the four classes of joint events: hits, misses, false alarms and correct rejections (see Table 18)

Figure 74, Figure 75 and Figure 76 show the percentage number of driver intervention from each of the abovementioned categories. Figure 74 shows the results of the approach to a lead vehicle scenario at the most learn-intensive level, $v_diff = 40$ km/h. At the $v_diff = 20$ km/h and 60 km/h scenario levels, both groups showed a conform picture. Almost 90% of drivers'

interventions were correct rejections at the $v_{diff} = 20\text{km/h}$ level and over 90% of drivers' interventions were hits at the $v_{diff} = 60\text{km/h}$ level.

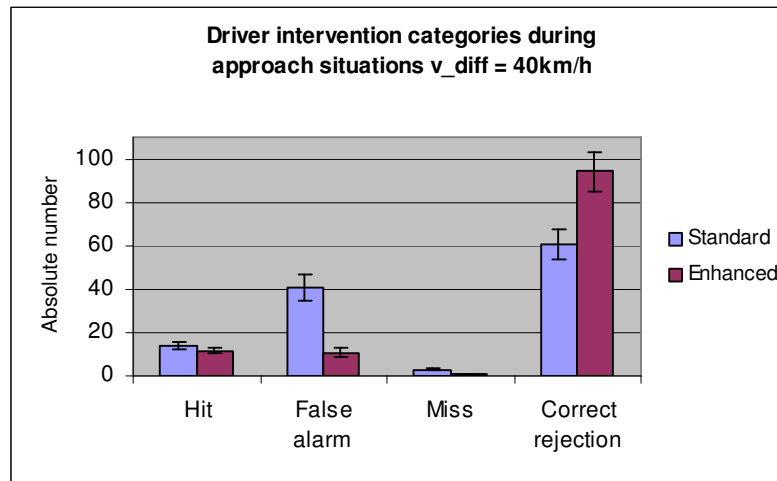

Figure 74. Intervention categories during approach to lead vehicle with $v_{diff} = 40\text{ km/h}$

At the $v_{diff} = 40\text{km/h}$ level, no intervention is necessary. Driver interventions are thus necessarily false alarms. The total number of experienced situations at this scenario level was 119 in the standard group and 117 for the enhanced group. Figure 74 shows that over 90% of participants' reactions were correct in the enhanced condition, whereas only slightly above 50% of participants' reactions were correct in the standard condition. The number of hits indicates situations in which intervention was necessary at this level. This might be attributed to slight differences in the participants' driving behaviours, contributing to the occurrence of such situations. The number of misses in the standard group allude to collisions with the lead vehicle. Two collisions actually occurred in the standard group (see Table 29).

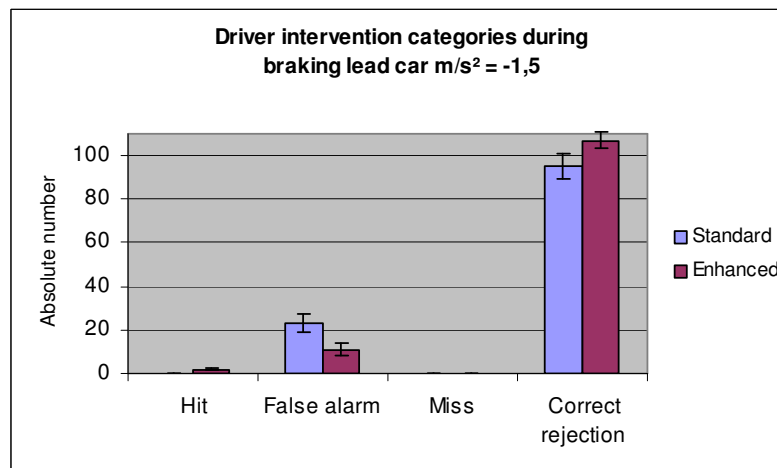

Figure 75. Intervention categories during braking lead vehicle with $m/s^2 = -1.5$

Figure 75 and Figure 76 show the results of the approach to a lead vehicle scenario analysis, at levels $m/s^2 = -1.5$ and -3.0 . At the $m/s^2 = -4.5$ level, both groups showed a conform picture in which almost 95% of drivers' interventions were hits. The total number of experienced situations at this scenario level was 118 in the standard group and 120 for the enhanced group. Figure 75 shows that approximately 90% of driver interventions in the enhanced condition were correct rejections (drivers did not intervene when intervention was not necessary), whereas the figure was approximately 80% in the standard condition. These results are reflected in the false alarm category, in which 10% of the enhanced group and 20% of the standard group's drivers' interventions can be accounted for.

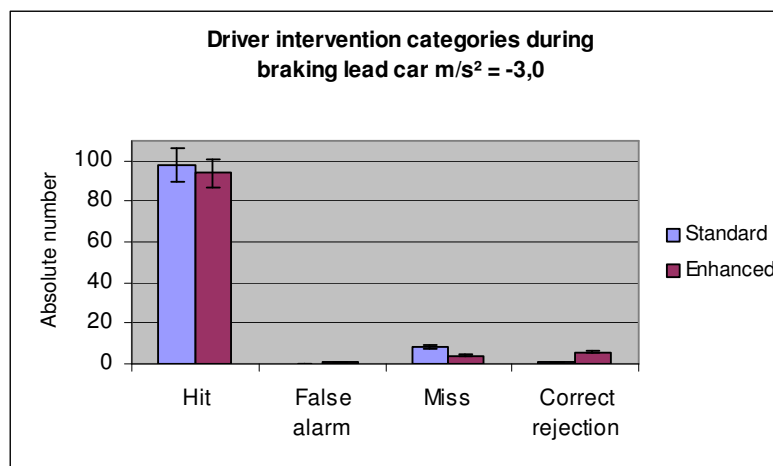

Figure 76. Intervention categories during braking lead vehicle with $m/s^2 = -3.0$

The total number of experienced situations at the $m/s^2 = -3.0$ level of the scenario, was 107 in the standard group and 105 for the enhanced group. Figure 76 shows that over 90% of drivers' reactions were hits (drivers intervened when intervention was necessary) in both groups. The relatively high percentage of missed interventions allude to a number of possible collisions. Table 29 shows that no collisions actually took place at any level of this scenario. This result is possibly due to the calculation of the necessary deceleration filter, for which a deceleration was considered necessary although none was actually needed. In any case, these situations are likely to have resulted from tardier deceleration onsets and represent near miss situations.

The enhanced system showed a reduction in the number of false alarms and an increase in the number of correct rejections during approach situations with $v_diff = 40$ km/h. At this level, the ACC system's deceleration capacity suffices but the close-in to the lead vehicle is the most pronounced. Differences between groups at this level, was marked by the occurrence of misses i.e. collisions with the lead vehicle, in the standard display group. During decelerations of the lead vehicle at the lowest level, when no intervention was necessary, the enhanced

display also reduced the number of false alarms, correspondingly increasing the number of correct rejections. At the $m/s^2 = -3$, however, when intervention is necessary, little differences could be seen between groups. The difference was marked by a higher number of close collisions in the standard group, although no collisions actually occurred. At the most extreme levels of both scenarios, where hard braking interventions are necessary, no differences between groups were found in the lead vehicle deceleration scenario. Similarly to the middle level of the approach scenario, however, at the highest level, a higher number of collisions with the lead vehicle was found in the standard display group.

Panic braking

The number of panic braking situations was analysed for every level of each scenario. Panic braking was defined as a deceleration equal or greater than the mean maximum personal deceleration of the respective group. Thus, in the standard group, a panic braking situation was one in which a deceleration exceeded -6.9 m/s^2 and, in the enhanced group -6.8 m/s^2 . The results are summarised in Figure 77.

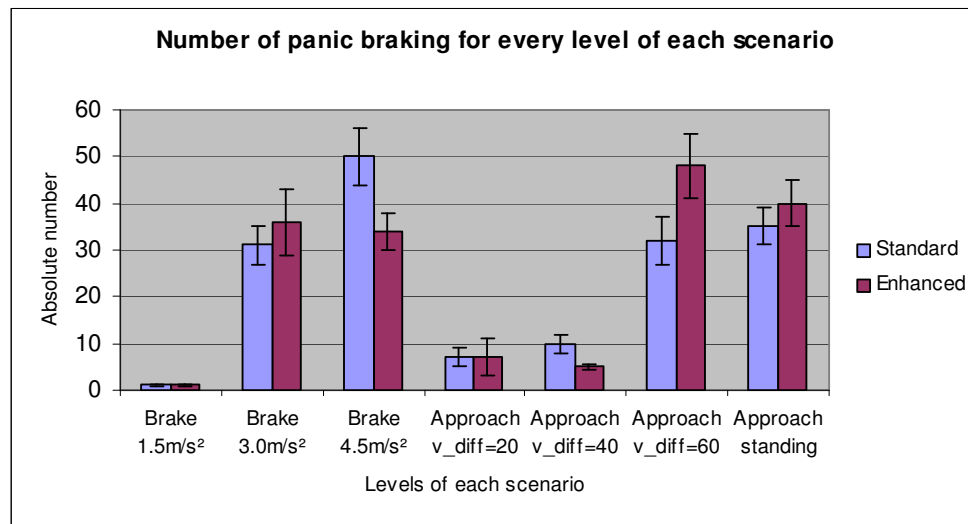

Figure 77. Number of panic braking situations for every level of each scenario

The comparison of panic braking between conditions shows that the total panic braking situations does not differ much between conditions. The total number of panic braking in the standard condition was 166 and the enhanced condition 171. The standard group had a reduced number of panic braking situations in the $v_diff = 60 \text{ km/h}$ level whereas the enhanced group had a reduced number of panic braking situations in the $v_diff = 40 \text{ km/h}$ level and in the $m/s^2 = -4.5$ level. At all other levels of the scenarios, differences between conditions were minimal. Figure 78 shows the mean and the standard deviations of the decelerations in panic braking situations for a more qualitative comparison.

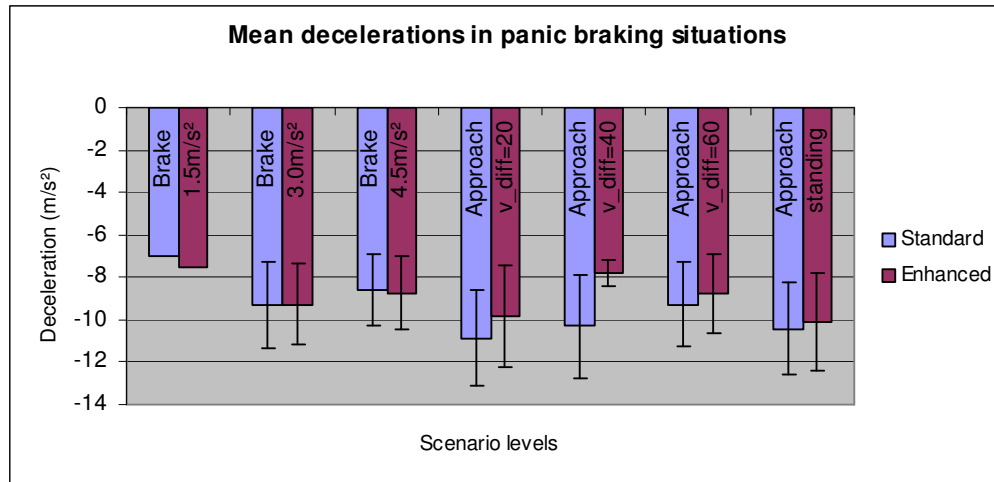

Figure 78. Mean decelerations of panic braking for every level of each scenario

Figure 78 shows that the deceleration levels of the panic braking situations are lower in all levels of the approach scenario in the enhanced group and very similar to the levels exhibited in the standard group at all levels of the braking lead vehicle scenario.

Driving performance

In terms of participants' overall driving performance, the total number of crashes, the number of lane departures and the standard deviation of the distance (m) to the road edge were analysed. In total, 17 crashes occurred over the entire experiment. Table 29 shows the levels of the scenarios at which these crashes occurred for both conditions.

Table 29. Total number of crashes in both groups in the entire experiment

	Standard group	Enhanced group
v_diff = 40km/h	2	0
v_diff = 60km/h	3	0
Standing vehicle	6	6

The number of lane departures was based on the number of times at least one wheel went over the side line. Table 30 shows the number of times this occurred per drive in each condition.

Table 30. Number of lane departures per drive in each group

	Standard group	Enhanced group
Drive 1	7	6
Drive 2	8	6
Drive 3	5	5

Total

20

17

The standard deviation of the distance (m) to the road edge was compared between driving with the ACC system in standard and enhanced conditions as well as during manual driving in all three drives. The results are shown in Figure 79. The effects of condition and drive number were not statistically significant.

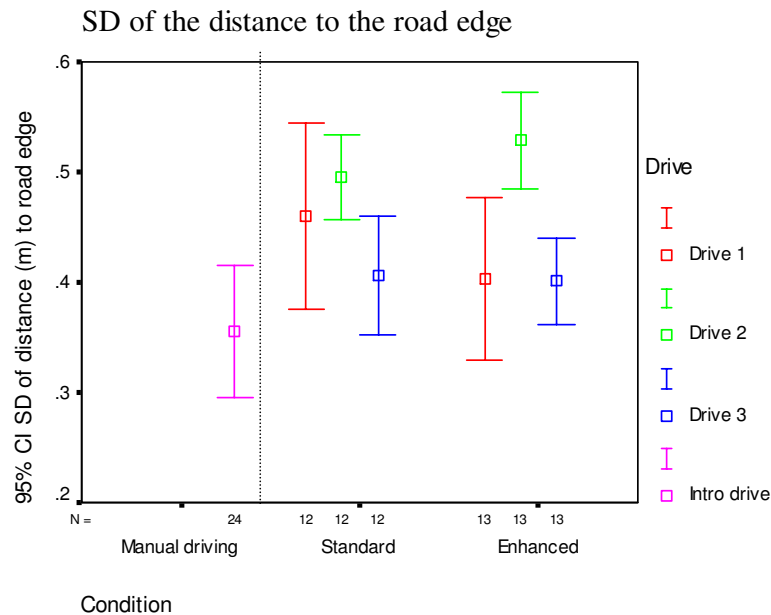

Figure 79. Standard deviation of road edge distance in both conditions and manual driving

Peripheral Detection Task (PDT)

Peripheral detection task was used to measure peaks in participants' workload as well as their ability to recover after these peaks. The stimulus was programmed to randomly appear imbedded in the driving scenery on the left side, on the right side or not at all. The stimuli was displayed 3 s after the onset of a scenario or just after the danger was over. A higher RT and a higher fraction of missed signals (number of missed stimuli divided by the total number of stimuli) is the result of higher workload. Figure 80 and Figure 81 show the mean hit rates and reaction times in each condition for every experimental drive. In the introduction drive, the PDT stimulus was not based upon the timing of the scenarios but appeared randomly, left or right, on average every 10 s, with a random variation of between 5 and 15 s.

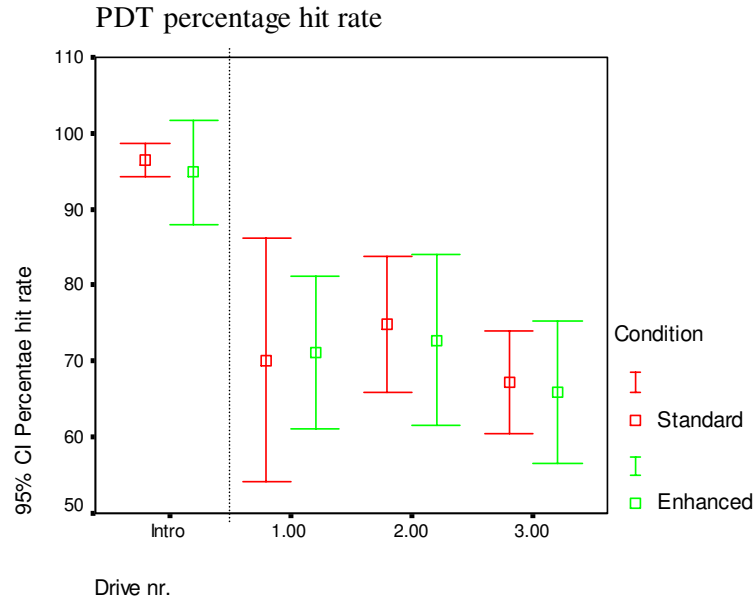

Figure 80. Percentage hit rate to the onset and recovery stimuli

Figure 80 shows a relatively low hit rate in both the standard and enhanced conditions in all three experimental drives. There was no significant main effect of display condition on the hit rate, $F(1,88) = 0,21$, $p = .64$, or of drive number, $F(2, 88) = 0,78$, $p = .37$. The Display \times Drive interaction was also not significant, $F(2, 88) = 0,75$, $p = .52$.

An analysis of the hit rate of the stimuli presented on the left and right sides showed that a considerable number of incorrect choice decisions had been made. Drivers, particularly for left-side stimuli, often activated the wrong indicator (see Figure 81). Incorrect reactions were below 10% in drive 1, 5% in drive 2 and 3% in the third drive for right-hand side stimuli in both conditions. The miss rate (total stimuli – hit rate), usually understood as consisting of signals that were not reacted to, is largely affected by the number of incorrect choice decisions. The high incorrect reactions, accounting to approximately 20% in the second and third drives and around 8% in the third drive must now be accounted for in the new calculation of the miss rate (total stimuli – hit rate – incorrect reactions).

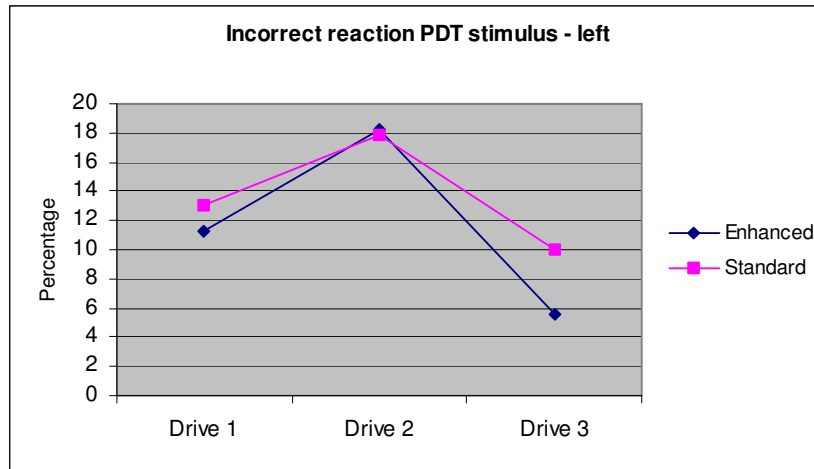

Figure 81. Incorrect reactions to the left PDT stimuli

Figure 82 shows participants' reaction times to the PDT stimuli. Both groups reaction times show a great deal of variance within each drive and a similar mean reaction time, around 1 s. There was no significant main effect of display condition on reaction times to the PDT stimuli, $F(1,81) = 0,15$, $p = .69$, or of drive number, $F(2, 81) = 1,25$, $p = .29$. The Display x Drive interaction was also not significant, $F(2, 81) = 0,48$, $p = .69$.

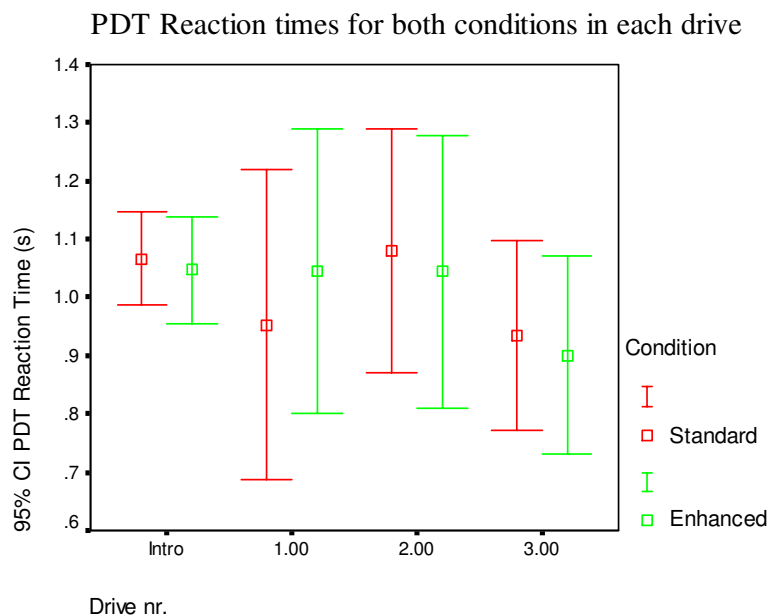

Figure 82. Mean reaction times to the onset and recovery stimuli

Figure 83 shows mean reaction times on the PDT task when the stimulus was presented at the onset of the scenario (scenario onset) and just after the potential danger was gone (recovery). Mean reaction times to the stimulus at scenario onset were quicker in the enhanced condition in every drive. The mean reaction times to the stimulus at recovery showed a similar trend in

the first two drives. There was a statistically significant main effect of display condition on drivers' reaction times to the onset stimulus, $F(1,50) = 31,94$, $p = .01$, with drivers in the enhanced display condition reacting faster to the stimulus than drivers in the enhanced display condition. There was also a significant main effect of drive number, with drivers in the standard condition having increased reaction times and thereby a higher relative difference, with little variance within conditions, to the reaction times of drivers in the enhanced condition, $F(2, 50) = 11,98$, $p = .01$. These main effects were qualified by the significant Display x Drive interaction, $F(2, 50) = 10,44$, $p = .01$.

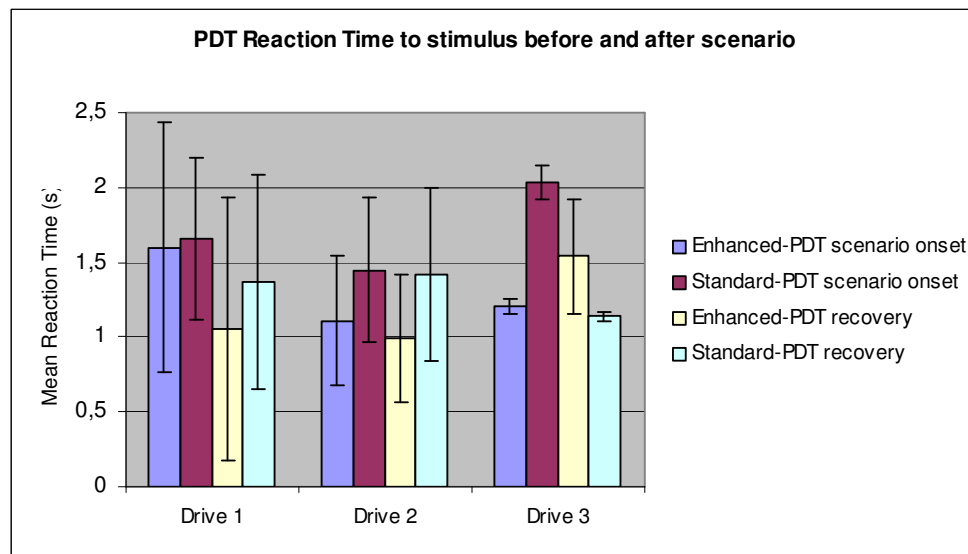

Figure 83. Comparison of mean reaction times to onset and recovery stimuli for each drive

Subjective evaluation

In terms of participants' subjective evaluations of both the displays, the questions administered after each experimental drive concentrated on perceived system understanding and system safety. The reported understanding of the system focused on their perceived ability to predict the need for intervention as well as the adequate braking force necessary upon intervention. In terms of perceived safety level, the questions focused on the perceived helpfulness of the displays with regard to holding a safe distance to preceding vehicles and offered support in helping the avoidance of collisions. The figures show subjects mean responses in each condition, after each drive. Answers were made on a 7-point Likert type scale. Figure 84 shows participants' responses to how much they thought the interface helped them to predict the need to take over control, while Figure 85 shows their reported ability to predict the necessary braking force upon intervention. Figure 86 shows participants' responses to how much they thought the display supported them in keeping a safe distance to the preceding vehicle and Figure 87 shows how much help the display provided to avoid a collision. The term 'display' implied both visual and acoustic feedback.

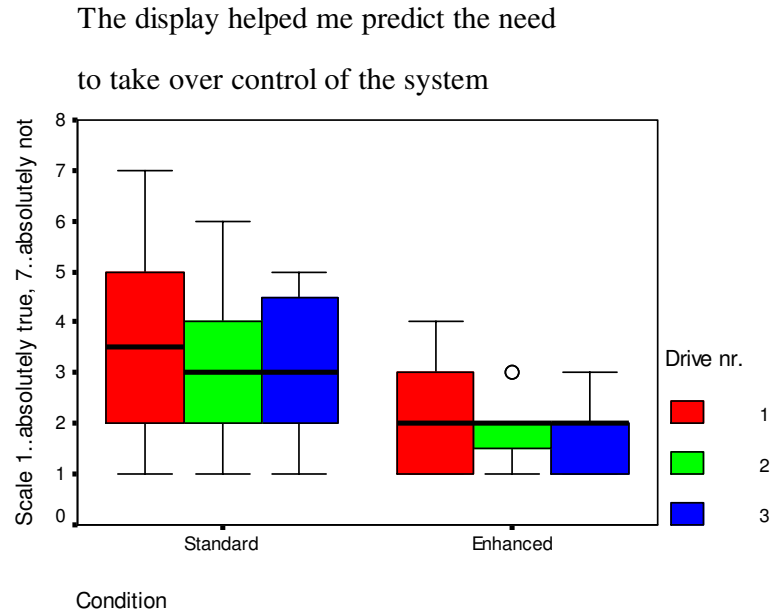

Figure 84. Participants' subjective ability to predict the need for intervention

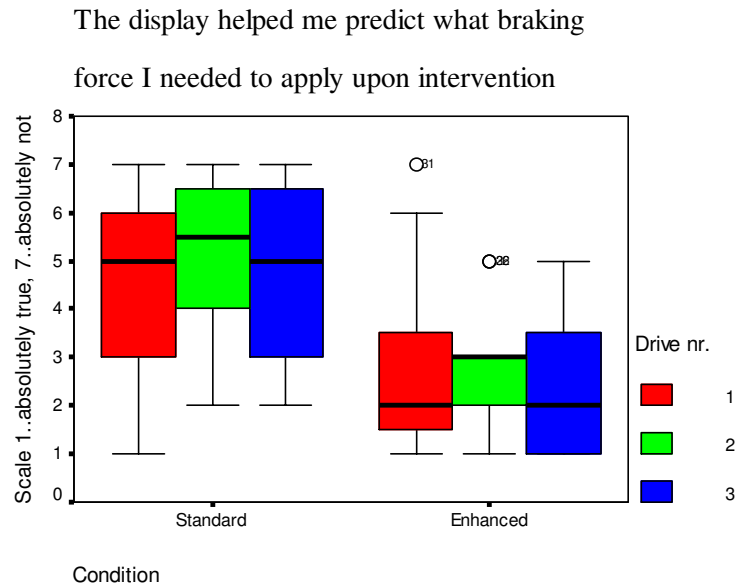

Figure 85. Participants' subjective ability to predict the necessary braking force upon intervention

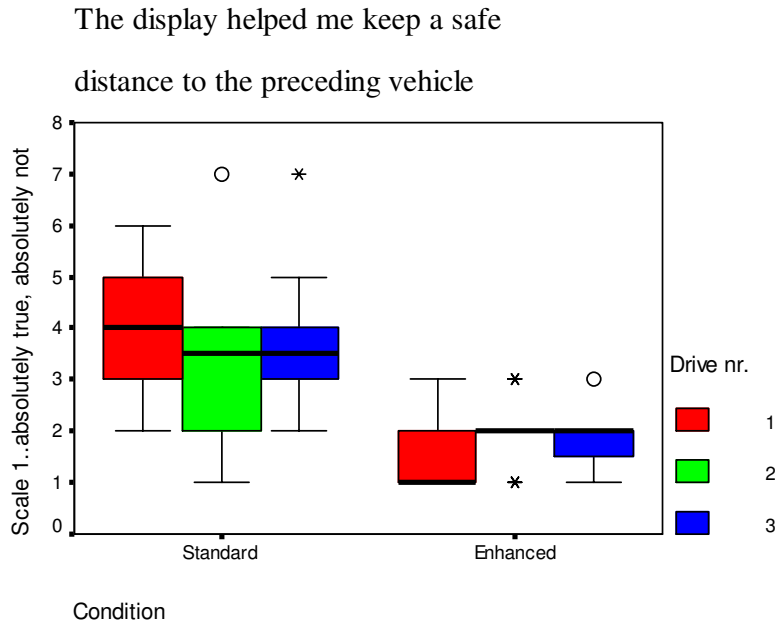

Figure 86. Participants' subjective impressions of the display's help in keeping a safe distance

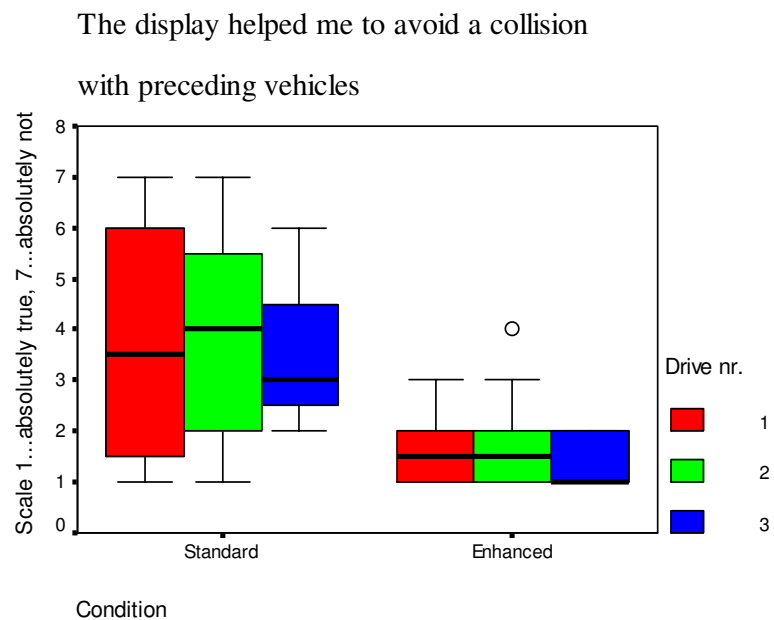

Figure 87. Participants' subjective impressions of the display's help to avoid a collision

Overall, the mean of the drivers' responses in the enhanced group, who drove with a personalised warning interface, indicate towards the tendency that the display (acoustic and visual) had helped them to learn when they needed to take over control of the system as well as the necessary braking force they needed to apply upon intervention. Drivers within the enhanced display condition also found that, on average, the display helped them to keep a safe distance to the lead vehicle and to avoid collisions (or near collisions). The participants'

answers show less variation in the enhanced group over all three drives, compared to the answers within the standard group. The mean of the drivers responses in the standard group show a central tendency that the display was not very helpful in learning to predict the need for intervention and had not helped at all in applying the appropriate braking force upon intervention (3 scale point difference on average over all drives). Participants in the standard group were unsure whether the display had helped them to maintain a safe distance or assisted them in avoiding collisions. A difference, in terms of the subjected rated scale points, of at least 2 and a half between groups, which remains constant over all three drives.

There was a statistically significant main effect of display condition on drivers' subjective ability to predict the need for intervention, $F(1,66) = 21,18$, $p = .01$, with drivers in the enhanced display condition holding the statement to be more true than drivers in the enhanced display condition. The main effect of display condition on drivers' subjective ability to predict the necessary braking force upon intervention was also significant, $F(1,66) = 24,28$, $p = .01$, with drivers in the enhanced display condition holding the statement to be more true than drivers in the enhanced display condition. The main effect of display condition on drivers' impressions of the help received in keeping a safe distance to the lead vehicle was also significant, $F(1,66) = 53,93$, $p = .01$, with drivers in the enhanced display condition holding the statement to be more true than drivers in the enhanced display condition. Further, the main effect of display condition on drivers' impressions of the help received in avoiding a collision with the lead vehicle was also significant, $F(1,66) = 38,11$, $p = .01$, with drivers in the enhanced display condition holding the statement to be more true than drivers in the enhanced display condition.

6.2.4 Discussion

The aim of this study was to establish whether a simplified, personally adjusted display could improve the driver's ability to predict the need for intervention in take-over situations. The study compared drivers' ability to predict the need to take over control of the system as well as the necessary braking force upon intervention, when using a standard warning interface and a personalised, two-step warning display. Drivers interaction with the system was measured between groups, for every level of each scenario over all three drives. The dependent variables consisted of measures to determine drivers' interaction with the system. They consisted of dynamic driving measures, measures from the ACC-sensor as well as measures extrapolated from the recorded data. Additionally, the Peripheral Detection Task (PDT) was used as a secondary task to measure peaks in drivers' workload and of their recovery. Post-drive questionnaires established the drivers subjective feelings.

Firstly, the results are summarised in terms of the interaction effects predicted in the introduction. Secondly, the impacts on the hypotheses are discussed.

At the time of intervention, the distance (m) and time-to-collision(s) to the lead vehicle were measured. Significant differences between conditions were found at the -3 m/s^2 level of the following scenario and at a relative speed difference of 60 km/h in the approach scenario only. This may be due to the fact that at these levels, drivers must interpret the situation and decide, often within a very short space of time, whether an intervention is necessary. At a difference velocity of 20 km/h or at a lead vehicle deceleration of $-1,5 \text{ m/s}^2$, for example, the approach to the lead vehicle is comparatively slow, through the display drivers have time to notice early that the ACC system is regulating the distance, therefore these levels do not require much interpretation. Similarly, at the highest deceleration level ($-4,5 \text{ m/s}^2$), the situation does not require much interpretation due to its criticality. This level often causes an immediate reflex brake reaction, regardless of the warning system.

Thus, differences between conditions are most pronounced at the most learn-intensive levels of the scenarios.

Noteworthy in this analysis, is the steady learning progression in the standard condition, during the approach scenario. With the mean TTC at intervention remaining relatively constant over all three drives in the enhanced condition, the progression in the standard condition reduced the 3 s difference in TTC in drive 1 between both conditions, to 2 s in the second drive and to 1 s in the final 'learning test' drive.

No clear learning curve could be deduced in the breaking lead vehicle scenario. Within the standard condition, however, TTC was consistently higher in all drives compared to the enhanced condition. Similarly to the results seen in the approach scenario, TTC in the standard group only approached the entrance level TTC of the enhanced group during the final 'learning test' drive. Interestingly, mean TTC at intervention in the enhanced group did not vary between scenarios, remaining at approximately 4 s.

In terms of distance (m) at intervention, differences between both conditions support the TTC measures at intervention. The results from the distance at intervention analysis add additional information about the exact distance to the lead vehicle, however, measures of TTC remain the preferred measurement for comparing participants' understanding of the system limits and of their ability to predict the need for intervention for it is much more reliable, as it takes account of the vehicles' speed and accelerations.

Although no experimental hypothesis was formulated for TTC at intervention, the results clearly suggest a later braking reaction and thus a much closer approach to the lead vehicle within the enhanced group, which is not consistent with the experimental hypothesis formulated for minTTC.

Consistent with the results of TTC at intervention, minTTC presented significant differences between conditions at level $\text{m/s}^2 = -3$ of the following scenario and $v_{\text{diff}} = 60 \text{ km/h}$ of the

approach scenario. At these levels of the scenarios, participants of the enhanced group had considerably lower mean minTTC values. The mean minTTC values of the standard group follow a downward trend, reaching mean values close to the enhanced group in the last drive. In the enhanced condition, at level $m/s^2 = -3$ of the following scenario, the mean minTTC drops to the lowest level during the final drive (2.5 s). This downward trend is of concern, especially if minTTC values drop below 2.0 s, a value which is regarded as the lower boundary of safe TTC (Rekersbrink, 1994).

The standard distribution of minTTC showed, however, that in more than three-quarters of all events, minTTC remained above 2.0 s. Measures of minTres (s) and minimum distance (m) followed similar trends to minTTC and presented no significant differences at any other level. The experimental hypothesis formulated in the introduction was that the minimum TTC value would be greater in the enhanced condition compared to the standard condition. At the most learn-intensive levels, however, when active interpretation and decision making is required, the results are not consistent with this hypothesis. In these situations, as the results from TTC at intervention suggested, the results showed the reverse effect: $TTC \min_{enh} < TTC \min_{sta}$.

Higher minTTC values suggest a delayed braking reaction time. The results of participants' reaction times (reaction time from the actuated brake light of the lead vehicle to brake pedal activation) in the car-follow scenario presented a significant difference between both groups in the display condition at the $m/s^2 = -3$ level. At this level, a mean difference of over 1 s in drivers' reaction times was measured in the first and second drives. The mean reaction times in both conditions are closer in the third drive although the enhanced group maintain a comparatively slower reaction time. At the scenario level $m/s^2 = -4,5$, reaction times are overall faster (between 2 s and 2.5 s), and the mean reaction times in the standard group are similar to the enhanced group, no significant difference is found between conditions at this level, largely due to its criticality. At the lowest deceleration level $m/s^2 = -1,5$, too few reactions were recorded to make any significant comparisons between both groups. More braking reactions were recorded, however, in the standard group. The results are not consistent with the formulated hypothesis but show consistency with the minTTC results. In situations requiring interpretation, drivers in the enhanced condition waited longer before intervening, letting the ACC system start to decelerate before making their decision on the necessity to intervene. This behaviour tended to lead to closer approaches to the lead vehicles and resulted in a smaller TTC.

Another important measure of drivers' ability to predict the need for intervention in take-over situations and the acquirement of skill in taking over control of the ACC system over time is participants' maximum deceleration rates. Maximum deceleration rates are often the result of a sudden, surprise reaction or 'panic braking'. Panic braking was defined as a deceleration

equal to or greater than the mean maximum personal deceleration of the drivers' respective group. The results showed no significant differences in the number of panic braking situations between both groups at any level of the independent variable (scenario type). The overall number of panic braking in the standard and enhanced conditions was practically the same. The analysis of the mean and standard deviations of the decelerations in panic braking situations showed that these were lower at all levels of the approach scenario (including during approaches to a standing vehicle) in the enhanced condition, while at all levels of the following scenario, mean deceleration levels were similar in both conditions.

Based upon participants' maximum deceleration rates, it was possible to determine their braking adequacy in proportion to the level of deceleration applied by the lead vehicle. The smaller the difference between the deceleration of the lead vehicle and participants' deceleration, the more adequate the rate of deceleration is. The experimental hypothesis was that deceleration rates would be more adequate in the enhanced display condition, compared to the standard display condition, or that $A_{ad} - A_{enh} < A_{ad} - A_{adsta}$. At $v_diff = 40$ km/h, mean decelerations in the standard group is higher than in the enhanced group in every drive. This relative difference in speed is close to the ACC deceleration limit but can still be handled alone by the system, without need for intervention. After the first drive, no more interventions were recorded in the enhanced group. In the standard group, however, despite a reduction in the number of interventions and an increase in the rate of adequate braking, drivers did not learn that no intervention was necessary at this level. In the following scenario, at level $m/s^2 = -1,5$, both conditions learned that no deceleration was necessary, thus adequate, the number of driver decelerations were too few to conduct a significance test. When the lead vehicle decelerated with a force of $m/s^2 = -3$, drivers' decelerations were considerably higher in both groups although the enhanced groups showed a tendency towards more adequate decelerations in every drive. This trend was further supported when the lead vehicle deceleration rate was $-4,5$ m/s^2 . At this level of the scenario, the effect of the display condition was statistically significant.

The results showed support for the hypothesis, drivers in the enhanced group learned the necessary, or adequate, braking force necessary to be applied during take-over situations faster than the drivers in the standard group. Whether they also learned to intervene when it was really necessary, was analysed using the outcomes of the signal detection theory.

Intervention necessity was analysed in terms of four classes of joint events, based on the combination of two states of the world (necessity to intervene or not) and two response categories (intervention or no intervention). The four outcomes are labelled: hits, misses, false alarms and correct rejections.

The necessity of driver interventions in both conditions showed similarities in both scenarios. At the highest deceleration and difference velocity, drivers in both groups reached high levels of hit rates (intervening when necessary). At the smallest deceleration and difference velocity, participants in both groups correctly left the system to decelerate (correct rejection) the vast majority of the time, although a slightly higher rate of false alarms were (unnecessary intervention) resulted in the standard condition.

At the intermediate lead vehicle deceleration level ($-3,0 \text{ m/s}^2$), slightly more hits were recorded in the enhanced group than in the standard group. At the intermediate difference velocity rate of 40 km/h, however, where the deceleration of the ACC system can still prevent a collision, although it sometimes leads to a very close approach to the lead vehicle, considerably more correct reactions were recorded in the enhanced condition. The low number of correct rejections in the standard condition was reflected in the high number of false alarms in this condition (unnecessary intervention). The rate of false alarms in the standard condition was almost 40% compared to just over 10% in the enhanced condition.

Overall, the results showed a tendency towards the original predictions: that drivers in the enhanced display condition would have made less false alarms and more correct rejections. No significant difference was found, however, between the conditions and more research would need to be conducted in order to confirm this trend.

The Peripheral Detection Task (PDT) was used to measure peaks in participants' workload as well as their ability to recover after these peaks. A higher RT and a higher fraction of missed signals (number of missed stimuli divided by the total number of stimuli) were interpreted as the result of higher workload. The results of the hit rate was not significant between conditions. Relatively low hit rates in both standard and enhanced conditions were partly attributable to the considerable number of incorrect choice reactions i.e. the wrong indicator was used to cancel the left or right-side stimuli. The results of participants' reaction times to the PDT showed a significant difference in stimulus reaction times at scenario onset and during scenario recovery between both conditions. The quicker reaction times in the enhanced condition suggests that during take-over situations, drivers' workload, or the peaks in workload, that are typical in this type of driving situation were significantly reduced as well as the ability for drivers to recover immediately after the potential danger.

The comparison of participants' subjective feelings from their ratings on the questionnaire scales, provided a clear central tendency in terms of system understanding, feelings of safety, predicting when to regain control as well as the sensitivity required upon intervention. In terms of safety feelings, drivers in the enhanced group also absolutely agreed that the display had helped them avoid a collision and somewhat agreed that it had assisted them in keeping a safe distance to the lead vehicle. Drivers' responses in the standard group showed

considerably more variation within drives. In terms of understanding the system, drivers felt unsure whether the display had helped them to learn when to intervene and disagreed completely with the statement that the display had helped them in applying the appropriate force upon intervention. Further, drivers' responses in the standard group showed that drivers were indecisive as to whether the display had helped them to avoid potential collisions and completely disagreed with the statement that the display assisted them in keeping a safe distance to the lead vehicle. In terms of learning when to take over control of the system as well as the necessary braking force to apply upon intervention, drivers responses in the enhanced group showed little variation within each drive or over time. The difference in the mean ratings showed clear differences between groups, especially in predicting the force that needed to be applied. Drivers in the enhanced group felt absolutely sure that the display (acoustic and visual) had helped them learn when as well as how to intervene.

Most of the interaction effects were confirmed, a closer look is now taken at the predicted interaction effects that were not confirmed from the results before discussing their impacts on the hypotheses formulated in the introduction.

TTC min and *Tres* min were predicted to be higher in the enhanced group compared to the standard group. It was assumed that drivers would intervene sooner, in order to keep a greater, and thus safer, distance to the lead vehicle. Similarly, it was predicted that drivers' reaction times would be faster in the enhanced group i.e. time to brake pedal activation from the onset of the lead vehicle braking light would be shorter in the enhanced group. Following this idea, it was also predicted that Distance Error i.e. the difference between the distance at the beginning of the scenario and at the end, would be smaller in the enhanced group. The interaction effect between both groups on these measures, however, showed exactly the opposite: drivers in the enhanced group showed smaller *TTC* min, longer reaction times and a larger Distance Error compared to the standard group. In other words, drivers waited longer before decelerating, letting the system take over as much of the braking task as possible. This increase in delayed reactions and the consequent closer approach to the lead vehicle may not at first sight seem like a desired effect, possibly increasing the risk of collision. The results, however, showed a tendency towards less collisions in the enhanced group. In the approach scenario, two crashes occurred at a difference velocity of 40 km/h and three crashes occurred at a difference velocity of 60km/h in the standard group, whereas, no collision was recorded in the enhanced condition. Thus, although approaches were closer, less near collisions were recorded and no accidents were recorded in the enhanced group. Drivers seemed to voluntarily let the ACC system do most of the braking until it was necessary for them to intervene. In terms of subjective feelings of safety during use of the system, significantly higher ratings were reported in the enhanced group. Longer reaction times and nearer

approaches did not negatively affect overall driving safety, the implications of it on drivers' learning to predict the system's limits are now considered.

An analysis of the number of misses and false alarms can give us an insight into this effect. It was predicted that the number of misses and false alarms would be lower in the enhanced group. The predicted effect was held to be true. A lower number of false alarms was shown for all the levels of the scenarios which do not always require driver intervention. It can be concluded that interventions in the enhanced group were not only delayed compared to the interventions in the standard group but also more accurate. The further two interaction effects regarding drivers' interventions were regarding drivers' applied braking force upon intervention. It was predicted that drivers in the enhanced group would exhibit less surprise braking reactions with high deceleration levels i.e. exhibit less panic braking than the standard group and apply a braking force proportional to the scenario level i.e. exhibit more adequate braking. The results supported the predicted interaction effects.. Measures of panic braking and adequate braking showed that drivers in the enhanced group made less abrupt braking manoeuvres and applied more adequate force upon intervention compared to the standard group. The adjusted interaction effects for minimum TTC, reaction time and distance error can be summarised as follows: $TTC_{min_{enh}} > TTC_{min_{sta}}$, $RT_{enh} < RT_{sta}$ and $DE_{enh} < DE_{sta}$.

The impact of the adjusted interaction effects on the hypotheses is now considered. Firstly, it was hypothesised that the response criterion is dependent not only on learning i.e. getting used to the system and being more comfortable with predicting the systems' behaviour over time, but also on an individual 'threshold', based upon an internal reference which can be adjusted, especially in the learning phase, by targeted information. The results are consistent with the first experimental hypothesis: drivers' threshold in take-over situations was significantly changed i.e. the response criterion of drivers learning to use the ACC system with the enhanced interface was significantly delayed at the most learn-intensive levels of the scenarios. Perhaps the most obvious explanation for this finding is an increase in drivers' trust in the system. Muir & Morray (1996) found a high positive correlation between trust and the use of automation. The subjective impressions of the degree to which the system could handle take-over situations reliably, safely, and effectively was much higher in the enhanced group.

Increased trust levels have been found to encourage behavioural adaptation towards later braking i.e. later interventions and riskier driving styles. Similarly, headway distances were found to decrease with the use of warning systems as trust in the system grows and the hazard of collision is removed (Lee, 1999). In the enhanced condition, drivers were able to retrieve the necessary information regarding the situations' criticality from the visual displays. Acoustically, a person-centred warning was emitted, signalling their personal approach, or deceleration force 'threshold', instead of a system-centred warning which gave an indication of the system status. Drivers in the enhanced group could further rely on the safety of an

alarm signal, which will prevent a collision as long as the brakes are immediately applied. Drivers were thus able to incorporate the system into their personal driving style through appropriate use of warning modality, the personalisation of the display as well as the stepwise warning information. Participants were randomly allocated to conditions, thus lessening the likelihood of there being differences between the groups such as in 'tail-gating' tendency, usually indicative of a sportier, more aggressive driving style.

In terms of safety, longer reaction times meant smaller minimum TTC values in the enhanced group. The mean minimum TTC values are the lowest at the most learn-intensive levels of the scenarios. The minimum TTC was equal or above 2.0 s in more than three-quarters of all events a value which has often been regarded as the lower boundary of safe TTC (Rekersbrink, 1994). Situations in which drivers intervened when $TTC < 2.0$ s might present situations that drivers inadvertently got into, thus presenting a particular danger. The results from the questionnaire, however, would tend to refute this idea. Drivers stated that they felt safer when driving with the enhanced interface and that it had helped them keep a safe distance to the lead vehicle. A possible explanation is that participants' threshold levels of tolerance to close headways may have been higher than if they were driving on the road as the danger factor was less present (see section 4.2).

An alternative explanation is that participants' experienced intrinsic risk in the enhanced condition was reduced. In line with the risk handling theories, it can be expected that, to the extent ADAS are perceived as a safety benefit, they may effect a reduction in the perception of driving risk when using the system (Ward, 1996). In accordance with the tenets of the risk homeostasis theory, this perceived reduction may precipitate a higher risk driving style through later braking times and shorter headways. The findings of the study are thus consistent with those of Hoyes et al. (1996), Stanton & Pinto (2000) and Wilde (1994). Participants seemed to adapt new driving behaviour to attain the same level of target risk as in the standard group. The response threshold in take over situations in the enhanced group was extended by the two-stage personalised warning system as the intrinsic risk experienced by the driver in these situations was reduced.

The second hypothesis predicted that feedback timing is more crucial than feedback specificity in situations demanding rapid decision-making and response times. Drivers' procedural knowledge and performance, as measured by the number of safer reaction times (less near misses and increased distances) and correct responses (appropriate braking force and intervention rates) will be markedly higher for drivers in the enhanced group.

Participants in the enhanced condition produced less collisions and near misses, however, the distances upon intervention were significantly smaller compared to participants in the standard condition. Nonetheless, drivers' behaviour showed support for the hypothesis as

drivers in the enhanced condition were able to predict the need for intervention as well as the appropriate necessary braking force significantly better and faster compared to drivers who learned to use the system with the standard interface.

The results are an indication of the advantage of using a time measure for the emittance of warnings. The system oriented warning in the standard display informs the driver based on the maximum deceleration of the system and prediction that more deceleration is necessary or on the distance to the lead vehicle which is too small for the activation of a potentially necessary braking force, which, in the instance the threshold is exceeded – emits a gong although no interaction is needed. Further, the occurrence of the warning, independently of the situation, is dependent on the actual driven speed. At low speeds, the deceleration of the system is small, while at higher speeds, the deceleration capabilities of the system are set higher (Prestl et al., 2000). The drivers' decision making task and ability to predict the need to intervention is thus made more complicated. Warning algorithms based on deceleration alone seemed to cause understanding and learning problems, consequently conducting to the sub-optimal interaction observed in the standard display group.

The advantage of warnings based on a time algorithm is that they can react immediately to the danger avoidance action taken by the driver (e.g. deceleration manoeuvre). These actions that have a direct influence on the situational parameters and on the calculation of the time until the necessary action is needed (time reserve), are directly incorporated into the timing of the warning. Moreover, it allows for driver performance i.e. reaction time or personal preference, i.e. rate of deceleration, to be integrated in the warning algorithm e.g. reaction time.

The two steps of the warning allowed to resolve the trade-off between alert intrusiveness and early warning. In the first stage, the visual looming display enabled a situation- and driver-specific analogue warning of the actual danger level. By means of a warning gong, emitted when the warning deceleration exceeds the maximum deceleration the driver could learn the maximum braking capacity of the ACC system, thereby increasing the number of correct rejections and decreasing the number of false alarms. At the second stage, the driver received an alarm signal simultaneously with the 'crash symbol' which alerted him/her to the need to take-over and of the required braking force. The second stage increased the number of hits and decreased the number of misses as well as 'panic braking' reactions.

The third hypothesis was related to participants' workload. It was predicted that the participants allocated to the enhanced group would have reduced peak workload levels and workload is predicted to decrease more rapidly (recovery) following critical and semi-critical situations.

Sudden increases in workload were measured during the interaction of the driver with the ACC system. Although the system does not require the driver to look inside the vehicle on a display in order to use the system, take-over situations place a high demand on the driver as the system provides information to the driver e.g. warning and will perform actions that the

driver did not expect or initiate, in which, particularly in the learning phase, the driver might look at the display for additional information. Most of the workload or distraction concerns short-lasting peaks that are often difficult to detect with the traditional methods for measuring workload. The sudden increases in workload, that often represent short but high peaks are potentially dangerous because they cannot be predicted and anticipated. While driving, workload caused by a ADAS is added to the workload induced by the primary driving task. The Peripheral Detection Task (PDT) is a very sensitive method of measuring peaks in workload induced by a critical scenario (Baumann et al., 2003; Martens & van Winsum, 2000; Olsson & Burns, 2000).

The PDT hit rate measures revealed no significant difference between conditions. Hit rates showed that a considerable number of incorrect choice reactions had been made e.g. tapping the right indicator for a signal displayed on the left hand side. These events of incorrect choice reactions were overall lower in the enhanced condition and decreased in both groups over time (to respectively 3% and 8% of total reactions for right and left hand side stimuli). This trend indicates the high workload in take-over situations but also seems to indicate the problem drivers experienced in adjusting their behaviour to use the indicator for these events. In terms of reaction times, no overall significant difference was found between conditions. A significant difference was found, however, between conditions for stimulus reaction times at the onset and during recovery of take-over situations. Therefore, the results together indicate that less resources needed to be allocated in the enhanced group in critical and semi-critical situations and workload peaks decreased more rapidly (faster recovery).

With regards to learning of the system, this result supports the previous hypotheses. Drivers learning progression was much faster in the enhanced group as demonstrated by the higher number of correctly repeated procedures and the accuracy of each repetition. These comparative improvements in the enhanced condition indicated increased learning which can also be described as an increase in ease in predicting the need to reclaim control and executing the take-over task appropriately. From this 'easiness' - presented as a decrease in resources needed to execute the task - the possibility to perform additional tasks beside the learned task increased.

The stimulus that was used was the same (a red square presented) and it was presented at the same horizontal and vertical angle in the scenery as in the studies of Baumann et al. (2003), Martens & van Winsum (2000) and Olsson & Burns (2000). The tasks required little conscious attention and could be performed without turning the head in the direction of the stimulus. However, the differences in PDT reaction times in this study were likely to be affected by two factors. Firstly, the type of PDT reaction used in the previous studies were simple reaction times, whereas the reactions in this study were choice reaction times. Drivers had to choose which signal was present (left or right), and then make the response appropriate for that stimulus (tap the left or right indicator). This requires two processes not present in

simple reaction time: 1) signal discrimination i.e. deciding which signal occurred and 2) response selection i.e. choose the response based on which signal occurred. These extra mental operations slow down reaction times. The relationship between RT and the number of alternatives is non-linear, thus doubling the number of alternatives does not increase RT by a factor of two but rather by the log of the number of possible signals. In Martens & Van Winsum's (2000) simulator study in which critical incidents unexpectedly took place on the motorway, drivers' reaction times to a braking lead vehicle incident was 0.85 s, compared to a reference value of 0.65 s (driving on a straight road at 80 km/h). The considerably higher reaction times in this study (between 1 and 1,5 s) were partly due to the choice decision reaction but secondly, to the actual method of response. In the previous studies, participants were required to respond by pressing a microswitch that was attached to the index finger of the dominant hand, whereas in this study, drivers were asked to respond by a brief tap of the indicator lever (right or left). The extra movement that this response entails and the unlearning of using the indicator to respond to the PDT task rather than to indicate, could account for the extra reaction time as well as for the number of misses or incorrect choice reactions. In their simulator study, Martens & Van Winsum (2000) found that in the lead braking vehicle scenario, the fraction of missed signals was five times as high as the reference value. Overall, therefore, although the differences in reaction times differ, the functional meaning of using the indicator or the choice reaction for drivers' responses to the PDT did not seem to affect the task's ability to detect peaks and variations in workload between conditions.

Towards the application of the system in the vehicle, under real circumstances, the difficulty for real sensor systems to anticipate the driving environment and completely remove the incidence of false alarms (generated when there is no danger), or the absence of alarms (not generated when there is a danger) needs to be addressed. The use of warning systems is heavily related to driver's trusts of the warnings (Muir & Morray, 1996), and acceptance and behavioural adaptation to the system is largely attributed to the accuracy of warnings (and to the annoyance of false warnings), it is necessary to evaluate the warning system in the field, to validate the effectiveness of the hypotheses of the proposed warning interface. The simulator is however, an ideal instrument towards testing warning concepts as the situational parameters can be held constant and the accuracy and timing of warnings faultless.

Further issues in light of the integration into a vehicle, include the ascertainment of drivers performance and preference values. In the simulator, this was realised in an individualisation drive in which five hard, abrupt decelerations, forcing participants to a braking reaction, were carried out in order to identify the maximum preferred level of driver-specific decelerations. In the field, the system would need a certain period of on-line learning time before the driver's behaviour can be extracted (Onken et al., 2001; Von Garrel, 2003)

and the values can be assigned to the driver with relative confidence and integrated into the warning algorithm for his/ her personalised warning.

There are a number of additional considerations on top of the question of quantitative assessment of warning system algorithms for ACC. Should the focus be specific to learning to drive with ACC or should the data also be collected when the ACC system is switched off, for a more general protective approach, in which a personalised warning could be emitted for ACC and manual driving. With the integration of future longitudinal and lateral ADAS systems, sensor information could also be used to inform drivers when systems are deactivated. Driving behaviour could then be more unified across situations and the change between manual and assisted driving would be less marked. Long-term field evaluations would need to be conducted to empirically determine behavioural modification from ADAS warnings as the level of usage from combinations of ADAS systems increases. Further, the development and integration of assistance, detection and avoidance systems for different driving circumstances e.g. side impact, poses a serious challenge to the need to provide effective and timely warning information to the driver.

7 CONCLUSION

Central to the presented experimental studies was to find out how embedded support systems could improve interactions within the human-ACC-environment system during the learning phase. So far, empirical studies on driving with an ACC system have reported high acceptance levels of the system and an increase in driver comfort (Brook-Carter et al., 2002; Fancher & Ervin, 1998; Hogema & Janssen, 1996; Törnros et al., 2002). Most theories of automation, however, warn of the dangers of automating tasks that were previously manual (Hancock & Parasuraman, 2003; Parasuraman, 2000; Parasuraman & Riley, 1997; Sheridan & Parasuraman, 2000) and of changing the drivers' task to a supervisory one (Becker et al., 1994; Chaloupka et al., 1998; De Ward et al., 1999; Risser & Lehner, 1997; Stanton et al., 1997; Stanton & Young, 1998; Törnros et al., 2002).

A long-term field study analysis was undertaken to uncover the main learning hurdles associated with learning to drive with an ACC system and the parameters for their assessment. A further aim of the study was to assess the extent of the encountered difficulties and define a set of learning aims, upon which drivers' performance and learning stage could be measured.

The results of the analysis uncovered weaknesses related to the operation of the system and use in varying environmental conditions as well as difficulties in situations where the ACC system reached its limits. In terms of system limits, the analysis of take-over situations demonstrated the high frequency of their occurrence and the correspondingly high number of associated 'panic braking' reactions. Overall, results showed a long and sometimes critical learning phase.

The learning curve was characteristic of learning curves for complex skills (Roessingh & Hilburn, 2000). The results show that the time span, largely dependent on the gathering of sufficient experience necessary to reach expertise, is considerably shorter when considering the operational and functional elements of the system compared to the situation specific limits of the system. In other words, the motor elements of driving with an ACC were learned considerably faster than the cognitive, decision making tasks.

The learning of more complex tasks, such as reclaiming control of the ACC system in situations when the system limits were reached seemed to show support for Anderson's (1993) stages of learning. However, as some drivers were already beginning to show the proceduralisation of learned rules within the first half of total driven kilometres, others seemed to not yet have gained a repertoire of condition-action rules sufficient to progress from the cognitive level. Differences in learning were observed in participants' strategies. While some drivers managed to integrate the system into their own driving style, others were

seemingly still evaluating the system to find the optimum subjective use. Highly individual learning curves were due to the adoption and adaptive use of different strategies. Strategy changes, or strategy shifts, frequently occurred at different times during practice for different participants. These findings support the literature and the growing evidence that strategy shifts play an important role in cognitive skill acquisition (Delaney et al., 1998; Rickard, 1999).

The results of the analysis enabled the identification of generalisable learning aims for the use of ADAS and an objective classification of four information categories representing the dimensions of interaction with the system for which learning must be effectuated. Based upon observable behaviours from drivers' apprenticeship of the ACC system, the results suggested that the success of learning and achieving might depend on having gained sufficient explicit knowledge in the early cognitive phase. It was concluded that system interactions would benefit from giving drivers explicit knowledge of the system through adequate feedback. This solution was implicit to the arguments put forth by Norman (1990a), Reason (1992) and Senders & Moray (1991) of re-integrating drivers into the control loop, and the previously mentioned work of Anderson et al. (2001) and Groeger (1997) who demonstrated that feedback is a crucial factor in the early stages of skill acquisition and essential for the learning of complex skills.

Implications for conceptualising novel displays to promote, particularly in the early phase, shorter learning times, effective operation and safer handling were tested in a simulator study. It was hypothesised that by adapting the information to drivers' experience, and responding to the difficulties met by users in the actual situation through adequate feedback, drivers' learning progress could be accelerated and the number of safety critical incidents could be reduced.

The intelligent tutoring gave feedback to drivers based on the cognitive apprenticeship learning framework (Cognition and Technology Group at Vanderbilt, 1993). This proved not to be a matter of course in the way in which people learn, but an effective method for not only attributing the appropriate amount of feedback according to drivers' learning stage but also an effective way to help drivers within the learning context.

Explicit acoustic feedback based on speech outputs enabled drivers to gain an understanding of the functional principles and of the operation of the system from a very early stage. Contrary to the concerns expressed of self-regulation in open learning environments (Groeger, 1997; Guerin, 1994; Kröner, 2001; Süß, 1996), drivers' interactions with the tutor system showed that drivers did not overestimate their levels of skill, mostly disregarding feedback once learning was accomplished.

The results show a positive tendency for the tutor system, not only at the operational level e.g. less errors and more efficient operation of the controls but also at the strategical level e.g. in

poor visibility. Learning of motor skills and understanding of the system's functional principles seemed to be well fitted to this type of adaptation.

At the tactical level, situated, anchored feedback enabled drivers to learn in context. In situations demanding drivers to reclaim control of the system, a-priori knowledge that the system limits may be reached and reactive feedback of the drivers' reactions enabled the correct rules to be applied more quickly. Understanding of sensor and controller behaviour and limits was demonstrated by drivers' ability towards better predictions of these situations, as measured by the reduction in unnecessary interventions and reduced number of panic reactions and supported by drivers' subjective evaluations. Significant differences were found between the experimental groups' subjective understanding of the system and in participants' ability to predict when to reclaim control of the system, however, relatively high levels of panic braking could still be observed in both groups. It was assumed that although the quick acquisition of explicit cognitive knowledge and type and timing of feedback helped drivers form the appropriate rules in the decision-making task and enabled an acceleration of the learning progress, take-over situations represent special conditions, in which influencing factors may have prevented a satisfactory fulfilment of the learning goal. For example, reaction times may have been influenced by the so called refractory period (Wickens, 1992). A dangerous traffic situation coupled with learning feedback may result in attention overload and delay in reaction, which would have necessitated a higher braking rate to avoid a collision.

The process showed support for Anderson's (1993) stages, from cognitive acquisition of knowledge to the proceduralisation of acquired rules. The results of the study, showed that explicit individualised advice plays a crucial role in helping drivers to update their mental models of the system while learning to drive with ACC. In the development of learn-adaptive support systems, however, consideration of learning stages should further help to establish drivers' learning needs as well as the design of appropriate feedback.

Overall, through an online adaptation with feed-back control, the feedback from the learn-adaptive, multimodal tutor system helped increase the speed of the learning process, towards the acquisition of skill.

Embedded intelligent tutoring for learning to drive with ADAS is definitely the high road for improving driver performance through closed-loop control of the learning task. However, making system information explicit during the early stages of interaction, is a solution that might not be the most adapted for all users, as was demonstrated by the systematic disregarding of functional and operational explanations by a participant with a highly technical background. Adequate feedback (Norman, 1990a) thus also seems dependent on individual attitudes. Moreover, at this stage especially, too much feedback may increase drivers' workload (Fairclough et al., 1993; Stanton & Young, 2000). Beyond the prioritisation of

information from the tutor system, therefore, the tutor would need to receive physiological and / or behavioural information of the driver in order to recognise situations in which situational demands are high, to adjust its response and feedback in accordance.

All dimensions at which learning must be effectuated were addressed by the tutor system. The most learn-intensive and simultaneously most critical aspect of learning to drive with the system, is reclaiming control. This aspect was more closely analysed in the second simulator study. Two aspects of reclaiming control of the system were addressed. The ability to predict the need to reclaim control and the appropriate sensitivity of response in take-over situations. It was predicted that in these situations, drivers' response criterion was not only dependent on learning i.e. getting used to the system and being more comfortable with predicting the systems behaviour over time, but also on an individual threshold', based upon an internal reference which can be adjusted, especially in the learning phase, by targeted information.

Adapted feedback on drivers' reference for comfortable decelerations and subjective risk proved a promising approach. Macro-adaptation (Leutner, 2003), informed drivers through a gradual warning of the moment in which their preferred deceleration level would be exceeded in order to follow the lead vehicle with a preferred headway—two driver-selected measures which are intuitive, assumed to be relatively constant and, if impinged on, will directly be noticeable to drivers. Institutional to the success of this approach, seems to have been a warning based on a time algorithm. As opposed to the system oriented warning based on the system's maximum deceleration capability, it formed a person-centred warning allowing the adaptation of feedback to driver's perceptual and cognitive abilities. This was reflected on the one hand, by drivers' ability to predict the system's limits more efficiently i.e. reducing the number of false alarms (driver interventions when it was not necessary) and misses (collision or near collisions). On the other hand, by enabling drivers to acquire the sensitivity of the required response. This was demonstrated in the significant differences between conditions in distance error, adequate deceleration rates and panic braking when reclaiming control.

The personalised timing of feedback was also assisted by an intuitive display. At the warning level, the continual 'looming' visual stimulus was easily interpreted by participants, showing support for the research on the effectiveness of this type of headway feedback (Groeger & Brady, 1999; van der Horst, 1990; Yilmaz & Warren, 1995). At the alarm level, results showed that short acoustic tones were most suited compared to speech (Belz, 1997), that requires more time to comprehend, in time critical instances. Finally, a two-step warning strategy appeared to be effective in communicating the urgency of the forward target without being a nuisance to the driver, showing favour in the discussion of the effectiveness of two- rather than a single-step alarm (Kiefer et al., 1999).

The comparatively reduced peaks in drivers' workloads and faster recovery effects as measured by the PDT task, shows further support of the acquired 'ease' from the warning support, to predict the need to reclaim control and execute the take-over task appropriately.

Display effects were observed in time-to-collision and reaction times. These effects were not expected but are conform with the tenets of the risk homeostasis theory (Wilde, 1994). The level of perceived intrinsic risk was decreased, which led to drivers' later interventions. Subjectively, drivers in the enhanced display condition felt safer, and felt that the system had helped them to predict when to take over control and in applying the adequate braking force. These results were comparable to those of Lee (1999) and show support for the positive correlation between trust and automation propounded by Muir & Morray (1996).

The tutor system study was based on the results from the field study and the warning study formed a logical continuation from the results of the tutor study, focusing on the most critical and learn-intensive aspect addressed in the tutor system: the decision-making task involved in take-over situations. Due to its criticality in the learning phase, it would be reasonable to compare the effects of both approaches. However, warning a driver of an imminent crash compared with giving advisory information projects fundamental differences in the design implications of the systems. The advisory display of the tutor system served largely as a continual training tool, issuing speech outputs as advisory and reactive feedbacks on drivers' interactions. The warning display, however, used visual feedback to warn of potential danger and a short acoustic auditory tone that required a correct and immediate response for crash avoidance. Both studies featured some form of adaptive learning environment, but featured two different adaptation procedures: micro- in the tutor system and macro-adaptation in the warning system. Thus, the fundamental differences between the systems would make any endeavours towards the comparison of the results on drivers' performance questionable.

7.1 Comments on the evaluation methods

7.1.1 Field study

The data from the field provided a valuable insight into drivers' interactions with the system. Mainly due to the long-term usage, changes in behaviour were observable over time. Moreover, driver strategies were exhibited, which, given the short time and precise instructions were not, at least in this form, observable in the simulator. Nonetheless, until extraneous variables such as time of day, traffic, road type, visibility could be appropriately controlled, considerable organisatory effort and time needed to be invested.

The quality of the data was different compared to the data gathered from the simulation. The data from the field does not carry as much weight as no pressure was applied during the drives on drivers braking decisions due to the possibility of taking different evasive action to avoid danger or to keep the set desired speed. To be able to make a general statement on the differences between drivers' behaviour a larger sample set would be favourable. As soon as a fully developed intelligent help-system for ADAS is available, long-term studies are commendable – in the field as well as in the simulator – to evaluate drivers' interactions. The learning phase would be of primary concern here. The development of user strategies through drivers' interactions over time could be observed while keeping the variance of the measurement values to a minimum. A factor or cluster analysis of the available data could be a valuable input to the differentiation of traffic situations for the compiling of test routes for future ADAS experiments. Detailed knowledge of situation-related influences on drivers workload would further be a valuable contribution towards the standardisation and optimisation of a procedure specific to ADAS learning.

7.1.2 Driving simulator

Many of the previously outlined advantages of simulation methods over field studies were applicable in empirical studies on learning to drive with ADAS. Importantly, the conducting of experiments posed no threat to traffic safety. As many critical situations were tested, this represented a considerable advantage over the a field study. Also, the reproducibility and controllability of the independent variable 'traffic situation' allowed for a reduced sample set. Overall, the use of simulation helped to reduce costs and led to a faster production of the experimental equipment.

Particularly in approach and lead vehicle braking situations, the high graphical frame rate and graphical properties of the BMW driving simulator were of great advantage to the studies. Remaining to be cleared, however, is the extent to which proprioceptive cues or information from other channels might have altered participants' deceleration manoeuvres.

Even though moving-based simulators do have limitations (Nilsson, 1993), the lack of moving fidelity seems to be the biggest drawback of the research. Critics have pointed out that a driving simulator that does not incorporate movement is unlikely to provide all the relevant cues that the ACC system is causing the vehicle to decelerate. It is anticipated that this kinaesthetic information could assist drivers in appraising the situation and, hopefully, intervene. This would be a logical extension of the studies that could be tested in follow-up studies. Stanton & Young's (1998) comparison of moving and fixed-base simulators in drivers' ability to reclaim control of the system during ACC driving show, however, that results are comparable.

Within the studies, TTC was proved to be the most reliable measure for assessing drivers' ability to predict the need for intervention in take-over situations. As research on TTC estimation (Hancock & Manser, 1997; Taieb-Maimon & Shinar, 2001; Tresilian, 1995) has shown, the source of information for estimating TTC is the expansion of the approaching object. The critical traffic scenarios that led to take-over situations where both vehicles are in motion i.e. following situation in which the lead vehicle suddenly applies the brake or approach to a vehicle at a difference relative speed, are situations where there is little visual information to be gained from the environment about absolute speed of approach as the streaming information is not available and nor is the information relating to the absolute velocity between the vehicles. The only source of information for estimating TTC would then appear to be the change in visual angle (or expansion) of the lead vehicle. In this situation, Hoffman & Mortimer (1994) found the amount of underestimation of the TTC was considerably reduced. Thus, the physical fidelity of the visual expansion of the lead vehicle seems to be the most prominent and critical source of information in the analysed take-over situations. Since the graphical properties of optical perspective, visual angle and optical expansion rate were the same as in real world driving, the results would suggest that the use of a fixed simulator for assessing drivers' learning of the ACC system does not seem to have been compromised by the lack of proprioceptive information. However, although there is reason to believe that data from the fixed-base simulator may be valid, it is meaningful to draw conclusions on the relative effect size due to the results relative validity, as opposed to absolute validity. To validate the results, the systems would need to be tested on the open road. It is to be expected that the experimental effects would be the same in real conditions.

7.2 Implications and recommendations for the design of ADAS

Ultimately, research such as that presented in this thesis should be able to propose suggestions for design of future systems. Such could take any of the following forms: not to automate, not to automate until technology becomes more intelligent, to automate wherever possible, to use technology to monitor and advise rather than replace or, in compliance to the approaches presented, to use technology to assist and provide additional feedback rather than replace. The main focus was not a system-oriented, engineering centred approach with emphasis on the acceptance and adaptation from manual driving, but far more a person-centred approach with focus on the separate parts of the learning problem and the information, warning and advice necessary to help drivers better understanding and operation of the system. Various multimodal adaptation concepts from a learn-adaptive tutor system with feedback control of the learning process to an adaptable multi-stage warning system were tested to accelerate the process towards skill acquisition and improve drivers interactions with the system. The display design of these ADAS support systems tried to exploit human characteristics of

learning and memorising, perception i.e. assessing distance, motion and speed, motor skills and processing information and to actively support them. The dependent variables used to test the support systems ranged from reaction time and time-to-collision to the number of operational and prediction errors, that proved to be a particularly informative measure. On the basis of the knowledge gained, general recommendations for the HMI design of ADAS systems can be formulated. The design recommendations have been derived from the empirical evaluations of the ACC help-systems tested in the field and driving simulator studies.

Individualise help

- A more effective operation of the system (i.e. reduced operational errors), and a better understanding of the system is achieved by monitoring the driver's effectiveness in interacting with the system, and adaptively advising the driver what to do when the observed effectiveness is low. This micro-adaptation approach, gives the driver domain-specific knowledge of the system and how to perform a task through adaptive instruction and contextual advice in accordance to the driver's learning stage and level of skill.
- A macro-adaptation approach enabled a better understanding of the rules of controller behaviour and limits. By externally adapting the feedback instructions, the approach gave drivers the metacognitive skills to predict the need to regain control in critical and semi-critical situations, when drivers are often operating at their information processing capacity limit.

Use adequate modality for the presentation of information

- Use adequate modality: speech can be used at the strategical and operational behavioural levels.
- At the tactical level, when timing is often the most important factor, visual warnings and an acoustic alert are most effective.
- The potential danger of a situation should be communicated visually to reduce driver annoyance, while acoustic alerts should be used only when driver action is absolutely necessary.
- The visual display should be easily understood and interpretable. Looming provided a natural mapping and was an effective way to communicate urgency (and the potential danger) of a forward target. The changes in the multi-colour icon were often not perceived, thus a maximum of two changes in colour is recommended.

- Provide redundancy: system performance feedback should communicate system limits and redundantly warn of the actual danger.
- Provide direct continuous performance feedback through simple communication.

Optimise warnings for more system transparency

- The use of a time measure for the emittance of warnings has the advantage that it immediately reacts to the danger avoidance action taken by the driver e.g. deceleration manoeuvre, directly influencing the calculation of the time reserve as well as situational parameters. The driver thus receives a direct feedback of the exactness of his or her action. Moreover, it allows for a personalised reaction time to be integrated in the warning emittance algorithm.
- Adapting warnings to (stable) aspects of motivational driver behaviour i.e. braking preference or risk handling, increases drivers' acceptance of the system and enables a faster integration of the system and a better response sensitivity.
- A two-stage warning, in comparison to a single-stage warning, allows the warning system to provide an appropriate degree of intrusiveness at differing levels of urgency.

Reduce peaks in workload

- To reduce peaks in driver workload, supplement a warning of the possible need for intervention with an alarm based on a driver-dependent limit that incorporates human cognitive capabilities and perceptual motor skills i.e. braking to avoid a collision, and which, when necessary, prompts the driver to take immediate danger avoidance.
- 'Train' ADAS to recognise situations in which situational demands are high and adjust its response and feedback in accordance (workload manager).

Prioritise and centralise information

- The provision of information to drivers needs to be prioritised. Sequencing of the emitted information should be made in accordance to safety relevance, time urgency and operational relevance respectively. Similarly, during interaction and feedback from ADAS, information from driver information systems (DIS) should be avoided. This may at first seem odd, if learning is needed to execute operational tasks. There is, however, relatively little learning of the motor component but considerable learning of the perceptual and cognitive components. It is postulated

that with practice, this activity stream will run in parallel to the other streams demanding virtually no attention.

- For the case of more than one advanced driver assistance system integrated into the vehicle, a single intelligent informational module should integrate and give support to the driver.

7.3 Further research and outlook

Within the framework of the presented studies, it was not possible to exhaust all the methodological and contextual questions. The need for research in the near future is, however, clearly recognisable, also in relation to the results from the studies and of their implications.

- The approach described in the first simulator study intended to directly control the driver's learning progress through a closed-loop tutor system. Further research is needed in order to explore the pro's and con's of implementing external control of learning processes of ADAS into the open learning environment.
- A "meta" adaptation principle would be to flexibly switch between a control and a warning strategy and smoothly fade out external control whenever and as soon as possible. This approach would incorporate advantages from both of the proposed concepts. Further investigation would need to assess its effects on drivers' interactions with ADAS.
- The evaluation of a two-step personalised warning system should be extended to all types of take-over situations based upon the definition of the detection parameters from the long-term study.
- Drivers can carry out a number of tasks at the same time, but most of them will take place at the skill level, hence requiring little attention. One thing we need to know more about is how something becomes a skill i.e. how automatic performances are produced. Although this is one of the oldest problems in psychology, no acceptable explanation exists. Some of the factors playing a role in the context of ADAS were presented here, but exactly how to identify a transition or what guides the transition from, for example, rule-based behaviour to skill-based behaviour is not clear, at least not in the sense that it can be used further than post-hoc explanations. Promising parameters could be minimum TTC, TTC at intervention as well as the rate of adequate deceleration. These parameters seemed to follow a power speed-up in the standard group for situations in which the own and the lead vehicle drive with a constant speed difference towards one another. This was most marked at a speed difference at which the deceleration limits of the ACC system were almost reached. After 60-70 events, the parameters approached

those of the enhanced group. These results are not comparable to the long-term field study, which allowed different reactions to the situation. A long-term study of these parameters, tested against more traditional psychological methods of identifying transitions in skill acquisition, such as think aloud protocols would allow the validation of these parameters as indicators of transitions in the learning stages.

- In critical situations in particular, the importance of mental models and the predictions about system performance that are based on these mental models has often been underlined. Further research would be needed into how drivers construct mental models of the intelligent system(s), how it changes with experience and how it can be influenced in order to support the early development of a good mental model.
- The interplay between visual and acoustic display elements and their effects on workload should be given closer examination; in particular when longer acoustic speech warnings are given in conjunction with a visual feedback of the system mode in critical or semi-critical situations. In these situations, or take-over situations, the effects on drivers' workload of a Head-up-Display (HUD) or other displays inside the car could be evaluated.
- On the level of several interacting intelligent help-systems, more knowledge is needed concerning the relation between drivers' workload (in terms of static as well as dynamic aspects of different traffic situations) and the help-systems. This can help identify situations where presentation of extra information should either be avoided, or made in some special way without endangering the traffic situation.
- On the level of single intelligent tutor systems, more knowledge of cognitive characteristics and learning is needed in order to optimise the information presentation, that is, to improve drivers' possibilities to perceive, interpret and understand the messages from the systems.
- Developing a warning system implies first the implementation of some complex, multi-array detection system. In itself this is a considerable engineering challenge. However, having derived a veridical warning system, for its personalisation to drivers of widely different abilities and preferences, more effort would be needed to specify the dynamic man-machine interaction between drivers and cognitive ADAS support.
- In the long-term, a simple, practicable but valid methodology for the evaluation of the learning effects in connection with ADAS is to be developed. Based on the experience gathered from simulator and field studies it should be able to be carried out by experts or as an automatic procedure, preferably without having to assign participants.

8 REFERENCES

- ACC. (2000). Supplementary Owner's Handbook. Active Cruise Control (ACC). *Online Edition for Part No. 01410155373*. BMW AG.
- Alessi, S. M., & Trollip, S. R. (1991). *Computer-based instruction: Methods and development (2nd ed.)*. Englewood Cliffs, NJ: Prentice-Hall.
- Alm, H., Sviden, O., & Waern, Y. (1997). Cognitive ITS: On cognitive integration of ITS functions around the driver's task. In I. Y. Noy (Ed.), *Ergonomics and safety of intelligent driver interfaces*. Mahwah: Lawrence Erlbaum Assoc.
- Anderson, D. I., Magill, R. A., & Sekiya, H. (2001). Motor learning as a function of KR schedule and characteristics of task-intrinsic feedback. *Journal of Motor Behaviour*, 33(1), 59-66.
- Anderson, J. R. (1993). *Rules of the Mind*. Hillsdale, NJ: Erlbaum.
- Anderson, J. R. (2000). *Learning and memory: an integrated approach (2nd ed.)*. John Wiley & Sons Inc.
- Anderson, J. R., Corbett, A. T., Koedinger, K., & Pelletier, R. (1995). Cognitive tutors: lessons learned. *The Journal of Learning Sciences*(4), 167-207.
- Aschenbrenner, K. M., & Biehl, B. (1994). Improved Safety Through Improved Technical Measures? In R. Trimpop & G. J. S. Wilde (Eds.), *Challenges To Accident Prevention: The issue of risk compensation behaviour*. Groningen: STYX-Publications.
- Bachmann, T., Naab, K., Reichart, G., & Schraut, M. (2000). *Enhancing traffic safety with BMW's driver assistance approach connected drive*. Paper presented at the ITS World Conference, Turin.
- Bainbridge, L. (1983). Ironies of automation. *Automatica*, 19, 775-779.
- Bainbridge, L. (1992). Mental models in cognitive skill: the example of industrial process operation. In Y. Rogers, A. Rutherford & P. A. Bibby (Eds.), *Models in the Mind: Theory, Perspective and Application* (pp. 119-143). London: Academic Press.
- Baumann, M., Rösler, D., Jahn, G., & Krems, J. F. (2003). Assessing driver distraction using Occlusion Method and Peripheral Detection Task. In K. Strasser, K. Kluth, H. Rausch & H. Bubb (Eds.), *Quality of work and products in enterprises of the future* (pp. 53-56). Stuttgart: Ergonomia.
- Becker, S., Brandenburg, K., Feldges, J., Fowkes, M., Johannig, T., & Kopf, M. (1999). *System, user and legal aspects. The integrated approach for the assessment of driver*

- assistance systems*. (Response: Project TR4022). Bruxelles: Commission of the European Communities.
- Becker, S., Brauswetter, C., Brockmann, M., Hofmann, O., Krause, R., Mihm, J., et al. (1997). *Experimentelle Analyse von Anwenderbedürfnissen innerhalb der Entwicklung von Fahrerunterstützungssystemen*. Paper presented at the VDI-Gesellschaft Fahrzeug- und Verkehrstechnik, Der Mensch im Straßenverkehr, Düsseldorf.
- Becker, S., Sonntag, J., & Krause, R. (1994). *Zur Auswirkung eines intelligenten Tempomaten auf die mentale Belastung des Fahrers, seine Sicherheitsüberzeugungen und (kompensatorischen) Verhaltensweisen* (Prometheus-Projekt EU 45 Phase II, TV 8940 4). Köln: TÜV Rheinland, Institute für Verkehrssicherheit.
- Belz, S. M. (1997). *A simulator-based investigation of visual, auditory and mixed-modality display of vehicle dynamic state information to commercial motor vehicle operators*. Master Thesis, Polytechnic Institute and State University, Virginia.
- Bengler, K. (1995). *Gestaltung und experimentelle Untersuchung unterschiedlicher Präsentationsformen von Wegleitungsinformation in Kraftfahrzeugen*. PhD Thesis, Universität Regensburg, Regensburg.
- Bengler, K. (2004). Subjective testing for evaluation of driver information systems and driver assistance systems learning effects and methodological solutions.
- Bengler, K., Huesmann, A., & Praxenthaler, M. (2003). *Investigation of visual demand in a static driving simulator within the ADAM project*. Paper presented at the GfA, München.
- Ben-Yaakov, A., Maltz, M., & Shinar, D. (2000). *Driver Performance with a Collision Avoidance System*. Paper presented at the The Human Factors and Ergonomics Society Annual Meeting, San Diego.
- Bernasch, J., & Haenel, S. (1995). *The BMW driving simulator used for development of a driver-biased adaptive cruise control*. Paper presented at the Driving Simulator Conference DSC'95, Sophia Antipolis, France.
- Bilodeau, E. A. (1969). Supplementary feedback and instructions. In E. A. Bilodeau (Ed.), *Acquisition of skill*. New York: NY: Academic.
- Bjork, R. A. (1998). Assessing our own competence: heuristics and illusions. In Gopher & Koriat (Eds.), *Cognitive regulation of performance: interaction of theory and application. Attention and Performance XVII*. (pp. 435-459). Cambridge, MA: MIT Press.
- Blana, E., & Golias, J. (1999). *Behavioural validation of a fixed-base simulator*. Paper presented at the Driving Simulation Conference (DSC'99), Paris.

- Breitenberger, S. (1998). *Einschätzung aktueller Verkehrszustände aus fahrzeuggenerierten Daten*. Diplomarbeit BMW AG, München.
- Broadbent, D. E. (1982). Task combination and selective intake of information. *Acta Psychologica*, 50, 253-290.
- Brockmann, M., Becker, S., Husemann, T., Mertens, A., Niu, R., & Sonntag, A. (1995). *Integrierte Mensch-Maschine Schnittstelle für die Fahrzeugregelung*. (Arbeitspaket 4: AICC - Prototypenevaluation). Köln: TÜV Rheinland.
- Brook-Carter, N., Parkes, A. M., Burns, P., & Kersloot, T. (2002). *An investigation of the effect of an urban Adaptive Cruise Control (ACC) system on driving performance*. Paper presented at the 9th World Congress on Intelligent Transport Systems, Chicago, Illinois.
- Brookhuis, K. A., & De Waard, D. (1999). Limiting speed, towards an intelligent speed adaptor (ISA). *Psychology and Behaviour, Transportation Research, Part F*, (2), 81-90.
- Bundesamt. (2003). *Verkehr/ Verkehrsunfälle 2002*. Fachserie 8/ Reihe 7, Wiesbaden: Hrsg. Statistisches Bundesamt.
- Card, S. K., Moran, T. P., & Newell, H. A. (1983). *The psychology of human-computer interaction*. Hillsdale, NJ: Lawrence Erlbaum Associates.
- Carsten, O. M. J., Groeger, J. A., Blana, E., & Jamson, A. H. (1997). *Driver performance in the EPSRC driving simulator: a validation study* (Report Nr. GR/ K56162). United Kingdom: University of Leeds.
- Chaloupka, C., Risser, R., Antoniadis, A., Lehner, U., & Praschl, M. (1998). *Auswirkungen neuer Technologien im Fahrzeug auf das Fahrverhalten* (Berichte der Bundesanstalt für Straßenwesen, Heft M 84). Gladbach: BAST.
- Cognition and Technology Group at Vanderbilt. (1993). Anchored instruction and situated cognition revisited. *Educational Technology*, 33(3), 52-70.
- Collins, A., Brown, J. S., & Newmann, S. E. (1989). Cognitive apprenticeship: Teaching the crafts of reading, writing and mathematics. In L. B. Resnick (Ed.), *Knowing, Learning and Instruction*. Hillsdale, New Jersey: Lawrence Erlbaum Publishers.
- Comte, S., & Jamson, A. H. (1998). *The effects of ATT and non-ATT systems and treatments on speed adaptation behaviour* (Contract No. RO-96-SC.202). Finland: VTT.
- Cooke, N. J. (1999). Knowledge elicitation. In F. T. Durso (Ed.), *Handbook of Applied Cognition*. UK: Wiley.
- Davis, D., Schweizer, N., Parosh, A., Lieberman, D., & Apter, Y. (1990). *Measurement of the minimum reaction time for braking vehicles*. Israel: Wingate Institute for Physical Education and Sport.

- De Waard, D., & Brookhuis, K. A. (1997). Behavioural adaptation of drivers to warning and tutoring messages: results from on-the-road and simulator tests. *International Journal of Vehicle Design*, 4, 222-234.
- De Waard, D., & Rothengatter, J. A. (1998). *Measuring driver behaviour*. Paper presented at the 2nd International Conference on Methods and Techniques in Behavioral Research, Groningen, The Netherlands.
- De Ward, D., Van der Hulst, M., Hoedemaeker, M., & Brookhuis, K. (1999). Driver behaviour in an emergency situation in the automated highway system. *Transportation Human Factors*, 1(1), 67-82.
- Delaney, P. F., Reder, L. M., Staszewski, J. J., & Ritter, F. E. (1998). The strategy-specific nature of improvement: the power law applies by strategy within task. *Psychological Science*, 9, 1-7.
- Desmond, P. A., Hancock, P. A., & Monette, J. L. (1998). Fatigue and automation-induced impairments in simulated driving performance. *Transportation Research Record*(1628), 8-14.
- Dingus, T. A., Jahns, S. K., Horowitz, A. D., & Knipling, R. (1998). Human factors design issues for crash avoidance systems. In W. Barfield & T. A. Dingus (Eds.), *Human Factors in Intelligent Transportation Systems* (pp. 55-94). London: Lawrence Erlbaum.
- Dingus, T. A., McGehee, D. V., Manakkal, N., Jahns, S. T., & Hankey, J. M. (1997). Human factors field evaluation of automotive headway maintenance/, collision warning devices. *Human Factors*, 39(2), 216-229.
- Dorißen, T., & Hoever, N. (1996). Autonome Intelligente Geschwindigkeitsregelung (AICC). Ein Beitrag zur Steigerung des Komforts und der aktiven Fahrsicherheit. *Automobiltechnische Zeitschrift*, 98(7/8), 294-405.
- Durso, F. T., & Gronlund, S. D. (1999). Situation awareness. In F. T. Durso, R. Nickerson, R. Schvaneveldt, S. Dumais, M. Chi & S. Lindsay (Eds.), *The handbook of Applied Cognition* (pp. 283-314). New York: Wiley.
- Ehmans, D. (2002). *Roadmap: Future development of ADAS*. Paper presented at the ADASE 2, Expert Workshop on vehicle to vehicle and vehicle to infrastructure communication, Paris.
- Ehmans, D., Wallentowitz, H., Gelau, C., & Nicklisch, F. (2000). *Zukünftige Entwicklung von Fahrerassistenzsystemen und Methoden zu deren Bewertung*. Paper presented at the 9. Aachener Kolloquium Fahrzeug- und Motorentechnik, Aachen.
- Ehmans, D., Zahn, P., Spannheimer, H., & Freymann, R. (2003). Integrated longitudinal and lateral guidance control. *ATZ Worldwide*, 105(4), 10-13.

- Endsley, M. R. (1995). Towards a Theory of Situation Awareness. *Human Factors*, 37(1), 32-64.
- Endsley, M. R. (2000). *Situation models: an avenue to the modelling of mental models*. Paper presented at the IEA 2000/HFES 2000 Congress, San Diego, California, USA.
- Endsley, M. R., & Kiris, E. O. (1995). The out-of-the-loop performance problem and level of automation. *Human Factors*, 37, 381-394.
- ETSC. (2000). *Reducing the severity of road injuries through post impact care*. Brussels: European Transport Safety Council.
- Evans, L. (1991). *Traffic safety and the driver*. New York: Van Nostrand Reinhold.
- Fairclough, S. H., May, A. J., & Carter, C. (1993). The effect of time headway feedback on following behaviour. *Accident Analysis and Prevention*, 29, 387-397.
- Fancher, P., Bareket, Z., & Ervin, R. (2001). Human-centered design of an ACC-with-braking and forward-crash-warning system. *Vehicle System Dynamics*, 36(2-3), 203-223.
- Fancher, P., Ervin, R., Sayer, J., Hagan, M., Bogard, S., Bareket, Z., et al. (1998). *Intelligent Cruise Control Field Operational Test* (No. DOT HS 808 849, UMTRI-98-17). Michigan: University of Michigan Transportation Research Institute.
- Fancher, P. S., & Ervin, R. D. (1998). Adaptive Cruise Control - Field Operational Test. *The UMTRI Research Review*, 29(4), 1-17.
- Färber, B., Färber, B., & Schmitt, J. (2001). *Informationsmanagement für Fahrerassistenz-Systeme mittels Prädiktion der Fahrerbelastung*. Paper presented at the 4. Berliner Werkstatt Mensch-Maschine-Systeme, Berlin.
- Fastenmeier, W., & Gstalter, H. (1998). *Situationsanalyse und Funktionsspezifikationen von ACC*. (Forschungsbericht im Rahmen von MOTIV/ACC im Ballungsraum/ AP1, im Auftrag der BMW AG, Robert Bosch GmbH, MAN Nutzfahrzeuge AG, Adam Opel AG, Volkswagen AG.). München: Diagnose & Transfer - Institute für Angewandte Psychologie.
- Fecher, N., Degenstein, T., Dückert, C., Girg, H., Henßen, A., Huckauf, F., et al. (2002). *Abschlußbericht, Situations-angepasste und Nutzer-Typ-zentrierte Optimierung von Systemen zur Fahrerunterstützung (SANTOS)*. Darmstadt: Technische Universität.
- Fitts, P. M., & Posner, M. I. (1967). *Learning and skilled performance in human performance*. Belmont CA: Brock-Cole.
- Freyman, R., Gresser, K., & Spannheimer, H. (2002). ConnectedDrive: an integrated approach to improve vehicle safety and comfort. *JSAE*.
- Fuller, R. (1984). A conceptualisation of driving behaviour as threat avoidance. *Ergonomics*, 27, 1139-1155.

- Gerisch, H. (2001). *Fahrsimulatorrealisierung eines multimodalen Hilfesystems zur Verständlichkeitsverbesserung eines Fahrerassistenzsystems*. Diplomarbeit, BMW AG, München.
- Godley, S. T., Fildes, B. N., & Triggs, T. J. (1997). *Driving simulator validation for speeding countermeasures research*. Paper presented at the Second International Simtect Conference, Canberra, Australia.
- Godthelp, J., & Schumann, J. (1991). *The use of an intelligent accelerator as an element of a driver support system*. Paper presented at the 24th ISATA International symposium on automotive technology and automation., Croydon, England.
- Goodrich, M. A., & Boer, E. R. (2000). Designing human-centered automation: tradeoffs in collision avoidance system design. *IEEE Transactions on Intelligent Transportation Systems*, 1(1), 40-54.
- Green, W. S., & Jordan, P. W. (2002). *Pleasure with products: Beyond usability*. London: Taylor & Francis.
- Groeger, J. A. (1997). *Memory and Remembering: Everyday Memory in Context*. Harlow, UK: Longmann.
- Groeger, J. A. (2000). *Understanding driving: applying cognitive psychology to a complex everyday task*. East Sussex: Psychology Press.
- Groeger, J. A., & Brady, S. J. (1999). Tau dot or not? Visual information and control of car following. In A. G. Gale (Ed.), *Vision in Vehicles VII*. Amsterdam: Elsevier.
- Groeger, J. A., & Grande, G. E. (1996). Self-preserving judgements of skill. *British Journal of Psychology*, 87, 61-79.
- Grudin, J. (1992). Utility and usability: research issues and development contexts. *Interacting with Computers*, 4(2), 209-217.
- Guerin, B. (1994). What do people think about the risks of driving? Implications for traffic safety interventions. *Journal of Applied Social Psychology*, 24, 994-1021.
- Gugerty, L. J. (1997). Situation awareness during driving: explicit and implicit knowledge in dynamic spatial memory. *Journal of Experimental Psychology: Applied*, 3, 42-66.
- Hancock, P. A., & Manser, M. P. (1997). Time-to-contact: more than tau alone. *Ecological Psychology*, 9, 265-297.
- Hancock, P. A., & Parasuraman, R. (2003). Human factors and ergonomics. In G. Salvendy (Ed.), *Handbook of Cognitive Science* (pp. 420-418). San Diego: Academic Press.
- Hancock, P. A., Parasuraman, R., & Byrne, E. A. (1996). Driver-centred issues in advanced automation for motor vehicles. In R. Parasuraman & M. Mouloua (Eds.), *Automation and Human Performance: Theory and Applications* (pp. 337-364). New Jersey: Lawrence Erlbaum Ass.

- HASTE. (2003). *Human Machine Interface And the Safety of Traffic in Europe, Project GRD1/2000/25361 S12.319626*.
- Hattori, Y. K., Asano, N., Iwama, N., & Shigematsu, T. (1995). A decelerating driver model in a car-following situation. *Vehicle System Dynamics*, 24, 299-311.
- Hochstadter, A., Ehmanns, D., & Neunzig, D. (1999). *PELOPS as a tool for development and configuration of driver assistance systems*. Paper presented at the Euromotor Seminar, Telematic/Vehicle and Environment: Adaptive Cruise Control - Series Introduction and Future Development, Aachen.
- Hochstadter, A., Zahn, P., & Breuer, K. (2001). *A comprehensive driver model with application to traffic simulation and driving simulators*. Paper presented at the 1st Human-Centered Transportation Simulation Conference, Iowa City.
- Hoedemaeker, M. (1999). *Driving with intelligent vehicles. Driving behaviour with adaptive cruise control and the acceptance by individual drivers*. PhD Thesis, Delft University, Delft.
- Hoffman, E. R., & Mortimer, R. G. (1994). Drivers' estimates of time to collision. *Accident Analysis and Prevention*(26), 511-520.
- Hogema, J. H., & Janssen, W. H. (1996). *Effects of Intelligent Cruise Control on driving behaviour: a simulator study* (Report TM-96-C012). Delft, The Netherlands: TNO Human Factors Research Institute.
- Hogema, J. H., van Arem, B., Smulders, S. A., & Coemet, M. J. (1997). Modelling changes in driving behaviour: on the effects of Autonomous Intelligent Cruise Control. In J. A. Rothengatter & E. C. Vaya (Eds.), *Traffic and Transport Psychology, Theory and Application*. Oxford: Pergamon Press.
- Hogema, J. H., van der Horst, R., & Janssen, W. H. (1994). *A simulator evaluation of different of different forms of Intelligent Cruise Control* (Report TM C-30). Delft: TNO Human Factors Institute.
- Hogema, J. H., van der Horst, R., & Janssen, W. H. (1995). *Linking roadside communication and Intelligent Cruise Control; effects on driving behaviour*. Paper presented at the 5th International EAEC Congress, Strasbourg.
- Hollnagel, E. (1998). *Cognitive reliability and error analysis method(CREAM)*. Oxford: Elsevier Science Ltd.
- Horowitz, A. D., & Dingus, T. A. (1992). *Warning signal design: A key human factors issue in an in-vehicle front-to-rear-end collision warning system*. Paper presented at the Proceedings of the Human Factors Society 36th Annual Meeting.
- Hoyes, T. W., Stanton, N. A., & Taylor, R. G. (1996). Risk homeostasis theory: a study of intrinsic compensation. *Safety Science*, 22(1-3), 77-86.

- Huang, A.-C., & Chen, Y. J. (2001). Safe platoon control of automated highway systems. *Journal of Systems and Control Engineering*, 215, Part 5, 531-544.
- Huesmann, A., Wisselmann, D., & Freymann, R. (2003). Der neue dynamische Fahrsimulator der BMW Fahrzeugforschung. *VDI-Berichte*, 1745, 59-67.
- Hughes, D. (1995). Studies highlight automation "surprises". *Aviation Week & Space Technology*(2), 48-49.
- ISO 9241-11. (1994). Ergonomic requirements for office work with visual display terminals (VDTs), Part 11: Guidance on usability specification and measures, ISO DIS, 9241-11.
- ISO 15005. (2000). Straßenfahrzeuge - Ergonomische Aspekte von Fahrerinformations- und -assistenzsystemen - Grundsätze und Prüfverfahren des Dialogmanagements, ISO DIS, TC22/SC.
- ISO 15622. (2001). Road vehicles - Adaptive Cruise Control Systems - Performance requirements and test procedures, ISO DIS, 15622.
- Jahn, G., Krems, J. F., & Gelau, C. (2002). Skill-development when interacting with in-vehicle information systems: a training study on the learnability of different MMI concepts. In D. De Waard, K. A. Brookhuis, J. Moraal & A. Toffetti (Eds.), *Human Factors in Transportation, Communication, Health, and the Workplace*. Maastricht, The Netherlands: Shaker Publishing.
- Jamson, H. (1999). *Curve negotiation in the Leeds driving simulator: a validation study*. Paper presented at the Driving Simulation Conference (DSC'99), Paris.
- Johnson, C. W. (1996). The role of error tolerant design in minimising the impact of risk. *Safety Science*, 22(1), 195-214.
- Jordan, P. W. (1994). What is usability? *Contemporary Ergonomics*, 454-458.
- Jordan, P. W. (1998). *An introduction to usability*. London: Taylor & Francis.
- Jordan, P. W., Draper, S. W., MacFarlane, K. K., & McNulty, S.-A. (1991). Guessability, learnability and experienced user performance. In D. Diaper & N. Hammond (Eds.), *People and Computers VI* (pp. 237-245). Cambridge: University Press.
- Kanaris, A., Kosmatopoulos, E. B., & Ioannou, P. A. (2001). Strategies and spacing requirements for lane changing and merging in Automated Highway Systems. *IEEE Transactions on Vehicular Technology*, 50, Part 6, 1568-1581.
- Kaptein, N. A., Theeuwes, J., & Van der Horst, R. (1996). Driving simulator validity, some considerations. *Transportation Research Record*, 1550, 30-36.
- Kiefer, R., LeBlanc, D., Palmer, M., Salinger, J., Deering, R., & Shulman, M. (1999). *Development and validation of functional definitions and evaluation procedures for collision warning/avoidance systems* (DTNH22-95-H-07301). Washington, DC: National Highway Traffic Safety Administration.

- Knipling, R. R., Mironer, M., Hendricks, D. L., Tijerina, L., Everson, J. C., & Wilson, C. (1993). *Assessment of IVHS countermeasures for collision avoidance: rear-end crashes* (No. DOT-HS-807-995). Washington D.C.: National Highway and Traffic Safety Administration.
- König, W., Weiss, K.-E., Gehrke, H., & Haller, R. (2000). *S.A.N.T.O.S: Situations-angespasste und Nutzer-Typ-zentrierte Optimierung von Systemen und Fahrerunterstützung*. Paper presented at the GfA, Ergonomie und Verkehrssicherheit, München.
- Kopf, M. (1994). *Ein Beitrag zur modellbasierten, adaptiven Fahrerunterstützung für das Fahren auf deutschen Autobahnen*. PhD Thesis, Universität der Bundeswehr, Fortschritt-Berichte VDI-Verlag, Düsseldorf.
- Kopf, M., & Becker, S. (2000). *Response: Klärung der Rahmenbedingungen bei der Markteinführung von Fahrerassistenzsystemen in Europa*. Paper presented at the 9. Aachener Kolloquium Fahrzeug- und Motorentechnik, Aachen.
- Kopf, M., & Nirschl, G. (1997). *Driver-vehicle interaction while driving with ACC in borderline situations*. Paper presented at the Intelligent Transport Systems and Services (ITS).
- Kopf, M., & Simon, J. H. (2001). *A concept for a learn-adaptive advanced driver assistance system*. Paper presented at the 8th European Conference on Cognitive Science Approaches to process Control (CSAPC'01), Munich.
- Kopf, M., & Simon, J. H. (2003). DE Patent Nr. PA10241922. Deutschland: Internationale Patent- und Markeamt.
- Kröner, S. (2001). *Intelligenzdiagnostik per Computersimulation [Measuring intelligence by means of computer simulations]*. Münster: Waxmann.
- Krüger, H.-P. (2000). *Einfluss des Lernprozesses auf die Interaktion mit Fahrerassistenzsystemen. Angebot an die Forschungsvereinigung Automobiltechnik e.V.* Würzburg: Interdisziplinäres Zentrum für Verkehrswissenschaften.
- Krüger, H.-P., Neukum, A., & Schuller, J. (2000). A Workload Approach to the Evaluation of Vehicle Handling Characteristics. *SAE, 2000-01-0170*.
- Kuhlmann, A. (1981). *Einführung in die Sicherheitswissenschaft*. Köln: TÜV Rheinland.
- Kulik, J. A., & Kulik, C.-I. C. (1988). Timing of feedback and verbal learning. *Review of Educational Research, 58*(1), 79-97.
- Lee, J. D. (1999). *Measuring driver adaptation to in-vehicle information systems: Disassociation of subjective and objective situation awareness measures*. Paper presented at the Human Factors and Ergonomics Society.

- Lee, T. D., & Magill, R. A. (1985). Can forgetting facilitate skill acquisition? In D. Goodman, R. B. Wilberg & I. M. Franks (Eds.), *Differing perspectives in motor learning, memory and control* (pp. 3-22). North Holland: Elsevier Science Publishers.
- Leutner, D. (2003). Instructional-design principles for adaptivity in open-learning environments. In N. M. Seel & S. Dijkstra (Eds.), *Curriculum, plans and processes of instructional design: international perspectives*. Mahwah, NJ: Lawrence Erlbaum.
- Levine, M. W., & Shefner, J. M. (1991). *Fundamentals of sensation and perception*. Monterey, CA: Brooks/Cole.
- Manser, M. P., & Hancock, P. A. (1996). The influence of approach angle on estimates of time-to-collision. *Ecological Psychology*, 8, 71-99.
- Martens, M. H., & van Winsum, W. (2000). *Measuring distraction: the Peripheral Detection Task*. Soesterberg, The Netherlands: TNO Human Factors.
- Mayser, C., Piechulla, W., Weiss, K.-E., & König, W. (2003). *Driver workload monitoring*. Paper presented at the 50th-Anniversary Conference of the GfA and the XVII Annual ISOES, Munich.
- Mc Laughlin, S., & Serafin, C. (1999). *Measurement of driver intervention responses during transition from ACC deceleration to manual control*. Paper presented at the ITS America, Washington DC.
- McKenna, F. P. (1988). What role should the concept of risk play in theories of accident involvement? *Ergonomics*, 31, 469-484.
- Meyer, J. (2001). Effects of warning validity and proximity on responses to warnings. *Human Factors*, 43, 217-226.
- Meyer, J., & Bitan, Y. (2002). Why better operators receive worse warnings. *Human Factors*, 44(3), 343-353.
- Michon, J. A. (Ed.). (1985). *A critical view of driver behaviour models: what do we know, what should we do?* New York: Plenum Press.
- Micron, J. A. (1993). *Generic intelligent driver support*. London: Taylor & Francis.
- Mock-Hecker, R. (1994). *Wissensbasierte Erkennung kritischer Verkehrssituationen - Erkennung von Plankonflikten*. Dissertation, Universität Karlsruhe, Düsseldorf: VDI-Verlag.
- Molin, E. J. E., & Brookhuis, K. (2001). *The acceptance of the Intelligent Speed Adapter: a causal analysis*. Paper presented at the 5th International Conference of Technology, Policy and Innovation, Delft.
- Moray, N. (1999). Mental models in theory and practice. In D. Gopher & A. Koriat (Eds.), *Attention and performance XVII: Cognitive regulation of performance: Interaction of theory and application*. *Attention and performance* (pp. 223-258): MIT Press.

- Moray, N., Dessouky, M. I., Kijowski, B. A., & Adapathya, R. (1991). Strategic behaviour, workload and performance in task scheduling. *Human Factors*, 33, 607-629.
- Mortimer, R. G. (1990). *Perceptual factors in rear-end collisions*. Paper presented at the Human Factors Society Annual Meeting.
- Muir, B. M., & Morray, N. (1996). Trust in automation. Part 2. Experimental studies of trust and human intervention in automated systems. *Ergonomics*, 37, 1905-1922.
- Naab, K. (2000). Automatisierung bei der Fahrzeugführung in Straßenverkehr. *Automatisierungstechnik*(5), 1-13.
- Naab, K. (2004). *Sensorik- und Signalverarbeitungsarchitekturen für Fahrerassistenz und Aktive Sicherheit*. Paper presented at the Aktive Sicherheit durch Fahrerassistenzsysteme Tagung, München.
- Näätänen, R., & Summala, H. (1974). A model for the role of motivational factors in driver's decision-making. *Accident Analysis and Prevention*, 6, 243-261.
- Nadjm-Therani, S. (1990). *Driver Interactions with a Signal Support System*. Paper presented at the Proceedings of the Third Prometheus Workshop, Turin.
- NHTSA. (2002). *National Highway Traffic Safety Administration. Traffic safety facts: A compilation of motor vehicle crash data from the Fatality Analysis Reporting System and the General Estimates System*. Washington, DC: U.S. Department of Transportation.
- Niedermaier, B., & Lang, M. (2001). *Ein Ansatz zur kontextfreien Repräsentation multimodaler Dialoge unter Berücksichtigung der Dialogqualität*. Paper presented at the 4. Berliner Werkstatt Mensch-Maschine-Systeme, Berlin.
- Nielson, J. (1993). *Usability engineering*. London: Academic Press.
- Nilsson, L. (1993). Simulator studies and driver behaviour. In A. M. Parkes & S. Franzen (Eds.), *Driving Future Vehicles* (pp. 401-407). London: Taylor & Francis.
- Nilsson, L. (1995). *Safety effects of adaptive cruise control in critical traffic situations*. Paper presented at the Second World Congress on Intelligent Transport Systems (ITS).
- Nirschl, G., & Blum, E. J. (1999). *Studie zur Fahrverhaltensuntersuchung bei der Benutzung von ACC-Systemen* (Ausführungsbericht zum Forschungsvorhaben Nr. 9 208 708 im Auftrag der BMW AG). Karlsruhe: Fraunhofer IITB.
- Nirschl, G., Blum, E. J., & Kopf, M. (2000). *Untersuchungen zur Benutzbarkeit und Akzeptanz eines ACC-Fahrerassistenzsystems* (IITB Mitteilungen). Dresden: Fraunhofer Institut für Informations- und Datenverarbeitung.
- Norman, D. A. (1990a). The problem with automation. *Philosophical Transactions of the Royal Society of London, B*, 1-18.
- Norman, D. A. (1990b). *The Psychology of Everyday Things*: Basic Books, US.

- Norman, D. A. (1998). *The Invisible Computer*. Cambridge, Massachusetts: MIT Press.
- Oborne, D. J. (1995). *Ergonomics at Work* (Third ed.): John Wiley & Sons.
- Olson, P. L., & Sivak, M. (1986). Perception-response time to unexpected roadway hazards. *Human Factors*, 28, 91-96.
- Olsson, S., & Burns, P. C. (2000). *Measuring driver visual distraction with a Peripheral Detection Task*. Linköping, Gothenburg, Sweden: Department of Education & Psychology, Volvo Technological Development Corporation.
- Onken, R., Otto, H.-J., & von Garrel, U. (2001). Adaptive Modellierung des Fahrerverhaltens - Ein Kernelement für die kognitive Kooperation bei zukünftiger Fahrerassistenz. In T. Jürgensohn & K.-P. Timpe (Eds.), *Kraftfahrzeugführung* (pp. 81-93). Berlin: Springer.
- Oppenheim, A. N. (1992). *Questionnaire design, interviewing and attitude measurement*. London: Continuum.
- Parasuraman, R. (2000). Designing automation for human use: empirical studies and quantitative models. *Ergonomics*, 43(7), 931-951.
- Parasuraman, R., Hancock, P. A., & Olofinboba, O. (1997). Alarm effectiveness in driver-centred collision-warning systems. *Ergonomics*, 40(3), 390-399.
- Parasuraman, R., & Riley, V. A. (1997). Humans and automation: use, misuse, disuse, abuse. *Human Factors*, 39, pp 230-253.
- Praxenthaler, M. (1999). *Die Auswirkungen unterschiedlicher ACC-Anzeigen auf Systemverständnis und Situationsbewusstsein*. München: BMW AG.
- Prestl, W., Sauer, T., Steinle, J., & Tschernoster, O. (2000). *The BMW Active Cruise Control ACC*. Paper presented at the SAE 2000 World Congress, Detroit, Michigan.
- Rajaonah, B. (2001). *La relation de confiance entre le conducteur et un système automatique de régulation de vitesse*. Paper presented at the Epique 2001, INRIA, Rocquencourt.
- Ranney, T. A. (1994). Models of driving behaviour: a review of their evolution. *Accident Analysis and Prevention*, 26(6), 733-750.
- Rasmussen, J. (1983). Skills, rules and knowledge: Signals, signs and symbols, and other distinctions in human performance models. *IEEE Transactions on Systems, Man, and Cybernetics*(SMC-13), 257-266.
- Rasmussen, J. (1987). The definition of human error and a taxonomy for technical system design. In J. Rasmussen, K. Duncan & J. Leplat (Eds.), *New technology and human error*. Chichester, UK: Wiley.
- Reason, J. (1992). *Human error*. Cambridge, England: Cambridge University Press.
- Reichart, G. (2001). *Menschliche Zuverlässigkeit beim Führen von Kraftfahrzeugen*. PhD Thesis, VDI Verlag, Technische Universität, München.

- Rekersbrink, A. (1994). *Verkehrsflußsimulation mit Hilfe Fuzzy-Logic und einem Konzept potentieller Kollisionszieten*. Universität Karlsruhe, Karlsruhe.
- Richardson, M., Barber, P., King, P., Hoare, E., & Cooper, D. (1997). *Longitudinal driver support systems*. Paper presented at the Autotech '97, London.
- Rickard, T. C. (1999). A CMPL alternative account of practice effects in numerosity judgement tasks. *Journal of Experimental Psychology: Learning, Memory, and Cognition*, 25, 432-442.
- Risser, R., & Lehner, U. (1997). *Evaluation of an ACC (Autonomous Cruise Control) system with the help of behaviour observation*. Paper presented at the Mobility for Everybody - 4th World Congress on Intelligent Transport Systems, Brüssel.
- Roessingh, J. J. M., & Hilburn, B. G. (2000). *The power law of practice in adaptive training applications*. Amsterdam: National Aerospace Laboratory NLR.
- Saad, F., & Villame, T. (1996). *Assessing new driving support systems: contribution of an analysis of drivers' activity in real situations*. Paper presented at the 3rd World Congress On Intelligent Transport Systems, Washington, D.C.
- Salmoni, A. W., Schmidt, R. A., & Walter, C. B. (1984). Knowledge of results and motor learning: a review and critical reappraisal. *Psychological Bulletin*, 95(3), 355-386.
- Scerbo, M. W. (1996). Theoretical Perspectives on Adaptive Automation. In R. a. M. M. Parasuraman (Ed.), *Automation and Human Performance: Theory and Applications* (pp. pp. 37-63). New Jersey: Lawrence Erlbaum Ass.
- Schmidt, R. A., & Lee, T. D. (1999). *Motor control and learning: a behavioural emphasis (3rd ed.)*. Champaign: Human Kinetics.
- Schmidt, R. A., Young, D. S., Swinnen, S. P., & Shapiro, D. C. (1989). Summary knowledge of results for skill acquisition: support for the guidance hypothesis. *Journal of Experimental Psychology: Learning, Memory, and Cognition*, 13(2), 352-359.
- Schroth, M. L. (1997). Effects of frequency of feedback on transfer in concept identification. *American Journal of Psychology*, 110(1), 71-79.
- Schwarz, A., Schiele, P., & Naab, K. (2002). *Enabling Technologies and Architecture requirements for realisation of advanced driver assistance systems*. Paper presented at the ITS World Congress, Chicago.
- Schweitzer, N., Apter, Y., Ben-David, G., Liebermann, D. G., & Parush, A. (1995). A field study on braking responses during driving: minimum driver braking times. *Ergonomics*, 38, 1903-1910.
- Senders, J., & Moray, H. (1991). *Human error: cause, prediction and reduction*. Hillsdale, NJ: Lawrence Erlbaum Associates.

- Shackel, B. (1997). Evaluating user-computer interaction: a framework. *International Journal of Man-Machine Studies*, 38(4), 689-711.
- Sheridan, T. B., & Parasuraman, R. (2000). Human vs. automation in responding to failures: an expected value analysis. *Human Factors*, 42, 403-407.
- Simon, J. H. (2002). *A simulator study on the effect of situation awareness on readiness to brake during ACC driving*. Würzburg: Würzburger Institut für Verkehrswissenschaften.
- Simon, J. H., & Kopf, M. (2001). *Schritte zum lernstufenadaptiven, selbsterklärenden Fahrerassistenzsystem*. Paper presented at the 4. Berliner Werkstatt Mensch-Maschine-Systeme, Berlin.
- Smith, M. R. H., Flach, J. M., Dittman, S. M., & Stanard, T. (2001). Monocular optical constraints on collision control. *Journal of Psychology: Human Perception and Performance*, 27, 395-410.
- Sorkin, R. D. (1987). Design of auditory and tactile displays. In G. Salvendy (Ed.), *Handbook of Human Factors*. New York: John Wiley & Sons.
- Sorkin, R. D., & Kantowitz, B. H. (1987). Speech communication. In G. Salvendy (Ed.), *Handbook of Human Factors* (pp. 295-310). New York: John Wiley & Sons.
- Stanton, N. A., & Baber, C. (1996). Factors affecting the selection of methods and techniques prior to conducting a usability evaluation. In P. W. Jordan, B. Thomas, B. A. Weerdmeester & I. McClelland (Eds.), *Usability Evaluation in Industry* (pp. 39-48). London: Taylor and Francis.
- Stanton, N. A., & Edworthy, J. (1999). Auditory warning affordances. In N. A. Stanton & J. Edworthy (Eds.), *Human Factors in Auditory Warnings*. Hants: Ashgate Publishing Ltd.
- Stanton, N. A., & Marsden, P. (1996). From fly-by-wire to drive-by-wire: safety implications of vehicle automation. *Safety Science*, 24(1), 35-49.
- Stanton, N. A., & Pinto, M. (2000). Behavioural compensation by drivers of a simulator when using a vision enhancement system. *Ergonomics*, 43, 1359-1370.
- Stanton, N. A., & Young, D. S. (2000). A proposed psychological model of driving automation. *Theoretical Issues in Ergonomics Science*, 1(4), 315-331.
- Stanton, N. A., Young, D. S., & NcCaulder, B. (1996). Drive-by-wire: the case of driver workload and reclaiming control with adaptive cruise control. *Safety Science*, 24, 35-49.
- Stanton, N. A., Young, D. S., & NcCaulder, B. (1997). Drive-by-wire: the case of driver workload and reclaiming control with adaptive cruise control. *Safety Science*, 24, 35-49.
- Stanton, N. A., & Young, M. S. (1998). Vehicle automation and driver performance. *Ergonomics*, 41, 1014-1028.

- Stevens, A., Board, A., Allen, P., & Quimby, A. (1999). *A safety checklist for the assessment of in-vehicle information systems: a user's manual*. Project report PA3536/99: Transport Research Laboratory.
- Stokes, A. F., Wickens, C. D., & Kite, K. (1990). Display technology: human factors concepts. *Warrendale, PA: Society of Automotive Engineers*, 31-38.
- Strobl, M. (2003). *SPIDER - Ein innovatives Software-Framework für die Fahrsimulation*. Beitrag zur Tagung: *Simulation und Simulatoren - Mobilität virtuell gestalten*. Paper presented at the Simulation und Simulatoren, Hamburg.
- Strobl, M., Löwenau, J. P., & Bernasch, J. H. (2000). *Generation of complex traffic scenarios in the BMW driving simulator*. Paper presented at the Driving Simulation Conference (DSC), Paris.
- Summala, H. (1988). Risk control is no risk adjustment: the zero-risk theory of driver behaviour and implications. *Ergonomics*, 31(4), 491-506.
- Süß, H.-M. (1996). *Intelligenz, Wissen und Problemlösen. Kognitive Voraussetzungen für erfolgreiches Handeln bei computersimulierten Problemen*. Göttingen: Hogrefe.
- Sviden, O. (1993). MMI scenarios for the future road service informatics. In A. Parkes (Ed.), *Driving future vehicles*. London: Taylor & Francis.
- Swinnen, S. P. (1990). Interpolated activities during the knowledge-of-results delay and post-knowledge of results interval: Effects on performance and learning. *Journal of Experimental Psychology: Learning, Memory, and Cognition*, 16, 692-705.
- Taieb-Maimon, M., & Shinar, D. (2001). Minimum and comfortable driving headways: reality versus perception. *Human Factors*, 43(1), 159-172.
- Törnros, J., Harms, L., & Alm, H. (1997). *The VTI driving simulator - validation studies*. Paper presented at the Driving Simulator Conference (DSC), Lyon.
- Törnros, J., Nilsson, L., Östlund, J., & Kircher, A. (2002). *Effects of ACC in driver behaviour, workload and acceptance in relation to minimum time headway*. Paper presented at the 9th World Congress on Intelligent Transport Systems, Chicago, Illinois.
- Tresilian, J. R. (1991). Empirical and theoretical issues in the perception of time to contact. *Journal of experimental psychology: Human perception and performance*, 17, 865-876.
- Tresilian, J. R. (1995). Perceptual and cognitive processes in time-to-contact estimation: analysis of prediction-motion and relative judgement tasks. *Perception & Psychophysics*, 57, 231-245.
- van der Horst, A. R. A. (1990). *A time-based analysis of road user behaviour in normal and critical encounters*. PhD Thesis, TNO Institute for Perception, Soesterburg, The Netherlands.

- van der Hulst, M. (1999). *Adaptive control of safety margins in driving*. PhD Thesis, University of Groningen, The Netherlands.
- van Winsum, W., & Heino, A. (1996). Choice of time-headway in car-following and the role of time-to-collision information in braking. *Ergonomics*(39), 579-592.
- Verwey, W. B. (1992). *Towards guidelines for in-car information management: driver workload in specific driving situations* (No. IZF C-4). Soesterberg, Netherlands: TNO Institute for perception.
- Verwey, W. B. (1995). Measuring workload peaks while driving. A comparison of nine common workload assessment techniques. *Journal of Experimental Psychology: Applied*, 2, 270-285.
- Vollrath, M., & Totzke, I. (2000). In-vehicle communication and driving: an attempt to overcome their interference, Driver distraction internet forum. from <http://www-nrd.nhtsa.dot.gov/departments/nrd-13/driver-distraction/PDF/33.PDF>
- Von Garrel, U. (2003). *Adaptive Modellierung des fertigkeitbasierten Fahrerverhaltens durch konstruktives und evaluierendes Lernen*, PhD Thesis., Universität der Bundeswehr, München.
- Walker, G. H., Stanton, N. A., & Young, M. S. (2001). Where is computing driving cars? *International Journal of Human-Computer Interaction*, 13(2), pp. 203-229.
- Ward, N. J. (1996). *Interactions with Intelligent Transport Systems (ITS): Effects of task automation and behavioural adaptation*.
- Ward, N. J. (2000). Automation of task processes; an example of intelligent transportation systems. *Human Factors and Ergonomics in Manufacturing*, 10(4), 395-408.
- Wasielewski, P. (1979). Car following headways on freeways interpreted by the semi-Poisson headway distribution model. *Transportation Science*, 13, 36-55.
- Weinberger, M. (2000). *Der Einfluß von Adaptive Cruise Control auf das Fahrerverhalten*. Doktorarbeit, Technische Universität München, München.
- Wickens, C. D. (1992). *Engineering Psychology and Human Performance* (2nd ed.). New York: Harper and Collins.
- Wickens, C. D., & Hollands, J. G. (2000). *Engineering Psychology and Human Performance* (Third ed.). Upper Saddle River, N.J.: Prentice Hall.
- Wilde, G. J. S. (1994). Risk Homeostasis Theory And Its Promise For Improved Safety. In R. Trimpop & G. J. S. Wilde (Eds.), *Challenges To Accident Prevention: The issue of risk compensation behaviour*. Groningen: STYX-Publications.
- Williams, M. D., Hollan, J. D., & Stevens, A. L. (1983). Human reasoning about a simple physical system. In D. Gentner & A. L. Stevens (Eds.), *Mental Models* (pp. 131-153). Hillsdale, NJ: Lawrence Erlbaum.

- Winner, H., Witte, S., Uhler, W., & Lichtenberg, B. (1996). Adaptive Cruise Control system. Aspects and development trends. *SAE Technical Paper Series, 961010*, 27-36.
- Wooldridge, M., Bauer, K., Green, P., & Fitzpatrick, K. (2000). *Comparison of driver visual demand in test track, simulator and on-road environments*. Paper presented at the 79th Annual Meeting of the Transportation Research Board, Washington D.C.
- Yilmaz, E. H., & Warren, W. H. (1995). Visual control of braking: a test of the tau hypothesis. *Journal of Comparative Neurology and Psychology, 18*(459-482).
- Young, M. S., & Stanton, N. A. (1997). Automotive automation: investigating the impact on drivers' mental workload. *International Journal of Cognitive Ergonomics, 1*(4), 325-336.

9 APPENDIX

9.1 Appendix A. Interview and questionnaire in the long-term field study

Allgemeines Verhalten zu technischen Systemen

Sind Sie ein technische orientierter Mensch?

VP.2: Mäßig

VP.3: *Ich möchte Technik nutzen, mich aber mit dem technischen Hintergrund nicht befassen*

VP.5: *Ja, Physiker von Beruf*

VP.6: *Prinzipiell schon*

Wie fühlen Sie sich bei der Nutzung von technischen Sachen? (SMS, VCR etc.)

VP.2: *Durchschnittlich*

VP.3: *Ich lebe leichter mit mehr Freude und mehr Lebensqualität'. Ich vertraue der Technik*

VP.3: *Ich bin nicht Sklave der Technik. Ich möchte eine kurze Einleitung lesen aber nicht studieren.*

VP.5: *Durchschnittlich*

VP.6: *Ich bin schon an technischen Dingen interessiert. Mich interessiert aber mehr, wie es funktioniert und nicht warum es so funktioniert.*

Absichten, Erwartungen an das System vor dessen Verwendung

Wie haben Sie den Funktionsumfang/ Grenzen des Systems getestet?

VP.2: *Ich habe nicht gezielt Situationen herbeigeführt (z.B. Heranfahen an vorausfahrende Fahrzeuge), um die Wirkung des ACC-Systems zu testen. Für mich war praktisch der ganze Fahrversuch Testphase. Die Fahrten waren für mich überwiegend nicht aus irgendwelchen Verpflichtungen notwendig, sondern „just for fun!“, z.B. um Freunde zu besuchen. Ich habe das System zu Beginn am meisten getestet, aber nicht in Extremsituationen.*

VP.3: *Ich habe während der Fahrt probiert wie das System geht. Is Abstand ist viel zu kurz, weil ich schnell fahre. Mit 1,9s Abstand habe ich mich nicht nah genug gefühlt. Im Kurven wusste ich, wo die Grenzen liegen.*

VP.6: *Ich bin ganz normal gefahren und habe geguckt wie das System reagiert. Das Klassische ist der Stau Änderung, bzw. die Verkehrsänderung (stehende Objekte) und Kurvenfahren in der Kolonne. Das Problem ist, dass man durch solche System ein bisschen ‚eindudelt‘ und gar nicht mehr aufmerksam ist. Man weiß nicht wie stark brems das Auto vor mir...und dann stellt man irgendwie fest, was das Sytem kann und*

kann nichts tun. Dann benutzt man das System weniger und dann es ist eigentlich ganz gut.

Was waren die größten Lernhindernisse für Sie, um die optimale Nutzung des ACC zu erreichen? Wie entwickelten sich diese im Verlauf der Zeit? (was waren die größten am Anfang, Mitte, am Ende...)

VP.2: Umstellung auf ein anderes, fremdes (größer als das eigene) Fahrzeug, die jedoch sehr schnell (schon mit der Gewöhnungsphase) bewältigt war. Habe erst nach einiger Zeit bemerkt, dass man mit den Wunschgeschwindigkeit-Tasten auch „bremsen“ kann.

VP.3: Nutzung gut zu Verstehen gewesen, am schwierigsten waren die Grenzen des Systems zu verstehen.

VP.6: Es war relativ einfach aber ich weiß nicht ob ich alle Funktionen benutzt habe von diesem System. ‚Schwer‘ ist vielleicht nicht das richtige Wort, manche Situationen haben mich gestört, aber ich habe es nicht schwer gefunden.

Vertrauen

Wie veränderte sich Ihr Vertrauen gegenüber des Systems im Verlauf der Zeit?

VP.2: Vertrauen in das ACC-System nahm im Verlauf des Versuchs zu; „stieg im Lauf der Zeit“

VP.3: Mit 1,6s Abstand habe ich total Vertrauen in das System. Am Anfang war ich aufmerksamer und am Ende weniger. Vertrauen stieg im Zusammenhang mit der Nutzungshäufigkeit des Systems.

VP.5: Vertrauen in das ACC-System stieg im Lauf der Zeit

VP.6: Vertrauen im Zusammenhang mit Interesse für das System. Am Anfang fand ich es sehr spannend, dann fand ich es nervig weil ich es zu viel benutzt habe, wobei ich das Vertrauen verloren habe.

Motivation

In welcher Versuchsphase haben Sie das System genutzt um es auszuprobieren? (vor allem Grenzen, Möglichkeiten...)

VP.2: Alle Funktionen am Anfang, dann gar nicht mehr! Ich habe alles so gelassen! In den ersten 2-3 Tagen.

VP.3: Ich habe nur am Anfang, die ersten 4-5 Tage, das System intensiv probiert. Im ersten Streckendrittel habe ich das System viel getestet. Im zweiten Drittel habe ich das System vergessen. Im letzten Drittel hab ich mich erinnert, dass ich das System testen soll!

VP.5: „Am Anfang habe ich das System stärker genutzt, in der mittleren Phase war ich ein bisschen im Stress und hatte kürzere Strecken. Dann hatte ich viele Autobahnstrecken und zum Schluss habe ich das System öfter benutzt.“

VP.6: 2-3 Tage ‚Spielzeit‘ wo ich relativ viel gefahren bin. Dann war das im Prinzip so, dass ich damit vertraut war. Es war sehr einfach zu handeln und ich glaube nicht, dass es so lange gedauert hat.

In welcher Versuchsphase haben Sie das System so genutzt, wie wenn Sie das System in Ihrem Privatwagen hätten?

VP.2: Nach 3-4 Tagen.

VP.3: Nach der Versuchsphase habe ich es benutzt wie mein eigenem Auto, also im letzten Drittel.

VP.5: Im letzten Drittel, mit steigender Routine.

VP.6: Gegen Ende, im letzten Drittel. Wobei ich trotzdem glaube, dass ich es deutlich weniger benutzt hätte, wenn es mein Privatwagen wäre.

Explizites Wissen

War Ihnen stets bewusst, in welchem Zustand das System war? Beispielsweise: vorausfahrendes Fahrzeug erkannt, Bremsaktion eingeleitet...

VP.2: Ja. Ich habe das ACC häufig auch eingesetzt, um vorausschauend die Geschwindigkeit zu reduzieren. Ein wesentlicher Aspekt war für mich dabei Treibstoff zu sparen.

VP.3: Ja, das habe ich gewusst... das habe ich gemerkt. Dass es eingeschaltet war, war klar durch diese LED's.

VP.5: Ich war sicher nicht so konzentriert auf das ACC-System, dass ich immer wusste, welchen Abstand ich jetzt eingeschaltet hatte. Ich habe immer den mittleren Abstand genutzt. Ob es eingeschaltet war oder nicht – das wusste ich schon.

VP.6: Das glaube ich schon. Ich fand es relativ einfach zu bedienen. Ich wollte in absehbaren Situationen, in denen das vorfahrende Auto wieder verschwindet, so schnell bleiben wie ich war und auch nicht bremsen. Außerdem wollte ich das ACC unter 30km/h auch nicht nutzen, deswegen habe ich es dann ausgeschaltet: I/O-Schalter am Multifunktionslenkrad).“

Wussten Sie stets, ob sich das System im dem von Ihnen gewünschten Zustand befand?

VP.2: Ja.

VP.3: War OK, klar.

VP.5: Das habe ich nicht immer überprüft.

VP.6: Es ist mir nie bewusst geworden, dass ich dachte... Oops! Ich wollte etwas ganz anderes. Es sind wirklich einzelne Situationen aus denen man quasi gelernt hat und dann gesagt hat: OK, dann muss ich darauf achten (z.B. Auto von anderer Straße erfasst oder in Kurven).

Sicherheit

Wie schwer, oder leicht fiel Ihnen die Entscheidung, bei aktiviertem ACC zu bremsen?

VP.2: Kein Problem, da ich immer einen ausreichenden Abstand einhielt und so ausreichend Zeit für das Eingreifen blieb „;immer relativ einfach!“ Ich war sehr aufmerksam und es war OK. In der Testphase habe ich probiert. Dann es war klar wie das System reagiert soll.

VP.5: Leicht.

VP.6: Am Anfang habe ich das System getestet und habe das ACC bremsen lassen. Ich habe mich aber eher auf mich verlassen als auf das System. Also in sofern denke ich hatte mein Bremsgefühl Vorrang vor ACC. Also ich habe nicht überlegt, ob das System im Recht ist oder nicht - ich habe einfach gebremst. Man hat im Prinzip gelernt wie man Abstände einschätzen muss.

In welchen Situationen war es für Sie besonders schwer zu entscheiden, ob Sie bremsen müssen oder ob die Bremswirkung des ACC ausreicht?

VP.2: Beim Durchfahren einer großen Kurve.

VP.3: Bei 1s Abstand und in den ersten drei Tagen war es am schwierigsten. Dann hatte ich gewusst: 1sec Abstand weg lassen – viel zu gefährlich!

VP.5: In Kurven und beim Auffahren auf langsame LKWs.

VP.6: Kurven, stehendes Auto (Stauende bei einer Ampel), Ausscheren von anderen Fahrzeugen.

Konnten Sie vorhersagen, wie das System funktionieren würde? z.B. welche Objekte entdeckt werden, welche Situationen das System beherrschen kann ... Wenn ja, wie lang brauchten Sie dafür, die Systemreaktionen einzuschätzen?

VP.2: Ja, nach 4 Tagen.

VP.3: Linke Kurven mit LKW an der rechten Seite waren schwierige Situationen. Nach 10 Tagen – war vielleicht der Grund warum ich am Ende das System nicht mehr eingeschaltet habe – war mir klar, was das System macht!

VP.5: Fast immer, nur diese Situationen machen Probleme: Kurven, stehende Objekte, Einscheren. Am Ende konnte man schon vorher das System ausschalten, weil man keine Lust hatte, dass es überdimensional Gas gibt obwohl es sinnlos ist. Aber am Anfang wusste man es natürlich nicht. 3-4 Tage.

VP.6: Kontinuierlich nach etwa 3-4 Tagen.

Komfort

Was hat Ihren Komfort beim Fahren mit ACC beeinflusst?

VP.2: Es war sehr angenehm, den rechten Fuß vom Gas nehmen zu können.

VP.2: Weniger Ermüdung bei längerer Fahrt mit dem ACC als ohne (längere Fahrten allerdings selten durchgeführt).

VP.3: *Wenn ich telefoniere kann ich mich nicht um ACC kümmern. Ich muss mich um den Verkehr kümmern und muss schauen wie das ACC reagiert. Und es könnte schon sein, dass wenn ACC läuft ich weniger telefonieren und andere Sachen machen kann. Ich muss aktiv dabei sein! Ich benutze das Telefon oder das ACC-System. Ich benutze das Telefon mehr ohne ACC...*

VP.5: *Man kann über längere Strecken sich mehr entspannen.*

VP.6: *Komfort wurde gesteigert! Man hat mehr Zeit für andere Sachen... aber ich bin kein Freund davon, so viel anderes zu tun, weil ich der Meinung bin, dass meine Unfallgefahr mit ACC deutlich höher ist, weil meine Aufmerksamkeit nicht ständig auf der Straße ist. Ich glaube das ist der Sicherheit nicht dienlich, dem Komfort sehr wohl.*

Hat ACC Ihnen ein zu hohes Komfortgefühl vermittelt? z.B. Aufmerksamkeit, Benutzung von Radio...

VP.2: *Das ACC hat grundsätzlich das Komfortempfinden erhöht. Es hat aber nicht zu verminderter Aufmerksamkeit oder zu Ermüdung geführt, weil ich darauf eingestellt war, das System aktiv auszuprobieren. Eher kein Problem, höchstens wenn man sehr lange mit dem System fährt. Man merkt ja, wenn das System bremst, dann kann man entscheiden, ob es das System selbst handhaben kann.*

VP.5: *Also zum damaligen Zeitpunkt nicht, weil ich meine, dass es nicht ausgereift war. Es hat mir kein hohes Komfortgefühl vermittelt, weil ich zu konzentriert war.*

Wie setzten Sie das ACC-System bei schlechter Sicht und Nässe ein?

VP.2: *Eigentlich wie sonst auch, jedoch eventuell mit größerem Abstand und geringerer Geschwindigkeit.*

VP.3: *Weniger einsetzen / eher größerer Abstand.*

VP.5: *Gar nicht – weil in der Anleitung steht, dass man es bei Nässe und Schnee nicht einsetzen soll!*

VP.6: *Ich denke ich habe es nicht bei Nacht genutzt (450km!) und auch nicht bei Regen (100km!).*

Fanden Sie, dass der Fahrstil des ACC-Systems Ihrem eigenen Fahrstil entspricht? Warum?

VP.2: *In etwa ja. Es war ja immer möglich, das ACC an den eigenen Fahrstil anzupassen, durch Einstellen des Abstandes, Setzen der Geschwindigkeit ...*

VP.3: *Mit 1,6s Abstand, ja. Das Bremsen – ja, das war OK.*

VP.3: *Das System beschleunigt zu langsam – deshalb habe ich häufig durch das Gaspedal eingegriffen.*

VP.5: *„Ich brems anders, ich fahre anders... Es repräsentiert nicht meinen Fahrstil mit meinem PkW“.*

VP.6: Nein, es hat viel zu viel gebremst. Es bremst anders als ein normaler Fahrer.

Bedürfnisse nach zusätzlicher Information

Hatten Sie irgendwelche Fragen zu dem System während Ihrer Fahrt mit ACC?

Vp.2: Nein, es war vor dem Versuch ausreichend erklärt worden.

Vp.3: 2-3 mal hat das System nicht reagiert wie es sollte.

Vp.5: Alle 3 Tage habe ich mit dem Versuchsleiter diskutiert.

Vp.6: Wir hatten eine Notfall Nummer.

Wie würden Sie sich generell die Einführung eines solchen Systems wünschen?

Vp.2: Es wäre sehr hilfreich (eigentlich unverzichtbar), wenn jemand das System persönlich erklärt. Die Benutzung des ACC-Systems ohne Einführung (nur anhand einer Bedienungsanleitung) zu lernen, wäre wahrscheinlich sehr problematisch gewesen.

Vp.3: ,ACC Service (Not)-Nummer. Der Hintergrund: Leute müssen wissen, wie es funktioniert.

Vp.5: Eine Stunde, vielleicht zwei mit dem Händler das System ausprobieren. Er sollte mir erklären, was ich falsch mache. Aber am besten ist, das Auto für ein paar Tage zu testen, um das System auf Landstraßen und Autobahnen auszuprobieren.

Vp.6: Am liebsten hätte ich, dass es mir jemand erklärt.

Denken Sie dass eine ,Online' Hilfe nützlich wäre? (auf Nachfrage zunächst Erklärung durch Interviewer, was darunter zu verstehen ist)

Vp.2: Wäre schon nützlich, müsste aber von Anfang an zur Verfügung stehen.

Vp.2: Ja, hilfreich, wenn keine visuelle Aufmerksamkeit nötig.

Vp.3: Mit Sicherheit nicht schlecht – mit Bildschirm und Sprachausgabe. Könnte mir ein Funktionsbeispiel zur Erklärung gut vorstellen.

Vp.5: Per I/O Sprache. Super! Habe ich noch nie gehört – wäre toll! Das System sagt was möglich ist (kurze, verständliche Erklärungen) und das System kann auch Fragen beantworten.

Vp.6: Ja, aber nicht nur für ACC, wenn alles drin ist denk ich ja.

9.2 Appendix B. Instructions and questionnaire in the tutor system study

Beside the instructions administered to drivers for the respective drives that were identical for both experimental groups, drivers received instructions about the ACC system which explains the basic system functionalities, the operational procedures and warns of potential system limits. Drivers in the tutor group were additionally given instructions on the tutor system's purpose and use.

Instructions to drivers in the tutor group

Anweisung zum ACC-Fahrerassistenzsystem und zum Versuchsablauf.

ACC Prinzip

Ein ACC-System (ACC = Adaptive Cruise Control) unterstützt den Fahrer bei der Längsregelung (Geschwindigkeits- und Abstandsregelung). Basierend auf dem Grundprinzip eines herkömmlichen Geschwindigkeitsreglers (Tempomat) können Sie Ihre Wunschgeschwindigkeit eingeben, auf die das System dann regelt. Falls ein Auto vor Ihnen fährt oder auch einschert, hält das System automatisch den Abstand ein.

ACC Bedienung

Die Bedienung des ACC erfolgt über rechts im Multifunktions-Lenkrad (MFL) angebrachte Tasten (Abbildung 1). Mit der I/O-Taste rechts am Lenkrad ist das ACC bereit. Danach müssen Sie entweder die ACC-Symbol-Taste (sog. „Speicherabruf-Taste“) rechts oben am Lenkrad oder die +/- Tasten drücken, um mit aktivem ACC zu fahren. Bei Betätigung der unteren ACC-Taste („I/O“) wird das ACC sofort ausgeschaltet. Darüber hinaus schaltet sich das ACC selbsttätig aus, wenn:

- das Bremspedal betätigt wird.
- der Motor ausgeschaltet ist.
- die gefahrene Geschwindigkeit unter 30km/h fällt.



Abbildung 1: ACC-Bedienelemente im Multifunktions-Lenkrad (MFL)

Bei diesem Versuch geht es darum, dass Sie das Fahren mit einem Abstandregelungssystem, sog. „ACC-System“ (Active Cruise Control) kennen lernen. Um die lange, manchmal gefährliche Lernphase eines neuen Fahrerassistenzsystems, wie das ACC-System, zu verringern, wird in diesem Versuch ein „Selbsterklärendes ACC-System“, das über Sprachausgabe und visuelle Anzeigen Hinweise und Erklärungen zur Funktionsweise des ACC-Systems in der aktuellen Verkehrssituation gibt, getestet. Die Hinweise und Erklärungen werden entsprechend Ihrer Bedieneingabe, der aktuellen Verkehrssituation und natürlich Ihrer Systemerfahrung ermittelt.

Ausschaltung von Hinweisen und Erklärungen:

Sie können, wenn das gelbe „i“ im Kombiinstrument leuchtet, direkt nach den akustischen Hinweisen „später“ sagen. Ihre Aussage wird von der Spracherkennung dann aufgenommen, der akustische Hinweis wird abgebrochen und zu einem späteren Zeitpunkt (in der gleichen Situation) wieder auftreten. Sobald Sie meinen, einen Hinweis oft genug gehört und die Information auch verstanden zu haben, können Sie diese Aussage mit dem „i“ (Information) - Knopf im Lenkrad (siehe Abbildung 1) abschalten. Sie wird dann nicht mehr auftreten. Sie haben auch die Möglichkeit, jede Aussage wiederholen zu lassen. Hierzu teilen Sie dem System einfach nur das Wort „Wiederholen“ mit. Die letzte Aussage wird dann wiederholt.

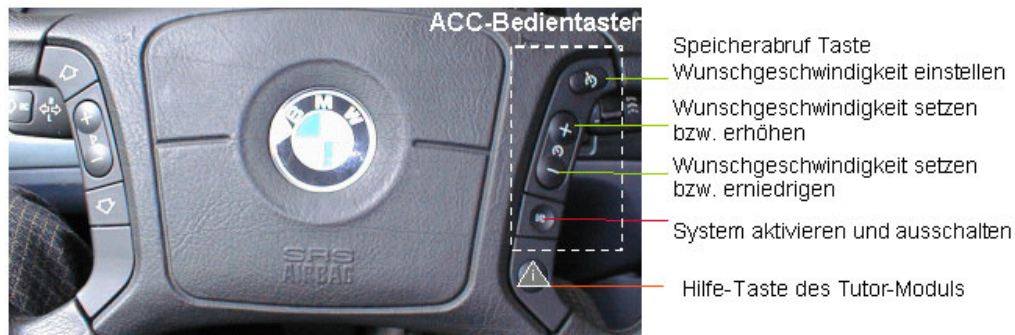
Ihr persönlicher Lernzustand wird auf einer personalisierten Karte registriert und nach jeder Fahrt aktualisiert.

Fahrtablauf

Sie werden auf einer abwechslungsreichen Strecke fahren, in dichtem und weniger dichtem Verkehr, auf der Landstrasse und auf der Autobahn. Bei allen Fahrten sollten Sie darauf achten, keine Fahrfehler zu begehen. Die Straßenverkehrsordnung gilt in vollem Umfang.

Instructions to drivers in the standard group

Anweisung zum ACC-Fahrerassistenzsystem und zum Versuchsablauf.

ACC Prinzip

Ein ACC-System (ACC = Adaptive Cruise Control) unterstützt den Fahrer bei der Längsregelung (Geschwindigkeits- und Abstandsregelung). Basierend auf dem Grundprinzip eines herkömmlichen Geschwindigkeitsreglers (Tempomat) können Sie Ihre Wunschgeschwindigkeit eingeben, auf die das System dann regelt. Falls ein Auto vor Ihnen fährt oder auch einschert, hält das System automatisch den Abstand ein.

ACC Bedienung

Die Bedienung des ACC erfolgt über rechts im Multifunktions-Lenkrad (MFL) angebrachte Tasten (Abbildung 1). Mit der I/O-Taste rechts am Lenkrad ist das ACC bereit. Danach müssen Sie entweder die ACC-Symbol-Taste (sog. „Speicherabruf-Taste“) rechts oben am Lenkrad oder die +/- Tasten drücken, um mit aktivem ACC zu fahren. Bei Betätigung der unteren ACC-Taste („I/O“) wird das ACC sofort ausgeschaltet. Darüber hinaus schaltet sich das ACC selbsttätig aus, wenn:

das Bremspedal betätigt wird

der Motor ausgeschaltet ist

die gefahrene Geschwindigkeit unter 30km/h fällt



Abbildung 1: ACC-Bedienelemente im Multifunktions-Lenkrad (MFL)

Bei diesem Versuch geht es darum, dass Sie das Fahren mit einem Abstandregelungssystem, sog. „ACC-System“ (Active Cruise Control) kennen lernen.

9.3 Appendix C. Situation detection conditions in the tutor system study

In the following two tables, the conditions necessary for the real time detection of traffic situations by the situation detection module are described. The situations in table 2 represent the critical traffic situations in which an intervention is necessary to avoid the danger of an accident. All situations were detected in real-time. Upon detection, the corresponding feedback was emitted. The detection of the below mentioned situations was entirely based upon real data and therefore could be implemented into a vehicle in real conditions.

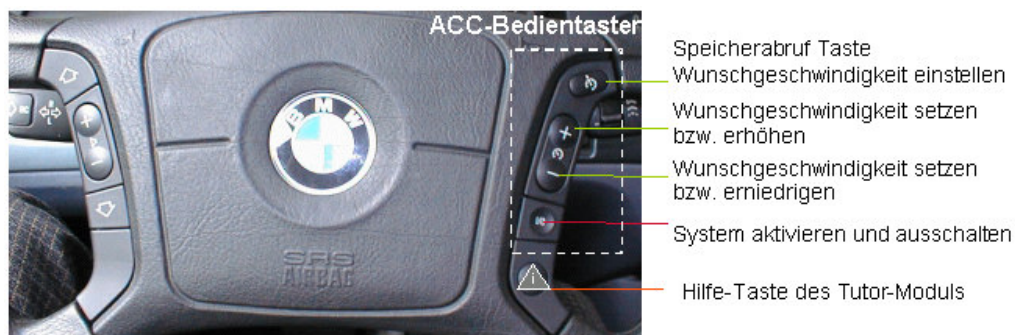
Table 1 C. *Conditions for the real time detection of traffic situations*

Conditions necessary for the detection of a cut-in situation:

Upon first detection of the lead car, the minimal measured distance to it must be smaller than the baseline sensor range measurement. The parameter „ACC radar sensor range“ for the detection of situations in which the system limits will be reached was for this simulator study set to 120m, and the minimal distance for the detection of a cut-in situation was set to 80m. In tight curves, there is the possibility that the radar sensors did not detect the lead car with a 120m distance and would, on this basis, assume that the detected situation is a cut-in situation. To prevent this from occurring, the lane number of lanes is checked. If the road has more than one lane, it can be deduced with relative certainty that the situation at hand is really a cut-in situation as on multi-lane roads, it is very unlikely that similar tight curves will occur. Although in real traffic, ‘lane detectors’ to calculate the number of lanes have not yet been implemented, the situation could also be predicted through a calculation of the ‘detectable distance’. This might be achieved by calculating the maximum distance, using the steering angle and the angle of the radar sensors, that the lead vehicle could have for it to be detected if it was straight ahead. If this distance is greater than the baseline measurement for the detection of a cut-in situation, then it can be assumed that the situation is really a cut-in situation. As this was the first prototype of a tutor system and the testing was conducted in a simulated environment, the easiest method to detect the number of lanes was opted for.

To confirm the occurrence of a cut-in situation, the ‘necessary deceleration’ was also checked in order to confirm the approach to the lead vehicle. Further, to make sure that no ‘wrong objects’ are detected, it was verified that the detected vehicle is in the ACC vehicle’s lane. This possibility does not yet exist in real traffic, however, a ‘wrong object detection’ seldom occurs. When all these conditions are successfully met, a cut-in situation is recognised by the Info-system.

At the same time, the system will determine whether the capabilities of the ACC system will suffice to handle the detected cut-in situation. This is determined by the so-called ‘brake

parameter'. Like the situation number it is also measured every 10ms and is linked directly to the issuing of the appropriate informatory sound samples. During the warning of the presence of such a situation, two values can be administered:

Brake parameter = 0: No feedback is given about the system capabilities

Brake parameter = 1: System capabilities can handle the longitudinal control

Conditions necessary for the detection of approach situations with a high relative velocity:

The relative velocity by detection of the lead car must be greater than 15m/s. Other than that, the necessary deceleration is checked as well as whether the detected vehicle is on the same lane as the ACC vehicle. Also here, the brake parameter will be determined according to the necessary deceleration.

Conditions necessary for the detection of a hard braking lead vehicle:

For the detection of this situation, the acceleration of the lead car is the most important variable. If the basis value of 2.3m/s^2 remains above this acceleration rate for a certain time period, the existence of this situation is signalled. Thereafter, the brake parameter will be set according to the necessary rate of deceleration.

Conditions necessary for the detection of a lead vehicle leaving the detected radar range in a curve:

Firstly, the fact that the vehicle has come out of the radar range must be confirmed. This is effectuated by the calculation of the distance to the lead vehicle. If the value changes from a value above 0 to the value 0, then the lead vehicle was no longer detected. Further, if the value of the steering wheel angle exceeds a set and tested limit during a determined time period, the conditions for the detection of this situation are fulfilled.

Conditions necessary for the detection of an approach to a very slow vehicle:

If the speed of the lead vehicle is less than 3m/s but greater than 0m/s, this situation is detected.

Conditions necessary for the detection of an unnecessary braking intervention:

If the value of the brake pedal is greater than 0, the status of the ACC system changes from 2 to 255 (active status to system de-activated status) and the acceleration rate of the lead car decreases in a stable manor and none of the abovementioned have been detected then an unnecessary braking intervention during slight changes in the lead vehicles' speed is signalled. Further, the necessary deceleration rate is checked for which the absolute value of the deceleration must be smaller than the offset value.

Conditions necessary for the detection of a drive through a tight curve without ‘loss’ of the detected vehicle:

The conditions for the detection of this situation are similar to the conditions for situation 16. The lead vehicle does not come out of the radar sensor range therefore, the detected distance must have a value above 0. The curve will be determined from the steering wheel angle.

Table 2 C. *Conditions for the real time detection of critical traffic situations*

Conditions necessary for the detection of a driver intervention in a tight curve in which the lead vehicle came out of the detectable radar range.

If the situation with the number 16 is detected (warning of a tight curve with object out of radar range) and the driver has applied the brakes, this situation is signalled.

Conditions necessary for the detection of an imminent automatic switching off of the ACC system due to the lead car driving at a speed below 30km/h:

If the speed of the lead vehicle is lower than 8.4m/s but greater than 0m/s, if it is on the same lane and if the situation with the number 17 has not been detected, then it is recognised that the ACC system will automatically switch itself off as soon as a speed below 30km/h is reached.

Conditions necessary for the detection of a driver intervention after a cut-in situation:

Here, the necessity of the driver intervention will be established. On the basis of the calculated necessary deceleration, the so-called brake parameter will be determined. Two values are administered:

Brake parameter = 1: Longitudinal control could have been effectuated by the ACC

Brake parameter = 2: Driver intervention was necessary

After a driver intervention in a cut-in situation, it is checked whether before the intervention the situation with the number 13 was detected and the brake pedal applied. After which, the classification of the brake parameter is determined. If the absolute value of the necessary deceleration is smaller than 1.9m/s^2 , the system could have handled the situation and the brake parameter 1 is set. If the absolute value of the necessary deceleration was greater than 1.9m/s^2 , the brake parameter is set to 2 and the corresponding reinforcing feedback is emitted.

Conditions necessary for the detection of a driver intervention after an approach to a lead car with a high relative velocity:

For this situation, the brake parameter was also classified into necessary and unnecessary interventions. By an absolute value of 1.9m/s^2 , the brake parameter will be attributed the value 1, otherwise it will attributed the value 2. Further, the situation with the number 14 must have been detected as well as the application of the brake pedal.

Conditions necessary for the detection of a driver intervention by a hard braking of the lead car:

For the detection of this situation, the situation with the number 15 must be detected as well as the application of the brake pedal. Here too, drivers' interventions are classified into necessary and unnecessary interventions. A necessary deceleration value below 1.7m/s^2 will attribute the brake parameter with the number 1. A value above 1.7m/s^2 will be attributed the number 2.

In order to gain a certain level of situation-stability, so-called 'stability time periods' were implemented. Their length differed in regards to the corresponding type of feedback. The feedback corresponding to detected situations which belong to the 'operation of the system' or to the 'use of the system in difficult or potentially dangerous environmental conditions' help categories, is immediately issued. However, after the detection of a situation in the 'functional principal' category, a stability time period of one second is introduced. If, after this time period the situation remains detected, the corresponding feedback will be emitted.

Upon the detection of a situation belonging to the 'system limits' help category, the corresponding feedback is emitted after a three second time period if the situation is still detected and no other situation has been signalled. An exception in this category is in the case of the detection of the lead vehicle's speed reaching a speed below 30km/h , when the system switches itself automatically. This situation is detected a-priori and the corresponding feedback is issued immediately. Through the implementation of these stability time periods, a short-term incorrect detection is avoided and a high output of the same speech output in a particular traffic situation is reduced.

9.4 Appendix D. Instructions and questionnaire in the warning system study

Appendix D has been divided into three parts. First, the scenarios programmed for the first and second lap of experimental drive 1 are shown. The order of the scenarios in the first and second lap of the second experimental drive differed from the first experimental drive but the scenarios were the same. The different colours display the different motorway segments.

Second, the instructions administered to each group. The instructions regarding the drives were identical in both groups, only the information regarding the display differed. Third, the questionnaires administered to both groups after each drive, with the analysis of drivers' answers that were not included in section 5.3.

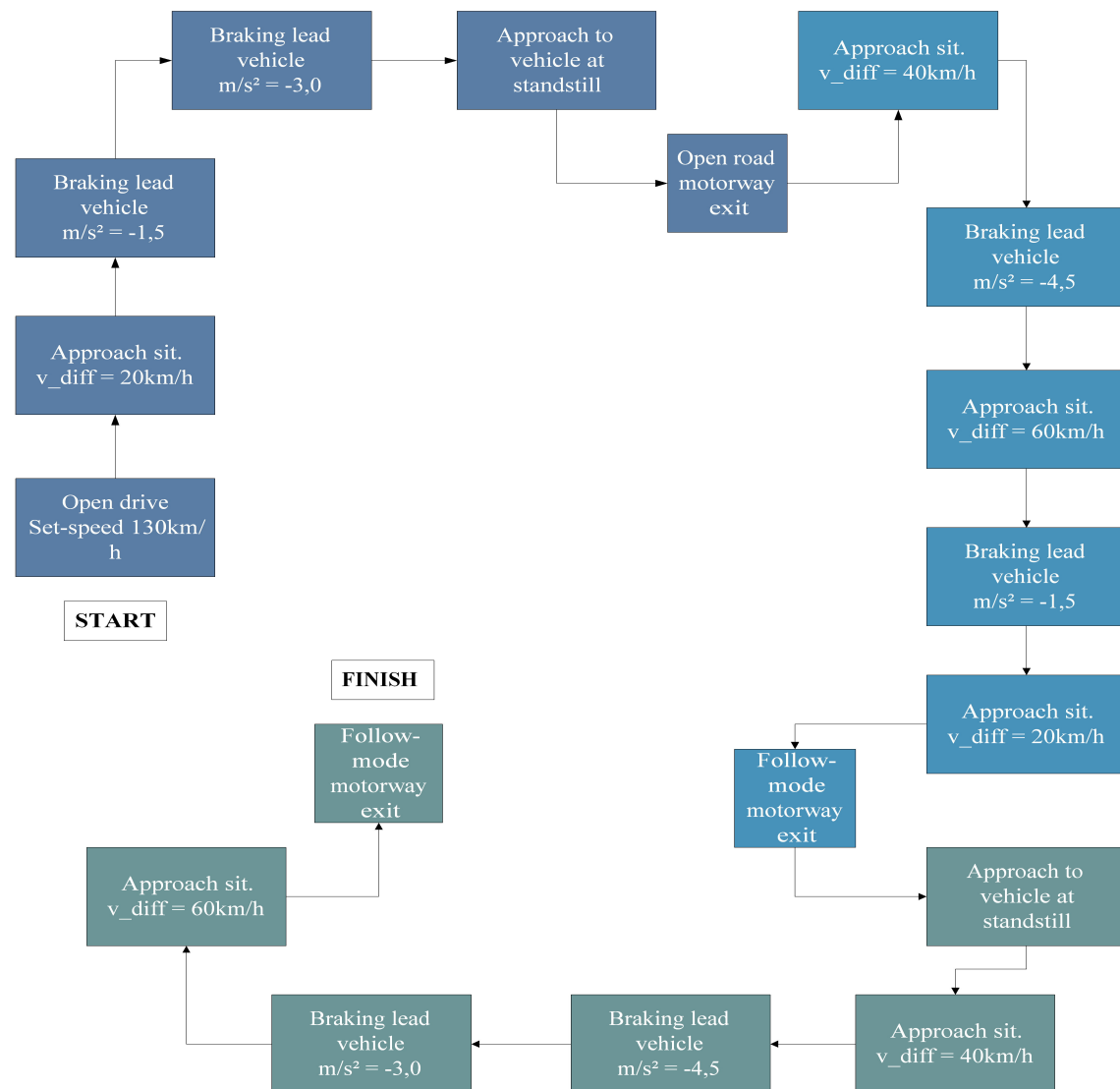

The scenarios of the first lap of experimental drive 1.

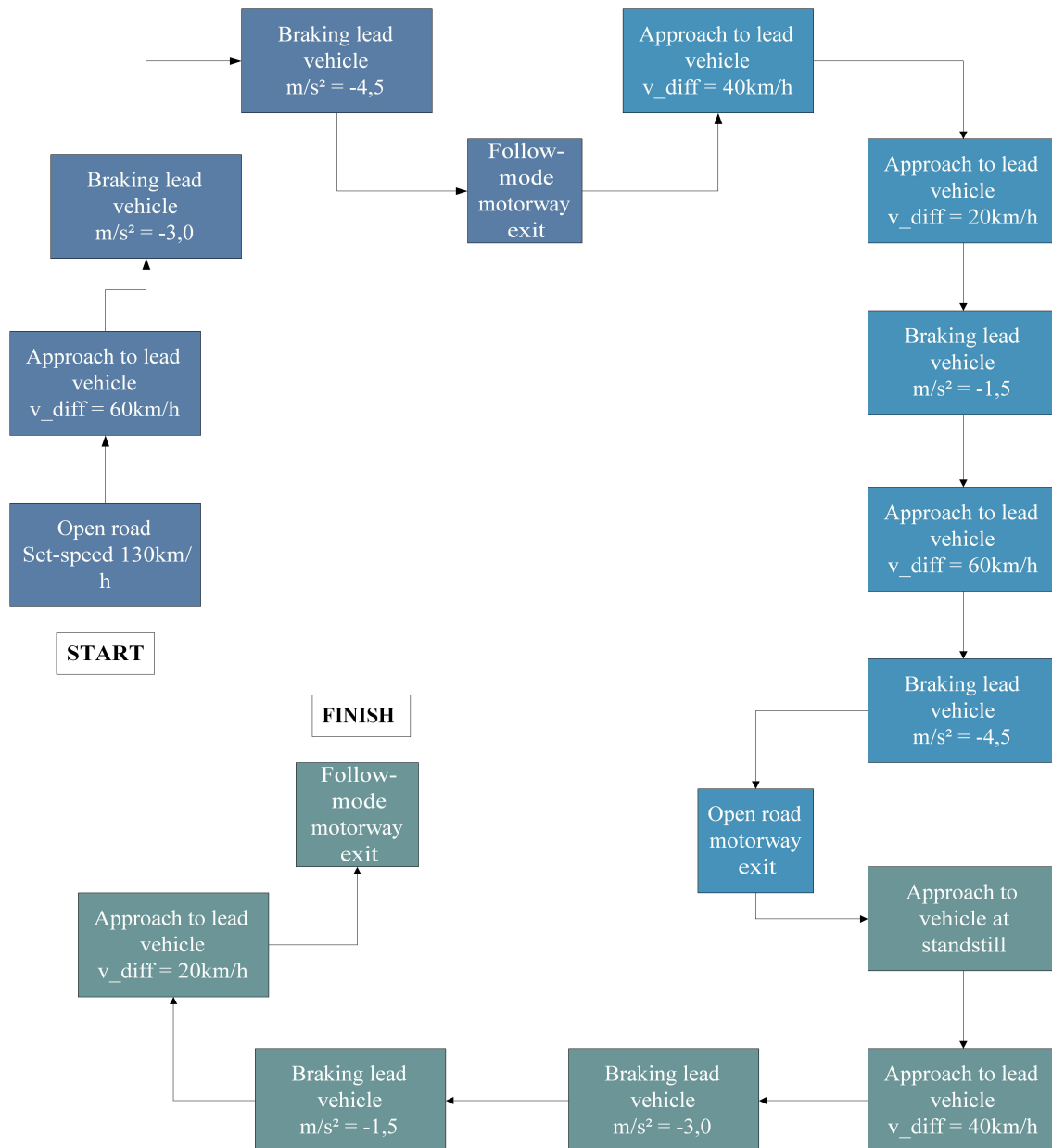

The scenarios of the second lap of experimental drive 1.

The following section includes the instructions and the administered questionnaire for each drive in the standard group. The order in which the instructions are listed represents the order in which they were administered to the participants. The questionnaire was administered to participants after each experimental drive.

Anweisung für Eingewöhnungsfahrt:

Bei der nun folgenden Eingewöhnungsfahrt werden Sie zunächst eine Weile frei fahren können. Bitte beschleunigen nach der Autobahnauffahrt auf 120km/h und verändern Sie diese in Intervallen im Bereich zwischen 80 und 150km/h. Dazu sollten Sie unterschiedliche Bremsstärken ausprobieren.

Versuchen Sie ein Gefühl für das Fahren im Simulator zu erhalten.

Nach ein paar Minuten treffen Sie auf ein anderes Fahrzeug. Folgen dann Sie bitte diesem Fahrzeug (nicht überholen!). Das vorausfahrenden Fahrzeug wird seine Geschwindigkeit in Intervallen im Bereich zwischen 80 und 150km/h verändern.

Während der Fahrt achten Sie bitte auf folgende Punkte:

Immer nach einem stehenden LKW die nächstmögliche Abfahrt benutzen.

Sie dürfen **nicht** Überholen! Fährt vor Ihnen ein langsamere Fahrzeug, so sollte diesem hinterhergefahren werden (d.h. nicht überholen; nicht auf eine andere Spur fahren).

Ihre Aufgabe ist es, die Strecke ohne Fahrfehler zu bewältigen. Als Fahrfehler gelten (wie im realen Verkehr auch):

- Abkommen von der Fahrbahn
- Schlechte Spurhaltung oder Schleudern
- Kollisionen mit Fahrzeugen, Fußgängern oder Objekten

Zusätzliche Aufgabe

Zusätzlich wird Ihre Reaktionszeit gemessen. Ein eingeblendetes schwarz-rotes Viereck wird links oder rechts in der Simulation auftreten. Wenn Sie es sehen, sollten Sie es mit der Blinker bestätigen. Bitte bestätigen Sie den Blinker während des gesamten Versuchs nur für die Bestätigung des Reizes.

Taucht der Reiz rechts auf, bestätigen Sie bitte den rechten Blinker. Für den linken Reiz benutzen Sie bitte den linken Blinker. Der Reiz wird 2s gezeigt, danach wird er verschwinden. Sie sollten so schnell wie möglich durch ein kurzes Antippen des Blinkers (Einrasten ist nicht erforderlich) bestätigen.

Die Fahrt dauert ca. 20 Minuten.

Anweisungen für Kalibrierungsfahrt

Im Rahmen dieser Untersuchung sollen Fahrdaten aufgenommen werden mit der Zielsetzung verschiedene Parameter des BMW Simulators zu kalibrieren und dessen Realitätsbezug zu überprüfen.

Nach ein paar Minuten treffen Sie auf ein anderes Fahrzeug, das auf der rechten Spur fährt. Bitte folgen Sie diesem Auto, da es den richtigen Weg kennt. Fahren Sie so, dass keine anderen Fahrzeuge einscheren können!

Das Vorfahrende Fahrzeug wird mehrere unterschiedliche Bremsmanöver ausführen. Bitte reagieren Sie so, wie Sie im realen Verkehr reagieren würden aber denken Sie immer daran, nicht zu überholen.

Zu Beginn des Versuches bitte beschleunigen Sie auf Tempo 130km/h.

Die Fahrt dauert ca. 10 Minuten

Fahren mit dem Assistenzsysteme ACC (Active Cruise Control)

Das ACC (Adaptive Cruise Control) ist ein Assistenzsystem, das den Fahrer in der Fahrhandlung unterstützt, und zwar bei der Längsregelung. Das ACC-System erlaubt einem Fahrzeug, einem anderen Fahrzeug in einem gewünschten Abstand zu folgen. Der Fahrer hat somit die Tempomatfunktion, in der er sich eine gewünschte Reisegeschwindigkeit, sowie

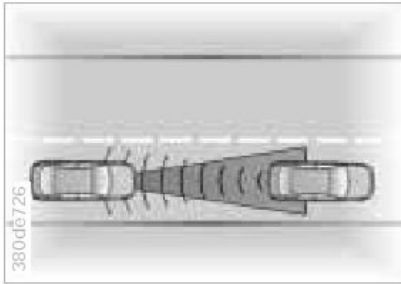

den Abstandsregler, in dem er einen gewünschten Abstand vom Vordermann einstellen kann. Wenn der Verkehrsfluß insgesamt langsamer als die eigene Geschwindigkeit verläuft, passt sich das Fahrzeug automatisch an die Geschwindigkeit an und folgt den anderen Fahrzeugen im eingestellten Abstand. Wenn die langsameren Fahrzeuge die Straße verlassen, beschleunigt das eigene System

automatisch auf die eingestellte Wunschgeschwindigkeit. Der Fahrer kann das System jederzeit durch Betätigung des Gaspedals übersteuern oder mit einem Bremsvorgang außer Kraft setzen.

Die Informationen über andere Verkehrsteilnehmer gewinnt das System über ein Radargerät, das seine Umgebung abtastet und auf alle vorausfahrenden Fahrzeuge mit einer Geschwindigkeit >20 km/h reagiert.

Hier liegen auch die **Grenzen des Systems**, die ein Fahrer für den sicheren Umgang kennen muss:

Stehende Hindernisse (z. B. parkende Fahrzeuge) werden vom System nicht erkannt: der Fahrer muss selbst eingreifen!

Fahrzeuge, die langsamer als 20 km/h fahren werden vom System nicht erkannt: der Fahrer muss selbst eingreifen!

Das System reagiert nicht auf Ampeln oder Fußgänger!: der Fahrer muss selbst eingreifen!

Das System hat nur eine **begrenzte Verzögerungskapazität**: Um ein komfortables Bremsen zu gewährleisten, das den Fahrer nicht verunsichert, ist beim ACC nur eine moderate Bremsverzögerung eingestellt. Die hat aber z. B. zur Folge, dass nicht auf alle Differenzgeschwindigkeiten zum Vordermann angemessen reagiert werden kann. Sehr starke Bremsvorgänge (weil z.B. ein Fahrzeug 50 km/h langsamer fährt als das eigene Fahrzeug) müssen vom Fahrer unter Umständen selbst übernommen werden.

Ein System kann immer fehlerbehaftet sein. D.h. möglicherweise ist die Sensorik ungenau und „übersieht“ vorausfahrende Fahrzeuge bzw. bremst, obwohl kein Fahrzeug zu sehen ist (falscher Alarm).

Insgesamt muss das ACC als Komfortsystem gelten. Es unterstützt den Fahrer, „erlöst“ ihn aber nicht von der Fahraufgabe. D.h. Der Fahrer muss jederzeit reagieren können, wenn ein System ausfällt, oder an seine Grenzen kommt. Er muss immer den Überblick über die Verkehrssituation und den Systemmodus behalten. UND: Im Falle eines Unfalls trägt er alleine die Verantwortung.

Bedienung des ACC-Systems

Die Bedienung des ACC erfolgt über die rechten, im Multifunktions-Lenkrad (MFL) angebrachten Tasten (Abbildung 1). Nach Betätigen der I/O-Taste rechts am Lenkrad ist das ACC bereit: erscheint eine grüne Leuchte in die Mitte des Tachometer.

Mit der Tempomat Taste (oder „Resume-Taste“ rechts oben am Lenkrad) wird auf Knopfdruck am Lenkrad eine Wunschgeschwindigkeit eingestellt. Mit diesem Befehl übernimmt das Fahrzeug die Temporegelung selbst, d.h. der Fahrer kann den Fuß vom Gaspedal nehmen. Bei einem Bremsvorgang schaltet sich das System automatisch ab, so dass der Fahrer jederzeit die Kontrolle über das Fahrzeug hat.



Abbildung 1: ACC-Bedienelemente im Multifunktions-Lenkrad (MFL)

Beim ACC erscheint im Tachometer ein ‚Dursichtige‘ Fahrzeug-Symbol wenn Sie sich im Tempomatmodus befinden (siehe Abbildung 2), und ein Schwarze Fahrzeug-Symbol wenn Sie sich im Folgemodus befinden.

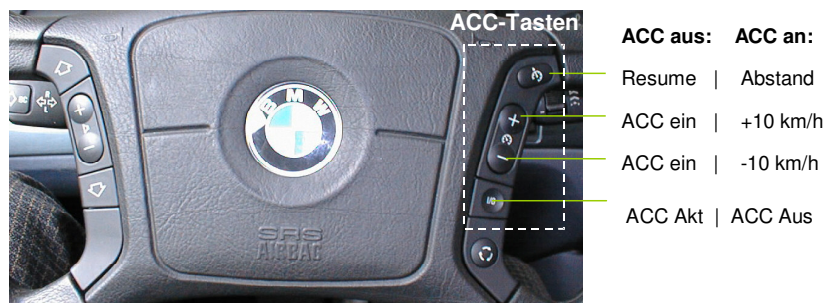

Abbildung 2. ACC befindet sich im Tempomatmodus.

Anweisung für Active Cruise Control (ACC) Einführung Fahrt

In diesem ‚Trainingsfahrt‘ werden Sie mit der Funktionsweise der Systeme vertraut gemacht.

Sie werden am Anfang vom Versuchsleiter aufgefordert, einige einfache ACC Manöver zu machen, damit Sie eine Einführung in das System und ein Gefühl für das System erhalten.

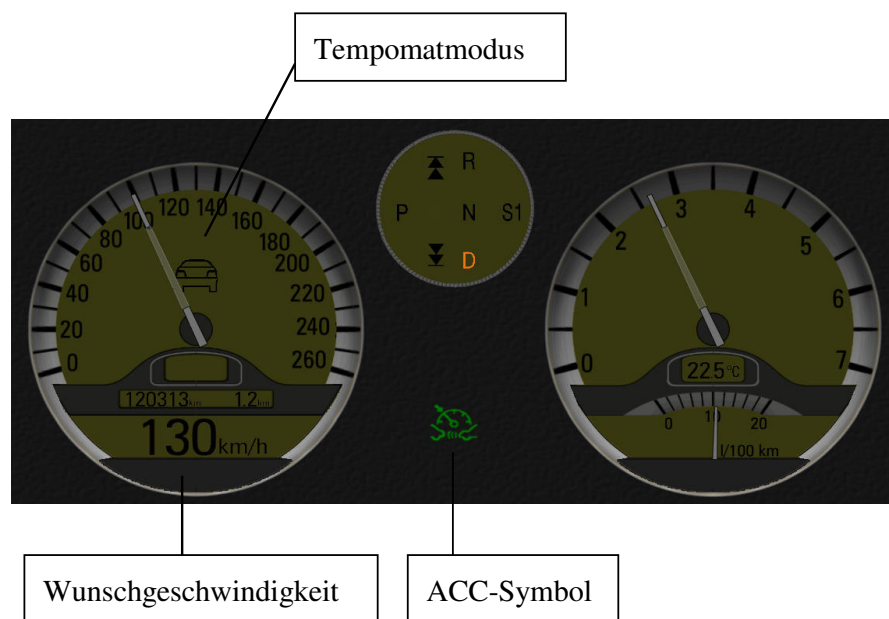
Nach ein paar Minuten treffen Sie auf ein anderes Fahrzeug. **Das ACC System wird automatisch den Abstand zum Vordermann halten** (bitte hier nicht bremsen – beobachten Sie nur was das ACC macht!)

Folgen Sie dann bitte diesem Fahrzeug (nicht überholen!).

Das vorausfahrenden Fahrzeug wird seine Geschwindigkeit in Intervallen im Bereich zwischen 80 und 150km/h verändern. Dazu sollten Sie unterschiedliche Systembremsstärken erfahren.

Die Fahrt dauert ca. 15 Minuten.

Anweisung zum Abstandswarnfunktion

Bei diesem Versuch geht es darum, dass Sie das Fahren mit dem Assistenzsystem „Active Cruise Control“ kennen lernen und eine Abstandswarnfunktion bewerten.

Bei einem erkannten Hindernis verzögert das ACC-System mit bis zu 2m/s^2 . Dies entspricht ca. 20% der maximal möglichen Verzögerung des Fahrzeugs.

Unfallgefahr!





Beim Erreichen der maximalen ACC-Verzögerung leuchtet die Abstandswarnleuchte im Geschwindigkeitsmesser auf und es ertönt ein Signalton.

Diese Information erfordert nicht unbedingt ein Eingreifen!

Der Signalton verstummt, wenn der Fahrer bremst oder der Soll-Abstand zum vorausfahrenden Fahrzeug wieder hergestellt ist. Dann erlischt auch die Abstandswarnleuchte.

Die Folgenden Tabelle fasst die ACC-abhängige Anzeigen und Ihre Bedeutungen zusammen:

		
ACC funktioniert in Tempomatmodus	ACC funktioniert in Folgemodus	Signalton: ACC auf max. Verzögerung Eingriff nicht unbedingt erforderlich

Anweisungen für Fahrt 1 und 2:

Jetzt werden Sie zweimal unter Nutzung des ACC-Systems einen Rundkurs von ca. 25km befahren. Während der Fahrt achten Sie bitte auf folgende Punkte:

Immer nach einem stehenden LKW die nächstmögliche Abfahrt benutzen.

Es soll möglichst immer mit ACC gefahren werden. Wird das ACC zum Beispiel durch eine Bremsung deaktiviert, soll es schnellstmöglich wieder aktiviert werden.

Auf der Autobahn, immer **130km/h** fahren und versuchen, diese Geschwindigkeit konstant zu halten. (Wunschgeschwindigkeit: 130km/h).

Sie dürfen **nicht** Überholen! Fährt vor Ihnen ein langsamere Fahrzeug, so sollte diesem hinterhergefahren werden (d.h. nicht überholen; nicht auf eine andere Spur fahren).

Ihre Aufgabe ist es, die Strecke ohne Fahrfehler zu bewältigen. Als Fahrfehler gelten (wie im realen Verkehr auch):

- Abkommen von der Fahrbahn
- Schlechte Spurhaltung oder Schleudern
- Kollisionen mit Fahrzeugen, Fußgängern oder Objekten

Bitte achten Sie darauf, dass das ACC-System technisch bedingte Grenzen hat und Sie die Verantwortung über das Fahrzeug tragen. Sie müssen somit jederzeit aufpassen und die Kontrolle über das Fahrzeug haben, auch wenn andere Verkehrsteilnehmer Fehler machen.

Zusätzliche Aufgabe

Wie bei der Einführungsfahrt, wird Ihre Reaktionszeit gemessen. Taucht der Reiz rechts auf, bestätigen Sie bitte den rechten Blinker. Für den linken Reiz benutzen Sie bitte den linken Blinker. Sie sollten so schnell wie möglich durch ein kurzes Antippen des Blinkers (Einrasten ist nicht erforderlich) bestätigen. Bitte bestätigen Sie den Blinker während des gesamten Versuchs nur für die Bestätigung des Reizes.

Zu Beginn der Fahrt beschleunigen Sie bitte zügig auf Tempo 130km/h und setzen dann den Tempomat.

Anweisungen für Test Fahrt:

Sie werden zunächst eine neue, ca. 20km lange Strecke befahren.

Während der Fahrt achten Sie bitte auf folgende Punkte:

Bei der erste Möglichkeit rechts abbiegen und dann bei der Ampel noch mal rechts abbiegen, dann immer geradeaus fahren.

Es soll möglichst immer mit ACC gefahren werden. Wird das ACC zum Beispiel durch eine Bremsung deaktiviert, soll es schnellstmöglich wieder aktiviert werden.

Auf der Autobahn, immer **130km/h** fahren und versuchen, diese Geschwindigkeit konstant zu halten. (Wunschgeschwindigkeit: 130km/h).

In der Stadt, auf der Mittlerering, bitte das ACC-Systems auf 60km/h setzen.

Sie dürfen **nicht** Überholen! Fährt vor Ihnen ein langsamere Fahrzeug, so sollte diesem hinterhergefahren werden (d.h. nicht auf eine andere Spur fahren).

Ihre Aufgabe ist es, die Strecke ohne Fahrfehler zu bewältigen. Als Fahrfehler gelten (wie im realen Verkehr auch):

- Abkommen von der Fahrbahn
- Schlechte Spurhaltung oder Schleudern
- Kollisionen mit Fahrzeugen, Fußgängern oder Objekten

Zusätzliche Aufgabe

Wie bei der letzte Fahrt, wird Ihre Reaktionszeit gemessen. Taucht der Reiz rechts auf, bestätigen Sie bitte den rechten Blinker. Für den linken Reiz benutzen Sie bitte den linken Blinker. Sie sollten so schnell wie möglich durch ein kurzes Antippen des Blinkers (Einrasten ist nicht erforderlich) bestätigen. **Bitte bestätigen Sie den Blinker während des gesamten Versuchs nur für die Bestätigung des Reizes.**

Die Fahrt dauert ca. 15 Minuten.

Zu Beginn der Fahrt beschleunigen Sie bitte zügig auf Tempo 90km/h und setzen dann den Tempomat.

Instructions for each drive in the enhanced group was the same. The only difference to the standard group in the administered instructions were regarding the ACC display. Information given to the enhanced group regarding the ACC display is presented here.

Fahren mit dem Assistenzsysteme ACC (Active Cruise Control)

Das ACC (Adaptive Cruise Control) ist ein Assistenzsystem, das den Fahrer in der Fahrhandlung unterstützt, und zwar bei der Längsregelung. Das ACC-System erlaubt einem Fahrzeug, einem anderen Fahrzeug in einem gewünschten Abstand zu folgen. Der Fahrer hat somit die Tempomatfunktion, in der er sich eine gewünschte Reisegeschwindigkeit, sowie

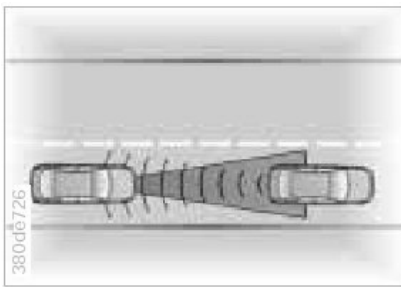

den Abstandsregler, in dem er einen gewünschten Abstand vom Vordermann einstellen kann. Wenn der Verkehrsfluß insgesamt langsamer als die eigene Geschwindigkeit verläuft, passt sich das Fahrzeug automatisch an die Geschwindigkeit an und folgt den anderen Fahrzeugen im eingestellten Abstand. Wenn die langsameren Fahrzeuge die Straße verlassen, beschleunigt das eigene System

automatisch auf die eingestellte Wunschgeschwindigkeit. Der Fahrer kann das System jederzeit durch Betätigung des Gaspedals übersteuern oder mit einem Bremsvorgang außer Kraft setzen.

Die Informationen über andere Verkehrsteilnehmer gewinnt das System über ein Radargerät, das seine Umgebung abtastet und auf alle vorausfahrenden Fahrzeuge mit einer Geschwindigkeit >20 km/h reagiert.

Hier liegen auch die **Grenzen des Systems**, die ein Fahrer für den sicheren Umgang kennen muss:

Stehende Hindernisse (z. B. parkende Fahrzeuge) werden vom System nicht erkannt: der Fahrer muss selbst eingreifen!

Fahrzeuge, die langsamer als 20 km/h fahren werden vom System nicht erkannt: der Fahrer muss selbst eingreifen!

Das System reagiert nicht auf Ampeln oder Fußgänger!: der Fahrer muss selbst eingreifen!

Das System hat nur eine **begrenzte Verzögerungskapazität**: Um ein komfortables Bremsen zu gewährleisten, das den Fahrer nicht verunsichert, ist beim ACC nur eine moderate Bremsverzögerung eingestellt. Die hat aber z. B. zur Folge, dass nicht auf alle Differenzgeschwindigkeiten zum Vordermann angemessen reagiert werden kann. Sehr starke Bremsvorgänge (weil z.B. ein Fahrzeug 50 km/h langsamer fährt als das eigene Fahrzeug) müssen vom Fahrer unter Umständen selbst übernommen werden.

Ein System kann immer fehlerbehaftet sein. D.h. möglicherweise ist die Sensorik ungenau und „übersieht“ vorausfahrende Fahrzeuge bzw. bremst, obwohl kein Fahrzeug zu sehen ist (falscher Alarm).

Insgesamt muss das ACC als Komfortsystem gelten. Es unterstützt den Fahrer, „erlöst“ ihn aber nicht von der Fahraufgabe. D.h. Der Fahrer muss jederzeit reagieren können, wenn ein System ausfällt, oder an seine Grenzen kommt. Er muss immer den Überblick über die Verkehrssituation und den Systemmodus behalten. UND: Im Falle eines Unfalls trägt er alleine die Verantwortung.

Bedienung des ACC-Systems

Die Bedienung des ACC erfolgt über die rechten, im Multifunktions-Lenkrad (MFL) angebrachten Tasten (siehe Abbildung 1). Nach Betätigen der I/O-Taste rechts am Lenkrad ist das ACC bereit: erscheint eine grüne Leuchte in die Mitte des Tachometer.

Mit der Tempomat Taste (oder „Resume-Taste“ rechts oben am Lenkrad) wird auf Knopfdruck am Lenkrad eine Wunschgeschwindigkeit eingestellt. Mit diesem Befehl übernimmt das Fahrzeug die Temporegelung selbst, d.h. der Fahrer kann den Fuß vom Gaspedal nehmen. Bei einem Bremsvorgang schaltet sich das System automatisch ab, so dass der Fahrer jederzeit die Kontrolle über das Fahrzeug hat.



Abbildung 1: ACC-Bedienelemente im Multifunktions-Lenkrad (MFL)

Beim ACC erscheint im Tachometer ein ‚Dursichtige‘ Fahrzeug-Symbol wenn Sie sich im Tempomatmodus befinden (siehe Abbildung 2), und ein Schwarze Fahrzeug-Symbol wenn Sie sich im Folgemodus befinden.

Abbildung 2. ACC befindet sich im Tempomatmodus.

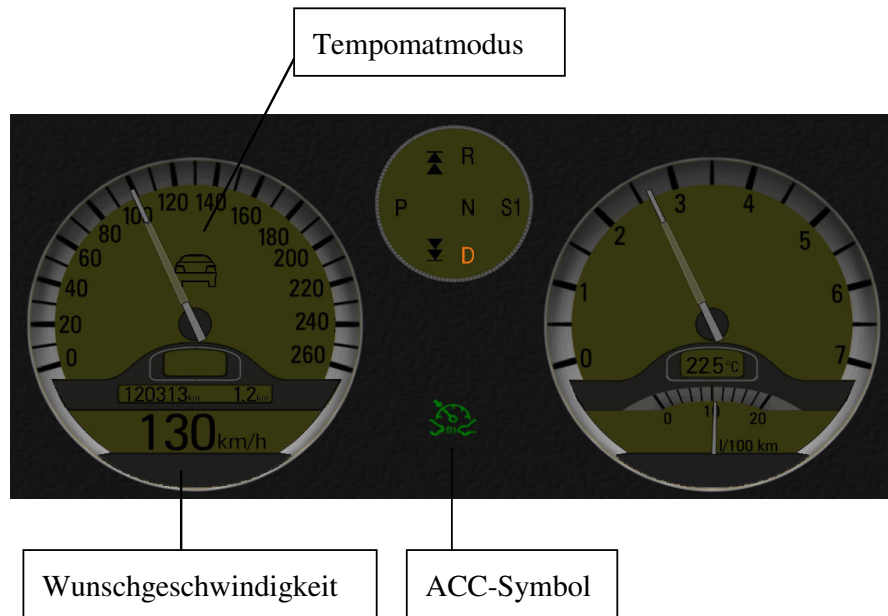

Anweisung zum Abstandswarnfunktion

Bei diesem Versuch geht es darum, dass Sie das Fahren mit dem Assistenzsystem „Active Cruise Control“ kennen lernen und eine Abstandswarnfunktion bewerten.

Bei einem erkannten Hindernis verzögert das ACC-System mit bis zu 2m/s^2 . Dies entspricht ca. 20% der maximal möglichen Verzögerung des Fahrzeugs.

Unfallgefahr!

Beim Erreichen der maximalen ACC-Verzögerung ertönt ein Intervall-Signalton. Diese Information erfordert nicht unbedingt ein Eingreifen!

Ohne Ihr Wissen haben wir während der Kalibrierungsfahrt Ihre persönliche Maximalverzögerung gemittelt und gespeichert. Das graphische Display des Warnsystems ist auf diesen Wert eingestellt. Somit ist die Anzeige für Sie personalisiert.

Ist eine größere Verzögerung erforderlich, unabhängig von der Funktion des ACC, leuchtet die Abstands-Warnleuchte im Geschwindigkeitsmesser auf. Dies erfolgt in folgenden Formen von Farb- und Größenänderungen:





Diese Änderungen werden unabhängig von der Funktion des ACC entsprechend der Gefährlichkeit der Situation ausgegeben.





Zusätzlich wird ein „**Kollisionsvermeidungs**“-**Alarmsignal** ausgegeben, das unabhängig von der Funktion des ACC ist. Dies erfordert eine **sofortige Bremsreaktion** mit Ihrer maximalen persönlichen Verzögerung!

Die Töne verstummen, wenn der Fahrer bremst oder der Soll-Abstand zum vorausfahrenden Fahrzeug wieder hergestellt ist. Dann erlischt die Warnleuchte oder springt in den vorhergehenden Zustand.

Die folgenden Tabelle fasst die *ACC-abhängige* Anzeigen und Ihre Bedeutungen zusammen:

		
ACC funktioniert in Tempomatmodus	ACC funktioniert in Folgemodus	Intervall-Signalton: ACC auf max. Verzögerung Eingriff nicht unbedingt erforderlich

Die Folgenden Tabelle fasst die personalisierte *ACC-unabhängige* Anzeigen und Ihre Bedeutungen zusammen:

			
Zeit bis zum notwendige Eingriff mit Ihrer max. persönlichen Verzögerung relativ groß	Zeit bis zum notwendige Eingriff mit Ihrer max. persönlichen Verzögerung geringer	Zeit bis zum notwendige Eingriff mit Ihrer max. persönlichen Verzögerung sehr gering	Kollisionsvermeidungs-Alarmsignal Sofortige Bremsreaktion mit Ihrer max. persönlichen Verzögerung!

Beispiel von „Gefährdung-Stufe 2“ am Tachometer:



The analysis of the questionnaire results for each group is presented here. The answers to questions 11-14 have been omitted in this section and can be found in section 5.3.3.

Q1. While using the ACC, I could always understand what was happening

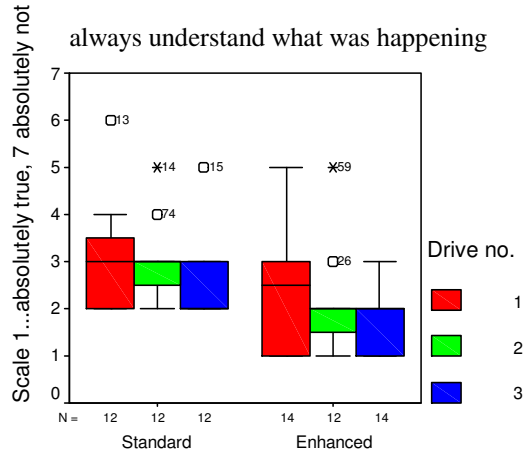

Condition

Q2. During the drive, I got a better understanding of when I needed to intervene

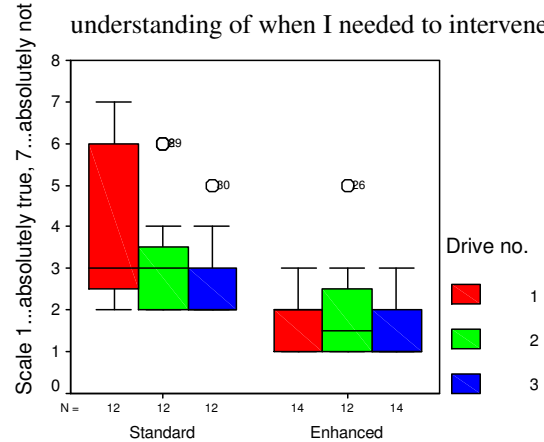

Condition

Q3. While driving with ACC, I found the distance to the lead vehicle safe

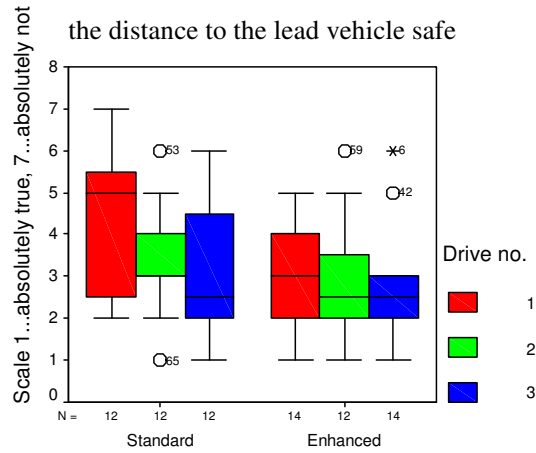

Condition

Q4. I felt safe in using the ACC

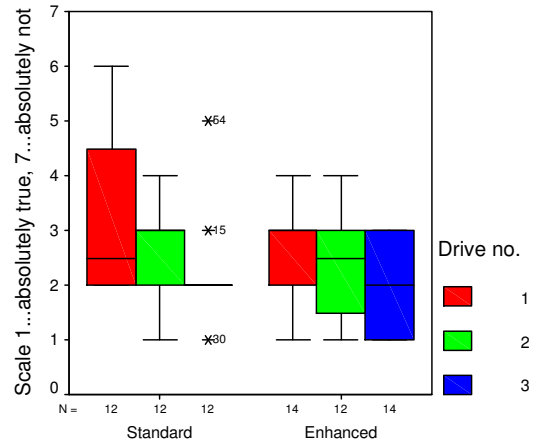

Condition

Q5. The ACC graphic display was helpful

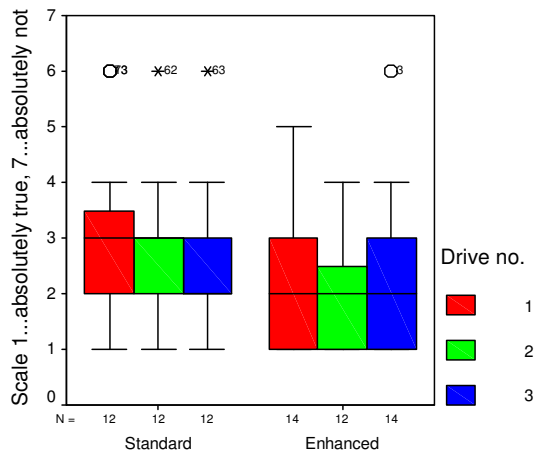

Condition

Q6. The ACC acoustic display was helpful

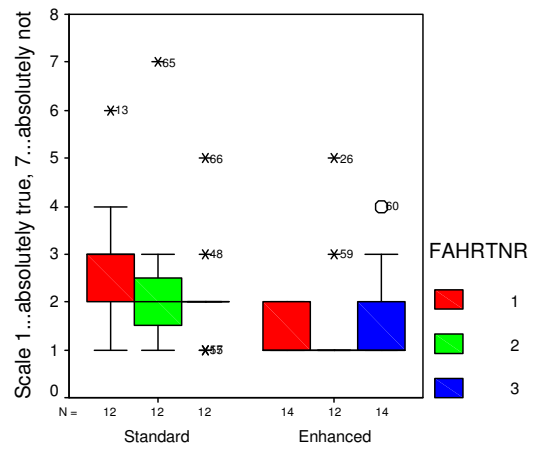

Condition

Q7. Whilst driving, the graphic display is a meaningful aid

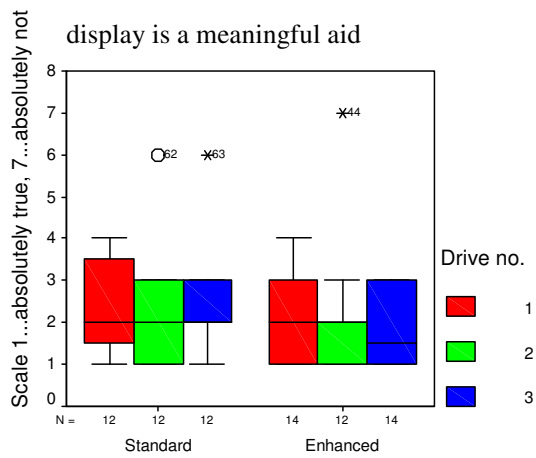

Condition

Q8. Whilst driving, the acoustic feedback is a meaningful aid

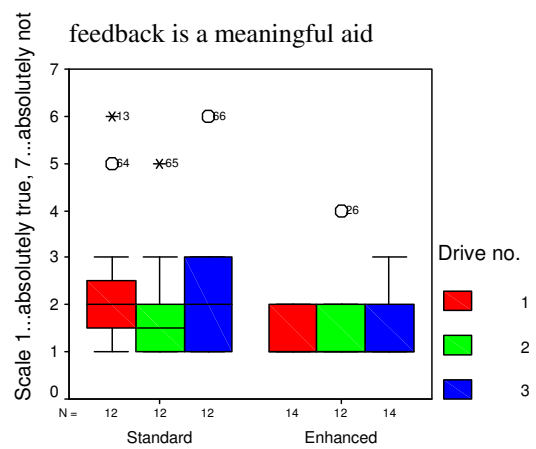

Condition

Q9. The ACC display is very important in the learning phase

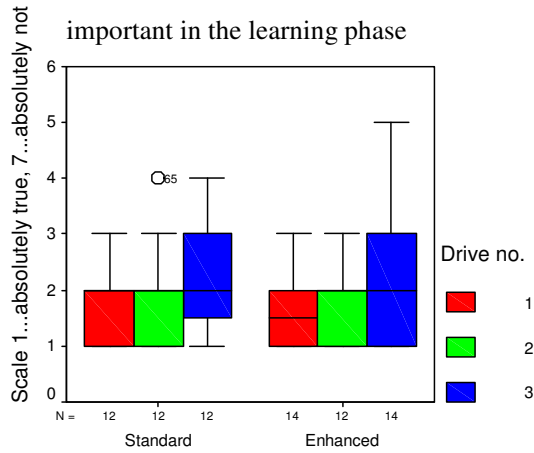

Condition

Q10. The deceleration limit of the ACC system was made clear by the display

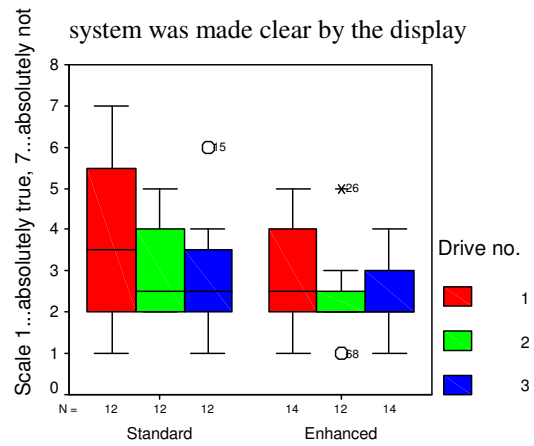

Condition

Q15. The ACC graphic display distracted me from driving

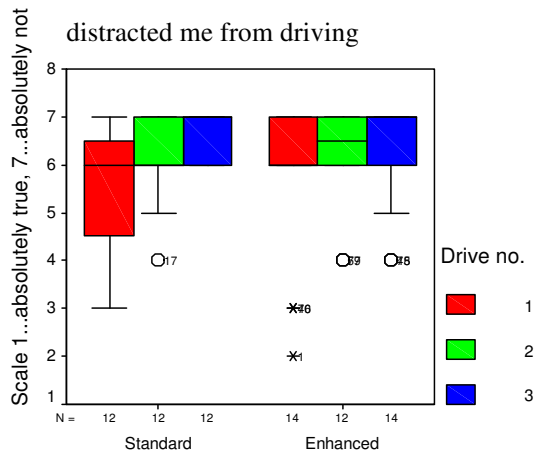

Condition

Q16. The ACC acoustic display distracted me from driving

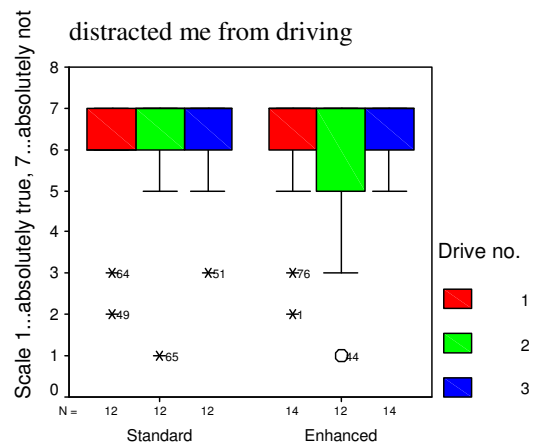

Condition

Q17. Changes in the display status were clearly identifiable

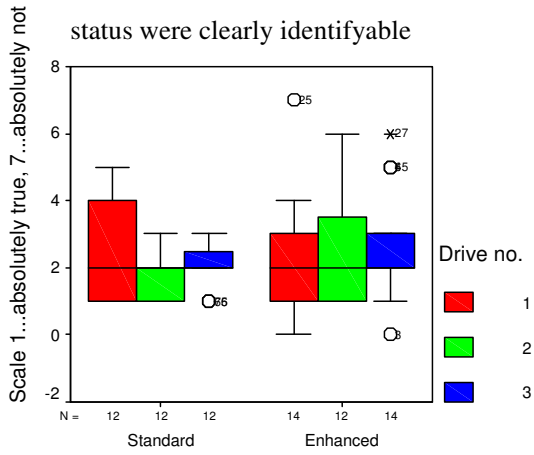

Condition

Q18. The graphic ACC display was irritating

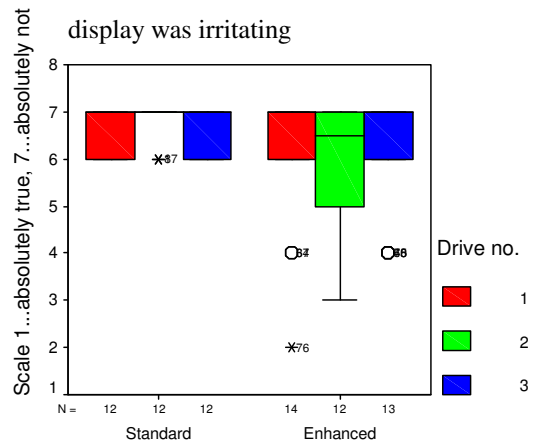

Condition

Q19. The acoustic feedback of the ACC display was irritating

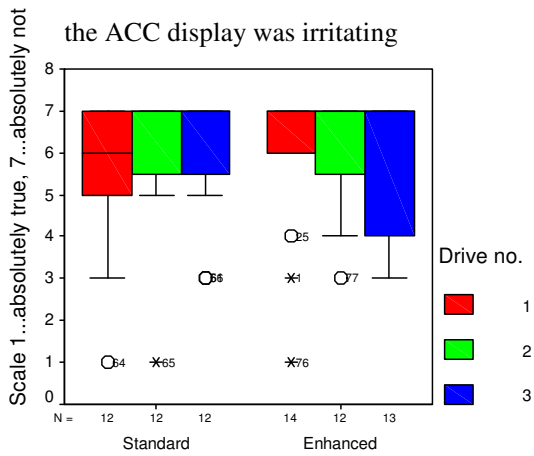

Condition

Q20. The timing of the acoustic feedback was:

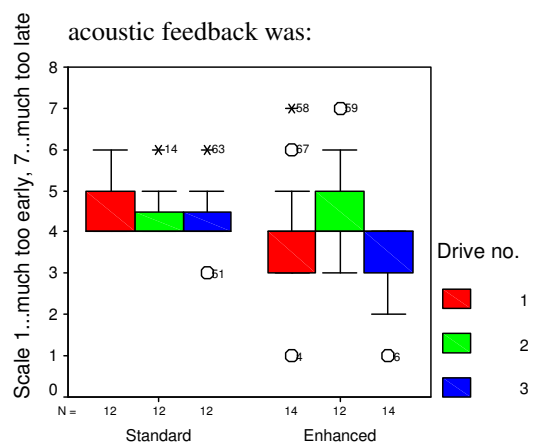

Condition