

James Madison University
JMU Scholarly Commons

Senior Honors Projects, 2010-current

Honors College

Spring 2014

Psychological effects of intensified cycle training and effectiveness testing of the mental/physical state and trait energy and fatigue scale

Jack Dyer Crouch III
James Madison University

Follow this and additional works at: <https://commons.lib.jmu.edu/honors201019>

Recommended Citation

Crouch, Jack Dyer III, "Psychological effects of intensified cycle training and effectiveness testing of the mental/physical state and trait energy and fatigue scale" (2014). *Senior Honors Projects, 2010-current*. 405.
<https://commons.lib.jmu.edu/honors201019/405>

This Thesis is brought to you for free and open access by the Honors College at JMU Scholarly Commons. It has been accepted for inclusion in Senior Honors Projects, 2010-current by an authorized administrator of JMU Scholarly Commons. For more information, please contact dc_admin@jmu.edu.

Psychological Effects of Intensified Cycle Training and Effectiveness Testing of the
Mental/Physical State and Trait Energy and Fatigue Scale

A Project Presented to
the Faculty of the Undergraduate
College of Health and Behavioral Studies
James Madison University

in Partial Fulfillment of the Requirements
for the Degree of Bachelor of Science

by Jack Dyer Crouch III

May, 2014

Accepted by the faculty of the Department of Kinesiology, James Madison University, in partial fulfillment of the requirements for the Degree of Bachelor of Science.

FACULTY COMMITTEE:

HONORS PROGRAM APPROVAL:

Project Advisor: Michael Saunders, Ph.D.,
Professor, Kinesiology

Barry Falk, Ph.D.,
Director, Honors Program

Reader: Christopher Womack, Ph.D.,
Professor, Kinesiology

Reader: Nicholas Luden, Ph.D.,
Assistant Professor, Kinesiology

Reader: Sarah Carson, Ph.D.,
Assistant Professor, Kinesiology

Table of Contents

List of Figures	3
Acknowledgements	4
Abstract	5
Introduction	7
Methods	13
Results	18
Discussion	25
Literature Cited	31

List of Figures

Figures

- 1 Experimental Design
- 2 Time Trial Performance

Tables

- 1 Cronbach's α Scores for POMS and MPSTEFs
- 2 Mental/Physical Energy and Fatigue Scores
- 3 "Worse than Normal" DALDA Scores
- 4 Total Mood Disturbance, Fatigue, and Vigor Scores
- 5 30-kilometer Time Trial Performance Correlations

Acknowledgements

There are many people I would like to thank that have helped me throughout the completion of my Honors Thesis while at JMU. I would like to thank the Honors Program here at JMU for the unique opportunity to complete an undergraduate research project. Next, I would like to thank my Honors Thesis Committee, Dr. Christopher Womack, Dr. Nicholas Luden, and Dr. Sarah Carson for their support and recommendations that aided me in completing this Honors Thesis. Next, I would like to thank my family and friends for their endless support of not only my Honors Thesis, but also my entire academic career here at JMU. Finally, I wish to thank my Honors Thesis Advisor, Dr. Michael Saunders, whose wisdom, guidance, and patience made this final project possible. I sincerely enjoyed my time working with you!

Abstract

Questionnaires such as the Profile of Mood States (POMS) and Daily Analysis of Life Demands for Athletes (DALDA) have been used to detect changes in mood and perceived feelings of fatigue/vigor in athletes. The present study tested the efficacy of a more recent questionnaire, Mental Physical State and Trait Energy and Fatigue Scales (MPSTEFS), to detect changes in perceived feelings of energy and fatigue during heavy exercise training. Sub-scales of the MPSTEFS include Physical Energy, Physical Fatigue, Mental Energy, and Mental Fatigue. POMS and DALDA questionnaire scores were used for comparison. Eight trained cyclists performed two exercise-training protocols. Each training protocol included three phases: Normal Training (NT), Intensified Cycle Training (ICT, 10 days with a 100% increase in training volume versus NT), and Reduced Volume Training (RVT, 10 days at 60% of NT training volumes). Following ICT, Physical Energy scores decreased significantly from NT while Physical and Mental Fatigue increased significantly from NT ($p < 0.05$). Mental Energy tended to decrease from NT, but the change was not statistically significant ($p = 0.078$). Following RVT, Physical Energy and Physical Fatigue significantly increased/decreased, respectively. Mental Energy and Fatigue tended to increased/decreased in a similar fashion, but these changes were not significant. Following RVT, Physical Energy and Fatigue significantly increased/decreased versus NT. Mental Energy and Fatigue followed similar patterns as their Physical counterparts, but these changes were not significant. Correlation analyses were performed between changes in cycling performance (30 km time trial) and changes in questionnaire scores across all time points. No significant correlations were observed, other than between changes in performance from ICT → RVT and changes in the Vigor/Activity subscale of the POMS questionnaire. Ultimately, the MPSTEFS tracked perceived feelings of energy and fatigue as well as the

established questionnaire, but should be investigated in future overreaching studies for verification.

Introduction

When applied to sport performance, the term “overreaching” is commonly used to describe a state in which athletes briefly increase training volumes and/or intensities to improve individual performance, and includes an exercise protocol during which athletes greatly increase training stresses for a predetermined period of time (5). While the increased training demands will initially result in decreased performance levels, overreaching can be used effectively to promote performance gains, when followed by appropriate periods of recovery (18). This form of overreaching is known as “functional overreaching”. For example, Coutts and associates (5) studied triathletes who were subjected to a 4-week intensified training period, followed immediately by a 2-week reduced training period. During the intensified-training and reduced-training periods, participants were required to run several 3-kilometer time trials. At the end of the intensified training period, running performance was reduced by 4% versus baseline levels. However, performance was then improved by 7% immediately following the reduced training phase, suggesting that the overall regimen was effective at promoting gains in performance. These findings have been corroborated by a number of other studies including Lamberts, et al. (15), Jeukendrup, et al. (13), and Halson, et al. (12).

To generate positive performance gains, it is crucial to balance the intensified workloads with adequate recovery times; otherwise, “non-functional overreaching” may occur. “Non-functional overreaching” is characterized by continued impairments in performance, which persist following the prescribed recovery period (10). If heavy training loads are maintained for an extended period of time, severe symptoms of poor performance and increased mental/physical fatigue can occur in athletes, with extended recovery time needed to restore performance. If adequate recovery is not provided, this condition can progress into “overtraining syndrome”

characterized by symptoms such as underperformance (3), chronic fatigue (3), increased susceptibility to infection (20), hormonal imbalances (17), changes in normal blood pressure, elevated basal metabolic rate, weight loss, excessive thirst, sleep disturbances, irritability, loss of self-confidence, and lack of appetite (15).

Questionnaires allow athletes to rate feelings of mental and physical capacity, as well as mood states, which are not always open for objective evaluation. Questionnaires are especially useful during periods of overreaching training, as the results of the questionnaires should be dichotomous in nature between the overreaching and recovery phase (9). As a result, this data may assist coaches in determining when recovery periods have been inadequate, allowing them to adjust training and/or recovery schedules to avoid overtraining. Several questionnaires such as the Profile of Mood States (POMS), and the Daily Analysis of Life Demands for Athletes (DALDA) have been used effectively to quantify psychological changes following intensified training and recovery (2,22). The POMS questionnaire includes 65 questions, with each question relating to a descriptive adjective of a personal mood. Responses are based on a psychometric 5-point Likert scale (0 = “no feelings” of the particular mood, and 4 = “extreme feelings” of the mood). The POMS questionnaire assesses the five negative mood states of Anger/Hostility, Confusion/Bewilderment, Depression/Dejection, Fatigue/Inertia, and Tension/Anxiety and the one positive mood state of Vigor/Activity. To generate the cumulative mood state score for “Total Mood Disturbance”, the positive Vigor/Activity subscale score is subtracted from the sum of the five negative mood state subscale scores. [i.e. $TMD = (AH+CB+DD+FI+TA)-VA$]. When examining psychological responses to exercise training, the Fatigue/Inertia, Vigor/Activity, and Total Mood Disturbance scores appear to be the most relevant categories. In a previous study, the POMS questionnaire was used to monitor training stresses after 5-weeks of intensified cycle

training, followed by a 1-week taper (13). Investigators reported that the Fatigue/Inertia and Vigor/Activity subscales were inversely related following the 5-weeks of intensified training (high Fatigue / low Vigor) and also following the 1-week taper (low Fatigue / high Vigor). Furthermore, a trend toward increased Total Mood Disturbance scores following the 5-weeks of intensified training was noted, but this change was not statistically significant (16). Other studies have reported similar outcomes with the POMS Scale including Dupuy, et al. (8) and Rietjens, et al. (21) providing some evidence for the efficacy of the POMS scale in assessing changes in energy/fatigue during and following overreaching protocols. Several studies have included internal consistency testing of the POMS questionnaire to ensure the reliability of the psychometric test. DiLorenzo et al. (7), distributed the POMS questionnaire to two sample groups to measure differences in mood states. They also included reliability testing of the 65-question POMS through Cronbach's α coefficients. In the first sample group, all subscales had a Cronbach's α coefficient of 0.80 or higher. The Cronbach's α coefficient for the Total Mood Disturbance Scale was 0.97, indicating higher levels of internal reliability within the POMS questionnaire. The internal consistency results from the second cohort looked relatively similar. All Cronbach's α coefficients (except the Confusion/Bewilderment subscale, $\alpha = 0.58$) were 0.84 or higher, and the Cronbach's α coefficient for the TMD scale was 0.94. Curran et al. (6), reported similar findings suggesting that the POMS questionnaire has high levels of internal reliability.

The DALDA scale has also been used to quantify exercise/training-related stresses. The scale is separated into two sections. Part A of the DALDA pertains to sources of stress: such as diet, home-life, work, friends, sport training, climate, sleep, recreation, and health, and Part B includes items related to mental and physical symptoms, like muscle pains, boredom, irritability,

general weakness, skin rashes, and congestion that may manifest as a result from the aforementioned causes of stress. Information is collected using a 3-point Likert-based scale, with three potential scoring options, “a” denotes “worse than normal”, “b” denotes “normal”, and “c” denotes “better than normal”. Coutts et al. utilized the DALDA to monitor triathletes who performed four weeks of intensified training, followed by a two week taper (4). The authors reported no significant differences in scores over time for Part A of the DALDA. However, the triathletes reported significantly more “worse than normal responses” following intensified training compared to baseline levels. Moreover, subjects reported fewer “worse than normal” scores following the two-week taper when compared to intensified training (4). Similar findings have been reported by other investigators including Halson, et al. (12) and Achten, et al. (1). Collectively, these studies suggest that the DALDA B subscale can be used to detect predictable changes in psychological stresses following overreaching protocols. During the generation of the DALDA scale, Dr. Brent Rushall (22) ensured the reliability of each measure through a simple experiment. Dr. Rushall implemented a controlled three-day period of training set by coaches for a group of 22 competitive swimmers. On day two of the training protocol the DALDA questionnaire was issued to measure sources and symptoms of stress. After the three-day training protocol, a two week break from the standardized training protocol was initiated. After two week break, subjects entered the exact same three-day training protocol and again, were administered the DALDA questionnaire on day two. This evaluation was performed a total of five times. After the experiment, Dr. Rushall removed any measures (source and symptom) that were not responded to in a similar manner on four of the five occasions.

The Mental and Physical State and Trait Energy and Fatigue Scales (MPSTEFs) is a more contemporary questionnaire used to assess subjects’ mental and physical facilities (9). For

each of the 12 survey items, participants rate the strength of their experience of a particular characteristic (e.g. vigor) by marking a hash along 100-millimeter visual scale with the two end points reading “I feel no vigor” to “Strongest feelings of vigor ever felt.” From the 12 ratings separate scores for physical energy, physical fatigue, mental energy, and mental fatigue are calculated. Unlike the POMS and the DALDA, the MPSTEFs questionnaire has not been used in published studies to quantify psychological changes in athletes during an overreaching protocol. Internal consistencies of the MPSTEFs scales were measured by Cronbach’s α coefficients. Prior to the final generation of the questionnaire, Dr. Patrick J. O’Connor determined reliability through a telephone survey of 202 adult residents of the United States. Cronbach’s α coefficients for each scale were greater than 0.82 indicating a high level of internal consistency (19). The potential benefit of offering the MPSTEFs as a replacement questionnaire for the POMS and DALDA lies in its ease of completion. Athletes and researchers alike would prefer a shorter, more efficient questionnaire, as it may prevent as long as the results provide similar information to previously validated methods. Thus, the main purpose of this study is to test the efficacy of the MPSTEFs to assess changes in perceived energy and fatigue following a functional overreaching protocol. Specifically, our study will address the objectives outlined below.

Objectives / Hypotheses

Objective 1: To determine if POMS, DALDA, and MPSTEFs scores are altered following a functional overreaching exercise protocol.

Hypothesis 1: POMS, DALDA, and MPSTEFs scores are all expected to be negatively impacted (meaning more negative mental/physical energy and mood states) following a 10-day period of intensified cycle training (ICT), and positively impacted following a subsequent 10-day period of reduced-volume training (RVT)

Objective 2: To determine if the changes in the questionnaires are related to changes in cycling performance.

Hypothesis 2: Changes in POMS, DALDA, and MPSTEFs are expected to correlate with changes in performance.

Objective 3: To determine if the MPSTEFs is as efficacious a predictor of performance changes as the POMS and DALDA.

Hypothesis 3: The MPSTEFs scores are expected to track changes in physical performance equally as well as the POMS and DALDA scales.

Methods

Ten endurance-trained cyclists were recruited for the study. All subjects had completed at least seven hours per week of cycle-based training for 2 months or more prior to the study. After being recruited Subjects also performed a graded exercise test to determine aerobic fitness levels ($\text{VO}_{2 \text{ max}}$), and maximum workload (W_{max}) at baseline. All subjects possessed a $\text{VO}_{2 \text{ max}} \geq 50$ mL*kg/min. Prior to the initiation of the study, all subjects signed an informed consent form and general health questionnaires were issued to assess individual health status. Individuals with preexisting injury, those taking medications to relieve soreness, or with milk allergies were excluded from the study. Mean subject age was 24 ± 7 years of age. Mean subject height was 174.4 ± 11.4 cm. Mean subject weight was 71.9 ± 11.6 kg. Mean subject preliminary $\text{VO}_{2 \text{ max}}$ was 63.2 ± 8.2 ml*kg/min. Mean subject power output was 318.8 ± 54.7 watts. Two subjects dropped from the study before completing the functional overreaching protocol (one due to time and commitment issues and the other due to non-compliance with dietary control procedures), and their data was not included in the results. Prior to the start of the study, the JMU Institutional Review Board approved all procedures.

Subjects participated in a functional overreaching protocol consisting of 14 days of normal training (NT) followed by 10 days of intensified cycle training (ICT), and ended with 10 days of reduced volume training (RVT). NT consisted of the subjects exercising at their typical average daily training volume and intensity. NT training volumes were standardized for each subject, using data from the first seven days of training (power output, heart rate, exercise duration and distance). These results were used to calculate average daily training volume and intensity for the subsequent training periods. After 14 days of NT, subjects completed ICT (consisting of 10 days of training with a 100% increase in average training volume versus NT).

Following ICT, subjects completed 10-days of RVT, in which training volume was reduced to 60% of average daily training volumes during NT.

Data for this study was obtained from a larger project examining nutritional supplementation during a functional overreaching protocol. (co-principle investigators: Dr. M. Saunders and Dr. N. Luden). All subjects received two different nutritional supplements over the course of two functional overreaching protocols. In one phase, carbohydrate supplementation (CHO) was provided during and following each exercise session during ICT and RVT. In the other phase, carbohydrate+protein (CHO+Pro) supplementation was provided during/following exercise (Figure 1) A crossover design was implemented so that each subject received both nutritional supplements during separate phases. Training protocols were kept constant across the two phases, and the order in which subjects received the treatments was randomized. A washout period of ≥ 14 days was provided between the two experimental periods. Furthermore, the subjects and investigators were blinded to the order of nutritional treatments until completion of the entire project.

Figure 1. Experimental Design

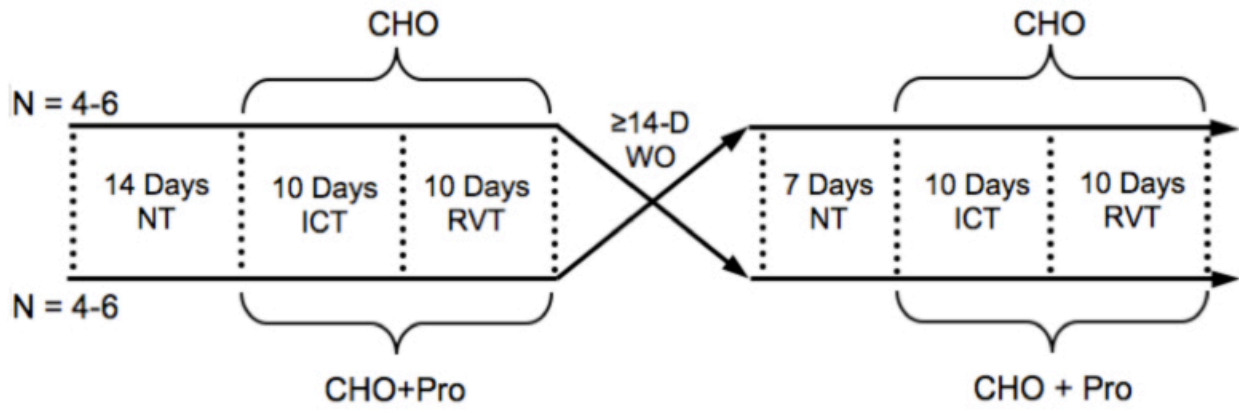

Figure 1 represents randomized double-blind crossover design utilized in the present study.

Obtained Measurements

Subjects reported to the laboratory following each training period (NT, ICT, and RVT) to complete a performance test. This performance test consisted of 2 hours of steady state cycling (at 50% of W_{\max} obtained during NT), immediately followed by a 30-kilometer time trial. Cycling performance was assessed via the time to complete the 30-km time trial.

Several psychological and physiological stress assessments were obtained during each phase of training. These questionnaires included the Daily Analysis of Life Demands for Athletes (DALDA), the 65-question version of the Profiles of Mood States (POMS), and the Mental/Physical State and Trait Energy and Fatigue Scales (MPSTEFS). The DALDA and MPSTEFS questionnaires were administered on three consecutive days at the end of each training phase. Due to the greater time commitment needed to complete the POMS scale, this assessment was administered on a single occasion at the completion of each training phase, which coincided with the final administration of the DALDA and MPSTEFS questionnaires. Subjects completed all questionnaires in the morning prior to training.

Statistical Analysis

A series of 3x2 (Time x Treatment) ANOVAs were employed to examine the effects of training and nutrition on the dependent measures (POMS score, DALDA score, Energy/Fatigue score, and performance). In addition, change scores between training phases (NT, ICT, RVT) were calculated for each dependent measure. Bivariate correlations were then calculated between changes in questionnaire scores and changes in performance during each of these time-points. Internal reliability tests were performed on both the POMS and MPSTEFS questionnaire to obtain a Cronbach's α score for each. Higher Cronbach's α scores indicate higher levels of

internal reliability within the questionnaire. These values were calculated from the data obtained from the two NT phases, as these scores were not directly influenced by treatment interventions or training protocols.

Results

No significant treatment-effects, or treatment x time interactions were observed for any of the dependent measures. Because no observable effects were detected between treatments (CHO and CHO+Pro), data were averaged across the two treatments to provide a single score for each dependent measure at each time point. All data presented in the results represent these averaged values.

Questionnaire Reliability

Table 1. Cronbach's α Scores for POMS and MPSTEFs

	Total Mood Disturbance	Fatigue/Inertia	Vigor/Activity	Physical Energy	Physical Fatigue	Mental Energy	Mental Fatigue
Cronbach's α	0.552	0.360	0.548	0.577	0.689	0.530	0.617

Table 1 illustrates the Cronbach α scores for the POMS questionnaire.

Table 1 illustrates the Cronbach's α scores for both the POMS questionnaire, and MPSTEFs questionnaire. All coefficients, except the Fatigue/Inertia subscale represent moderate levels of reliability within the MPSTEFs and POMS questionnaires, but no values were determined to be statistically significant.

Time Trial Performance

Average 30-kilometer time trial performances are shown in Figure 2. Mean values increased slightly from NT (56.0 ± 5.73) to ICT (56.54 ± 7.46) but this change was not statistically significant. However, a substantial outlier was identified, as one subject recorded a time during one NT trial that was about 13 minutes slower than their other trials. This score minimized the average decline in performance from NT to ICT. When this subject was removed from the analysis, the change in performance between NT – ICT increased to 1.44 minutes, but this difference was still not statistically significant ($p = 0.357$). Time trial performance following RVT (54.93 ± 6.20) was significantly faster than ICT ($p = 0.031$).

Figure 2. Time Trial Performance

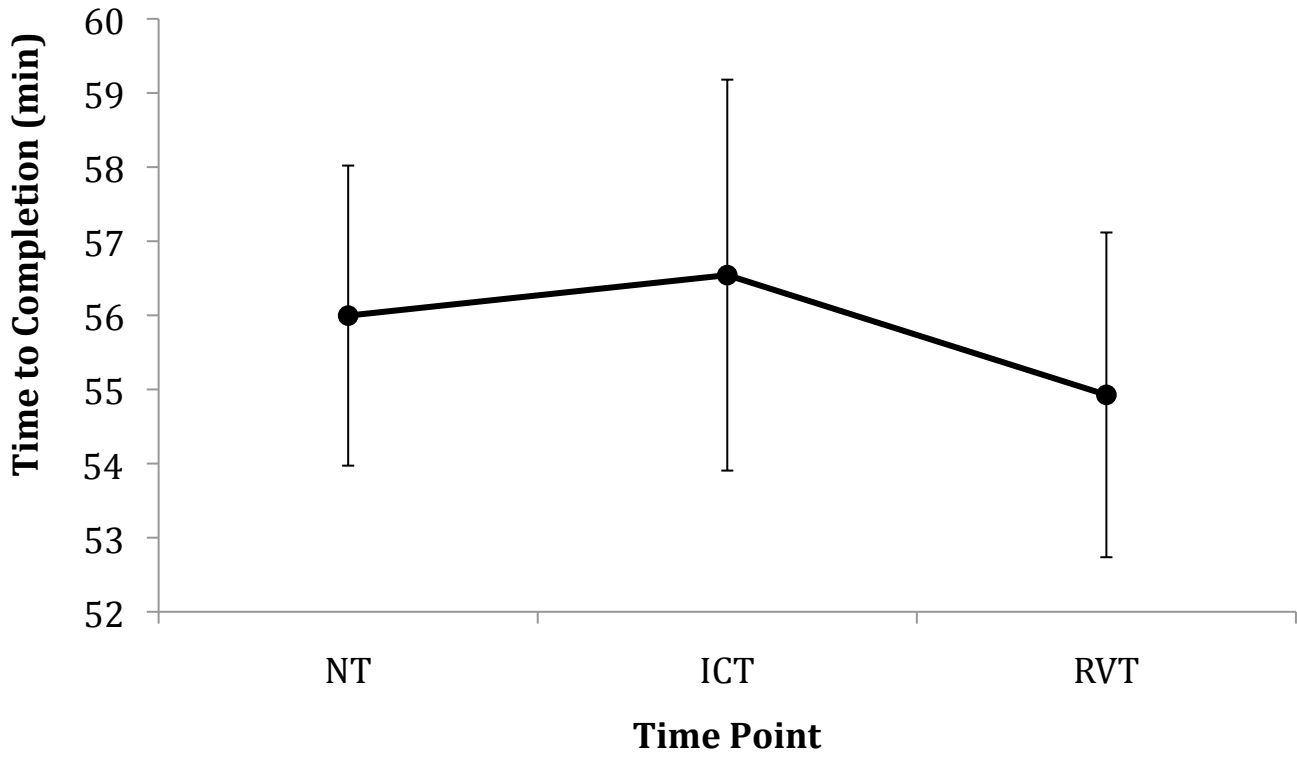

NT = Normal Training, ICT = Intensified Cycle Training (10 days with 100% increase in training volume versus NT), RVT = Reduced Volume Training (10 days with 60% decrease in training volume versus NT). Values are Mean \pm Standard Error of Mean

Table 2. Mental/physical energy and fatigue scores (mean \pm SD)

	NT	ICT	RVT	NT \rightarrow ICT	NT \rightarrow RVT	ICT \rightarrow RVT
Physical Energy	168 \pm 38	139 \pm 43*	192 \pm 43 ^{#&}	.018	.006	.003
Physical Fatigue	124 \pm 56	173 \pm 52*	191 \pm 51 ^{#&}	.011	.007	.000
Mental Energy	180 \pm 51	155 \pm 44	182 \pm 59	.078	.860	.196
Mental Fatigue	117 \pm 60	145 \pm 53*	108 \pm 64	.044	.387	.057

* = significant change between NT and ICT ($p < 0.05$). # = significant change between NT and RVT. & = significant change between ICT and RVT.

Table 2 illustrates changes in the dependent measures of the MPSTEPS questionnaire across the 3 times points as well as statistical significance between time points. Following ICT Physical Energy and Fatigue significantly decreased and increased from baseline, respectively. Meanwhile, Mental Energy and Fatigue decreased and increased from baseline, respectively, but the change in Mental Energy was not significant ($p = 0.078$). Following RVT, Physical Energy and Fatigue significantly increased and decreased, respectively. However, while Mental Energy and Fatigue increased and decreased relative to ICT, respectively, these changes were not statistically significant ($p = 0.196$, $p = 0.057$). Finally, following RVT, Physical Energy and Fatigue significantly increased and decreased beyond baseline levels. Mental Energy and Fatigue followed similar trends as Physical Energy and Fatigue, but these changes were found to be not statistically significant.

Table 3. “Worse than normal” DALDA scores (mean \pm SD).

	NT	ICT	RVT	NT \rightarrow ICT	NT \rightarrow RVT	ICT \rightarrow RVT
DALDA A	1.8 \pm 1.4	1.7 \pm 1.5	1.7 \pm 2.2	.600	.785	.956
DALDA B	3.0 \pm 2.2	5.2 \pm 4.2*	1.8 \pm 2.1 ^{&}	.045	.073	.008

* = significant change between NT and ICT ($p < 0.05$). [#] = significant change between NT and RVT. [&] = significant change between ICT and RVT.

Table 3 illustrates changes in the dependent measures of the DALDA questionnaire across the 3 time points as well as statistical significance between time points. DALDA A subscale scores did not significantly change across all time points. DALDA B subscale scores significantly increased following ICT ($p = 0.045$). DALDA B subscale scores then decreased significantly following RVT ($p = 0.008$). Following RVT, DALDA B subscale scores were lower than baseline, but this change was not statistically significant ($p = 0.073$).

Profile of Mood States

Table 4. Total Mood Disturbance, Fatigue, and Vigor scores (mean \pm SD).

	NT	ICT	RVT	NT \rightarrow ICT	NT \rightarrow RVT	ICT \rightarrow RVT
Total Mood Disturbance	7.9 \pm 19.2	10.1 \pm 18.9	6.8 \pm 17.4	.600	.725	.091
Fatigue / Inertia	6.7 \pm 4.3	8.9 \pm 4.5	5.1 \pm 3.6 ^{&}	.109	.225	.005
Vigor / Activity	19.0 \pm 6.1	16.8 \pm 6.7 [*]	15.6 \pm 7.5	.038	.109	.323

* = significant change between NT and ICT ($p < 0.05$). [#] = significant change between NT and RVT. [&] = significant change between ICT and RVT.

Table 4 illustrates changes in the dependent measures of the MPSTEFs questionnaire across the 3 time points as well as statistical significance between time points. No significant changes were detected across the time points for the Total Mood Disturbance scale. The Fatigue/Inertia subscale significantly decreased beyond baseline levels following RVT ($p = 0.005$). The Vigor/Activity subscale significantly decreased following ICT ($p = 0.038$).

Table 5. 30-kilometer Time Trial Performance Correlations (PE – MF refer to MPSTEFS questionnaire)

	PE	PF	ME	MF	DALDA B	POMS TMD	POMS F	POMS V
NT → ICT	-0.131	0.320	-0.555	0.477	0.423	-0.107	-0.472	0.51
ICT → RVT	0.88	-0.205	-0.271	0.230	0.445	0.186	0.307	0.796*
NT → RVT	0.405	0.369	0.496	-0.482	-0.076	-0.348	-0.719	-0.384

* =significant correlation ($p < 0.05$)

Table 5 illustrates correlations between the changes in dependent measures with change in 30-kilometer time trial performance. No changes in dependent measures strongly correlated with average changes time trial performance except for the POMS Vigor/Fatigue subscale following RVT relative to ICT.

Discussion

Several questionnaires have been utilized successfully in prior studies to rate feelings of exertion and mood during intensified training (1, 2, 5, 8, 12, 16, 21, 22). Monitoring perceived feelings of exertion and mood during intensified training may help coaches identify non-functional-overreaching in athletes, potentially allowing them to modify training protocols to promote adequate recovery. Evaluation tools that are short and easy to administer/evaluate are likely to be preferred by coaches and athletes for this purpose.

The present study evaluated the psychological effects (i.e. perceived feelings of vigor/fatigue) of intensified cycle training (ICT) followed by reduced volume training (RVT) in eight subjects as measured by three questionnaires. The POMS and DALDA questionnaires have been successfully utilized in previous studies to track these changes (1, 2, 5, 8, 12, 16, 21, 22), but the MPSTEFs questionnaire has never been examined in an overreaching protocol.

Scores on the DALDA B subscale were significantly affected by the overreaching protocol utilized in this study. Mean “worse than normal” scores significantly increased following ICT (relative to NT), and then significantly decreased following RVT. The reduction in “worse than normal scores” tended to be lower following RVT relative to NT, but this change was not statistically significant ($p = 0.073$). Prior investigators have reported similar changes in DALDA B scores in triathletes when exposed to an overreaching protocol (5). In addition, prior studies of trained cyclists/runners have also reported comparable changes in DALDA B scores following overreaching protocols (1, 12). Scores from the DALDA A subscale were not significantly affected by the overreaching protocol ($p = 0.935$). Similarly, prior studies have reported similar findings in which the DALDA A subscale did not significantly change throughout their respective overreaching protocols (5, 12).

Relevant measures of the POMS questionnaire (Total Mood Disturbance, Fatigue/Inertia, Vigor/Activity) tended to change in the expected directions following ICT. Vigor/Activity scores decreased significantly following ICT, while Fatigue/Inertia scores tended to increase, though not to a significant degree ($p = 0.109$). However, these alterations did not elevate Total Mood Disturbance scores to a significant extent ($p = 0.600$). Following RVT, Fatigue/Inertia scores were significantly lower than following ICT, and Total Mood Disturbance scores tended to be improved (though not to a significant extent; $p = 0.091$). Mean scores for Vigor/Activity decreased significantly following ICT ($p = 0.038$). Surprisingly, mean scores for Vigor/Activity decreased further following RVT, but this change was not statistically significant ($p = 0.323$). This result was not expected, as subjects were deliberately training at 60% of baseline, after having performed a grueling 10 days of a 100% increase from baseline. Furthermore, this result contradicts the expected inverse relationship between the Fatigue/Inertia and Vigor/Activity subscales reported by Martin et al. Martin and associates observed increased Fatigue/Inertia and decreased Vigor/Activity following the intensified training phase. Conversely, they observed decreased Fatigue/Inertia and increased Vigor/Activity following the reduced training volume phase (16). Furthermore, this anomaly also contradicts the Physical and Mental Energy scores on the MPSTEFs questionnaire. As previously stated, subjects reported increased feelings of Physical and Mental Energy following RVT in the MPSTEFs questionnaire, but the exact opposite in the POMS questionnaire. This anomaly cannot be directly explained, but could potentially be related to inattentiveness after multiple administrations of the relatively lengthy questionnaire. With the exception of this anomaly, the general directional trends observed in TMD and the Fatigue/Inertia and Vigor/Activity subscales tended to be similar to prior studies (8, 13, 21) and consistent with information provided by the DALDA scores.

Unlike the POMS and DALDA questionnaires, the MPSTEFS questionnaire has not been administered in previous studies investigating overreaching protocols. The four psychological subscales of the MPSTEFS questionnaire tracked well with the expected outcomes from the overreaching model, particularly the Physical Energy and Physical Fatigue measures. Mean Physical Energy scores significantly decreased from baseline following ICT ($p = 0.018$), and then significantly increased following RVT ($p = 0.003$). This increase in mean Physical Energy scores following RVT was significantly higher than NT ($p = 0.006$). Physical Fatigue tracked in the opposite direction (as expected), and changes between all time points were statistically significant. Average Mental Energy scores tended to move in a similar direction as the Physical Energy measure, but none of the changes between time points were statistically significant. Finally, mean Mental Fatigue scores significantly increased following ICT, and tended to decrease following RVT. However, changes between ICT and RVT ($p = 0.057$), and then NT and RVT ($p = 0.387$) were not statistically significant.

The MPSTEFS tracked well with the implemented overreaching protocol this study utilized. Expected trends of increased perceptions of fatigue following ICT, and recovery of energy following RVT were reflected by the data. The MPSTEFS appeared to track the expected changes similarly well in comparison to the DALDA. In addition, the MPSTEFS potentially detected changes with greater sensitivity than the POMS scale, based on the absence of statistically significant changes in numerous POMS scores, and the noted anomalies in Vigor/Activity scores following RVT. These findings generally support the use of the MPSTEFS to assess fatigue/energy in future overreaching studies. Furthermore, the MPSTEFS could be a useful device for coaches to identify potential markers of nonfunctional overreaching. Prolonged

scores of low Physical/Mental Energy, and high Physical/Mental fatigue could be indicative that an athlete requires additional recovery to avoid the overtraining syndrome.

The correlation analyses revealed no significant associations between changes in time trial performance and changes in psychological measures between time points with one exception. Changes in time trial performance between ICT and RVT was positively correlated ($p < 0.05$) with change in the Vigor/Activity. Interestingly, this correlation refers to the previously mentioned anomaly within the Vigor/Activity subscale. Due to the illogical possibility that decreases in perceptions of vigor are strongly correlated with improvements in Time Trial Performance, it is unlikely that this observation was truly sensitive to changes. As only one dependent measure was significantly correlated with time trial performance, the data suggests that these psychological measures are largely independent from changes in time trial performance. Performance can be affected by a substantial number of factors, not just relative feelings of fatigue and vigor, and changes in mood may only be a minor influence. In addition, the small sample size used in the study, and the homogeneous nature of the population sampled may have minimized the likelihood of detecting meaningful correlations between these variables.

The Cronbach's α scores between the POMS questionnaire and MPSTEFs questionnaire were relatively similar. The relatively low values for both questionnaires can possibly be explained, again, by a small, homogeneous sample size. In addition, the extended time-lapse between the two NT phases (> 1 month) also contributed to added variability between repeated administrations of the questionnaires. However, the similar values observed between the two scales indicate the MPSTEFs has similar consistency to the previously validated POMS scale, under these testing conditions.

As previously stated a limitation within this study was the small, homogeneous sample size. Furthermore, increasing the frequency of administration of the POMS questionnaire could have helped minimize the noted measurement error. Questionnaire reliability was based on two questionnaires that were completed roughly 40 days apart, potentially influencing questionnaire reliability. In order to minimize error, multiple questionnaires could be administered in the early phase of the study to generate more accurate reliability results.

In the future, more overreaching studies should include the MPSTEFs questionnaire to further validate its use in detecting nonfunctional overreaching and over training syndrome in athletes. Furthermore, the MPSTEFs should be utilized in studies that involve varying modes of exercise, not just cycling. (e.g. running, swimming, cross-country skiing). These studies could generate more reliable and accurate results by including a larger and more diverse sample size.

In summary, the POMS, DALDA, and MPSTEFs questionnaires all tracked relatively well with expected changes across the different phases of the overreaching protocol with very few exceptions. The MPSTEFs questionnaire was specifically tested in this overreaching protocol, and its success in detecting expected psychological changes indicates it can be utilized in future overreaching studies, and to detect nonfunctional overreaching in athletes. Additionally, the MPSTEFs questionnaire appeared to track psychological changes with greater sensitivity relative to the POMS questionnaire based on a greater proportion of significant outcomes across the protocol (i.e. lower p-values) and logical findings across all time points. This observation may suggest that the MPSTEFs questionnaire is more efficient in detecting nonfunctional overreaching in athletes, due to ease in completion and scoring relative to the POMS though further research is required to confirm this hypothesis. Analyses between changes in dependent measures of questionnaires and changes in time trial performance revealed no significant

correlations. Finally, reliability analyses reported relatively low consistency between repeated measurements of the POMS and MPSTEFS questionnaires. While neither questionnaire was deemed highly reliable by this study, the POMS and MPSTEFS questionnaires shared similar levels of consistency, under these specific testing conditions, and variability may have been related to the sample size and/or a long time period between measurements.

Literature Cited

1. Achten, J., Halson, S. L., Moseley, L., Rayson, M. P., Casey, A., & Jeukendrup, A. E. (2004). Higher dietary carbohydrate content during intensified running training results in better maintenance of performance and mood state. *Journal of Applied Physiology*, 96(4), 1331-1340.
2. Berger Bonnie G. & Motl, Robert W. Exercise and mood: A selective review and synthesis of research employing the profile of mood states, *Journal of Applied Sport Psychology*, 12:1, 69-92, 2000
3. Budgett, R. (1998). Fatigue and underperformance in athletes: the overtraining syndrome. *British journal of sports medicine*, 32(2), 107-110.
4. Coutts AJ, Wallace LK, and Slattery KM. Monitoring changes in performance, physiology, biochemistry, and psychology during overreaching and recovery in triathletes. *Int J Sports Med* 28: 125-134, 2007.
5. Coutts, Aaron J., Katie M. Slattery, and Lee K. Wallace. "Practical tests for monitoring performance, fatigue and recovery in triathletes." *Journal of Science and Medicine in Sport* 10.6 (2007): 372-381.
6. Curran, S. L., Andrykowski, M. A., & Studts, J. L. (1995). Short Form of the Profile of Mood States (POMS-SF): Psychometric information. *Psychological Assessment*, 7(1), 80.
7. DiLorenzo, T. A., Bovbjerg, D. H., Montgomery, G. H., Valdimarsdottir, H., & Jacobsen, P. B. (1999). The application of a shortened version of the profile of mood states in a sample of breast cancer chemotherapy patients. *British Journal of Health Psychology*, 4(4), 315-325.)
8. Dupuy, O., Renaud, M., Bherer, L., & Bosquet, L. (2010). Effect of functional overreaching on executive functions. *International journal of sports medicine*, 31(9), 617.
9. Gilson SF, Saunders MJ, Moran CW, Moore RW, Womack CJ, and Todd MK. Effects of chocolate milk consumption on markers of muscle recovery following soccer training: a randomized crossover study. *J Int Soc Sports Nutr*: 19, 201.
10. Halson SL, and Jeukendrup AE. Does overtraining exist? An analysis of overreaching and overtraining research. *Sports Med* 34:967-981, 2004.
9. (11) Halson, S. L., Lancaster, G. I., Jeukendrup, A. E., & Gleeson, Michael. Immunological responses to overreaching in cyclists. *Medicine and Science in Sports and Exercise*, 35(5), 854-861, 2003.
10. (12) Halson, S. L., Bridge, M. W., Meeusen, R., Busschaert, B., Gleeson, M., Jones, D. A., & Jeukendrup, A. E. (2002). Time course of performance changes and fatigue markers during intensified training in trained cyclists. *Journal of applied physiology*, 93(3), 947-956.

11. (13) Jeukendrup, A. E., Hesselink, M. K. C., Snyder, A. C., Kuipers, H., & Keizer, H. A. (1992). Physiological changes in male competitive cyclists after two weeks of intensified training. *International journal of sports medicine*, 13(07), 534-541.
14. Johnson, M. B., & Thiese, S. M. (1992). A Review of Overtraining Syndrome—Recognizing the Signs and Symptoms. *Journal of athletic training*, 27(4), 352.
- 12 (15). Lamberts, R. P., Swart, J., Noakes, T. D., & Lambert, M. I. (2009). Changes in heart rate recovery after high-intensity training in well-trained cyclists. *European journal of applied physiology*, 105(5), 705-713.
- 13 (16). Martin, David T., M. B. Andersen, and W. Gates. "Using Profile of Mood States (POMS) to monitor high-intensity training in cyclists: group versus case studies." *Sport Psychologist* 14.2 (2000): 138-156.
- 14 (17). Meeusen, R., Duclos, M., Foster, C., Fry, A., Gleeson, M., Nieman, D., & Urhausen, A. (2013). Prevention, diagnosis, and treatment of the overtraining syndrome: joint consensus statement of the European College of Sport Science and the American College of Sports Medicine. *Medicine and science in sports and exercise*, 45(1), 186-205.
- 15 (18). Nederhof E, Lemmink KA, Visscher C, Meeusen R, and Mulder T. Psychomotor speed: possibly a new marker for overtraining syndrome. *Sports Med* 36: 817-828, 2006.
19. O'Connor, P. Mental and Physical State and Trait Energy and Fatigue Scales: Preliminary Manual. April 2004.
- 16 (20). Parry-Billings, Mark., Budgett, Richard, Koutedakis, Yiannis, Blomstrand, E., Brooks, Steven, Williams, Clyde, & Newsholme, E. A. (1992). Plasma amino acid concentrations in the overtraining syndrome: possible effects on the immune system. *Medicine and science in sports and exercise*, 24(12), 1353-1358.
- 17 (21). Rietjens, G. J. W. M., Kuipers, H., Adam, J. J., Saris, W. H. M., Van Breda, E., Van Hamont, D. A., & Keizer, H. A. (2005). Physiological, biochemical and psychological markers of strenuous training-induced fatigue. *International journal of sports medicine*, 26(1), 16-26.
- 18 (22). Rushall Brent S. A tool for measuring stress tolerance in elite athletes, *Journal of Applied Sport Psychology*, 2:1, 51-66, 1990.