

SÜREKLİ YÜK AKIŞINDA STATİK GERİLİM KARARLILIĞINA STATCOM VE SSSC'NİN ETKİSİNİN İNCELENMESİ

Kenan DÖŞOĞLU *, Ali ÖZTÜRK, Bilal SARAÇOĞLU

Özet

Bu çalışmada türkiyedeki 22 baralı bir güç sisteminde statik gerilim kararlılığı FACTS cihazlarından STATCOM ve SSSC ile incelenmiştir. Farklı yük baralarına STATCOM'un bağlanması ve farklı iletim hatlarına SSSC'nin bağlanması ile güç sisteminin gerilim ve maksimum yüklenme parametreleri arasındaki ilişki belirlenmiştir. Bu benzetim çalışması Güç Sistemleri Araç Kutusu Analizi (PSAT) ile incelenmiştir. Bazı yük baralarındaki statik gerilim kararlılığı sonuçları şekiller ve tablo halinde sunulmuştur. Sürekli güç akışının yapıldığı bu sistemde STATCOM ve SSSC'nin kullanılması ile yük baralarında statik gerilim kararlılığının iyileştirildiği bulunmuştur.

Anahtar Kelime: STATCOM, SSSC, Gerilim Kararlılığı, Sürekli Yük Akışı

INVESTIGATION OF THE EFFECTS OF STATCOM AND SSSC STATIC VOLTAGE STABILITY CONTINUATION POWER FLOW OPERATION

Abstract

In this study, static voltage stability of Turkey 22 bus power system was been examined by using STATCOM and SSSC that known as FACTS devices. According to STATCOM and SSSC connected to different load busses and different transmission lines, the relationship of power system between voltage and maximum load parameters was determined. Voltage stability results of some load busses are presented in figures and tables. At this system that was made continuous power flow, through use of STATCOM and SSSC healing to voltage stability of load busses was revealed.

Keyword: STATCOM, SSSC, Voltage Stability, Continuous Power Flow

1.Introduction

Increase or decrease of power system load values, leads to voltage and reactive power changes of load bus, tap changer changes, output power changes of generator and changes electric power flow from the transmission line. These changes in the system voltage stability problems are uncovered. In system, very quickly control mechanisms are needed to eliminate voltage instability situations. So Flexible AC Transmission System Devices (FACTS) that has great power semiconductors are used [1]. FACTS devices are classified as Static Synchronous Compensators (STATCOM), Static VAR Compensators (SVC), Static Synchronous Series Compensators (SSSC), Thyristor Controlled Series Compensators (TCSC) and the Unified

* Düzce Üniversitesi, Teknik Eğitim Fakültesi, Elektrik Eğitimi Böl. Düzce.
E-posta: kenandosoglu@duzce.edu.tr

Power Flow Controllers (UPFC) In this study, STATCOM and SSSC used, this devices known as FACTS devices. FACTS devices in power systems are widely used in different areas. During transient stability studies, in the 39 bus power systems that has 10 generator, STATCOM and SSSC were used for broken out of the system oscillations [2,3]. Infinite bus system various load conditions, active-reactive power, current, voltage, capacitor voltage, total harmonic distortion in the distribution line reactance and phase angle changes were observed with STATCOM and SSSC[4]. By using STATCOM and SSSC, during the transient stability, frequency control was provided [5]. In the 30 and 300 bus systems of IEEE, the power flow analysis has been done with STATCOM connected to different load bus[6]. Depending on the different constant control models, small signal and transient stability analysis were examined with SSSC [7]. SVC and TCSC that known FACTS devices, small-signal and transient stability studies were used [8-9]. Load bus active power-voltage curves were examined at the SVC and TCSC load flow analysis. In terms of static voltage stability, SVC and TCSC were used in IEEE different bus systems [10-11]. In this study, systems according to STATCOM and SSSC to be added different load bus, the relationship between the maximum load parameters and voltage examined in the Turkey 22 bus power systems.

2. Static Synchronous Compensator (STATCOM)

STATCOM is the reactive power compensation where the reactive power and voltage magnitude of the system can be adjusted such as shown in Fig. 1.

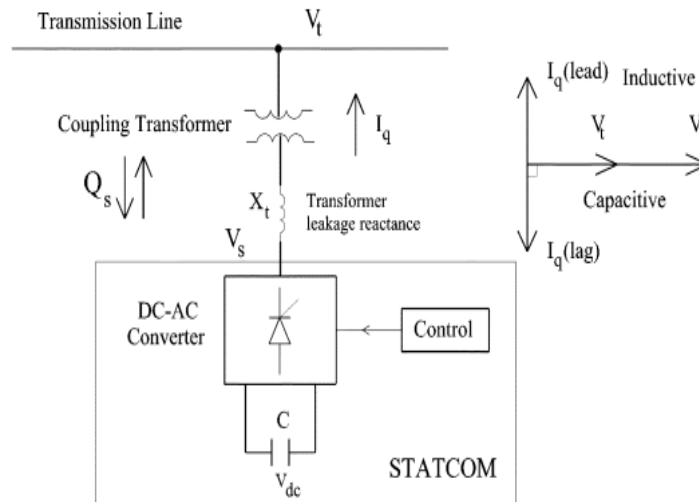

Fig. 1. STATCOM circuit models

It consists of three shunt (coupling) transformer, voltage source converter (VSC), and capacitor. It consists of three shunt (coupling) transformer, voltage source converter (VSC), and capacitor. The reactive power is distributed in the power system by the converter control. The STATCOM active P and reactive power Q are shown equal (1) and (2).

$$P = \frac{V_s V_i}{X_s} \sin \delta \quad (1)$$

$$Q = \frac{V_s^2}{X_s} - \frac{V_s V_i}{X_s} \cos \delta \quad (2)$$

where, X_s coupling transformer equivalent reactance, V_i converter output voltage, V_s AC system voltage, δ phase angle. The STATCOM is a combination of a voltage sourced converter and an inductive reactance and shunt connected to power system. The convert supplies leading current to the AC system if the converter output voltage is made to lead the corresponding AC system voltage. Then it supplies reactive power to the AC system by capacitive operation. Conversely, the converter absorbs lagging current from the AC system; if the converter output voltage is made to lag the AC system voltage then it absorbs reactive power to the AC system by inductive operation. If the output voltage is equal to the AC system voltage, the reactive power exchanges [12]. The controller model of STATCOM is shown in Fig. 2.

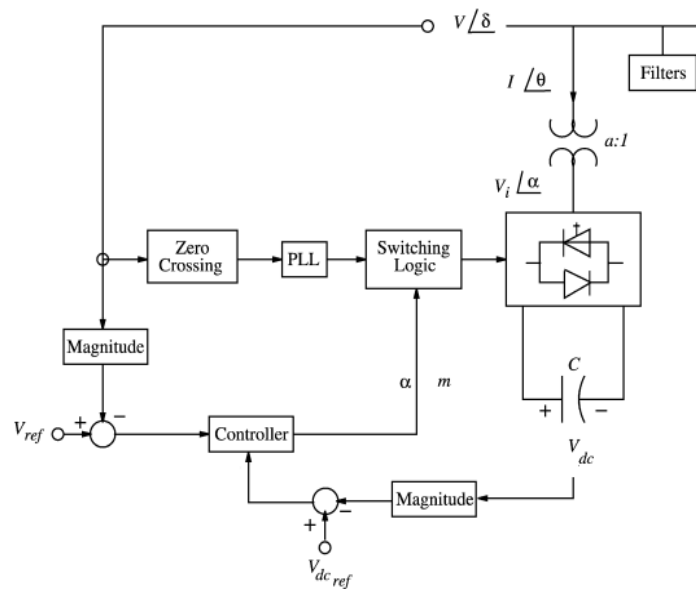

Fig..2 Control model STATCOM

Measured voltage, STATCOM capacitor voltage and reference voltage enters the controller unit. Zero crossing and phase-locked loop set to trigger the semiconductor of converter so phase- phase angle and modulation index coefficients are determined [13].

3. Static Synchronous Series Compensator (SSSC)

SSSC are connected with transmission lines as series. SSSC, the line current can be controlled directly. SSSC has been shown in Fig. 3.

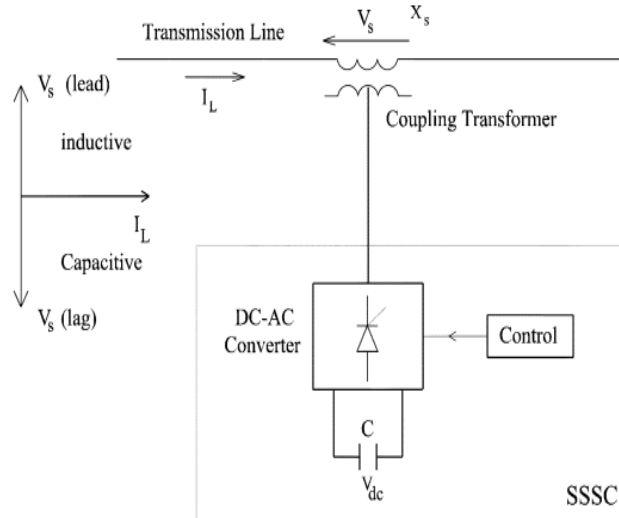

Fig..3 SSSC circuit modeling

Static Synchronous Series Compensators (SSSC) has occurred voltage source inverters, DC capacitor, the control unit and the coupling transformer. The real and reactive power (P and Q) flow at the receiving-end voltage source are given by the expressions,

$$P = \frac{V_s V_r}{X_L} \sin(\delta_s - \delta_r) \quad (3)$$

$$Q = \frac{V_s V_r}{X_L} (1 - \cos(\delta_s - \delta_r)) \quad (4)$$

where V_s and V_r are the magnitude and δ_s and δ_r are the phase angles of the voltage V_s and V_r , respectively. For simplicity, the voltage magnitude are choose such that $V_s = V_r = V$ and the difference between the phase angle is $\delta = \delta_s - \delta_r$ [14]. The main function of the SSSC as a series compensator is the control of transmission line power flow. This can be accomplished by either direct control of the line current power or alternatively by indirect control of either compensating series impedance, or injected series compensating voltage [15]. The controller models of SSSC are shown in Fig. 4.

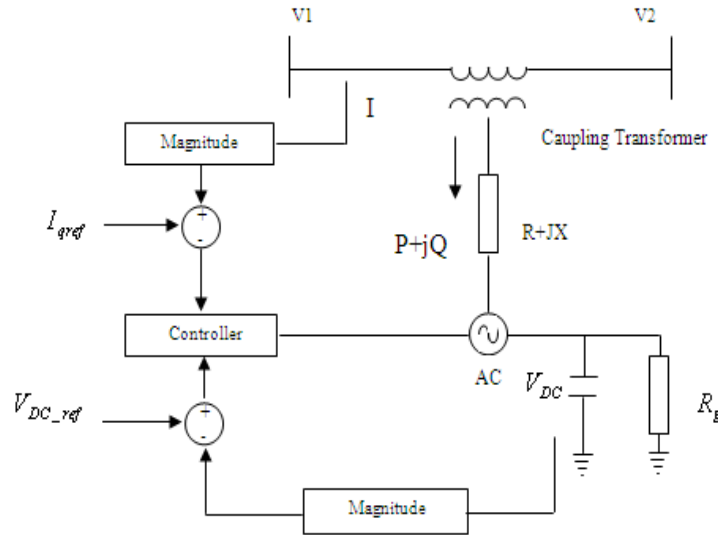

Fig.4. Control model SSSC

Measured current and voltage values are compared with reference values of current and capacitor and enters controller unit. Controller unit is tailored to system to the desired operating conditions.

4. Static Voltage Stability

Static voltage stability is mainly associated with reactive power imbalance. Reactive power support that the bus receives from the system can limit loadability of that bus and hence the entire system. If the reactive power support reaches the limit, usually maximum limit, the system will approach the maximum loading point or voltage collapse point due to high real and reactive power losses [16]. In static voltage stability, slowly developing changes in the power system occur that eventually lead to a shortage of reactive power and declining voltage. This phenomenon can be seen from the plot of the voltage at receiving end versus the power transferred. As the power transfer increases, the voltage at the receiving end decreases. The maximum load that can be increased prior to the point at which the system reactive power is depleted is called static voltage stability margin or loading margin (LM) of the system. Standard voltage-maximum loading parameter ($V - \lambda$) buses with P and Q thermal limit. Active and reactive load power defined as,

$$P_L = P_{LO}(1 + \lambda) \quad (5)$$

$$Q_L = Q_{LO}(1 + \lambda) \quad (6)$$

where, P_{LO} and Q_{LO} represent the initial active and reactive loads at bus and constants P_L and Q_L respectively represent the active and reactive load increase direction of bus, λ system maximum loading parameter. Introducing FACTS devices at the appropriate location, where the reactive power support needed the most, is an effective way to increase voltage stability margin. It can be also viewed as a way to reduce reactive power losses, as the power flow is changed to less congested lines [17].

5. Defining of Problem

There are one slack bus, six generator bus and 15 load bus in the Turkey 22 bus power systems [18]. System model was shown figure 5.

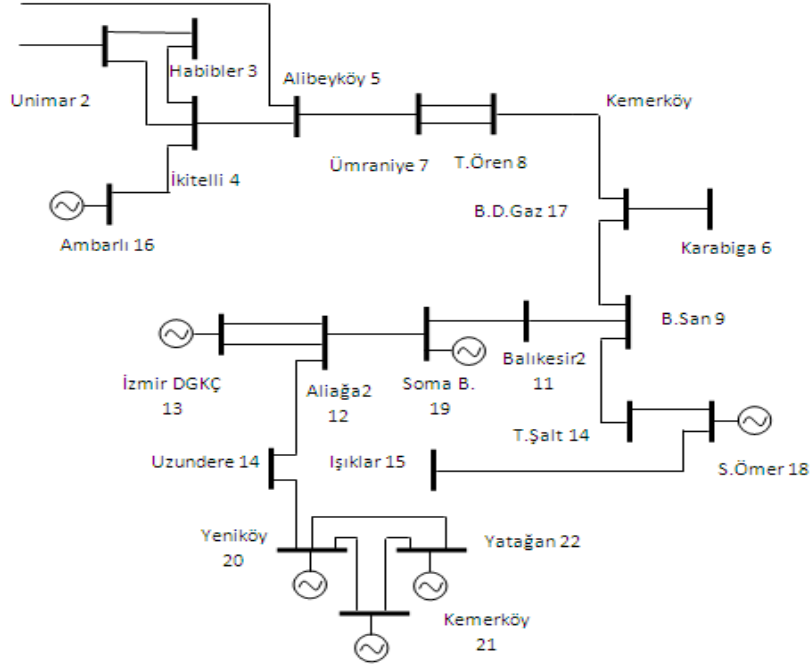

Fig. 5. 22 buses power system models

Static voltage stability of this system was investigated with 100 MVar STATCOM and SSSC. In this study, maximum load parameter values investigated at operating conditions of SSSC and STATCOM. While STATCOM connected load bus number 14, SSSC connected transmission lines between and 6-17 numbered bus. Power flow analysis of system has been examined by has been PSAT program [19]. Initially depending on FACTS devices, the rates of increase of load bus values were observed. During the study with continuous load flow, STATCOM, and SSSC the relationship between maximum loading parameter and voltage were shown in figures. The results were also presented in tables.

6. Solution of Problem

The simulation work in this system as a priority, irrespective of FACTS devices continuous load flow analysis was carried out. As a result of continuous load flow analysis, maximum load of the system parameter values were found to be 6.0941. In a later stage continuously load flow analysis was carried out depending on connected to STATCOM to bus number 14. In the analysis results with STATCOM, maximum load parameter value was 6.3623. Obtained results of the some load bus between the maximum loading parameter and voltage ($V - \lambda$), were shown in figure 6, 7, 8, 9.

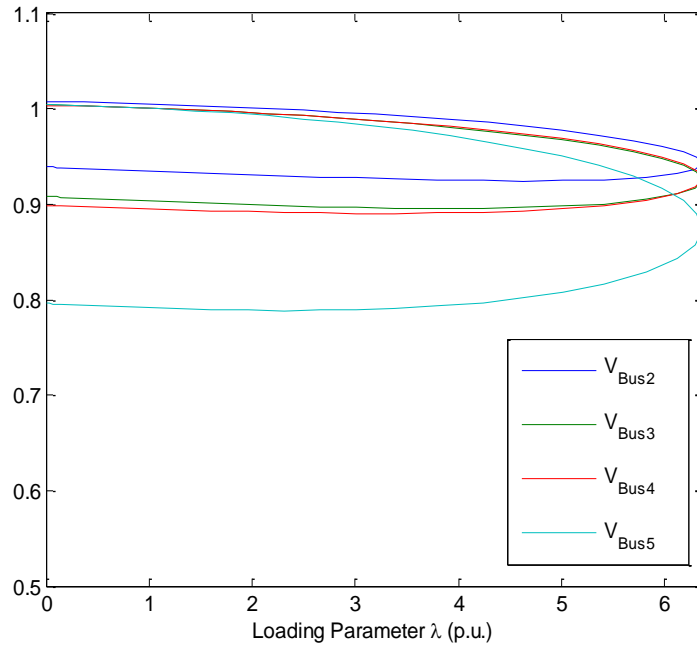

Fig. 6. ($V - \lambda$) Curve obtained bus 2,3,4,5 with connected STATCOM of load bus number 14

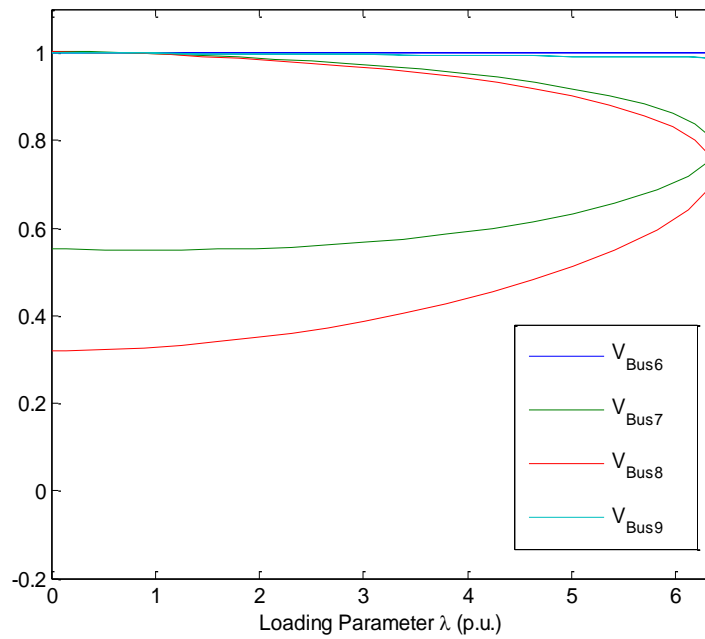

Fig. 7 ($V - \lambda$) Curve obtained bus 6,7,8,9 with connected STATCOM of load bus number 14

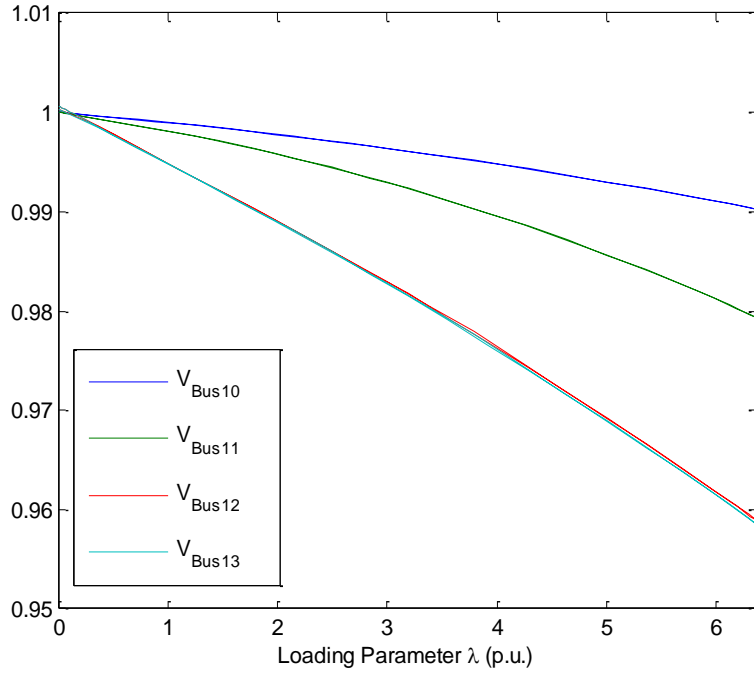

Fig. 8 ($V - \lambda$) Curve obtained bus 10, 11,12,13 with connected STATCOM of load bus 14

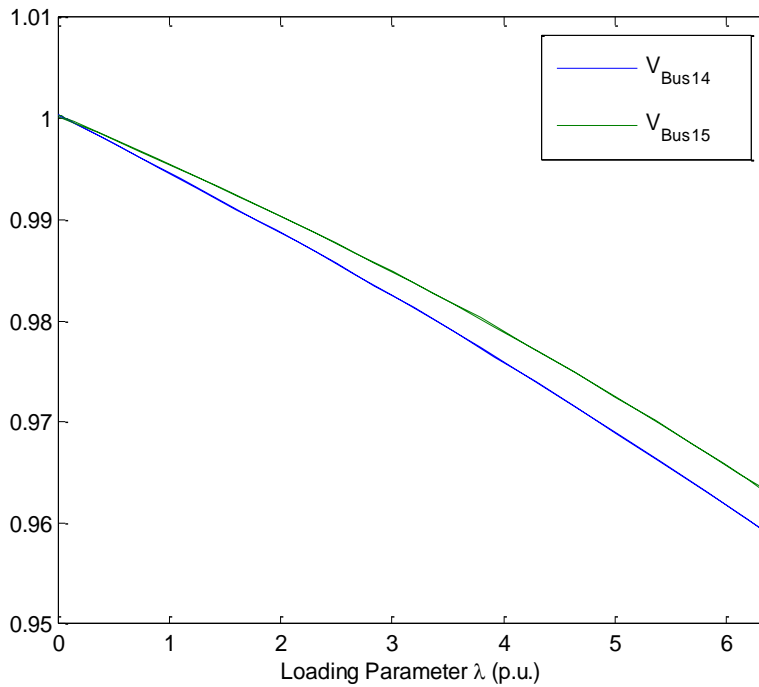

Fig. 9 ($V - \lambda$) Curve obtained bus 14, 15 with connected STATCOM of load bus 14

SSSC was connected to series with the transmission line that connected between bus number 6 and bus number 17. In this case continuous load flow analysis was conducted. Parameters of the system maximum load were found to be 6.3533 at the SSSC compensation twenty-five per

cent in value. Obtained results of the some load bus between the maximum loading parameter and voltage ($V - \lambda$), were shown in figure 10, 11, 12, 13.

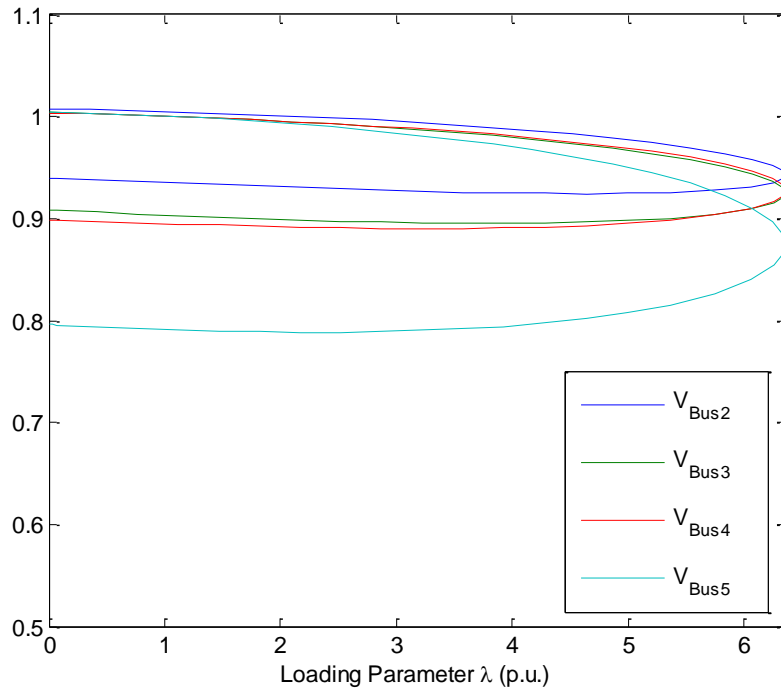

Fig. 10 ($V - \lambda$) Curve obtained bus 2,3,4,5 with connected STATCOM of between buses 6 and 17

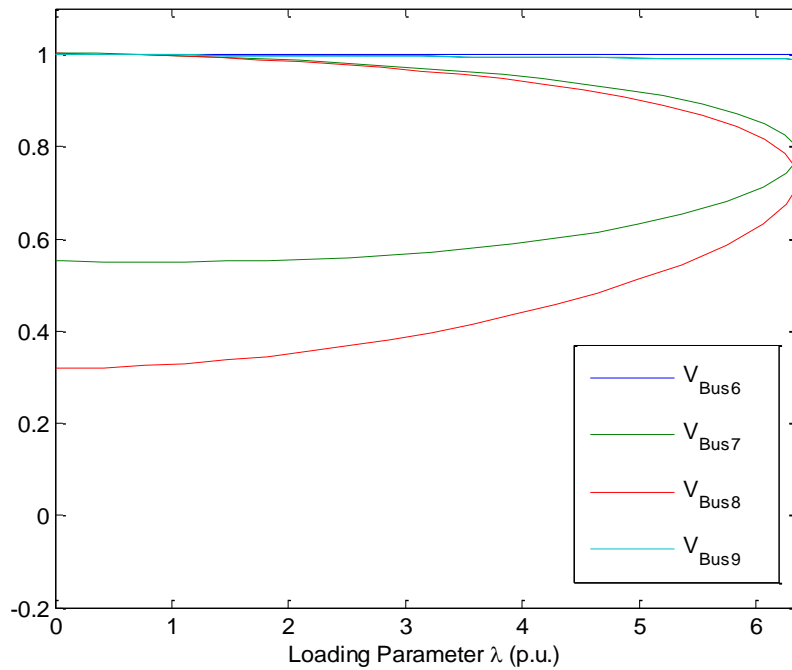

Fig. 11 ($V - \lambda$) Curve obtained bus 6,7,8,9 with connected STATCOM of between buses 6 and 17

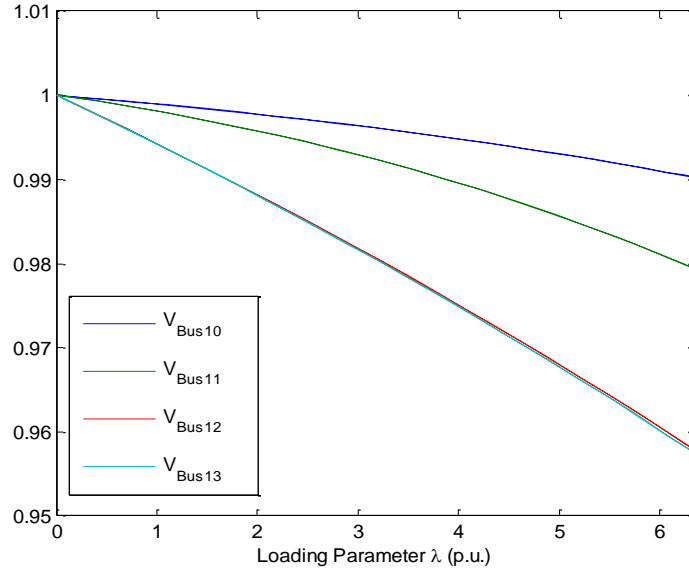

Fig. 12 ($V - \lambda$) Curve obtained bus 10,11,12,13 with connected STATCOM of between buses 6 and 17

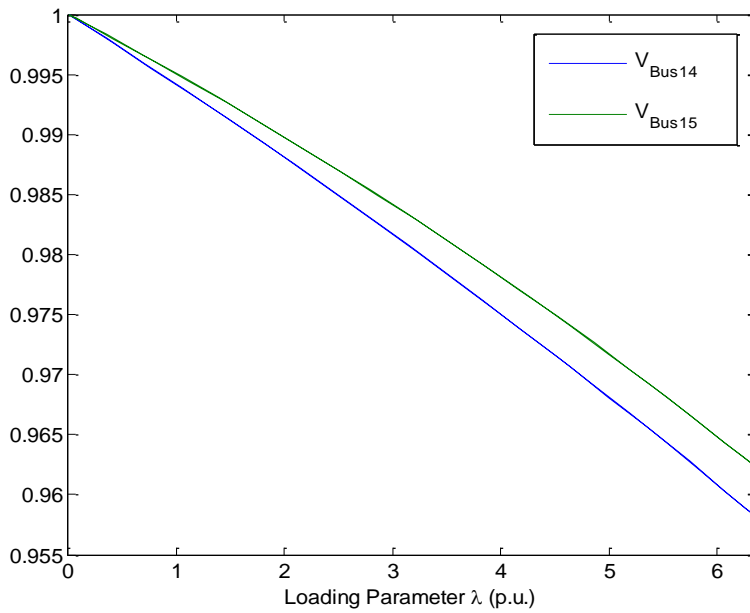

Fig. 12 ($V - \lambda$) Curve obtained bus 14,15 with connected STATCOM of between buses 6 and 17

Maximum loading parameter results obtained through STATCOM, SSSC and base case are shown on table 1 and table 2.

Table 1. Results of base case, STATCOM and SSSC maximum loading parameter

-	with base case	with STATCOM	with SSSC

λ_{\max} (p.u)	6.0741	6.3623(with connecting 14 bus)	6.3533(with connecting among 6-17 bus)
------------------------	--------	--------------------------------	--

Table 2. Ratio reactance with connecting 6-17 buses of SSSC maximum loading parameter

λ_{\max}	Reactance compensation of line connecting buses 6-17
6.3533	%25
6.3562	%50
6.3591	%75
3.3620	%100

8. Result

In this simulation study, static voltage stability of Turkey 22 bus power systems were investigated by using STATCOM and SSSC that known as FACTS device. Thanks to FACTS device, according to normal operating conditions relationship between the load parameter and voltage were found to be enlarged from continuous load flow analysis. In this study was found that in case of STATCOM connected to load bus as parallel obtained greater load capacity than connected to transmission line of SSSC as series. With the increase in the percentage of SSSC reactance, the maximum load parameters were found to increase. As a result can said to growth system operation range from and increase values voltage and maximum loading parameter with STATCOM and SSSC on voltage stability studies.

9. References

- 1) Modi P.K., Singh S.P., Sharma J.D., "Voltage stability evaluation of power system with FACTS application using fuzzy neural network", *Engineering Application of Artificial Intelligence*, 20: 481-491 (2007).
- 2) Haque M.H., "Damping improvement by FACTS devices: A comparison between STATCOM and SSSC", *Electric Power System Research*, 76: 865-872 (2006).
- 3) Du W., Chen Z., Wang H.F., Dunn R., Zhong S., "Capability of STATCOM and SSSC damping control to improve power system oscillation stability part-1 theoretical analysis", *42nd International Universities Power Engineering Conference*, 1-3: 657-662 (2007).
- 4) El-Moursi M.S., Sharaf A.M., "Novel reactive power controllers for the STATCOM and SSSC", *Electric Power System Research*, 76: 228-241 (2006).
- 5) Molina M.G., Mercado P.E., "Comparative evaluation of performance of a STATCOM and SSSC both integrated with SMES for controlling the power system frequency", *IEEE/PES Transmission and Distribution Conference and Exposition*, 535-541 (2004).

- 6) Zhang Y., Zhang Y., Wu B., Zhou J., “Power injection model of STATCOM with control and operating limit for power flow and voltage stability analysis”, *Electric Power System Research*, 76: 1003-1010 (2006).
- 7) Castro M.S., Ayres H.M., da Costa V.F., da Silva L.C.P., “Impacts of the SSSC control models on small-signal and transient stability of a power system”, *Electric Power System Research*, 77: 1-9 (2007).
- 8) Gu W., Milano F., Jiang P., Tang G., “Hopf bifurcations induced by SVC controllers: A didactic example”, *Electric Power System Research*, 77: 234-240 (2007).
- 9) Kazemi A., Badrzadeh B., “Modeling and simulation of SVC and TCSC to study their limits on maximum loadability point”, *Electric Power System Research*, 26: 381-388 (2004).
- 10) Talebi N., Ehsan M., Bathaee S.M.T., “Effect of SVC and TCSC Control Strategies on Static Voltage Collapse Phenomena”, *Southeast Conference*, Mar. 2004, pp.161–168.
- 11) Moghavvemi, M., Faruque, M.O., “Effect of FACTS Devices on Static Voltage Stability”, *TENCON2000*, Sept. 2000, pp.357-362.
- 12) Lin W., Lu K., Huang C., Ou T., Li Y., “Optimal location and capacity of STATCOM for voltage stability enhancement using ACO plus GA”, *IEEE/ASME International Conference on Advanced Intelligence Mechatronics*, 1915-1920 (2009).
- 13) Norouzi A.H., Sharaf A.M., “Two control schemes to enhance the dynamic performance of the STATCOM and SSSC”, *IEEE Transaction on Power Delivery*, 20 (1): 435-442, (2005).
- 14) Sen K.K., “SSSC- Static synchronous series compensator: theory, modeling and application”, *IEEE Transaction on Power Delivery*, 13 (1): 241-246, (1998).
- 15) Moursi M., Sharaf A.M., Arroudi K., “Optimal control schemes for SSSC dynamic series compensation”, *Electric Power System Research*, 78: 646-656 (2008).
- 16) Sode-Yome A., Mithulananthan N., Lee K.Y., “A maximum loading margin method for static voltage stability in power systems”, *IEEE Transaction on Power Systems*, 21: 799-808, (2006).
- 17) Sode-Yome A., Mithulananthan N., Lee K.Y., “A comprehensive comparison of FACTS devices for enhancing static voltage stability”, *IEEE Power Engineering Society General Meeting*, 1-8 (2007).
- 18) Başaran Ü., “Various Power Flow and Economic Dispatch Analysis on 380 Kv Interconnected Power System in Turkey”, *Master of Science Thesis*, Anadolu University, Natural Science Institute, Eskişehir, 77-79 (2004).
- 19) Milano F., “Power System Analysis Toolbox (PSAT)”, Version 1.3.4., *Software and Documentation* (2005).