

The use of simple models in the teaching of the essentials of masonry arch behaviour

Santiago Huerta

Traditional masonry is today an unusual material, it is alien to us at the beginning to the 21st. century. The usual assumptions for structural materials: homogeneity, isotropy, elastic constants (Young's modulus, Poisson's coefficient), etc., do not apply or are irrelevant in respect to masonry.

Most important, though masonry presents a good strength in compression, is very weak to tension; its behaviour is 'unilateral'. This fact has paramount importance in masonry behaviour. Besides, real masonry structures are cracked. A different approach is needed and it was used indeed when this type of structures were designed during the 18th. and 19th. centuries. Since the 1960's Professor Heyman has rigorously introduced the theory of masonry structures within the frame of Limit Analysis, and has clarified many aspects of the analysis of masonry architecture.

To teach a new theory (in fact a forgotten one) presents serious difficulties. Not the least is that the listeners (students, practicing architects or engineers, even professors...) must 'forget' the usual frame of reference (elastic analysis, framed or trussed structures, etc.) and contemplate, as did for example the gothic masters, a masonry building as a "heap of stones" in equilibrium under its own weight. But, one can add to his or her knowledge, but not subtract to it. In fact, we must reconcile the intuition of the old master builders with the teachings of modern structural theory.

The theory can be studied but, how to teach the

intuition, this feeling of the behaviour which has a fundamental importance in structural analysis and design? After more than fifteen years of teaching masonry structural behaviour I have found the use of physical models of extraordinary help.

I do not mean the complicated models of laboratory, made by skilled workmen, but very simple models that the students may replicate at home for experiment, study and reflection. I use normally only two types of models.

The first is Hooke's hanging chain. The second is a 'plane' block (voussoir) model made of thick cardboard. It is a personal invention, an idea which occurred to me when, at the beginning of my studies of arch behaviour, I was struggling with three dimensional models. It applies to arches or masonry structures of any kind as far as its thickness in one direction could be considered uniform: barrel vaults, but also buttresses or flying buttresses, double arches, etc.

The paper will present the use of this two basic models: 1) for the teaching and appreciation of the fundamental assumptions; 2) to assure a better understanding of the Fundamental Theorems of Limit Analysis applied to masonry structures; 3) to study and understand the basic crack configurations of masonry arches and vaults.

But to appreciate the use of models, a brief summary of the essentials of masonry structural theory should be given beforehand (for an excellent exposition see Heyman 1995).

THE THEORY OF MASONRY STRUCTURES

The theory of structures uses only three types of equations: equilibrium, material and compatibility. The way these equations are managed depend on the type of structure and material. The conventional theory of structures was developed during the XIXth century to cope with the new materials and the new types of structures invented: frame or trussed structures made of iron, steel or reinforced concrete. Of the three fundamental structural criteria (strength, stiffness and stability), strength was considered to govern the design. The approach was 'elastic' following the ideas of Navier (Heyman 1998). This approach is not adequate to understand the behaviour of masonry structures. In fact, a different theory developed before, independently, for masonry arches and vaults during the XVIIIth and XIXth centuries. This theory was swept away by the elastic approach. 'Navier's straitjacket' conditioned structural thinking until the advent of plastic theory. However, the old theory was basically correct and it is a fact that was used successfully during two centuries. The more general frame of plastic theory permits to incorporate the old masonry theory within its frame.

The 'Aold' theory became 'new' and the elastic approach (maybe disguised behind a complicated FEM program) should considered an outdated approach.

The material masonry

A masonry building is a heap of stones bond together in a certain way, with or without mortar, to produce a certain geometrical form. The adherence provided by the mortar, if it exists, is negligible and as a result the 'material' masonry (in fact a composite material) must work in compression. The form is maintained due to the friction forces generated between the stones by self-weight, and, as the friction coefficient is very high, sliding does not occur. Finally, stress levels are quite low and there is no need to make strength calculations (masonry may be assumed to have an infinite strength).

These observations form the basis of the behaviour of masonry. Any master mason would have accepted them as obvious. They formed the point of departure of the calculation of masonry arches and vaults during the XVIIIth and XIXth centuries. Professor

Heyman used them as the 'principles of limit analysis of masonry structures'.

Equilibrium: lines of thrust

The condition that the masonry must work in compression imposes a severe geometrical limitation: the internal forces must be transmitted within the masonry. In every section the point of application of the stress resultant must lie within the lines (or surfaces) of extrados and intrados. The locus of these points forms a curve, the *line of thrust*. In a masonry structure the lines of thrust must lie wholly within the masonry. In fact, the line of thrust is an abstract concept (as, for example, the centre of gravity); it is only a way of representing the equilibrium equations. The drawing of the thrust line permits to check that the essential property of the material, working in compression, is respected. In a buttress subject to a certain external thrust there is only one line of thrust and the problem is statically determined. In an arch, the two set of equations (equilibrium and material) are not enough to determine the position of the line: there are, in general, an infinite number of lines of thrust in equilibrium with the internal forces within the masonry.

Cracks and hinges

The material is supposed to have infinite strength and the sliding failure is impossible. In these conditions when the thrust (the compressive stress resultant) touches the limit of the masonry a 'hinge' forms. In a real arch this hinge is seen in the form of a 'crack': the joint opens and the contact must be, geometrically, in one point (in fact not in a mathematical point but in an 'engineering' point of small finite dimension). The possibility of cracking is a fundamental property of masonry. It permits, for example, that an arch may adapt itself to any small movement of its abutments. The abutments of the arch on the figure have given way slightly; the arch cracks in three points, and the resultant 'three hinged' arch is a perfectly stable structure.

The position of the line of thrust is now determined. But any new movement will change the position of the line of thrust, resulting in new equilibrium conditions (the thrust of the arch will change) and a

new pattern of cracks (always conducing to a isostatical state). In a real arch these kind of movements are unforeseeable and, essentially, unknowable. Small settlements of the soil, changes of temperature, an impact load, etc., will conduce to small movements of the abutments. It is impossible to know the 'actual' state of the arch nor to predict the possible changes in cracking. But cracks are not dangerous; on the contrary, the possibility of cracking is precisely which gives 'plasticity' to masonry structures.

Collapse of arches and the Fundamental Theorems of Limit Analysis

A masonry arch built with a material of infinite strength can collapse, and this may seem strange to a modern architect or engineer. In fact, when the load distribution produces an equilibrium state with a sufficient number of hinges which form a *mechanism of collapse*, the structure will fail. The collapse does not involve an strength failure, but an stability failure. It is the forming of a sufficient number of hinges which results in the collapse. This form of collapse was first demonstrated at the beginning of XVIIth century but, of course it was known by the old master builders. An arch collapses in the same way as an steel frame, forming hinges. The Fundamental Theorems of Plastic or Limit Analysis can, then, be applied to masonry structures. This fundamental discovery is due to Heyman (1966).

The Safe Theorem and the 'Equilibrium approach'

The most important of the Fundamentals Theorem is the Safe Theorem: if it is possible to find a distribution of internal forces in equilibrium with the loads, which does not violate the yield condition of the material, then, the structure is safe (it will not collapse). The main point is that this distribution of internal forces need not be the 'real' or the A_{actual} , it only need to be possible. If it exists, the structure, before collapse, will find it and remain safe. The Safe Theorem ha a corollary of paramount importance: it is possible to work only with two of the structural equations, equilibrium and material. It leads to what professor Heyman calls the *approach of equilibrium*, and approach which cuts the 'Gordian knot' present-

ed by the question of what is the actual state of the structure. It is impossible to know the 'actual' state, because of its intrinsically ephemeral character, but it is possible to ascertain the safety of the an structure without making non-verifiable assertions (about its boundary conditions, etc.).

The task of the analyst is not to find the actual equilibrium state, but to find reasonable states of equilibrium for the structure under study. In fact, this has been the approach of all the great architects and engineers. It was implicit in the "geometrical design" of the old master builders (Huerta 2004). It was explicit in the design work of Maillart, Torroja, Nervi, Candela or Gaudí, to cite only a few great engineers and architects.

In masonry arches the application of the equilibrium approach is straightforward: a distribution of internal forces in equilibrium is represented by a certain line of thrust, and this line must lie within the masonry to account for the properties of the material. An arch is safe if we can draw a line of thrust inside. For self-weight this leads to a geometrical statement: the arch must have a thickness which permits this, it must have, then, a certain geometrical form and this form is independent of size.

The safety of masonry arches

The safety is a matter of geometry but, how to measure it? Heyman (1969) proposed a geometrical safety coefficient resulting of the comparison of the actual geometry of the arch with the geometry of the limit arch, an arch of the same profile as the original, but which has the minimum thickness to contain a line of thrust. The limit arch is in a mathematical, unstable, equilibrium and will collapse. It represents the starting point for the designing of a safe, thicker, arch. The geometrical safety coefficient represents the relationship between the thickness of the actual arch with that of the corresponding limit arch. Its concrete value is an empirical matter, but it appears that a value of 2 is convenient in most cases.

To obtain the exact value of the thickness of a limit arch is a complicated mathematical exercise and, therefore, to ascertain the exact value of the geometrical safety coefficient may require long calculations. However, to establish a lower limit is very easy. Suppose we want to check that the geometrical coefficient is at least 2 for a certain arch. For this, it

is only necessary to be able to draw a line of thrust within the middle half of the arch. The same procedure will be used if the analyst decide to check for a coefficient of three: this time the problem is simply to draw a line of thrust within the middle-third. In general, historical arches are very safe and it is not difficult to draw these lines.

Sometimes, the exact value must be calculated (for example, to know what is the limit load which can cross a bridge), but in most cases the method suggested functions pretty well (and it was used, without knowing the Fundamental Theorems, in the second half of the XIXth century).

SIMPLE HANGING MODELS

Hooke's idea

Robert Hooke (1675) was the first to give a correct analysis of the behaviour of masonry arches. He solved the problem making an analogy of a well

known structure, the hanging chain or cord. 'As hangs the flexible line, so but inverted will stand the rigid arch' (Fig. 1 (a)). What is tension in the cable will be compression in the arch and the absolute value of the internal forces is identical.

Hooke was not able to deduce the equation of the catenary, but the analysis was not the mathematical exercise but the realization of the identical behaviour of two apparently different structures, as has been pointed by professor Heyman. A few years later another English mathematician, Gregory (1697), completed the assertion in a crucial way: the catenary is the true form of an arch and if arches of other forms stand it is because 'in its thickness some catenaria is included' (Fig. 1(b)).

It is much simpler to think in terms of hanging cables than in terms of arches. Hanging models were used also at the end of the XVIIIth century to demonstrate the behaviour of masonry bridges, for example by Thomas Young (1807).

Gaudí made extensive use of hanging models for the design of arches and vaults (Huerta 2003). (For a

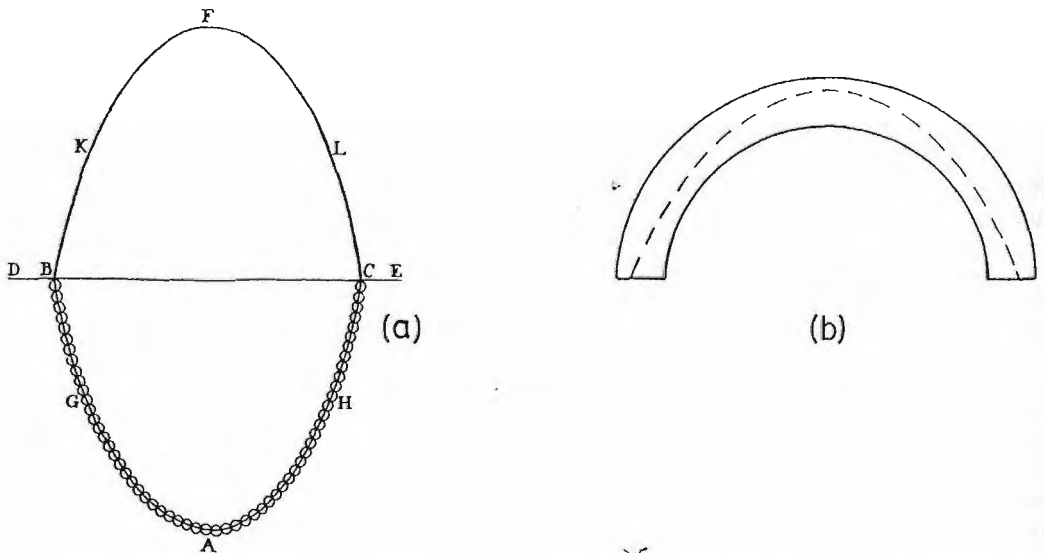

Figure 1
Hooke's analysis of the arch (Heyman 1995)

review of the use of hanging models in arch and vault design, see Graefe 1986).

Description and functioning of the model

The material is a simple chain that can be acquired in any hardware store. The hanging chain takes the form of *catenary* and this is very nearly the form of the line of thrust of an arch made of equal voussoirs (the best mathematical study of lines of thrust in Milankovitch 1907).

The intention is not to make an exact calculation (with the values of the thrusts etc.), nor it is to obtain certain forms in the design (as Gaudí did), it is to have a model to demonstrate some of the main points of the structural theory cited before, to 'think with the model'. To relate the hanging chain with an arch of finite thickness we will draw the arch in a cardboard. The arch must be inverted to show the relationship with the chain.

'PLANE' BLOCK (VOUSSOIR) MODELS

Block models of arches

Models of arches and vaults have been made since antiquity. It was a common practice to learn stonecutting, to make scale models with the voussoirs cut in soft stone or gypsum. Leonardo (ca. 1500) made some attempts to study arch behaviour with the help of models, without arriving to a theory. Danyzy (1732), Fig. 2, made the first experiments destined to demonstrate the correct form of collapse of arches, employing small models of arches made of gypsum (an excellent outline of the collapse theory of arches and the use of models in Heyman 1982). However the use models does not guarantee the arrival to a good theory, and there are many examples in the history of arch theory. To cite but one example, Bland (1839) made many models of arches and buttresses without understanding the true principles which explained the observed behaviour.

The problem with spatial block models is that the joints must be very precisely cut; if this is not so, the blocks tend to press in only certain points and the resulting behaviour (many times with slide-rotations of blocks etc.) deviates greatly from that of a real arch, where the process of construction preclude the

occurrence of such phenomena. A successful spatial voussoir arch model can be constructed only by an experienced workman in possession of adequate tools. On the contrary, the 'plane' block model proposed may be made by anyone with a moderate skill in handiworks. The main utility of block models is to observe the different patterns of cracking in arches. However, they may be used to study, also, complex phenomena.

Description and functioning of the model

The arches (maybe with buttresses) are made of blocks cut from a thick cardboard. A thickness of 1.5 mm is recommended. A thinner cardboard may not be perfectly plane; if it is thicker it is difficult to cut the joints perfectly plane. It is better to make the drawing first on the cardboard and then cut the blocks. It is not convenient to divide the arch in too many blocks; this will only complicate the process of mounting and the interpretation of the observed behaviour. A number of, say, 10-12 blocks for a whole arch is adequate. Of course, there is ample space for experimentation; these recommendations are the fruit of several trials along the years.

It is needed also a glass with a paper at the back to contrast the figure of the arch. It is better a plain, normal, glass; glasses with an anti-reflecting surface present normally a higher friction. At the base of the glass a continuous strip of cardboard should be glued. This is the basement for the arch. Then the glass is mounted on a lectern. The lectern should be in a position with a very low angle, so that the voussoirs do not slide. Now, the arch can be mounted. Normally it is not necessary to use a 'centering'; it is easy to mount the blocks one after the other, beginning by both springings and meeting at the keystone. It is not necessary that the blocks fit perfectly in this phase. When the arch is closed, the glass is lifted gently and the lectern is raised to a position with an inclination of, say, 65°-70°. Carefully the glass with the arch on it is placed over the lectern. Now it is possible to see how the blocks are pressing one against the other. In this moment corrections on the position of the blocks may be made to obtain an arch perfectly 'constructed'. (Fig. 3)

The physical principle involved is evident. The weight of each block acts vertically. As the block is supported by the inclined surface of the glass, this

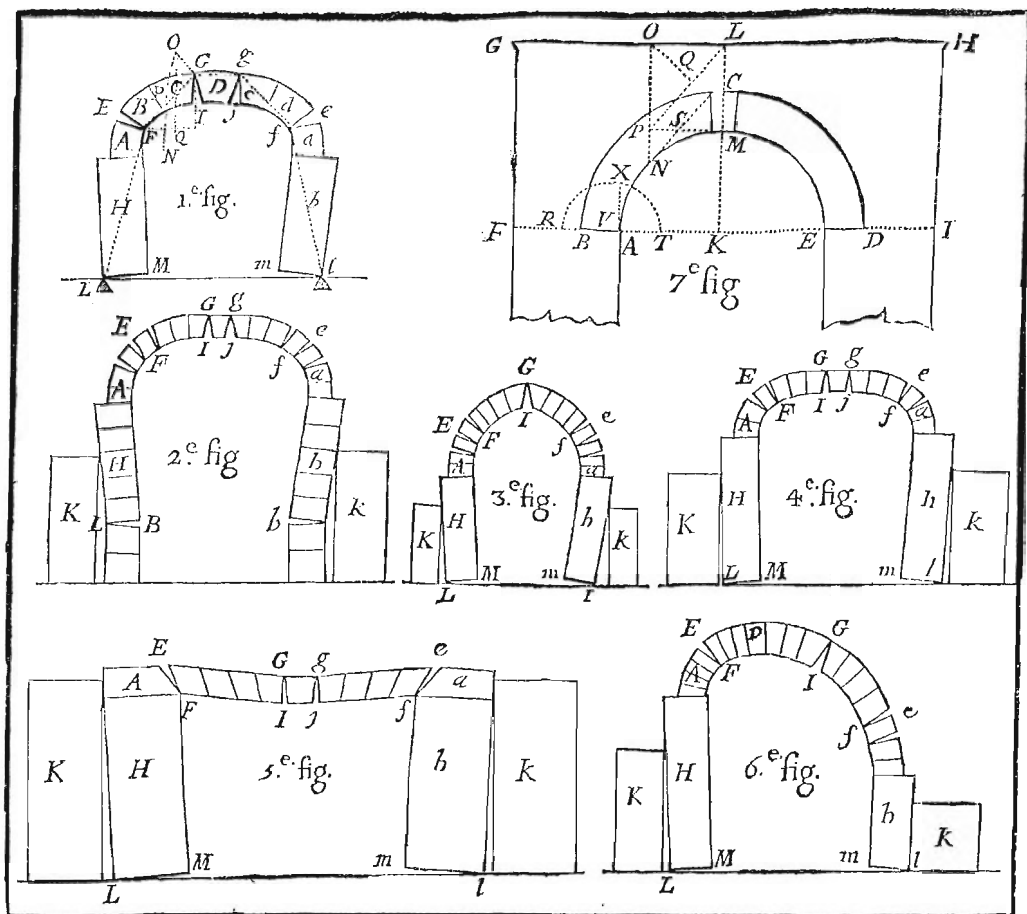

Figure 2
First experiments on the collapse of arches with small gypsum block models (Danyzy 1732)

force may be resolved into two other forces: one normal to the surface of the glass and the other contained within its surface.

When the inclination of the glass is well above the angle of friction between the cardboard and the glass, all blocks tend to slide downwards and these forces are proportional to the gravity forces. The cardboard arch behaves in exactly the same way as an spatial arch (or barrel vault) of the same profile. (Of course, when the movement is not entirely vertical,

some friction forces may arise, but they are very low and do not affect in general the fundamental behaviour.)

It would have been appreciated during the process of mounting the arch, that any small movement of the abutments or blocks leads to some 'cracking', the blocks forming some hinges. If the handling is not correct, occasional sliding may be observed. Moving the abutments, these cracks may be closed.

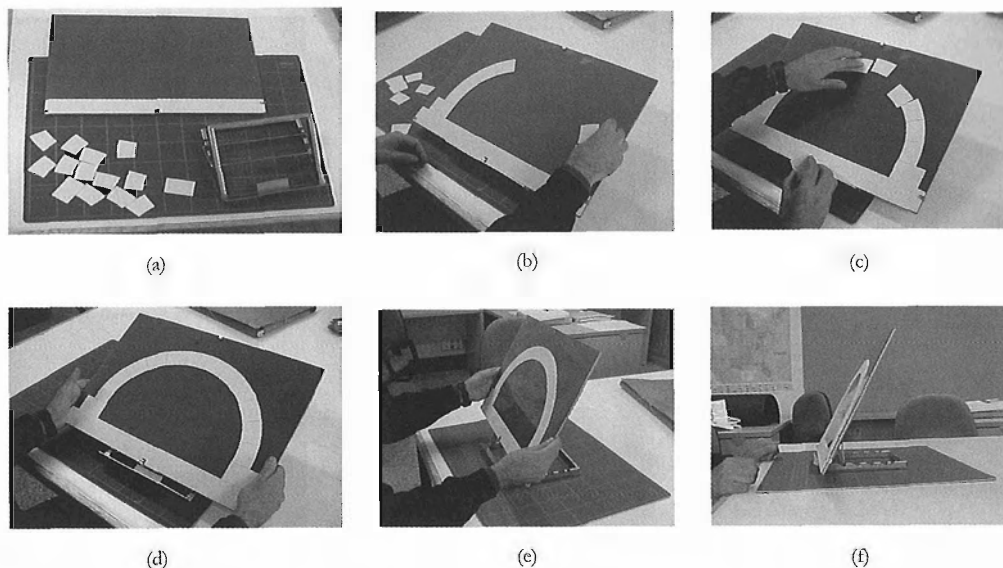

Figure 3
The 'plane' block model of cardboard

EXPERIMENTAL DEMONSTRATIONS

In what follows we will make a series of assertions which can be checked immediately employing the hanging chain models. Reference will be made to the figures of the experiments.

Equilibrium

1) The chain represents a certain possible state of equilibrium for the given loads.

2) There are infinite chains in equilibrium with the same loads.

3) A variation of the loads results in a change of the form of the chain.

[Fig. 4 (a) to (c); Fig. 6 (a); Fig. 7; Fig. 8 (b).]

Material

4) The masonry must work in compression; this implies that the chain must be within the arch

5) The use of hanging models provides an automatic check on this essential property of masonry: it is impossible that a chain or cable works in compres-

sion (i.e. the model guarantees that the masonry never will be in tension).

[Fig. 4(a) to (c); Fig. 7; Fig. 8 (b).]

Equilibrium + material

6) There are still infinite possible chains (states of equilibrium) within the arch.

7) There are two extreme positions of the chain, which corresponds to maximum and minimum height of the chain and, consequently, maximum and minimum thrust.

8) It is not possible to calculate the actual thrust of the arch, but it is possible to fix the upper and lower limits to its value.

[Fig. 4 (a) to (c); Fig. 7; Fig. 8 (b).]

Cracks and hinges

9) When the chain touches one of the limits of the masonry (lines of extrados or intrados) a hinge forms. The hinge will manifest itself in a real arch in the form of a crack. The formation of the hinge depends on the characteristics of the material: infinite com-

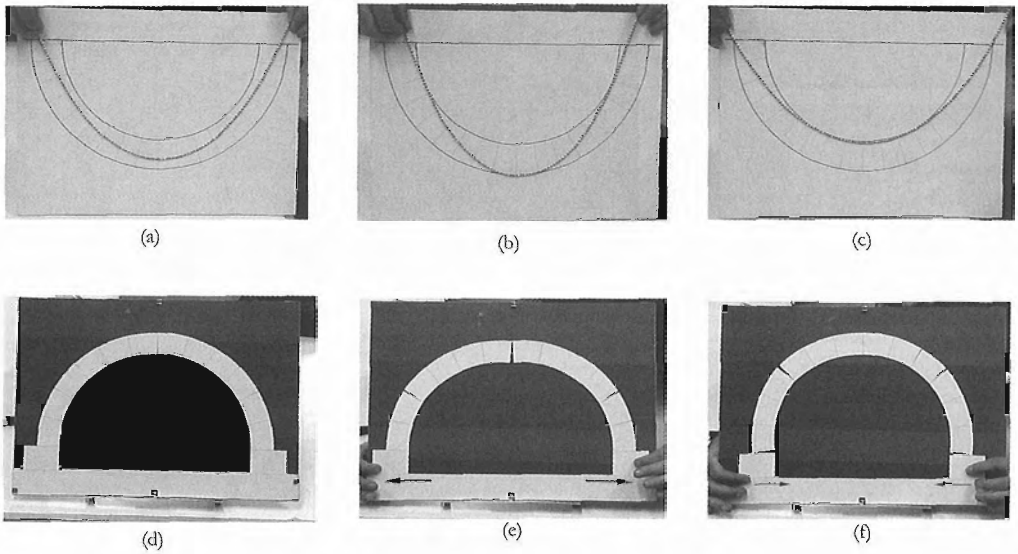

Figure 4
Semicircular arch. Equilibrium. Basic crack patterns

pressive strength, zero tension strength, impossibility of sliding.

[Figs. 2, 4, 6, 8, 9, 10]

Response to a movement of the abutments

10) After the decentering, a masonry arch will thrust against the abutments and they will give way slightly. The span consequently increases and the arch must accommodate to the new situation by forming hinges or cracks: three cracks develop: one at the keystone and two on the haunches.

11) These cracks determine the position of the chain/line of thrust which must pass through the hinges. In the above mentioned case, the chain takes a position corresponding to the minimum thrust. The state of the arch is now an isostatic three-hinged arch and internal efforts may be calculated with only the equilibrium equations.

REMARK 1: Cracking is NOT dangerous; it is the only way the structure has to cope with an 'aggression' of the environment.

REMARK 2: A slight further movement outwards will not affect the value of the horizontal component of the thrust.

REMARK 3: The cracking is 'reversible': if the

abutments approach to reach the original position the crack will close. It is possible to move forwards and backwards the abutment of the model without consequences.

In bridges and buildings this may occur as a result of seasonal changes in soil conditions, for example. [Fig. 4 (d) and (f)]

12) When the two abutments approach and the span is reduced the arch crack again and the hinges are disposed following the line of maximum horizontal thrust. The two superior hinges are equivalent to one as they both open upwards (in a real arch one of them will close).

The arch is again three-hinged and the thrust may be calculated readily. [Fig. 4 (e)]

13) Any other movement of the abutments will lead to a different cracking. As the base of each abutment has three degrees of freedom (two displacements and a rotation) the number of possible combinations is quite large. [Fig. 5]

Collapse of arches

14) The addition of a point load to an stable arch will distort the form of the line of thrust. For a certain

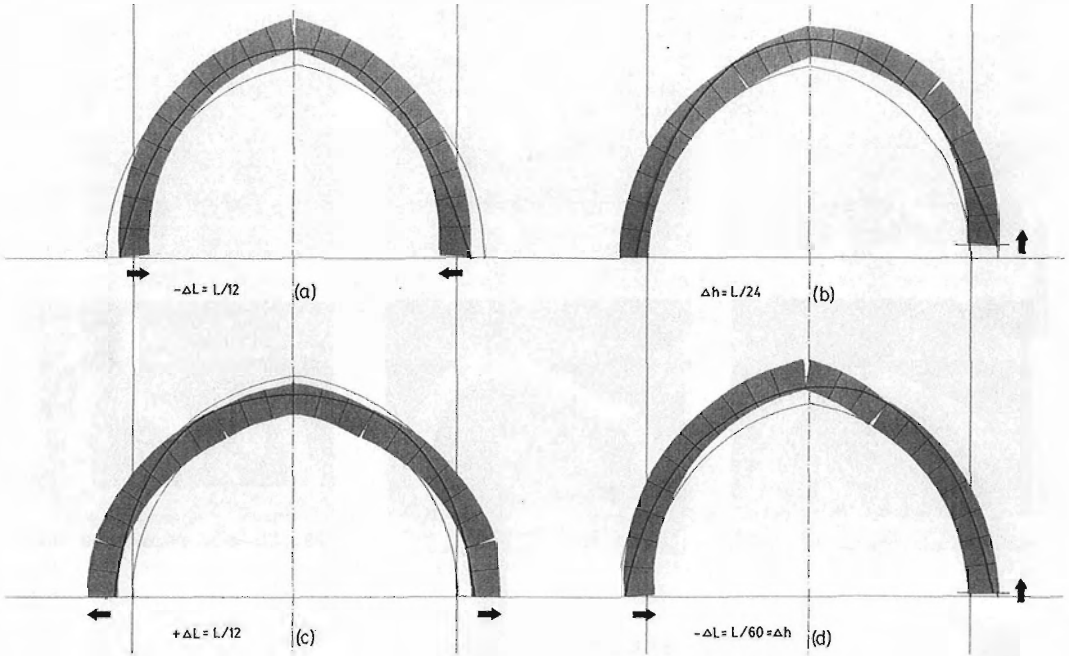

Figure 5. Response of a pointed arch to movements of the supports. Cracking and lines of thrust

value of the load the line of thrust will be just contained within the arch, touching in four points. The correspondent four hinges form a mechanism of collapse.

REMARK 4: The collapse depends on the formation of a sufficient number of hinges. It does not involve a strength failure (the cardboard blocks present no damage or distortion): it is a stability failure.

REMARK 5: It is precisely the same form of collapse of steel frames. The Fundamental theorems may be 'translated' to masonry when the properties of the material guarantee this form of collapse (infinite compressive strength, zero tension strength, impossibility of sliding). [Fig. 6]

Safety

15) The Safe theorem states that an arch with a possible equilibrium state which respect the material yield condition (work in compression), i. e., an arch with a chain inside is *safe*: it will not collapse.

16) For self weight, the form of the hanging chain

depends, for self-weight, on the form of the arch. The safety depends on geometry and not in size.

REMARK 6: Safe Theorem. A safe arch, an arch in which it has been possible to draw a line of thrust, will not collapse, for whatever movements we induce in the abutments, provided that these movements are 'small', i. e., that the equilibrium equations have not changed, i. e., the overall geometry of the arch is not distorted.

REMARK 7: The model may be considered as an empirical proof of the Safe Theorem, as it is impossible to produce the collapse of an arch by producing any set of small movements.

REMARK 8: Though the Safe Theorem applies only to small movements, the model shows that a voussoir arch may withstand very large movements, unacceptable for example for a steel or concrete modern structure. (Evidence of such large movements can be found in places where the soil suffers great movements, as is the case in México DF where it is easy to find masonry churches with enormous deformations which have stood for several centuries.) [Fig. 4 (a) to (c); Fig. 5; Fig. 7; Fig. 8 (b).]

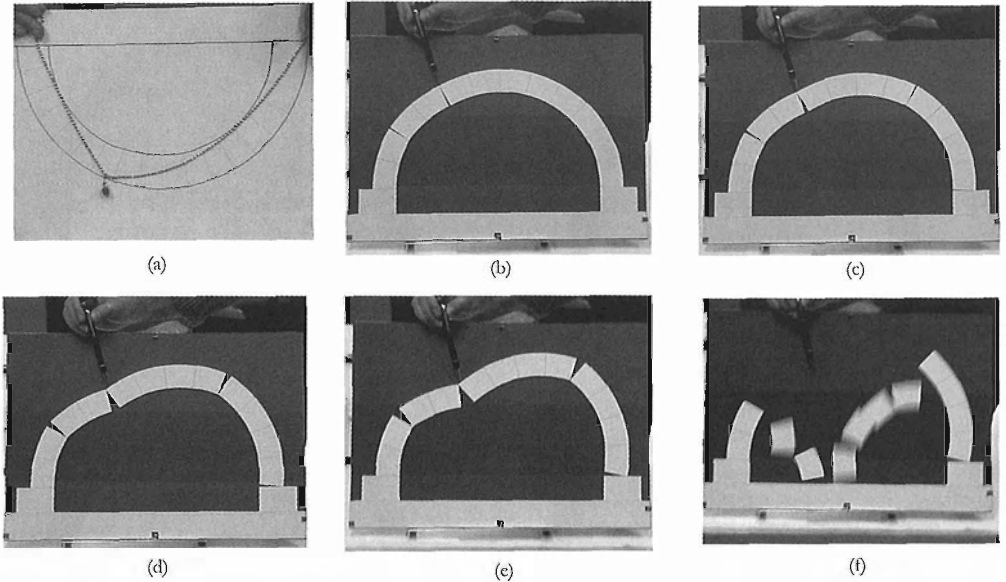

Figure 6
Collapse of a semicircular arch under a point load

Limit arches

17) as the form of the chain and that of the arch are different, if we shrink the thickness of the arch we reach a point where there is only one possible chain within the arch. This is the *limit arch*.

18) for an arch of uniform thickness with a certain profile, the limit arch is characterized by a relationship between the span and the thickness. For a semicircular arch $s/t \approx 18$, nearly; for the pointed arch in figure $s/t \approx 22$. [Fig. 7 (b) and (d)]

Geometrical coefficient of safety

19) The limit arch provides essential information for the assessment of the safety of arch of the same form. A geometrical coefficient of safety (Heyman) may be defined: the relationship between the thickness of the real arch to that of the corresponding limit arch. [Fig. 7]

Upper limit to the geometrical coefficient of safety

20) To demonstrate that the geometrical coefficient is at least equal and in general greater than a certain value n ; it is sufficient to be able to draw a line of thrust within an arch of the same form with a thickness t/n , being t the thickness of the real arch. For example, for a coefficient of 2, a line must lie within the middle half of the section of the arch; for a coefficient of 3 a line must lie within the middle third. [Fig. 7 (a) and (c), for a coefficient of nearly 2]

COMPLEX PROBLEMS

So far the two type of models have been used to make evident th

e most important theorems and corollaries of the theory of the masonry arch. The same models may serve to study complex problems.

When the analyst is faced with a new type of struc-

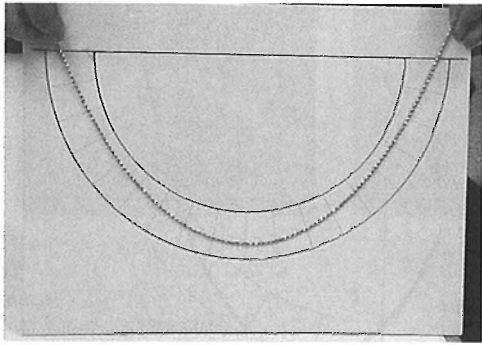

(a)

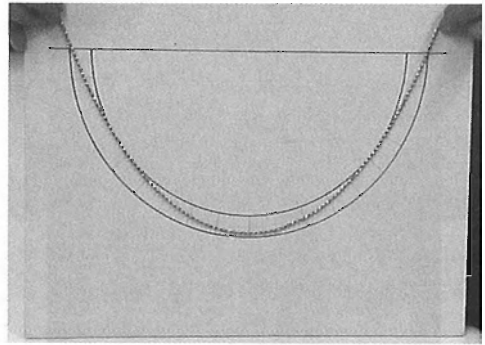

(b)

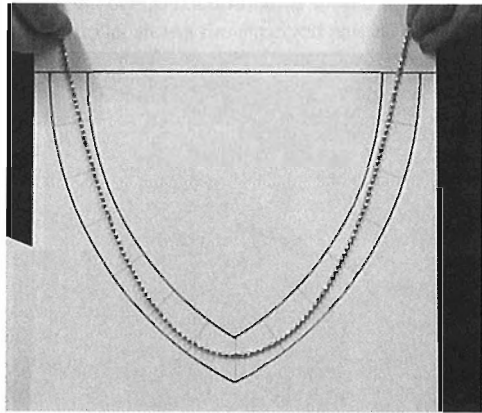

(c)

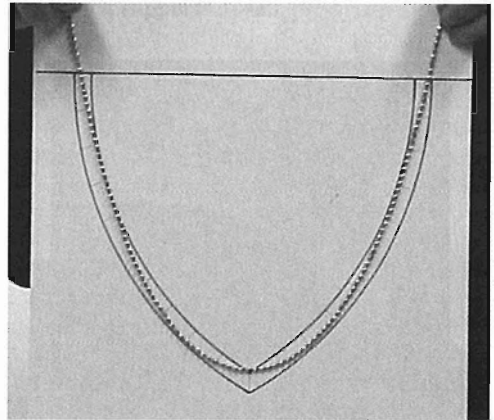

(d)

Figure 7
Limit arches and the geometrical safety coefficient

ture, it will be very useful to use the models to examine the problem qualitatively before doing any calculations. In fact, the models may well indicate an unexpected behaviour. In what follows some examples will be shown.

Flying buttress: sliding at the head

A flying buttress is not half an arch, but an arch with the supports at different height. When the buttress

where the lower part abuts gives way slightly, the flying buttress must crack but, in what way? Consider the problem in relation with idealized buttress of Fig. 8 (a). After looking at Fig. 4 one may expect a similar crack pattern. In fact, the hanging model of Fig. 8 (b) makes evident that this is not the case. Three hinges should form following the pattern of Fig. 8 (d). However, again unexpectedly, the first trial with the model gave the pattern of Fig. 8 (c): two hinges and sliding downwards at the head. Looking again at the form of the line of thrust (Fig 8 (b)) it is clear that

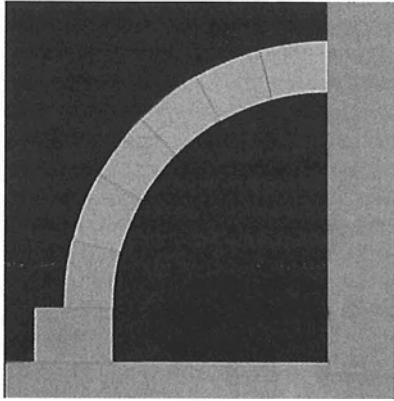

(a)

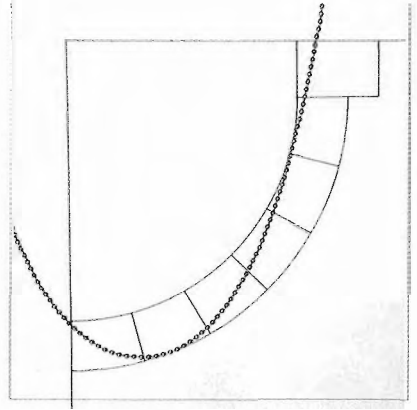

(b)

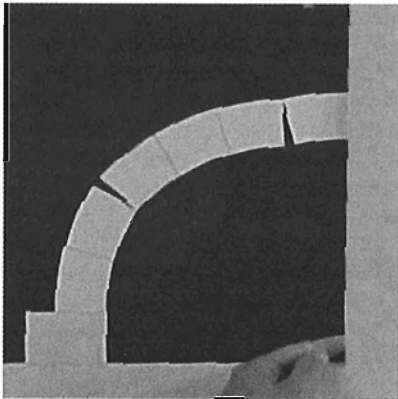

(c)

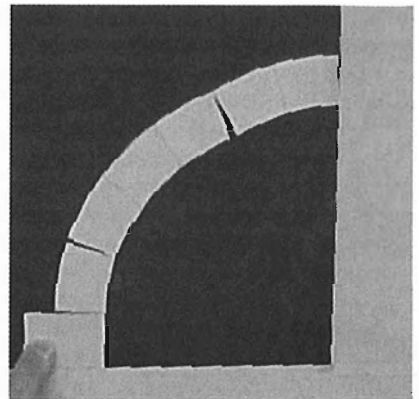

(d)

Figure 8
Study of a flying buttress

the inclination of the thrust with the wall may be out of the friction cone: the head of the buttress will tend to slide downwards.

The gothic builders placed there a little column or other similar device (the matter has been discussed by Heyman (1966), the best exposition of flying buttress behaviour). Evidence of sliding is not difficult to find (see for example, Smars 2000, 167). To avoid sliding in Fig. 8 (d) the friction was increased making small crease in the cardboard on both faces of the joint.

Double arches

Not infrequently a barrel vault is 'reinforced' by arches. Also, some brick bridges are made of successive rings, built concentrically one after the other. The model of such constructions may be that in Fig. 9 (a). What is the behaviour of such 'double' arches? Does they function as a single arch? A simple test with a model demonstrates that this is not the case. The two rings tend to slide and hinges form independently, Fig. 9 (b). There may be some transmis-

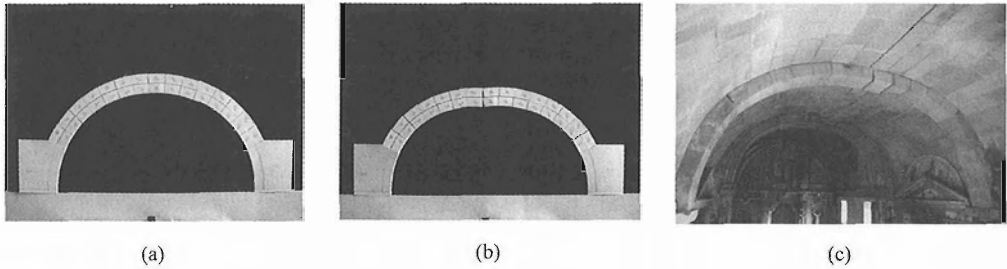

Figure 9
Behaviour of double arches

sion of load due to friction but it should be small. In case the model shows the expected pattern of cracks. This may be verified observing real vaults (Fig. 9 (c)). The matter has been studied with a complex mathematical algorithm by Melbourne and Gilbert (1995). The results are the same.

Arch which supports a wall

This is another frequent situation: an arch supports a wall of ashlar masonry (Fig. 10 (a)). The buttress system, as usual, gives way slightly, what is the expected pattern of cracks? This may difficult to study with

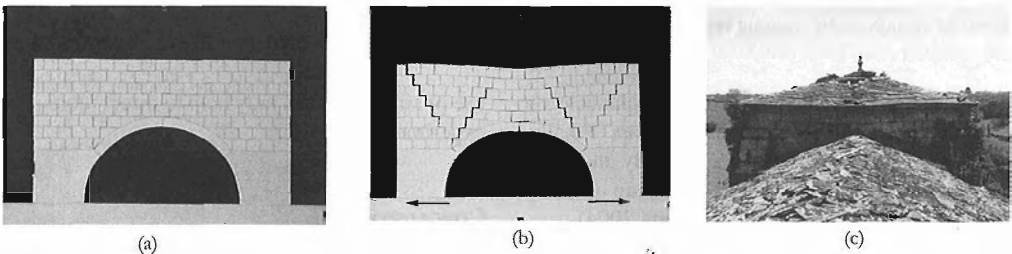

Figure 10
Arch which supports an ashlar wall.

the available engineering software. Again, a simple cardboard model (this time more time consuming) will make apparent the main features, Fig. 10 (b): inclined cracks forms, following the weaker lines of the bonding. The model may be compared with existing crack patterns, as in Fig. 10 (c), where the 'kink' in the cornice makes evident the movement. Cracks on the right and left sides are also evident. The wall is supported on the arch at the back of Fig. 9 (c).

Collapse of a masonry buttress

Traditionally the buttresses which support the arch or vault thrusts have been considered monolithic. In fact, a real buttress is made of separate stones and some cracking may be expected to occur. The first study of this possibility corresponds to the Spanish engineer Monasterio, ca. 1800 (Huerta y Foce 2003). The model demonstrates easily the most common mode of collapse (Fig. 11 (c)). The mode of Fig. 11

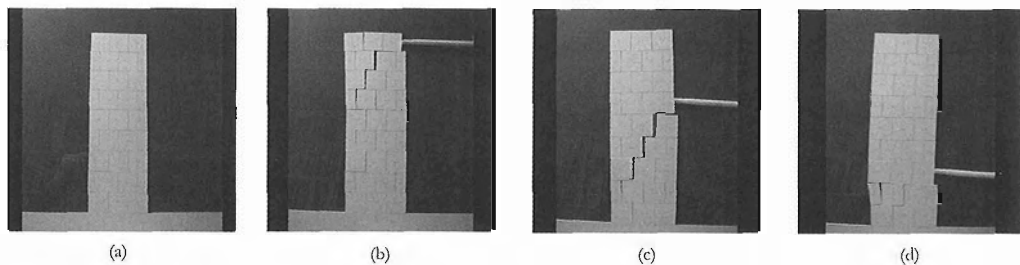

Figure 11
Possible modes of collapse of a masonry buttress

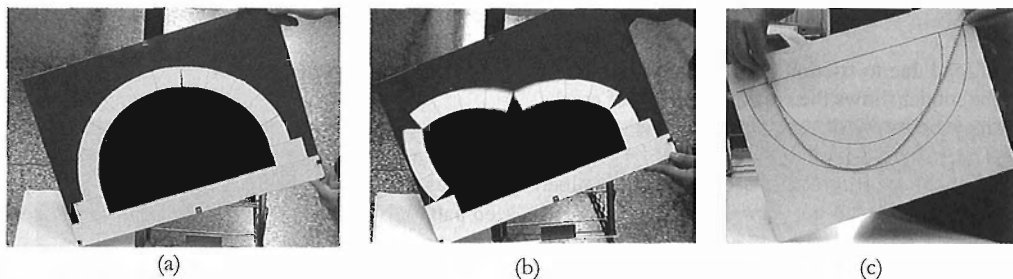

Figure 12
Collapse of an arch under constant horizontal acceleration

(b) suggest the convenience to build a pinnacle on top, a practice followed by gothic builders. Finally, the mode of Fig. 11 (d) is very unlikely in a real building. The theoretical aspect has been recently studied (Ochsendorf, Hernando y Huerta 2004).

Arch subject to a constant horizontal acceleration (seismic collapse)

Finally, the hanging and block models may be used to study possible collapse modes under seismic action. The effect of a constant acceleration may be simulated simply inclining the model: the collapse mode may be observed in the model of Fig. 12.

The same pattern has been observed in more precise experiments made with scale arches. I have found this idea of inclining block models in an article by Frei Otto (1986).

There is abundant literature on the seismic response of masonry structures. The laboratory material needed for experiments is quite sophisticated. Again, the

use of simple models may help to direct more precise experiments.

CONCLUSIONS

Two simple types of scale models, Hooke's hanging chain and the 'plane' block model, may be used to visualize the main assumptions of the theory of masonry.

The models may help to add to our experience of this kind of structures, which nowadays are no longer built in the western world. Also, the models help to think about the essentials of the stability of masonry arches.

'Playing' with them the student (I mean here a person who studies, in the University or maybe some years later as a professional) may check his or her understanding of the theory.

Finally, an experienced architect or engineer may find these models useful in order to study new problems.

REFERENCE LIST

- Bland, W. 1839. *Experimental Essays on the Principles of Construction in Arches, Piers, Buttresses*. . . London: John Weale.
- Danyzy, A. A. H. 1732. Méthode générale pour déterminer la résistance qu'il faut opposer à la poussée des voûtes. *Histoire de la Société Royale des Sciences établie à Montpellier*, 2: 40B56, 203B5. Montpellier: Jean Martel, 1778.
- Graefe, R. 1986. Zur Formgebung von Bogen und Gewölben. *Architectura*, 16: 50B67.
- Heyman, J. 1966. The stone skeleton. *International Journal of Solids and Structures*, 2: 249B79.
- Heyman, J. 1969. The safety of masonry arches. *International Journal of Mechanical Sciences*, 11: 363B385.
- Heyman, J. 1982. *The Masonry Arch*. Chichester: Ellis Horwood.
- Heyman, J. 1995. *The Stone Skeleton. Structural Engineering of Masonry Architecture*. Cambridge: Cambridge University Press.
- Heyman, J. 1998. *Structural analysis: a historical approach*. Cambridge, Cambridge University Press.
- Hooke, R. 1676. *A description of helioscopes, and some other instruments*. London.
- Huerta
- Gregory, D. 1697. Catenaria. *Philosophical Transactions of the Royal Society*, 19: 637B52.
- Huerta, S. 2003. El cálculo de estructuras en la obra de Gaudí. *Ingeniería Civil*, Núm. 130: 121B33.
- Huerta, S. y F. Focé. 2003. Vault theory in Spain between XVIIIth and XIXth century: Monasterio's unpublished manuscript 'Nueva Teórica de las Bóvedas.' En *Proc. of the First International Congress on Construction History (Madrid 20th-24th January 2003)*, editado por Santiago Huerta, 1155B66. Madrid: Instituto Juan de Herrera.
- Huerta, S. 2004. *Arcos, bóvedas y cúpulas. Geometría y equilibrio en el cálculo tradicional de estructuras de fábrica*. Madrid: Instituto Juan de Herrera.
- Melbourne, C. y M. Gilbert. 1995. The behaviour of multi-ring brickwork arch bridges. *Structural Engineer*, 73: 3947.
- Milankovitch, M. 1907. Theorie der Druckkurven. *Zeitschrift für Mathematik und Physik*, 55: 1B27.
- Ochsendorf, J., J. I. Hernando and S. Huerta. 2004. Collapse of masonry buttresses. *Journal of Architectural Engineering (ASCE)*, vol. 10: 88B97.
- Otto, F. 1986. Geschichte des Konstruierens. Was könnten die alten Baumeister gewußt haben, um Bauten entwerfen und bauen zu können? *Arcus*, 1: 3546.
- Smars, P. 2000. *Études sur la stabilité des arcs et voûtes. Confrontation des méthodes de l'analyse limite aux voûtes gothiques en Brabant*. Ph.D. dissertation. Katholieke Universiteit Leuven.
- Vinci, Leonardo da. 1974. *Códices de la Biblioteca Nacional de Madrid*. Madrid: Taurus.
- Young, Th. 1807. *A Course of Lectures on Natural Philosophy and the Mechanical Arts*. London: Joseph Johnson.

Seminario Internazionale
International Seminar

Teoria e pratica del costruire:
saperi, strumenti, modelli

Esperienze didattiche e di ricerca a confronto

*Theory and practice of construction:
knowledge, means, models*

Didactic and research experiences

Ravenna 27-29 ottobre 2005

a cura di / *edited by*
Giovanni Mochi

Volume 2

DAPT - DIPARTIMENTO DI ARCHITETTURA
E PIANIFICAZIONE TERRITORIALE
Università di Bologna



FONDAZIONE FLAMINIA
RAVENNA



Promosso da / Organized by

DAPT - Dipartimento di Architettura e Pianificazione Territoriale
Facoltà di Ingegneria di Bologna

Con la collaborazione di / with the collaboration of

Fondazione Flaminia Ravenna
Provincia di Ravenna
Associazione Edoardo Benvenuto
SEHC - Sociedad Española Historia de la Construcción
Centro Studi Labteco - DAPT

Con il patrocinio di / Supporting Institutions

Alma Mater Studiorum - Università di Bologna
Comune di Ravenna
AIAR - Associazione Architetti Ingegneri Ravenna
ARTEC - Associazione per la promozione del rapporto tra architettura e tecnica
Istituto Scuola Provinciale Edili - CTP Ravenna
Camera di Commercio Ravenna

Sostenitori / Supporters

ACMAR - Ravenna
COMACO ITALIANA Srl - Forlì
COLACEM Spa - Gubbio
COLABETON Spa - Gubbio

Comitato scientifico / Scientific Committee

A. Becchi, Università di Genova, Max Planck Institute for History of Science - Berlino, AEB
A. Barozzi, Università di Bologna, DAPT - P. Eco
M. Bertagnin, Università di Udine, EAG-CRATerre Grenoble
G. Carrara, Università Roma La Sapienza, ARTEC
M. Corradi, Università di Genova, AEB
G. Cuppini, Università di Bologna, DAPT - UNIADRION
E. Dassori, Università di Genova
A.C. Dell'Acqua, Università di Bologna, DAPT - ARTEC
F. Foce, Università di Genova, AEB
J.L. González Moreno-Navarro, Escola Técnica Superior d'Arquitectura de Barcelona
G. Gresleri, Università di Bologna, DAPT
R. Gulli, Università di Bologna, LabTeco - DAPT
S. Huerta, Escola Técnica Superior d'Arquitectura de Madrid, SEHC
J. Heyman, Cambridge University, AEB
J. Ochsendorf, MIT Boston
F. Nuti, Università di Firenze - ARTEC
G. Pascale, Università di Bologna, DISTART
S. Poretti, Università di Roma-Tor Vergata, DOCOMOMO Italia
P. Radelet de Grave, Università di Lovanio
L. Ramazzotti, Università di Roma-Tor Vergata
A. Sanna, Università di Cagliari, LABTERRA
J. Sakarovich, Université Paris V, École d'architecture de Paris-Villemin,
L. Zordan, Università dell'Aquila

Seminario Internazionale
International Seminar

Teoria e pratica del costruire:
saperi, strumenti, modelli

Esperienze didattiche e di ricerca a confronto

*Theory and practice of construction:
knowledge, means, models*

Didactic and research experiences

Ravenna 27-29 ottobre 2005

a cura di / *edited by*
Giovanni Mochi

Volume 2

DAPT - DIPARTIMENTO DI ARCHITETTURA
E PIANIFICAZIONE TERRITORIALE
Università di Bologna



FONDAZIONE FLAMINIA
RAVENNA

