

University of Groningen

The Organization of Intraspecific Agonistic Behaviour in the Rat

Koolhaas, J.M.; Schuurman, T.; Wiepkema, P.R.

Published in:
Progress in Neurobiology

DOI:
[10.1016/0301-0082\(80\)90024-6](https://doi.org/10.1016/0301-0082(80)90024-6)

IMPORTANT NOTE: You are advised to consult the publisher's version (publisher's PDF) if you wish to cite from it. Please check the document version below.

Document Version
Publisher's PDF, also known as Version of record

Publication date:
1980

[Link to publication in University of Groningen/UMCG research database](#)

Citation for published version (APA):

Koolhaas, J. M., Schuurman, T., & Wiepkema, P. R. (1980). The Organization of Intraspecific Agonistic Behaviour in the Rat. *Progress in Neurobiology*, 15(3), 247-268. DOI: 10.1016/0301-0082(80)90024-6

Copyright

Other than for strictly personal use, it is not permitted to download or to forward/distribute the text or part of it without the consent of the author(s) and/or copyright holder(s), unless the work is under an open content license (like Creative Commons).

Take-down policy

If you believe that this document breaches copyright please contact us providing details, and we will remove access to the work immediately and investigate your claim.

Downloaded from the University of Groningen/UMCG research database (Pure): <http://www.rug.nl/research/portal>. For technical reasons the number of authors shown on this cover page is limited to 10 maximum.

THE ORGANIZATION OF INTRASPECIFIC AGONISTIC BEHAVIOUR IN THE RAT

J. M. KOOLHAAS, T. SCHUURMAN and P. R. WIEPKEMA*

Department of Zoology, State University of Groningen, P.O. Box 14, 9750 AA Haren,
The Netherlands

(Received 17 June 1980)

1. Introduction

Animals interact with their environment by utilizing space and time in such a way that survival and reproduction are optimal. Part of this interaction is visible when animals perform movements or postures and produce sounds or smells. The behaviour involved consists of a large repertoire of separate elements, which may differ widely from species to species.

Two aspects of these elements will be stressed here:

- (1) they are more or less successful adaptations of the organism to relevant aspects of its specific environment, and
- (2) at least in the higher developed species many of these elements may be multi-purpose.

Insight into both aspects—the biological significance of the separate behaviour elements and the rigidity or flexibility of their performances and goals—can only be gained by observing the animals involved while living in their natural environment. Such information is badly needed, be it only in a qualitative form in order to design biologically meaningful experiments under often simple laboratory conditions.

Because of the often large adaptational differences between species we restrict this paper to intraspecific agonistic behaviour of male rats (*Rattus norvegicus*), as can be readily observed when they defend their territory.

This article is an attempt to summarize the “state of the art” of an ethological approach to the hormonal and central nervous organization of this agonistic behaviour. In order to appreciate the design of the experiments under often simple laboratory conditions, we want to briefly describe how wild rats live and behave.

2. Ethological Aspects

The behaviour of wild rats living under (relatively) free conditions has been described by several authors (Barnett, 1963; Calhoun, 1962; Lore and Flanely, 1977; Telle, 1966; Timmermans, 1978). They all present the same basic picture. Rats live in burrows in and around which one adult male dominates a small group of females and young rats. Non-group members are admitted into the territory except males older than about 3 months. Although it is mainly the dominant male who drives away intruders, a lactating female may do the same in the vicinity of her home burrow. A number of such territories form a colony often situated in the neighbourhood of some common feeding place. Outside the territories, neutral pathways exist where fighting is minimal and avoidance occurs.

In particular, the data of Calhoun (1962), who reported numerous fascinating incidents in the daily life of wild rats, indicate a large flexibility of the agonistic behaviour of territorial male rats. For instance, Calhoun observed a male transporting pieces of cake to its territory. While doing so the rat met an intruding neighbour male in its territory. The latter was chased away immediately. However, a few moments later both males ate

* Present address: Department of Animal Husbandry and Ethology, Agricultural University, Wageningen, The Netherlands.

side by side pieces of cake the first male lost outside his territory. No agonistic interactions were observed then.

Such and many other data show that in wild rats the rules that govern the occurrence of intraspecific agonistic behaviour are very subtle and depend on factors like place, context, individual recognition, time of the day and so on.

Since the agonistic behaviour of domesticated rats does not differ essentially from that of wild rats (cf. Blanchard *et al.*, 1975; Timmermans, 1978), we have to be prepared for a rich behaviour repertoire of the domesticated ones. Moreover, large differences can be expected between conspecific males having different (onto)genetical (Bronstein and Hirsh, 1976; Price and Belanger, 1977) or experiential (Luciano and Lore, 1975) histories.

Although lactating females may perform such agonistic behaviour towards intruders, it is mainly one male who safeguards the area, in particular during the reproductive period. This territorial behaviour contributes to more or less stable relationships among conspecifics living in the larger area of the whole colony.

We have focussed on this type of intraspecific agonistic behaviour, not only because of its biological relevance, but also since it can be observed easily under relatively simple laboratory conditions.

Peys (1977) showed that male rats from the age of 3 months and older may perform the complete adult agonistic behaviour pattern. Before that age fighting does occur, but in a playful manner only. For instance, it is not until they are 3 months old that mutual wounding during fighting of males occurs. Peys conceives this intermale agonistic behaviour as the start of territorial behaviour in young male. These data nicely fit the observations of Calhoun (1962).

In the light of the foregoing we studied territorial agonistic behaviour of male rats of 3 months and older; they were kept in large observation cages ($85 \times 60 \times 60$ cm³, front glass wall) together with one adult female. The males belonged to two strains, either Tryon Maze Dull S3 or WEzob; these animals readily perform social behaviour. Territorial behaviour was elicited easily when a strange adult male was added into this cage. All observations were made during the night hours of the rats, using dim lights during the observation. Before each confrontation the home female was always removed.

A first step is to make this agonistic behaviour measurable. This was reached by distinguishing a number of separate behaviour elements (movements and postures) that together form the behavioural make up of the home cage male directed at an intruder, or at least performed during the presence of the latter. These elements have a more-or-less stereotyped form and can be recognized over and over again (cf. Grant and Mackintosh, 1963; Lehman and Adams, 1977; Timmermans, 1978). By counting the frequencies and durations of the separate elements a quantitative picture of territorial agonistic behaviour is obtained.

First we shall present a list of those elements that together allow for nearly all the behaviour during an observation period. The elements were defined in such a way that no overlap was possible, while the animal always was doing something.

Behaviour elements used:

(1) *Rearing* (Rea). Standing on all legs or the hindlegs only; if sniffing movements occur they are in the air (see (2)). The head does not move (see (3)).

(2) *Sniffing* (Sn). Rapid movements of whiskers and nose close to a substrate (see also (10)). No locomotion.

(3) *Scanning* (Sca). Standing as during rearing, but now the head is moved slowly in a horizontal plane. No sniffing movements.

(4) *Grooming* (Gr). Face washing with the forepaws; licking, nibbling and wiping the fur, tail and paws with tongue and teeth.

(5) *Scratching* (Scr). Repetitive fast movements of the hindlegs directed at the head or flank. Each burst is closed by some nibbling at the toes of the hindleg used.

(6) *Resting* (Re). Lying down in a stretched or curled up position. Eyes open or closed. Yawning and stretching may occur.

(7) *Moving towards* (M.T.) Any locomotion reducing the distance between both rats. Sniffing may occur, while running speed is low or high (o.a. approach, chasing).

(8) *Moving away* (M.A.). As for (7), but now the distance between both animals is increased.

(9) *Fixating* (Fix). Only the forelegs are moved towards the opponent resulting in a fully stretched posture towards the latter. Sniffing may occur.

(10) *Investigating* (Inv). Sniffing movements at the fur of the opponent except its anogenital region (see (11)).

(11) *Genital sniffing* (Gsn). Sniffing movements at the anogenital region of the opponent. Locomotion may occur simultaneously.

(12) *Social grooming* (SGr). Nibbling the fur of the opponent. Sometimes it consists of pulling and biting the fur of neck and back region (aggressive groom).

(13) *Lateral threatening* (LT). Slowly moving in a sideways direction to or around the opponent; piloerection, arched back, body close to the substrate. The eye on the side of the opponent is often closed. The animal may keep distance but may also push away its opponent.

(14) *Upright posture* (U). The rat stands on its hindlegs in reaction to approach or upright or the opponent. They may hold on to each others forepaws. Piloerection in the dominant male. Eyes may be half closed, while teeth-chattering may occur.

(15) *Clinch* (Cl). Very rapid rolling, jumping and biting of both animals that are in close contact.

(16) *Keeping down* (KD). Standing over the opponent. Keeping it against the substrate. Piloerection mostly present.

(17) *Keeping off* (KO). Kicking movements with one of the hindlegs towards the opponent. Standing position. No piloerection (see (18)).

(18) *Submissive posture* (SP). Lying on the back during and following keeping down by the opponent. Kicking movements with the paws may occur. Ultrasounds (20–25 kHz) may be produced.

(19) *Mounting* (Mou). Mounting the opponent as in a male female encounter.

(20) "*Rest*" behaviour. All the rest of behaviour including eating, drinking, gnawing, digging.

It will be clear that not all the elements listed are typical of a male rat defending its home area against an intruder. Some of them will occur when the male is not or no longer interested in the intruder. Normally, however, the following happened.

As soon as the intruder male was put into the cage the home male became aroused and moved towards (approached) him. The first behaviour elements are then investigating and genital sniffing. Meanwhile the intruder explores the cage with rearing, sniffing and locomotion (cf. Colpaert and Wiepkema, 1976). In this first phase the home male performs much moving towards and some grooming (in particular face washing).

Soon the home male shows piloerection and moves towards the intruder while performing lateral threatening. This may be answered by keeping off and upright posture by the intruder. In the latter case the home male also takes this posture maintaining its piloerection. Threatenings are often followed by clinch.

These fights, mostly won by the home male, lead to much moving away (fleeing) of the intruder. However, soon afterwards the intruder stops moving away and takes an upright or submissive posture when approached. The home male stops most of its agonistic behaviour when the intruder remains passive or, of course, when the intruder disappears.

This global picture suggests a patterning of the agonistic encounters in that some behaviours occur more at the beginning, others towards the end (cf. Lehman and Adams, 1977). Before presenting a quantitative picture of this patterning we want to stress the differences in agonistic behaviour between the home and intruder male. The former taking the initiative performs much moving towards, lateral threatening and keeping down, whereas the latter reacts with much upright posture, keeping off and submissive posture. The home males do perform upright posture, but only while reacting to the

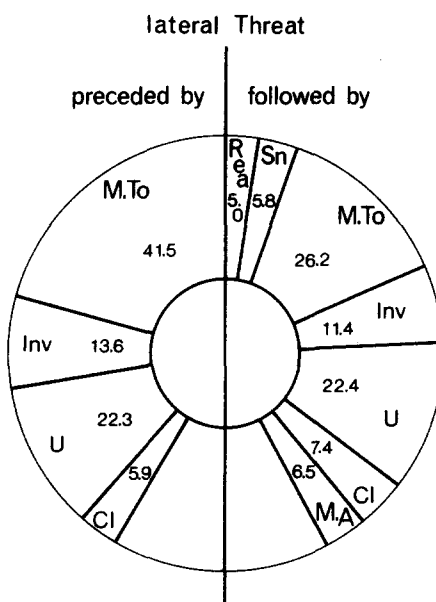

FIG. 1. Distribution (%) of predecessors and followers of lateral threatening. The radius of the inner circle represents the % duration of lateral threatening.

same behaviour of the intruder. Further, it is mainly and often exclusively the home males that show piloerection. This distinction lends support for a classification of agonistic behaviour into an offensive and a defensive category (cf. Blanchard and Blanchard, 1977; Lehman and Adams, 1977; Olivier, 1977). We shall focus on the offensive part.

The sequential patterning of the home male's offensive behaviour was examined in detail by Olivier (1977), while investigating the effects of ventromedian hypothalamic lesions on agonistic behaviour of male rats housed in the way described above. In one of his experiments he described the territorial agonistic behaviour of 42 intact WEZob males, while a smaller but adult male was put into the home cage of each of these males for a period of 10 min. The behaviour elements listed above were recorded. Each male was observed once a day on 5 successive days.

First Olivier made a transition matrix of all behaviour elements for the 42×5 observations periods. Such a matrix shows how many times each element is preceded or followed by each of the others. For one element, the distribution of predecessors or followers is shown in Fig. 1. The width of the inner circle indicates the frequency of the element involved, while the distribution of predecessors (or followers) is expressed as a percentage of all predecessors (or followers). Such figures underline the existence of a global sequence running from scanning to moving towards to lateral threatening to upright posture to clinch.

A more complete picture was obtained by calculating a preferential direction (P.D.) occurring between two directly succeeding elements. P.D. was defined as:

$$(\alpha - \beta)^2 / (\alpha + \beta) = X$$

where α = the number of observed transitions from A to B, and β that of B to A; P.D. = zero when $\alpha = \beta$; A and B are behaviour elements.

The outcome of these calculations is shown in the diagram of Fig. 2, representing the most striking directional patterns in the behaviour observed. It should be kept in mind that a thick arrow does not mean the absence of the reverse transition. In this diagram Olivier left out all P.D.s of those pairs of elements that had a low similarity. Roughly, a high similarity between A and B means that proportionally A and B precede and follow each other very much; cf. Morgan *et al.* (1976).

This complex of behaviour elements shown by the home male towards an opponent is called offensive behaviour, since it secures a specific area from intruders. We shall call

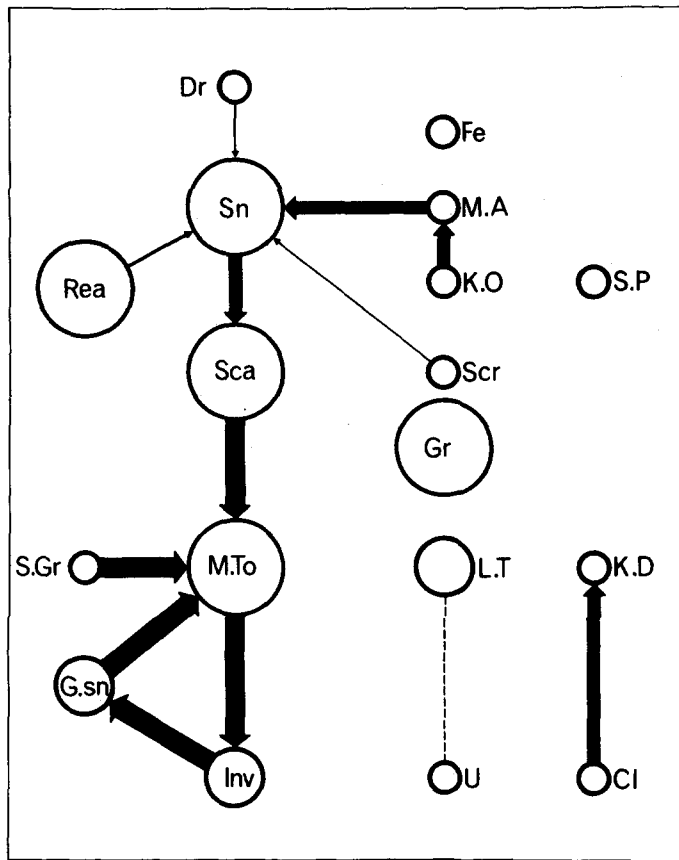

FIG. 2. Structure of the behaviour (preferential directions) of a male rat in the presence of a subordinate conspecific. The radius of a circle reflects the mean time spent on that behaviour element. The thickness of the arrows indicate the strength of the preferential direction.

this patterned collection of behaviour elements a behaviour system or a behaviour program.

The directionality found in offensive behaviour is a very common feature of many other behaviour systems distinguished by ethologists. A number of these systems have been called regulatory, since they are directed at the homeostasis of some aspects of the "milieu interne"—e.g. feeding, drinking, or thermoregulatory behaviour. Basically the regulation is determined by a comparison of the actual value of some internal parameters with its corresponding set point or standard. If the comparison reveals a difference a behaviour program is set in motion that specifically decreases that difference. For a recent discussion of pros and cons of such a model see Toates (1979).

In our opinion it is untenable to restrict regulatory systems to those that are directed at the homeostasis of the internal environment only. Regulation can equally well be connected with aspects of the external environment, as has been described by Baerends (1976) with respect to breeding behaviour in gulls. Accordingly, also offensive behaviour can be conceived of as a regulatory system by which an external parameter—presence or absence of conspecifics in a certain area—can be kept in a desired condition. For that purpose we assume that an experienced home defender has at its disposal a neuronal standard that is a very precise representation of a certain external area without strangers, that can be compared with the perceived reality. If the comparison results in a difference, offensive behaviour is released by which the external situation is brought back to its standard. Such a model has been put forward by Archer (1976), Toates and Archer (1978) and Wiepkema (1978).

Schematically the organization of territorial offensive behaviour can be represented as in Fig. 3. During his regular patrols the home male may detect an opponent inside its

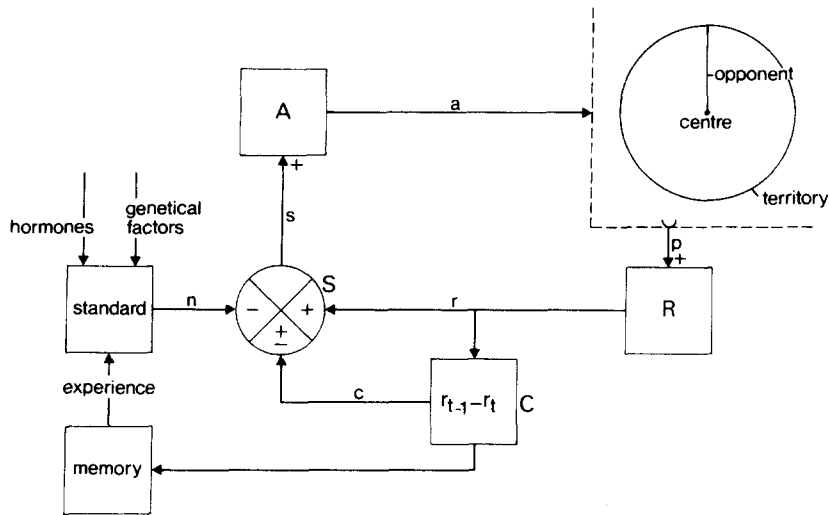

FIG. 3. Intraspecific agonistic behaviour as a regulatory system.

territory. This provocation (p) is perceived and processed in R . The result (r) is compared in S with the corresponding standard. If there is a difference, s will stimulate A , resulting in offensive behaviour (a). By this, the opponent may be driven away towards the boundaries of the territory, followed by a complete expulsion. Such a success normally enhances the intensity of agonistic behaviour (positive feedback effect), which in the model is realized by box C . In this box the change in r (r being higher the nearer the opponent is to the centre of the territory) over time is measured. If $r_{t-1} > r_t$ (r decreases) the output of C (c) becomes positive and enhances s , being the difference between n and $r + c$. The increased s intensifies the output of A , offensive behaviour. The reverse will happen when $r_{t-1} < r_t$ (r increases; i.e. the opponent approaches the centre following offensive behaviour of the home male). The processes occurring in C may change the standard via memory processes, while the same standard is also dependent on genetic and hormonal factors.

In this scheme territorial offensive behaviour comprises all those behaviour elements of the home male that somehow diminish the difference between the actual situation and its corresponding standard; or, in other words, contribute in one way or another to a removal of an opponent out of a territory.

We may consider this model as a simple physiological mechanism for offensive behaviour. For the sake of simplicity this mechanism has only a few inputs, one output and a minimal number of boxes each with a specific function within the mechanism. Despite its simplicity, the model behaves like a male territory owner does; it fights as soon as an unfamiliar male enters the territory provided a correct hormonal state and a good experience.

In the following we shall follow two of our research lines in the physiological analysis of this mechanism for agonistic behaviour in the rat: namely, the role of gonadal hormones and that of various brain structures.

3. Hormonal Aspects

A variety of studies suggest that gonadal hormones, especially testosterone (T) are involved in the facilitation and initiation of offensive behaviour in many species. It is beyond the aim of this paper to discuss all of them thoroughly. Yet a short discussion of these mainly correlational studies may be due here.

First, some data relate the onset of gonadal activity (steroid hormone secretion) to the onset of inter-male aggressive behaviour in puberal life. McKinney and Desjardins (1973) and Barkley and Goldman (1977) demonstrated that the onset of aggressive behaviour of

mice coincides with the first rise in androgen secretion. In the rat plasma T concentration rises strongly between 40 and 60 days of age (Resko *et al.*, 1968; Grotta, 1971; Ghanadian *et al.*, 1975; Moger, 1977). The onset of inter-male aggression in the rat (Calhoun, 1962; Barnett, 1975; Peys, 1977) runs parallel with this hormonal process.

A second line of correlation evidence is given by species that show a high level of intermale aggression only in the breeding season. In some of these species it was demonstrated that a high gonadal activity is restricted to this period. Gordon *et al.* (1978) showed this in the rhesus monkey. Also, the wild rat is a seasonal breeder, and a high level of intermale aggression is restricted to the breeding season (Calhoun, 1962; Barnett, 1975). The data of Kinson and Liu (1973) and Mock *et al.* (1975) suggest an annual cyclicity of gonadal activity related to the breeding season.

One additional point is that in most species the males (which have much higher plasma T levels than the females) are also more aggressive than females.

The above-mentioned correlational studies are supported by dozens of studies that demonstrated changes in the amount of intermale aggression resulting from manipulations of plasma T concentrations. Many studies with mice demonstrated that gonadectomy results in a decrease of inter-male aggression (e.g. Beeman, 1947; Bevan *et al.*, 1957; Leshner and Moyer, 1975). Androgen injections or subcutaneous implants could restore or maintain a normal level of inter-male aggressive behaviour in castrated mice (Beeman, 1947; Luttge and Hall, 1973; Owen *et al.*, 1973; Bowden and Brain, 1978). The same holds for the rat, although only a few studies are available (Barfield *et al.*, 1972; Christie and Barfield, 1979a).

From experiments in which T or testosterone propionate (TP) crystals were implanted in the brain of castrated rats or mice, we know that T is behaviourally active in the central nervous system. Bean and Conner (1978) and Bermond (1978) showed that such implants in the anterior hypothalamic-preoptic area of the brain of castrated rats activated intermale aggressive behaviour. Owen *et al.* (1974) got similar results with mice. Also, T receptors were demonstrated in several brain structures like the hypothalamus, preoptic area, septum, hippocampus, amygdala (Stern and Eisenfeld, 1971; Sar and Stumpf, 1972; Naess and Attramadal, 1974; Greenstein, 1979; Sheridan, 1978). However, the specific role of T in the functioning of these brain structures in offensive behaviour is as yet unknown. Although the above-mentioned studies all show that T in some way affects the level of offensive behaviour, it is not clear at which parts of the behaviour mechanisms this hormone exerts its influence. An intact pituitary-gonadal axis is certainly not an absolute necessity for offensive behaviour. For example, Barfield *et al.* (1972) and Christie and Barfield (1979a & b) demonstrated that castrated rats behaved less aggressively against intruders of their home cages than before castration, but these castrates still showed some fighting. In fact, almost all castrated residential rats still became dominant over intruders. So, after castration there is not a complete loss of offensive behaviour; the castrates are still able to fight effectively and inflict defeat to intruders of their home cages.

This result was confirmed in an experiment in which we studied the effects of castration and subsequent TP treatment upon offensive behaviour under two different experimental conditions. When tested in their home cages, castrated rats maintained a rather high level of offensive behaviour, although there is a slight decrease, compared to intact controls (Fig. 4). Even 2 months after castration the rats were still effective in defending their home cages against intruders, the latter ones were often badly injured. However, castration resulted in a rapid decrease of offensive behaviour during standard aggression tests in cages that were unfamiliar to the experimental animals, but familiar to the opponents/stimulus rats.

In unfamiliar cages fighting rarely occurred after castration. The slow and moderate decline of offensive behaviour in the home cage and the rapid and drastical decrease in unfamiliar cages is shown in Fig. 5 for lateral threatening. As soon as 2 days after castration, a significant drop (75%) of lateral threatening occurred. In the same castrates, when tested in the home cage, this decrease reached significance 42 days following

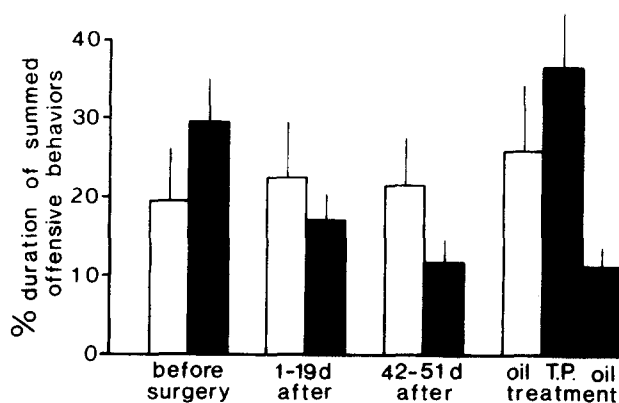

FIG. 4. Effect of castration and subsequent testosterone propionate (T.P.) treatment on offensive behavior towards an intruder of the home cage. Castrated rats ($n = 9$). Sham-operated rats ($n = 6$). Bars: s.e.m. 52 Days after castration 6 out of 9 castrates received daily T.P. treatment (0.75 mg), the remaining 3 and the shams got daily oil injections.

castration. The same Figure also shows that during TP treatment the performance of this offensive behavioural element increased rapidly to precastration levels in both test situations. Sham castration and oil injections did not affect lateral threatening. The very same pattern was also observed for other offensive behavioural elements like clinch and keeping down. Along with this, attack latency times increased in the home cages slowly after castration, whereas a very rapid increase was observed when they are tested in unfamiliar cages. These results indicate that the relationship between T and offensive behaviour is not a simple one. The relevance of T for this behaviour depends upon the situation in which it occurs. Stimuli from a familiar environment (the territory in which the rat experienced many victories and other positive events) and probably also the defensive behaviour of the opponent apparently reduce the importance of signals from the internal environment (e.g. plasma testosterone level). In such a situation "experience" might become an important factor. The data of Christie and Barfield (1979b) support this view. Only in an unfamiliar cage, in the presence of an obtrusive opponent, does T appear to be an important determining factor for offensive behaviour.

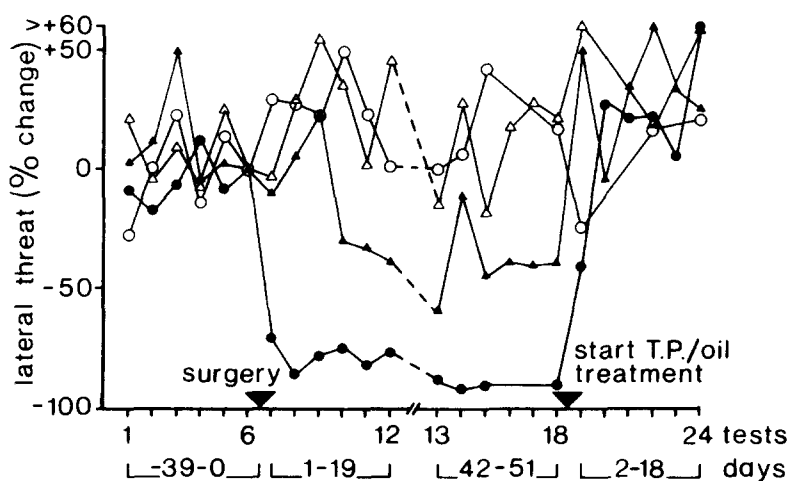

FIG. 5. Effect of castration and subsequent T.P. treatment on lateral threatening during tests in the home cage and (during tests) in an unfamiliar cage. Baselines are based on the last pre-operative tests. ● tests of castrated rats (9 animals) in unfamiliar cages; ▲ home cage tests of the same castrates; ○ test of sham-operated rats (6 animals) in unfamiliar cages; △ home cage tests of shams. 52 days after castration 6 out of 9 castrates received daily T.P. injections (0.75 mg) while the shams got daily oil injections.

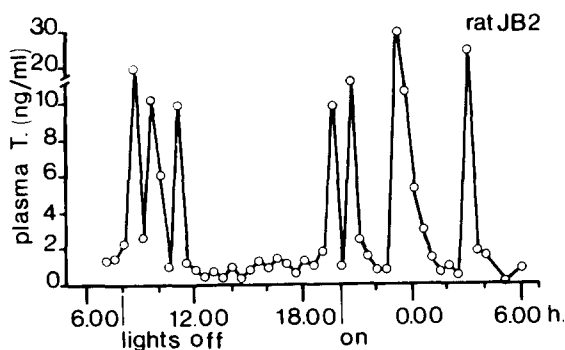

FIG. 6. Plasma T concentrations of a free moving unanaesthetized male rat over 24 hr. Every half hour a small blood sample (0.25 ml) was taken by means of a permanent jugular vein cannula, by which also transfusion blood was administered.

In order to specify the function of T in offensive behaviour in more detail, we measured plasma T concentration in a variety of experimental conditions.

The measurements were taken in free moving, unanaesthetized rats which were provided with a permanent jugular vein cannula. Blood samples could be taken frequently during long times without disturbing the animals (Steffens, 1969). Plasma T concentrations were measured by means of a radioimmunoassay.

Before discussing the results of these (yet unpublished) experiments, it is necessary to emphasize on some features of the endocrine system in question. A thorough knowledge of the properties of the pituitary-gonadal system is indispensable for these hormone-behaviour studies. One might expect that under resting conditions the plasma T concentration is rather stable, without large fluctuations. Theoretically, the feedback mechanism of the pituitary-gonadal axis (see Turner and Bagnara, 1976) can attend to this. However, the real picture is quite different. Bartke *et al.* (1973) showed that rats have an irregular pattern of T secretion. Low plasma T concentrations were alternated with very high concentrations. In our own experiments we also found such an irregular pattern. Adult male rats appeared to have a basal plasma T level (range 0–3 ng/ml), which alternated with peak concentrations. Figure 6 shows an example. A similar irregular pattern of plasma T secretion has also been found in some non-rodent species like bulls (Katongole *et al.*, 1971; Schaubacker, 1979) and rams (Katongole *et al.*, 1974; Purvis *et al.*, 1974). With respect to rats, there is still a controversy in the literature about the number of peaks as well as their temporal distribution (Wilson *et al.*, 1976; Kalra and Kalra, 1977; Mock *et al.*, 1978; Keating and Tcholakian, 1979).

Mock *et al.* (1978) performed the most extensive study on this subject. They demonstrated a trimodal rhythm of the plasma T concentration in 24 hr in the rat. This result seems rather conflicting with the data of Bartke (1973) and our data that do not demonstrate such a rhythm. One reason for this might be that in our experiment we collected at least one blood sample per hour per rat. In all other studies, including Mock's study, blood samples were taken less frequently. This means that short-lasting plasma T elevations could have been unnoticed in these latter studies. Although at the first sight the peak values of plasma T concentrations of our rats seemed to be distributed randomly, it appeared that there was a higher occurrence of peaks in the middle of the light period and in the beginning and the end of the dark part of 24 hr. The function of this pulsatile nature of the plasma T secretion is unknown. It is also unknown whether this hormonal rhythmicity is related to some behavioural rhythm. Since the performance of offensive behaviour in an unfamiliar area is fairly stable from test to test it seems that this behaviour is not subjected to the rapid natural changes of plasma T. For this the base-line T level seems to be the relevant factor (Schuurman, in preparation). However, environmental factors do influence baseline plasma T concentrations. Katongole *et al.* (1971) observed a rise of plasma T in bulls during the presentation of a teaser cow. Similar findings were observed in rats (Purvis and Haynes, 1974; Kamel and Frankel,

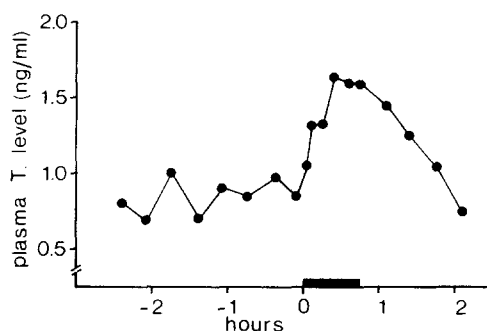

FIG. 7. Median plasma T concentration (10 experiments) of a male rat, in the presence of an oestrous female. Male and female were separated by wire netting. Males were provided with a permanent jugular vein canula for frequent blood sampling.

1978) and mice (Macrides *et al.*, 1975). We also demonstrated a short rise of plasma T in male rats during presentation of an estrous female rat (Fig. 7). A similar temporal elevation was also observed during agonistic encounters in male rats (in preparation).

So far it is clear that plasma T concentration is not very stable on an hourly basis, and the above features of the pituitary–gonadal axis must be taken into account when studying the interrelationships between this endocrine system and offensive behaviour.

In an extensive study we demonstrated that there are also long-lasting changes of the pituitary–gonadal axis resulting from interactions with conspecifics. We studied offensive behaviour in standard aggression tests with a subordinate opponent and measured plasma T concentrations (blood samples from permanent jugular vein canulas) before and after a serious agonistic encounter, both for victors and losers. It appeared that the defeated rats had a drastically lowered plasma T level some hours after the agonistic encounter with a dominant rat (Fig. 8). Most defeated rats maintained this lowered T level for at least 2 days, thereupon they regained pre-defeat levels. Some defeated rats still had lowered plasma T levels 8 or more days after defeat. Along with this decreased activity of the pituitary–gonadal system, there was a complete loss of clinch and other offensive behaviours and a high performance of defensive behaviour in the defeated rats during the standard tests in unfamiliar cages with an obtrusive, yet subordinate rat (Fig. 9). However, the same defeated rats still attacked intruders successfully in their home cages. Normal pre-defeat behaviour (much offensive behaviour and almost no defensive behaviour) during the tests in unfamiliar cages appeared again, along with the recovery from the low plasma T level. Victors of serious agonistic encounters showed neither a decrease of plasma T level nor changes in the performance of agonistic behaviour (Figs 8 and 9).

These results fit in very well with those of the castration experiments described above. For, following castration it was demonstrated that offensive behaviour in unfamiliar

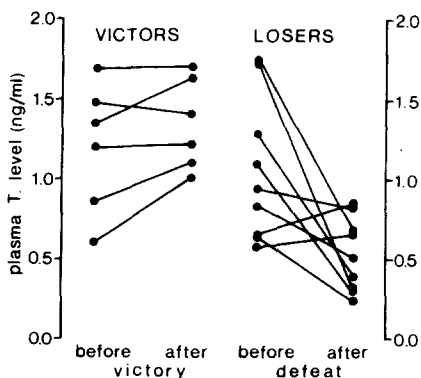

FIG. 8. Plasma T levels of victors and losers before and after an agonistic encounter. Each point represents the mean plasma T concentration of 20 blood samples per rat.

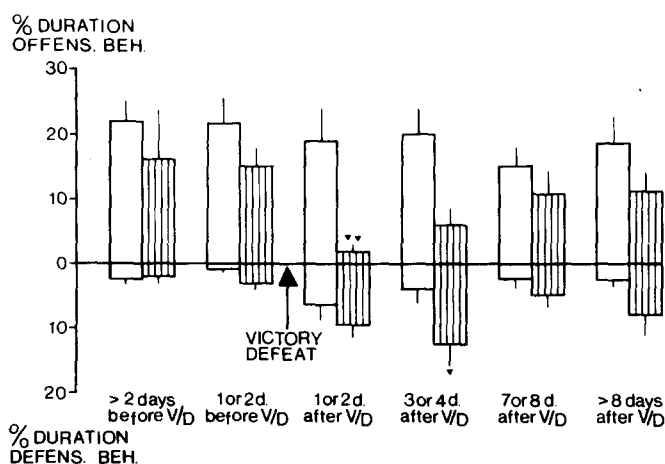

FIG. 9. Offensive and defensive behaviour of victors (\square , $n = 6$) and losers (\blacksquare , $n = 9$) of a serious agonistic encounter. Behaviour was measured daily over 15 min (standard) tests with a subordinate opponent in an unfamiliar cage. After two tests the experimental rats were confronted with a very aggressive male rat for 1 hr. Six out of 15 rats won the fights, whereas nine rats were defeated. On consecutive days the tests with subordinates were continued. Bars: s.e.m. ▼ significant increase of defensive behaviour compared to the last pre-defeat test; ▼ significant decrease of offensive behaviour compared to the last pre-defeat test.

cages disappeared, whereas offensive behaviour in the home cages was maintained. Also, in this second experiment a lowered plasma T level resulting from defeat was accompanied by a decrease of offensive behaviour in unfamiliar areas, but not in the home cage. These results strongly suggest that the pituitary-gonadal system plays an important role in the adaptation of offensive behaviour following agonistic experience. It will profit a defeated and temporal weakened male to avoid risky agonistic encounters outside the centre of its territory for a while till it has recovered from a physical or behavioural weakness. In the meanwhile this rat must continue defending his territory against intruders, because losing his territory might reduce his survival chances. A lowered gonadal hormone secretion after a serious defeat makes the rat behave less offensively outside the centre of his territory, whereas there is no such an effect on offence inside this centre. The absence of offensive behaviour and the performance of defensive behaviours reduces the probability of being attacked in the territory of an other rat. Maybe this probability is further reduced by an altered pheromone production also resulting from the lowered activity of the pituitary-gonadal system. In terms of the model of Fig. 3, the hormonal influence of T on the standard for territorial behaviour seems to be a reduction of the size of the "intact" territory.

4. Brain Structures and Offensive Behaviour

As we have seen, the mechanism for offensive behaviour can be considered as a regulatory mechanism with a few inputs, one output and a minimal number of functions in between. However, the reality we face in brain research is that there are many input variables that influence offensive behaviour: for instance, familiarity with the opponent, day-night rhythms, pheromones, cues for other behaviours, etc. Moreover, offensive behaviour is not a unitary output, it has many characteristics like frequencies, duration, repertoire, sequences, etc. In some way the brain is organized such that it processes all the incoming information in a way to produce the various behaviours at the right time and place. By manipulating the brain we may interfere anywhere within this process. The problem in brain research is firstly to find out which brain structures are involved in the behaviour mechanism and secondly how each structure contributes to the proper functioning of the mechanism as a whole. Of course, these two questions are closely related, because the simple fact that we can influence offensive behaviour with a certain brain manipulation does not tell us anything of how directly and how specifically that brain

structure is involved in this behaviour. This latter aspect asks for a detailed analysis of the relationship between input and output of the system both before and after a certain brain manipulation. In other words, we should know from a wide variety of input variables how they influence the various output characteristics of offensive behaviour. Essential for possible conclusions out of such an analysis is the assumption that each brain structure has its own specific function in the regulatory process leading from input to output. Such a principle seems likely, e.g., for the functioning of midbrain and brain-stem structures in motor control of cortical structures in sensory processing. It seems reasonable, therefore, to assume that the same principle holds for the functioning of limbic structures in complex behaviour.

In the following section we shall review some of the work on the central nervous organization of offensive behaviour in rats, and give some examples of our own work in which we tried to analyse the changes in the input-output relationship after the brain manipulation in more detail.

4.1. VENTROMEDIAL HYPOTHALAMUS (VMH)

A well known phenomenon of VMH lesioned rats is their tendency to overeat and the difficulty in handling these animals. This latter aspect brought a number of researchers to the idea that this area is not only involved in feeding behaviour but also in aggressive behaviour. When tested in a foot-shock situation, VMH lesioned animals indeed show a strong increase in reflexive fighting (Panksepp, 1971b; Adams, 1971; Eichelmann, 1971; Grossman, 1972; Colpaert and Wiepkema, 1976), suggesting that the VMH has an inhibitory role in defensive behaviour. Olivier (1978) came to the same conclusion by testing male rats with small anterior VMH lesions in a social situation. Such lesions did not affect the level of clinch, but reduced lateral threatening and specifically increased upright posture (Fig. 10), which is considered as a defensive behaviour element (Lehman and Adams, 1976). In fact, these animals only fight when being approached or investigated by the opponent.

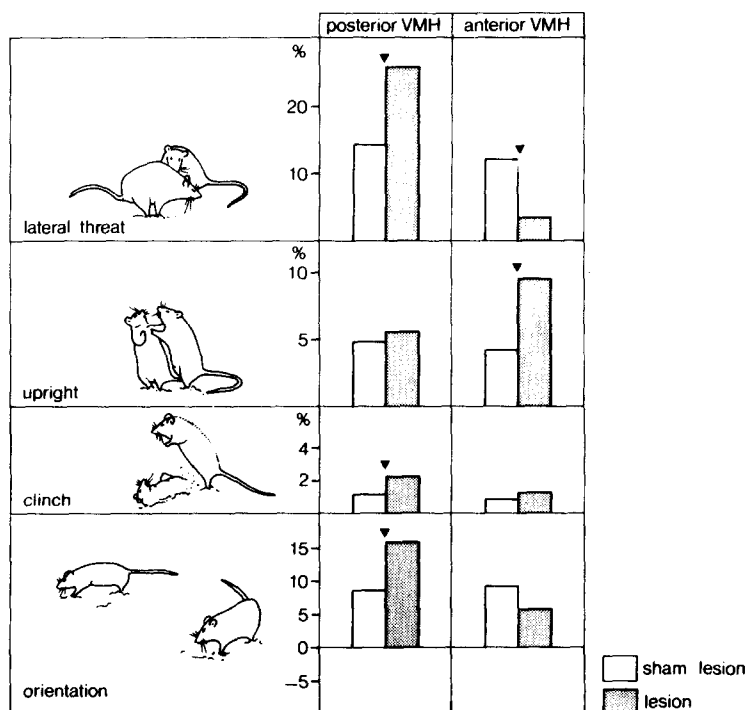

FIG. 10. Effects of electrolytic lesions in two different parts of the VMH on the relative time spent on some agonistic behaviours. ▼ indicates a significant difference ($p < 0.05$, Mann-Whitney U-test) between lesioned animals ($n = 12$) and sham-lesioned controls ($n = 10$).

Also, offensive behaviour can be affected by lesions in the VMH (Olivier, 1978). Lesions in the posterior part of the VMH caused a marked increase in lateral threatening, clinch and keeping down (Fig. 10). These animals actively take the initiative when confronted with a subordinate male intruder into their home cage. This functional subdivision of the VMH into a posterior part affecting offensive behaviour and an anterior part involved in defensive behaviour is also demonstrated by Albert and Wong (1978) using local anaesthesia of the VMH. Veening (1975) found a depression of social behaviour in a territorial situation during electrical stimulation of the VMH. Since also other types of behaviour were reduced, it is difficult to assess the specific significance of this result. Using large VMH lesions, Grossman (1972) found a loss of dominance in a food competition test. These data are difficult to relate, however, to the other findings because of the large lesions and the fact that Grossman used female rats in this experiment.

For the sake of convenience, we ascribed all the effects on agonistic behaviour to lesions of parts of the VMH. It is still possible, however, that damage to nearby located structures is responsible for the effect. Analysis of small hypothalamic lesions (v.d. Berg *et al.*, in preparation) suggests, e.g., that the increase in offensive behaviour is not the result of posterior VMH lesions, but is due to bilateral damage to one of the premamillary bodies.

Whatever the precise structure may be, it can be concluded that distinct areas of the medial hypothalamus have an inhibitory role in either offensive or defensive behaviour. In order to specify the role of the posterior VMH in offensive behaviour we have studied now a number of input variables how they affect offensive behaviour induced by a posterior VMH lesion.

4.1.1. Type of opponent

Olivier (1978) has tested posterior VMH lesioned animals in the presence of: (a) a subordinate male; (b) an estrous female; and (c) a dominant male. The behaviour of both control animals and posterior VMH lesioned animals in these three social situations is presented in Fig. 11. In the subordinate male situation we see the effect of the lesion on offensive behaviour as described above.

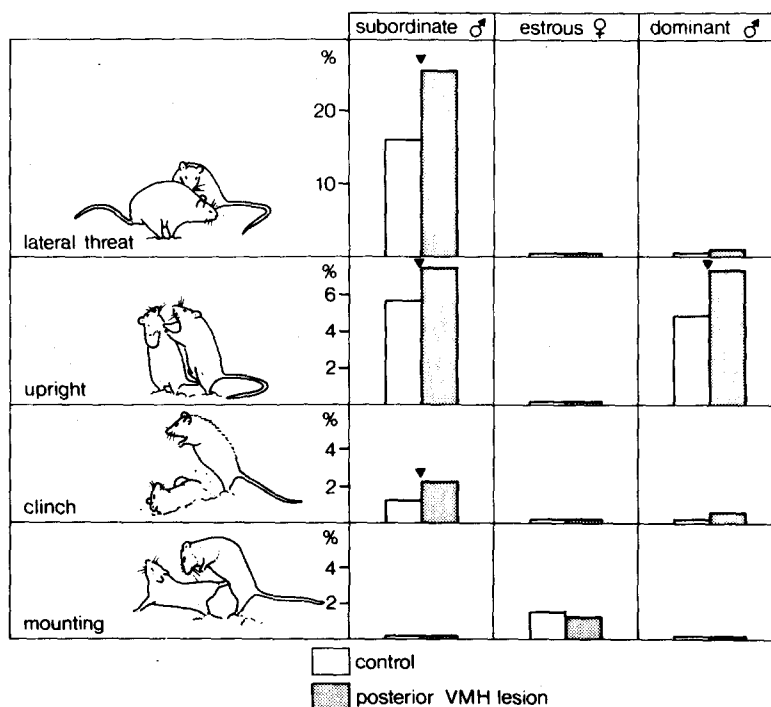

FIG. 11. Behaviour of posterior VMH lesioned animals and sham-lesioned controls in three different social situations. ▼ indicates a significant difference ($p < 0.05$, Mann-Whitney U-test) between lesioned animals ($n = 12$) and sham-lesioned controls ($n = 10$).

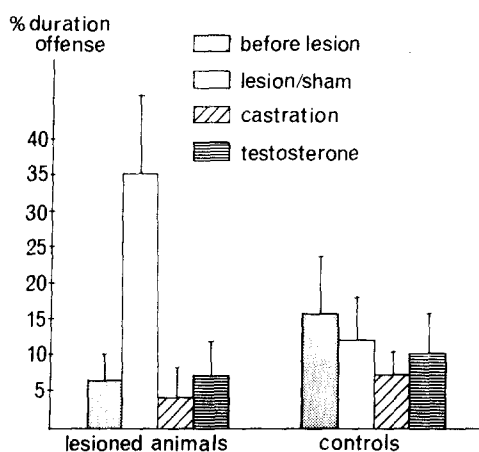

FIG. 12. Changes in offensive behaviour after castration and subsequent TP treatment in posterior VMH lesioned animals ($n = 6$) and sham-lesioned controls ($n = 5$).

In the presence of an estrous female, however, no offensive behaviour is performed; even sexual behaviour does not change after the lesion. In the dominant male situation only the relative time spent on upright posture is enhanced, lateral threatening does not change after the lesion. It can be concluded that a posterior VMH lesioned animal is well capable of adapting its offensive behaviour to the type of opponent that intrudes its territory. This adaptation is almost perfect in the presence of an oestrous female, whereas in the dominant male situation the lesioned animal is inclined to defend itself slightly more than a control animal. This latter phenomenon may not be typical for the lesion itself, but more generally characteristic for any highly aggressive animal. We may conclude, therefore, that the lesioned brain structure is not involved in a mechanism that allows for a male-female and a subordinate-dominant male recognition.

4.1.2. Testosterone

Similarly to changing the external situation, internal factors can be manipulated. One of these factors which is in particular relevant for offensive behaviour is testosterone. We have studied whether posterior VMH lesions affect the relationship between testosterone and offensive behaviour.

Figure 12 shows that highly offensive, posterior VMH lesioned rats strongly respond to castration; i.e. offensive behaviour drops to a level which is the same as that in a non-lesioned control after castration. This shows not only that the lesioned animal is still able to measure testosterone levels, but also that the offensive behaviour induced by the lesion is completely dependent on the presence of testosterone. A still unexplained phenomenon is the fact that offensive behaviour does not return to its high, precastration level after testosterone repletion despite normal plasma T concentrations.

4.2. LATERAL HYPOTHALAMUS (LH)

Considering the fact that the LH is a well-known area for manipulating a wide variety of behaviours, surprisingly little has been done on the role of the LH in intraspecific agonistic behaviour in the rat. Lesions in this area, interrupting most of the MFB, completely abolished territorial behaviour (Adams, 1971). Electrical stimulation of an area just ventral and lateral of the VMH can elicit intraspecific agonistic behaviour (Panksepp, 1971a; Woodworth, 1971; Koolhaas, 1978; Kruk *et al.*, 1979). Although Adams (1971) found no effect of LH lesions on shock-induced fighting there are some indications that also at the level of the LH a dissociation exists between offensive and defensive behaviour. During LH stimulation in the presence of a subordinate male, two types of responses can be distinguished; the most striking difference being the way in which the stimulation affects moving towards and moving away. Type I (Fig. 13) is

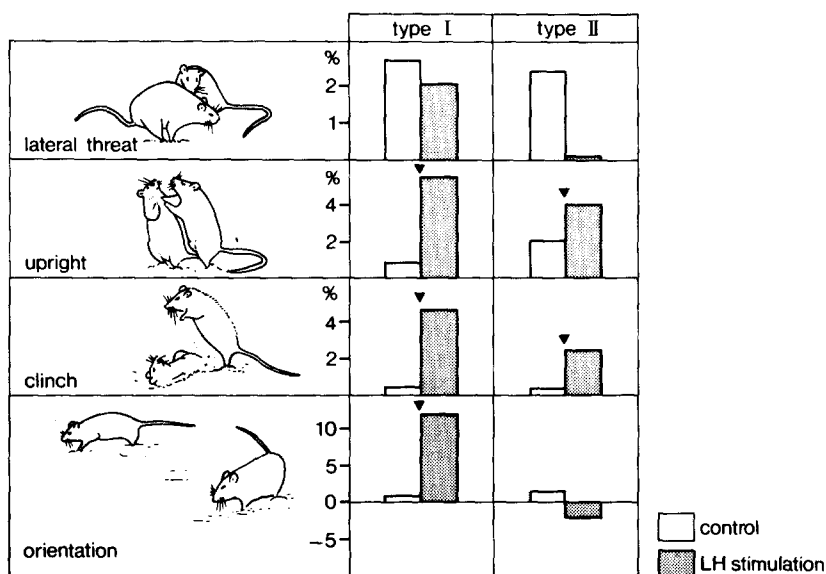

FIG. 13. Types of intraspecific agonistic behaviour elicited by electrical stimulation of the lateral hypothalamus (type I: $n = 13$; type II: $n = 10$). \blacktriangledown indicates a significant difference ($p < 0.05$, Wilcoxon Matched Pairs test) between the behaviour during and without electrical stimulation.

characterized by a strong orientation of the stimulated animal towards the opponent. This type strongly resembles offensive behaviour of a male rat in a territorial situation as has been described above. The same behavioural repertoire is performed with a similar patterning, while moreover these animals actively take the initiative in their social situation. This characteristic change in the orientation of the behaviour during stimulation is shown in Fig. 14a. Figure 14b shows that in the other type of response (type II) moving towards and moving away are equally affected; the stimulated animal just wanders about the cage, fighting only when it happens to meet the opponent. This incidental character is reflected in the occurrence of clinch, which reaches a constant level after a few seconds of stimulation. Because of this, and the fact that the agonistic behaviour consists almost exclusively of upright posture and clinch, this response may be similar to the defensive behaviour performed by a rat intruding into a well-established rat colony (Blanchard *et al.*, 1977) or during painful stimulation (Logan and Boice, 1969).

The histology of these electrode placements suggests a slight difference in the locations of the two types of responses. It can be concluded therefore, that different parts of the lateral hypothalamus have a facilitatory role in offensive and possibly also in defensive behaviour.

As for the studies on the posterior VMH we have investigated for a number of input variables how they affect offensive behaviour induced by electrical stimulation of the LH.

4.2.1. Type of opponent

The experimental animals were tested for offensive behaviour in the presence of: (a) a subordinate male; (b) an oestrous female; and (c) a dominant male. Figure 15 shows the behaviour in the three different social situations, both for non-stimulated controls and during LH stimulation. In the presence of a subordinate male, LH stimulation increases offensive behaviour as described above. In the presence of an oestrous female, investigation, genital grooming and mounting, which form the major part of the behaviour without stimulation, disappear almost entirely during stimulation. Instead, the stimulated animal sometimes attacks the oestrous female, but the level of this behaviour is strongly reduced when compared to the subordinate male situation.

The LH stimulated animal changes its behaviour in the presence of a dominant male in that it will never initiate a fight once it has been defeated by that opponent. However,

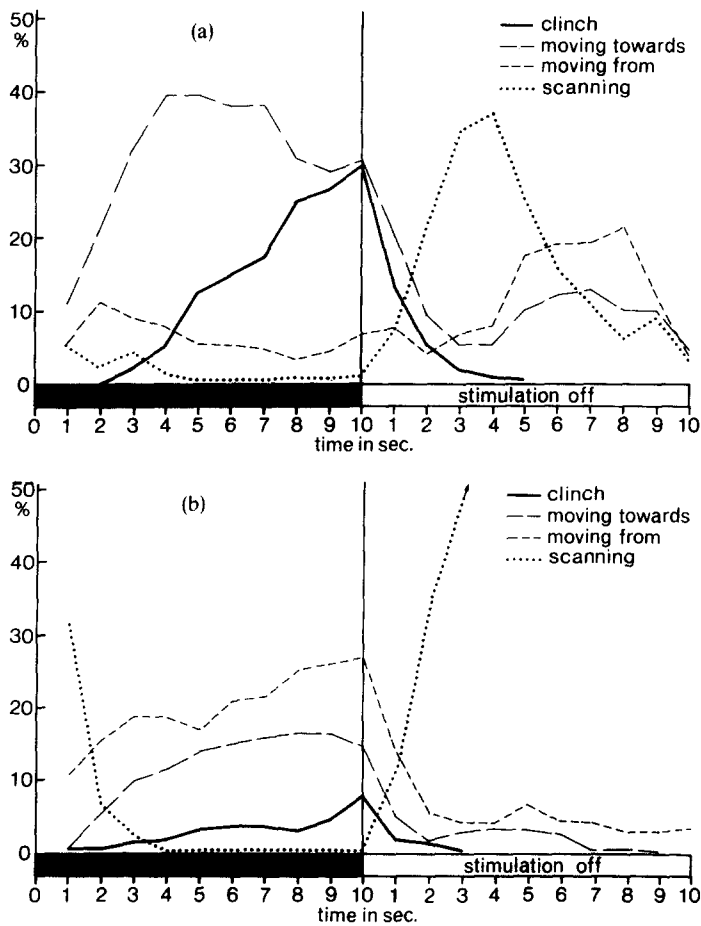

FIG. 14. Incidence of some behaviour patterns during electrical stimulation and a subsequent period without stimulation. (a) Typical example of a type I electrode (number of on-off periods: 55); (b) typical example of a type II electrode (number of on-off periods: 45).

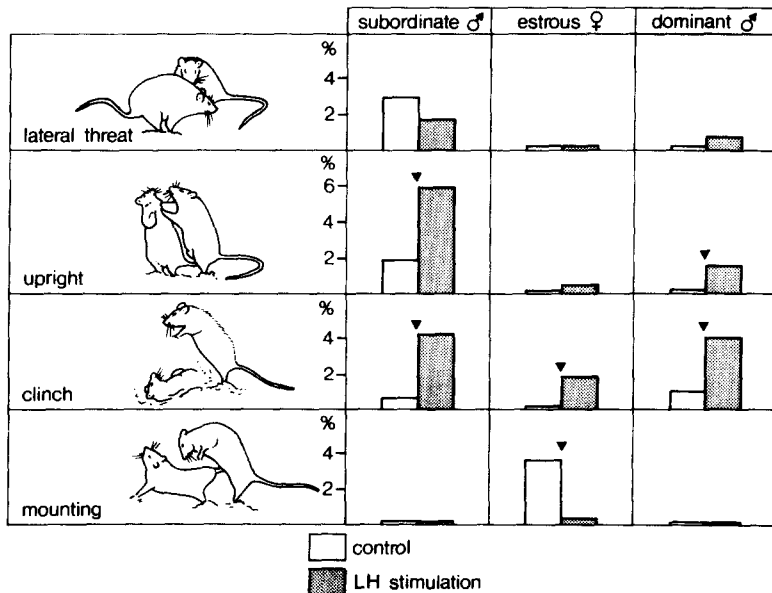

FIG. 15. Behaviour of experimental animals (type I) during LH stimulation and without stimulation in three different social situations. ▼ indicates a significant difference ($p < 0.05$ Wilcoxon Matched Pairs test) between tests with and without electrical stimulation.

there is still an increase in upright and clinch when compared to non-stimulated controls. This may be due to attacks of the dominant partner, which seems to be provoked by the restlessness of the stimulated animal.

It may be concluded that the animals are still able to adapt their behaviour to the type of opponent during LH stimulation. However, this adaptation is not entirely similar to what intact animals show. For example, we may wonder whether it is typical for LH stimulation that there is some fighting and a complete suppression of sexual behaviour in the oestrous female situation, or whether this holds for any highly aggressive motivated animal. Although we have no systematic data, our impression is that an intact male rat can readily switch from extreme aggression to sexual behaviour. This suggests that indeed something has been altered in the mechanism that allows for a male-female and a subordinate-dominant recognition during LH stimulation.

4.2.2. Testosterone

Figure 16 shows that LH-stimulation-induced offensive behaviour is still under the influence of testosterone—i.e. castration reduces the probability of occurrence of offensive behaviour whereas testosterone replacement reinstates the level of aggression elicited by the stimulation. It is important to notice that castrated animals are still able to perform stimulation induced offensive behaviour. With the same current intensity as used before castration, there seems to be still an enhanced level of offence after castration when compared to non-stimulated castrated controls.

It may be concluded that the regulation of offensive behaviour by testosterone is not short-circuited by the electrical LH stimulation. The dependency, however, is not as strong as in the case with VMH lesion induced offensive behaviour.

4.3. SEPTUM

The septal area has been frequently implicated in the control of agonistic behaviour. Large electrolytic lesions in this structure make the animals hyper-reactive and result in an increase in shock-elicited aggression (Brady and Nauta, 1955; Blanchard and Blanchard, 1968). This brought a number of researchers to test septal lesioned animals in a social situation. Generally, large septal lesions cause a decrease in attack behaviour in an open field situation or during food competition (Miczek and Grossman, 1972; Blanchard *et al.*, 1977; Lau and Miczek, 1977). Bunnell *et al.* (1966) report an increase in social rank in a food competition test. However, as the author says, this may not be due to a simple increase in aggressiveness. Other phenomena typical for this particular test situation might account for the result.

Most of the studies concern the effects of large septal lesions. A number of reports indicate, however, that a further subdivision of the septum can be made with respect to agonistic behaviour (Clody and Carlton, 1969; Poplawsky and Johnson, 1973). In an

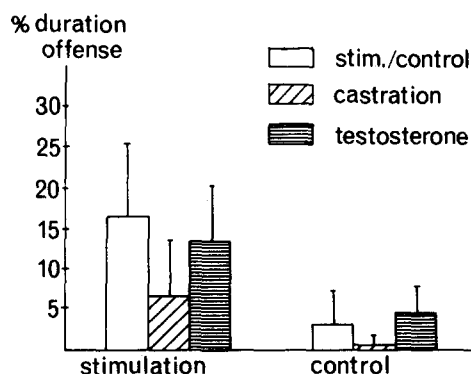

FIG. 16. Changes in offensive behaviour after castration and subsequent testosterone replacement both with and without electrical stimulation of the LH ($n = 7$).

open field situation in the presence of a conspecific, medial septal lesions result in a higher frequency of submissive behaviours and an increase in contact time. Lateral septal lesions caused hyper-emotionality and an increase in agonistic encounters. The exact nature of this agonistic behaviour is not clear, because some general aggression score is used. The increase in the emotionality rating which includes reactions to handling, vibrissae touching, etc. suggests, however, that the lateral septum is involved in defensive behaviour. Poplawsky (1975) showed that the ventral septal fibre tracts were critical in mediating the effects on social behaviour, suggesting that there is a functional connection between the septum and the hypothalamus.

An intriguing complication in the study of the role of the septum in agonistic behaviour is the finding that the effect of a lesion is transitory and seems to depend on the experience of the experimental animal (Ahmad and Harvey, 1968; Lau and Miczek, 1977). These variables have been insufficiently explored but they may be significant cues in the study of the function of the septum in agonistic behaviour.

5. Prefrontal Cortex

The prefrontal cortex of the rat can be subdivided anatomically into an orbital and a medial part (Leonard, 1969, 1972). This subdivision can also be demonstrated at the behavioural level. With respect to agonistic behaviour, lesions in the orbital frontal cortex caused a marked increase in a shock-induced aggression (Kolb, 1974; Kolb and Nonnema, 1974). Also, much aggression was observed when pairs of orbital frontal lesioned male rats were placed in a small cage unfamiliar to both animals. In this situation, especially submission, upright and biting were significantly enhanced. In a situation in which one of the orbital frontal lesioned animals is territory owner the results were rather equivocal. However, the fights that occurred were characterized by upright posture. These data suggest that the orbital frontal cortex is mainly involved in defensive behaviour.

Lesions of the medial portion of the prefrontal cortex did not result in changes in agonistic behaviour.

6. Amygdala

Very few studies deal with the role of amygdaloid nuclei in intraspecific agonistic behaviour in the rat.

Bunnell (1966) reports that lesions in the basolateral nuclei of male rats caused a significant decrease in the number of intermale interactions and the percentage of fights won. Busch and Barfield (1974), however, report a failure to alter territorial agonistic behaviour after large amygdaloid lesions.

Using a food competition test, Miczek *et al.* (1974) showed that small lesions in the periamygdaloid cortex, the cortical amygdaloid nucleus or the bed nucleus of the stria terminalis virtually eliminated agonistic behaviour. Small lesions in the lateral or central nuclei did not affect agonistic behaviour in this situation. The main problem with manipulations in the amygdala is its very complex structure and the elongation shape of the nuclei. Large lesions tend to destroy several nuclei at the same time, whereas small lesions restricted to one nucleus usually leave a considerable part of that nucleus intact. It is not surprising therefore that the results of lesion studies are somewhat contradictory.

In order to make more elongated lesions, restricted to only one nucleus, we placed two small electrolytic lesions behind each other (Wiepkema *et al.*, 1980). Figure 17 shows the relative changes from preoperative level of agonistic behaviour of three groups of male rats tested in their home cage in the presence of a subordinate male. Shamoperated controls show a marked increase of lateral threatening and upright posture in the course of testing. Apparently these animals become more experienced fighters in the course of testing. This is in contrast to animals with lesions in the basomedial nucleus of the

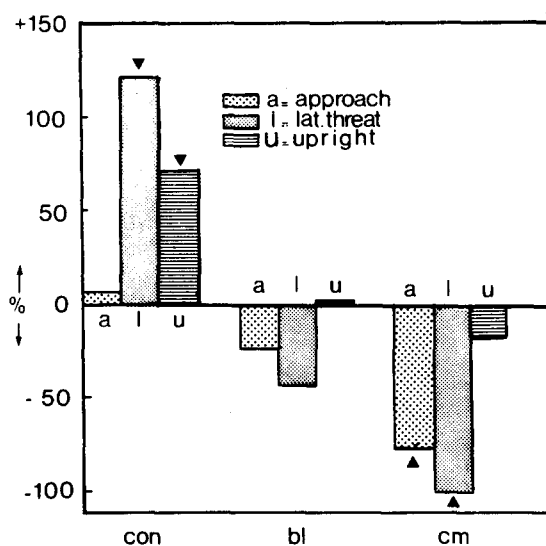

FIG. 17. Relative change from preoperative level (duration) of three behaviour elements after sham lesions (con) ($n = 14$), basolateral (bl) ($n = 13$), or corticomедial (cm) ($n = 13$) lesions of the amygdala. ∇ indicates a significant difference ($p < 0.05$ Wilcoxon Matched Pairs test) between pre- and postoperative level.

amygdala. These animals lost the ability to gain experience from previous encounters (see Fig. 17). Animals with corticomедial amygdaloid lesions even show a significant reduction in approach and lateral threatening when compared to preoperative control levels. Upright is not changed, suggesting that the lesion specifically affects offensive behaviour. Although the data are far from conclusive, it is tempting to consider the possibility that also in agonistic behaviour the amygdala is involved in the mediation of experiential factors.

7. Concluding Remarks

As we have seen, rats are socially living animals. It is not surprising, therefore, that their agonistic behaviour depends in a very subtle way on a wide variety of factors like type and behaviour of the opponent, place, context, individual recognition, etc.

In some way, the mechanism for this agonistic behaviour must be constructed such that it can cope with all these naturally occurring variables. Due to its complexity and a lack of studies on offensive behaviour, development of a detailed physiological model for this behaviour seems to be too ambitious an aim for the moment. An attempt to give a general outline of the neural circuitry involved in offensive behaviour is given by Adams (1979), using hierarchical models derived from ethology. In our combined ethological and physiological approach, we considered the mechanism for territorial behaviour as a regulatory system in which certain aspects of the external environment can be kept constant. In order to know the capacities of such a regulatory system, we must analyse in as detailed as possible a manner, the relationship between the input of the system and the behavioural output. An example of such an analysis is given for the relationship between testosterone and offensive behaviour. This hormone appears to be particularly relevant during offensive behaviour performed in an unfamiliar environment in the presence of an obtrusive opponent, suggesting that testosterone plays a role in establishing or expanding a territory. The hormone is less important in maintaining a territory. Here, experience with the environment might become the important factor.

Manipulation of the LH or the posterior VMH does not change the relationship between testosterone and offensive behaviour significantly, suggesting that these two brain structures are not strongly involved in the neural circuitry that affects agonistic behaviour on the basis of information about the plasma testosterone level. Since there

seems to be a close interaction between testosterone and experiential factors, and the fact that posterior VMH lesion evoked aggression is completely dependent on testosterone, it is tempting to consider the possibility that this neural structure is involved in the mediation of these experiential factors. We also obtained some indications that the amygdala might be important for this as well.

A similar analysis of changes in input-output relationship caused by brain manipulations was made for variation in the type of opponent presented to the experimental animal. This analysis led to the conclusion that neither the LH, nor the posterior VMH, plays an important role in the mediation of information about the type of opponent. Although we in fact measure the behavioural capacities of the intact parts of the brain, this kind of analysis may ultimately lead towards conclusions about a possible functioning of the manipulated brain structure in the behavioural mechanism.

One has to be careful with such conclusions, because they are based on qualitative data only. On a quantitative basis, conclusions are much more difficult to draw, due to a lack of good quantitative models, with similar levels of agonistic behaviour as the experimental animals.

In fact, our model is a very simple scheme of the software necessary for the realization of agonistic behaviour. Much more theorizing and experimenting is necessary before we can relate the various pieces of software into the physiological hardware. We can even only speculate about the relationship between software and hardware. A major problem in this respect is the question of how the various hypothetical regulatory functions in the software are represented physiologically: by neurons, groups of neurons, circuitries, or hormones? In any case, our present model needs to be modified and extended much before it can account for complex functions such as recognition of the type of opponent, selection of behaviour strategies, sequencing of behavioural elements, interaction between environmental factors, experience and testosterone, etc.

We do realize that we have made only a minor step towards an understanding of the organization of offensive behaviour. However, we hope to have shown that our approach of testing animals in biologically meaningful conditions, using ethological observation techniques, may ultimately lead towards a better understanding of the physiological mechanism of intraspecific agonistic behaviour.

References

- ADAMS D. B. (1971) Defense and territorial behaviour dissociated by hypothalamic lesions in the rat. *Nature*, **232**, 573-574.
- ADAMS, D. B. (1979) Brain mechanisms for offense, defense, and submission. *The Behavioral and Brain Sciences*, **2**, 201-241.
- AHMAD, S. S. and HARVEY, S. S. (1968) Long-term effects of septal lesions and social experience on shock-elicited fighting in rats. *J. comp. physiol. Psychol.* **66**, 596-602.
- ARCHER, J. (1976) The organisation of aggression and fear in vertebrates. In: *Perspectives in Ethology*, Vol. 2, pp. 231-298. (Eds. P. D. G. BATESON and N. KLOPFER.) Plenum Press, New York.
- ALBERT, D. J. and WONG, R. C. K. (1978) Inter-animal aggression and hyperreactivity following hypothalamic infusion of local anesthetic in the rat. *Physiol. Behav.* **20**, 755-761.
- BAERENDS, G. P. (1976) The functional organization of behaviour. *Anim. Behav.* **24**, 726-738.
- BARFIELD, R. J., BUSCH, D. E. and WALLEN, K. (1972) Gonadal influence on agonistic behavior in the male domestic rat. *Horm. Behav.* **3**, 247-259.
- BARKLEY, M. S. and GOLDMAN, B. D. (1977) A quantitative study of serum testosterone, sex accessory organ growth, and the development of intermale aggression in the mouse. *Horm. Behav.* **8**, 208-218.
- BARNETT, S. A. (1963) *The Rat, a Study in Behavior*. Univ. of Chicago Press, Chicago, London.
- BARTKE, A., STEELE, R. E., MUSTO, N. and CALDWELL, B. V. (1973) Fluctuations in plasma testosterone levels in adult male rats and mice. *Endocrinol.* **92**, 1223-1228.
- BEAN, N. J. and CONNER, R. (1978) Central hormonal replacement and homeage dominance in castrated rats. *Horm. Behav.* **11**, 100-109.
- BEEMAN, E. A. (1947) The effect of male hormone on aggressive behavior in mice. *Physiol. Zool.* **20**, 373-405.
- BERMOND, B. (1978) Neuro-hormonal regulation of aggressive and sexual behavior in the rat. Thesis, Amsterdam.
- BEVAN, W., LEVY, G. W., WHITEHOUSE, J. M. and BEVAN, J. M. (1957) Spontaneous aggressiveness in two strains of mice castrated and treated with one of three androgens. *Physiol. Zool.* **30**, 341-349.
- BLANCHARD, R. J. and BLANCHARD, D. C. (1968) Limbic lesions and reflexive fighting. *J. comp. physiol. Psychol.* **66**, 603-605.

- BLANCHARD, R. J. and BLANCHARD, D. C. (1977) Aggressive behaviour in the rat. *Behav. Biol.* **21**, 197-224.
- BLANCHARD, R. J., BLANCHARD, D. C. and TAKAHASHI, L. K. (1977) Reflexive fighting in the albino rat: aggressive or defensive behaviour? *Aggressive Behavior*, **3**, 145-155.
- BLANCHARD, D. C., BLANCHARD, R. J., TAKAHASHI, L. K. and TAKAHASHI, T. (1977) Septal lesion and aggressive behaviour. *Behav. Biol.* **21**, 157-161.
- BLANCHARD, R. J., FUKANAGA, K., BLANCHARD, D. C. and KELLY, M. J. (1975) Conspecific aggression in the laboratory rat. *J. comp. physiol. Psychol.* **89**, 1204-1209.
- BOWDEN, N. J. and BRAIN, P. F. (1978) Blockade of testosterone-maintained intermale fighting in albino laboratory mice by an aromatization inhibitor. *Physiol. Behav.* **20**, 543-546.
- BRADY, J. V. and NAUTA, W. J. H. (1953) Subcortical mechanisms in emotional behavior: affective changes following septal forebrain lesions in the albino rat. *J. comp. physiol. Psychol.* **46**, 339-346.
- BRONSTEIN, P. M. and HIRSCH, S. M. (1976) Ontogeny of defensive reactions in Norway rats. *J. comp. physiol. Psychol.* **90**, 620-629.
- BUNNEL, B. N. (1966) Amygdaloid lesions and social dominance in the hooded rat. *Psychon. Sci.* **6**, 93-94.
- BUNNEL, B. N., SEMPORAD, J. P. and FLESHER, C. K. (1966) Septal forebrain lesions and social dominance behaviour in the hooded rat. *Psychon. Sci.* **6**, 207-208.
- BUSCH, D. E. and BARFIELD, R. J. (1974) A failure of amygdaloid lesions to alter agonistic behavior in the laboratory rat. *Physiol. Behav.* **12**, 887-892.
- CALHOUN, J. B. (1962) *The Ecology and Sociology of the Norway Rat*. United States Dept. of Health, Education and Welfare, Bethesda, Md.
- CHRISTIE, M. H. and BARFIELD, R. J. (1979a) Effects of aromatizable androgens on aggressive behaviour among rats (*Rattus norvegicus*). *J. Endocr.* **83**, 17-26.
- CHRISTIE, M. H. and BARFIELD, R. J. (1979b) Effects of castration and home cage residency on aggressive behavior in rats. *Horm. Behav.* **13**, 85-91.
- CLODY, D. E. and CARLTON, P. L. (1969) Behavioral effects of lesions of the medial septum of rats. *J. comp. physiol. Psychol.* **67**, 344-351.
- COLPAERT, F. C. and WIEPKEMA, P. R. (1976) Effects of Ventromedial hypothalamus lesions on spontaneous intraspecies aggression in male rats. *Behav. Biol.* **16**, 117-125.
- EICHELMAN, B. (1971) Effect of subcortical lesions on shock-induced aggression in the rat. *J. comp. physiol. Psychol.* **74**, 331-339.
- GHANADIAN, R., LEWIS, J. G. and CHISOLM, G. D. (1975) Serum testosterone and dihydrotestosterone changes with age in the rat. *Steroids*, **25**, 753-762.
- GORDON, T. P., BERNSTEIN, J. S. and ROSE, R. M. (1978) Social and seasonal influences on testosterone secretion in the male rhesus monkey. *Physiol. Behav.* **21**, 623-627.
- GRANT, E. C. and MACKINTOSH, J. H. (1963) A comparison of the social postures of some common laboratory rodents. *Behav.* **21**, 246-259.
- GREENSTEIN, B. D. (1979) Androgen receptors in the rat brain, anterior pituitary gland and ventral prostate gland: effect of orchidectomy and aging. *J. Endocr.* **81**, 75-81.
- GROSSMAN, S. P. (1972) Aggression, avoidance, and reaction to novel environments in female rats with ventromedial hypothalamic lesions. *J. comp. physiol. Psychol.* **78**, 274-283.
- GROTA, L. J. (1971) Effects of age and experience on plasma testosterone. *Neuroendocrinol.* **8**, 136-143.
- KALRA, P. S. and KALRA, S. P. (1977) Circadian periodicities of serum androgens, progesterone, gonadotropins and luteinizing-releasing hormone in male rats: the effects of hypothalamic differentiation, castration and adrenalectomy. *Endocrinol.* **101**, 1821-1827.
- KAMEL, F. and FRANKEL, A. I. (1978) Hormone release during mating in the male rat: time course, relation to sexual behavior, and interaction with handling procedures. *Endocrinol.* **103**, 2172-2181.
- KATONGOLE, C. B., NAFTOLIN, F. and SHORT, R. V. (1971) Relationship between blood levels of luteinizing hormone and testosterone in bulls, and the effects of sexual stimulation. *J. Endocr.* **50**, 457-466.
- KATONGOLE, C. B., NAFTOLIN, F. and SHORT, R. V. (1974) Seasonal variations in blood luteinizing hormone and testosterone levels in rams. *J. Endocr.* **60**, 101-106.
- KEATING, J. and TCHOLAKIAN, R. K. (1979) *In vivo* patterns of circulating steroids in adult male rats. I. Variations in testosterone during 24- and 48-hour standard and reverse light/dark cycles. *Endocrinol.* **104**, 184-189.
- KINSON, G. A. and LIU, C-C. (1973) Further evidence of inherent testicular rhythms in the laboratory rat. *J. Endocr.* **56**, 337-338.
- KOLB, B. (1974) Social behavior of rats with chronic prefrontal lesions. *J. comp. physiol. Psychol.* **87**, 466-474.
- KOLB, B. and NONNEMAN, A. J. (1974) Frontolimbic lesions and social behavior in the rat. *Psychol. Behav.* **13**, 637-643.
- KOOLHAAS, J. M. (1978) Hypothalamically induced intraspecific aggressive behaviour in the rat. *Exp. Brain Res.* **32**, 365-375.
- KRUK, M. R., POEL, A. M. VAN DER and VOS-FRERICHS, T. P. DE (1979) The induction of aggressive behaviour by electrical stimulation in the hypothalamus of male rats. *Behav.* **70**, 292-322.
- LAU, P. and MICZEK, K. A. (1977) Differential effects of septal lesions on attack and defensive-submissive reactions during intraspecies aggression in rat. *Physiol. Behav.* **18**, 479-486.
- LEHMAN, M. N. and ADAMS, D. B. (1977) A statistical and motivational analysis of the social behaviors of the male laboratory rat. *Behav.* **61**, 238-275.
- LEONARD, C. M. (1969) The prefrontal cortex of the rat. *Brain Res.* **12**, 321-343.
- LEONARD, C. M. (1972) The connections of the dorsomedial nuclei. *Brain Behav. Evol.* **6**, 524-541.
- LESHNER, A. I. and MOYER, J. A. (1975) Androgens and agonistic behavior in mice: relevance to aggression and irrelevance to avoidance of attack. *Physiol. Behav.* **15**, 695-699.
- LOGAN, F. A. and BOICE, R. (1969) Aggressive behaviors of paired rodents in an avoidance context. *Behav.* **34**, 161-183.
- LORE, R. L. and FLANELLY, K. (1977) Rat societies. *Scient. Amer.* **236**, 106-116.

- LUCIANO, D. and LORE, R. (1975) Aggression and social experience in domesticated rats. *J. comp. physiol. Psychol.* **88**, 917-923.
- LUTTGE, W. G. and HALL, N. R. (1973) Androgen-induced agonistic behavior in castrate male Swiss-Webster mice: comparison of four naturally occurring androgens. *Behav. Biol.* **8**, 725-732.
- MACRIDES, F., BARTKE, A. and DALTERIO, S. (1975) Strange females increase plasma testosterone levels in male mice. *Science*, **189**, 1104-1106.
- McKINNEY, T. D. and DESJARDINS, C. (1973) Postnatal development of the testis, fighting behavior, and fertility in house mice. *Biol. Reprod.* **9**, 279-294.
- MICZEK, K. A. and GROSSMAN, S. P. (1972) Effects of septal lesions on inter- and intraspecific aggression in rats. *J. comp. physiol. Psychol.* **79**, 37-45.
- MICZEK, K. A., BRYKCYNSKI, T. and GROSSMAN, S. P. (1974) Differential effects of lesions in amygdala, periamygdaloid cortex or stria terminalis on aggressive behavior in rats. *J. comp. physiol. Psychol.* **87**, 760-771.
- MOCK, E. J., KAMEL, F., WRIGHT, W. W. and FRANKEL, A. I. (1975) Seasonal rhythm in plasma testosterone and luteinising hormone of the male laboratory rat. *Nature*, **256**, 61-63.
- MOCK, E. J., NORTON, H. W. and FRANKEL, A. I. (1978) Daily rhythmicity of serum testosterone concentration in the male laboratory rat. *Endocrinol.* **103**, 1111-1121.
- MORGAN, B. J. T., SIMPSON, M. J. A., HANBY, J. P. and HALL-CRAGGS, J. (1976) Visualizing interaction and sequential data in animal behavior. Theory and application of cluster-analysis methods. *Behav.* **56**, 1-43.
- MOGER, W. H. (1977) Serum 5α -androstane- 3α , 17β -diol, androsterone, and testosterone concentrations in the male rat. Influence of age and gonadotropin stimulation. *Endocrinol.* **100**, 1027-1032.
- NAES, O. and ATTRAMADAL, A. (1974) Uptake and binding of androgens by the anterior pituitary gland, hypothalamus, preoptic area and brain cortex of rats. *Acta Endocrinol.* **76**, 417-430.
- OLIVIER, B. (1977) The ventromedial hypothalamus and aggressive behavior in rats. *Aggr. Behav.* **3**, 47-56.
- OWEN, K., PETERS, P. J. and BRONSON, F. H. (1973) Differential responsiveness to replacement therapy of pre- and post-pubertally castrated mice with respect to intermale aggression. *Horm. Behav.* **4**, 301-306.
- OWEN, K., PETERS, P. J. and BRONSON, F. H. (1974) Effects of intracranial implantation of testosterone propionate on intermale aggression in the castrated male mouse. *Horm. Behav.* **5**, 83-92.
- PANKSEPP, J. (1971a) Aggression elicited by electrical stimulation of hypothalamus in albino rats. *Physiol. Behav.* **6**, 321-329.
- PANKSEPP, J. (1971b) Effect of hypothalamic lesions on mouse-killing and shock-induced fighting in rats. *Physiol. Behav.* **6**, 311-316.
- PEYS, G. L. A. M. (1977) Development of social behaviour in the rat. Thesis, Nijmegen.
- POPLAWSKY, A. (1975) Effects of septal-fiberknife cuts on rat open-field social behavior. *Physiol. Behav.* **15**, 177-184.
- POPLAWSKY, A. and JOHNSON, D. A. (1973) Open-field social behavior of rats following lateral or medial septal lesions. *Physiol. Behav.* **11**, 845-854.
- PRICE, E. O. and BELANGER, P. L. (1977) Maternal behavior of wild and domestic stocks of Norway rats. *Behav. Biol.* **20**, 60-69.
- PURVIS, K. and HAYNES, N. B. (1974) Short-term effects of copulation, human chorionic gonadotrophin injection and non-tactile association with a female on testosterone levels in the male rat. *J. Endocr.* **60**, 429-439.
- PURVIS, K., ILLIUS, A. W. and HAYNES, N. B. (1974) Plasma testosterone concentrations in the ram. *J. Endocr.* **61**, 241-253.
- RESKO, J. A., FEDER, H. H. and GOY, R. W. (1968) Androgen concentrations in plasma and testis of developing rats. *J. Endocr.* **40**, 485-491.
- SAR, M. and STUMPF, W. E. (1972) Autoradiographic localisation of radioactivity in the rat brain after the injection of $1,2\text{-}^3\text{H}$ -testosterone. *Endocrinol.* **92**, 251-256.
- SCHAUBACKER, B. D. (1979) Testosterone secretion in cryptorchid and intact bulls injected with gonadotrophin-releasing hormone and luteinizing hormone. *Endocrinol.* **104**, 360-364.
- SHERIDAN, P. J. (1978) Localization of androgen and estrogen-concentrating neurons in the diencephalon and telencephalon of the mouse. *Endocrin.* **103**, 1328-1334.
- STEFFENS, A. B. (1969) A method for frequent sampling of blood and continuous infusion of fluids in the rat without disturbing the animal. *Physiol. Behav.* **4**, 833-836.
- STERN, J. M. and EISENFELD, A. J. (1971) Distribution and metabolism of ^3H -testosterone in castrated male rats; Effects of cyproterone, progesterone and unlabeled testosterone. *Endocrinol.* **88**, 1117-1125.
- TELLE, H. J. (1966) Beitrag zur Kenntnis der Verhaltensweise von Ratten vergleichend dargestellt bei *Rattus norvegicus* und *Rattus rattus*. *Z. angew. Zool.* **53**, 126-196.
- TIMMERMANS, P. J. A. (1978) Social behaviour in the rat. Thesis, Nijmegen.
- TOATES, F. M. (1979) Homeostasis and drinking. *Behav. Brain Sci.* **2**, 95-139.
- TOATES, F. M. and ARCHER, J. (1978) A comparative review of motivational systems using classical control theory. *Anim. Behav.* **26**, 368-380.
- TURNER, L. D. and BAGNARA, J. T. (1976) *General Endocrinology*. Saunders, Philadelphia.
- VEENING, J. G. (1975) Behavioral changes induced by electrical stimulation of ventromedial hypothalamic area of rats. *Brain Res.* **85**, 91.
- WIEPKEMA, P. R. (1978) Reactions on crowding. *Proc. of the Zodiac Symposium on Adaptation*, pp. 25-29. Wageningen, The Netherlands.
- WIEPKEMA, P. R., KOOLHAAS, J. M. and OLIVIER-AARDEMA, R. (1980) Adaptive aspects of neuronal elements in agonistic behavior. In: *Progress in Brain Research*, Vol. 53. *Adaptive Capabilities of the Nervous System*. Eds P. S. McCONNEL, G. J. BOER, H. J. ROMIJN, N. E. v. D. POLL and M. A. CORNER, in press.
- WILSON, M. J., McMILLIN, J. M., SEAL, U. S. and AHMED, K. (1976) Circadian variations of serum testosterone in the adult male rat with a late morning acrophase. *Experientia*, **32**, 944-945.
- WOODWORTH, C. H. (1971) Attack elicited in rat by electrical stimulation of the lateral hypothalamus. *Physiol. Behav.* **6**, 345-353.