

University of Groningen

## The mobility of Na<sup>+</sup>, Li<sup>+</sup>, and K<sup>+</sup> ions in thermally grown SiO<sub>2</sub> films

Greeuw, G.; Verwey, J. F.

*Published in:*  
Journal of Applied Physics

*DOI:*  
[10.1063/1.334256](https://doi.org/10.1063/1.334256)

**IMPORTANT NOTE:** You are advised to consult the publisher's version (publisher's PDF) if you wish to cite from it. Please check the document version below.

*Document Version*  
Publisher's PDF, also known as Version of record

*Publication date:*  
1984

[Link to publication in University of Groningen/UMCG research database](#)

*Citation for published version (APA):*  
Greeuw, G., & Verwey, J. F. (1984). The mobility of Na<sup>+</sup>, Li<sup>+</sup>, and K<sup>+</sup> ions in thermally grown SiO<sub>2</sub> films. *Journal of Applied Physics*, 56(8), 2218-2224. <https://doi.org/10.1063/1.334256>

### Copyright

Other than for strictly personal use, it is not permitted to download or to forward/distribute the text or part of it without the consent of the author(s) and/or copyright holder(s), unless the work is under an open content license (like Creative Commons).

### Take-down policy

If you believe that this document breaches copyright please contact us providing details, and we will remove access to the work immediately and investigate your claim.

*Downloaded from the University of Groningen/UMCG research database (Pure): <http://www.rug.nl/research/portal>. For technical reasons the number of authors shown on this cover page is limited to 10 maximum.*

# The mobility of Na<sup>+</sup>, Li<sup>+</sup>, and K<sup>+</sup> ions in thermally grown SiO<sub>2</sub> films

G. Greeuw, and J. F. Verwey

Citation: *Journal of Applied Physics* **56**, 2218 (1984); doi: 10.1063/1.334256

View online: <https://doi.org/10.1063/1.334256>

View Table of Contents: <http://aip.scitation.org/toc/jap/56/8>

Published by the [American Institute of Physics](#)

---

## Articles you may be interested in

[Drift mobilities of Na<sup>+</sup> and K<sup>+</sup> ions in SiO<sub>2</sub> films](#)

*Applied Physics Letters* **31**, 532 (1977); 10.1063/1.89766

[Ion Transport Phenomena in Insulating Films](#)

*Journal of Applied Physics* **36**, 1664 (1965); 10.1063/1.1703105

[Mobile ions in SiO<sub>2</sub>: Potassium](#)

*Journal of Applied Physics* **48**, 1127 (1977); 10.1063/1.323790

[On the mobility of potassium ions in SiO<sub>2</sub>](#)

*Journal of Applied Physics* **50**, 4834 (1979); 10.1063/1.326547

[Phosphorus out-diffusion during high temperature anneal of phosphorus-doped polycrystalline silicon and SiO<sub>2</sub>](#)

*Journal of Applied Physics* **56**, 2225 (1984); 10.1063/1.334281

[Ion transport phenomena in oxide layer on the silicon surface and electron–ion exchange effects at the SiO<sub>2</sub>/Si interface](#)

*Journal of Applied Physics* **89**, 130 (2001); 10.1063/1.1327610

---

**AIP** | Journal of Applied Physics SPECIAL TOPICS



# The mobility of Na<sup>+</sup>, Li<sup>+</sup>, and K<sup>+</sup> ions in thermally grown SiO<sub>2</sub> films

G. Greeuw and J. F. Verwey  
State University, Groningen, The Netherlands

(Received 28 December 1983; accepted for publication 14 March 1984)

Na<sup>+</sup>, Li<sup>+</sup>, and K<sup>+</sup> ions have been implanted in thermally grown oxides ( $T_{\text{ox}} = 1000^\circ\text{C}$ ) of metal-oxide-silicon structures. The mobilities of the Na<sup>+</sup> and Li<sup>+</sup> ions have been determined by means of the isothermal transient ionic current method in the temperature range 100–300 °C. The K<sup>+</sup> mobility has been obtained by means of triangular voltage sweep measurements in the range 350–450 °C. The results show that the Na<sup>+</sup> and the Li<sup>+</sup> mobilities are not significantly different. The activation energies of the three measured mobilities are shown to agree with a quantitative model which has been developed by Anderson and Stuart [J. Am. Ceram. Soc. 37, 573 (1954)].

## I. INTRODUCTION

In the last two decades an extensive study has been performed on the electrical instability in metal-oxide-silicon structures (MOS), caused by mobile alkali ions in the oxide. However, only a few papers have reported about the mobility of these alkali ions, of which sodium is by far the most important because sodium contamination is hard to avoid. Nevertheless, the other mobile ions, i.e., Li<sup>+</sup> and K<sup>+</sup>, are interesting, since the difference in ion size can give information about the conduction process that takes place in the oxide layer. The results of various workers on Na<sup>+</sup>,<sup>1</sup> K<sup>+</sup>,<sup>1,2</sup> Li<sup>+</sup>, Rb<sup>+</sup>,<sup>3</sup> and Cs<sup>+</sup> (Ref. 4) ions in thermally grown SiO<sub>2</sub> layers indicate that somewhere between the ion radii of potassium (1.33 Å) and rubidium (1.48 Å) a limit is reached, above which ion drift in the oxide is impossible. It is well established that Na<sup>+</sup> ions are more mobile than K<sup>+</sup> ions<sup>1</sup> and therefore it is sometimes assumed<sup>5</sup> that Li<sup>+</sup> ions are more mobile than Na<sup>+</sup> ions because of the smaller ion radius. However, experimental evidence for this assumption is not available. Our results prove that the mobility difference for Na<sup>+</sup> and Li<sup>+</sup> ions is not significant in the case of oxide layers grown at 1000 °C.

Moreover, we have determined the activation energy  $E_a$  of the mobility in the case of Na<sup>+</sup>, Li<sup>+</sup>, and K<sup>+</sup> ions. We show that the dependence of  $E_a$  on the ion radius  $r$  can be described in a satisfactory manner by means of a model, developed by Anderson and Stuart.<sup>6</sup>

## II. SAMPLE PREPARATION

All measurements have been performed on MOS capacitors, made on (100)-oriented, *n*-type silicon wafers. The oxide layers were thermally grown in a dry or wet O<sub>2</sub> ambient at 1000 °C. Before the oxidation the furnace tube was cleaned with a 2% C<sub>2</sub>H<sub>3</sub>Cl<sub>3</sub>/O<sub>2</sub> mixture at 1100 °C to remove sodium from the system. The thickness of the oxide film varied from 1000 to 10 400 Å.

Most of the samples have been implanted with one of the three mobile ion species: Na<sup>+</sup>, Li<sup>+</sup>, and K<sup>+</sup>. The implanted dose ranged from  $3 \times 10^{11}$  to  $3 \times 10^{13}$  ions/cm<sup>2</sup>. The energy of the implanted ions was 25 keV in the case of Na<sup>+</sup> and K<sup>+</sup> and 15 keV in the case of Li<sup>+</sup>. The projected range  $R_p$  of the implanted ions is given in Table I.

We used the ion implantation technique for the alkali doping in order to have a precise control on the type and amount of the alkali ions in the oxide. For instance, with a chemical preparation of Li<sup>+</sup> samples, it is very difficult to avoid sodium contamination. For part of the samples the background sodium concentration was used to measure the Na<sup>+</sup> mobility.

The electrodes of the MOS structure were obtained by evaporation of 1-mm-diam Al dots through a stainless-steel mask in an electron gun evaporation system. The postmetalization anneal (PMA) was always performed for 30 min in a wet N<sub>2</sub> ambient at 450 °C. On part of the samples, a high-temperature anneal at 1000 °C in dry N<sub>2</sub> (30 min) was applied. In the case of Na<sup>+</sup>- and Li<sup>+</sup>-implanted oxides, this led to an almost complete removal of the implanted ions,<sup>8</sup> therefore only the K<sup>+</sup> mobility and in a few cases the Na<sup>+</sup> mobility could be determined in oxides that had been annealed at 1000 °C.

## III. MEASURING TECHNIQUES

We used the isothermal transient ionic current (ITIC) method<sup>1,9</sup> to measure the mobility of Na<sup>+</sup> and Li<sup>+</sup> ions. The principle of this method is the recording of the transient current caused by the mobile ions after a voltage step has been applied to the MOS capacitor at an elevated temperature. As indicated by Stagg,<sup>1</sup> one has to compensate for the charging current of the MOS capacitor. The circuit with which this has been done is schematically drawn in Fig. 1. The fine adjustment (left side of figure) is important, since the ion transient current is very small compared to the charging current. With our setup, mobile ion concentrations as low as 10<sup>10</sup> ions/cm<sup>2</sup> could be measured easily. A proper way to improve the sensitivity is to repeat the experiment several

TABLE I. Projected range of the performed implantation experiments (calculations are based on Ref. 7)

Element	Energy (keV)	$R_p$ (Å)	$\Delta R_p$ (Å)
Li <sup>+</sup>	15	920	380
Na <sup>+</sup>	25	460	260
K <sup>+</sup>	25	250	120

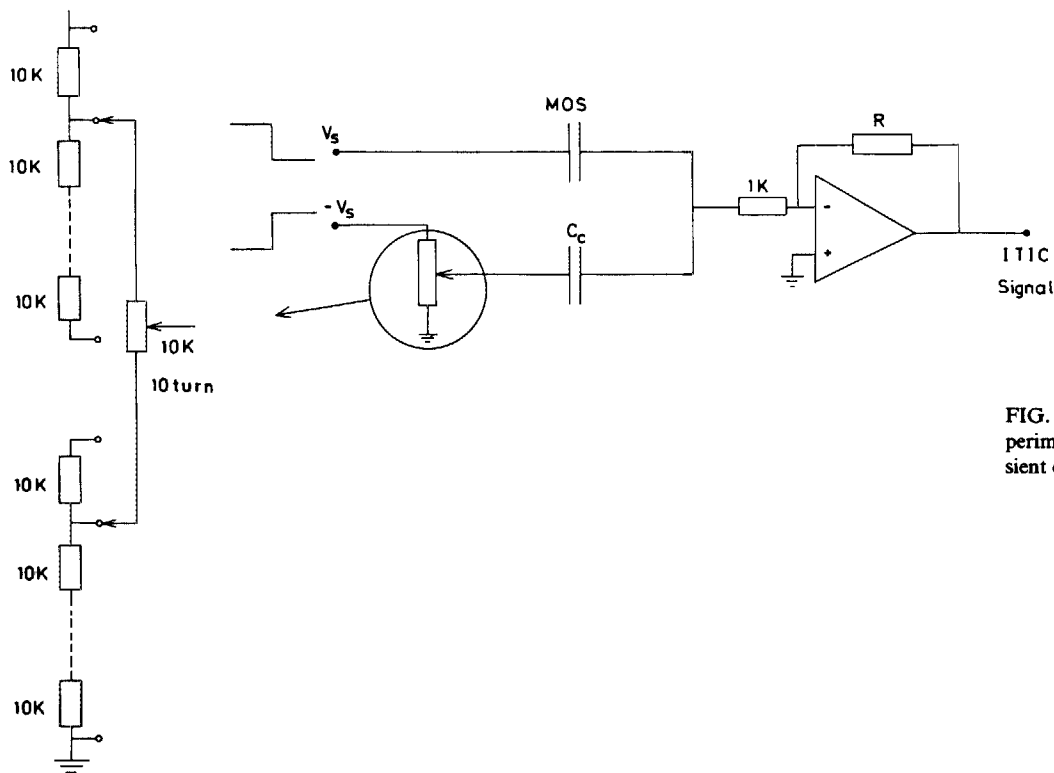

FIG. 1. Compensating circuit ITIC experiments to adjust for the MOS transient current (see text).

times and to average the ITIC signal, thereby improving the signal-to-noise ratio.

The temperature range for the  $\text{Na}^+$  and  $\text{Li}^+$  ITIC measurements was about 100–300 °C. At lower temperatures the emission of the ions from the interface traps is too slow, and at higher temperatures ( $>300$  °C) the transit time (i.e., the period needed to cross the oxide layer) is too short to be measured accurately.

The evaluation of the ITIC curves has been carried out by means of curve fitting with a computer program, based on a recently developed model that includes diffusion, drift, and detrapping.<sup>10</sup>

The mobility of the  $\text{K}^+$  ions can be measured in the same way.<sup>1</sup> However, we have observed that the ITIC technique is rather insensitive with respect to  $\text{K}^+$  ion drift. Our group has developed a more sensitive technique, based on triangular voltage sweep (TVS) measurements.<sup>2</sup> Therefore, the ITIC method has been used only as a check on the TVS results. The temperature range for the  $\text{K}^+$  mobility measurements was 350–450 °C.

## IV. RESULTS

### A. Sodium

The mobility of  $\text{Na}^+$  ions has been measured in a series of differently prepared oxides. The measurements were not restricted to  $\text{Na}^+$ -implanted oxides, and other oxides have been used when the background sodium contamination was high enough to be measured by means of the ITIC method. In this way,  $\text{Na}^+$  drift in  $\text{K}^+$ -implanted oxides has been measured; the  $\text{Na}^+$  and  $\text{K}^+$  ion currents are easily distinguished.<sup>1</sup> Figure 2 shows an example of an ITIC curve corresponding to  $\text{Na}^+$  ions. The shape of the curve is characteristic for all the ITIC measurements that we have performed.

The mobility follows directly from the calculated fitting curve.<sup>10</sup>

The mobility  $\mu(T)$  of the  $\text{Na}^+$  ions has been measured at various temperatures. An example of the observed relation between  $\ln \mu(T)$  and  $1000/T$  ( $T$  is the absolute temperature) is plotted in Fig. 3. The measuring points scatter around a straight-line fit, which corresponds to the equation

$$\mu(T) = \mu_0 \exp(-E_a/kT). \quad (1)$$

In this way, the pre-exponential factor  $\mu_0$  and the activation energy  $E_a$  have been determined for a number of samples. The results are listed in Table II. The value of  $\Delta E_a$  corresponds to a 95% confidence interval of the activation energy. The average electric field  $E_{ox}$  during the measurement is also listed in Table II. Inspection of Table II shows

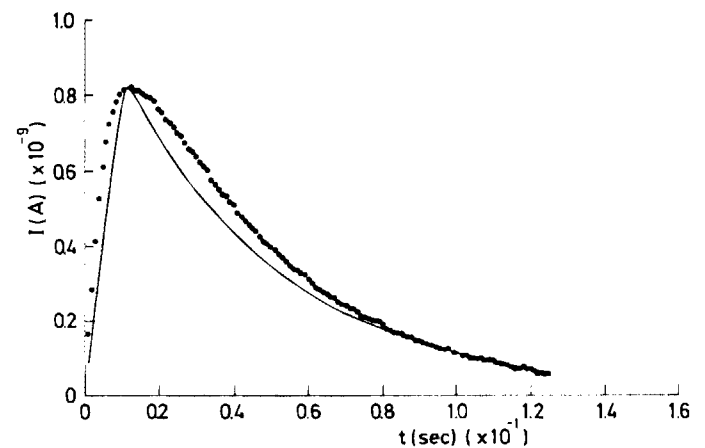

FIG. 2. ITIC curves corresponding to a  $\text{Na}^+$  ion-implanted oxide. Dots—experimental:  $T = 150$  °C,  $E_{ox} = 1.05 \times 10^6$  V/cm,  $d = 1000$  Å. Solid curve—theoretical:  $N_m = 3.3 \times 10^{11}$   $\text{Na}^+/\text{cm}^2$ ,  $\mu = 8.4 \times 10^{-10}$   $\text{cm}^2/\text{V s}$ .

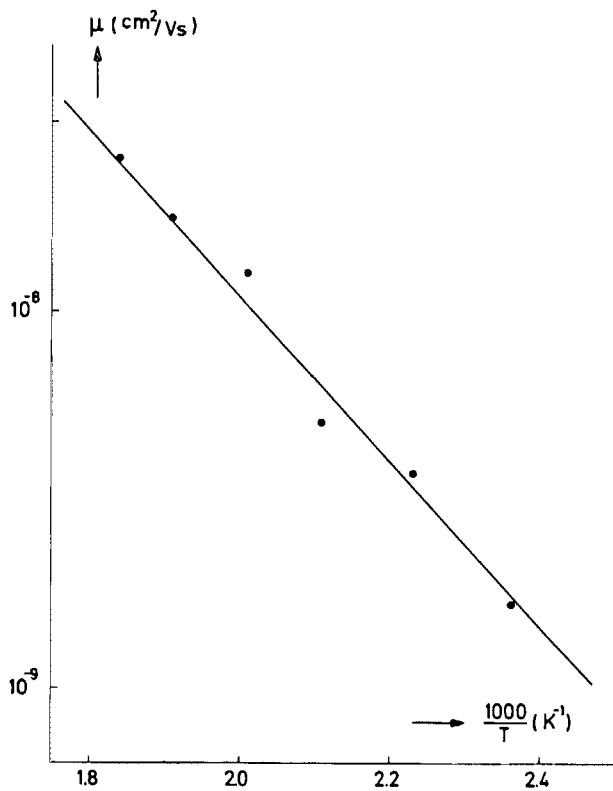

FIG. 3. Example of the Na<sup>+</sup> mobility dependence on the inverse of the absolute temperature.

that there exists no apparent correlation between the activation energy for Na<sup>+</sup> ion drift and any of the experimental or technological parameters like the implantation dose, the

electric field, etc. We conclude that the observed variation of  $E_a$  is due to measuring errors in the  $\mu(T)$  values. Therefore, we have determined a weighted average with a weight factor of  $1/\Delta E_a$  for  $E_a$  and  $\mu_0$  (in order to get a proper  $\mu_0$  value, we have calculated the weighted average of  $\ln \mu_0$ ):

$$\bar{E}_a(\text{Na}^+) = 0.44 \pm 0.09 \text{ eV},$$

$$\bar{\mu}_0(\text{Na}^+) = 3.5 \times 10^{-4} \text{ cm}^2/\text{V s (within a factor of 12)}.$$

## B. Lithium

Measurements of the Li<sup>+</sup> ion mobility have been performed on Li<sup>+</sup> ion-implanted oxides with a typical thickness of 1000 Å. Since Na<sup>+</sup> and Li<sup>+</sup> ions in SiO<sub>2</sub> have rather similar properties, care must be taken to ensure that the sodium concentration is much less than the lithium concentration in the oxide. The best way to distinguish Li<sup>+</sup> and Na<sup>+</sup> ions by an electrical method is to use the thermally stimulated ionic current (TSIC) technique.<sup>13</sup> Such measurements show that Li<sup>+</sup> ions are more deeply trapped than Na<sup>+</sup> ions near the Si/SiO<sub>2</sub> interface.<sup>11</sup> Further evidence that Li<sup>+</sup> ions are measured comes from the observed increase of the mobile ion concentration with the implanted lithium dose. When the implanted dose is increased from  $3 \times 10^{11}$  to  $3 \times 10^{13}$  Li<sup>+</sup>/cm<sup>2</sup>, the mobile ion concentration increases from about  $2 \times 10^{11}$  to about  $5 \times 10^{12}$  cm<sup>-2</sup>.<sup>11</sup>

The observation that Li<sup>+</sup> and Na<sup>+</sup> ions behave rather similarly is illustrated in Fig. 4, where ITIC curves for both types of ions are shown. These curves are recorded under equal experimental conditions. The mobility data corresponding to Li<sup>+</sup> ion drift are given in Table III. Again there is no correlation between  $E_a$  and the implantation dose or

TABLE II. Mobility data for Na<sup>+</sup> drift in thermally grown SiO<sub>2</sub> films.

Oxide description <sup>a)</sup>	$E_{ox}$ (MV/cm)	$E_a$ (eV)	$\Delta E_a$ (eV)	$\mu_0$ (10 <sup>-3</sup> cm <sup>2</sup> /V s)	$\Delta\mu_0/\mu_0$
$3 \times 10^{11}$ Na <sup>+</sup> /cm <sup>2</sup> , dry	0.55	0.40	0.10	$6.8 \times 10^{-2}$	10
	1.05	0.39	0.05	$4.0 \times 10^{-2}$	4
$3 \times 10^{11}$ Na <sup>+</sup> /cm <sup>2</sup> , wet	0.47	0.43	0.10	$1.4 \times 10^{-1}$	12
	0.89	0.42	0.07	$9.5 \times 10^{-2}$	6
$3 \times 10^{12}$ Na <sup>+</sup> /cm <sup>2</sup> , dry	1.05	0.48	0.15	$4.2 \times 10^{-1}$	65
$3 \times 10^{13}$ Na <sup>+</sup> /cm <sup>2</sup> , dry	0.55	0.37	0.17	$4.5 \times 10^{-2}$	140
	1.05	0.30	0.19	$5.0 \times 10^{-3}$	280
$5 \times 10^{11}$ K <sup>+</sup> /cm <sup>2</sup> , wet	0.17	0.50	0.10	1.3	7
	0.34	0.57	0.12	3.3	11
$1 \times 10^{13}$ K <sup>+</sup> /cm <sup>2</sup> , wet, an.	0.22	0.34	0.10	$2.5 \times 10^{-2}$	7
	0.24	0.58	0.19	47	82
not implanted, wet	0.10	0.59	0.13	44	14
	0.20	0.51	0.17	6.3	33
	0.47	0.44	0.08	$2.4 \times 10^{-1}$	8
	0.89	0.42	0.10	$8.6 \times 10^{-2}$	14
not implanted, Chl.	0.43	0.44	0.07	$3.0 \times 10^{-1}$	6
	0.81	0.41	0.13	$1.0 \times 10^{-1}$	25

<sup>a)</sup> dry: oxidation in dry O<sub>2</sub> at 1000 °C.

wet: oxidation in wet O<sub>2</sub> at 1000 °C.

an.: thermal anneal at 1000 °C for 30 min in dry N<sub>2</sub>.

chl.: oxidation in a 2% C<sub>2</sub>H<sub>3</sub>Cl<sub>3</sub>/O<sub>2</sub> atmosphere at 1000 °C.

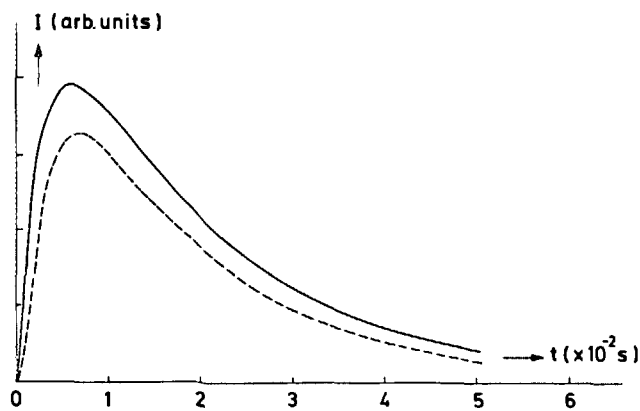

FIG. 4. ITIC curves for Na<sup>+</sup>- and Li<sup>+</sup>-implanted oxides, recorded at  $T = 175^\circ\text{C}$ ; the applied field was 1.05 MV/cm. Solid curve: lithium. Interrupted curve: sodium.

the electric field; the weighted averages of  $E_a$  and  $\mu_0$  are in this case

$$\bar{E}_a(\text{Li}^+) = 0.47 \pm 0.08 \text{ eV},$$

$$\bar{\mu}_0(\text{Li}^+) = 4.5 \times 10^{-4} \text{ cm}^2/\text{V s (within a factor of 10)}.$$

These results are not significantly different from the values found for Na<sup>+</sup> ion drift in the preceding section.

### C. Potassium

We have already remarked that the K<sup>+</sup> mobility has been measured with the TVS technique. In this section a brief review of the method will be presented; for more details, we refer to the literature.<sup>2</sup> When K<sup>+</sup> ions (and Na<sup>+</sup> ions) are present in the oxide, we observe two peaks in the TVS current at elevated temperatures ( $T > 350^\circ\text{C}$ ). By variation of the sweep rate  $\alpha$ , defined by

$$\alpha = dV_G/dt, \quad (2)$$

where  $V_G$  denotes the applied bias on the metal electrode, we induce a shift of the K<sup>+</sup> peak along the voltage axis (see Fig. 5). According to a simple drift model,<sup>2</sup> this shift  $\Delta V$  is related to the K<sup>+</sup> mobility in the following manner:

$$\mu(\text{K}^+) = 2\alpha d^2/(\Delta)^2, \quad (3)$$

where  $d$  denotes the oxide thickness. In Fig. 6 we show an example of the linear relationship between the square root of  $\alpha$  and  $\Delta V$ . From the slope of the line fit, we obtain the mobility  $\mu(\text{K}^+)$ . Since the mobility is dependent only on the bulk

properties of the oxide layer, we expect a constant  $\mu$  value for different  $d$  values. We have checked this by varying  $d$  from 700 to 10 400 Å. Below 2500-Å thickness, we observed a decrease of  $\mu$ , which suggests that the drift model is not suited to determine the mobility in the case of oxides thinner than 2500 Å.<sup>11</sup> We have measured the K<sup>+</sup> mobility as a function of the temperature in the range 350–450 °C for five samples. The results on two of these samples are plotted in Fig. 7, together with the line fits. In Table IV the calculated activation energies and pre-exponential factors of the K<sup>+</sup> mobility are listed. Again, the weighted average of  $E_a$  and  $\mu_0$  have been determined:

$$\bar{E}_a(\text{K}^+) = 1.04 \pm 0.10 \text{ eV},$$

$$\mu_0(\text{K}^+) = 2.5 \times 10^{-3} \text{ cm}^2/\text{V s (within a factor of 8)}.$$

A few mobility values have been determined by means of the ITIC technique. Both the absolute values and the temperature dependence agree very well with the TVS results.

## V. DISCUSSION

### A. Sodium

Our results on the Na<sup>+</sup> mobility in thermally grown SiO<sub>2</sub> films are significantly different from those reported by others.<sup>1,12,13</sup> The referred workers have found activation energy values in the range 0.63–0.70 eV, whereas our  $E_a$  value was  $0.44 \pm 0.09$  eV. For the sake of comparison we have plotted our  $\mu(T)$  and those of Refs. 1, 12, and 13 in Fig. 8. The figure shows that in the low-temperature range ( $T < 100^\circ\text{C}$ ) our line approaches those of Refs. 1 and 12. The deviation becomes large at higher temperatures.

We can think of the following reasons for the observed difference:

(a) *Structure and purity of the oxides.* The other reports deal with oxides grown at higher temperatures, viz., 1100 °C,<sup>1</sup> 1150 °C,<sup>12</sup> and 1200 °C.<sup>13</sup> Our oxides were grown at 1000 °C. The oxidation temperature influences the structure and the mass density of the oxides.<sup>14</sup>

Moreover, the purity of the oxides may be quite different. The cleanliness of the sample preparation techniques has been improved in the last decade. The way in which the samples are intentionally contaminated with sodium may also affect the purity of the oxides.

(b) *Measuring method.* The space-charge-limited current method, used by Hofstein,<sup>13</sup> needs very high mobile ion

TABLE III. Mobility data for Li<sup>+</sup> drift in thermally grown SiO<sub>2</sub> films.

Implanted dose (Li <sup>+</sup> /cm <sup>2</sup> )	$E_{ox}$ (MV/cm)	$E_a$ (eV)	$\Delta E_a$ (eV)	$\mu_0$ (10 <sup>-3</sup> cm <sup>2</sup> /V s)	$\Delta\mu_0/\mu_0$
$3 \times 10^{11}$	0.55	0.47	0.13	$3.1 \times 10^{-1}$	25
$3 \times 10^{11}$	1.05	0.39	0.04	$3.5 \times 10^{-2}$	3
$1 \times 10^{12}$	0.45	0.46	0.05	$5.1 \times 10^{-1}$	3
$1 \times 10^{12}$	0.85	0.51	0.07	1.4	7
$3 \times 10^{12}$	0.55	0.51	0.08	1.7	9
$3 \times 10^{12}$	1.05	0.57	0.05	4.3	4
$3 \times 10^{13}$	0.55	0.47	0.24	$4.0 \times 10^{-1}$	670
$3 \times 10^{13}$	1.05	0.35	0.16	$1.4 \times 10^{-2}$	79

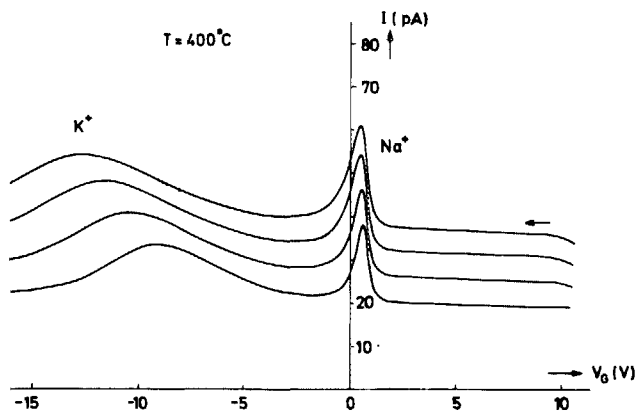

FIG. 5. Example of the effect of the sweep rate  $\alpha$  on the  $K^+$  peak in the TVS current. The thickness of the wet oxide was 6120 Å. The sweep rates are: (a)  $\alpha = 462$  MV/s; (b) 597 MV/s; (c) 736 MV/s; (d) 850 MV/s.

concentrations ( $> 10^{13} \text{ cm}^{-2}$ ), which may influence the mobility. Kriegler and Devenyi<sup>12</sup> used an indirect method, i.e., differentiation of the flat-band voltage shift  $\Delta V_{FB}$  with respect to time. Our impression is that this method is not as accurate as the direct ITIC method; Kriegler and Devenyi<sup>12</sup> report an uncertainty of 0.1 eV for the activation energy. Stagg<sup>1</sup> used the ITIC method, just as we do. However, his determination of the transit time from the ITIC plots is different. Stagg assumes that the time of the current maximum  $t_m$  is coincident with the transit time  $t_{tr}$ . Calculations based on our model<sup>10</sup> show that generally  $t_{tr}$  is about 10% less than  $t_m$ . Moreover, Stagg also observed so-called drift-limited transient currents, which are more or less constant during the transit period. From his paper, it is not clear how  $t_{tr}$  is exactly determined in case of this current behavior. Drift-limited currents are to be expected when the transit time is long compared to the emission time. Stagg observed such currents in the case of a 5750-Å-thick oxide. However, our experiments on thicker oxides (10 390 Å) did not yield similar results. In fact, all measurements yielded ITIC curves similar in shape to those plotted in Fig. 4, which indicates that the emission time is always larger than the transit time.

(c) *Different temperature range of the measurements.* From Fig. 8, it is obvious that our temperature range of 100–

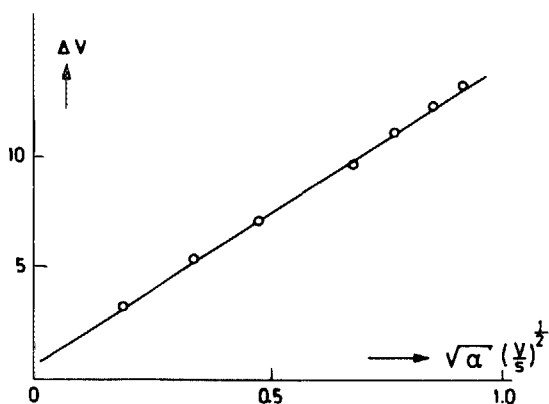

FIG. 6. Illustration of the linear relation between the voltage shift  $\Delta V$  of the  $K^+$  peak and the square root of the sweep rate. The mobility of the  $K^+$  ions follows from the slope of the line.

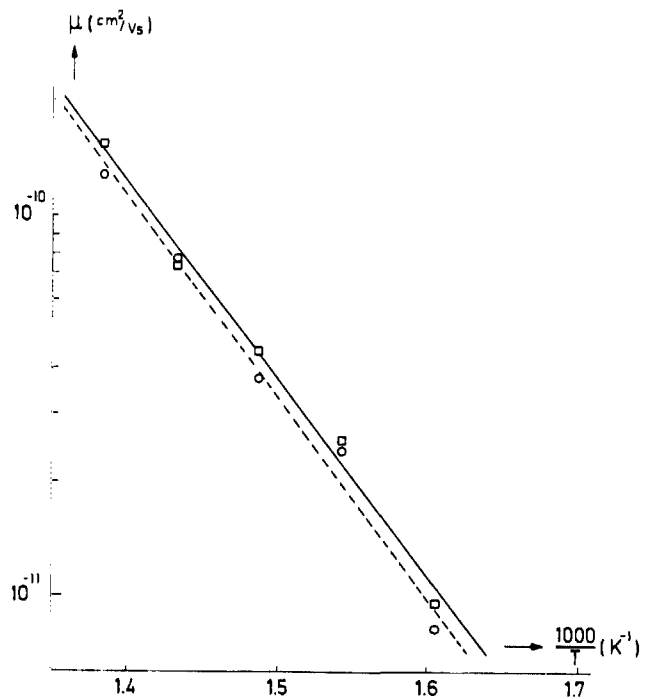

FIG. 7.  $K^+$  mobility as a function of the inverse absolute temperature. The circular dots and the interrupted line correspond to a wet oxide ( $d = 2540$  Å), the squares and the straight line to a wet + annealed oxide ( $d = 2540$  Å).

300 °C is rather high compared to the other measurements. It is possible that the mobility of sodium in  $\text{SiO}_2$  cannot be described with a single activation energy in the range 30–300 °C.

## B. Lithium

In the case of  $\text{Li}^+$  ion drift in thermally grown  $\text{SiO}_2$ , no mobility values have been published up to now. Snow *et al.*<sup>15</sup> have determined an activation energy value of 0.48 eV for lithium migration in  $\text{SiO}_2$ , but they failed to separate the mobility from the interface detrapping effects. Nevertheless, the agreement with our  $E_a$  value of 0.47 eV is remarkable. Woods and Williams<sup>16</sup> showed that  $\text{Na}^+$  and  $\text{Li}^+$  ions could be drifted through  $\text{SiO}_2$  films at room temperature, but quantitative results were not given.

## C. Potassium

Previous results on the mobility of  $K^+$  ions in  $\text{SiO}_2$  have been reported by Stagg<sup>1</sup> and by Hillen *et al.*<sup>2</sup> Comparison of

TABLE IV. Mobility data for  $K^+$  drift in thermally grown  $\text{SiO}_2$  films.

Oxide description <sup>a)</sup>	$d$ (Å)	$E_a$ (eV)	$\Delta E_a$ (eV)	$\mu_0$ ( $10^{-3} \text{ cm}^2/\text{V s}$ )	$\Delta\mu_0/\mu_0$
$5 \times 10^{11} \text{ K}^+/\text{cm}^2$ , wet	2540	1.04	0.11	2.6	8
$10^{13} \text{ K}^+/\text{cm}^2$ , wet, an.	2540	1.03	0.11	2.2	8
$5 \times 10^{11} \text{ K}^+/\text{cm}^2$ , wet	10 390	1.05	0.10	3.9	7
$10^{13} \text{ K}^+/\text{cm}^2$ , wet, an.	10 390	0.98	0.15	1.3	15
$5 \times 10^{11} \text{ K}^+/\text{cm}^2$ , dry	3410	1.07	0.10	2.3	7

<sup>a)</sup> dry: oxidation in dry  $\text{O}_2$  at 1000 °C.

wet: oxidation in wet  $\text{O}_2$  at 1000 °C.

an.: thermal anneal at 1000 °C for 30 min in dry  $\text{N}_2$ .

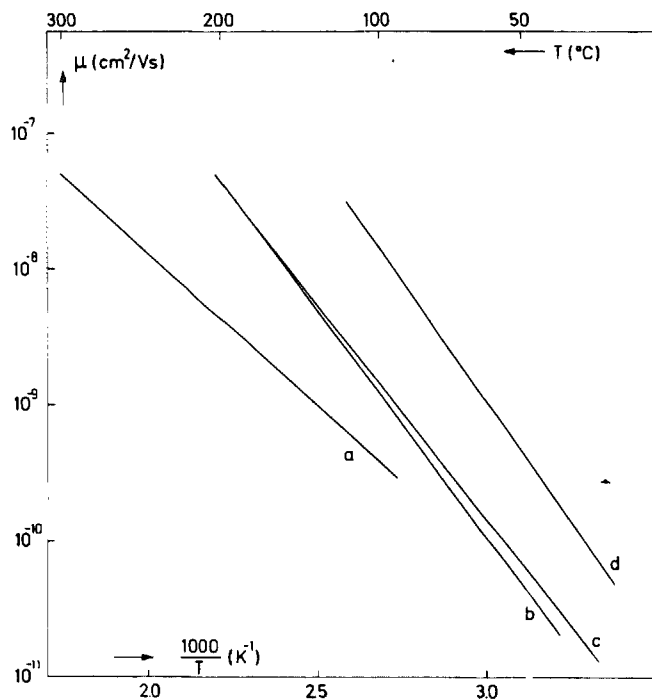

FIG. 8. Comparison of the Na<sup>+</sup> mobilities, as measured by different workers: (a) this paper; (b) Stagg<sup>1</sup>; (c) Kriegler and Devenyi<sup>12</sup>; (d) Hofstein.<sup>13</sup>

these results with ours shows that the activation energies are in reasonable agreement; the factor  $\mu_0$ , however, appears to be different. It seems as if  $\mu_0$  increases with the oxidation temperature, but the data are too limited to draw definite conclusions.

## VI. DEPENDENCE OF THE ACTIVATION ENERGY ON THE ION RADIUS; THE ANDERSON-STUART MODEL

Anderson and Stuart have developed a model to calculate the activation energy of interstitial ion diffusion in sili-

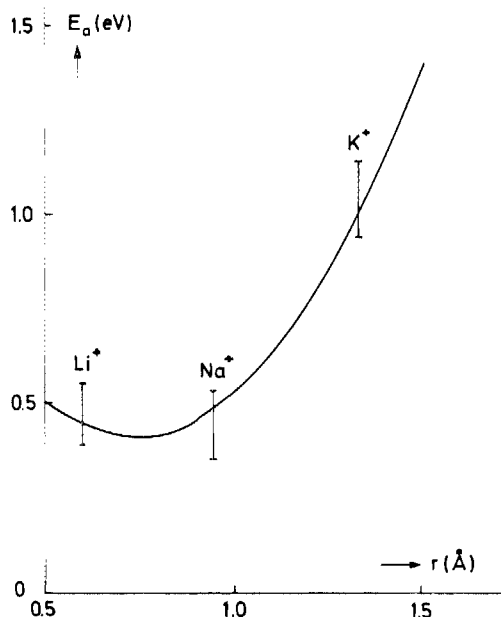

FIG. 9. Three measured values of the activation energy for the mobility, fitted by a theoretical curve. The curve corresponds to the Anderson-Stuart model (see text).

cate glasses;<sup>6</sup> we shall refer to this model simply as the Anderson-Stuart model. In the case of alkali ions, the model leads to the following relation:

$$E_a(r) = \frac{8.2(2.1 - r)}{\gamma(r + 1.4)} + 0.4G(r - 0.6)^2 \text{ [eV]}, \quad (4)$$

where  $r$  denotes the ion radius (in Angstroms),  $\gamma$  is the so-called covalency parameter, and  $G$  the shear modulus (in units of  $10^{11}$  dyn/cm<sup>2</sup>). The first term on the right-hand side of Eq. (4) accounts for the Coulomb interaction between the interstitial alkali ion and the most nearby oxygen ion. The second term stands for the strain energy, i.e., the amount of energy needed by the cation to widen the narrow "doorway" between two interstitial positions. The radius of these doorways has been estimated to be 0.6 Å.<sup>6</sup>

We have assumed that the activation energy of the mobility is equal to that of diffusion, which is plausible since the conduction mechanism (interstitial hopping) is almost certainly the same for both processes. Therefore, our results on Li<sup>+</sup>, Na<sup>+</sup>, and K<sup>+</sup> drift deliver three measuring points on which Eq. (4) can be fitted by variation of  $\gamma$  and  $G$ . The result is shown in Fig. 9. The fitting curve corresponds to

$$\gamma = 13.7,$$

$$G = 3.34 \times 10^{11} \text{ dyn/cm}^2.$$

The figure shows that Eq. (4) gives a good description of the observed  $E_a$  or  $r$  dependence. Moreover, the calculated  $G$  value is in very good agreement with an extrapolation of the corresponding values, tabulated in Ref. 6 on Na<sub>2</sub>O-SiO<sub>2</sub> glasses. The value for  $\gamma$ , however, is much higher than the predicted value of 3.85, viz., the dielectric constant of thermally grown SiO<sub>2</sub>. The Anderson-Stuart model does not supply a theoretical value for  $\gamma$ , but the authors state that, in practice,  $\gamma$  is always about equal to the dielectric constant.

From the curve in Fig. 9, we can understand why ions bigger than K<sup>+</sup>, like Rb<sup>+</sup> and Cs<sup>+</sup>, are not mobile in thermally grown oxide films. The steep increase of  $E_a$  with  $r$  above  $r = 1.3$  Å leads to high activation energies for the conduction of these ions (e.g., Rb<sup>+</sup>:  $E_a = 1.35$  eV).

## VII. SUMMARY AND CONCLUSIONS

The mobility of Na<sup>+</sup>, Li<sup>+</sup>, and K<sup>+</sup> ions in thermally grown SiO<sub>2</sub> layers has been measured. The oxidation temperature was 1000 °C; the doping of the oxides has been performed by means of ion implantation.

From ITIC measurements at various temperatures in the range 100–300 °C, we have determined the average activation energies and the pre-exponential factors for the Na<sup>+</sup> and the Li<sup>+</sup> ion mobility. The results were, in the case of Na<sup>+</sup>,

$$\bar{E}_a = 0.44 \pm 0.09 \text{ eV},$$

$$\bar{\mu}_0 = 3.5 \times 10^{-4} \text{ cm}^2/\text{V s (within a factor of 12),}$$

and in the case of Li<sup>+</sup>,

$$\bar{E}_a = 0.47 \pm 0.08 \text{ eV},$$

$$\bar{\mu}_0 = 4.5 \times 10^{-4} \text{ cm}^2/\text{V s (within a factor of 10).}$$

These results indicate that the mobilities of Na<sup>+</sup> and Li<sup>+</sup> ions in SiO<sub>2</sub> films are about equal.



From TVS measurements in the range 350–450 °C, we have determined the following values for the K<sup>+</sup> mobility:

$$\bar{E}_a = 1.04 \pm 0.10 \text{ eV},$$

$$\bar{\mu}_0 = 2.5 \times 10^{-3} \text{ cm}^2/\text{V s (within a factor of 8)}.$$

The presented values for the activation energy can be explained reasonably by the Anderson–Stuart model.<sup>6</sup> However, a refinement of this model is needed with respect to the meaning and the value of the covalency parameter  $\gamma$ .

#### ACKNOWLEDGMENTS

We are indebted to S. Bakker and M. Mulder for the preparation of the samples. This research was financially supported by the Foundation for Fundamental Research on Matter (Stichting F.O.M.).

<sup>1</sup>J. P. Stagg, *Appl. Phys. Lett.* **31**, 532 (1977).

<sup>2</sup>M. W. Hillen, G. Greeuw, and J. F. Verwey, *J. Appl. Phys.* **50**, 4834 (1979).

<sup>3</sup>M. R. Boudry and J. P. Stagg, *J. Appl. Phys.* **50**, 942 (1979).

<sup>4</sup>G. Sixt and A. Goetzberger, *Appl. Phys. Lett.* **19**, 478 (1971).

<sup>5</sup>E. H. Nicollian and J. R. Brews, *MOS Physics and Technology* (Wiley Interscience, New York, 1982), p. 759.

<sup>6</sup>O. L. Anderson and D. A. Stuart, *J. Am. Ceram. Soc.* **37**, 573 (1954).

<sup>7</sup>J. P. Biersack and J. F. Ziegler, *Ion Implantation Techniques* (Springer Series in Electrophysics), edited by H. Ryssel and H. Glawischnig (Springer, Berlin, 1982), p. 157.

<sup>8</sup>G. Greeuw, S. Bakker, and J. F. Verwey, *Solid-State Electron.* **27**, 77 (1984).

<sup>9</sup>C. R. Viswanathan, Technical Report ECOM-0283-F, University of California, Los Angeles 1973.

<sup>10</sup>G. Greeuw and B. Hoenders, *J. Appl. Phys.* **55**, 3371 (1984).

<sup>11</sup>G. Greeuw, Thesis, State University, Groningen, 1984.

<sup>12</sup>R. J. Kriegler and T. F. Devenyi, *Thin Solid Films* **36**, 435 (1976).

<sup>13</sup>S. R. Hofstein, *Appl. Phys. Lett.* **10**, 291 (1967).

<sup>14</sup>I. Ruge, *Halbleiter-Technologie* (Springer, Berlin, 1975), p. 245.

<sup>15</sup>E. H. Snow, A. S. Grove, B. E. Deal, and C. T. Sah, *J. Appl. Phys.* **36**, 1664 (1965).

<sup>16</sup>M. H. Woods and R. Williams, *J. Appl. Phys.* **44**, 5506 (1973).