

University of Groningen

Order parameters of some nematic p, p' substituted tolans as determined by polarized Raman scattering

Dalmolen, L. P. G.; de Jeu, W. H.

Published in:
Journal of Chemical Physics

DOI:
[10.1063/1.444726](https://doi.org/10.1063/1.444726)

IMPORTANT NOTE: You are advised to consult the publisher's version (publisher's PDF) if you wish to cite from it. Please check the document version below.

Document Version
Publisher's PDF, also known as Version of record

Publication date:
1983

[Link to publication in University of Groningen/UMCG research database](#)

Citation for published version (APA):

Dalmolen, L. P. G., & de Jeu, W. H. (1983). Order parameters of some nematic p, p' substituted tolans as determined by polarized Raman scattering. *Journal of Chemical Physics*, 78(12), 7353-7361.
<https://doi.org/10.1063/1.444726>

Copyright

Other than for strictly personal use, it is not permitted to download or to forward/distribute the text or part of it without the consent of the author(s) and/or copyright holder(s), unless the work is under an open content license (like Creative Commons).

Take-down policy

If you believe that this document breaches copyright please contact us providing details, and we will remove access to the work immediately and investigate your claim.

Downloaded from the University of Groningen/UMCG research database (Pure): <http://www.rug.nl/research/portal>. For technical reasons the number of authors shown on this cover page is limited to 10 maximum.

Order parameters of some nematic p, p' substituted tolans as determined by polarized Raman scattering

L. G. P. Dalmolen, and W. H. de Jeu

Citation: *The Journal of Chemical Physics* **78**, 7353 (1983); doi: 10.1063/1.444726

View online: <https://doi.org/10.1063/1.444726>

View Table of Contents: <http://aip.scitation.org/toc/jcp/78/12>

Published by the [American Institute of Physics](#)

Articles you may be interested in

[Polarized Raman scattering studies of orientational order in uniaxial liquid crystalline phases](#)

The Journal of Chemical Physics **66**, 4635 (1977); 10.1063/1.433720

[Physical studies of nematic azoxybenzenes. II. Refractive indices and the internal field](#)

The Journal of Chemical Physics **68**, 109 (1978); 10.1063/1.435499

PHYSICS TODAY

WHITEPAPERS

ADVANCED LIGHT CURE ADHESIVES

Take a closer look at what these environmentally friendly adhesive systems can do

READ NOW

PRESENTED BY
 **MASTERBOND**
ADHESIVES | SEALANTS | COATINGS

Order parameters of some nematic p , p' substituted tolans as determined by polarized Raman scattering

L. G. P. Dalmolen and W. H. de Jeu

Solid State Physics Laboratory, University of Groningen, Melkweg 1, 9718 EP Groningen, Netherlands
(Received 2 December 1982; accepted 2 March 1983)

The order parameters $\langle P_2 \rangle$ and $\langle P_4 \rangle$ of three nematic compounds have been determined by polarized Raman scattering. Results obtained with p -pentyl- p' -cyanobiphenyl (5CB) agree well with published data. Next the influence of a strongly polar cyano end group on the order parameters was investigated. This was done by comparing two nematic liquid crystals of the tolane class, namely p -heptyl- p' -cyanotolane and p -heptyl- p' -methoxytolane, which have an almost identical geometrical shape. In spite of the difference in polarity hardly any difference in the order parameters $\langle P_2 \rangle$ and $\langle P_4 \rangle$ of both compounds could be observed. $\langle P_2 \rangle$ and $\langle P_4 \rangle$ of both tolans show approximately mean field behavior in contrast to the low $\langle P_4 \rangle$ of 5CB.

I. INTRODUCTION

In nematic liquid crystals the elongated molecules are more or less aligned along a certain preferred direction, the director \vec{n} . There is uniaxial symmetry around \vec{n} , while the directions \vec{n} and $-\vec{n}$ are equivalent. The orientational order can be described by an orientational distribution-function¹ $f(\beta)$, where β is the angle between the long axis of the molecules (which are assumed to be effectively cylinder symmetric) and the director. The number of molecules making an angle between β and $\beta + d\beta$ with the director is given by

$$N(\beta)d\beta = f(\beta) 2\pi \sin(\beta) d\beta .$$

Knowledge of $f(\beta)$ is of primary importance in testing theoretical results for the phase transition isotropic liquid to nematic, which necessarily involves a change from a constant orientational distribution function to an anisotropic one. There are only a few experimental methods that allow, at least in principle, the measurement of the complete orientational distribution function, e.g., x-ray² and neutron³ scattering. However, to use these methods one needs absolute intensity measurements, which are not easily obtained. This is reflected in the limited accuracy of the results. Alternatively it is useful to expand $f(\beta)$ as

$$f(\beta) = \sum_{l=0}^{\infty} \frac{1}{2} (2l+1) \langle P_{2l} \rangle P_{2l}(\cos \beta) ,$$

where the coefficients $\langle P_{2l} \rangle$ are the order parameters. The first three are given by

$$\langle P_0 \rangle = 1 ,$$

$$\langle P_2 \rangle = \frac{1}{2} \langle 3 \cos^2 \beta - 1 \rangle ,$$

$$\langle P_4 \rangle = \frac{1}{8} \langle 35 \cos^4 \beta - 30 \cos^2 \beta + 3 \rangle .$$

Only the even terms in the Legendre development of $f(\beta)$ are nonzero, as due to the equivalence of \vec{n} and $-\vec{n}$ one has $f(\pi - \beta) = f(\beta)$.

The order-parameter $\langle P_2 \rangle$ can be measured by usual techniques probing a second order tensor property, as diamagnetic anisotropy,⁴ birefringence,⁵ nuclear magnetic resonance⁶ (NMR) experiments, etc. The variation of $\langle P_2 \rangle$ over the nematic temperature range is always reported to be in reasonable agreement with mean

field theories describing the ordering in nematic liquid crystals.

Recently Jen *et al.*⁷ reported a method to find $\langle P_4 \rangle$ as well as $\langle P_2 \rangle$ via depolarized Raman scattering. This method depends on the measurement of the degree of depolarization of the Raman light scattered by one of the molecular modes of vibration in uniformly aligned samples of a nematic liquid crystal. The few results for $\langle P_4 \rangle$ obtained in this way indicate often that $\langle P_4 \rangle$ is much lower than predicted by theory, while even negative values for $\langle P_4 \rangle$ have been reported.⁷⁻⁹

Several possibilities have been proposed to explain the low values of $\langle P_4 \rangle$. It has been attributed to local field corrections^{10,18} (see the Discussion) or to the flexibility of the alkyl chains of the molecules.⁸ Besides that, one could question the assumption of cylindrical symmetry of the molecules, or consider the influence of formation of molecular complexes. On the other hand, the reliability of some of the reported measurements is somewhat questionable because several corrections have to be applied to the measured data, which in fact is not always done. Also the measurement of the depolarization of the scattered light is more complicated than it might seem at a first glance; the Raman setup has to be very carefully aligned and calibrated. In our opinion the measurement of $\langle P_4 \rangle$ given in Ref. 10 is one of the most reliable ones. These measurements again indicate a low value of $\langle P_4 \rangle$, though negative values were not proven within experimental error. As the understanding of the orientational distribution function of nematics is of fundamental importance for all other work in this field, we thought it worthwhile to continue this work on some well chosen compounds, taking care to connect with existing data in the literature.

We focused our attention to the problem of the formation of molecular complexes which could influence $\langle P_4 \rangle$ and has not been accounted for in any theory yet. Up to now most measurements have been carried out on highly polar and polarizable compounds, such as the alkyl-cyanobiphenyls. This is probably because the cyano-stretch vibration line is very strong, strongly polarized, and well isolated from other lines in the spectrum. Also the cyano group is rigidly attached to the rigid central

core of the molecule. Measurement of the ordering of the axes of the vibration is thus typical for the ordering of the whole molecule, assuming rigid molecules. On the other hand, in compounds with a cyano end-group molecular complexes are being formed. From dielectric permittivity measurements one can conclude that there are strong antiparallel correlations of the polar molecules.¹¹ This leads to a series of peculiar effects found in the higher homologs of the cyanobiphenyls and related series of compounds, such as the formation of smectic double layers,¹² or the existence of a reentrant nematic phase.¹³ It seems natural to assume that these correlations could also influence the orientational distribution and thus $\langle P_4 \rangle$. To test this assumption we carried out measurements on two compounds of the tolane class. The first with and the second without a strong dipole, namely:

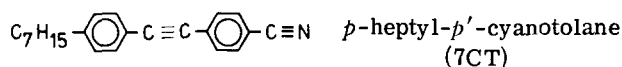

and

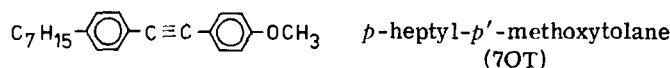

The stretch vibration of the central acetylenic bond in the rigid core of the molecule proves to be very useful for Raman measurements. The geometrical shape of both molecules is almost the same.

The experimental setup has been tested by remeasuring the order parameters of *p*-pentyl-*p'*-cyanobiphenyl (5CB)

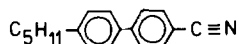

as already published by Miyano.¹⁰ The sources of experimental errors and some of the simplifying assumptions usually made for the measurement of the order parameters have also been investigated carefully.

The plan of this paper is as follows. In the next section we shall discuss the experimental setup and the determination of the so-called depolarization ratios. We summarize the necessary theory in Sec. III. In Sec. IV the experimental results are given, including an analysis of the sensitivity of the order parameters to variations of both the various input parameters and the assumptions that are made. Section V contains a concluding discussion.

II. EXPERIMENTAL

General: Linearly polarized laser light falls on a uniformly aligned liquid crystal sample. The scattered Raman light is depolarized compared to the laser light. The degree of depolarization of the scattered light is then defined as the ratio of the intensity of the scattered light with its polarization parallel and perpendicular to the polarization of the laser light, respectively.

There are three independent scattering geometries with an uniformly aligned sample, depending on the orientation of the director of the sample compared to the polarization of the incident laser beam (see Fig. 1). Two of these geometries use a planar sample, the third

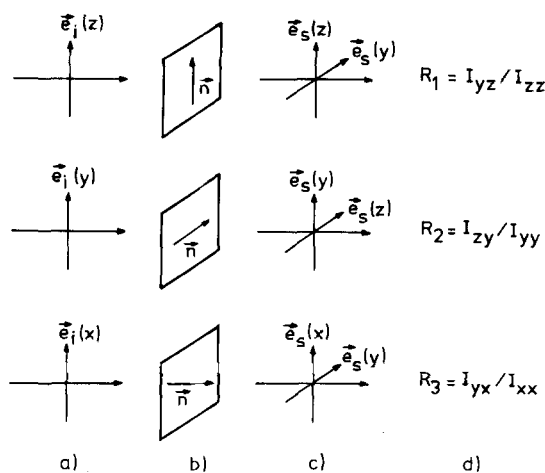

FIG. 1. Scattering geometry and definition of the depolarization ratios; (a) direction of polarization of the laser beam \vec{e}_i , (b) sample with director \vec{n} , (c) polarization components of the scattered light \vec{e}_s , (d) depolarization ratio belonging to the depicted geometry, $R_{180} \equiv R_1$ in the isotropic phase.

a homeotropic one. A fourth depolarization ratio has to be determined in the isotropic phase.

Sample preparation: The sample cell consists of two glass slides of $1.8 \times 1.8 \text{ cm}^2$ held apart by spacers of tungsten ribbon of 25, 50, or 100 μm thickness. The two parts of the cell are glued together with a high temperature resistant two component epoxy resin.

To make uniform homeotropic or uniform planar samples¹⁴ the glass plates were treated prior to the assembly of the cell. In the case of homeotropic alignment the glass slides were first thoroughly cleaned and treated with an acid mixture and then the sample was doped with about 0.1% of a homeotropic coupling agent such as "Saure T" (Merck, Darmstadt). For the samples with planar alignment we used slides coated with para-xylylene (parylene),¹⁵ which were rubbed along one direction with a soft cloth. The direction of rubbing determines the direction of the director of the sample. The quality of the samples was checked under a polarization microscope.

The Raman setup: The experimental setup is schematically shown in Fig. 2. We use a Spectra physics model 171 Ar^+ laser which is run at about 100 mW at the 5145 \AA line. Higher power results in excessive heating of the sample. The output power of the laser is stabilized using the internal reference loop, giving a stability of better than 1%.

The laser beam passes successively through a beam expander, a Claassen prism filter to remove the laser plasma lines, a calcite polarizer to polarize the laser light more completely, and a microscope objective to focus the light on the sample through a hole in a mirror under 45° .

The sample is contained in a home built oven. The temperature is controlled by a Eurotherm PID temperature controller fitted with a platinum resistance thermometer. The temperature can be set between room

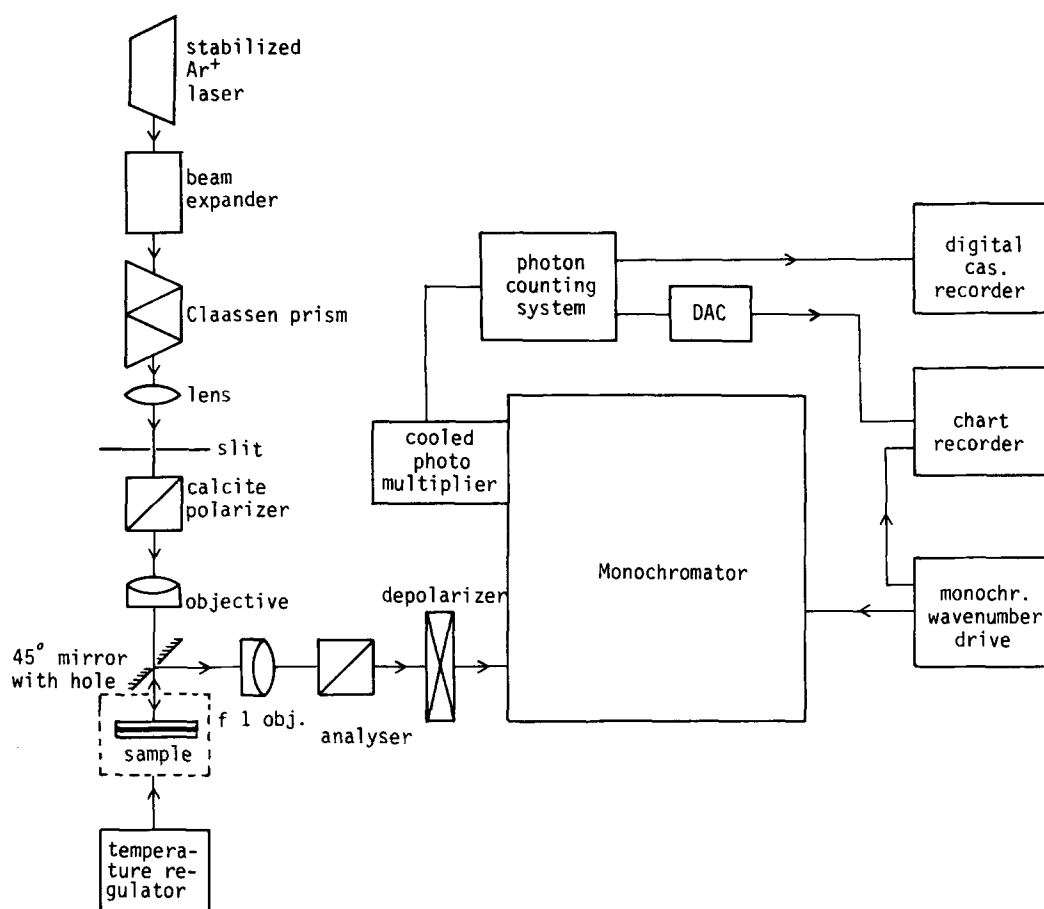

FIG. 2. Schematical drawing of the experimental setup.

temperature and 150°C with 1° intervals. The temperature is regulated within 0.1° .

By turning the planar sample over 90° it is possible to measure R_1 as well as R_2 . The scattered light is focused by an Astro-Berlin $f/1$ objective on the entrance slit of the monochromator, after passing the analyzer (a polaroid sheet) and a quartz wedge depolarizer. The depolarizer is needed because the monochromator has a 1:6 transmission ratio for the two polarization components of the incident light. The monochromator is a Spex type 14018 double monochromator fitted with 1800 grooves/mm gratings and equipped with a Spex wave number drive. The light is detected by an RCA type C13034 GaAs photocathode photomultiplier tube cooled by Peltier elements to about -20°C . The tube is connected to a Spex type DPA-2 photon counting equipment.

The spectra are stored on cassette for later analysis with a computer. At the same time the spectra are drawn on a paper chart recorder.

Experimental problems: The instrument has to be very carefully aligned, especially the calcite polarizer with respect to the director of the sample as well as to the analyzer and to the 45° mirror, otherwise the degree of depolarization cannot be determined with sufficient accuracy. The mirrors should not have dielectric coatings that might introduce spurious changes in polarization. The quartz wedge has to depolarize the light completely, which is best achieved by placing it

as close as possible behind the objective. The optical axis of the wedge should make an angle of 45° with the vertical (entrance slit). The accurate orientation of the wedge turned out to be fairly important.

Determination of the depolarization ratios: To determine the intensity of the scattered light we integrate the intensity under the peak in the spectrum while subtracting a linear background. Hence it is important that the lines under investigation are well separated from other lines in the spectrum. This is indeed the case with the modes of vibration we used to determine the order parameters.

Because the intensity and not the shape of the lines is important with these measurements, quite large slit widths can be used to improve the signal to noise ratio; wider slits cause an increase in the background resulting in a lower signal to noise ratio.

As a first check we measured the depolarization ratio in the isotropic phase $R_{1,so}$ of 5CB, which was found to be 0.267. Miyano reported a value of 0.262.¹⁰ The good agreement gives confidence in the alignment of the instruments in both cases.

III. THEORY

Here we only give a short résumé of the theoretical background of the method which is fully given in Ref. 7. The intensity of the scattered radiation for an ensemble of molecules is given by

$$I_s \sim \langle (\vec{e}_s \vec{R}' \vec{e}_i)^2 \rangle,$$

where \vec{e}_s and \vec{e}_i are unit vectors denoting the direction of the polarization of the electrical field of the scattered and incident light respectively. \vec{R}' is the so-called dressed polarizability (Raman) tensor. On principal axis it reads:

$$\vec{R}' = \begin{pmatrix} a & & \\ & b & \\ & & 1 \end{pmatrix}.$$

The effect of any local field correction is already accounted for in \vec{R}' , which is an effective molecular Raman tensor. The nearest neighbors correlations contribute almost all of the local field corrections. These near-neighbor correlations are not significantly temperature dependent in most condensed phases. Consequently \vec{R}' can be expected to change little over the whole nematic range or even in the isotropic phase, as pointed out in Ref. 7.

In the scattering geometry depicted in Fig. 1 we can define three depolarization ratio's given by

$$R_1 = \langle (\vec{e}_y \vec{R}' \vec{e}_z)^2 \rangle / \langle (\vec{e}_z \vec{R}' \vec{e}_z)^2 \rangle,$$

$$R_2 = \langle (\vec{e}_z \vec{R}' \vec{e}_y)^2 \rangle / \langle (\vec{e}_y \vec{R}' \vec{e}_y)^2 \rangle,$$

$$R_3 = \langle (\vec{e}_y \vec{R}' \vec{e}_x)^2 \rangle / \langle (\vec{e}_x \vec{R}' \vec{e}_x)^2 \rangle,$$

$$R_{1so} \equiv R_1 \text{ in the isotropic phase.}$$

The relation between the measured depolarization ratios R_1 , R_2 , R_3 , R_{1so} , and $\langle P_2 \rangle$, $\langle P_4 \rangle$, a , and b are given by the formulas below:

$$R_1 = C_N \langle \alpha_{yz}^2 \rangle / \langle \alpha_{zz}^2 \rangle,$$

$$R_2 = \langle \alpha_{xy}^2 \rangle / (C_N \langle \alpha_{yy}^2 \rangle),$$

$$R_3 = \langle \alpha_{yx}^2 \rangle / \langle \alpha_{xx}^2 \rangle,$$

$$C_N = \left(\frac{n_g + n_e}{n_g + n_o} \right)^2.$$

n_g , n_o , and n_e are the index of refraction of the glass slides and the ordinary and extraordinary index of refraction of the liquid crystalline sample, respectively. C_N is a correction factor for the difference in the reflection and refraction of the two polarization components of the scattered light at the liquid crystal—glass interface. Finally:

$$\begin{aligned} A^{-2} \langle \alpha_{xx}^2 \rangle &= 1/9 + 3B/16 + C/4 + D/18 + 11D^2/288 \\ &\quad + (B/8 + C/2 - D/6 - 5D^2/48) \langle \cos^2 \beta \rangle \\ &\quad + (3B/16 - 3C/4 + 3D^2/32) \langle \cos^4 \beta \rangle, \end{aligned}$$

$$\begin{aligned} A^{-2} \langle \alpha_{yy}^2 \rangle &= B/16 + C/4 + D^2/32 + (3B/8 - D^2/16) \langle \cos^2 \beta \rangle \\ &\quad + (B/16 - C/4 + D^2/32) \langle \cos^4 \beta \rangle, \end{aligned}$$

$$\begin{aligned} A^{-2} \langle \alpha_{zz}^2 \rangle &= B/4 + C/4 - (3C/4 - D^2/8) \langle \cos^2 \beta \rangle \\ &\quad - (B/4 - C + D^2/8) \langle \cos^4 \beta \rangle, \end{aligned}$$

$$\begin{aligned} A^{-2} \langle \alpha_{xx}^2 \rangle &= 1/9 + B/2 - D/9 + D^2/36 - (B - 2C - D/3 \\ &\quad + D^2/6) \langle \cos^2 \beta \rangle + (B/2 - 2C + D^2/4) \langle \cos^4 \beta \rangle, \end{aligned}$$

$$A = 1 + a + b,$$

$$B = (A^{-2}/4)[a - b + (1 - a) \sin^2 \beta_0]^2,$$

$$C = A^{-2}[(1 - a)^2 \sin^2 \beta_0 \cos^2 \beta_0],$$

$$D = A^{-1}[2 - (a + b) - 3(1 - a) \sin^2 \beta_0],$$

$$\begin{aligned} R_{1so} &= (3/4) \frac{12B + 12C + D^2}{5 + 12B + 12C + D^2} \\ &= \frac{3(a^2 + b^2 + 1 - a - b - ab)}{5(a + b + 1)^2 + 4(a^2 + b^2 + 1 - a - b - ab)}, \end{aligned}$$

β_0 is the angle between the main axis of \vec{R}' and the long axis of the molecule. In practice this usually means the angle between the bond with which the stretch vibration is associated and the long axis of the molecule.

The bond should be located in the central aromatic core of the molecule. The ordering of the axis of the bond is then more typical for the ordering of the whole molecule than is the case when it is part of the flexible alkyl chains. In practice β_0 is small and can be estimated from molecular models.

Finally the measurement of R_{1so} provides us with the functional relation between a and b . Now we have four unknown variables, namely $\langle P_2 \rangle$, $\langle P_4 \rangle$, a , and b and four independent measurements, R_1 , R_2 , R_3 , and R_{1so} . This means that the problem is determined and we can calculate the order parameters and the elements of \vec{R}' .

IV. EXPERIMENTAL RESULTS

For 5CB we only performed measurements on the 2200 cm^{-1} cyano-stretch vibration. In the case of 7OT we measured the depolarization ratios of the central acetylenic bond stretch vibration at about 2220 cm^{-1} which is very strong, well polarized, and has its axis along the main axis of the molecule. In addition, we performed measurements on the 1600 cm^{-1} symmetric stretch vibration of the two benzene rings in the molecule. This vibration also has its main axis along that of the central rigid part of the molecule (see Fig. 3). Although this vibration is quite complex it turned out to be fairly suitable for our purpose. In the case of 7CT the $\text{C}\equiv\text{C}$ and $\text{C}\equiv\text{N}$ vibration lines overlapped in the spectrum, causing a broad peak near 2220 cm^{-1} . Therefore in this case we could only perform measurements on the 1600 cm^{-1} band.

Because of multiple scattering effects the measured depolarization ratios are dependent on the thickness of the sample. This effect is linear in the sample thickness until about 50–100 μm . Therefore we performed all measurements on two sample thicknesses, 50 and 25 μm , and extrapolated to zero thickness. Because the intensity of the scattered light is very small in the case of the R_3 measurement, we had to omit the measurement on the 25 μm sample in this case due to the low signal-to-noise ratio. Fortunately, the effect of an

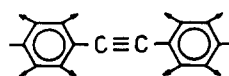

FIG. 3. Schematical drawing of the symmetrical mode of vibration in the tolane core at 1600 cm^{-1} .

error in R_3 on the order parameters is small, and is acceptable in this case, as we will show later. In addition the thickness dependence of R_3 is usually quite small.¹⁷

The measurements were done over the whole nematic range of 7OT and 7CT with 1 °C intervals. In the case of 5CB we started at 23 °C. Smooth curves were drawn through the data points. Thereafter we extrapolated the results for R_1 and R_2 to zero thickness and finally applied the correction factor C_N for the birefringence of the samples. The values for the indices of refraction were taken from the literature for 5CB⁵ and measured by ourselves for the tolanes.

Evaluation of the experimental data: $\langle P_2 \rangle$, $\langle P_4 \rangle$, a , and b were determined graphically with the help of a computer plotting program. $\langle P_2 \rangle$, $\langle P_4 \rangle$, a , and the value of R_3 calculated from R_1 , R_2 , and R_{150} were plotted against b with R_{150} and β_0 as input parameters. Where the curve representing R_3 (calculated) crosses the horizontal line R_3 (measured) we can find in the graph the value of $\langle P_2 \rangle$, $\langle P_4 \rangle$, and a at this temperature. A typical example of such a graph (7OT, C \equiv C vibration) is shown in Fig. 4.

From this figure we see that a 10% rise in R_3 (measured) gives only a 4% higher value of $\langle P_2 \rangle$ and a less than 1% lower $\langle P_4 \rangle$. We know that the actual value of R_3 is lower than the one found experimentally at nonzero thickness. As we can see in the figure this makes the situation even more favorable. Even the assumption of cylindrical symmetry of \bar{R}' , $a=b$, does not give rise to dramatic changes in the order parameters. Only when one deals with relatively high values of R_{150} , e.g., in some cases of the 1600 cm⁻¹ vibration where R_{150} is about 0.5, and consequently a and b are not very small compared to 1, it is worthwhile to measure R_3 . When R_{150} is in the range of 0.2–0.4, as is usually the case, one can safely omit the R_3 measurement. The other

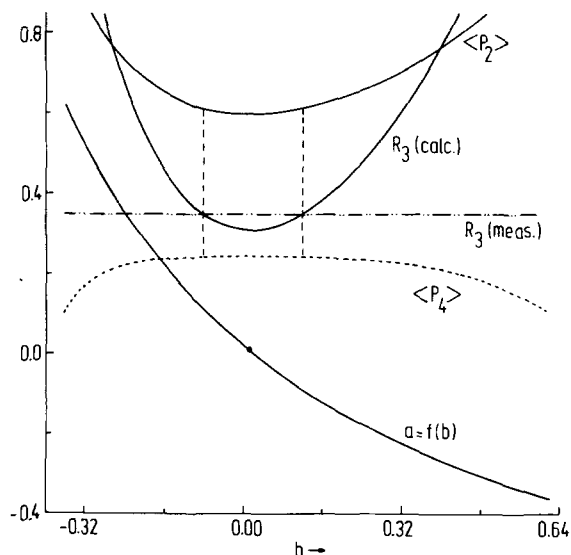

FIG. 4. Example of a plot to determine $\langle P_2 \rangle$ and $\langle P_4 \rangle$ from the measured data. See the text for details.

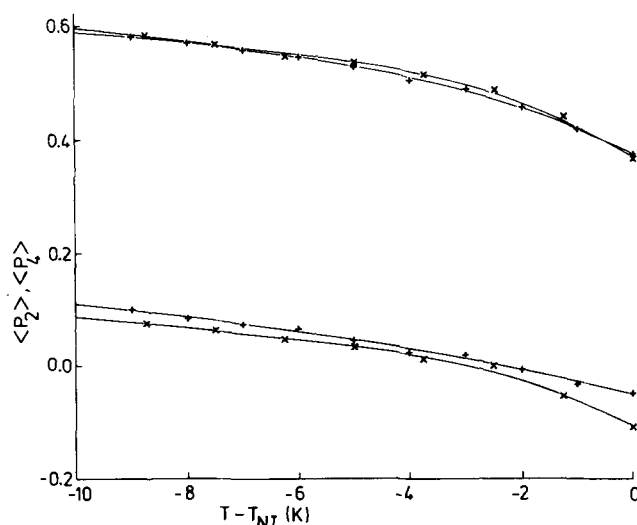

FIG. 5. Order parameters of 5CB (upper curves $\langle P_2 \rangle$, lower curves $\langle P_4 \rangle$); \times determined by Miyano (Ref. 10), $+$ this work.

way around, the method is less suitable for the determination of a and b , because of the very high sensitivity of these parameters to the input data. Therefore we do not give values for these quantities.

In all cases we assumed $\beta_0 = 0^\circ$ which seems reasonable because the vibrations have their long axes along the axes of the rigid part of the molecules. Because the graphical method is quite time consuming we also used an iterative calculational procedure on the computer to determine $\langle P_2 \rangle$ and $\langle P_4 \rangle$, which is in principle equivalent to the graphical method.

Order parameters of 5CB: In Fig. 5 we see that the results for 5CB from our own measurements are in good agreement with those published by Miyano.¹⁰ For that reason we trust these data, which seem to be the only case of results for $\langle P_4 \rangle$ obtained by different groups. It is very unfortunate that various authors have added new data for $\langle P_4 \rangle$ of various compounds to the literature, without checking whether they can reproduce existing data.

Order parameters of the tolanes: In Figs. 6–8 the measured data for R_1 , R_2 , and R_3 are given as well as the value for R_{150} for both tolanes at the different wavelength(s). In Figs. 9 and 10 the values of $\langle P_2 \rangle$ and $\langle P_4 \rangle$ are given. The values of $\langle P_2 \rangle$ obtained by diamagnetic anisotropy are included for comparison. These values are scaled to the Raman data at the lower end of the temperature scale. The agreement for 7OT is excellent. For 7CT the agreement is somewhat less good near the transition temperature. This could be due to impurity problems encountered with the $\Delta\chi$ measurements,⁴ which were also carried out in our group. For 7OT there is a small systematic difference between the values found for $\langle P_2 \rangle$ and $\langle P_4 \rangle$ with the help of the 1600 and 2220 cm⁻¹ lines. The experimental error in the order parameters is estimated to be 0.05 for $\langle P_2 \rangle$ and 0.1 for $\langle P_4 \rangle$. Nevertheless there is still a reasonable agreement between the order parameters in the case of 7OT,

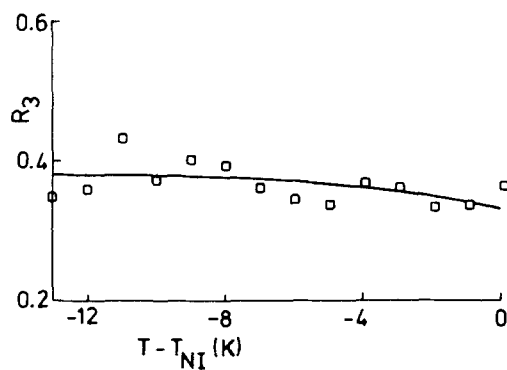
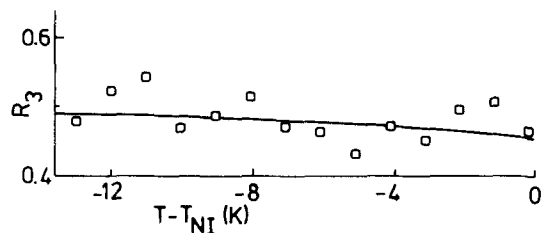
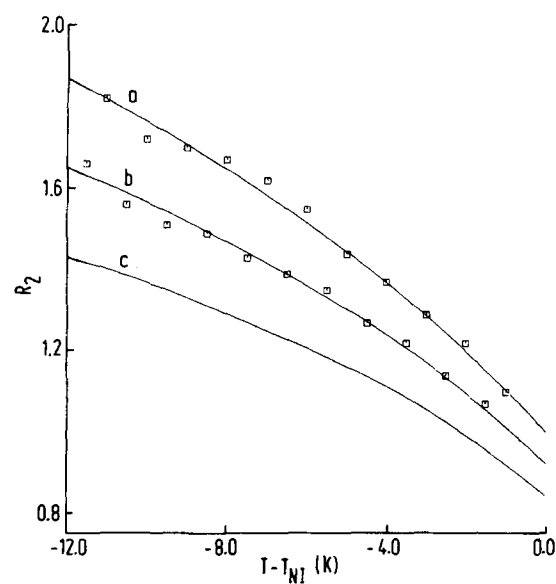
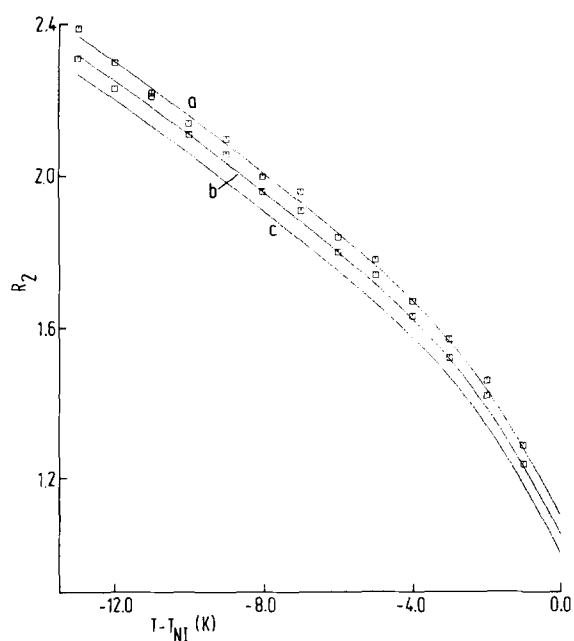
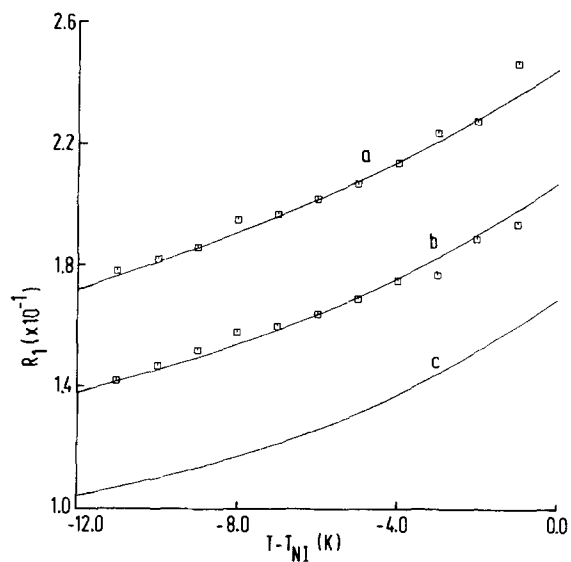
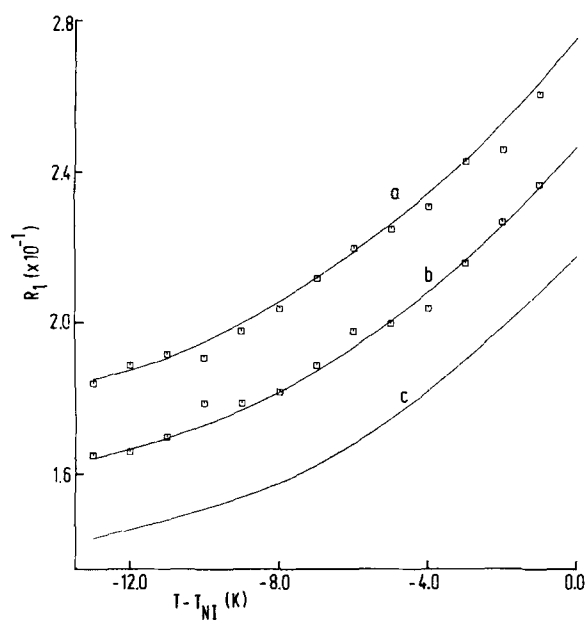

FIG. 6. Depolarization ratios of 7OT (1600 cm^{-1} band; $R_{180} = 0.395$); (a) sample thickness 50 μm , (b) sample thickness 25 μm , (c) extrapolation to zero thickness, R_3 curve only for 50 μm .

FIG. 7. Depolarization ratios of 7OT (2200 cm^{-1} band; $R_{180} = 0.340$); (a), (b), and (c) as in Fig. 6, R_3 curve for 50 μm .

and therefore we feel we can also trust the results for 7CT obtained with the 1600 cm^{-1} band only.

V. DISCUSSION

From Fig. 11 we see that the order parameters of 7OT and 7CT are very similar, but that the $\langle P_4 \rangle$ values of both tolanes differ considerably from those of 5CB.

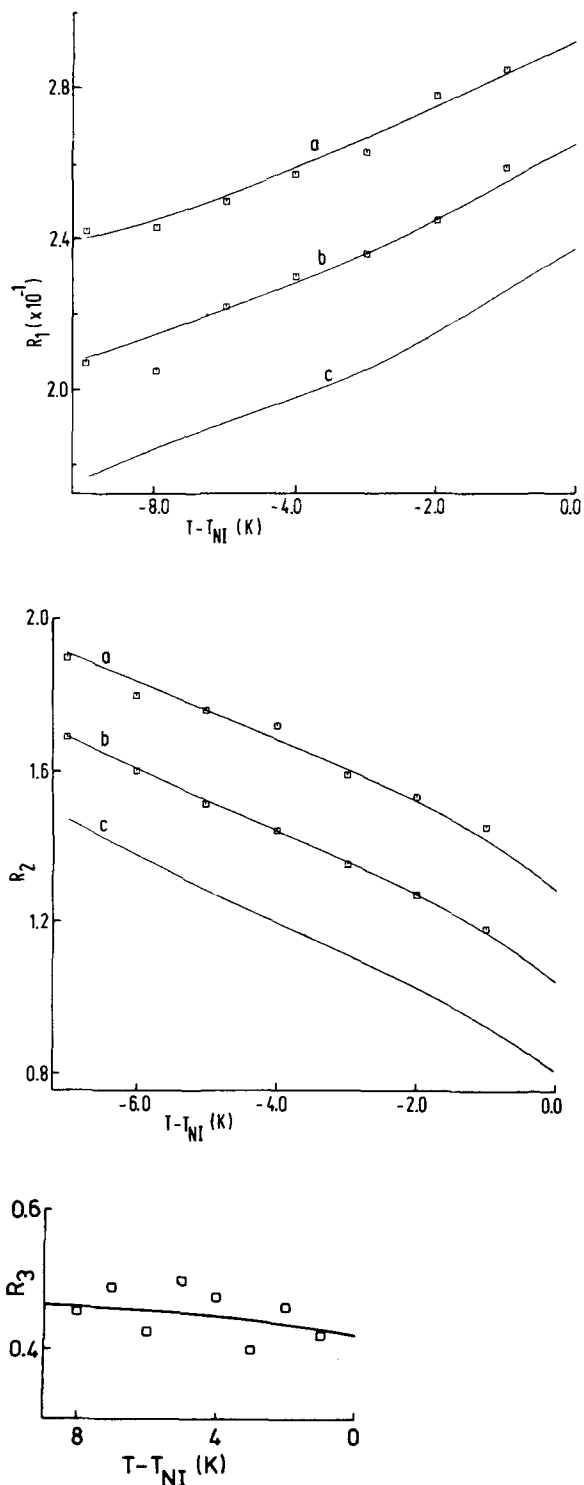

FIG. 8. Depolarization ratios of 7CT (1600 cm^{-1} ; $R_{150} = 0.405$); (a), (b), and (c) as in Fig. 6, R_3 curve for $50\text{ }\mu\text{m}$.

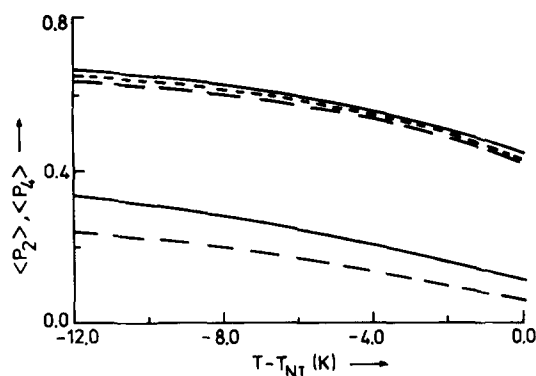

FIG. 9. Order parameters of 7OT (upper curves $\langle P_2 \rangle$, lower curve $\langle P_4 \rangle$); -2220 cm^{-1} , $--1600\text{ cm}^{-1}$, $---$ from $\Delta\chi$ measurements, see the text.

The values for $\langle P_2 \rangle$ obtained with the Raman method agree reasonably well with those from diamagnetic anisotropy. There is a small difference between $\langle P_2 \rangle$ and $\langle P_4 \rangle$ of 7OT and the measurements by Averianov¹⁸ on a similar compound with a slightly shorter alkyl chain (5OT or MOAT). We ascribe this to problems associated with the complicated setup he uses to increase the intensity of the scattered light.

From Fig. 11 we see that the order parameters of both tolanes show to good approximation mean field behavior. The values of $\langle P_4 \rangle$ predicted by the continuum theory of Faber,¹⁶

$$\langle P_4 \rangle = \langle P_2 \rangle^{10/3},$$

also fit reasonably well. The behavior of $\langle P_4 \rangle$ of 5CB can neither be described by mean field nor by Faber's theory. Interestingly, the behavior of $\langle P_4 \rangle$ of the phenylcyclohexane (PCH) series of compounds^{19,20} again agree well with theoretical predictions, although the molecular dimensions of PCH5 and 5CB are almost equal and both have a dipole of similar strength. We shall consider successively three possible causes of deviations of $\langle P_4 \rangle$ from mean field behavior: (i) molecular complexing, (ii) flexibility of the alkyl chains, (iii) internal field corrections.

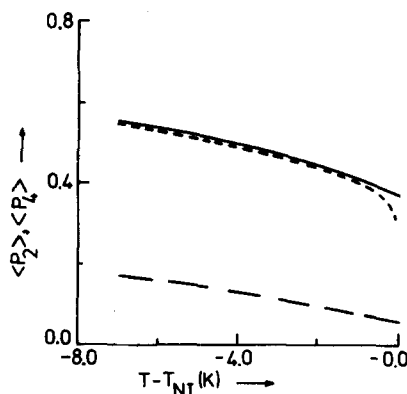

FIG. 10. $\langle P_2 \rangle$ and $\langle P_4 \rangle$ of 7CT (1600 cm^{-1}); $- \langle P_2 \rangle$, $-- \langle P_4 \rangle$, $---$ $\langle P_2 \rangle$ from $\Delta\chi$ measurements, see the text.

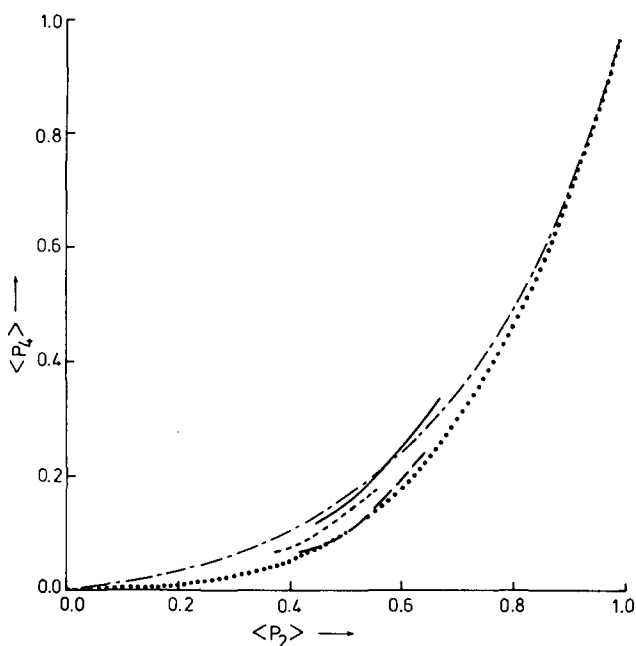

FIG. 11. Plot of $\langle P_4 \rangle$ vs $\langle P_2 \rangle$; — 7OT (220 cm^{-1}), - - 7OT (1600 cm^{-1}), - · - · 7CT (1600 cm^{-1}), - · - · - mean field theory (Maier-Saupe), · · · Faber's theory.

(i) *Molecular complexing*: The dielectric permittivity of *p*-cyano substituted compounds usually does not show the normal temperature dependence $\epsilon \sim \mu^2/T$, where μ is the permanent dipole moment.¹¹ Instead, a more or less constant ϵ is observed, which can be interpreted by anti-parallel short-range correlation of the dipoles, that becomes stronger with decreasing temperature. Formally this can be described as a monomer-dimer equilibrium.²¹ In principle one could imagine that an optimal packing of monomers and dimers in the nematic phase requires their respective long axes not to be parallel. This would lead to a broadening of $f(\beta)$, and thus to a lower value of $\langle P_4 \rangle$. Though this could explain at least qualitatively the low $\langle P_4 \rangle$ of 5CB, one would then also expect low values for $\langle P_4 \rangle$ of 7CT and of the PCH series. Although for 7CT no dielectric measurements are available, any effect of correlation would lead to order parameters different from those of 7OT, where molecular association can be expected to be much smaller. Experimentally, however, they are very similar. Hence we conclude that any possible effect of molecular association on $\langle P_4 \rangle$ must be very subtle and strongly related to the value of the equilibrium constant of the monomer-dimer equilibrium. Systematic measurements of order parameters and permittivities of series of compounds will be required to prove any effect of this type.

(ii) *Molecular flexibility*: In principle one could imagine that the flexibility of the alkyl chains has some influence on the order parameters.²² Such a relation has been suggested by Prasad *et al.*⁸ from measurements on the *n*CB series. However, their trend of decreasing $\langle P_4 \rangle$ with longer alkyl chains contradicts the results given here for 7CT and 5CB, as 5CB has the shorter chain and the lower $\langle P_4 \rangle$. Moreover such an effect can-

not explain the difference between 5CB and PCH5. In that context we note that in Ref. 8 no corrections for the effect of the sample thickness were made. Moreover, we did not succeed in reproducing the rather high values of R_{iso} given for the higher homologs of the *n*CB series. Nevertheless one should be aware of differences in molecular flexibility. Probably this can account for the small difference between the order parameters of 7OT for the 2220 and 1600 cm^{-1} band.

(iii) *Internal field corrections*: Seeliger¹⁹ has attributed the difference in $\langle P_4 \rangle$ of 5CB and PCH5 to differences in the internal field corrections, which are small in the latter case because of the low value of Δn for hydrated compounds. However, a high value of Δn does not always lead to low $\langle P_4 \rangle$ values as we can conclude from the tolanes. Moreover, we have recently measured a low $\langle P_4 \rangle$ on a mesogen with a low Δn .²³ In our opinion the differences in local field corrections are always too small to have a significant influence on the measured order parameter.

The total local field correction falls apart in two parts: (i) the anisotropy of the molecule itself and its direct environment, and (ii) the anisotropy of the medium around the molecule. The first part is not expected to change with temperature, even when going from the liquid crystalline to the isotropic phase, because of the strong correlations between neighboring molecules. Then this part of the local field is a constant and can be included in the Raman tensor. As pointed out in Ref. 7 this leads to an effective or dressed polarizability tensor. We will call this part of the microscopic part of the local field. The second part is temperature dependent via $\Delta n(T)$. It will even exist for a spherical molecule in an anisotropic (nematic) medium. In the isotropic phase it will be zero. As discussed by de Jeu and Bordewijk²⁴ this effect must be small in order to understand the experimentally found relations:

$$n_o^2 - n_e^2 \sim \Delta\chi \sim \langle P_2 \rangle$$

and

$$n_{\text{iso}} = \frac{1}{3}(2n_o + n_e)(\rho_{\text{iso}}/\rho_{\text{nem}}),$$

where ρ is the density. Any dependence of the internal field on $\Delta n(T)$ would spoil the relation between $n_o^2 - n_e^2$ and $\langle P_2 \rangle$, while that between $\Delta\chi$ and $\langle P_2 \rangle$ is not affected. So we conclude that it is a correct approximation to work with a constant dressed polarizability tensor.

The above conclusion contradicts the treatment of Averianov¹⁸ who combines both contributions to the internal field in one effective anisotropy ratio. His treatment ignores that the microscopic part of the anisotropy of the internal field also exists in the isotropic phase and is already incorporated in the *a/b* ratio of the elements of the Raman tensor as obtained from R_{iso} . Consequently the corrections he applies are too large and even spoil the agreement between the $\langle P_2 \rangle$ values from Raman and susceptibility measurements.

We conclude that at present no adequate explanation exists for the anomalously low values of $\langle P_4 \rangle$ observed for some compounds like 5CB. Contrary to our hope,

the measurements on two different tolanes do not make a conclusion possible. At present we are reinvestigating the *n*CB series in order to examine the possible influence of both molecular association and flexibility in more detail.

ACKNOWLEDGMENTS

This work was part of the research program of the "Stichting voor Fundamenteel Onderzoek der Materie" (Foundation for Fundamental Research on Matter—FOM) and was made possible by financial support from the "Nederlandse Organisatie voor Zuiver Wetenschappelijk Onderzoek" (Netherlands Organization for the Advancement of Pure Research—ZWO).

- ¹G. R. Luckhurst and G. W. Gray, *The Molecular Physics of Liquid Crystals* (Academic, London, 1979).
- ²A. J. Leadbetter and E. K. Norris, *Mol. Phys.* **38**, 669 (1979).
- ³M. Kohli, K. Otnes, R. Pynn, and T. Riste, *Z. Phys. B* **24**, 147 (1976).
- ⁴A. Buka and W. H. de Jeu, *J. Phys.* **43**, 361 (1982).
- ⁵R. G. Horn, *J. Phys.* **39**, 105 (1978).
- ⁶J. W. Emsley and G. R. Luckhurst, *Mol. Phys.* **35**, 1499 (1978).
- ⁷S. Jen, N. A. Clark, and P. S. Pershan, *J. Chem. Phys.* **66**, 4635 (1977).
- ⁸S. N. Prasad and S. Venugopalan, *J. Chem. Phys.* **75**, 3033 (1981).
- ⁹J. P. Heger, *J. Phys. Lett.* **36**, 209 (1975).
- ¹⁰K. Miyano, *J. Chem. Phys.* **69**, 4807 (1978).
- ¹¹C. Druon and J. M. Wacrenier, *J. Phys.* **38**, 47 (1977); J. P. Parneix, Thesis, Lille, 1982.
- ¹²A. J. Leadbetter, J. C. Frost, J. P. Gaughan, G. W. Gray, and M. Mosley, *J. Phys.* **40**, 375 (1979).
- ¹³P. E. Cladis, D. Guillon, F. R. Bouchet, and P. L. Finn, *Phys. Rev. A* **23**, 2594 (1981).
- ¹⁴W. H. de Jeu, *Physical Properties of Liquid Crystalline Materials* (Gordon and Breach, New York, 1980).
- ¹⁵We wish to thank Dr. H. van Sprang, Philips Research Laboratories, Eindhoven, for providing us with the paraxylene coated glass plates.
- ¹⁶T. E. Faber, *Proc. R. Soc. London A* **353**, 247 (1977).
- ¹⁷D. Langevin and M. A. Bouchiat, *J. Phys. Colloq.* **63**, C1-197 (1975).
- ¹⁸E. M. Averianov, A. Waitkiavichus, A. Y. Korets, R. Sirutkaitis, A. V. Sorokin, and V. F. Shabanov, *Zh. Eksp. Teor. Fiz.* **76**, 1791 (1979), and references therein from the same authors.
- ¹⁹R. Seeliger, Thesis, Stuttgart, 1980.
- ²⁰M. Constant and D. Decoster, *J. Chem. Phys.* **76**, 1708 (1982).
- ²¹W. H. de Jeu, *Philos. Trans. R. Soc. London A* **309**, 217 (1983).
- ²²G. R. Luckhurst and F. R. Vioria, *Mol Cryst. Liq. Cryst. Lett.* **72**, 201 (1982).
- ²³L. G. P. Dalmolen, E. Egberts, and W. H. de Jeu, *J. Phys.* (in press).
- ²⁴W. H. de Jeu and P. Bordewijk, *J. Chem. Phys.* **68**, 109 (1978).