

University of Groningen

## The protein-conducting channel SecYEG

Veenendaal, AKJ; van der Does, C; Driessen, Arnold; Veenendaal, Andreas K.J.

*Published in:*  
Biochimica et Biophysica Acta-Molecular Cell Research

*DOI:*  
[10.1016/j.bbamcr.2004.02.009](https://doi.org/10.1016/j.bbamcr.2004.02.009)

**IMPORTANT NOTE: You are advised to consult the publisher's version (publisher's PDF) if you wish to cite from it. Please check the document version below.**

*Document Version*  
Publisher's PDF, also known as Version of record

*Publication date:*  
2004

[Link to publication in University of Groningen/UMCG research database](#)

*Citation for published version (APA):*  
Veenendaal, A. K. J., van der Does, C., Driessen, A. M., & Veenendaal, A. K. J. (2004). The protein-conducting channel SecYEG. *Biochimica et Biophysica Acta-Molecular Cell Research*, 1694(1-3), 81-95.  
DOI: 10.1016/j.bbamcr.2004.02.009

### Copyright

Other than for strictly personal use, it is not permitted to download or to forward/distribute the text or part of it without the consent of the author(s) and/or copyright holder(s), unless the work is under an open content license (like Creative Commons).

### Take-down policy

If you believe that this document breaches copyright please contact us providing details, and we will remove access to the work immediately and investigate your claim.

*Downloaded from the University of Groningen/UMCG research database (Pure): <http://www.rug.nl/research/portal>. For technical reasons the number of authors shown on this cover page is limited to 10 maximum.*

Review

# The protein-conducting channel SecYEG

Andreas K.J. Veenendaal, Chris van der Does<sup>1</sup>, Arnold J.M. Driessen\*

Department of Molecular Microbiology, Groningen Biomolecular Sciences and Biotechnology Institute, University of Groningen, 9750 AA Haren, The Netherlands

Received 24 October 2003; received in revised form 30 January 2004; accepted 2 February 2004  
Available online 18 May 2004

## Abstract

In bacteria, the translocase mediates the translocation of proteins into or across the cytosolic membrane. It consists of a membrane embedded protein-conducting channel and a peripherally associated motor domain, the ATPase SecA. The channel is formed by SecYEG, a multimeric protein complex that assembles into oligomeric forms. The structure and subunit composition of this protein-conducting channel is evolutionary conserved and a similar system is found in the endoplasmic reticulum of eukaryotes and the cytoplasmic membrane of archaea. The ribosome and other membrane proteins can associate with the protein-conducting channel complex and affect its activity or functionality.

© 2004 Elsevier B.V. All rights reserved.

**Keywords:** Protein-conducting channel; Translocase; SecYEG; Protein translocation; Secretion

## 1. Introduction

All organisms consist of one or more compartments that protect their contents from diffusing or dissolving freely into the surrounding environment. These compartments are typically enclosed by a semi-permeable membranous structure that allows communication and interaction with the environment. Active transport of molecules, such as proteins, into or across the membrane is mediated by a variety of proteinaceous facilities that are residing in the membrane. The major route for the transport of precursor proteins into and across the cytosolic membrane in bacteria is commonly known as the “Sec pathway” and the participating components are termed Sec proteins [1,2]. The translocation of precursor proteins is mediated by the translocase: a multimeric protein complex that consists of a membrane-embedded protein-conducting channel and a peripherally associated ATPase (Fig. 1). The latter, called SecA [3], functions as a molecular motor to drive the protein translocation reaction.

The core of the protein-conducting channel consists of the integral membrane proteins SecY [4] and SecE [5]. They interact with SecG [6], thus forming a heterotrimeric membrane complex termed SecYEG. This complex can interact with the ribosome for co-translational membrane protein insertion [7,8], and the SecDFyajC heterotrimeric membrane protein complex [9–12] that facilitates protein translocation. The protein-conducting channel is evolutionary conserved in all kingdoms of life since homologues were also found in eukaryotes [13–19] and archaea [20–23].

## 2. Historical overview

In the early eighties, two different genetic strategies were employed to identify genes involved in the protein secretion pathway in *Escherichia coli*. One approach screened for mutations that restore the correct localization of precursor proteins with a defective signal sequence [24–26]. These dominant suppressors of signal sequence mutations were termed *prl* genes, for *protein localization*. Another approach screened for mutations that conferred conditional pleiotropic secretion defects. These mutations localized to the *sec* genes (for secretion) [3–5]. Three *prl* and *sec* genes were found to

\* Corresponding author. Tel.: +31-50-3632164; fax: +31-50-3632154.

E-mail address: [a.j.m.driessen@biol.rug.nl](mailto:a.j.m.driessen@biol.rug.nl) (A.J.M. Driessen).

<sup>1</sup> Present address: Institute of Biochemistry, Biocenter, Goethe-Universität Frankfurt, Germany.

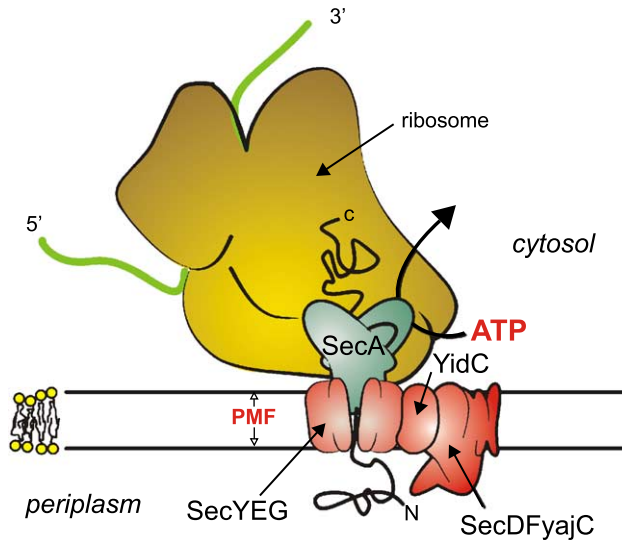

Fig. 1. Schematic representation of the preprotein translocase of *E. coli*. The cartoon shows the different units of the preprotein translocase, i.e., the motor protein SecA that drives preproteins across the membrane via a protein-conducting channel that is constituted by an oligomeric assembly of SecYEG complexes. The SecDFyajC complex is another heterotrimeric membrane protein complex that stimulates the preprotein translocation reaction by an unknown mechanism. The ribosome contacts the SecYEG complex simultaneously with the SecA protein and is involved in co-translational insertion of membrane proteins via SecYEG. YidC is involved in membrane protein insertion and it samples hydrophobic transmembrane domains that emerge from the SecYEG complex to facilitate their partitioning into the membrane. YidC forms a complex with SecDFyajC and transiently interacts with the SecYEG complex. A major share of the YidC, however, forms an independent complex in the membrane. The sizes of the proteins depicted in the cartoon do not reflect their relative sizes.

encode the same proteins: PrlA/SecY, PrlD/SecA and PrlG/SecE. All these genes are essential for viability, and their role in the protein translocation pathway was clearly established by the purification and reconstitution of the protein translocation reaction *in vitro* [27–29]. This biochemical approach identified another protein termed SecG [6], previously known as band 1 [28,30] or p12 [31]. This protein copurifies with the SecYE complex [28] and escaped genetic identification as it is not essential for protein translocation under many conditions [6,31].

The *secD* gene was identified in a screen for *E. coli* mutants that are defective in export of precursor proteins fused to  $\beta$ -galactosidase [9]. Further genetic analyses show that the *secD* locus comprises an operon together with *secF* and *yajC* [10,11]. The products of these genes form another heterotrimeric membrane complex, SecDFyajC, which interacts with the SecYEG complex [12].

YidC was identified as the *E. coli* homologue of Oxa1p, a protein that is essential for the biogenesis of some mitochondrial inner membrane proteins [32–34]. Depletion of YidC affects both Sec-dependent and Sec-independent assembly of membrane proteins in *E. coli* [35]. Biochemical studies show that YidC associates with components of the protein secretion pathway [36,37].

In summary, a heterotrimeric complex, which comprises SecY, SecE and SecG, forms the protein-conducting channel, while SecA is the motor protein that drives the translocation reaction (Fig. 1). Together, the complex of SecA with SecYEG is termed “preprotein translocase” as it suffices for protein translocation. The heterotrimeric SecD-FyajC complex and the YidC protein are translocase-associated proteins with various functions.

### 3. The translocase subunits and interacting proteins

#### 3.1. The core of the protein-conducting channel: SecY

SecY is a highly hydrophobic protein with a molecular mass of 48 kDa. The *E. coli* enzyme consists of 443 amino acid residues [38]. It is the largest membrane subunit of the protein-conducting channel and essential for viability and protein translocation. A range of computational and experimental approaches, such as hydropathy analysis, alkaline phosphatase (PhoA) fusion and proteolysis experiments, have led to a topological model in which SecY spans the membrane with 10 transmembrane segments (TMSs) and where the amino- and carboxy-terminal ends are located in the cytosol [39] (Fig. 2). SecY is ubiquitous in prokaryotes with homologues in all eukaryotes and archaea [40–42]. Sequence comparison and mutational analysis have identified conserved and essential residues in the SecY protein, and many of these mutants have been biochemically characterized. So far, dominant lethal mutations have been found only in the fifth cytosolic (C5) loop, and these mutations are thought to disrupt the SecY–SecA interaction [43,44]. Also, many of the *prlA* mutations map to conserved regions of SecY [45–54]. The mutations that inhibit the translocation of a precursor of staphylokinase overlap with *prl* mutations in TMS7 [55,56]. The positions of characterized SecY single mutations are given in Fig. 2.

#### 3.2. The core of the protein-conducting channel: SecE

SecE is a small integral membrane protein. In *E. coli*, it has a mass of 14 kDa and its 127 amino acid residues encompass three TMSs as predicted by hydropathy analysis and PhoA fusions [57] (Fig. 2). In most bacteria, SecE is a single membrane spanning protein that is homologous to the third TMS and the cytoplasmic loop 2 of *E. coli* SecE [58]. In *E. coli*, a SecE truncate that lacks the first two TMSs [59] suffices for viability and protein translocation [60], but the truncate is less stable than the wild-type SecE protein. Despite its small size and weak conservation in the membrane domain, SecE is an essential protein. The *Thermotoga maritima* [58] and *Bacillus subtilis* [61] SecE proteins can functionally complement *E. coli* SecE mutants, but growth of these cells is temperature-sensitive. Also, the single TMS chloroplast SecE homologue was found to complement

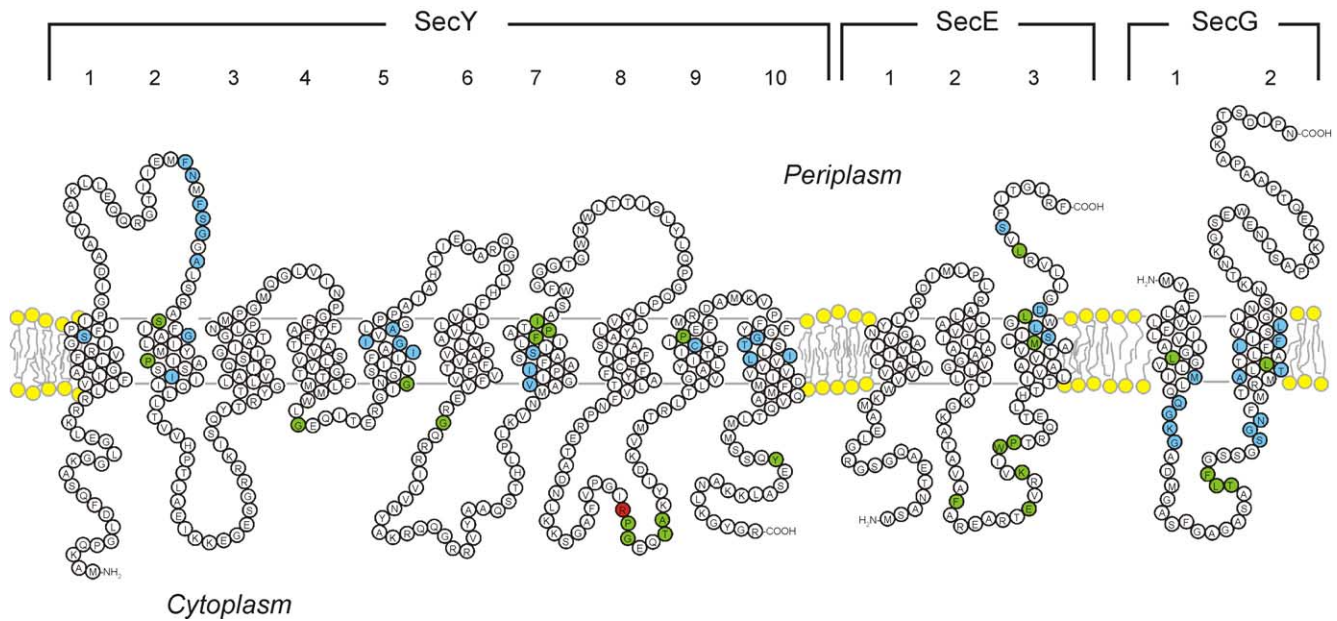

Fig. 2. Membrane topology and mutational map of *E. coli* SecYEG. The amino acid sequences of the subunits of the *E. coli* SecYEG complex are depicted in a membrane topology model with the positions of characterized single mutations indicated. The mutations are categorized into three different classes: dominant negative mutations (red), *prl* mutations (blue) and other mutations that affect cell growth and protein export (green). Positions that can exhibit more than one altered phenotype are classified according to the first appropriate class in the above mentioned list.

SecE in *E. coli* [62]. SecY and SecE are interacting proteins as will be detailed in Section 5.1.

The second cytosolic domain (C2) putatively forms an amphipathic helix structure. It contains a series of highly conserved residues but in order to inactivate SecE, multiple deletions in this region are necessary [58,63]. The third TMS is believed to function as a membrane anchoring device for the preceding conserved C2 as this TMS is only weakly conserved among SecE molecules and, albeit with severe growth and protein translocation defects, it can be replaced by unrelated TMSs [58,64]. All known *prlG* mutations, however, map to TMS3 and periplasmic loop 2 (P2) (Fig. 2). Furthermore, two mutations have been described at the periplasmic end of TMS3 of *E. coli* SecE, i.e., L111R [65] and D112P [64], that result in a partial loss-of-function. Also, Asp-112 is highly conserved. This suggests that TMS3 not only serves as an anchor to C2 but also has a more direct role in the catalytic activity of the channel.

### 3.3. SecG is a core-associated and stimulatory subunit of the channel

SecG is a loosely associated subunit of the protein-conducting channel. In *E. coli*, SecG consists of 110 amino acid residues, corresponding to a mass of 12 kDa (Fig. 2). The hydrophobicity profile of SecG reveals three hydrophobic regions [31], but PhoA fusions and proteolysis studies provide evidence for only two TMSs that are connected through a weaker hydrophobic linker that is exposed to the cytosol [66]. SecG is an intriguing protein. It is not essential for cell viability and, only in some genetic

backgrounds, deletion of SecG confers a cold-sensitive phenotype [67,68] while affecting protein export [6]. The most prominent activity of SecG is observed in vitro where it stimulates SecYE mediated protein translocation and SecA translocation ATPase activity. This stimulatory effect is in particular pronounced at low temperatures [6] or when a proton motive force (pmf) is absent [69]. A remarkable inversion of the topology of the TMSs of SecG during the SecA-mediated protein translocation cycle has been proposed. This is evidenced by an altered proteolytic degradation pattern of SecG [66] and the accessibility of the loops for chemical modification [70]. The topology of SecG has been proposed to inverse transiently upon the membrane insertion of SecA. Strikingly, even the disulfide-stabilized homodimeric form of SecG seems to undergo the same topology inversion [71]. This process is believed to facilitate membrane insertion and deinsertion of the bulky mass of SecA, a process that may be inefficient, in particular at low temperatures and decreased membrane fluidity [72,73]. Strikingly, suppressors of the cold-sensitive growth of the *secG* null strain have been isolated that map to genes involved in phospholipid biosynthesis [74,75].

As discussed previously, the *secG* gene was not identified by a genetic screen. However, more directed screens for suppressors of signal sequence defects using mutagenized *secG* libraries yielded several *prl* alleles of *secG*, termed *prlH* [76] (Fig. 2). The mutations and deletions are not confined to a particular region in the SecG protein, and most of the *prlH* mutations are relatively weak. The suppressor activity of some of the PrlH mutants is equal to the strongest PrlG mutants of SecE. Another screening method using



toxic chimerical precursors has yielded many *sec* mutations in the *secG* gene. These mutations display a weak phenotype and are dispersed in SecG with the exception of the periplasmic domains. Many of the mutations are concentrated in the so-called TLF domain in the cytosolic loop that consists of Thr-41, Leu-42 and Phe-43 [67,77].

### 3.4. SecA- the ATPase that drives protein translocation

Although not a permanently associated component of the protein-conducting channel, the SecA ATPase is the motor that drives the translocation reaction. The structure, function and mechanism of SecA are extensively described by Economou in this series (see Chapter 5 in this issue). Therefore, this section focuses on the ability of SecA to interact with the SecYEG complex.

*E. coli* SecA is a large protein of 102 kDa and consists of 901 amino acid residues. It is present in the cell in a soluble as well as membrane-associated state [78]. Cytosolic SecA is mainly present as a homodimer [79–81]. At the membrane, SecA binds with low affinity to negatively charged phospholipids and with high affinity to the SecYEG complex [82]. The binding of SecA to the SecYEG complex, thus forming the translocase, activates SecA for the high affinity interaction with preprotein-bound SecB [82]. Transfer of the preprotein from SecB to SecA occurs through a number of defined steps. Binding of the signal sequence to SecA strengthens the SecA–SecB interaction and dislocates the mature preprotein domain from SecB [83]. SecB is released by SecA upon the ATP-dependent initiation of translocation [84]. Both the signal sequence and the mature domain of the preprotein can interact with SecA [85]. The preprotein is translocated through the protein-conducting channel by a process that involves multiple cycles of ATP binding and hydrolysis by SecA [86,87]. Recently, the crystal structures of the SecA protein of *B. subtilis* [88] and *Mycobacterium tuberculosis* [89] have been determined to atomic resolution, revealing the sites of interaction with nucleotides and the Mg<sup>2+</sup> cofactor. *Prl* mutations in the *secA* gene, termed *prlD*, are found throughout the gene sequence. Many *prlD* mutations match to *azi* mutations in SecA that confer resistance to sodium azide [90,91]. An altered conformation at lower temperatures, reduced affinity for ADP and an elevated turnover rate are characteristic for SecA proteins harboring either a *prlD* or *azi* mutation [92]. Thus, it seems that an increased SecA ATPase activity is the underlying cause for suppression of signal sequence defects (and azide resistance).

### 3.5. The accessory membrane complex SecDFyajC

SecD, SecF and YajC are accessory proteins that form another heterotrimeric complex that can interact with the SecYEG complex [12]. While the other *sec* genes are dispersed on the chromosome, the genes encoding SecD, SecF and YajC together constitute an operon [10,11]. In *E. coli*, SecD and SecF are integral membrane proteins with a

molecular mass of 67 and 35 kDa, respectively. They each contain six predicted TMSs and a large periplasmic domain, in particular SecD. In some bacteria, e.g. *B. subtilis*, SecD and SecF are fused together, forming a single membrane protein with 12 putative TMSs that is appropriately termed SecDF [93]. SecD and SecF belong to the Resistance-Nodulation-Cell Division (RND) superfamily of transporters and homologues have been found in archaea, but not in eukaryotes [94]. This suggests a transporter function for the SecDF complex, for instance the removal of cleaved signal peptides or the clearance of the translocation channel. However, such an activity has remained undiscovered. YajC is a smaller protein with a molecular mass of 12 kDa in *E. coli*. It comprises a single TMS and a large cytosolic domain.

SecDFyajC is not required to reconstitute protein translocation *in vitro* for which SecA and the SecYE complex suffices. A stimulatory effect on the *in vitro* translocation activity has been observed only in the absence of SecG [12,95]. In contrast, viability and protein export *in vivo* are severely affected when cells are lacking SecD or SecF [96]. Mutations and deletions in YajC have no effect on cell growth or protein export [11]. Studies on SecDFyajC suggest an involvement of the complex in different steps, such as regulation of the catalytic cycle of SecA [12,97,98], release of translocated proteins from the membrane [99] and in mediating the interaction between SecYEG and YidC [37] (see Section 5.5). However, the exact role of the SecDFyajC complex in the protein translocation pathway remains to be solved.

### 3.6. YidC is involved in the assembly of membrane proteins

YidC is a large integral membrane protein with a mass of 62 kDa in *E. coli* that is involved in the biogenesis of both Sec-dependent and Sec-independent membrane proteins. Topology analysis of YidC suggests six TMSs and the presence of a large periplasmic domain [100]. YidC interacts with Sec-dependent membrane proteins during their membrane insertion [36] and can be found associated with the SecDFyajC complex [37]. Depletion of YidC has a strong effect on the membrane insertion of Sec-independent phage proteins [35] and only mildly affects the biogenesis of several Sec-dependent membrane proteins [101]. It, however, severely affects the biogenesis of subunits of the major energy-transducing complexes such as the F<sub>0</sub> domain of the F<sub>1</sub>F<sub>0</sub> ATPase and cytochrome *o* oxidase [102,103], thus defecting respiratory. This explains why the YidC protein is essential for viability.

## 4. Conservation of the core domain of the protein-conducting channel

The protein-conducting channel is well conserved in prokaryotes, eukaryotes and archaea. In the eukaryotic

endoplasmic reticulum (ER), it consists of the trimeric Sec61p complex that mediates co- and posttranslational protein translocation into or across the membrane of the ER. The subunits of the mammalian Sec61p complex are Sec61 $\alpha$ , Sec61 $\beta$  and Sec61 $\gamma$ . The Sec61p complex is homologous to SecYEG and the Sec61 $\alpha$  and Sec61 $\gamma$  subunits are the counterparts of SecY and SecE, respectively [13]. Sec61 $\beta$  and SecE are not homologous and are probably functionally distinct. Sec61 $\beta$  has recently been shown to function as a guanine nucleotide exchange factor for the  $\beta$ -subunit of the signal recognition particle receptor [104] (see also Chapter 1 in this issue) while SecE seems to function as an attenuator of the SecA catalytic cycle. The ER of the yeast *Saccharomyces cerevisiae* contains two homologous trimeric complexes, Sec61p and Ssh1p [105]. The yeast Sec61p complex consists of Sec61p, Sbh1p and Sss1p, which is the yeast nomenclature of Sec61 $\alpha$ , Sec61 $\beta$  and Sec61 $\gamma$ , respectively. Sss1p (Sec61 $\gamma$ ) also participates in the Ssh1p complex together with the subunits Ssh1p and Sbh2p, the homologues of Sec61p (Sec61 $\alpha$ ) and Sbh1p (Sec61 $\beta$ ). In contrast to the Sec61p complex, the Ssh1p complex is not essential and has been implicated in co-translational protein translocation only [105–107]. Homologues of the protein-conducting channel subunits SecY and SecE have also been found in the thylakoid membrane of chloroplasts. Together with SecA, this complex mediates the translocation of preproteins across the thylakoid membrane [14–19]. Homologues of SecY have also been identified in plastids of cyanelles [108–110], cyanobacteria [14] and even in the mitochondria of *Malawimonas jakobiformis*, an ancient jakobid protist [111]. In archaea, genes encoding Sec61 $\alpha$  (SecY), Sec61 $\gamma$  (SecE) and Sec61 $\beta$  (SecG) have been identified [20–23]. These subunits are more homologous to the eukaryotic than to the bacterial counterparts [42].

## 5. The channel complex - subunit organization

### 5.1. Biochemical studies on the interactions within the core of the channel

The interactions between the subunits of the protein-conducting channel have been studied in considerable detail both genetically and biochemically, and more recently structurally. SecY forms a stoichiometric complex with SecE. In the absence of SecE, SecY is unstable and is readily degraded by the membrane-bound protease FtsH [112]. Uncomplexed SecY seems to be toxic to cells as the accumulation of SecY in conditionally lethal FtsH mutants results in hampered cell growth and protein export [112]. Preformed SecYE complexes do not seem to dissociate in vivo as no exchange of SecE subunits between the complexes has been observed [113,114]. Only the carboxy-terminal part of *E. coli* SecE, encompassing the third TMS and C2 loop, is required for the

SecY interaction [60], which is in line with the observation that in most bacteria, SecE consists of this domain alone. Biochemically, the *B. subtilis* SecE has been shown to interact with the *E. coli* SecY protein and vice versa, but such hetero-complexes are largely inactive for protein translocation [115].

Evidence for interacting domains between SecY and SecE has been found in all three cellular compartments, i.e. cytosol, inner membrane and periplasmic space. In the cytosol, the C4 loop of SecY is thought to interact with SecE. A dominant negative SecY mutation (*secY<sup>d1</sup>* in loop C5), which results in sequestration of SecE into an inactive complex, can be suppressed by second site deletion/insertion mutations in the C4-TMS7 region of SecY. Most of these mutations cluster in the C4 loop [116] and may disrupt the binding of SecY to SecE, which would overcome the dominant *secY<sup>d1</sup>* mutation by releasing the SecE for complex formation with functional SecY. Indeed, mutant SecY24, harboring a temperature-sensitive mutation in C4, has lost its ability to co-immunoprecipitate with SecE [116]. The *secY24* mutation does not affect co-purification of SecY with SecG, hence the C4 loop seems to interact specifically with SecE [117]. In addition, mutations in the conserved loop C2 and the *prlG* mutations in TMS3 of SecE also affect SecYE complex formation [64,118]. These results suggest possible sites of interaction between loops C4 and C5 of SecY and C2 (and TMS3) of SecE. Such interaction could be biochemically demonstrated by cysteine-directed cross-linking that provides distance information of proximal residues in neighboring proteins. Bifunctional cross-linkers can mediate the formation of a cross-link between a cysteine residue and a proximal lysine or another cysteine residue. Also, under oxidizing conditions, a disulfide bond can be formed between proximal cysteine residues within 4–6-Å distance [119,120]. An overview of cross-links between the domains of the protein-conducting channel is given in Fig. 3. Using cysteine cross-linking, sites of contact between C4 of SecY and C2 of SecE were demonstrated biochemically [121]. The same positions in C2 of SecE also contacted several positions in loop C5 of SecY [121]. Cross-linking was inhibited after the introduction of the *secY24* (in C4 of SecY) or *prlG* mutations in TMS3 of SecE [121], confirming the earlier co-immunoprecipitation results [64,116].

Sites of interaction between SecY and SecE at the periplasmic face of the membrane and interhelical contacts were postulated based on synthetic lethality of certain allelic combinations of *prlA* (SecY) and *prlG* (SecE). Lethality was induced in pairwise combinations of mutation F67C (*prlA3*) and S68P (*prlA726*) in loop P1 of SecY with S120F (*prlG3*) in loop P2 of SecE. Similarly, combinations of I278N (*prlA208*) in TMS7 and L407R (*prlA301*) and I408N (part of *prlA4*) in TMS10 of SecY with L108R (*prlG1*) in TMS3 of SecE are lethal [122]. Cysteine scanning mutagenesis has provided evidence for a close proximity of the P1 loop of SecY to the P2 loop of SecE, at cysteine-substituted positions of the lethal *prl* combination [123]. The same

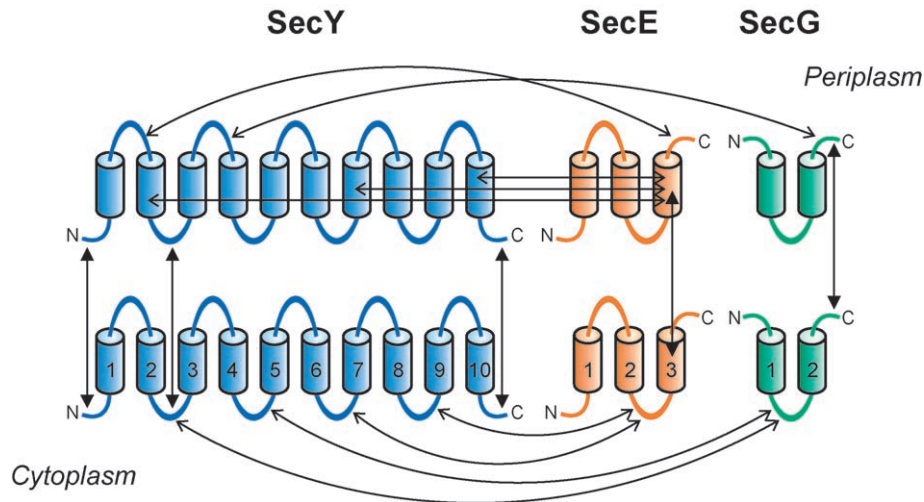

Fig. 3. Interactions between subunits of the protein-conducting channel. Sites of interaction between the SecYEG subunits as identified by chemical cross-linking of neighboring cysteine residues or cysteine and lysine residues. Interacting domains within and between SecYEG complexes are indicated by a connecting line with arrows in this schematic representation of the SecYEG topological model.

method has identified contact between TMS3 of SecE and multiple sites on TMS2, TMS7 and TMS10 of SecY, although the interaction with TMS2 appeared rather weak. The periodicity of the appearing cross-links between TMS3 of SecE and TMS7 and TMS10 of SecY confirms the  $\alpha$ -helical nature of these transmembrane segments [124–126]. Importantly, cysteine scanning mutagenesis experiments have provided strong evidence that SecE molecules of neighboring SecYEG complexes are in close proximity. A three-dimensional model of, seemingly, the core of the protein-conducting channel could be constructed based on the identified cross-links. This model shows the essential TMS3 of SecE in contact with TMS2, TMS7 and TMS10 of SecY at one side of its helical structure. The other face of the helix contacts a neighboring TMS3 of SecE at the dimer interface of two SecYEG complexes [124–126]. The model suggests that TMS3 of SecE is strongly tilted relative to the helices of SecY and to the opposing SecE helix [126]. This arrangement and the localization of SecE at the SecYEG dimer interface was recently confirmed by structural studies [127,128] (see Section 6.3).

### 5.2. SecY is the interacting partner for secG

The SecY protein also interacts with SecG. Even in the absence of SecE, SecG co-purifies with SecY [117]. SecG weakly increases the stability of SecY [129] and the SecYE complex [117]. Cross-linking studies demonstrated that the cytosolic loops C2 and C3 of SecY are in close proximity to the cytosolic loop of SecG [130,131] and that the periplasmic loop P2 of SecY is proximal to the carboxy-terminal end of SecG [131]. SecG and SecE do not seem to interact, although one report showed that SecG stabilizes a carboxy-terminal truncate of SecE [129]. SecG failed to co-purify

with SecE in a *secY24* background in which the interaction between SecY and SecE is disturbed [117]. Taken together, these data indicate that SecY interacts at independent sites with SecE and SecG.

### 5.3. SecA interaction with the channel subunits

SecA binds the SecYEG or SecYE complex with high affinity, and this event activates SecA for preprotein-stimulated ATPase activity [132]. The binding reaction itself, i.e., in the absence of preprotein, regulates the rate of nucleotide exchange on SecA [133]. This step precedes the preprotein-dependent initiation of translocation, and serves to activate SecA for preprotein-stimulated ATPase activity. SecA can be cross-linked in vivo to SecY [134]. Ligand affinity blotting revealed that SecA binds to a SecY truncate that harbors the first 107 amino acids of SecY. This fragment corresponds to the C1, TMS1, P1, TMS2 and C2 domains of SecY [135]. However, mutations that affect the SecA–SecY interaction have been mapped only to C5 and C6 of SecY [44,136,137]. These SecY loops are poorly conserved in the archaeal and eukaryotic Sec61 $\alpha$  families. Indeed, archaea and eukaryotes lack a SecA homologue. SecY likely contains multiple SecA interacting sites, while SecE does not seem to interact with SecA. SecA could, however, be cross-linked to SecG under translocation conditions [66,70]. A SecA truncate that lacks eight amino acid residues at the amino-terminus is unable to form the translocation-associated stable SecA proteolytic fragments and did not elicit the SecG topology inversion [138]. This suggests that SecA and SecG interact during the translocation reaction, while SecG is not essential for the high affinity binding of SecA to the channel complex [12,139,140].

#### 5.4. The SecDFyajC complex associates with the SecY subunit

Co-immunoprecipitation studies demonstrated that SecYEG associates with another heterotrimeric complex, SecDFyajC [12]. Overproduction of SecF or YajC has a stabilizing effect on SecY [113,141]. Furthermore, a dominant-negative mutation, *secY<sup>d1</sup>*, is suppressed by the overproduction of YajC [142]. These results indicate that it is the SecY subunit that interacts with both the SecF and YajC subunit. The SecDFyajC complex also readily co-immunoprecipitates with the SecYE complex, suggesting that SecG is dispensable for the association between both complexes [12]. However, a recent study indicated that depletion of SecDFyajC results in a decreased expression of SecG while it inhibited the disulfide bond formation between two SecG subunits harboring a cysteine mutation [95].

#### 5.5. YidC can be found in close proximity to the translocase

YidC can be cross-linked to nascent membrane proteins during the co-translational translocation reaction, suggesting close proximity of YidC to the translocase [36,101,143–146]. YidC co-purifies with overproduced levels of SecYEG, in particular when SecDFyajC was overproduced as well [36]. Indeed, a condition was reported in which YidC only co-purifies with wild-type and overproduced levels of SecDFyajC and not with SecYEG, suggesting that the functional interaction between SecYEG and YidC is mediated via SecDFyajC [37].

#### 5.6. Ribosome binding to the channel

The ribosome associates with the protein-conducting channel in both the eukaryotic and bacterial co-translational protein translocation [7,8,147–149]. Electron microscopy revealed that the peptide exit tunnel of the large ribosomal subunit aligns with the pore of the eukaryotic Sec61p complex, thus resulting in a tight seal between the ribosome and the channel [149–151]. In vitro studies using purified ribosome–Sec61p complexes showed that the preprotein is needed to form the tightly sealed contact [152]. Recently, the ribosome and SecA were reported to bind simultaneously to the SecYEG complex, while the ATP-dependent SecA membrane insertion is accompanied by the dislocation of the ribosome from the translocation site [8]. Because of space considerations, it is difficult to envisage how SecA and the ribosome can bind simultaneously to the SecYEG complex.

#### 5.7. Channel interaction with the translocating preprotein

The environment of a preprotein while it passes the translocation channel has been analyzed by various methods. Translocation-arrested preprotein intermediates were used to identify interacting partners via a cross-linking

approach. These intermediates were generated by fusing proOmpA, a preprotein in *E. coli*, to dihydrofolate reductase (DHFR), an enzyme that stably folds in the presence of its co-factors NADPH and methotrexate. The stable folding of the DHFR moiety results in the jamming of the protein-conducting channel. In this way, proOmpA was found to cross-link to SecA and SecY but not to SecE, SecG, SecD or SecF [153]. In mammalian endoplasmic reticulum-derived microsomes, the molecular environment of a nascent preprotein was analyzed by fluorescent techniques. These data suggested that the pore provides an aqueous environment to the translocating preprotein [154]. In *S. cerevisiae*, the interaction between the signal sequence of prepro- $\alpha$ -factor and the Sec61p complex of the ER has been studied. The signal sequence could be cross-linked to TMS2 and TMS7 of Sec61 $\alpha$  [155], while no cross-links were observed between the signal sequence and Sss1p or Sbh1p. Surprisingly, the signal sequence could also be cross-linked to phospholipids and thus appears to be surrounded both by the channel protein and lipid environment. A model for the initiation of translocation was proposed in which Sss1p/SecE functions as a surrogate signal sequence in the closed form of the Sec61p/SecY channel and is displaced by the signal sequence of a preprotein upon its binding. This model is based (partially) on overlapping regions of cross-linking for Sss1p and the signal sequence to Sec61p [156] and the similarity between Sss1p/SecE and a signal sequence. Indeed, cysteine-directed cross-linking confirms that the essential TMS3 of *E. coli* SecE contacts TMS2 and TMS7 of SecY, but a complete displacement of SecE by the signal sequence seems unlikely since the cross-links could also be formed when preprotein translocation was initiated [124,125].

## 6. Channel structure and dynamics

### 6.1. The dimensions and oligomeric nature of the channel

Insight into the structure and dynamics of the protein-conducting channel is important to understand the mechanism of preprotein translocation. Electron microscopy of purified mammalian and yeast Sec61p complexes displayed ring-like particles with a diameter of  $\sim 85$  Å and a central pore or indentation of  $\sim 20$  Å [149–151,157]. The particles have a quasi-pentagonal symmetry and consist of an oligomeric assembly of three to four Sec61p complexes. The assembly of reconstituted Sec61p oligomers is stimulated by the association of ribosomes or the Sec62/63p complex, which are ligands for the co- and posttranslational translocation, respectively [157]. A three-dimensional reconstruction of the yeast ribosome–Sec61p complex showed that the central cavity in the Sec61 oligomer aligns with the exit of a tunnel that traverses the large ribosomal subunit [149]. Nascent chains are thought to emerge from



this tunnel, so this suggests an alignment of the conduits in co-translational protein translocation [149]. The SecYE complex, purified from *B. subtilis*, forms structures similar in size and shape to the Sec61p oligomers, although in the electron microscopic study only a small amount of quasi-pentagonal shapes was observed. The mass density of the ring structure suggests three or four copies of SecYE. This would imply that SecY and SecE are sufficient to form the ring even in the absence of SecG, and would be consistent with the fact that SecG is not essential for the protein translocation activity [158]. In contrast to the eukaryotic Sec61p that either needs ribosomes or the Sec62/63p complex to reconstitute oligomers in membranes, SecA or other translocation ligands were not required for the formation of these SecYE oligomers [159]. The *E. coli* SecYEG complex has also been studied by electron microscopy and mass analysis. Purified samples containing SecYEG revealed elongated particles of  $\sim 85$  by  $\sim 65$  Å with an undefined central indentation of  $\sim 20$  Å. The size and mass of these particles reflect a dimeric form of SecYEG [160]. A fraction of the particles was of smaller size and represented monomeric SecYEG complexes. Additionally, SecYEG was purified from translocation-active or -arrested intermediates that were induced by the addition of SecA, proOmpA and ATP (or AMP-PNP). A significant population of larger particles was observed, having a diameter of  $\sim 105$  Å and a central cavity of 50 Å. Their size and mass correspond to a tetrameric form of SecYEG [160]. Particles with an even higher density were observed in these samples, which are probably tetramers of SecYEG with the SecA protein associated with the channel. This study suggests that dimers of SecYEG are assembled into tetrameric structures upon the initiation of translocation to form the protein-conducting channel.

The existence of oligomeric forms of the SecYEG complex has also been shown in various biochemical studies. Analytical ultracentrifugation experiments assessing the oligomeric state of *E. coli* SecYEG in detergent solution showed mainly monomers and tetramers. Interestingly, a shift to dimeric forms was observed when SecYEG harbors the PrlA4 mutant of SecY [161]. A blue native gel analysis of *E. coli* SecYEG in detergent solution shows equilibrium of monomeric and dimeric species [162]. SecYEG was found to be present as a dimer in translocation intermediates that harbor a trapped preprotein but in the absence of SecA. Strikingly, SecG seemed to induce the formation of tetrameric forms of SecYEG. Fluorescence resonance energy transfer (FRET) experiments demonstrated that SecYE of *Thermus thermophilus* is present at least as dimers when purified SecYE complexes were reconstituted into membranes [163]. A covalent link between two SecY subunits resulted in a SecYEG dimer that was able to bind SecA and is active in protein translocation [164]. Cysteine scanning mutagenesis revealed multiple sites of contact between two neighboring SecE subunits in the SecYEG complex [124,125]. Cross-linking analysis also showed that the

cytosolic domain C2 and both terminal ends (C1 and C6) of two neighboring SecY subunits are proximal [130]. Finally, cysteine cross-links were observed between two neighboring SecG subunits when cysteine residues were introduced into the periplasmic located carboxy-terminus [71] (Fig. 3).

One study proposes that the active channel harbors only a single copy of the complex since SecYEG oligomers could not be detected by chemical cross-linking [165]. It was argued that the oligomeric forms of SecYEG observed in other studies are aggregates that result from the overproduction or purification of SecYEG. However, chemical cross-linkers seem to disrupt the SecYEG oligomerization [162] presumably by interference with ionic interactions that stabilize the SecYEG oligomers. Mutational analysis of the conserved C2 domain of SecE suggests that mutant SecE molecules obtain a dominant negative phenotype by the sequestration of wild-type SecE, indicating the presence of SecYEG oligomers in vivo [63]. Moreover, SecYEG dimers were detected in inner membrane vesicles harboring near wild-type levels of SecYEG in a cysteine scanning mutagenesis approach [125]. Considering these observations, together with the vast amount of data that show the existence of SecYEG oligomers, it is clear that SecYEG exists as oligomeric species. It, however, remains an unresolved question as to whether SecYEG functions as a monomer or oligomer (see also Section 6.3).

## 6.2. Both the *pmf* and *prlA* mutations affect the channel dynamics

Preproteins are translocated across the membrane by repeated cycles of SecA insertion and deinsertion at the expense of ATP. The translocation reaction, once initiated by SecA, is stimulated by the pmf and can be continued and completed when ATP is depleted [86,166]. The presence of a pmf can restore the translocation of a preprotein harboring an internal cysteine cross-linked loop that otherwise blocks the channel and accumulates into a translocation intermediate [167,168]. This suggests that the pmf contributes to the gating of the channel in a more relaxed fashion than SecA does. Similarly, *prlA* mutations in SecY relieve the steric blockage of the channel by preproteins (harboring an internal loop, stably folded moiety or large molecular probe) and thus alleviate the pmf-dependency of their translocation [169,170]. *PrlA* and *prlG* mutations are thought to result in a relaxation of the interaction between the SecY and SecE subunits [118,171] and this may be reflected in the gating properties of the channel. Some *prlA* mutations result in a channel complex with a higher affinity for SecA and an increased translocation rate of wild-type preproteins [54,172,173]. One explanation for these observations is the reduction of the rejection rate of preproteins upon the initiation of translocation by stabilizing SecA at the channel complex [54]. The latter may be the reason for the observed shift from monomers to dimers of SecYEG in detergent

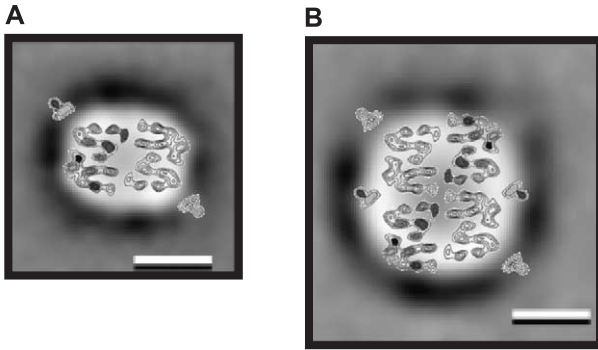

Fig. 4. Overlay of the SecYEG dimer structure with SecYEG oligomers as visualized by electron microscopy. The medium-resolution structure of the SecYEG dimer is superimposed on the electron microscopic image of SecYEG dimer (A) and tetramer (B) particles, once their scales were corrected in relation to each other. This reveals that both the outer dimensions and the size of the cavity within the structures are comparable. Two SecYEG dimers fit readily into the tetramer image of SecYEG. The medium-resolution structure of the SecYEG dimer, derived from two-dimensional crystals, represents a horizontal cross section of the complex in the plane of the membrane, with the top view facing the cytosol [127]. The electron microscopic images of detergent-solubilized SecYEG were visualized by negative staining [160]. Scale bar = 50 Å.

solution when the complex harbors a PrlA4 instead of wild-type SecY (see above) [161].

### 6.3. Structural analysis of the SecYEG complex

In recent years, medium- and high-resolution structural data have been obtained on the SecYEG complex. A projection structure at 9-Å resolution was derived from electron microscopy of two-dimensional crystals of *E. coli* SecYEG, showing undefined regions of dense mass within the SecYEG complex [161]. A three-dimensional reconstruction at a resolution of 8 Å was produced from tilts of the two-dimensional SecYEG crystals. This medium-resolution map shows a SecYEG dimer in which each monomer

contains 15 distinct mass densities that likely correspond to the combined TMSs of the SecYEG complex [127]. With the availability of the crystal structure of the Sec61 $\alpha\gamma\beta$  complex from the archaeon *Methanococcus jannaschii* [128] (see also below), it is now possible to assign these densities to specific TMSs. The distinct tilted helices at the dimer interface represent the TMS3 of two neighboring SecE proteins as suggested by the cysteine scanning studies [124–126]. The dimensions of the SecYEG dimer from the crystal structure [161] and the extrapolated tetramer are comparable to those observed for the SecYEG dimers and tetramers in the electron microscopy studies [160] (Fig. 4). The tetramer consists of two dimers. Therefore, formation of a central channel will require a major subunit reorientation. The map of the SecYEG dimer reveals an opening at the dimer interface at the cytosolic side of the membrane. The diameter of this cavity is also comparable to that observed for the SecYEG dimers in the electron microscopy studies (Fig. 4A). Since the cavity is closed at the periplasmic side of the membrane, it has been proposed that the reconstituted SecYEG dimer structure represents the translocation-closed state. According to this hypothesis, conversion to the active and opened state would require a rearrangement of the two SecE helices at the dimer interface. However, this hypothesis is unlikely as the cross-links between the two TMS3 of SecE persist during preprotein translocation [124,125]. Channel formation may also be induced by the assembly of two SecYEG dimers into a tetrameric complex, which does not necessarily require the displacement of TMS3 of SecE. Alternatively, the cavity may represent part of the SecA binding site and the preprotein is translocated along the interface of two SecYEG dimers.

Recently, the crystal structure of Sec61 $\alpha\gamma\beta$  complex from the archaeon *M. jannaschii* was elucidated [128] (Fig. 5). The 2.3-Å resolution structure revealed a monomeric Sec61 $\alpha\gamma\beta$  complex with a barrel-like arrangement of the 10 TMSs of Sec61 $\alpha$  (SecY) and a steeply angled Sec61 $\gamma$

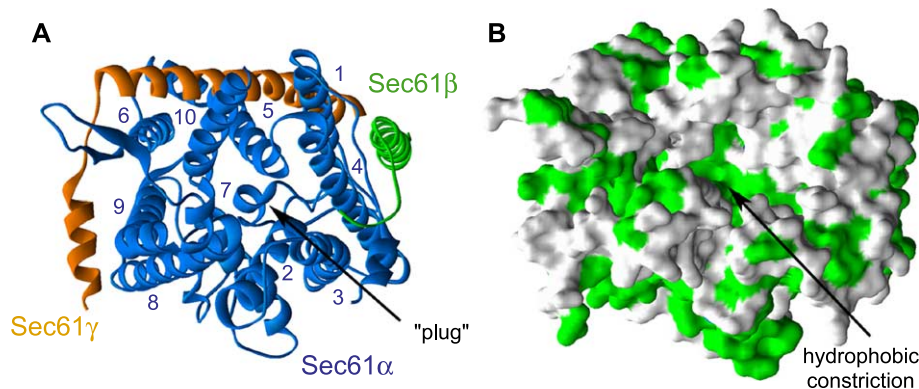

Fig. 5. Crystal structure of the Sec61 $\alpha\gamma\beta$  complex of *M. jannaschii*. (A) Top view (cytosolic face) showing a ribbon drawing of the Sec61 $\alpha\gamma\beta$  complex (based on the coordinates deposited to the Protein Data Bank as 1RHZ). The Sec61 $\alpha$  (SecY), Sec61 $\beta$  (SecG) and Sec61 $\gamma$  (SecE) subunits are colored in blue, green and orange, respectively. The barrel-like arrangement of the transmembrane segments of Sec61 $\alpha$  seems to accommodate a central pore-like structure that is sealed on the external face of the membrane by a re-entrance loop formed by external loop 1. (B) Solvent-accessible surface of the Sec61 $\alpha\gamma\beta$  complex shown in the orientation as in A. The hydrophobic residues are indicated in green showing the putative central pore that is sealed by a hydrophobic constriction. (For color see online version).

(SecE) transmembrane helix that forms a girdle around part of the Sec61 $\alpha$  barrel. Sec61 $\beta$  (SecG) is peripherally associated with Sec61 $\alpha$ . This arrangement of subunits can be superimposed on the densities of the projection structure of the *E. coli* SecYEG [161]. The crystal structure has led the authors to propose that the monomeric SecYEG complex may accommodate a protein-conducting channel that would run through the centre of the SecY monomer (Fig. 5). This putative channel is partially occluded by a “plug” formed by an external loop region between TMS1 and TMS2 and has a “seal” near its centre where several hydrophobic amino acids come together (Fig. 5B).

The structure explains many observations while it is in variance with others. It was proposed that the unusual crossed organization of SecY TMS2 and TMS7 could form a lateral opening through which signal peptides insert laterally into the translocase and transmembrane segments of integral membrane proteins escape from the lumen of the channel into the lipids of the membrane. The stabilizing effect of SecE on SecY [174] is nicely explained by its multiple interactions on the opposite side of the SecY barrel from TMS2 and TMS7, and the juxtaposition of SecE from adjacent complexes is consistent with previous studies showing that they can be cross-linked [124,125]. However, these SecE–SecE contacts seem to obstruct the previously proposed pore between two SecYEG complexes in a dimer [127]. Moreover, some of the most efficient cross-links, in particular between TMS7 of SecY and TMS3 of SecE [125], cannot be explained by the crystal structure. A central hydrophobic constriction in the SecY barrel formed by isoleucine residues closes the putative channel for transmembrane ion movements. The “plug” loop mentioned before could form a gate that controls access to the channel on the external side of the membrane. However, the channel is too narrow, even if fully distended, to accommodate a disulfide loop, let alone SecA, and is far smaller than the experimentally determined internal diameter of the Sec61p channel in eukaryotes [175,176]. Obviously, the pore in the monomeric SecY has to dilate to accommodate more than a single polypeptide chain or a loop structure of signal sequence and mature domain. With our current understanding of the structure, it is difficult to envisage how such a highly organized, rigid structure of the barrel would open without many movements of the transmembrane segments. The “plug” domain which corresponds to P1 of SecY can be cross-linked to the P2 loop of SecE [123] to yield an inactive complex. This has led the authors to conclude that the “plug” domain is a flexible region that during the initiation of translocation might leave the structure to open up an hourglass-like channel in the SecY monomer. This may seem an attractive hypothesis but it should be stressed that most intermolecular cross-links inactivate the SecYEG complex, and therefore, it appears that the channel requires an intrinsic flexibility. The “plug” movement, therefore, does not follow from the cross-linking experiments per se.

Another concern is that the size of the monomer is inconsistent with that of the presumed Sec61p complex observed underneath the ribosome in electron micrographs of the two complexes [149]. The ribosome contacts could be established with several Sec61 protomers, possibly as tetramers, with only one of the channels being used for protein translocation and the others, presumably, completely obstructed. It is difficult to understand why such oligomeric assemblies exist if the monomer alone would be sufficient to form a protein conducting channel. Clearly, the structure provides the basis for further exploration, notably the creation of mutations affecting key residues involved in the position of the “plug” loop and the amino acids in the narrow seal. Most *prl* mutations map in the pore region around the “plug” [122]. These could be the residues that define the SecA binding site or that alter accessibility of the surface exposed SecA binding domain, based on the evidence that *prl* suppression correlates with tighter SecA–translocase binding [54,177]. The *prl* mutations in SecY may also shift the pore to an open conformation. *Pr*l mutations also destabilize the SecY–SecE complex [118] but it is unclear how this is achieved as the structure reveals multiple sites of interaction. Further crystallographic studies, most notably those on the translocase in co-complex with SecA, could provide a valuable snapshot of the translocase in action.

## 7. Concluding remarks

During the last two decades, a major advance has been made in our understanding of the mechanism of protein translocation and membrane protein integration. The components of the Sec pathway have been identified and their roles have been defined at the biochemical and enzymological level. Domains and residues important for the functionality of the translocase have been identified by extensive mutational analyses. Subunit interactions within the protein-conducting channel and the association with other subunits have been explored. Electron microscopy studies have provided insight into the dimensions of the channel and, together with other studies, contributed to a better understanding of the oligomeric nature of the channel. The recent success in SecYEG crystallization now provides a detailed insight in the structure of this complex. Future challenges are to obtain structures of co-complexes of SecA with SecYEG, and ultimately, a complex harboring a protein translocation intermediate that would occupy the protein-conducting channel. Several mechanistic questions remain to be solved. For instance, what are the dynamic changes that the channel undergoes during the catalytic cycle of SecA? How does the channel complex participate in the assembly of membrane proteins, and what is the mechanism by which the accessory membrane proteins act on the protein translocation reaction? These are questions to be addressed in future research.



## Acknowledgements

This work was supported by the Council for Chemical Sciences of the Netherlands Organization for Scientific Research (CW-NWO) and subsidized by the Dutch Organization for the Advancement of Scientific Research (NWO), and by European Union Directorate of Science and Technology Grants RTN1-1999-00149 and BIO4 CT 960097. The authors would like to thank Jeanine de Keyzer and Martin van der Laan for critical reading of the manuscript.

## References

- [1] A.J.M. Driessen, E.H. Manting, C. van der Does, The structural basis of protein targeting and translocation in bacteria, *Nat. Struct. Biol.* 8 (2001) 492–498.
- [2] A. Economou, Bacterial protein translocase: a unique molecular machine with an army of substrates, *FEBS Lett.* 476 (2000) 18–21.
- [3] D.B. Oliver, J. Beckwith, *E. coli* mutant pleiotropically defective in the export of secreted proteins, *Cell* 25 (1981) 765–772.
- [4] K. Ito, M. Wittekind, M. Nomura, K. Shiba, T. Yura, A. Miura, H. Nashimoto, A temperature-sensitive mutant of *E. coli* exhibiting slow processing of exported proteins, *Cell* 32 (1983) 789–797.
- [5] P.D. Riggs, A.I. Derman, J. Beckwith, A mutation affecting the regulation of a *secA-lacZ* fusion defines a new *sec* gene, *Genetics* 118 (1988) 571–579.
- [6] K. Nishiyama, M. Hanada, H. Tokuda, Disruption of the gene encoding p12 (SecG) reveals the direct involvement and important function of SecG in the protein translocation of *Escherichia coli* at low temperature, *EMBO J.* 13 (1994) 3272–3277.
- [7] A. Prinz, C. Behrens, T.A. Rapoport, E. Hartmann, K.U. Kalies, Evolutionarily conserved binding of ribosomes to the translocation channel via the large ribosomal RNA, *EMBO J.* 19 (2000) 1900–1906.
- [8] C.R. Zito, D. Oliver, Two-stage binding of SecA to the bacterial translocon regulates ribosome–translocon interaction, *J. Biol. Chem.* 278 (2003) 40640–40646.
- [9] C. Gardel, S. Benson, J. Hunt, S. Michaelis, J. Beckwith, *secD*, a new gene involved in protein export in *Escherichia coli*, *J. Bacteriol.* 169 (1987) 1286–1290.
- [10] C. Gardel, K. Johnson, A. Jacq, J. Beckwith, The *secD* locus of *E. coli* codes for two membrane proteins required for protein export, *EMBO J.* 9 (1990) 3209–3216.
- [11] K.J. Pogliano, J. Beckwith, Genetic and molecular characterization of the *Escherichia coli secD* operon and its products, *J. Bacteriol.* 176 (1994) 804–814.
- [12] F. Duong, W. Wickner, Distinct catalytic roles of the SecYE, SecG and SecDFyajC subunits of preprotein translocase holoenzyme, *EMBO J.* 16 (1997) 2756–2768.
- [13] D. Gorlich, T.A. Rapoport, Protein translocation into proteoliposomes reconstituted from purified components of the endoplasmic reticulum membrane, *Cell* 75 (1993) 615–630.
- [14] M. Nakai, A. Tanaka, T. Omata, T. Endo, Cloning and characterization of the *secY* gene from the cyanobacterium *Synechococcus* PCC7942, *Biochim. Biophys. Acta* 1171 (1992) 113–116.
- [15] C.D. Scaramuzzi, H.W. Stokes, R.G. Hiller, Characterisation of a chloroplast-encoded *secY* homologue and *atpH* from a chromophytic alga. Evidence for a novel chloroplast genome organisation, *FEBS Lett.* 304 (1992) 119–123.
- [16] V. Laidler, A.M. Chaddock, T.G. Knott, D. Walker, C. Robinson, A SecY homolog in *Arabidopsis thaliana*. Sequence of a full-length cDNA clone and import of the precursor protein into chloroplasts, *J. Biol. Chem.* 270 (1995) 17664–17667.
- [17] D. Schuenemann, P. Amin, E. Hartmann, N.E. Hoffman, Chloroplast SecY Is Complexed to SecE and Involved in the Translocation of the 33-kDa but Not the 23-kDa Subunit of the Oxygen-evolving Complex, *J. Biol. Chem.* 274 (1999) 12177–12182.
- [18] M. Nakai, T. Nohara, D. Sugita, T. Endo, Identification and characterization of the *sec-A* protein homologue in the cyanobacterium *Synechococcus* PCC7942, *Biochem. Biophys. Res. Commun.* 200 (1994) 844–851.
- [19] M. Nakai, A. Goto, T. Nohara, D. Sugita, T. Endo, Identification of the SecA protein homolog in pea chloroplasts and its possible involvement in thylakoidal protein transport, *J. Biol. Chem.* 269 (1994) 31338–31341.
- [20] J. Auer, G. Spicker, A. Bock, Presence of a gene in the archaeobacterium *Methanococcus vannielii* homologous to *secY* of eubacteria, *Biochimie* 73 (1991) 683–688.
- [21] E. Arndt, The genes for ribosomal protein L15 and the protein equivalent to *secY* in the archaeobacterium *Haloarcula* (*Halobacterium*) *marismortui*, *Biochim. Biophys. Acta* 1130 (1992) 113–116.
- [22] T. Kath, G. Schafer, A *secY* homologous gene in the crenarchaeon *Sulfolobus acidocaldarius*, *Biochim. Biophys. Acta* 1264 (1995) 155–158.
- [23] L.N. Kinch, M.H. Saier Jr., N.V. Grishin, Sec61beta—a component of the archaeal protein secretory system, *Trends Biochem. Sci.* 27 (2002) 170–171.
- [24] S.D. Emr, S. Hanley-Way, T.J. Silhavy, Suppressor mutations that restore export of a protein with a defective signal sequence, *Cell* 23 (1981) 79–88.
- [25] V.A. Bankaitis, P.J. Bassford Jr., Proper interaction between at least two components is required for efficient export of proteins to the *Escherichia coli* cell envelope, *J. Bacteriol.* 161 (1985) 169–178.
- [26] J. Stader, L.J. Gansheroff, T.J. Silhavy, New suppressors of signal-sequence mutations, *prlG*, are linked tightly to the *secE* gene of *Escherichia coli*, *Genes Dev.* 3 (1989) 1045–1052.
- [27] R.J. Cabelli, L. Chen, P.C. Tai, D.B. Oliver, SecA protein is required for secretory protein translocation into *E. coli* membrane vesicles, *Cell* 55 (1988) 683–692.
- [28] L. Brundage, J.P. Hendrick, E. Schiebel, A.J.M. Driessen, W. Wickner, The purified *E. coli* integral membrane protein SecY/E is sufficient for reconstitution of SecA-dependent precursor protein translocation, *Cell* 62 (1990) 649–657.
- [29] J. Akimaru, S. Matsuyama, H. Tokuda, S. Mizushima, Reconstitution of a protein translocation system containing purified SecY, SecE, and SecA from *Escherichia coli*, *Proc. Natl. Acad. Sci. U. S. A.* 88 (1991) 6545–6549.
- [30] K. Douville, M. Leonard, L. Brundage, K. Nishiyama, H. Tokuda, S. Mizushima, W. Wickner, Band 1 subunit of *Escherichia coli* preprotein translocase and integral membrane export factor P12 are the same protein, *J. Biol. Chem.* 269 (1994) 18705–18707.
- [31] K. Nishiyama, S. Mizushima, H. Tokuda, A novel membrane protein involved in protein translocation across the cytoplasmic membrane of *Escherichia coli*, *EMBO J.* 12 (1993) 3409–3415.
- [32] N. Bonnefoy, F. Chalvet, P. Hamel, P.P. Slonimski, G. Dujardin, *OXA1*, a *Saccharomyces cerevisiae* nuclear gene whose sequence is conserved from prokaryotes to eukaryotes controls cytochrome oxidase biogenesis, *J. Mol. Biol.* 239 (1994) 201–212.
- [33] K. Hell, J. Herrmann, E. Pratje, W. Neupert, R.A. Stuart, Oxa1p mediates the export of the N- and C-termini of pCoxII from the mitochondrial matrix to the intermembrane space, *FEBS Lett.* 418 (1997) 367–370.
- [34] K. Hell, W. Neupert, R.A. Stuart, Oxa1p acts as a general membrane insertion machinery for proteins encoded by mitochondrial DNA, *EMBO J.* 20 (2001) 1281–1288.
- [35] J.C. Samuelson, M. Chen, F. Jiang, I. Moller, M. Wiedmann, A. Kuhn, G.J. Phillips, R.E. Dalbey, YidC mediates membrane protein insertion in bacteria, *Nature* 406 (2000) 637–641.
- [36] P.A. Scotti, M.L. Urbanus, J. Brunner, J.W. de Gier, G. von Heijne, C. van der Does, A.J.M. Driessen, B. Oudega, J. Luirink, YidC, the



- Escherichia coli* homologue of mitochondrial Oxa1p, is a component of the Sec translocase, EMBO J. 19 (2000) 542–549.
- [37] N. Nouwen, A.J.M. Driessen, SecDFyajC forms a heterotrimeric complex with YidC, Mol. Microbiol. 44 (2002) 1397–1405.
- [38] D.P. Cerretti, D. Dean, G.R. Davis, D.M. Bedwell, M. Nomura, The *spc* ribosomal protein operon of *Escherichia coli*: sequence and cotranscription of the ribosomal protein genes and a protein export gene, Nucleic Acids Res. 11 (1983) 2599–2616.
- [39] Y. Akiyama, K. Ito, Topology analysis of the SecY protein, an integral membrane protein involved in protein export in *Escherichia coli*, EMBO J. 6 (1987) 3465–3470.
- [40] E. Hartmann, T. Sommer, S. Prehn, D. Gorlich, S. Jentsch, T.A. Rapoport, Evolutionary conservation of components of the protein translocation complex, Nature 367 (1994) 654–657.
- [41] M. Pohlschroder, W.A. Prinz, E. Hartmann, J. Beckwith, Protein translocation in the three domains of life: variations on a theme, Cell 91 (1997) 563–566.
- [42] J. Eichler, Archaeal protein translocation crossing membranes in the third domain of life, Eur. J. Biochem. 267 (2000) 3402–3412.
- [43] T. Shimoike, Y. Akiyama, T. Baba, T. Taura, K. Ito, SecY variants that interfere with *Escherichia coli* protein export in the presence of normal SecY, Mol. Microbiol. 6 (1992) 1205–1210.
- [44] H. Mori, K. Ito, An essential amino acid residue in the protein translocation channel revealed by targeted random mutagenesis of SecY, Proc. Natl. Acad. Sci. U. S. A. 98 (2001) 5128–5133.
- [45] S.D. Emr, P.J. Bassford Jr., Localization and processing of outer membrane and periplasmic proteins in *Escherichia coli* strains harboring export-specific suppressor mutations, J. Biol. Chem. 257 (1982) 5852–5860.
- [46] J. Stader, S.A. Benson, T.J. Silhavy, Kinetic analysis of  $\lambda$ mb mutants suggests the signal sequence plays multiple roles in protein export, J. Biol. Chem. 261 (1986) 15075–15080.
- [47] J.W. Puziss, S.M. Strobel, P.J. Bassford Jr., Export of maltose-binding protein species with altered charge distribution surrounding the signal peptide hydrophobic core in *Escherichia coli* cells harboring *prl* suppressor mutations, J. Bacteriol. 174 (1992) 92–101.
- [48] R.S. Osborne, T.J. Silhavy, PrlA suppressor mutations cluster in regions corresponding to three distinct topological domains, EMBO J. 12 (1993) 3391–3398.
- [49] O. Francetic, M.P. Hanson, C.A. Kumamoto, *prlA* suppression of defective export of maltose-binding protein in *secB* mutants of *Escherichia coli*, J. Bacteriol. 175 (1993) 4036–4044.
- [50] M.K. Olsen, E.L. Rosey, C.S. Tomich, Isolation and analysis of novel mutants of *Escherichia coli prlA (secY)*, J. Bacteriol. 175 (1993) 7092–7096.
- [51] A.I. Derman, J.W. Puziss, P.J. Bassford Jr., J. Beckwith, A signal sequence is not required for protein export in *prlA* mutants of *Escherichia coli*, EMBO J. 12 (1993) 879–888.
- [52] A.M. Flower, R.C. Doebele, T.J. Silhavy, PrlA and PrlG suppressors reduce the requirement for signal sequence recognition, J. Bacteriol. 176 (1994) 5607–5614.
- [53] W.A. Prinz, C. Spiess, M. Ehrmann, C. Schierle, J. Beckwith, Targeting of signal sequenceless proteins for export in *Escherichia coli* with altered protein translocase, EMBO J. 15 (1996) 5209–5217.
- [54] J.P. van der Wolk, P. Fekkes, A. Boorsma, J.L. Huie, T.J. Silhavy, A.J.M. Driessen, PrlA4 prevents the rejection of signal sequence defective preproteins by stabilizing the SecA–SecY interaction during the initiation of translocation, EMBO J. 17 (1998) 3631–3639.
- [55] T. Iino, T. Sako, Inhibition and resumption of processing of the staphylokinase in some *Escherichia coli prlA* suppressor mutants, J. Biol. Chem. 263 (1988) 19077–19082.
- [56] T. Sako, T. Iino, Distinct mutation sites in *prlA* suppressor mutant strains of *Escherichia coli* respond either to suppression of signal peptide mutations or to blockage of staphylokinase processing, J. Bacteriol. 170 (1988) 5389–5391.
- [57] P.J. Schatz, P.D. Riggs, A. Jacq, M.J. Fath, J. Beckwith, The *secE* gene encodes an integral membrane protein required for protein export in *Escherichia coli*, Genes Dev. 3 (1989) 1035–1044.
- [58] C.K. Murphy, J. Beckwith, Residues essential for the function of SecE, a membrane component of the *Escherichia coli* secretion apparatus, are located in a conserved cytoplasmic region, Proc. Natl. Acad. Sci. U. S. A. 91 (1994) 2557–2561.
- [59] P.J. Schatz, K.L. Bieker, K.M. Ottemann, T.J. Silhavy, J. Beckwith, One of three transmembrane stretches is sufficient for the functioning of the SecE protein, a membrane component of the *E. coli* secretion machinery, EMBO J. 10 (1991) 1749–1757.
- [60] K. Nishiyama, S. Mizushima, H. Tokuda, The carboxyl-terminal region of SecE interacts with SecY and is functional in the reconstitution of protein translocation activity in *Escherichia coli*, J. Biol. Chem. 267 (1992) 7170–7176.
- [61] S.M. Jeong, H. Yoshikawa, H. Takahashi, Isolation and characterization of the *secE* homologue gene of *Bacillus subtilis*, Mol. Microbiol. 10 (1993) 133–142.
- [62] L. Froderberg, T. Rohl, K.J. van Wijk, J.W. de Gier, Complementa-tion of bacterial SecE by a chloroplastic homologue, FEBS Lett. 498 (2001) 52–56.
- [63] E. Matsuo, H. Mori, K. Ito, Interfering mutations provide *in vivo* evidence that *Escherichia coli* SecE functions in multimeric states, Mol. Genet. Genomics 268 (2003) 808–815.
- [64] M. Pohlschroder, C. Murphy, J. Beckwith, *In vivo* analyses of interactions between SecE and SecY, core components of the *Escherichia coli* protein translocation machinery, J. Biol. Chem. 271 (1996) 19908–19914.
- [65] V.P. Kontinen, M. Yamanaka, K. Nishiyama, H. Tokuda, Roles of the conserved cytoplasmic region and non-conserved carboxy-terminal region of SecE in *Escherichia coli* protein translocase, J. Biochem. (Tokyo) 119 (1996) 1124–1130.
- [66] K. Nishiyama, T. Suzuki, H. Tokuda, Inversion of the membrane topology of SecG coupled with SecA-dependent preprotein translocation, Cell 85 (1996) 71–81.
- [67] S. Bost, D. Belin, A new genetic selection identifies essential residues in SecG, a component of the *Escherichia coli* protein export machinery, EMBO J. 14 (1995) 4412–4421.
- [68] A.M. Flower, L.L. Hines, P.L. Pfennig, SecG is an auxiliary component of the protein export apparatus of *Escherichia coli*, Mol. Genet. 263 (2000) 131–136.
- [69] M. Hanada, K. Nishiyama, H. Tokuda, SecG plays a critical role in protein translocation in the absence of the proton motive force as well as at low temperature, FEBS Lett. 381 (1996) 25–28.
- [70] S. Nagamori, K. Nishiyama, H. Tokuda, Membrane topology inversion of SecG detected by labeling with a membrane-impermeable sulfhydryl reagent that causes a close association of SecG with SecA, J. Biochem. (Tokyo) 132 (2002) 629–634.
- [71] S. Nagamori, K. Nishiyama, H. Tokuda, Two SecG molecules present in a single protein translocation machinery are functional even after cross-linking, J. Biochem. 128 (2000) 129–137.
- [72] H. Suzuki, K. Nishiyama, H. Tokuda, Coupled structure changes of SecA and SecG revealed by the synthetic lethality of the *secAcsR11* and  $\Delta$ secG::kan double mutant, Mol. Microbiol. 29 (1998) 331–341.
- [73] G. Matsumoto, H. Mori, K. Ito, Roles of SecG in ATP- and SecA-dependent protein translocation, Proc. Natl. Acad. Sci. U. S. A. 95 (1998) 13567–13572.
- [74] V.P. Kontinen, H. Tokuda, Overexpression of phosphatidylglycerophosphate synthase restores protein translocation in a *secG* deletion mutant of *Escherichia coli* at low temperature, FEBS Lett. 364 (1995) 157–160.
- [75] H. Shimizu, K. Nishiyama, H. Tokuda, Expression of *gpsA* encoding biosynthetic *sn*-glycerol 3-phosphate dehydrogenase suppresses both the LB-phenotype of a *secB* null mutant and the cold-sensitive phenotype of a *secG* null mutant, Mol. Microbiol. 26 (1997) 1013–1021.
- [76] S. Bost, D. Belin, *prl* mutations in the *Escherichia coli secG* gene, J. Biol. Chem. 272 (1997) 4087–4093.

- [77] S. Bost, F. Silva, C. Rudaz, D. Belin, Both transmembrane domains of SecE contribute to signal sequence recognition by the *Escherichia coli* protein export machinery, *Mol. Microbiol.* 38 (2000) 575–587.
- [78] R.J. Cabelli, K.M. Dolan, L.P. Qian, D.B. Oliver, Characterization of membrane-associated and soluble states of SecA protein from wild-type and *SecA51(TS)* mutant strains of *Escherichia coli*, *J. Biol. Chem.* 266 (1991) 24420–24427.
- [79] M. Akita, A. Shinaki, S. Matsuyama, S. Mizushima, SecA, an essential component of the secretory machinery of *Escherichia coli*, exists as homodimer, *Biochem. Biophys. Res. Commun.* 174 (1991) 211–216.
- [80] A.J.M. Driessen, SecA, the peripheral subunit of the *Escherichia coli* precursor protein translocase, is functional as a dimer, *Biochemistry* 32 (1993) 13190–13197.
- [81] H. Ding, J.F. Hunt, I. Mukerji, D. Oliver, *Bacillus subtilis* SecA ATPase exists as an antiparallel dimer in solution, *Biochemistry* 42 (2003) 8729–8738.
- [82] F.U. Hartl, S. Lecker, E. Schiebel, J.P. Hendrick, W. Wickner, The binding cascade of SecB to SecA to SecY/E mediates preprotein targeting to the *E. coli* plasma membrane, *Cell* 63 (1990) 269–279.
- [83] P. Fekkes, J.G. de Wit, J.P. van der Wolk, H.H. Kimsey, C.A. Kumamoto, A.J.M. Driessen, Preprotein transfer to the *Escherichia coli* translocase requires the co-operative binding of SecB and the signal sequence to SecA, *Mol. Microbiol.* 29 (1998) 1179–1190.
- [84] P. Fekkes, C. van der Does, A.J.M. Driessen, The molecular chaperone SecB is released from the carboxy-terminus of SecA during initiation of precursor protein translocation, *EMBO J.* 16 (1997) 6105–6113.
- [85] R. Lill, W. Dowhan, W. Wickner, The ATPase activity of SecA is regulated by acidic phospholipids, SecY, and the leader and mature domains of precursor proteins, *Cell* 60 (1990) 271–280.
- [86] E. Schiebel, A.J.M. Driessen, F.U. Hartl, W. Wickner, Delta mu H<sup>+</sup> and ATP function at different steps of the catalytic cycle of preprotein translocase, *Cell* 64 (1991) 927–939.
- [87] J.P. van der Wolk, J.G. de Wit, A.J.M. Driessen, The catalytic cycle of the *Escherichia coli* SecA ATPase comprises two distinct preprotein translocation events, *EMBO J.* 16 (1997) 7297–7304.
- [88] J.F. Hunt, S. Weinkauf, L. Henry, J.J. Fak, P. McNicholas, D.B. Oliver, J. Deisenhofer, Nucleotide control of interdomain interactions in the conformational reaction cycle of SecA, *Science* 297 (2002) 2018–2026.
- [89] V. Sharma, A. Arockiasamy, D.R. Ronning, C.G. Savva, A. Holzenburg, M. Braunstein, W.R. Jacobs Jr., J.C. Sacchettini, Crystal structure of *Mycobacterium tuberculosis* SecA, a preprotein translocating ATPase, *Proc. Natl. Acad. Sci. U. S. A.* 100 (2003) 2243–2248.
- [90] D.B. Oliver, R.J. Cabelli, K.M. Dolan, G.P. Jarosik, Azide-resistant mutants of *Escherichia coli* alter the SecA protein, an azide-sensitive component of the protein export machinery, *Proc. Natl. Acad. Sci. U. S. A.* 87 (1990) 8227–8231.
- [91] J.L. Huie, T.J. Silhavy, Suppression of signal sequence defects and azide resistance in *Escherichia coli* commonly result from the same mutations in SecA, *J. Bacteriol.* 177 (1995) 3518–3526.
- [92] M. Schmidt, H. Ding, V. Ramamurthy, I. Mukerji, D. Oliver, Nucleotide binding activity of SecA homodimer is conformationally regulated by temperature and altered by *prlD* and *azi* mutations, *J. Biol. Chem.* 275 (2000) 15440–15448.
- [93] A. Bolhuis, C.P. Broekhuizen, A. Sorokin, M.L. van Roosmalen, G. Venema, S. Bron, W.J. Quax, J.M. van Dijk, SecDF of *Bacillus subtilis*, a molecular Siamese twin required for the efficient secretion of proteins, *J. Biol. Chem.* 273 (1998) 21217–21224.
- [94] T.T. Tseng, K.S. Gratwick, J. Kollman, D. Park, D.H. Nies, A. Goffeau, M.H. Saier Jr., The RND permease superfamily: an ancient, ubiquitous and diverse family that includes human disease and development proteins, *J. Mol. Microbiol. Biotechnol.* 1 (1999) 107–125.
- [95] Y. Kato, K. Nishiyama, H. Tokuda, Depletion of SecDF-YajC causes a decrease in the level of SecE: implication for their functional interaction, *FEBS Lett.* 550 (2003) 114–118.
- [96] J.A. Pogliano, J. Beckwith, SecD and SecF facilitate protein export in *Escherichia coli*, *EMBO J.* 13 (1994) 554–561.
- [97] Y.J. Kim, T. Rajapandi, D. Oliver, SecA protein is exposed to the periplasmic surface of the *E. coli* inner membrane in its active state, *Cell* 78 (1994) 845–853.
- [98] A. Economou, J.A. Pogliano, J. Beckwith, D.B. Oliver, W. Wickner, SecA membrane cycling at SecYEG is driven by distinct ATP binding and hydrolysis events and is regulated by SecD and SecF, *Cell* 83 (1995) 1171–1181.
- [99] S. Matsuyama, Y. Fujita, S. Mizushima, SecD is involved in the release of translocated secretory proteins from the cytoplasmic membrane of *Escherichia coli*, *EMBO J.* 12 (1993) 265–270.
- [100] A. Saaf, M. Monne, J.W. de Gier, G. von Heijne, Membrane topology of the 60-kDa Oxa1p homologue from *Escherichia coli*, *J. Biol. Chem.* 273 (1998) 30415–30418.
- [101] M.L. Urbanus, P.A. Scotti, L. Froderberg, A. Saaf, J.W. de Gier, J. Brunner, J.C. Samuelson, R.E. Dalbey, B. Oudega, J. Luirink, Sec-dependent membrane protein insertion: sequential interaction of nascent FtsQ with SecY and YidC, *EMBO Rep.* 2 (2001) 524–529.
- [102] M. van der Laan, M.L. Urbanus, C.M. Hagen-Jongman, N. Nouwen, B. Oudega, N. Harms, A.J.M. Driessen, J. Luirink, A conserved function of YidC in the biogenesis of respiratory chain complexes, *Proc. Natl. Acad. Sci. U. S. A.* 100 (2003) 5801–5806.
- [103] L. Yi, F. Jiang, M. Chen, B. Cain, A. Bolhuis, R.E. Dalbey, YidC Is Strictly Required for Membrane Insertion of Subunits a and c of the F(1)F(0)ATP Synthase and SecE of the SecYEG Translocase, *Biochemistry* 42 (2003) 10537–10544.
- [104] J. Helmers, D. Schmidt, J.S. Glavy, G. Blobel, T. Schwartz, The beta-subunit of the protein-conducting channel of the endoplasmic reticulum functions as the guanine nucleotide exchange factor for the beta-subunit of the signal recognition particle receptor, *J. Biol. Chem.* 278 (2003) 23686–23690.
- [105] K. Finke, K. Plath, S. Panzner, S. Prehn, T.A. Rapoport, E. Hartmann, T. Sommer, A second trimeric complex containing homologs of the Sec61p complex functions in protein transport across the ER membrane of *S. cerevisiae*, *EMBO J.* 15 (1996) 1482–1494.
- [106] B.M. Wilkinson, J.R. Tyson, C.J. Stirling, Ssh1p determines the translocation and dislocation capacities of the yeast endoplasmic reticulum, *Dev. Cell* 1 (2001) 401–409.
- [107] A. Robb, J.D. Brown, Protein transport: two translocons are better than one, *Mol. Cell* 8 (2001) 484–486.
- [108] S.E. Douglas, A *secY* homologue is found in the plastid genome of *Cryptomonas phi*, *FEBS Lett.* 298 (1992) 93–96.
- [109] R. Flachmann, C.B. Michalowski, W. Löffelhardt, H.J. Bohnert, SecY, an integral subunit of the bacterial preprotein translocase, is encoded by a plastid genome, *J. Biol. Chem.* 268 (1993) 7514–7519.
- [110] H. Vogel, S. Fischer, K. Valentin, A model for the evolution of the plastid sec apparatus inferred from *secY* gene phylogeny, *Plant Mol. Biol.* 32 (1996) 685–692.
- [111] G. Burger, B.F. Lang, Parallels in genome evolution in mitochondria and bacterial symbionts, *IUBMB, Life* 55 (2003) 205–212.
- [112] A. Kihara, Y. Akiyama, K. Ito, FtsH is required for proteolytic elimination of uncomplexed forms of SecY, an essential protein translocase subunit, *Proc. Natl. Acad. Sci. U. S. A.* 92 (1995) 4532–4536.
- [113] T. Taura, T. Baba, Y. Akiyama, K. Ito, Determinants of the quantity of the stable SecY complex in the *Escherichia coli* cell, *J. Bacteriol.* 175 (1993) 7771–7775.
- [114] J.C. Joly, M.R. Leonard, W.T. Wickner, Subunit dynamics in *Escherichia coli* preprotein translocase, *Proc. Natl. Acad. Sci. U. S. A.* 91 (1994) 4703–4707.
- [115] J. Swaving, K.H. van Wely, A.J.M. Driessen, Preprotein Translocase

- tion by a Hybrid Translocase Composed of *Escherichia coli* and *Bacillus subtilis* subunits, *J. Bacteriol.* 181 (1999) 7021–7027.
- [116] T. Baba, T. Taura, T. Shimoike, Y. Akiyama, T. Yoshihisa, K. Ito, A cytoplasmic domain is important for the formation of a SecY–SecE translocator complex, *Proc. Natl. Acad. Sci. U. S. A.* 91 (1994) 4539–4543.
- [117] T. Homma, T. Yoshihisa, K. Ito, Subunit interactions in the *Escherichia coli* protein translocase: SecE and SecG associate independently with SecY, *FEBS Lett.* 408 (1997) 11–15.
- [118] H. Mori, Y. Akiyama, K. Ito, A SecE mutation that modulates secY–secE translocase assembly, identified as a specific suppressor of SecY defects, *J. Bacteriol.* 185 (2003) 948–956.
- [119] B.A. Katz, A. Kossiakoff, The crystallographically determined structures of atypical strained disulfides engineered into subtilisin, *J. Biol. Chem.* 261 (1986) 15480–15485.
- [120] B. Hazes, B.W. Dijkstra, Model building of disulfide bonds in proteins with known three-dimensional structure, *Protein Eng.* 2 (1988) 119–125.
- [121] Y. Satoh, H. Mori, K. Ito, Nearest neighbor analysis of the SecYEG complex. 2. Identification of a SecY–SecE cytosolic interface, *Biochemistry* 42 (2003) 7442–7447.
- [122] A.M. Flower, R.S. Osborne, T.J. Silhavy, The allele-specific synthetic lethality of *prlA–prlG* double mutants predicts interactive domains of SecY and SecE, *EMBO J.* 14 (1995) 884–893.
- [123] C.R. Harris, T.J. Silhavy, Mapping an Interface of SecY (PrlA) and SecE (PrlG) by using synthetic phenotypes and in vivo cross-linking, *J. Bacteriol.* 181 (1999) 3438–3444.
- [124] A. Kaufmann, E.H. Manting, A.K.J. Veenendaal, A.J.M. Driessen, C. van der Does, Cysteine-directed cross-linking demonstrates that helix 3 of SecE is close to helix 2 of SecY and helix 3 of a neighboring SecE, *Biochemistry* 38 (1999) 9115–9125.
- [125] A.K.J. Veenendaal, C. van der Does, A.J.M. Driessen, Mapping the Sites of Interaction between SecY and SecE by Cysteine Scanning Mutagenesis, *J. Biol. Chem.* 276 (2001) 32559–32566.
- [126] A.K.J. Veenendaal, C. van der Does, A.J.M. Driessen, The core of the bacterial translocase harbors a tilted transmembrane segment 3 of SecE, *J. Biol. Chem.* 277 (2002) 36640–36645.
- [127] C. Breyton, W. Haase, T.A. Rapoport, W. Kuhlbrandt, I. Collinson, Three-dimensional structure of the bacterial protein–translocation complex SecYEG, *Nature* 418 (2002) 662–665.
- [128] B. van den Berg, W.M. Clemons Jr., I. Collinson, Y. Modis, E. Hartmann, S.C. Harrison, T.A. Rapport, X-ray structure of a protein-conducting channel, *Nature* 427 (2004) 36–44.
- [129] K. Nishiyama, S. Mizushima, H. Tokuda, Preferential interaction of Sec-G with Sec-E stabilizes an unstable Sec-E derivative in the *Escherichia coli* cytoplasmic membrane, *Biochem. Biophys. Res. Commun.* 217 (1995) 217–223.
- [130] E. van der Sluis, N. Nouwen, A.J.M. Driessen, SecY–SecY and SecY–SecG contacts revealed by site-specific cross-linking, *FEBS Lett.* 527 (2002) 159.
- [131] Y. Satoh, G. Matsumoto, H. Mori, K. Ito, Nearest neighbor analysis of the SecYEG complex. 1. Identification of a SecY–SecG interface, *Biochemistry* 42 (2003) 7434–7441.
- [132] R. Lill, K. Cunningham, L.A. Brundage, K. Ito, D. Oliver, W. Wickner, SecA protein hydrolyzes ATP and is an essential component of the protein translocation ATPase of *Escherichia coli*, *EMBO J.* 8 (1989) 961–966.
- [133] P. Natale, J. Swaving, C. van der Does, J. de Keyzer, A.J.M. Driessen, Binding of SecA to the SecYEG complex accelerates the rate of nucleotide exchange on SecA, *J. Biol. Chem.* 279 (2004) 13709–13777.
- [134] E.H. Manting, C. van der Does, A.J.M. Driessen, In vivo cross-linking of the SecA and SecY subunits of the *Escherichia coli* preprotein translocase, *J. Bacteriol.* 179 (1997) 5699–5704.
- [135] S. Snyder, V. Ramamurthy, D. Oliver, Identification of a region of interaction between *Escherichia coli* SecA and SecY proteins, *J. Biol. Chem.* 272 (1997) 11302–11306.
- [136] G. Matsumoto, T. Yoshihisa, K. Ito, SecY and SecA interact to allow SecA insertion and protein translocation across the *Escherichia coli* plasma membrane, *EMBO J.* 16 (1997) 6384–6393.
- [137] T. Taura, T. Yoshihisa, K. Ito, Protein translocation functions of *Escherichia coli* SecY: in vitro characterization of cold-sensitive SecY mutants, *Biochimie* 79 (1997) 517–521.
- [138] H. Mori, H. Sugiyama, M. Yamanaka, K. Sato, M. Tagaya, S. Mizushima, Amino-terminal region of SecA is involved in the function of SecG for protein translocation into *Escherichia coli* membrane vesicles, *J. Biochem. (Tokyo)* 124 (1998) 122–129.
- [139] M. Hanada, K. Nishiyama, S. Mizushima, H. Tokuda, Reconstitution of an efficient protein translocation machinery comprising SecA and the three membrane proteins, SecY, SecE, and SecG (p12), *J. Biol. Chem.* 269 (1994) 23625–23631.
- [140] J. de Keyzer, C. van der Does, T.G. Kloosterman, A.J.M. Driessen, Direct demonstration of ATP-dependent release of SecA from a translocating preprotein by surface plasmon resonance, *J. Biol. Chem.* 278 (2003) 29581–29586.
- [141] K. Sagara, S. Matsuyama, S. Mizushima, SecF stabilizes SecD and SecY, components of the protein translocation machinery of the *Escherichia coli* cytoplasmic membrane, *J. Bacteriol.* 176 (1994) 4111–4116.
- [142] T. Taura, Y. Akiyama, K. Ito, Genetic analysis of SecY: additional export-defective mutations and factors affecting their phenotypes, *Mol. Gen. Genet.* 243 (1994) 261–269.
- [143] E.N. Houben, P.A. Scotti, Q.A. Valent, J. Brunner, J.L. de Gier, B. Oudega, J. Luirink, Nascent Lep inserts into the *Escherichia coli* inner membrane in the vicinity of YidC, SecY and SecA, *FEBS Lett.* 476 (2000) 229–233.
- [144] M. van der Laan, E.N. Houben, N. Nouwen, J. Luirink, A.J.M. Driessen, Reconstitution of Sec-dependent membrane protein insertion: nascent FtsQ interacts with YidC in a SecYEG-dependent manner, *EMBO Rep.* 2 (2001) 519–523.
- [145] K. Beck, G. Eisner, D. Trescher, R.E. Dalbey, J. Brunner, M. Muller, YidC, an assembly site for polytopic *Escherichia coli* membrane proteins located in immediate proximity to the SecYE translocon and lipids, *EMBO Rep.* 2 (2001) 709–714.
- [146] M.L. Urbanus, L. Froderberg, D. Drew, P. Bjork, J.W. de Gier, J. Brunner, B. Oudega, J. Luirink, Targeting, insertion, and localization of *Escherichia coli* YidC, *J. Biol. Chem.* 277 (2002) 12718–12723.
- [147] D. Gorlich, S. Prehn, E. Hartmann, K.U. Kalies, T.A. Rapoport, A mammalian homolog of SEC61p and SECYp is associated with ribosomes and nascent polypeptides during translocation, *Cell* 71 (1992) 489–503.
- [148] K.U. Kalies, D. Gorlich, T.A. Rapoport, Binding of ribosomes to the rough endoplasmic reticulum mediated by the Sec61p-complex, *J. Cell Biol.* 126 (1994) 925–934.
- [149] R. Beckmann, D. Bubeck, R. Grassucci, P. Penczek, A. Verschoor, G. Blobel, J. Frank, Alignment of conduits for the nascent polypeptide chain in the ribosome–Sec61 complex, *Science* 278 (1997) 2123–2126.
- [150] J.F. Menetret, A. Neuhof, D.G. Morgan, K. Plath, M. Radermacher, T.A. Rapoport, C.W. Akey, The structure of ribosome-channel complexes engaged in protein translocation, *Mol. Cell* 6 (2000) 1219–1232.
- [151] R. Beckmann, C.M. Spahn, N. Eswar, J. Helmers, P.A. Penczek, A. Sali, J. Frank, G. Blobel, Architecture of the protein-conducting channel associated with the translating 80S ribosome, *Cell* 107 (2001) 361–372.
- [152] M.D. Potter, C.V. Nicchitta, Endoplasmic reticulum-bound ribosomes reside in stable association with the translocon following termination of protein synthesis, *J. Biol. Chem.* 277 (2002) 23314–23320.
- [153] J.C. Joly, W.T. Wickner, The SecA and SecY subunits of translocase are the nearest neighbors of a translocating preprotein, shielding it from phospholipids, *EMBO J.* 12 (1993) 255–263.
- [154] K.S. Crowley, S. Liao, V.E. Worrell, G.D. Reinhart, A.E. Johnson,

- Secretory proteins move through the endoplasmic reticulum membrane via an aqueous, gated pore, *Cell* 78 (1994) 461–471.
- [155] K. Plath, W. Mothes, B.M. Wilkinson, C.J. Stirling, T.A. Rapoport, Signal sequence recognition in posttranslational protein transport across the yeast ER membrane, *Cell* 94 (1998) 795–807.
- [156] B.M. Wilkinson, Y. Esnault, R.A. Craven, F. Skiba, J. Fieschi, F. K'epes, C.J. Stirling, Molecular architecture of the ER translocase probed by chemical cross-linking of Sss1p to complementary fragments of Sec61p, *EMBO J.* 16 (1997) 4549–4559.
- [157] D. Hanein, K.E. Matlack, B. Jungnickel, K. Plath, K.U. Kalies, K.R. Miller, T.A. Rapoport, C.W. Akey, Oligomeric rings of the Sec61p complex induced by ligands required for protein translocation, *Cell* 87 (1996) 721–732.
- [158] K.H.M. van Wely, J. Swaving, C.P. Broekhuizen, M. Rose, W.J. Quax, A.J.M. Driessen, Functional identification of the product of the *Bacillus subtilis* *yvaL* gene as a SecG homologue, *J. Bacteriol.* 181 (1999) 1786–1792.
- [159] T.H. Meyer, J.F. Ménétret, R. Breitling, K.R. Miller, C.W. Akey, T.A. Rapoport, The Bacterial SecY/E translocation complex forms channel-like structures similar to those of the eukaryotic Sec61p complex, *J. Mol. Biol.* 285 (1999) 1789–1800.
- [160] E.H. Manting, C. van der Does, H. Remigy, A. Engel, A.J.M. Driessen, SecYEG assembles into a tetramer to form the active protein translocation channel, *EMBO J.* 19 (2000) 852–861.
- [161] I. Collinson, C. Breyton, F. Duong, C. Tziatzios, D. Schubert, E. Or, T. Rapoport, W. Kuhlbrandt, Projection structure and oligomeric properties of a bacterial core protein translocase, *EMBO J.* 20 (2001) 2462–2471.
- [162] P. Bessonneau, V. Besson, I. Collinson, F. Duong, The SecYEG preprotein translocation channel is a conformationally dynamic and dimeric structure, *EMBO J.* 21 (2002) 995–1003.
- [163] H. Mori, T. Tsukazaki, R. Masui, S. Kuramitsu, S. Yokoyama, A.E. Johnson, Y. Kimura, Y. Akiyama, K. Ito, Fluorescence resonance energy transfer analysis of protein translocase. SecYE from *Thermus thermophilus* HB8 forms a constitutive oligomer in membranes, *J. Biol. Chem.* 278 (2003) 14257–14264.
- [164] F. Duong, Binding, activation and dissociation of the dimeric SecA ATPase at the dimeric SecYEG translocase, *EMBO J.* 22 (2003) 4375–4384.
- [165] T.L. Yahr, W.T. Wickner, Evaluating the oligomeric state of SecYEG in preprotein translocase, *EMBO J.* 19 (2000) 4393–4401.
- [166] A.J.M. Driessen, W. Wickner, Proton transfer is rate-limiting for translocation of precursor proteins by the *Escherichia coli* translocase, *Proc. Natl. Acad. Sci. U. S. A.* 88 (1991) 2471–2475.
- [167] K. Tani, H. Tokuda, S. Mizushima, Translocation of ProOmpA possessing an intramolecular disulfide bridge into membrane vesicles of *Escherichia coli*. Effect of membrane energization, *J. Biol. Chem.* 265 (1990) 17341–17347.
- [168] K. Tani, S. Mizushima, A chemically cross-linked nonlinear proOmpA molecule can be translocated into everted membrane vesicles of *Escherichia coli* in the presence of the proton motive force, *FEBS Lett.* 285 (1991) 127–131.
- [169] N. Nouwen, B. de Kruijff, J. Tommassen, *prlA* suppressors in *Escherichia coli* relieve the proton electrochemical gradient dependency of translocation of wild-type precursors, *Proc. Natl. Acad. Sci. U. S. A.* 93 (1996) 5953–5957.
- [170] J. de Keyzer, C. van der Does, A.J.M. Driessen, Kinetic analysis of the translocation of fluorescent precursor proteins into *Escherichia coli* membrane vesicles, *J. Biol. Chem.* 277 (2002) 46059–46065.
- [171] F. Duong, W. Wickner, The PrlA and PrlG phenotypes are caused by a loosened association among the translocase SecYEG subunits, *EMBO J.* 18 (1999) 3263–3270.
- [172] H. Mori, Y. Shimizu, K. Ito, Superactive SecY variants that fulfill the essential translocation function with a reduced cellular quantity, *J. Biol. Chem.* 277 (2002) 48550–48557.
- [173] E.H. Manting, A. Kaufmann, C. van der Does, A.J.M. Driessen, A Single Amino Acid Substitution in SecY Stabilizes the Interaction with SecA, *J. Biol. Chem.* 274 (1999) 23868–23874.
- [174] S. Matsuyama, J. Akimaru, S. Mizushima, SecE-dependent overproduction of SecY in *Escherichia coli*. Evidence for interaction between two components of the secretory machinery, *FEBS Lett.* 269 (1990) 96–100.
- [175] B.D. Hamman, J.C. Chen, E.E. Johnson, A.E. Johnson, The aqueous pore through the translocon has a diameter of 40–60 Å during cotranslational protein translocation at the ER membrane, *Cell* 89 (1997) 535–544.
- [176] A. Wirth, M. Jung, C. Bies, M. Frie, J. Tyedmers, R. Zimmermann, R. Wagner, The Sec61p complex is a dynamic precursor activated channel, *Mol. Cell* 12 (2003) 261–268.
- [177] J. de Keyzer, C. van der Does, J. Swaving, A.J.M. Driessen, The F286Y mutation of PrlA4 tempers the signal sequence suppressor phenotype by reducing the SecA binding affinity, *FEBS Lett.* 510 (2002) 17–21.