

University of Groningen

Oesophageal speech after laryngectomy (slokdarmspraak)

Damsté, Pieter Helbert

IMPORTANT NOTE: You are advised to consult the publisher's version (publisher's PDF) if you wish to cite from it. Please check the document version below.

Document Version

Publisher's PDF, also known as Version of record

Publication date:

1958

[Link to publication in University of Groningen/UMCG research database](#)

Citation for published version (APA):

Damsté, P. H. (1958). Oesophageal speech after laryngectomy (slokdarmspraak) [S.l.]: [S.n.]

Copyright

Other than for strictly personal use, it is not permitted to download or to forward/distribute the text or part of it without the consent of the author(s) and/or copyright holder(s), unless the work is under an open content license (like Creative Commons).

Take-down policy

If you believe that this document breaches copyright please contact us providing details, and we will remove access to the work immediately and investigate your claim.

Downloaded from the University of Groningen/UMCG research database (Pure): <http://www.rug.nl/research/portal>. For technical reasons the number of authors shown on this cover page is limited to 10 maximum.

OESOPHAGEAL SPEECH
AFTER LARYNGECTOMY
(SLOKDARMSPRAAK)

P. H. DAMSTÉ

OESOPHAGEAL SPEECH AFTER LARYNGECTOMY

(SLOKDARMSPRAAK NA DE VERWIJDERING VAN HET STROTTENHOOFD)

STELLINGEN

I

Voor de vroege diagnose van stembandkanker en voor het ontdekken van recidief na röntgentherapie is larynx-stroboscopie een belangrijk hulpmiddel.

II

Bij lijdens aan suikerziekte die bijzonder geneigd zijn tot hypoglycaemie, de z.g. labiele diabetici, vindt men in een opmerkelijk aantal gevallen electro-encephalografische afwijkingen. Het toedienen van fenobarbital blijkt in deze gevallen een gunstige invloed te hebben op de reguleerbaarheid van de diabetes.

III

Tetracaïne komt via het slijmvlies bijna even snel in de bloedbaan als wanneer het intraveneus was geïnjecteerd. Het gevaar bij een uitgebreide oppervlakte-anaesthesie schuilt dan ook niet zozeer in idiosyncrasie of allergie voor het middel, dan wel in een te snelle toediening ervan.

IV

Het eenvoudigste middel om de relatieve vochtigheidsgraad in een ziekenkamer te verhogen is het betrekkelijk laag houden van de luchttemperatuur. Dit scheidt een gunstiger klimaat dan een hoger absoluut vochtgehalte bij hogere temperatuur.

V

De urine van volwassen mannen bevat creatine. Dat sommige handboeken nog het tegendeel vermelden, vindt zijn oorzaak in een onjuiste methodiek ter bepaling van het creatine-gehalte der urine.

VI

Alvorens bij sputumretentie tot tracheotomie over te gaan, moet een grondige poging tot fysisch-therapeutische behandeling worden gedaan.

VII

Het fotodynamisch effect vertoont grote overeenkomst met de indirecte werking van ioniserende straling.

VIII

De spanning van de weke delen (banden en spieren) remt de lengtegroei der botten. Dit komt tot uiting bij de kinderverlamming.

IX

Stembandknobbeltjes en andere manifestaties van functionele dysphonie worden niet blijvend genezen door stemrust, maar door stemtherapie.

X

Articulatie heeft door de samenhang met de resonantie invloed op het statisch aspekt, en via de adembeheersing vooral invloed op het dynamisch aspekt van de toonvorming. Articulatie moet de toon bevorderen en mag deze niet schaden.

XI

Tijdens de uitspraak van ongeaspireerde explosieve medeklinkers is de glottis gesloten.

XII

In tegenstelling tot de heersende opvatting, stemt de slagtoon van een klok dikwijls niet overeen met het oktaaf onder de z.g. 5e partiaal.

XIII

In het belang van de volksgezondheid dienen de bouwvoorschriften ten aanzien van geluidsisolatie in woningblokken te worden verscherpt.

STELLINGEN BEHORENDE BIJ P. H. DAMSTÉ
OESOPHAGEAL SPEECH
GRONINGEN, DECEMBER 1958

RIJKSUNIVERSITEIT TE GRONINGEN

OESOPHAGEAL SPEECH
AFTER LARYNGECTOMY
(MET EEN SAMENVATTING IN HET NEDERLANDS)

PROEFSCHRIFT

TER VERKRIJGING VAN DE GRAAD VAN DOCTOR IN DE GENEESKUNDE
AAN DE RIJKSUNIVERSITEIT TE GRONINGEN,
OP GEZAG VAN DE RECTOR MAGNIFICUS MR. H. J. SCHELTEMA
HOOGLEERAAR IN DE FACULTEIT DER RECHTSGELEERDHEID,
IN HET OPENBAAR TE VERDEDIGEN
OP WOENSDAG 3 DECEMBER 1958
DES NAMIDDAGS TE 4 UUR

DOOR

PIETER HELBERT DAMSTÉ

GEBOREN TE BANDUNG

1958

BOEKDRUKKERIJ VOORHEEN GEBROEDERS HOITSEMA
GRONINGEN

PROMOTOR: PROF. DR. EELCO HUIZINGA

Dit onderzoek is mogelijk gemaakt door een subsidie van de Afd. Medische
Physica van de Gezondheids Organisatie T.N.O.

Gaarne betuig ik mijn dank aan allen, die met raad of daad bij dit onderzoek behulpzaam zijn geweest;

in het bijzonder aan Prof. A. A. J. van Egmond en Dr. G. H. de Wit te Utrecht, aan Prof. L. B. W. Jongkees en Dr. W. H. Struben te Amsterdam, die een aantal van hun patienten voor onderzoek hebben laten komen, en aan Prof. G. J. van der Plaats te Maastricht, die voor het maken van enige röntgenfilmopnamen zijn royale medewerking heeft verleend.

If feel greatly indebted to Dr. A. J. Blayney of Galway, Ireland, for his helpful criticism of parts of the translation.

. . . voir n'est qu'une batarde façon de comprendre.

ALAIN

CONTENTS

I. INTRODUCTION	1
1. rehabilitation	1
2. cancer of the larynx.	1
3. voice-substitutes	2
4. laryngectomy	4
5. vocal tract before and after laryngectomy.	5
6. mechanism of oesophageal speech	6
7. aim of present study	7
II. HISTORICAL SURVEY.	8
III. EXPERIMENTS.	12
1. plan of investigation.	12
2. pressure registration	14
3. table	20
4. tension of oesophageal sphincter	25
5. cineradiography	27
IV. INTAKE OF AIR.	28
1. injection and suction.	29
2. pressure in the pharynx	30
3. glossopharyngeal press in the laryngectomized	30
4. air-injection and swallowing	31
5. teaching the patient	32
6. crossing the cricopharyngeal barrier	32
7. glossopharyngeal speech and -breathing	34
V. THE PSEUDOGLOTTIS	36
1. location.	36
2. name of the voice-substitute	36
3. x-ray examination, shape of pseudoglottis	38
4. acoustic properties.	42
5. exceptional locations	47
VI. AIR-EXPULSION.	55
1. pressure in the oesophagus.	55
2. role of injection and expiration	56
3. connection between speech and expiration	58
VII. REHABILITATION.	60
1. co-operation.	60
2. morale	62
3. impediments	64
4. cases with a pharyngostoma	65
5. validity.	66
SAMENVATTING (in het nederlands).	67
Complete list of references on oesophageal speech and related subjects	73

SECTION I. INTRODUCTION

1. The first half of this century has been characterized by an ever increasing tendency to specialization in medicine. This has arisen because of the rapid growth in medical knowledge both theoretical and technical. While this specialization has brought about many advances in medicine particularly in respect of new major surgical techniques it has also at times tended to make the doctor treat the disease rather than the patient as a whole person. The latter is first disturbed by the disease, and the treatment is not always capable of re-establishing the former state of equilibrium, far from that.

The process of reintegration of the person and his reinstalment to a proper place in society has been termed rehabilitation. This thesis is concerned with a specific type of rehabilitation, namely, the restoration of speech to the laryngectomized patient.

2. By far the most frequent reason for laryngectomy is cancer of the larynx. A brief summary of this condition is perhaps not out of place.

The disease attacks people (mostly men) in the second half of their life. It betrays its onset early by alteration of the voice and later by hoarseness. But this all too common symptom, more often than being a danger signal, hides the early cancer among the many other causes of hoarseness. When left to itself, carcinoma of the vocal cords will lead to a certain death in a few years. Treatment is, in general, conducted along the following lines. When the growth is small and limited to a part of one vocal cord, it is treated by either radiation therapy or extirpation by laryngofissure. If there is deeper infiltration with impairment of the mobility of one vocal cord or a slight extension to the opposite side along the anterior commissure, hemilaryngectomy is performed. In all more advanced cases total laryngectomy is indicated, unless too extensive lymph gland metastases have occurred or local infiltration has gone too far.

The results of treatment of laryngeal carcinoma are far better than of other cancers. 4 % of all malignant disease is situated in the larynx, but only 1½ % of mortality by malignancy is due to laryngeal cancer (GATEWOOD). A survival rate of more than five

years after a total laryngectomy is according to various statements 40—65 %. This means that there is a considerable number of patients that leave the wards deprived of their ability to speak and with many years still to live before them.

3. These people are badly in need of some sort of speech-rehabilitation. Several possibilities exist:

1. Patients who are left to themselves usually develop a kind of forced articulation, with which they are able to communicate with their closest relations and some other good listeners. It is called pseudo-whispered speech. In whispering the voice is replaced by a random noise generated by air-turbulence in the narrowed but not vibrating glottis. In pseudo-whisper any air-stream from the glottis is missing, and what vocal sound there is beside the consonants, is generated by the resonance-cavities being actuated by the fricatives and plosives.

Since it is known that most of the information in speech is carried by the transient sounds, it is not surprising that this pseudo-whispered speech can be fairly well understood. Its penetrating force, however, is very small.

2. Unfortunately in some clinics it is still customary to use an artificial larynx. The multitudinous devices may be classified into two main groups:

a. the mechanical type in which the expiratory air is led from the tracheal canula through a reed-like vibrator and hence with a tube into the back of the mouth;

b. the electrical type in which vibrations are generated by a magnetic or motor-driven buzzer-system. The vibrating membrane is applied to the skin of the throat or the bottom of the mouth. Another electrical type has the shape of a tobacco-pipe; the air-vibrations are produced in the bowl and propagated through the stem to the mouth.

Both types are represented by many modifications, some of these have proved their value over many years. It is not difficult to learn to use an artificial larynx and the speech produced thereby can be understood without undue difficulty. The drawbacks, however, are not to be taken lightly:

1. the sound is monotonous;

2. in the electrical type, speech is accompanied by the un-interrupted buzzing sound of the vibrator;

3. when the apparatus is not at hand or out of order, the patient is unable to speak;

4. despite its small size and its many subtle disguises the modern apparatus is still a constant reminder of the patient's disability, both to himself and to his friends.

5. the cost of purchase and maintenance is still not negligible.

3. 'Parabuccal speech' has been seen in exceptional cases (VAN GILSE), one of whom had learned it as a boy and could put it into practice after his laryngectomy. The air is pressed from an air bubble high in the cheek through a 'rima glottidis' that is formed between the upper alveolar process and the mucosa of the mouth tensed by the buccinator muscle.

Another type of purely buccal speech was seen by us in a case of a 17-year-old boy who had had a laryngeal stenosis since early youth (Chapt. V. 6). Here the vibrations are generated by the lateral edge of the tongue against the lingual side of the upper alveolar process. Air from the pharynx is pressed through this pseudo-glottis by a backward movement of the root of the tongue.

Both these types of pseudo-voice are of theoretical interest only, and are not recommendable for rehabilitation purposes.

4. Oesophageal speech is the method of choice. The difference between oesophageal and normal speech is:

– the air for phonation comes from the oesophagus, not from the lungs;

– the sound vibrations are produced, not by the vocal cords, but by the tissues at the mouth of the oesophagus.

The rest of the vocal tract (the pharyngeal and oral cavities) behaves substantially the same in both normal and oesophageal speech. For that reason, apart from a few exceptions to be mentioned later, phonetic events in this region undergo no change.

Most patients can learn oesophageal speech following daily lessons over a few weeks. This form of speech is very intelligible at short range and although not exactly pleasing to the ear the personal attributes of speech are better, and the voice more human, than with an artificial larynx.

There can be no doubt about who was the inventor of oesophageal

speech; it was a patient, and probably dozens of patients that were unaware of its existence, have invented it over and over again. This appears from the first descriptions in the early literature on the subject. The fundamentals of oesophageal speech are familiar to any boy that exhibits to his schoolfriends the ability to replace initial vowels by belched sounds. No wonder then that a patient deprived of his voice, in his efforts to recapture his power of speech, should hit upon this hidden source of sound. It is amazing with so different technique of voice production, that some patients have so perfected their oesophageal speech, that only a suspicion of hoarseness is noticed by the ordinary listener.

Thanks to these patients, it was not long before the value of this mode of speech for rehabilitation was discovered. (II. 1).

Oesophageal speech and ventriloquy are not infrequently mixed up, which is understandable because they are two unusual variants of normal speech. Ventriloquy is less strange than its name suggests. Speaking is done with the normal voice-mechanism. However, expiration is chiefly regulated with the abdomen, the thorax remaining fixed in inspiratory position. Everything is aimed at creating the impression that it is not the speaker who is speaking: the head-register is used, the bucco-pharyngeal cavity is reduced as much as possible and speech is being nasalized through an incomplete closure of the palate, all this in order to create a silly child's voice. Since nothing is allowed to be visible, articulation is bound to entirely take place inside the mouth. The slight radiation from the barely opened mouth renders it difficult to locate the sound. Histrionic talents and props, such as the dummy, must further serve to turn attention away from the speaker (data borrowed from HUIZINGA, 1931, LUCHSINGER, 1955 and our own examination of a ventriloquist in this town.)

4. For the purpose of obtaining a correct picture of the anatomical situation after laryngectomy, it is essential first to submit a sketchy description of the operation as carried out at Groningen. Under local anaesthesia a tracheotomy is performed, including the fissure of the thyroid isthmus. An intratracheal tube is then introduced into the trachea and through this the general anaesthetic is administered. The larynx is exposed, the vessels leading to it are ligatured and divided on each side. The pharynx is then opened above the hyoid bone, this being removed together with the larynx. The larynx is then separated from the hypopharynx and the oesophagus. When this is being done, the lower fibres of the inferior constrictor muscle of the pharynx, which are bundled into the cricopharyngeal muscle, are divided along the cricoid cartilage. The frontal wall of the pharynx, which has been removed in part, is

reconstructed by drawing together the remaining parts of the lateral wall. Both the cricopharyngeal muscles are stitched together in the median line so that a new sphincter is formed. The skin is then closed with the exception of the opening for drainage. Finally the upper end of the trachea is brought out at the neck and sutured to the skin of the former tracheostomy site.

5. The drawings 1a and b schematically show the change brought about in the situation by the operation. The air- and food-passages, which normally part at the larynx, are entirely separated now. The

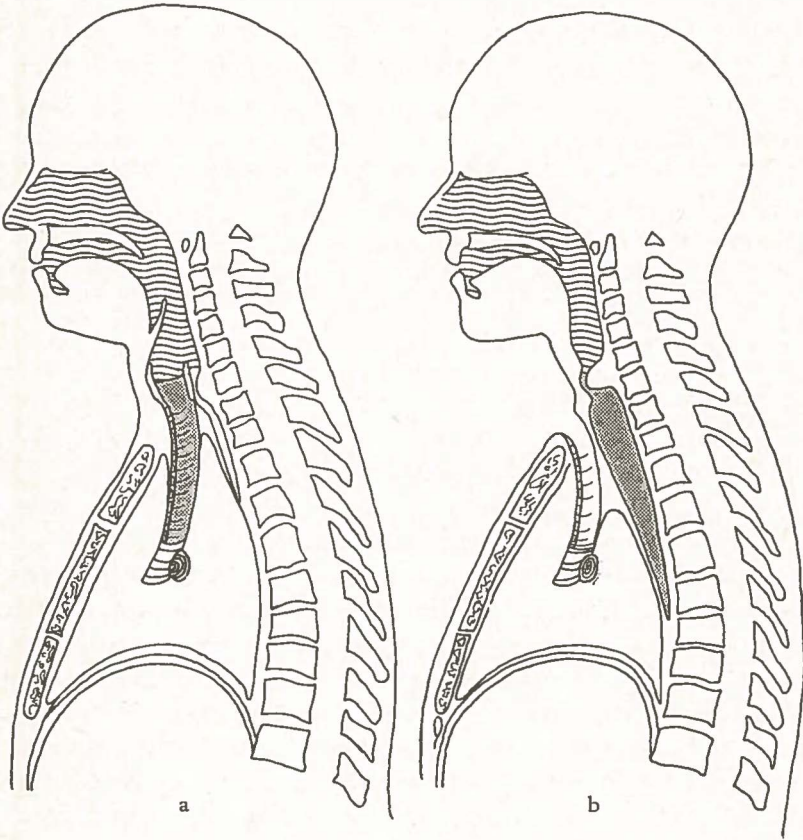

Fig. 1. Vocal tract. a) normal anatomy
b) oesophageal speech after laryngectomy. The pseudoglottis is the mouth of the oesophagus, constricted by the cricopharyngeal sphincter.

air-passage can no longer be closed off; this is no longer necessary for the deglutition. Yet this raises peculiar problems (VI). Further the pharynx has become a long, narrow funnel, which is especially clearly visible in the X-ray photographs (fig. 7). This funnel converges into the oesophageal mouth.

Let us now compare the physiology of the normal voice with the possibilities which the altered anatomical situation leaves for the formation of voice.

In the case of normal voice the air is pressed through the closed or narrowed glottis during expiration. The vocal cords are made to vibrate (V, 4), which results in the vibration of the air column in the pharynx and oral or nasal cavities. The resulting tone is very rich in overtones, especially in the chest-register. The cavities function as rapidly varying resonators. It depends on their volume and shape, which overtones of the original vibration will be amplified and which will be suppressed. Thus the composite sounds that are recognized as vowels and certain consonants by our sense of hearing, are formed. In the case of the voiceless consonants the vocal cords do not vibrate. Some of them are pronounced without the use of the respiratory air stream.

6. A man without a larynx no longer possesses vocal cords. However, this is not as important as it might appear as we know patients who, following extirpation of one vocal cord, do not make use of the remaining cord. They produce a hoarse, though serviceable voice by narrowing the laryngeal entrance, which, for instance, causes the ary-epiglottic fold to vibrate. In the same way the narrowing of the oesophageal mouth constitutes a satisfying substitute for the glottis. A much greater impediment is the absence of the air-current. Since the oesophagus can contain a small quantity of air only, constant replenishment is necessary. The way in which this is done is one of the principal elements in oesophageal speech (IV). Anticipating the discussion in section IV, we mention that there are two ways in which air can be taken into the oesophagus:

a. By suction. Inspiration increases the negative pressure in the oesophagus. By simultaneous relaxation of the oesophageal mouth the oesophagus fills with air.

b. By injection. This is done by compressing the air in the

pharynx with closed palate, the tongue and the bottom of the mouth acting as a piston. When the oesophageal sphincter is released, the air is allowed to escape into the oesophagus. This mechanism, which we have called the glossopharyngeal press, will be discussed in section IV. This injection bears a likeness to the first phase of swallowing, but does not follow the same reflex pattern.

c. Actual swallowing of air only occurs with beginners and then rarely.

Mrs. MOOLENAAR-BIJL, interpreting the self observations of a good oesophageal speaker, discovered that sentences with many plosive consonants were spoken more easily than sentences containing few plosives. She drew the conclusion that pronunciation of [p], [t], and [k] might play a part in the intake of air in the oesophagus. This has since been the basic principle on which all her subsequent patients have been treated. The rationale of her method is revealed in IV 3 and 5.

7. Despite the considerable knowledge already accumulated concerning the question of oesophageal speech many problems remain to be solved. Why is it, for instance, that some people can learn oesophageal speech quite easily, while there are others who are quite unable to learn the technique?

Our purpose has been to study the mechanism of oesophageal speech in detail in order to recognize the conditions leading to failure or to success and to improve the method of instruction.

Owing to the great value attached by Prof. E. HUIZINGA to the speech rehabilitation of his patients, a research program on this subject was instituted under the auspices of the Netherlands Health Organisation T.N.O., and under the direction of JW. VAN DEN BERG, D.Sc. This thesis is the result of the investigation.

SECTION II. HISTORICAL SURVEY

The interest in oesophageal speech is on the increase, which is connected with the increasing number of cases of larynx-extirpation. Nowadays it is preponderantly laryngectomy-patients that avail themselves of oesophageal speech. However, the first cases to be described, were those of patients suffering from obstruction of the larynx owing to trauma, and other causes.

In 1828 RAPRAND was the first to mention such a case before the Academie des Sciences de Paris (according to SCHÄR, cited by LUCHSINGER). Later on similar cases were described by CZERMAK (1859), SEILER (1888), and STOERK (1896).

Larynx-extirpation (because of syphilitic stenosis) is said to have been performed successfully for the first time in 1865 by WATSON in Edinburgh (LUCHSINGER). However, the patient died a few weeks later due to another cause. In 1873 BILLROTH had a more lasting success with his larynx-extirpation for cancer, which is therefore looked upon as the oldest case on record of larynx-extirpation.

Though this patient, and many following patients, were equipped with an artificial larynx, yet reports kept cropping up of patients who had learned to speak again spontaneously after the operation (POPPERT, 1893; SOLIS COHEN, 1893; GOTTSTEIN, 1900). These cases arrested great attention, and this not only as curiosities. The patient whom SCHMID (1889) discussed at a congress of surgeons in Vienna, was already held up by him as an example of speech-rehabilitation without an artificial larynx. At the same meeting LANDOIS and STRÜBING reported on their phonetical examination of this man. They thought that the pseudo-glottis was between the tongue and the palatal wall, but thought it well possible that the top part of the oesophagus served as an air-reservoir. In addition to the scientific side of the matter, they were also aware of the practical importance of speech-rehabilitation.

In the early part of the present century the Berlin surgeon TH. GLUCK developed an operation-technique that was largely imitated. He designed an artificial larynx, and, according to a quotation by BOTEY (1914) he also had an open eye for the importance of oesophageal speech. We read that the resonating cavities

are much more important for speech than the voice-generator and that pharyngeal voice might also be denoted as 'voix éructante'. In 1908 H. GUTZMANN surprised the laryngological world, gathered together at the first international congress in Vienna, with a series of 25 patients who had learned to speak again after larynx-extirpation. All the patients had been operated upon by GLUCK. This fertile combination of leading men in the fields of operation and voice-therapy, was responsible for it that both the therapy of vocal-cord carcinoma and voice-rehabilitation after laryngectomy were simultaneously greatly advanced.

Whether oesophageal speech or the artificial larynx is to be preferred is largely a matter of tradition, which differs from country to country. Unfortunately it is this tradition that is the cause that knowledge concerning oesophageal speech penetrates only with difficulty into those centres where an artificial larynx is the rule.

When in the twenties the science of phonetics was at its height in the West-European countries, there was also a great interest in oesophageal speech as a special case. In 1927 SCHILLING found, by means of pneumography and radioscopy, that displacement of air for the purpose of speaking is quite independent of the respiration. In our opinion he, just like other authors after him, goes too far, when he draws from this the conclusion that there is no co-ordination whatsoever between the two (VI). According to BURGER and KAISER this does not hold good for the expulsion of air during speech. In 1925 they published a detailed examination covering numerous accurate observations. It deals with a patient of 36 who had spontaneously learned oesophageal speech a few weeks after his operation. In 1956 when we met this patient, he still practised his profession of sports-reporter. One of the particulars mentioned about him is that he sucks on air with opened oesophageal mouth with the greatest of ease, and, in addition, presses on a further quantity of air by means of a movement resembling swallowing somewhat, yet differing from it.

VAN GILSE (1930) noticed with some patients that the first phase of the swallowing-process suffices to bring air into the oesophagus.

In those days radioscopy also began to take its place in phonetics. In the case of BURGER and KAISER's patient this was done by VOORHOEVE (1926). According to him the stomach functioned as an air-

reservoir during speaking, and the cardia can be opened and closed arbitrarily. At the time a violent discussion was going on between GUTZMANN and STERN whether the stomach really played a part in oesophageal speech (STERN's opinion) or not. For years contradictory observations and arguments were published. The question was finally solved by establishing that in beginners the stomach may occasionally co-operate, whereas in trained speakers it is only the oesophagus that fills with air (e.g. BECK, 1956).

STERN (1929) gives in his article in the *Handbuch* by DENKER and KAHLER a very extensive survey of all that was known at the time of oesophageal speech. Important contributions to his knowledge were supplied by STERN himself, but one is also surprised at the treasure of knowledge collected from the literature, and which, as appears from many later publications, has not become known sufficiently. KALLEN (1934) prepared an American version of the article in question.

In later years radiology was particularly used to locate the pseudo-glottis. It is generally found at the transition from hypopharynx to oesophagus. In his interesting publication on the cricopharyngeal fold, NEGUS (1938) mentions that this fold can function as a reed with laryngectomy-patients. MORRISON (1941) and MC CALL (1942) confirm this on the ground of their own observations. In this connection the investigations about the function of the cricopharyngeal muscle in normal persons (TEMPLETON and KREDELL, 1943; BRUNNER, 1952) are also of importance. LINDSAY and others (1944) give a detailed description of the behaviour of the cricopharyngeal muscle in oesophageal speech, illustrated by fine photographs. O. BRANKEL (1957) has had the original idea of rendering the vibrations of the pseudo glottis visible by means of stroboscopic radiology.

In 1951 NEUBERGER published his treatise on the psychology and sociology of laryngectomy-patients, a subject about which many authors have made observations, but which had not yet been investigated systematically.

Our insight into the mechanism of oesophageal speech was greatly widened by STETSON (1937). He stated precisely the "Pumpwerk" as found by SCHILLING and in his phonetic observations he gives useful practical indications, which are a revolutionary renewal as compared with the older notions.

BATEMAN (1952), too, arrives, by means of phonetic methods, at a clear representation of the mechanism of oesophageal speech. He points out the importance of an active control of the cricopharyngeal muscle and he imputes the high intrathoracic pressure he found during speaking, to the large effective resistance of the bronchioli.

In 1942 LUCHSINGER published a paper in which he gives, among other things, a report on his sound-spectrographical investigations.

MOOLENAAR-BIJL (1953) shows that the explosive consonants play an important part in the intake of air. On this she bases a new system of education, which makes the patient start straight away with the pronunciation of short words with initial explosives.

Since the number of centres where laryngectomy is performed, is constantly growing, there is an increase in interest in speech-rehabilitation. Therefore, the number of incidental publications that have appeared, particularly in the past ten years, is too large to be mentioned here one by one. All these publications are gratifying from the point of view of the dissemination of knowledge about oesophageal speech. For instance, PERELLO has largely contributed to the introduction of oesophageal speech in Spain, a country where the artificial larynx was much used.

Hardly any aspect of oesophageal speech has been left undiscussed. Time and again many discoveries about its mechanism were made anew. Hence it is that the systematical study by ROBE, MOORE, ANDREWS and HOLINGER (1956) is particularly worth mentioning; data obtained from the literature are confronted with their own investigations about the factors that affect the development of satisfactory speech after laryngectomy.

One constantly comes across contradictory opinions. Controversial points calling for elucidation, are especially:

- the way in which air is taken into the oesophagus;
- the optimal conditions for a pseudo-glottis;
- the expulsion of air during speech.

Therefore, these points will receive most attention in the present thesis.

SECTION III. EXPERIMENTS.

1. Plan of investigation.

At Groningen during the period 1942 to 1956 laryngectomy was performed on 55 patients by Professor EELCO HUIZINGA. A valuable and helpful factor in this investigation has been the continued close association of these patients with the clinic. Those living nearby continue to attend for regular checkups, while those coming from a distance have shown themselves quite willing to come for one or two days for our observation and to take part in our experiments. This enabled us to submit 25 persons to an extensive investigation. In addition another 20 persons were seen, who did not undergo the full examination. So as to be in a position to compare our results with those of other operating surgeons and speech-therapists an additional 24 patients were reviewed in Amsterdam and 8 patients at Utrecht. The patients of the Groningen clinic are numbered in Arabic figures, those of other clinics in Roman figures.

The general plan of the investigation was to collect meaningful data from each patient by means of interrogation, examination and experiments and relate them to the quality of his oesophageal speech.

The patients are divided into three rough groups depending on the quality of their oesophageal speech:

1. insufficient for practical purposes
2. serviceable speech, and
3. good or excellent speech

This rough division into groups was largely based on the subjective impression of the speech therapist and the author. Since the quality of speech is based on very different factors (purity of voice, intensity, velocity of speech, phrasing, voice-melody) these properties are occasionally compared separately and investigation of the special properties call for objective standards. By means of a tape recorder the following data were recorded concerning each patient:

1. detached, monosyllabic words with different vowels which were sustained as long as possible;
2. difficult words;

3. a standard sentence that was pronounced as quickly as possible, the time being measured in seconds;

4. highest and lowest obtainable pitch;

5. spontaneous speech in the form of conversation.

The sound-intensity was measured under standard conditions. This was done with a General Radio Sound-level meter type 1551-A placed at a distance of 50 cm from the patient's mouth in a sound-proof, anechoic room. We invariably worked with a flat characteristic and slow indication.

Data about the genesis of the voice and about the influential factors were obtained in the following way. An extract of the case-history further clarified by interrogation, supplied data on the extent of the operation, X-ray radiation, if any, post-operative complications, additional diseases, profession, habits of life. The impression gained of the personality during the interrogation and the experiments were likewise noted down. In the case of some patients the examination with the laryngoscope was supplemented by stroboscopy.

The following experiments were, as far as feasible, also carried out:

1. Simultaneous registration of the air-pressure in the pharynx, of the air-pressure in the oesophagus, and of the sound.

2. Measuring the tension of the oesophageal mouth-sphincter.

3. Fluoroscopy of the vocal tract during phonation and making X-ray photographs.

Special investigations made in the case of a few patients only are:

4. as under 1), combined with registration of the air-flow from the tracheostoma (III. 2, VI. 2).

5. as under 1), air-pressure in the pharynx being replaced by that in the trachea (VI. 2).

6. A cine-X-ray with synchronous sound, of the region of the pharynx, the pseudo-glottis, and the oesophagus (III. 5).

7. A cine-X-ray of the tracheal lumen. (VI. 2).

8. Sonograph analysis of voice recordings (V. 4).

2. Pressure recording along the vocal tract in oesophageal speech.

Aim.

To obtain an insight into the mechanics of oesophageal speech-production it is of great help to be able to see at a glance what is happening to the air-pressures in the mouth-pharynx cavity and the lumen of the oesophagus in time-relation to the sounds produced.

Recording-equipment.

Pressure-conduction by air took place along catheters of small bore (2 mm for the pharynx, 1.2 mm for the oesophagus) that were

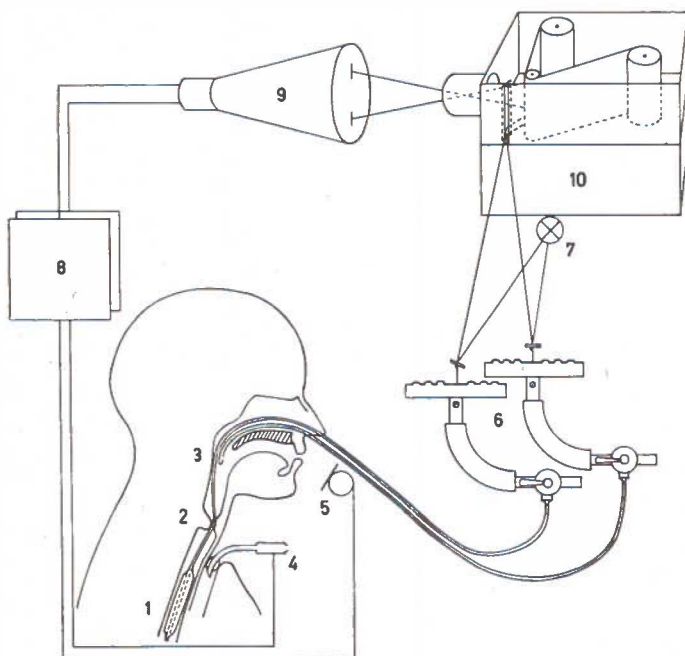

Fig. 2.

Diagram of experimental arrangement for recording pressure in pharynx and oesophagus, air-flow to and from the lungs, and sound.

- | | |
|-------------------------------------|-------------------------|
| 1. catheter in oesophagus | 6. optical manometers |
| 2. pseudoglottis | 7. source of light |
| 3. catheter in pharynx | 8. amplifiers |
| 4. tube in trachea, with flow-meter | 9. cathode ray tube |
| 5. microphone | 10. recording apparatus |

pliable enough not to interfere with the movement of the involved structures (soft palate, pseudo-glottis). To prevent closure of the catheter by mucus, air was blown repeatedly through the rubber catheter into the pharynx during the experiment. The catheter in the oesophagus was protected against the intrusion of moisture by a thinwalled (5μ) rubber condom about 11 cm long and 1 cm wide. The whole distal end of the catheter inside the condom, was perforated with holes on all sides. After inserting the catheter into the oesophagus 1.5 ml of air is injected into it before connecting it to the manometer. The catheters were kept as short as possible to minimize their resistance against quick changes in air-pressure. They were attached to optical manometers on a firm construction of interconnected bars mounted on a table thus eliminating distortion from movements of the head and vibrations.

After some preliminary experiments a suitable sensitivity was found to be approximately 1 cm to 30 cm of water. A membrane was accordingly selected. As the membrane was not yet sufficiently damped by the resistance of the polyethylene catheter, an adjustable damping-cock was added with which the system could be critically damped. The response-time was then less than $1/30$ of a second.

The light-beams reflected by the mirrors of the manometers were projected on to a moving photo-sensitive paper-strip. At the same time a sound-track is recorded on this strip by a cathode-ray tube. On top of this a time-signal supplied by the recording-apparatus itself indicates $1/50$ of a second. The speed used mostly was 10 cm per second. In one patient the air-flow to and from the tracheostoma was recorded with an electronical flowmeter, simultaneously with the sound- and pressure-recordings. The speed used there was 2.5 cm per second.

The patient is seated and the catheters are inserted through the nose. Sometimes a slight surface-anaesthesia of the nasal mucosa is required. Once in their place, they are fixed to the nose by adhesive tape and connected to the manometers. The patient is then in a position that he may speak easily with his mouth close to the microphone, so as to render the noise of the recording-machine relatively unimportant. The catheters were never a serious impediment to speech.

The pressure-curve of the oesophagus may be disturbed by a

peristaltic wave, that lasts for a few seconds, if the balloon at the tip of the catheter is filled with too much air. This does not occur, however, if only a few ml of air are injected, as only the stretching of the wall of the oesophagus gives rise to peristalsis.

A pneumocardiogram appeared sometimes on the records, but because it is easily recognizable and never amounts to anything compared to the pressures recorded in speaking, it does not cause much a disturbance.

Two basic forms can be distinguished in the records, displaying: 1) the injection-method, and 2) the suction-method of speaking.

This distinction refers to the different ways to take air into the oesophagus, as described in I. 6.

1. *The injection-type* (fig. 3a and d).

The lower line, representing air-pressure in the mesopharynx, runs a straight course for the most part. Only before each sound a steep elevation is seen that returns to zero level before the vowel (uppermost line) begins. The second line from the bottom, representing pressure in the lumen of the oesophagus, moves around zero level, diverging slightly above and below under the influence of respiratory phases, and sometimes modulated by the heart-beat. Only just before and while a sound is being made a positive pressure is seen. The curve starts rising when pharyngeal air-pressure has reached 18 cm of water; at this moment often a sharp kink occurs in the P-curve, indicating that the air flows off through the mouth of the oesophagus. The line of the rising air-pressure is then continued in the O-Curve. The O-curve reaches its highest point, equaling the pharyngeal air-pressure (0 cm of water), just before the sound begins. After that it slopes downwards or, after a initial lowering, rises again towards the end of the sound. This depends on the effort that is being made to sustain the sound. The recording of a sentence with many plosives (fig. 4) shows the frequent air-intakes coinciding with the 'holds' before the plosives. The air-flow curve shows a gradual expiration, interrupted twice by an inspiration.

In 23 out of the 24 patients of whom these registrations were made, this type of curve was found. We should like to emphasize this because of the important consequences resulting from this (Section IV). The tens of metres of registration-paper, which were accurately analyzed, all show a constant repetition of the pattern represented

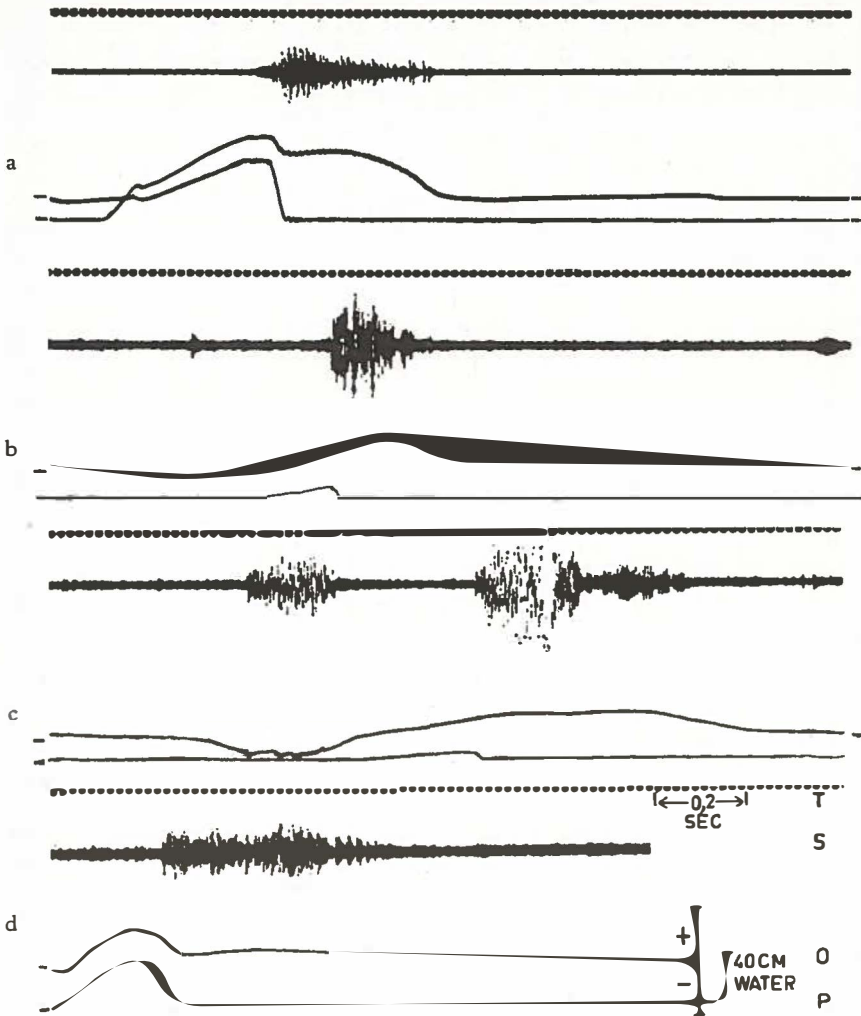

Fig. 3.

Simultaneous recordings of the pressure in the pharynx (P), the pressure in the oesophagus (O) and the sound pressure (S). Time signal (T) indicates 0.02 sec.

All four recordings (a—d) show pronunciation of the syllable [pa:].

a and d: injection method

b and c: suction method

a. patient (8); see explanation p. 16.

b. patient (26); note short sound during suction phase; [p] gives only slight rise in pharyngeal air pressure

c. patient (40); during speech rehabilitation; 'two-way' speech;

d. patient (40); three months later, after he had discovered the injection method (see text V.6).

We had in our series only one patient who habitually took air in by suction (26). The recording shown however is from patient (40), who temporarily used this method while being taught to change his formerly pharyngeal voice into oesophageal voice. After some months he switched over to the injection-method. (V. 6). For the rest we only saw this method applied by three patients that were operated elsewhere. One of them is a very good speaker: he is the patient that has been described by BURGER and KAISER as far back as 1925. Another patient (nr. II) is mentioned in V. 3.

When loud sounds are being emitted, we see from the curves that the oesophageal pressure can become from $1\frac{1}{2}$ to 2 times higher than in the event of normal intensity of sound. But also the pharyngeal pressure with which the air is injected, increases, mostly proportionately. From this we take it that, immediately after the injection of air, this high pressure is put to use: injection and phonation are, with a good speaker, hardly two separate phases, but rather one whole.

After air-injection, the remaining pressure in the pharynx may be used for the pronunciation of a subsequent plosive. If the syllable begins with a vowel the residual air-pressure is released without appreciable effect; sometimes, however, a faint plosive is audible before the onset of the vowel.

The time required for the intake of air is only small. We measured the time that elapsed between the beginning of the rise in pharyngeal pressure and the beginning of sound. Of each patient the average of four different places was taken. The lowest average was found with patient (7) with 0.12 sec., the highest (42) with 0.27 sec. As appears from the table (p.20) patient (7) can speak at great velocity, patient (42) cannot. The average of all the patients comes to 0.21 second. Further there is no clear relation between the time necessary to take in air and the velocity of speech. It stands to reason that the latter is dependent on more factors so that it is only in extreme cases that the influence of this one factor becomes clear. The intake of air by means of suction takes much more time than with the aid of injection. Patient (26) requires 0.6 sec. on an average for it (see also fig. 2 b).

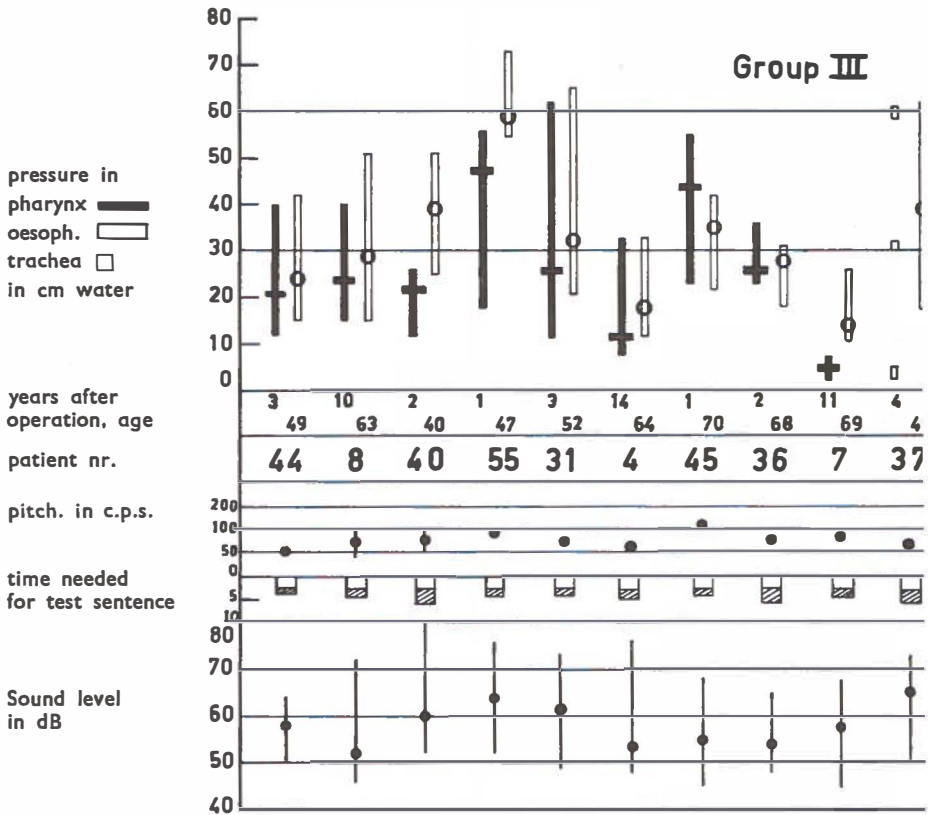

Fig. 5.

Table, presenting a survey of results of measurements on 25 patients, arranged from left to right in order of decreasing voice quality. From top to bottom:

1. pressure in pharynx; most frequently found value
- pressure in oesophagus; most frequently found value
- pressure in trachea
- (incidental measurements)
2. years after operation and age

3. Table.

The pressures measured of all the patients examined, are given in the table (fig. 5), together with some other measurable data: the frequency, the velocity of speech, and the sound-intensity. The full black line indicates the trajectory within which the highest points of the pharyngeal pressure (P-pressure) lie; the little square denotes the value found most frequently with the patient during

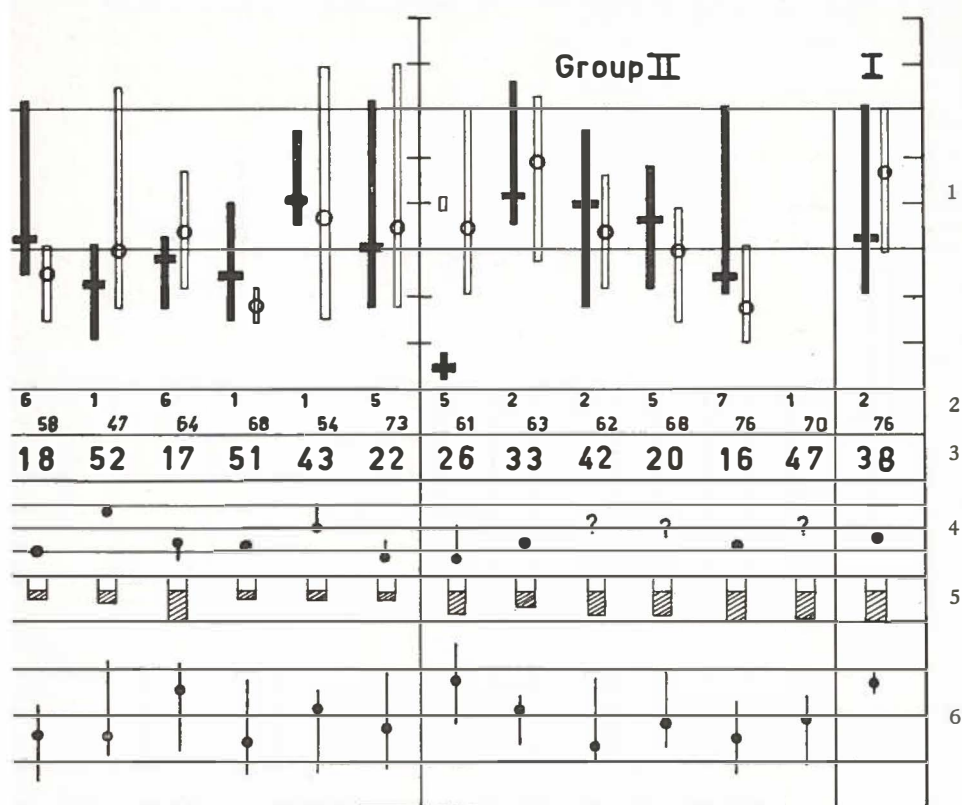

3. patients number (as used in the text)
4. ● usual pitch; | range of pitch
5. hatched: time exceeding the three seconds, needed by a normal person for pronouncing the test sentence.
6. sound level; ● in ordinary speech, | dynamic range.

air-injection. The hollow line is the trajectory of the pressures in the oesophagus (O-pressure) during phonation; the little circle denotes the value found most frequently with the patient. So the pressures in pharynx and oesophagus were not read at identical moments, since in that case the average P-pressure would be a little higher than the average O-pressure. The reason why the

table usually shows the reverse, is due to the fact that during phonation the O-pressure generally rises somewhat above its initial value.

The patients have been arranged according to the quality of their speech, special attention having been paid to the quality of the voice. The patients of group III (excellent and good speech) are separated by a vertical line from those of group II (serviceable speech). Of group I only a single patient allowed of registration. The remaining patients of group I are (39) who had a recurrence before he had learned to speak well, and (46) who will be discussed in IV. Of group II one patient (53) is not mentioned in the table. This patient could not start speech-therapy until two months after the operation owing to a disturbance in wound-healing. A few months later a recurrence set in.

Discussion

From the table few correlations appear between the quality of voice on the one hand and the measuring-results on the other hand. In the first place this is due to the fact that the measuring-results represent mean values over a certain length of time. Clear correlations might sooner be expected, if loudness, pitch and pressures would be taken at exactly the same moment.

More can be learned from the integral consideration of some patients separately. The purpose of the table is to allow the reader to look up in a convenient way some data about the patient under discussion. However, before starting the discussion of individual cases, we should like to deal with the global characteristics.

The most important find is that in nearly all the speakers there is a pre-phonatory phase in which the pharyngeal pressure runs to about 30 to 40 cm of water. This is about five times as high as the pressure during the hold in the articulation of plosives and twice as high as the highest pressure found in swallowing. A full explanation of this phenomenon is given in the next section (IV).

There is no relation between the number of years elapsed after the operation and the quality of the voice. It may be assumed that the conditions available for good oesophageal speech, are mostly realized in the first year. At any rate, this holds good for our patients, who invariably receive an active and usually very protracted speech-therapy. Patients (not represented in the table) who have

had to acquire oesophageal speech largely by themselves, tell us that they still perceive that progress is being made during the first two years.

There is some connection between age and speech-achievements. Age has certainly an adverse influence on oesophageal speech. Although not of preponderant importance, the impression is obtained that this factor will count above the ages of 60-65. There are many old patients among the poor speakers (to the right of the line).

It will be seen in the table that the poor speakers are specially characterized by a slow velocity of speech and an indefinite pitch. The sound-intensity is normal, in the case of patient (26) even very high. The other properties by which they might be judged poor, do not find expression in the table. The principal of these is the uncontrolled quality of the sound, hence the patient cannot use it sufficiently at will.

On comparing the group of good speakers, group III, it strikes us that the pressures registered in the pharynx and the oesophagus, are, on an average, a little higher in II and I, which points to an oesophageal sphincter that is none too supple. This is characteristic of beginners. With them we found, with a different method (III. 4), a higher tension of the sphincter, which used to drop with the acquirement of greater proficiency. Probably the inability to relax the sphincter is one of the causes that oesophageal speech does not become fluent.

We see that the average air-pressure in the oesophagus in good speakers is, in general, round about 30 cm water. However, this is not a rule without exceptions, as is witnessed by the patients (55) and (40), both of them highly remarkable cases, which will be discussed in detail later on (V. 5).

Both these patients could press air into the oesophagus with the greatest difficulty only because of an excessive tension of the *Musc. cricopharyngeus*. In (55) there was, in all probability, also an organic constriction of this sphincter. Owing to this they remained in the pharyngeal voice stage, which is a usual temporary stage in beginners. The pseudo-glottis was about on a level with the hyoid, the air-reservoir only consisted of the part of the pharynx lying below it. Special measures enabled us to teach these patients oesophageal speech. It is remarkable, indeed, that both these patients are now

among our best speakers. The pressure-recordings made shortly after this therapy, still show a high air-pressure in the oesophagus (for (55): 59 cm water). In this connection they are exceptions to the high pressures which are generally found in the bad speakers. It is possible that the high tension of the oesophageal mouth, which was an insuperable bar at first, contributed positively to the formation of a clear, powerful tone when it was better under control later on.

A very low P-pressure was found with (26); he is the only patient of our series that does not inject the air into the oesophagus but sucks it in. There is a clear reason why he must have recourse to this method: he has a palatal fissure so that he cannot close off his palate. This prevents his building up a high pressure in the pharynx because the air escapes through the nose. Hence the very low pharynx-pressures (5 cm on an average). These small increases in pressure are only found in his pronouncing plosives, they are not followed by a rise in the pressure in the oesophagus. Negative O-pressures of -10 to -14 cm water are measured instead between the words (fig. 3 b). At these moments air is sucked in. On expelling the air for phonation this man has not the advantage of the air being under high pressure, as is the case just after an injection. He must bring this about by means of an expiration-impulse. His speech is accompanied by a strong canula-noise. In addition, the course of the words is more strongly interrupted by the air-inhalations, which take more time than is necessary in the event of air-injection. All this results in halting speech, the velocity being very low.

The very low (5 cm) P-pressure also strikes us in the case of patient (7). Here however, the cause is different. With him also the oesophageal pressure is low (14 cm). In the registration of this patient we find, in a sentence containing few initial explosives, spots where the oesophageal pressure is strongly negative before the beginning of a word; it is obvious that air is being sucked in there. Yet the air is mostly taken in by injection. This is possible at such a low P-pressure because the mouth of the oesophagus is very lax (low O-pressure). Thus this man speaks very fluently, applying the two methods of air-intake promiscuously.

Conclusions.

These registrations give a clear picture of the mechanism that works in the production of oesophageal speech. With all the patients of our series except one the air was pressed into the oesophagus. The only exception was the patient with a palatal fissure, who took in air by suction.

A study of the data obtained in all patients undoubtedly emphasizes the importance of good control of the cricopharyngeal muscle, particularly regarding its relaxation.

4. Measuring the tension of the oesophagus-sphincter.

The previous experiment gives us an accurate picture of the course of the pressure in the vocal tract during speech.

The oesophageal pressure is already a measure for the tension of the oesophagus-sphincter. We have seen that in the case of two patients (40 and 55) who had an abnormal contraction and narrowing of this muscle respectively, far higher pressures were registered than are normally seen. This tension was in various other cases also measured separately. It is thus also possible to determine the achievements of patients who cannot speak, and also the extreme values of the tonus independently of speech.

Procedure

By way of the nose a catheter is introduced into the oesophagus until the tip is in the upper part of the oesophagus. This catheter should have a not too narrow bore, since it must be possible for a relatively large quantity of air to pass without noticeable resistance. This catheter is connected to a system consisting of a 50-ml syringe with branches, by means of T-parts, to the outside air and to a manometer. In the ducts valves are applied in such a way that alternatively air is sucked on from the outside and pressed into the oesophagus by moving the piston to and fro. During the injection the pressure can be read from the manometer. Meanwhile the air flows off through the mouth of the oesophagus. Since the latter has the greatest resistance in the system, it accounts for the prevailing pressure.

The patients are first asked to produce their normal oesophageal voice with the air that was injected. Next they are requested to

watch the manometer themselves and to try, by relaxation, to make the air escape at the lowest possible pressure. Finally they were requested to retain the air as long as feasible and make the pointer rise as high as possible. In this manner the normal pressure during speaking in the oesophagus and the extreme values were measured.

Results.

With some patients we performed the measurement at regular intervals as from the beginning of their speech-therapy. In the course of some weeks a decrease in the results was found. This points to an increasing ability of relaxing the *M. cricopharyngeus*. This is important in learning oesophageal speech, for, on the one hand, it facilitates the intake of air and, on the other hand, the outflow of air from the oesophagus. Both processes are essential for fluent and supple speech.

The results were, for each individual patient, varying. This is the reason why they were not embodied in the table.

With group III a pressure of round about 30 cm water was found during normal phonation. Nearly all these patients were, when asked, capable of letting the air escape through voluntary relaxation at a pressure of less than 10 cm, often noiselessly. However, most of them had difficulty in retaining, when asked, air in the oesophagus under high pressure. Of those who could, two (37, 55) have a wide loudness-range and one (43) has a wide pitch-range. The conclusion is obvious: satisfactory control of the sphincter-tonus offers the possibility of raising the intensity and pitch of the tone. This may be true, yet our two other loudness-champions both appeared unable to produce a high pressure (26,4). Their loud tone is due to a large volume of air that is expelled in an uneconomical way in a short time, which results in a great loudness of short duration.

Among the patients of groups II and I we do not find uniformity in the deviations from the norm (30 cm water).

Patients (38) and (42) have a high tonus, 70 and 100 cm water respectively. They are only capable of little variation of this pressure. Both have a high pitch which, as such, would lend itself well for an agreeable voice, were it not that they can only utter one or two syllables before a fresh injection of air is necessary. The poor control

of the cricopharyngeal muscle, makes that the latter is worse relaxed in the experimental situation than during speech.

The patients (40) and (55) had a persistent pharyngeal voice. (for definition see V. 2). Before they were cured of it, they had, in this experiment, very high pressures during the insufflation of the oesophagus. In the case of (40) it may be assumed that this was due to a reflex contraction of the oesophageal sphincter. In the case of (55) a rigid mouth of the oesophagus must have been an additional factor, since he has swallowing-complaints if he does not masticate his food very well.

5. A cineradiography with synchronous sound was part of our investigation-program; the subject was patient (8). *) The salient facts appearing from this film (described by V. D. BERG e.a., 1958) are the following:

a. A striking feature is that air is taken in extraordinarily frequently. During air-intake the pharynx widens and the mouth of the oesophagus sags. The small bulge that is, in some patients, seen at the front of the neck is in constant motion during speaking. It was formerly taken for the air-chamber that filled and emptied. However, this bulge is found to be above the pseudo-glottis. It is simply the weakest part of the pharyngeal front-wall that yields to the high pressure during the intake of air, and to a lesser degree also during phonation.

b. In the pictures of the bucco-pharyngeal region a great activity of the tongue and the soft palate are noticeable. The articulatory as well as the pumping movements are seen.

c. When the camera is turned towards the oesophagus, the phenomenon described by MOOLENAAR-BIJL in 1953 is seen: the oesophagus fills abruptly with air before the enunciation of a vowel and empties gradually during the enunciation. On the repetition of the syllable (ma) the oesophagus fills once and is already exhausted after two or three repetitions of the syllable. On the other hand, during a repetition of the syllable (pa) the oesophagus is seen to be replenished before each syllable so that it is never empty.

*) This film was made with the kind cooperation of N.V. Philips' Gloeilampenfabrieken, Eindhoven.

SECTION IV. THE INTAKE OF AIR

1. The way in which the air is taken into the oesophagus has already been touched upon in passing (I. 6). Almost all the patients examined by us pumped the air into the oesophagus under pressure; among the total number we found only five using the suction-method. Some of the patients applying this mode are discussed in III. 3 and V. 3. In the case of most of them some particular factor was present: the palatal fissure of patient (33), the absence of a normally shaped pseudo-glottis with II (see the X-ray photo in fig. 7b), and the fact that in the case of the third the operation was carried out in 1923 with a technique different from that applied nowadays. Therefore we are under the impression that the suction-method is exceptional and does not, in general, yield good results.

In various publications where air-aspiration is discussed, this should not be assumed to have the meaning of what we call the suction-method. It often appears from a further description that patients are concerned who apply the injection-method. This misunderstanding may have arisen in the following way. If the oesophagus was, on the X-ray screen, seen to fill suddenly with air, this created the impression as if the oesophagus sucked itself full of air. Air-injection looks exactly the same on the screen, however. On the strength of radioscopy alone it is impossible to conclude whether air is sucked on or injected.

Likewise the term *inhalation* calls, in our opinion, for a prudent and not too literal interpretation. It is sometimes mentioned to denote the quality of a speaker that he is capable of counting up to, for instance, 20 after a single inhalation of air into the oesophagus (e.g. FROESCHELS, 1951). It seems likely to us that such a patient would be exposed by the registration described in the preceding section. For after a single detached intake of air before speaking the air-contents in the oesophagus are every now and then, almost imperceptibly, replenished. The series of syllables is limited only because the speaker has to take a new breath. Fluency of speech is rather promoted than hampered by frequent air-injections (STETSON, 1937). We have been in a position to establish that of those who had

had no instruction in oesophageal speech, the best speakers had arrived at the injection-method spontaneously.

So we want to postulate that this is the normal method that should be aimed at in voice-education. Since the application of this method is sometimes attended with difficulties, we shall now scrutinize the mechanism of air-injection.

2. The pressure-recordings show that the pressure applied during the intake of air are in the neighbourhood of 20–30 cm water, with a maximum of 65 cm.

The pressures found by BECK (1956) were even higher: 67 mm Hg in the nose, 131 mm Hg in the oral cavity. Though it is not distinctly specified what purpose was served by these incredibly high pressures in Beck's patients nor how they were measured, we do not wish to deny the possibility of such high pressures being obtained.

The way in which a high pharyngeal air-pressure is build up, can be demonstrated by inflating a manometer, e.g. that of a blood-pressure meter, through a tube held in the mouth, its tip lying in the pharynx. The pressure is then obtained by closing the glottis, the palate, and the mouth (either by the lips or the tongue) and compressing the air thus trapped in the pharynx by an upward and backward movement of the tongue. We call this mechanism the *glossopharyngeal press* or – pump, depending on whether the air is mainly compressed or displaced. It appears to serve in the injection of air in speech of laryngectomized patients and can replace the expiration-pressure for various purposes (IV. 3).

In normal persons, too, there are still other functions in which the glossopharyngeal press is of use (fig. 6 nrs. 2 and 3).

a. During the (modified) *Valsalva*-manoeuvre the palate is relaxed and the nose pinched so as to press air through the Eustachean tube into the tympanic cavity.

b. In the pronunciation of voiceless, non-aspirated *plosives*, the glottis is closed and phonation suspended, pharyngeal air-pressure holding the subglottic air-pressure in check, until it is released. (GRAMMONT, 1946).

c. As additional illustrations several trivial actions in everyday life may be mentioned, such as spitting, smoking in the case of non-inhalers (here the accent rather lies on the suction-phase of

the glossopharyngeal pump) etc. The importance of these things becomes apparent only if one can no longer perform them, as in the event of a paralyzed or defective palate, or if, and this is particularly important in our case, one can seize upon these trivial habits during the re-education of speech after laryngectomy.

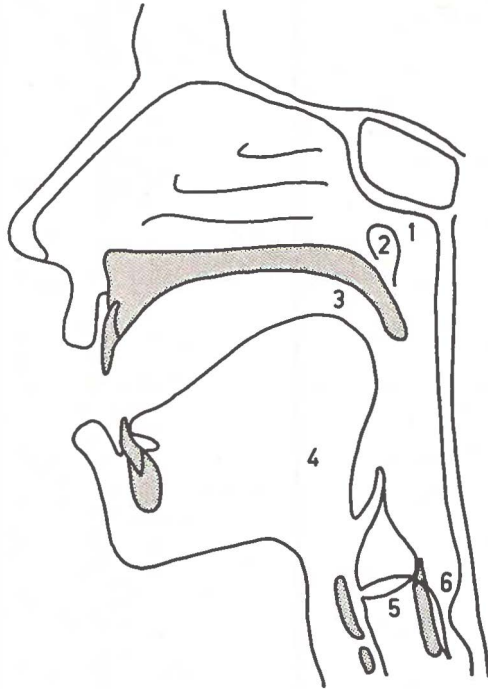

Fig. 6.

The glosso-pharyngeal pump mechanism is active in:

1. smelling and blowing the nose by laryngectomized
2. modified Valsalva manoeuvre
3. articulation of plosives
4. frogs' speech
5. glosso-pharyngeal breathing
6. air injection in oesophageal speech

See text Section IV and V.5.

3. Thus we see that in everyday life of normal people the glosso-pharyngeal press plays a diligent, be it inconspicuous part. Nobody is aware of its existence, even less than of the existence of the abdominal press. Just as it may be useful to explain to a woman

before childbirth the mechanism of the abdominal press in order to prevent inco-ordinated muscular tensions, so it is sometimes useful to make a laryngectomy-patient aware of the glossopharyngeal press. For its importance only comes to the fore when the normal path for respiration is obstructed, and the pulmonary air stream and pressure have no access to the bucco-pharyngeal cavity.

The glossopharyngeal press then serves:

- a. for smelling and blowing the nose;
- b. for the air-pressures and air-currents required for pseudo-whispered voice;
- c. in frog's speech to press the air along a palatine arch, by which the air is brought into vibration (fig. 6 nr. 4); a case in point is described in V. 6;
- d. for the injection of air into the oesophagus, when the mouth and the palate are closed off and the oesophagus-sphincter is relaxed.

The latter is the usual manner in which oesophageal speakers take in air for phonation. After the preceding explanation it is clear that the manoeuvre is not so foreign to our normal physiological functions as is often thought.

How indispensable this pumping-action of the pharynx is, is clearly shown by patients with a pharyngostoma. They can neither learn oesophageal speech, nor articulate plosive consonants when using an artificial larynx, nor produce an effective pseudo-whispered speech. All because there is a leak in the glossopharyngeal press. (VIII. 4).

4. So as to be able to compare the air-injection with swallowing, we made a cineradiography of patient (44) during phonation as well as during swallowing. The speed amounted to 48 pictures a second, so that it was possible to project in slow motion. The scene was cut out and the ends of this strip of film were connected so that the scene could be projected endlessly. The initial stage of swallowing appeared to correspond largely with the manoeuvre for the injection of air. However, the forceful closure of the palate, which is essential for the latter, is sometimes absent in swallowing, dependent upon what is swallowed and how quickly it is done. The back of the tongue is seen to descend farther downward in preparation for an

air-injection than in swallowing, and need not touch the palate as in swallowing. Furthermore the co-ordination and the timing of the onset of action of the various groups of muscles is different. In particular the reflex-opening of the cricopharyngeal sphincter that happens in swallowing solids or fluids fails to appear in air-injection. A new reflex-path has to be created during the training-period (IV.6).

5. This explains the fact that causing air to be swallowed is not the shortest cut to teaching a patient oesophageal speech. What he should learn, the injection of air, is not so simple to explain to him. But explaining is not necessary, as there are several expedients to guide him, practising all the time, along the right road, viz.:

a. Making use of the high pressure built up in the pharynx before pronouncing voiceless plosives. The patient is asked to articulate forcefully the monosyllables pa, ta, and ka. At first the patient will not yet get the idea of relaxing the mouth of the oesophagus, and in this way a pharynx-voice is created. In practising further with words like cartoon, pertain, pontoon, etc. the air is soon pressed on deeper, and after some days oesophageal sound is formed. This sound is developed under the encouragement of the speech-therapist. This is the usual technique which has been successfully applied to the patients of the Groningen clinic for many years already.

b. If it is thought fit to pay extra attention to the injection of air, the patient may be made to practise by inflating a manometer.

c. Another exercise consists in blowing and sucking through the nose as large a quantity of air as possible. If the patient does so whilst pinching his nose, he is bound to feel the pressure in the ears. The progress made can also be examined well by causing the patient to make a snorting sound with his palate. FROESCHELS has already described this in 1928.

6. Before acquiring oesophageal speech the patient has to cross the barrier caused by the tension of the *cricopharyngeal muscle*. In normal people this muscle is reflex-controlled. It serves as a sphincter to close the mouth of the oesophagus against the penetration of air in the oesophagus due to variations of pressure during respiration (NEGUS).

This reflex chiefly comes into operation when air-pressure in the pharynx is high, as in sneezing, playing wind-instruments, and during the formation of explosives and sibilants. The Valsalva test is a good experimental imitation of these conditions. The contraction of the cricopharyngeal muscle in the Valsalva test has been demonstrated radiologically (NEGUS, 1938; CLERF and PUTNEY, 1942; BRUNNER, 1952). The relaxation of the cricopharyngeal muscle under the circumstances is consequently a perfectly unnatural act. And it is precisely this the laryngectomy-patient has to learn, if he is not to remain with a pharyngeal voice.

If some time has elapsed before the teaching of oesophageal speech, it is often seen, particularly in energetic patients, that they have already developed the habit of pseudo-whispered speech. The sharp articulation requiring high pressures has further established the habit of keeping the cricopharyngeal muscle tightly closed, and so it is much more difficult than is normally the case to overcome this reflex-conditioned contraction.

Quite exceptionally the plosive-consonant method may also lead to this. The speech therapist should take prompt action if the patient threatens to persist in a pharyngeal voice in the early stage of speech-rehabilitation. Mostly this can be counteracted adequately by clearly telling the patient not to be satisfied with his voice. As soon as the mere embryo of oesophagus-sound is heard, this should be loudly applauded and developed further. This requires great attentiveness and a critical ear from the speech-therapist.

If oesophageal sound is not produced at all, which seldom occurs it is better to suspend the exercises in powerful articulation for the time being, because the patient evidently cannot help constricting his pharyngeal muscles. We then have recourse to air-insufflations into the oesophagus. This practice has already been recommended by various authors (BOTEY, 1914; GATEWOOD, 1946; SEEMANN, 1951). We always use the apparatus described in III.4 so as to be able at the same time to read the pressure in the oesophagus during phonation. By watching the manometer, too, the patient may be consciously led to relaxing his oesophageal sphincter.

There is still another exercise to which we subject the patient, if oesophagus-sound fails to present itself quickly. Before beginning speech-therapy the patients are asked to try and belch. Most of

them are unable to do so, which is intelligible, since the air-passage is in open connection with the outside air. Thus a negative pressure in the thorax can be made less easily than by normal persons who can close their glottis. If after an expiration one closes the tracheostoma with a thumb, the patient will mostly succeed; he must inspire strongly, yawning at the same time and bringing forward the lower jaw. This helps in widening the pharynx and making the *M. cricopharyngeus* yawn. If one succeeds in thus obtaining a good sound this will greatly encourage the patient. The exercise is continued for some days until the air can easily pass the pseudo-glottis up and down. The sole purpose aimed at is to teach the patient to feel the correct tension-balance of the pharyngeal muscles and the oesophagus-sphincter required for good oesophageal sound. The ultimate goal is to make the patient give up this way of sucking on air and learn the method of air-injection instead.

If these measures fail to produce a permanent effect, the region of the neck must be X-rayed and photographed to establish anatomical particularities. If it is found during air-insufflation that the air escapes through the pseudo-glottis at a particularly high pressure, it is likely that there is either a stenosis or an inveterate reflex-contraction of the oesophageal mouth. In either case it is possible to get out of the impasse by making the patient swallow a thick oesophageal dilatator before subjecting him to the above mentioned exercises. The cases in which we did this first, are described in V. 6.

7. Likewise in Section V you will find a case of obstruction of the larynx. This patient did not use oesophageal speech, but had acquired some sort of frog's speech. With Mrs MOOLENAAR-BIJL we described this patient (1958) and we termed his speech glossopharyngeal speech. In the first place because the pseudo-glottis was formed by the tongue and the left palatine arches and in the second place because the air was pressed through this pseudo-glottis with what we had already called the glossopharyngeal press.

This name was chosen on analogy of the glossopharyngeal breathing or frog's breathing. This is a technique enabling patients afflicted with respiratory paralysis and an insufficient vital capacity, to maintain themselves outside the respirator. This invention is but a few years old (first described by DALL 1951). The technique is quite

the same as that for air-injection in oesophageal speech, only the mouth of the oesophagus remains closed, the air being pressed into the trachea. After ten or twenty 'piston-strokes' the lungs are filled. Then the patient must slowly empty the lungs and start filling up again.

It is of importance to recognize the common pumping-mechanism of these seemingly entirely different rehabilitation-techniques. Some tricks (IV.5) applied in teaching the mastery of air-injection in oesophageal speech, may likewise be employed in teaching glosopharyngeal breathing.

Historical note.

In the relative literature we come, time and again, across observations belonging to the injection-phenomenon without being recognized as such. For instance, BANDLER (1888) mentions that explosives are pronounced more easily and that m is changed into b, n into d in oesophageal speech. By covering the tongue with carmine, he established that the former does not touch the palate. According to a quotation by BOTEY (1914) GLUCK makes his patients start with words beginning with p, b, and v, having these plosives articulated very strongly. NADOLECZNY used to begin with initial plosives (cited by BERING LIISBERG, 1943). According to GUTZMANN an early result is obtained by repetitions of 'kit-aa', STERN prefers 'kisté'.

Some authors give a description of the pump-mechanism in air-injection (SCHILLING, 1927; STETSON, 1937; MOORE, 1948; MARLAND, 1949; BATEMAN, 1952; POMMEZ, 1952; MOOLENAAR-BIJL, 1953). The connection between the pronunciation of explosive consonants and the intake of air, which was stated by STETSON, was noticed by MOOLENAAR-BIJL in one of her patients, and used as a basis for a new system of education. In this system the injection-method is aimed at by having the patients strongly articulate initial plosives from the very beginning.

SECTION V. THE PSEUDO-GLOTTIS

1. A large number of places in the alimentary tract, where air can be pressed through a constriction, were formerly looked upon as possible locations of a pseudo-glottis. They were:

- folds in the wall of the oesophagus, especially in the presence of stenosis or spasms (СТУПКА, 1921),
- the mouth of the oesophagus,
- folds of the mucous membrane in the hypopharynx,
- the constriction that may arise between the tongue and the back of the pharynx, the tongue and the palate or the palatine arches.

Practice teaches us that several of these possibilities are of rare occurrence. In the great majority of cases (37 out of the 41) it was the mouth of the oesophagus where the air was made to vibrate. Only in rare instances have we seen the other possibilities. These will be mentioned at the end of this section (V. 6).

As a matter of fact, it is quite possible that formerly there were more exceptions to this rule, because of un-standardized operative techniques. Since the part played by the cricopharyngeal muscle has become known, more attention is paid to sparing this muscle and to suturing it carefully. Formerly the operation was carried out in two stages (with secondary closure of the pharynx); wound-supuration and formation of scar-tissue must have been worse than it is now. Owing to this and similar causes anatomical conditions may have greatly varied from case to case. One was therefore compelled to wait and see where the pseudo-glottis would form spontaneously. However, we are not satisfied until we have taught the patient to use his oesophageal mouth as a voice generator. Even in an unfavourable case like that described by DORNHORST and NEGUS (1954), where along with the larynx the upper portion of the oesophagus had to be removed, the pseudo-glottis arose at the junction of the skin-tube and the pharynx, by contraction of the remaining fibres of the pharyngeal constrictor-muscle.

2. It is understandable that, at a time when investigators are uncertain as to the place of origin of the voice, they are vague in giving names to this sort of speech. Hence we have: pseudo-voice

and pharyngeal voice (LANDOIS, GUTZMANN, STERN); KALLEN proposed alaryngeal voice. In 1919 SEEMAN had purposely developed the oesophagus as a speech-organ in a female patient, and coined the phrase 'oesophageal speech'. For some time thereafter oesophageal speech was regarded with suspicion; it was thought to be a special technique different from the usual pharyngeal speech and considerably more difficult. Gradually the name has become universally accepted. One must realize that most of the voices formerly called pharyngeal, would be called oesophageal today, the phrase pharyngeal voice having been set aside to indicate a special type of voice.

Still the use of the term pharyngeal voice in the obsolete sense persists till the present day, causing an unnecessary confusion. This name is then defended for the reason that the cricopharyngeal sphincter is a pharynx-muscle (MARLAND). We use the name only as a specific term to describe a special voice that, contrary to oesophageal voice, is generated high in the pharynx, the airstream being derived from a small bubble of air low in the pharynx where it is compressed without passing through the mouth of the oesophagus. This pharyngeal voice may be normal in beginners as a transitory phase, but if this stage is not overcome, we consider it as pathological (patient no. 40).

As an example of a confused notion, resulting in erroneous terminology, we give a quotation from one recent article (1956):

'This leaves him (the patient) the choice of two alternatives: the oesophageal and the pharyngeal methods of speech. The oesophageal voice requires him to be able to swallow large amounts of air . . . The oesophageal voice, too, makes necessary frequent interruptions for the speaker to replenish his supply of intragastric air; he cannot speak his words trippingly on the tongue.

Though admittedly the pharyngeal voice is the hardest to master, it is by fair the most satisfactory, . . . the sound is more natural than the other types, and there is nothing inelegant or offensive to the innocent bystander about it. With practice in deep breathing, the accessory muscles of respiration, necessary for him to get air into his pharynx, are strengthened, and deep breathing exercises should be continued.'

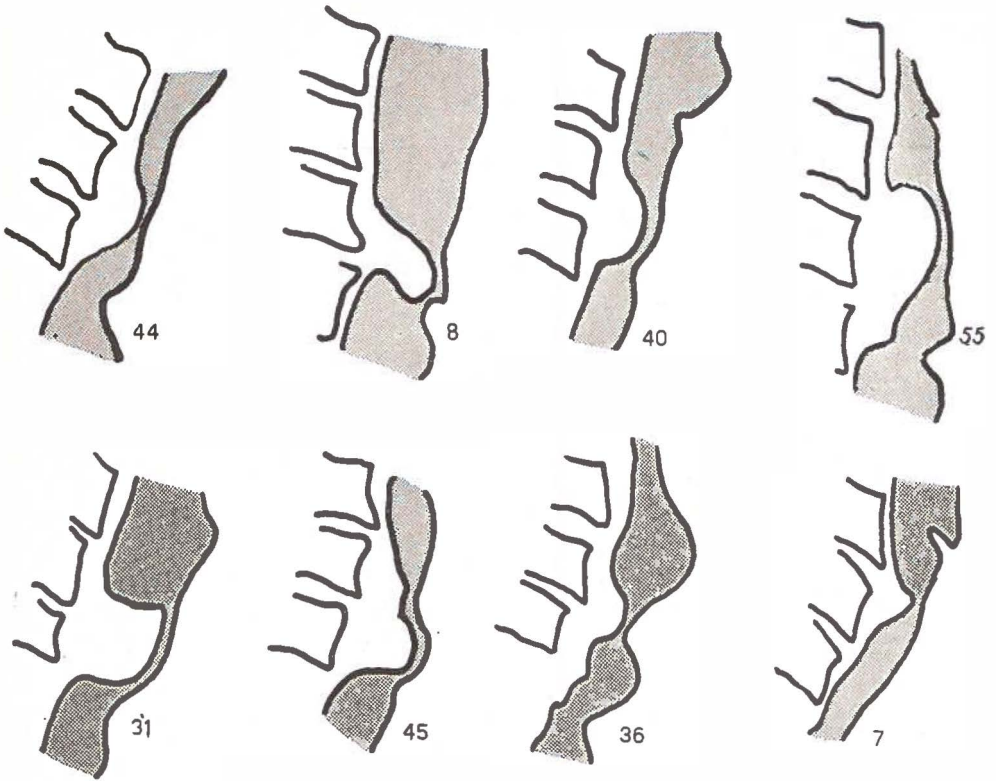

Fig. 8a. Tracings of the radiographs of fig. 7. For orientation only the 4th, 5th and 6th cervical vertebrae are shown in each patient.

a. good voices

By this 'pharyngeal voice', in which 'the patient speaks his words trippingly on the tongue', is probably meant the type of oesophageal speech in which the injection-method is used. 'The accessory muscles of respiration' supplies an incomplete indication of what we call glossopharyngeal press. By oesophageal speech the writer alludes to that method according to which air is actually swallowed or sucked in. This method is also disapproved by us, but there is no reason whatever to call this, of all things, oesophageal speech.

3. X-ray examination.

Nearly all the patients of our series were subjected to X-ray examination. For contrast a bismuth-paste was used which was

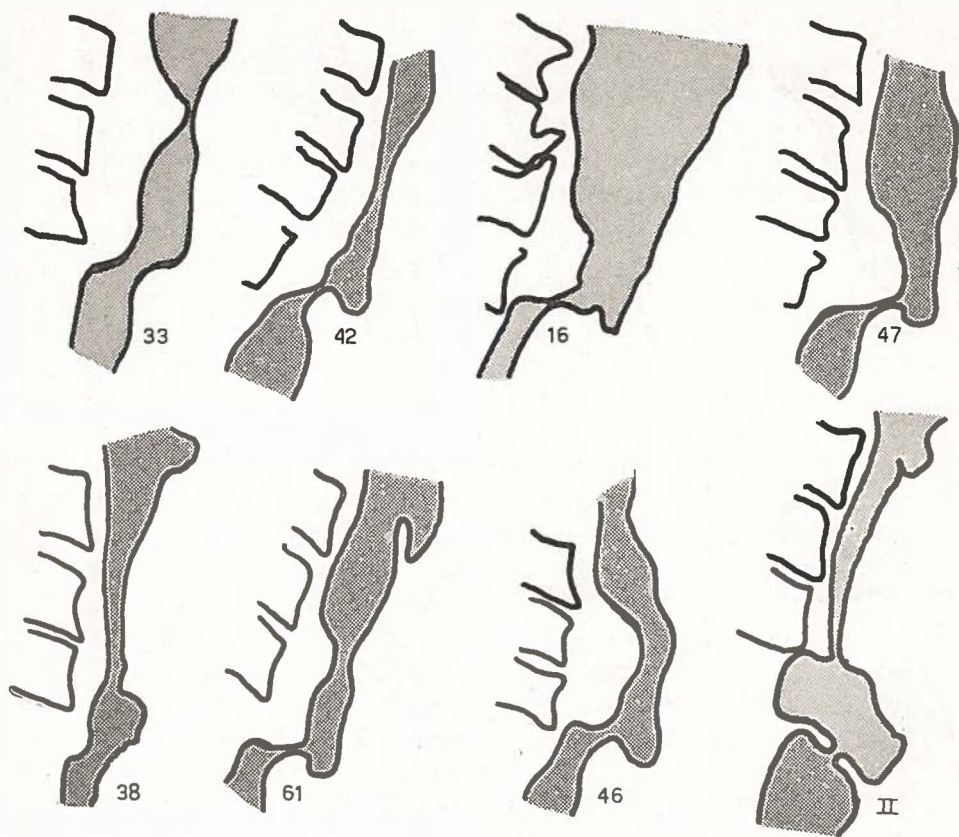

Fig. 8b. bad voices

made sticky by adding gum arabic. This was swallowed under lateral fluoroscopy of the neck-region. Next the neck-region, the mesopharynx and the oesophagus were watched during speaking. In this way one is informed of:

the place and the shape of the pseudo-glottis;

the activities of the tongue, the palate and the pharynx during the intake of air;

that part of the oesophagus that fills with air, and the frequency at which the oesophagus refills.

In this examination the Philips X-ray intensifier has always been of great advantage to us. It is particularly suited for such pho-

netical observations. The advantage is that an extraordinary clear image is obtained with a lower X-ray dose than is used in normal fluoroscopy. Therefore, adaptation to darkness is unnecessary and one sees normally with one's foveal vision. Hence it is that small details and rapid movements can be seen better than it is possible with an organ of sight adapted to darkness. In addition, owing to the low X-ray dose there is less necessity of hurrying up the examination.

Next a radiograph was made of the region of the pseudo-glottis, i.e. mostly a lateral neck-photo. This was not done under fluoroscopy, but with a greater distance from focus to object. The photo's made in this manner were sharper and of better contrast. A few X-ray photo's were made during fluoroscopy with a serial changer; they are seen on a somewhat larger scale in fig. 7. After some experiments it appeared that lateral tomograms of this region are of no use. The use of a contrast medium yields a nicer outline of the lumen.

The pseudo-glottis is defined as the most cranial narrowing in the lumen of the oesophagus or of the pharynx over which the contrast medium is seen vibrating. The latter is essential for it not infrequently happens that a constriction is seen to arise in various places either simultaneously or successively. Generally these places are respectively the mouth of the oesophagus and a fold in the pharynx on a level with the hyoid bone. It is particularly in beginners that this is often seen. Then one also hears the high pharyngeal character of the voice alternating with the full oesophageal sound.

One patient has never got rid of this phenomenon (fig. 7) When he is in good voice the mouth of the oesophagus functions as pseudo-glottis, the hypopharynx not being contracted. However he is often handicapped by mucus, and then the pseudo-glottis goes one floor up. However, the oesophagus then still serves as an air-reservoir, this in contrast with the pharyngeal voice proper, as described in V.2, where the air-reservoir is confined to the hypopharynx over the mouth of the oesophagus (patient no. 40, fig. 1). The sound quality deteriorates when he speaks with his high pseudo-glottis, but the sounds can be sustained long enough. His sentences are not spoken with staccato-like interruptions as was the case in patient no. 40.

Fig. 7.
Lateral radiographs
of the neck; region
of pseudo-glottis,
during phonation.
a. Patients with
good voices

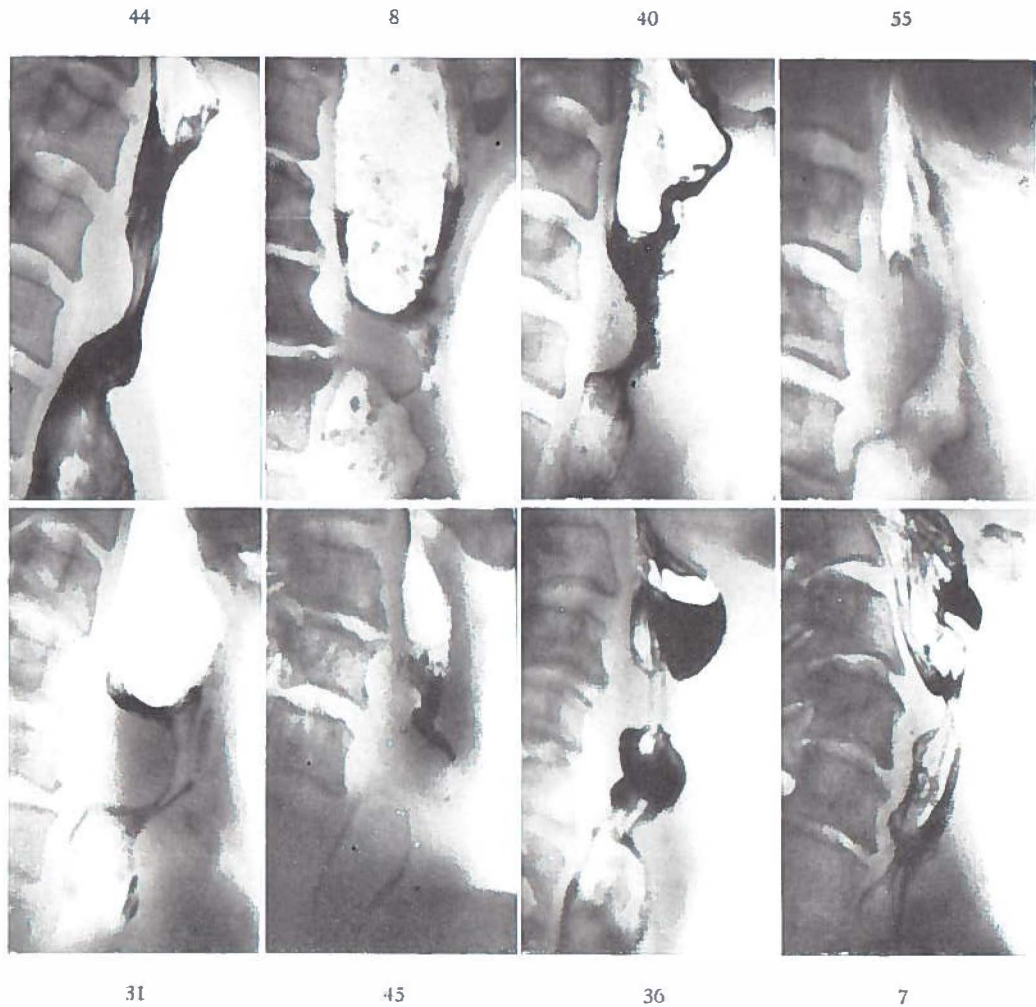

b. Patients with poor voices. Five patients show a pouch in the anterior pharyngeal wall with accumulation of mucus.
See text V.3., p. 39

33



42



16



47



38



61



46



II



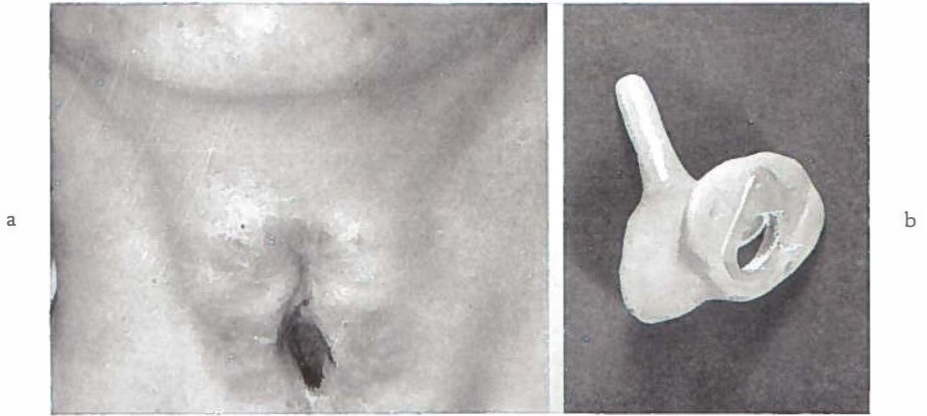

Fig. 13.

- a. Tracheostoma of patient with laryngeal obstruction. External orifice of fistula leading to hypopharynx can be seen in the upper part of the stoma.
- b. Acrylic prosthesis enabling this patient to use the fistula as a voice organ (see fig. 14b).

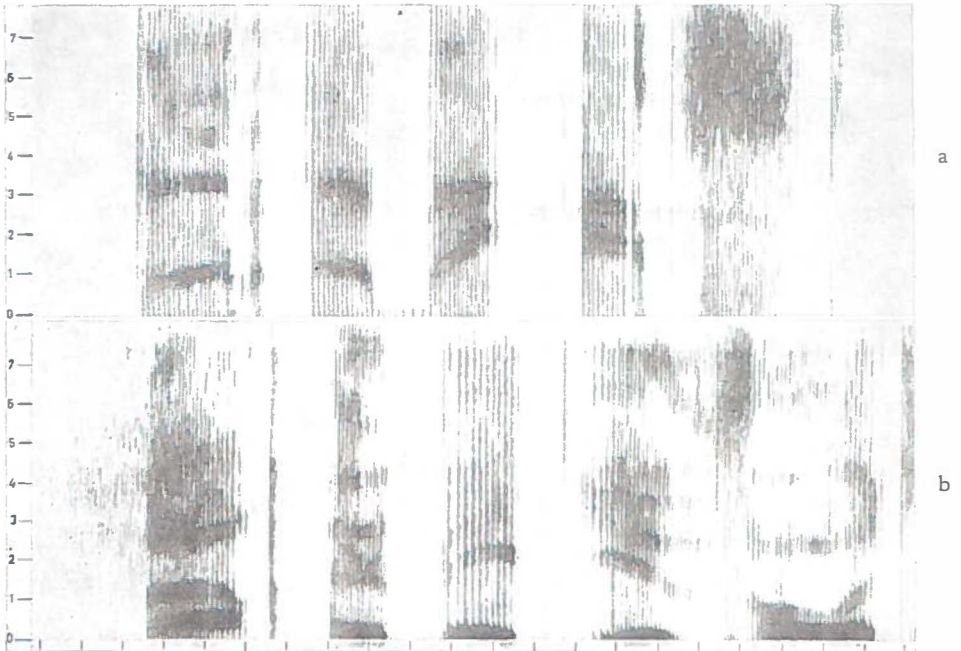

Fig. 14.

- Sonograms of patient from fig. 13. The same sentence is spoken as in fig. 10.
- a. Frog's speech b. voice with prosthesis.

The shape of the pseudo-glottis is fully determined by the M. cricopharyngeus, by the way it restricts the lumen at the transition of the oesophagus into the pharynx. The radiographs of eight good speakers (compare group III from tabel) are put side by side in fig. 7 and opposite the radiographs of eight less good speakers (most of them from group II). All these X-rays were made during phonation. It should be borne in mind that they are instantaneous photos and that the shape may change in the course of a sound, as can be seen during fluoroscopy. Hence it is that the degree to which the oesophagus is filled with air, varies. However, the main features remain the same. The differences that are visible, are thus not due to the casual moment of exposure, but are really the marked differences between the various individuals.

So as to bring out the outline of the oesophageal lumen more markedly than in the X-ray prints, we have traced it and shown it in fig. 8. For guiding purposes we have each time represented the fourth, fifth, and sixth cervical vertebrae.

The prominence formed by the cricopharyngeal muscle is, in most cases, before the fifth and sixth cervical vertebrae, in poor speakers often lower. In good speakers its shape is fairly regular, at any rate less indefinite than in poor speakers.

An important characteristic of group II is the formation of a bulge in the ventral side of the pseudo-glottis, in which secretions easily accumulate (patients no. 42, 16 47, 61, 46). All these patients show a common characteristic in their voice too: it has a bubbling, mucous sound. This is explained by the fact that, after being pressed through the narrowing, the air must pass through a layer of mucous secretions.

Accidentally we got an indication of a possible genesis of this bulge. Patient (55), who is discussed in detail in V.6, at first had difficulties during speech therapy. Therefore X-ray photo's of the cervical region were already made in a very early stage (fig. 9a). It appeared that the contrast medium had got into the soft parts before the pharynx just above the tracheostoma. So there was a blind ending fistula of the front wall. Speech therapy was then stopped and resumed a few months later. When the result was good, photos were made again. A bulge is clearly visible in the front-wall; presumably this is all that is left of the fistula. The man was in

luck, for this bulge is below the level of the pseudo-glottis. It can only be a nuisance if the constriction where the voice is generated, is not just above it but just below. This can be seen best by comparing (55) with (47) and (61). The last two patients have almost the same anatomy as (55), but they use the lower lip of the fistula as pseudo-glottis and this makes all the difference for their voice. One wonders if, especially in (61), it would not be possible to obtain the same functional result as in (55), for instance by dilatation. (IV.6; V.6).

(46) Is a picture that draws the attention by showing a favourable configuration as compared to the other poor speakers. But here is a different cause for the poor performance. It is the radiograph of a female patient who was extremely difficult to teach. A qualified speech therapist did her best with her, but practically without result. Later on she appeared to have a heavy perception deafness.

The photo next to it (II) is likewise a case with a pathetic feature. It is that of a man who thinks his speech may stand as an example for all other patients. He speaks by means of the suction-method (IV.1) and the noise from the canula drowns his speech, just like the roaring surf drowns the call of a sandpiper. He is quite unaware of this noise because of a beneficial discant deafness.

4. Acoustic properties of the pseudo-glottis.

The fundamental tone of an oesophageal voice is often difficult to determine. This is because the frequency is low and because the sound is very complex, in other words the fundamental tone is accompanied by a large number of relatively strong overtones. The ear is not very sensitive in the frequency-range of the fundamental, much more sensitive in the range of the partials. And the latter contain a large part of the total sound-energy.

SCHOUTEN (1940) has shown that the perception of the fundamental frequency of a sharp tone is based on the collective perception of the high harmonics (the residue), on the periodicity of the common vibrationform of these harmonics (this periodicity can be seen in the sonograph-analysis). It seems probable that the presence of partials up to about the tenth facilitates perception of the fundamental frequency, whereas higher partials cause the perception of a rattling sound that has lost its quality of pitch. In the case of low tones the tenth partial is still in the low fre-

quency range, hence the phenomenon described is particular for low tones (investigation of this point is being continued).

The pseudo-glottis is a caricaturally coarse imitation of the normal glottis. PELLEGRINI (1957) for this reason will not even hear of the word pseudo-glottis. In a discussion in which some facts are misrepresented, he comes to the conclusion that any constriction can produce a vibration of air suitable for the formation of voice, and that the larynx is essentially different from a constriction like the pseudo-glottis. We disagree. Both operate on the same principle. The normal vocal cords lie against one another along a rather great depth during phonation in the chest-register, as is clearly shown by frontal tomograms of the larynx. The subglottic pressure forces them apart. As soon as an air-bell has passed, they close again, beginning at the bottom. This closure is not only effected by the elasticity of the vocal cords, but in particular by the Bernoulli-effect, the decreased pressure on the medial side of the vocal cords when a rapid current of air passes through. Thus the air-current is, so to say, cut into slices by the glottis, the air penetrating through the glottis in separate puffs of air.

Fundamentally this is not different for the pseudoglottis. Only the distance the air-bells have to cover through the glottis is not a few millimeters, but a centimeter or more.

Just like the vibration of the normal glottis, that of the pseudo-glottis can be observed with the aid of a stroboscope. However, conditions must be favourable: a purely periodical vibration and a patient capable of retaining air in the oesophagus sufficiently long to permit the introduction of the mirror. We succeeded in the case of a few patients of seeing the vibrations accurately and in slow motion. We saw serpentine movements of the mucous membrane over a great depth (1-1½ cm.). The duration of the opening of the upper mucous-membrane folds was only short in proportion to the duration of the closed phase. This is quite in keeping with what one might expect from such a sharp sound as that of the oesophageal voice; we also find a relatively short opening phase in the chest-register, which is rich in overtones, of the normal voice.

Determination of the pitch is already difficult in those rare oesophageal voices that are purely periodical. It becomes quite

impossible if the vibrations of the pseudo-glottis are aperiodical, so that we can no longer speak of a tone. The occurrence of aperiodicity is attributable to various causes. In the first place to variations in the subglottic pressure. The volume of air in the oesophagus is only small; any folds in the mucous membrane below the level of the pseudo-glottis may easily influence the supply of air. In the second place the length and the elasticity are not so constant and adjustable as with the normal glottis. It is especially in this respect that it behaves as a coarse caricature of the larynx. The third and most important cause is the accumulation of mucus above the mouth of the oesophagus, a handicap troubling many patients (V.3). With these patients air-bells are forced in a highly irregular way through a varying thick layer of secretions. Owing to this it is rather a noise that is produced, than a tone. This does not detract much from the intelligibility at short range, but just like hoarseness of the normal voice it diminishes carrying-power and the voice is less pleasant to hear. Any sound containing enough energy in the range of the speech-formants may be molded into understandable speech. A practically white noise like the whisper is a good example in point. However, if a fundamental tone is present, which is accompanied by a great amount of high harmonics, enough sound-energy is bundled in the high-frequency range. As a result the voice carries farther.

The lower the fundamental tone, the closer the partials lie together. Owing to this vowels pronounced by a low male voice are sharper defined than those uttered by a high female or child's voice. The low fundamental tone of the oesophageal voice (provided it is purely periodical) together with the fact that it is rich in overtones is the reason that it is very suitable for an accurate pronunciation of vowels.

In this connection it is interesting to mention an experience volunteered by three patients on this point, viz. that relatives of theirs who are hard of hearing, understood their oesophageal speech better than their normal speech before the operation.

Some of the properties of the oesophageal voice discussed above, may be recognized in the sound-spectrum analyses.

Sonograms

The analyses were made with the Kay Electric Sound-spectro-

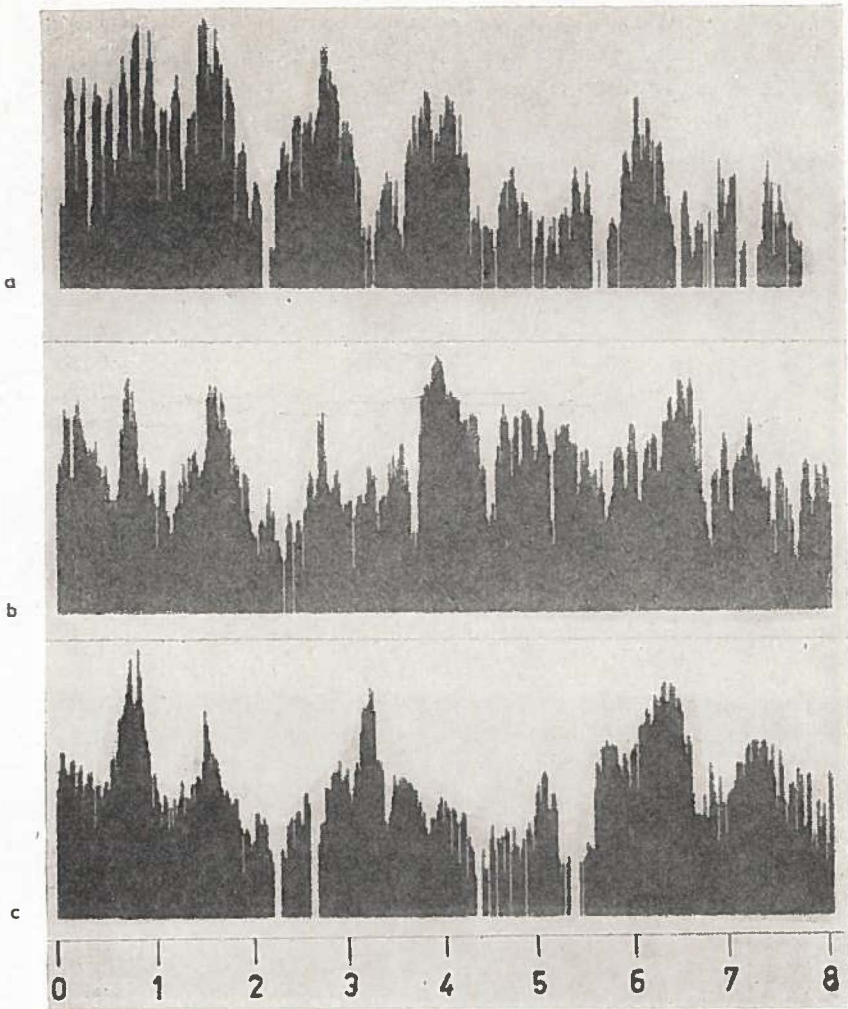

Fig. 11

Sections from sonograms (fig. 10). Frequency in kc.p.s. Vowel α :
 a. normal male voice b. and c. oesophageal speech: relatively more energy in the high frequency range.

graph, called Sona-graph. This apparatus permits the analysis of a sound-sample of a duration of maximum 2.4" in about five minutes. The sound sample is recorded on the magnetic rim of a rotating disk. Next it is reproduced in a continuous repetition. On each

repetition a following portion of the signal spectrum is scanned by a band-pass filter. The output of the filter is written on a prepared sheet of paper, which is stretched round a drum rotating along with the disk. The result is a registration in which the time is represented by the horizontal axis and the frequency by the vertical. The corresponding amplitude at a given frequency is represented by the degree of blackening. It is also possible to register the amplitude at a certain moment more accurately by having it written as length in the horizontal axis. This is called a *section*. The bandwidth of the filter may be narrow (45 c.p.s.) or wide (300 c.p.s.). The narrow filter is suitable for an acoustic analysis; the wide filter produces a better recognizable speech-pattern.

This method lends itself particularly well for the determination of the fundamental tone of the oesophageal voice, as TATO e.a. (1954) have also established. One may proceed in various ways. With the wide-band analysis each individual vibration of the glottis is seen as a vertical stripe. Owing to the very low frequency of the oesophageal voice these stripes are much wider apart than with a normal voice (fig 10). By counting the stripes over a certain range of time it is easy to calculate the fundamental frequency. The formants (i.e. the partials selected in the vocal tract) are visible as horizontal bands of intensive blackening. These can be seen more accurately in the narrow-band analysis. There the bands of the partials do not overlap and form individual black stripes. The distances between the stripes are a measure for their difference in frequency (the frequency is plotted linearly in vertical direction). From this, too, the fundamental frequency can be read. The same holds true for the sections. With moderate aperiodicity the irregularity of the air-puffs is well visible in the wideband analysis; in the narrow-band analysis blurring of the otherwise sharply written partials produces itself. What is seen in the sections, depends, of course, on whether the vibrations were periodical or aperiodical at the moment of analysis. So the sections cannot be used very well in judging of aperiodicity. With perfectly aperiodic voices no fundamental frequency is visible in the sonograms and no structure of harmonics is recognizable any longer in the higher frequencies.

Another method to evaluate the periodicity of a voice consists in running a tape-recording at a greatly (16 x) reduced speed. All

sorts of other details of the voice-period are also noticeable in this procedure, details that cannot be observed so directly in any other way.

Analyses of the sound-spectre have mostly been carried out with a view to comparing the vowel spectra with those of normal speech (SCHILLING, 1926; BECK, 1931; LUCHSINGER, 1951). It has been sufficiently demonstrated that there is little difference in the formants. This is understandable since the bucco-pharyngeal cavity has changed little. More important differences are to be expected in the formation of consonants. The consonants that are particularly affected are those requiring a large consumption of air (h, g), and those producing little acoustic effect in proportion to the air-consumption (m, n). The same cause, economy with the small quantity of available air, is often responsible for voiced phonemes being turned into their voiceless equivalents.

5. We will now discuss three patients with an unusual location of the pseudo-glottis (two in the pharynx and one still further in the front of the vocal tract). The drawbacks are mentioned and a way pointed out to change the pseudo-glottis to its proper place.

The patient no. 40 is a healthy and powerful man, born in 1916. He had been treated by X-ray for carcinoma of the left vocal cord in 1953. Six months afterwards recurrence of the growth was detected, the entire left cord was affected, with almost complete fixation of the cord. Total laryngectomy was performed in March 1954 by Prof. EELCO HUIZINGA. Speech therapy started two weeks afterwards with the usual exercises: short words beginning with plosive consonants. These, however, remained voiceless for a long time. It was also impossible for the patient to belch. Only after five days was the attempt for the syllable ta regularly accompanied by some sound; three repetitions could then be used as a start for any syllable beginning with a plosive (ta-ta-ta-kee, etc.). The light timbre, the high pitch and the small volume did indicate at that time that the voice did not originate from the oesophagus, but from the pharynx. The patient could produce neither an initial vowel nor an intentional belch. Later, an initial vowel could be made following an inconspicuous movement with the tongue. Long series of syllables with p, t and k could then be uttered. After two months the patient had his voice always at his disposal.

He was able, by slow and exaggerated distinct articulation, to keep up a conversation. The pharyngeal voice clearly had its drawbacks, the frequent short interruptions for the 'loading' of the syllables, caused by the small capacity of the air-chamber, resulting in slow and scanning speech. The voice lacked carrying force and was very dull as it could not be modulated by melodic, dynamic or temporal accentuation. At later visits the voice seemed to gain some strength, but the other characteristics remained unchanged. The patient still could not produce a ructus voluntarily.

For more than a year he carried on with this voice. The patient was then summoned for our investigation program.

Fluoroscopy revealed that the generator was located between a protrusion lying on the anterior pharyngeal wall and its posterior wall (Fig. 12a). Below the pseudo-glottis the hypopharynx was seen to pulsate with each voiced sound, thus serving as a small air-chamber. The bottom of this air-chamber was found at the level of the 6th cervical vertebra. This is the region where one would expect the ridge of the sphincter that forms the oesophageal mouth. No such ridge was visible, however; and the oesophagus did not contain any air. With the insufflation test, described in III. 4, the pressure exceeded largely the measurable limit of the manometer (100 cm of water) before the air could escape with a resounding ructus. This confirms the patients own experience during his post-operative speech training; he then had to drink two eight-ounce bottles of soda water before he succeeded in eructating. At any rate, an encouraging oesophageal sound was now heard, the air was not escaping through the cardia. An organic stenosis, resulting from the operation, which might form a barrier against the escape of air, was not likely since the man never had any swallowing complaints. Everything seemed to point to a functional spasm of the cricopharyngeal sphincter, or more exactly an inability to relax this sphincter voluntarily except during the act of swallowing. Therefore, treatment had to be directed towards abolishment of this reflex contraction.

A preliminary trial with drugs was not promising. There was no appreciable effect on the pressure level measured by the above mentioned method.

The patient was admitted for training in proper oesophageal speech in December 1955. Oesophagoscopy (by prof. EELCO HUI-

ZINGA) confirmed the radiographic findings; a small prominence on the anterior wall was seen; no obstruction was met lower down, the tube could be introduced with ease.

The following program, which we have outlined in IV.6, was established. Each morning the patient started by swallowing the thickest oesophageal dilatator (weighted with birdshot). Then the small catheter was introduced in the described manner and air was pumped into the oesophagus. At first he was instructed simply to allow the air to escape, without attempts at phonation. By looking at the manometer he had to try to reach the lowest possible pressure. The purpose of soundage and air injection was to make the patient conscious of dilatation and relaxation of the mouth of the oesophagus. After a few days the pressure was much lower (30–50 cm of water.)

During other sessions he was taught how to take in air by himself. The method of starting with plosive consonants was not applicable here, as this only forced the patient into his old spasmodic way of speaking. It was not possible for him to relax his sphincter sufficiently while making a positive pressure above it (IV. 6).

In the beginning he could draw a sufficient amount of air into the oesophagus only by swallowing with closed nostrils, as he himself had discovered. We encouraged this, as it might accustom him to the passage of air through the mouth of the oesophagus. At the same time we made him relax the muscles of the jaw and neck, which were very tense during any effort at speech. We hoped that the tension of the less consciously controlled muscles of the hypopharynx would diminish simultaneously.

In order to learn to dilate his pharynx maximally, he had to practice yawning regularly. This was not easily accomplished. A real yawn reflex could only be provoked by repeatedly going through the movements of deep inspiration with outstretched arms and wide open mouth together with the example of his teacher.

In this stage air entered easily into the oesophagus when he held his tracheostoma closed with a skinfold while yawning. This is easy to understand as the air pressure in the thorax, and consequently in the oesophagus, becomes highly negative during inspiration and highly positive during expiration with a closed tracheostoma. These pressure differences were just sufficient to make the air enter oeso-

phagus during inspiration and to press it out during expiration. In this way, with the tracheostoma held closed and after yawning, he succeeded in speaking his first words, without air being blown in by way of the catheter. This was soon possible without closing the tracheostoma; he still held his hand to his throat, but this served only to improve the sound by a slight external pressure upon the mouth of the oesophagus. After three weeks on the ward he was discharged. A pressure recording (III.2; fig. 3c) was made at this time; it shows a negative pressure in the oesophagus during the intake of air and no pressure changes in the pharynx. Fluoroscopy revealed that at the site of the former pseudo-glottis the pharynx was now wide open. The new pseudo-glottis was at the mouth of the oesophagus (fig. 12b).

For some weeks most of the words were spoken during the inspiratory phase, that is while air is being sucked in *). When this had been going on for some time the patient was ordered to stop this and to try to take air in without a sound. This was much to his disappointment, as the intake of air was attended by a nicer sound than was the air-expulsion. However he soon learned to suck air in noiselessly. By then he was able to use this voice satisfactorily for conversation.

A few months later a sudden improvement of his voice occurred, to the patients surprise and ours. He had been exercising with endless repetitions of 'pit, pat, peet' etc., and all of a sudden noticed that 'it went by itself', he 'could keep the air in'; he needed no more replenishment by suction. Evidently he had discovered the air-injection. This was later confirmed by new pressure recordings (shown in fig. 3d).

After the success with this patient we applied a similar therapy in the case of other patients who were in danger of developing a pseudo-glottis in a place other than the oesophageal mouth. By way of example we shall discuss patient no. 55 (already referred to III.3 and V.3 because of the peculiar shape of the pseudo-glottis, which was explained as the remainder of a wound-fistula). Soon after the first speech-exercises this man had acquired a more or less service-

*) This kind of 'two-way' speech has also been described by FROESCHELS, and by KALLEN (1932).

able pharyngeal sound. However, he did not succeed in producing the genuine oesophageal sound (the ructus). We then had recourse to air-injections by means of a rubber tube in the oesophagus, which had the desired result. After some days there was an occasional correct oesophageal sound after a many times repeated pa-pa-pa. However, too little headway was made. Next we decided to help this patient in the same way as the one described above (no. 40). In the morning before the beginning of the speech-exercises he was given to swallow an oesophageal dilatator (Charrière 40). Then the sound came off much more easily. After a few days of training practically all the exercises were pronounced without a pharynx-sound. The high pressure under which air was pressed into the oesophagus could be presumed from the high, compressed clucking sound that was heard to accompany the air through the oesophagus-mouth, and from the fact that sometimes during the injection of air the soft palate broke down with a snoring sound.

Pressure-registration took place a few months later when speech had become properly fluent, though air-injection was, between the words, still clearly audible. The table (fig. 5) registers an injection-pressure of 48 cm, which is very high indeed as compared with that of the otherspeakers. On inspection with the laryngoscope the picture of the oesophagus-mouth is different from that of the other patients. It cannot be recognized from the converging folds of the mucous membrane on the bottom of the hypopharynx, but it looks like a smooth annular stenosis. It is highly probable that there is a cicatricial stenosis here, for the patient has trouble in swallowing solid food, which he must always chew very well. At first the thickness of the dilatator was small only, and we did not get beyond Charrière 45.

A remarkable thing is that both these patients, who now rank among our most proficient speakers, still swallow their dilatator before breakfast. Many years after the therapy they still feel that this facilitates their speaking. If they stop using the dilatator for a spell, they clearly notice that speaking becomes more difficult. This is the reverse of GLUCK's experience: that after oesophagoscopy the voice temporarily vanishes. This may, however, be so with other oesophageal voices, when the patient temporarily loses control of the right degree of tension of the cricopharyngeal muscle.

The next patient has already been discussed in the section on the glossopharyngeal press (IV). He has not undergone laryngectomy, but suffers from an obstruction in the larynx. He will be dealt with here more exhaustively because he is a good example of special localizations of the pseudo-glottis. No fewer than three different speech-mechanisms were used in the course of his treatment.

The boy was born in 1941. When he was eighteen months old he fell victim to a diphtheria epidemic. Tracheotomy had to be applied. After the removal of the canula a larynx-obstruction appeared to have arisen. Operative treatment yielded no results, partly because the after-treatment was insufficient owing to war-conditions and partly because of lack of co-operation on the part of the parents.

In 1957, the boy being sixteen then, we faced the following situation. The larynx, which can hardly be recognized as such, has greatly lagged behind in growth; a very small epiglottis is the only landmark visible, vocal cords are not to be seen. The former operation has left behind a narrow fistula running from the roof of the tracheostoma to the base of the tongue, and joining the hypopharynx in the neighbourhood of the epiglottis. The air cannot escape from the trachea through this fistula; for breathing he is dependent on a canula. It is remarkable to find how the patient has seen his way to compensate for this obstruction of the air-passage. For instance, blowing his nose seems to be done quite normally. That this is not done by means of expired air can scarcely be believed by any one who is not conversant with the facts. He manages by pump-like movements of the tongue and the pharynx, so with the mechanism described in IV.2 and 3.

He speaks with a peculiar quacking sound. He manages all right in his own circle, he has acquired a complete mastery over the language, has been through the elementary school and a technical school. But his speech is practically unintelligible to strangers. His speech sounds monotonous. The differentiation between the vowels is bad and many consonants are missing. In certain series of speech-sounds, voice is completely missing.

The basic sound is formed by air being pressed from the throat cavity between the left palatine arches and the rim of the tongue. Hence the term glossopharyngeal speech is applicable here. The

tongue has thus a triple function: pseudo vocal cord, piston for the air and the normal function of moulding the pharyngeal and oral cavities for their properties of vocalic resonance; in fact, this last function gets the worst of it. It is something different from the parabuccal speech described by VAN GILSE (I.3). SCRIPTURE described a case that is presumably fully analogous to the present one. Only he mentions as a pseudo-glottis the constriction between tongue and palate.

We thought of ways and means to improve his speech. First of all it was oesophageal speech that came into consideration. However, all his life the boy had only used his frog-like speech, and could make himself intelligible with it at home so that he had no sufficient need to learn a different speech. In such a case it can be predicted that oesophageal speech-training will end in a failure.

We thought of using the fistula for the purpose of making a voice-prosthesis. We introduced a voice-whistle with a very small diameter into the fistula, but it did not function. It appeared, however, that a current of air blown into the fistula by means of a balloon produced a very fine voice-like sound. Evidently the mucous folds at the outlet near the base of the tongue were made to vibrate appropriately. It should be borne in mind that vocal cords are out of the question.

This discovery was exploited. An acrylic device was constructed*) that came up to the following requirements: to produce a fine tone at a minimum breath-pressure without air being capable of escaping through the canula. The device consists of a perforated stem having a length of 15 mm, fitting the fistula and mounted on a ring lying flush to the skin of the tracheostoma and rendering the escape of air outside the tube impossible. On expiration the ring is closed by a valve. Expiration without speaking is always possible by not pressing the prosthesis against the tracheostoma. (fig. 13).

While this device was being developed, Mrs. A. J. MOOLENAAR-BIJL trained the boy by means of insufflations with the aid of the balloon, in the articulation of normal speech, a thing he had never learned as a child.

The preparatory speech-therapy with the small balloon took about three months. The boy had to learn consciously the sound and

*) We gratefully acknowledge the cooperation of Dr. W. A. M. VAN DER KWAST and Mr. A. J. G. PIETERS, Dept. of Dental Surgery (Dir. Prof. M. HUT)

the relative articulation of all the vowels and nearly all the consonants, at first separately, then combined into syllables. The nasal consonants and the diphthongs [ei] and [æi] were the most difficult to learn, while the r is still impossible for him to pronounce. The composite consonants were mastered quickly. Because of the small air-capacity of the balloon speaking had always to be done syllable by syllable.

A great change for the better set in when the device could be put into operation. Now it is possible for the boy to speak more syllables in succession on a single breath. The speed is still slow, as yet there is not rhythm of long and short, light and heavy. The voice produced with the device sounds monotonous as well, but its carrying-power is greater, and its timbre much more approaches the normal voice than the frog's speech did. There is much more differentiation than in the frog's speech and owing to this much greater intelligibility. (fig. 14).

The device has one drawback in that must be pressed by hand in order to obtain a sufficient closure against the skin. This is why the boy has not come to use it regularly in practice. He has left school and is now employed in a ship-building yard as a bench-hand. The demands made upon him in his new surroundings plus the fact that he has got acquainted with the possibility of learning a new and better speech, are responsible for it that he shows an active interest in learning oesophageal speech. This is better possible now since he has learned normal articulation with the aid of the device.

He has now progressed to a point that two-syllable words are pronounced with ease. We must await whether he will reach a degree of proficiency that makes him drop the frogs' speech he has used all his life.

Historical note

A similar device has been described by BRIANI (1946). The principle was inspired by the artificial larynx denoted by GRAHAM BROWN in 1925. That a fistula such as this boy possessed, can produce a fine voice, was evidently known to the patient of GUTTMAN and BECK. This 56-year-old man, operated upon in 1935, was not satisfied with an artificial larynx or with oesophageal speech. We quote GUTTMAN: 'He studied his condition, and one day went to the trouble of heating an ice pick and passing it from the fistula in the trachea in the neck up through the hypopharynx toward the base of the tongue. As a result, a small fistula occurred, and he is now able to place his thumb over the tracheal opening in the neck and then force air from his lungs along this small fistula back into the mouth'. According to BECK it was the best voice he ever heard in a laryngectomized patient. The authors evolved an operation after this example, of which nothing more was heard.

SECTION VI. AIR-EXPULSION

1. By what force is the air in the oesophagus expelled through the pseudo-glottis? This question has not received the attention in the literature that it deserves. For it is a highly interesting problem how a laryngectomized patient can make a pressure up to 80 cm of water, while he is not able to shut off his respiratory tract from the outside air, like we do with our glottis. This has perhaps not been seen as a problem because it was not realized that such high pressures, as shown by our recordings, (III.2), occurred in the oesophagus of laryngectomized speakers.

Several attempts at explanation are not satisfactory:

a. Active contraction of the muscular wall of the oesophagus seems the easiest solution, is, however, the least likely. For the caudal $2/3$ consists for the greater part, and the caudal $1/3$ entirely of non-striated muscles and is therefore not subjected to voluntary contraction. Still, these muscles may play a part in raising the pressure in the oesophagus; but this is then a pressure-wave of peristaltic origin, which is even disturbing oesophageal speech by carrying away the air contents to the stomach.

The movement of the oesophagus during the expulsion of air, as seen on the X-ray screen, is termed an anti-peristaltic wave by some authors. But this is only apparently so (cf. also IV.1). If this was really the case, oesophageal speakers would be badly off, retching all the time.

b. Constriction by the diaphragm. This hypothesis is an obvious one, because the crura of the diaphragm are the only striated muscles encircling the oesophagus past the cricopharyngeal sphincter. However, in many speakers the air is seen to pass in and out of the upper half of the oesophagus only, and it is hard to understand how compression of the lower part only, could exert any influence on the pressure in the upper part, unless it be by stretching the oesophagus. But there is another objection: though we tried it with several patients, we have not known one who could speak during inspiration (this is when the diaphragm contracts). This would also be possible, if the oesophagus were actively contractible (see the explanation under a).

Combined action of the abdominal wall and the diaphragm (the abdominal press) is observed to come into play when a high pressure is needed for loud oesophageal speech. But we think that then the contraction of the diaphragm does not serve for building this pressure, but as a strong lock to prevent the air from entering the stomach. The weak cardiac sphincter would not be effective enough there.

2. In our opinion two mechanisms are at work. They can separately or jointly or successively build up the pressure expelling the air from the oesophagus against the tension of the cricopharyngeal sphincter.

a. The tonus and the elasticity of the oesophageal wall. We have seen that in good speakers the pressure in the pharynx during air-injection increases with the pressure in the oesophagus during phonation (III.2). If the sphincter of the oesophageal mouth is under good control, the pressure under which the air is pumped into the oesophagus, can be used instantaneously for speaking one or two syllables. This pressure is maintained for some time due to the elasticity and the muscle tonus of the oesophageal wall. However, only for a very short time, then the air is carried off by a peristaltic wave. Hence we see that injection and phonation are not two separate phases but constitute one whole. The air then left behind in the oesophagus is no longer under working-pressure. If this air is also used for speaking, another mechanism must start functioning.

b. Alveolar pressure in expiration. The laryngectomized cannot close off their air-passage in order to create a high intrathoracic pressure. But some events are also effective in this respect and may take the place of a closure. During a rapid expiration pressure is exerted on the walls of the bronchioli; in addition the great air-velocity results in a diminished pressure from the inside (Bernoulli phenomenon). The bronchi will be narrowed and the resistance, which is high anyway at this great velocity, is increased still more. Thus by rapid expiration a high alveolar pressure is build up.

In addition there is the phenomenon that the air-filled oesophagus presses against the dorsal wall of the trachea, where, owing to the absence of cartilagenous protection, it starts bulging during

the increase of the intrathoracic pressure. The trachea is narrowed, which causes the air-resistance to increase, etc. With some patients this link of the cycle is clearly visible when loud sounds are uttered.

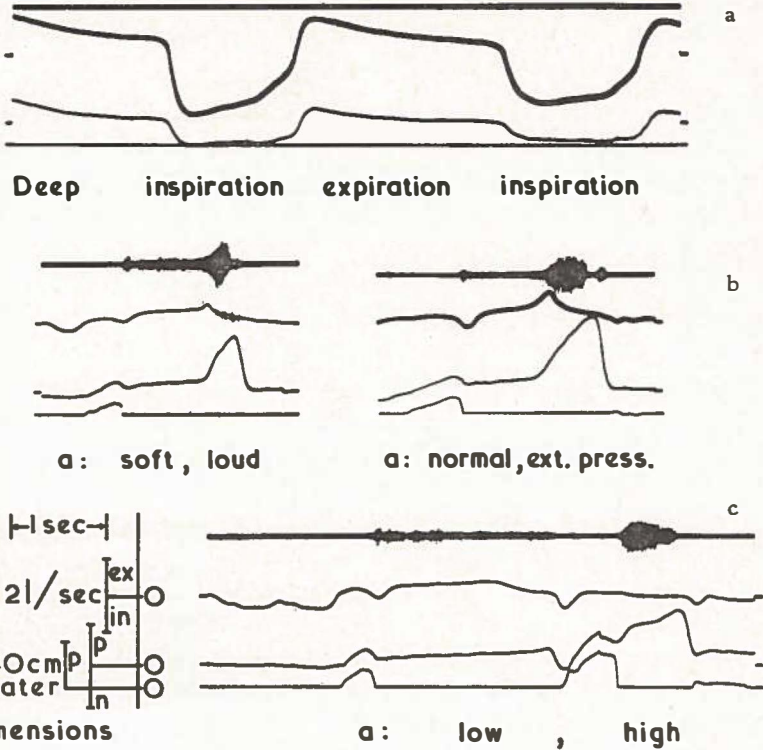

Fig. 15.

Simultaneous recording of the pressure in the pharynx (P), the pressure in the oesophagus (O), air flow to and from the trachea (F) and sound pressure (S).

- Inspiration is coupled with negative pressure in oesophagus, expiration with positive pressure.
- Loud sound is preceded by short expiratory flow and attended by a highly positive pressure in oesophagus. Finger pressure on the pseudo-glottis is attended by increase in oesophageal pressure and loudness.
- Attempt at high pitch is preceded by air injection under twice the pressure needed for low pitched sound.

This highly dynamic mechanism has as its consequence that, after an initial strong air-flow from the tracheostoma, the flow-rate decreases because of the great resistance in the bronchi. This mechanism chiefly becomes active:

1. if an extra-high pressure is required, such as for loud and high sounds, and with beginners who have a poorly controlled pseudoglottis and who generally let a long interval elapse between air-intake and phonation;

2. in the case of patients using the suction-method, because they cannot employ the mechanism described under a.

This explains why people who have a good control of the injection-method, have, in general, a less annoying canula-noise than beginners and people speaking with the suction-method, because the mechanism mentioned under A suffices in ordinary conversation.

These ideas were put to the test by the following experiments on some patients. By means of radioscopy the optimum position was determined in which both the upper part of the trachea and the oesophagus were visible at the same time. With the cine-camera a shot was taken of a softly spoken (a:) which was repeated a few times, followed by a shot of (a:) spoken very loudly. The difference was clearly visible: during the enunciation of a loud sound the lumen of the trachea is greatly reduced because the air-filled oesophagus dents the dorsal wall.

With some other patients the air-pressure recording was made in such a way that now the pharynx-catheter was introduced into the trachea. The result exceeded our expectations: in two out of three cases the air-pressure near the bifurcation (at 9 cm from the tracheostoma) reached during loud phonation the same height as the pressure measured simultaneously in the oesophagus. In the table (fig. 5) the pressure in the trachea is denoted by a hollow square (patients 37 and 26).

After this it is understandable that a touch of bronchitis, which would trouble a normal person but little, is already a very troublesome state to be in for the laryngectomized patient. Not only because coughing (through the open tracheostoma) is more difficult, but also because the rapid expiratory bursts during speaking provoke coughing. As a result his speech suffers badly.

3. The fact that speaking is connected with expiration was once more emphasized by ROBE e.a. (1956). This is in apparent contradiction to the great importance attached by numerous authors to the detachment of speech from expiration, which would be an important point in the beginning of speech-therapy.

Yet these authors are right in so far as the speech act does not begin with expiration, as in normal speech. First air must be taken into the oesophagus. As long as the patient does not master the technique of this, his attempts at speaking are attended with fruitless and superfluous expiratory movements. It is certainly correct to suppress these. In a later stage, when the intake of air is done automatically, the annoying canula-noise must be checked as much as possible. We have already seen that the injection-method has a great advantage in this respect over the suction-method because there is already a proper initial pressure at the onset of the voice. Yet here, too, phonation is attended with expiration. However, the latter is not audible, if the right technique is applied. The expiration is not directly connected with the sub-glottic pressure, for the mechanism described above comes in between. Therefore expiration and speaking are co-ordinated in a different way as compared to ordinary speech. But this does not mean that there is no relation at all between the two.

SECTION VII. REHABILITATION

1. No particular degree of intelligence is required on the part of the patient for learning oesophageal speech under expert guidance, provided that anatomical and functional conditions are favourable. This may be said with some emphasis since the preceding sections may have produced the opposite impression. There oesophageal speech was analyzed in a way that is important to the phonetician, but that does not concern the patient. Besides, the cases brought up were mostly of a pathological nature. Hence it is that the reader may have got the erroneous impression that learning oesophageal speech is a complicated thing for the patient. However, this is not so in the majority of cases. On the other hand, the intelligence of the patient may be a great help if there are difficulties of an anatomical or a functional nature. A patient endowed with a quick mind and capable of becoming aware of his kinaesthetical sensations, will the more easily be able to follow the directions of the therapist.

Patience should, of course, be available to a sufficient degree both on the part of the patient and on that of the therapist. However, the two of them should guard against an excess of this virtue. A proper measure of impatience may be helpful in not remaining at a dead-lock for too long a time, in assisting the therapist to strike out new paths in the treatment, and in stimulating the patient to keep looking for new ways of improving his speech. This is of particular importance when teaching oesophageal speech, since every patient presents us with a fresh complex of unknown factors which we have to find out empirically. A certain measure of mobility is necessary in order to reach the goal in the shortest possible time.

Mental depression may be the cause of failure. This subject was dealt with at length by NEUBERGER (1951). We have only come across a single case in which a depressed state, which was, for that matter, explicable and understandable, assumed pathological proportions; in the particular case senile dementia and deafness also played their parts. In the relative literature mention is made of some cases of suicide after laryngectomy (DE BRUÏNE-GROENEVELD, 1924; NEGUS, 1948). However, other authors do not share this

experience (ORTON, JACKSON, SCHALL). Since the morale of the patient is such an important factor in acquiring oesophageal speech, it ought to be promoted as much as possible. In the days of the clinical investigation preceding the operation, the patient is once, or several times, visited by a laryngectomee. If the latter has been rehabilitated with satisfactory results, he may help the patient to face with confidence the things that are to come. We are very fortunate in having among our former patients an emeritus clergyman who is in command of a very good speech and who is always willing to contact new patients. These visits are also very beneficent in helping the patient to get through the difficult post-operative period. There is no one who is better able to encourage a patient than a man who has gone through the same predicament.

When the wound has healed and speech-therapy can be started, the patient is, as a rule, so keen on this, that one is, at first, assured of his full co-operation. However, it is essential to keep the patient's attention and his will directed at his voice-exercises when he is momentarily discouraged owing to a temporary standstill. At such moments the value becomes evident of contact with fellow-patients and of common exercises. Then they realize that they are not alone in their misery, they help one another to keep their courage up, exchange useful directions, and carry on a healthy sort of competition in the field of speech-achievements.

From this it should not be inferred, however, that the teaching of oesophageal speech could be done best by a person who has undergone laryngectomy. It is possible that one may, by way of exception, find such a person to fit the part, but in general it is better to leave it to expertly trained persons. The peculiar task of a person who underwent laryngectomy, a task that cannot be performed so well by anybody, is to give moral support to other laryngectomy-patients thus aiding them to resign themselves to their fate and try to make the best of it.

With all operations involving the loss of some function or other, it makes all the difference whether this function was an important pillar of the personality or not. One is apt to think that the loss of speech would strike every one equally heavily. Yet there are great individual differences in this respect.

We shall take as an example a man, a chimney-demolisher. He told us he did not feel the lack of speech because he felt very little need of it. While at work he was alone all day, high above the ground, with his wife he exchanged an occasional word only, his children he seemed to control merely with his eyes. He paid little heed to unpleasant experiences resulting from his loss of speech. When he was on his way to us in Amsterdam, he had to ask a passer-by for the way. At the time he spoke very poorly as yet; the passer-by made a hurried exit and disappeared round the corner. To our patient this was a source of amusement, to another it would have meant a great hurt.

Though it is, for obvious reasons, rare that unwillingness hampers speech-rehabilitation, yet it occasionally occurs.

A mild case, rather one of aversion than of unwillingness, is that of a woman of 42. During the lessons given by a male speech-therapist, it regularly came to crying-fits. When she had given up the lessons, her peace of mind returned. Though possessed of an excellent oesophageal voice, she prefers, for aesthetic reasons, to make use of pseudo-whispered speech, with which she can make herself understand well.

Another instance is that of a man who cared little whether he could speak or not (see above). Outside the lessons given him, he did not practise at all. Notwithstanding, he got to speaking properly, be it much later than is normally the case.

An instance of a 'malignant' case is supplied by a patient who exploited his defect with a view to social insurance. This man had undergone laryngectomy, without complications. Everything was favourable and pointed to it that he would learn oesophageal speech without a hitch. But contrary to expectations there was no result after a few weeks. The patient confessed that he did not practise at home because he did not see the good of learning to speak again. It appeared he was afraid of having to go to work once he could speak again. He was then given a job which did not require him to speak and gave him practically nothing to do. Hoping that now there was nothing left to hamper speech-rehabilitation, a fresh start was made. But the treatment did not yield results, though nothing was left untried: exercises in all sorts of attitudes, aerated water, effervescent powder, and air-insufflation. These last manoeuvres resulted in the reproduction of uncontrolled sounds, but it did not come to the formation of speech-sounds. The unwillingness of this patient was finally quite evident when he refused further speech-therapy with the comment: 'My wife is hard of hearing and can understand me without sounds.' The man makes himself suitably understood with pseudo-whispered voice. His case must be looked upon as one of neurotic aphonia, even in the absence of a larynx.

2. If we ask ourselves to what degree these people are able to occupy their places in normal life, it may be said that the re-acquisition of speech has removed the most serious handicap. Yet there is still much that these persons are to miss.

Though oesophageal speech is suitable for conversation in the company of a few persons, it is inadequate as a means of communication in a larger company or in noisy surroundings. Nor can these persons laugh loudly any more, neither can they scold, weep, sing or whistle any more, while they are hardly able to express the

finer shades of their emotional lives in their speech. From an inquiry conducted by Mrs. MOOLENAAR-BIJL among the patients, it appears that it is particularly the lack of singing and ordinary chatting that is felt.

A striking example of an unexpected consequence of this lack of expression, was told by one of our female patients (no. 4). When she laughed, tears ran down her cheeks. However, the absence of the sound accompanying laughter, made people think she was crying, which produced a distressing situation.

The acoustic world is extremely important in communication among people. In spite of speech-rehabilitation a laryngectomy-patient runs the risk of getting lonely. A blind person receives, as a rule, very much attention and assistance from his fellow-men, and thus often experiences a proper amount of compensation for his defect. It is generally known that this is much less so with deaf people. Impaired hearing is therefore a heavy affliction, there being no compensation to counterbalance it. The laryngectomy-patient, too, can derive little compensation from his defect. Those close to him are prepared to take his difficulties into account, but how seldom do they succeed in this. Among strangers his speech often excites surprise, sometimes even revulsion.

The shortcomings of oesophageal speech do not only afflict man in his personal life, but just as well in his profession. Even if speech apparently plays only a minor part in it.

An office-manager who had always been very well capable of telling off his subordinates, now feels his oesophageal speech to be absolutely inadequate in this respect (oral communication by FRITZELL).

The following case of a baker shows how much the problems of oesophageal speech are interwoven with every-day life. This man had great difficulty in speaking after meals. For this reason he always ate small portions at a time only, for a customer might enter his shop at any moment for him to speak to. He emaciated visibly and was in a bad shape, until a good housekeeper brought relief in his business. She could answer the shop-bell as long as he was unable to speak after meals. After some time another problem presented itself, however. She cooked so expertly that the baker grew too fat, which impeded his speech to a degree.

The number of patients who have had to change their occupations is not large. Of the 40 patients of whom we possess data, eight were already retired when they were operated upon. Often patients retired a few years earlier than they would normally have done (seven cases). Among them were a teacher, a skipper, and an eel-

fisherman, for whom it would have been impossible to continue their occupations. The patients of the active age-groups could often carry on their usual work with slight variations, for instance, by being exempted from heavy bodily labour or from excessive speaking. Examples: a custom-officer at the frontier gets clerical work in the clearance-office; a baker only occupies himself with selling, so as to avoid flour-dust. Those few who changed their occupations were a waiter (who now works in an office), a violinist, and a cab-driver. Our favourable experiences are in keeping with those of R. HEYDEN (1950). Of his group of 36 patients only five were unable to provide for themselves.

3. In addition to speech, there are other impediments to rehabilitation. Generally speaking, dusty surroundings are undesirable. For the air used for breath no longer first passes through the nose and the throat, but enters the trachea directly. Investigations about the temperature of breathed air and about the changes of the mucous membrane in the respiratory tract allow of the conclusion that this impediment is not too bad. Most patients protect their tracheostoma with a cloth that is fixed under the shirt. Thus a dead space forms in which the air is pre-heated and filtered.

The following two examples prove that working in a dusty space is possible indeed. Patient (44) has continued his work as underground-miner. The management obliged him by making him a gang-boss, though his training for this job had not yet been completed. He wears a protection consisting of ten layers of gauze in front of his tracheostoma, the outer layers of which are replaced daily. Thus he is not troubled by dust, provided he stays away from the stone-galleries as much as possible. He has also fully kept up his hobby of motorcycling.

The chimney-demolisher discussed above, has not given up his job either because of the financial advantages. It is an occupation that is dangerous and that requires special experience. It is hardly possible to think of a more dust-raising job. A goodly six months after his operation he was already on the top of a 52-metre high chimney. The first time he was a bit dizzy, he said, but he soon got used to it again. To our question how he protected himself against dust, he answered that he always worked with his collar undone, without anything at all before his tracheostoma. 'It is heavy work, and I need plenty of air', he commented.

As to the function of the lungs HEYDEN (1950) as well as SCHWAB, EY and ULLMER (1958) did not find differences of importance from normal persons. Their conclusion is that validity is, as a rule, judged of too gravely.

It has been thought that lifting of weights required the capabi-

lity of closing the glottis. It was reasoned that the chest extended by its air contents would offer a firm attachment for the muscles of the trunk and the shoulder-girdle. LOEBELL and BRAHM (1950) demonstrated that this is unnecessary, at any rate for not too heavy weights (20 kg) so that, in this respect, wearers of a canula and laryngectomized persons are not at a disadvantage over against normal people.

A less palpable, but nevertheless weighty impediment is that these people live under the menace of a recurrent carcinoma. In the introduction we have mentioned that the prognosis is relatively favourable on comparison with malignity situated elsewhere. Yet this fear casts a shadow over the lives of many laryngectomy-patients. This factor affects their further existence in so far as they themselves and their employers take this danger into account.

4. A highly unfavourable situation exists if a pharyngostoma has arisen owing to a disturbance in the healing of the wound. This was the lot of some of our patients who had undergone one or more x-ray treatments before the larynx-extirpation. The patient with a pharyngostoma is in a poor state. Not only must the speech-rehabilitation which had been promised him, be abandoned, but he remains dependent on the stomach-tube for his food.

One of our patients found a way of getting rid of the latter inconvenience. He ties up the hole in the neck with a bicycle-tube, in which there are a half spoon and a leaden weight. Thus he can drink without liquid leaking from the pharyngostoma into the trachea. That is to say, as a rule all goes well. But once he was hospitalized for a short time with the symptoms of aspiration-pneumonia. Another patient copied and perfectionned this amazing equipment by means of foam-rubber and a plastic envelope. Following their example we equipped a third patient with an acrylic prosthesis shaped on a cast of the pharyngostoma. It is a small matter to make such a closure, but to the patient it makes all the difference seeing that he can again taste his food.

The defect is, with these patients, not closed by means of plastic surgery with a view to the dubious prognosis as to a recurrence, and because the skin on that spot has already shown it possesses poor healing-properties. If, in certain cases, one should nevertheless

want to proceed to a plastic closure, this method is to be recommended so as to bridge the intermediate period.

Two of these three patients produced with their artificial closure at once an oesophageal sound. We refrained from developing this into oesophageal speech, because this would bring in its train that the prosthesis was worn all day long. The skin could certainly not endure this.

We tried if we could help these people with an artificial larynx *). This, however, did not turn out to be a success, as might be anticipated. The intelligibility of speech depends largely on the transient sounds, phenomena of sound that particularly present themselves with explosive consonants and with the onset and arrest of vowels. Now, the latter is out of question with an artificial larynx which hums on uninterruptedly. In addition, the patient cannot possibly pronounce most of the plosive consonants. The pharynx-pressure required for this, cannot be raised because the pharynx is in open connection with the outside air via the defect. This leak in the glosso-pharyngeal press is at the same time the cause of it that these people cannot learn oesophageal speech, and that they cannot produce a pseudo-whispered speech. Hence it is that unfortunately all the possibilities (I.3) for substitute speech are unattainable to these persons, only because of the non-functioning of the glosso-pharyngeal press. So speech-rehabilitation is out of the question in the presence of a pharynx-fistula.

5. After laryngectomy without visible complications success depends on age, the correct technique, especially that of air-intake, the anatomical conditions at the mouth of the oesophagus, and the moral attitude of the patient towards his defect. Owing to all this the result may be highly diversified. Apart from those cases in which the imperfection of oesophageal speech bars the exercise of a profession and apart from heavy labour, most laryngectomy-patients might be declared fully valid. That this is often not done, is, in our opinion, justified. It is felt to be a just cause to offer these people, who have suffered a heavy loss in their personal lives, some compensation in the social sphere.

*) kindly placed at our disposal by Ortofon, Copenhagen.

SAMENVATTING

1. Inleiding

De strottenhoofdkanker heeft vergeleken met andere vormen van kwaadaardige gezweldgroei een relatief gunstige prognose. Het is noodzakelijk dat aan de revalidatie van patienten, bij wie wegens deze ziekte de larynx is geëxtirpeerd, veel aandacht wordt besteed.

De oesophagusspraak is van de verscheidene middelen, waarmee na larynxextirpatie een verstaanbare spraak kan worden nagestreefd, verreweg de beste. De voordelen, o.a. boven de z.g. kunstmatige larynx, worden besproken.

Patienten, die laryngectomie hebben ondergaan, ademen door een permanent tracheostoma (de opening, waar de luchtpijp in de huid van de hals is gehecht). De mond- en keelholte, waar de spraakklanken worden gevormd, is dus geheel gescheiden van de luchtweg. De slokdarmmond, waarvan de kringspier (musc. cricopharyngeus) bij de operatie zorgvuldig wordt gespaard, kan de lucht, die uit de oesophagus stroomt in trilling brengen (als bij een oprisping); het geluid, dat hierdoor ontstaat, is door oefening tot een zeer bruikbaar stemgeluid te maken.

De wijze waarop lucht in de slokdarm wordt ingenomen is een belangrijk onderdeel van de techniek van dit soort spraak. Mevr. A. J. MOOLENAAR-BIJL schreef in 1953 dat er verband bestaat tussen het uitspreken van explosieve medeklinkers (p, t, k) en het innemen van lucht. Dit had een van haar patienten met een zeer goede oesophagusspraak, bij zichzelf opgemerkt.

Met het in dit proefschrift vervatte onderzoek werd beoogd een nauwkeurig inzicht te krijgen in het mechanisme van de oesophagusspraak en de beste voorwaarden te leren kennen voor een goed resultaat van de spraakrevalidatie.

2. Historisch overzicht

De eerste gevallen van oesophagusspraak die zijn beschreven, betroffen patienten met een ondoorgankelijk strottenhoofd (dikwijls als gevolg van een poging tot zelfmoord). Patienten, bij wie laryngectomie was verricht, leerden soms spontaan weer spreken. Hoe-

wel allerlei soorten van kunstmatige larynxen werden toegepast, is steeds meer de slokdarmspraak als goede plaatsvervangende spraak erkend.

Uit de reeks van artikels, die over het onderwerp zijn verschenen, wordt een selectie naar voren gebracht. Daaruit blijkt, dat de oesophagusspraak eerst als een curieus verschijnsel werd gesignaleerd, vervolgens menigmaal uitvoerig fonetisch werd onderzocht en vooral in de laatste tien jaren werd gepropageerd als een vorm van revalidatie, die bij geen enkele laryngectomie-patient achterwege mag blijven.

Punten, waarover de meningen verdeeld zijn, krijgen in dit proefschrift de meeste aandacht;

de wijze, waarop de lucht wordt ingenomen

de gunstige voorwaarden voor een goed functionerende pseudoglottis

de wijze waarop de lucht uit de slokdarm wordt gedreven.

3. Experimenten

Bij 23 patienten, geopereerd door Prof. E. Huizinga tussen 1941 en 1956, werd een uitgebreid onderzoek gedaan. Buitendien zagen we nog vele patienten bij wie niet het volledige onderzoek werd verricht: in Groningen 20, in Amsterdam 24 en in Utrecht 8.

Het onderzoek omvatte de volgende experimenten:

a. gelijktijdige registratie van de druk in de slokdarm tijdens het spreken, de druk in de keelholte en het geluid. In een enkel geval werd daarbij nog de luchtstroom in en uit de trachea gaand quantitatief geregistreerd.

b. het meten van de druk waarbij de in de slokdarm gespoten lucht ontwijkt, als maat voor de spanning van de kringspier van de oesophagusmond.

c. het doorlichten in dwarse richting van de halsstreek met behulp van een beeldversterker om de plaats van de pseudoglottis, de vorm en wijze van functioneren bij iedere patient waar te nemen. Hierna werd een röntgenfoto gemaakt van de pseudoglottis tijdens het foneren, onder gebruikmaking van een contrastmiddel.

d. een röntgenfilm bestaande uit opnamen van de pseudoglottis, de streek van tong en pharynx en van de slokdarm.

e. korte opnamen van enkele andere patienten, ter nadere bestudering van verschijnselen bij het lucht innemen en -uitdrijven. Daarnaast werden de stemmen op de geluidsband vastgelegd en verschillende eigenschappen van de spraak gemeten: de snelheid, luidheid, toonhoogte. Het resultaat van alle metingen is neergelegd in fig. 5.

In de drukregistraties van bijna alle patienten is een karakteristiek patroon te herkennen: een drukverhoging in de pharynx, onmiddellijk gevolgd door een ongeveer even grote drukverhoging in de oesophagus; dan daalt de pharynxdruk plotseling tot nul en op dat moment zet de klinker in, terwijl de oesophagusdruk slechts weinig daalt en dikwijls tegen het einde van het geluid nog iets toeneemt.

In enkele uitzonderingsgevallen zien we dat de druk in de pharynx niet toeneemt, maar dat de oesophagusdruk even negatief wordt vóór de inzet van het geluid.

Deze bevindingen tonen aan, dat het merendeel der patienten de lucht onder druk in de slokdarm perst en dat slechts enkelen de lucht inzuigen.

4. Het innemen van de lucht.

De lucht wordt uit de mond-keelholte in de slokdarm geperst doordat het weke gehemelte de neusholte afsluit, terwijl de ruimte in de pharynx wordt verkleind, (o.a. door een achterwaartse beweging van de tong) en gelijktijdig de oesophagusmond wordt ontspannen.

Hetzelfde pomp- of persmechanisme (door ons „keel-pers” genoemd) komt b.v. in actie bij de Valsalva-manoeuvre en bij het krachtig articuleren van explosieve consonanten (fig. 6).

Bovendien wordt het door patienten met larynxobstructie of na laryngectomie gebruikt als mechanisme, dat de ontbrekende ademstroom kan vervangen bij ruiken, neus snuiten en pseudo-fluisterspraak. Ook is het identiek met de pompbeweging voor het glossopharyngeaal ademen.

De techniek van het lucht innemen lijkt op de eerste phase van de slikbeweging; het belangrijkste verschil is, dat bij het slikken de

oesophagusmond-reflectoir wordt geopend, terwijl een verhoging van de luchtdruk in de pharynx juist een sluitreflex opwekt. Deze reflex is fysiologisch adequaat, b.v. bij niezen en blazen, om te voorkomen dat er lucht in slokdarm en maag zal komen.

Bij het leren van de oesophagusspraak moet de patient de van nature reflectoir gesloten M. cricopharyngeus leren ontspannen. Meestal slaagt hij daar binnen enkele dagen reeds in. Volgens de methode van Mevr. A. J. Moolenaar-Bijl begint de patient dadelijk met het uitspreken van losse lettergrepen als pa, ta, ka, waarbij de stemloze explosief krachtig moet worden gearticuleerd. Het geluid, dat daarbij in het begin ontstaat wordt gevormd met behulp van lucht, die in de pharynx wordt samengeperst. Al spoedig dringt er ook lucht door de oesophagusmond naar binnen. Bij het ontwijken hiervan ontstaat de echte oesophagusstem. Deze wordt verder ontwikkeld.

Een enkele maal blijft de patient in het stadium van de pharynxstem steken. Met bijzondere maatregelen kan hij verder op de goede weg worden geholpen.

5. Pseudoglottis

In 37 van de 41 gevallen die met röntgendoorlichting en -foto's werden gecontroleerd, fungeerde de oesophagusmond als pseudoglottis. Andere plaatsen, die nog altijd als theoretische mogelijkheden in de literatuur worden vermeld, zijn van weinig practisch belang. Aan het eind van dit hoofdstuk worden twee gevallen beschreven, waarbij de pseudoglottis zich hoger in de pharynx bevond, en één enkel geval van „kickerspraak" of glosso-pharyngeale spraak (wegens de localisatie van de pseudoglottis). Deze patienten leerden alle drie met bijzondere middelen de oesophagusspraak.

Als men de vorm van de pseudoglottis op de röntgenfoto's (fig. 7 en 8) van goede sprekers vergelijkt met die van minder goede, dan vallen vooral de grilliger contouren bij de laatste groep op. Dikwijls is er in de voorwand van de hypopharynx, vlak boven de oesophagusmond, een uitstulping waarin zich gemakkelijk slijm ophoopt. De patienten bij wie dit het geval is, hebben alle een weinig fraai, borrelend stemgeluid. Met röntgenfoto's van één patient wordt

aangetoond dat zo'n uitstulping waarschijnlijk het gevolg is van een kleine dehiscentie van de pharynxnaad.

In principe wordt de stem door de pseudoglottis op dezelfde wijze gevormd als door de gewone stembanden. Stroboscopische waarneming van de trillende pseudoglottis leerde dat het quotient openingsfase/sluitingsfase bij de oesophagusstem zeer klein is.

De grondtoon van de oesophagusstem is op het gehoor zeer moeilijk te bepalen. Dit wordt verklaard doordat de grondtoon naar verhouding zwak is, terwijl er zeer veel hoge boventonen van grote sterkte zijn, waardoor een ratelend geluid ontstaat, dat zijn toonhoogte-karakter heeft verloren.

Uit geluids-spektrogrammen volgens het procédé van de Sonagraph kan de grondfrequentie worden afgelezen. Dikwijls echter zijn de geluidstrillingen zo on-periodiek, dat er in het geheel niet van een grondfrequentie kan worden gesproken.

6. Het uitdrijven van de lucht

Tijdens het spreken bereikt de druk onder de pseudoglottis waarden van gemiddeld 30 en maximaal 80 cm water. Bij het verklaren van dit feit staat men voor de moeilijkheid 1) dat de spierlaag van de slokdarmwand niet willekeurig kan worden gecontraheerd en 2) dat de laryngectomie-patient geen intrathoracale drukverhoging teweeg kan brengen door te persen met gesloten glottis.

De verklaring moet dan ook in andere mechanismen worden gevonden. Bij het spreken met de injectie-methode, bevindt de lucht in de oesophagus zich vlak voor fonatie onder een voldoende hoge aanvangsdruk om terstond door de elasticiteit van de wand weer te worden uitgedreven. Bij goede sprekers zijn injectie en fonatie geen twee gescheiden fasen, maar één geheel.

Wordt de lucht ingezogen of verloopt er een te lange tijd tussen de luchtinjectie en het foneren (dit is ook bij lucht slikken het geval), dan moet een ander mechanisme in actie komen.

Door een snelle uitademing worden de bronchi vernauwd, door toename van de druk van buiten en afname van de druk van

binnen (BERNOULLI-effect), en neemt de luchtweerstand toe. Daardoor loopt de alveolaire druk steeds meer op, terwijl de luchtstroom afneemt (fig. 15). Bij sommige patienten is de sterke vernauwing van de trachea als schakel in dit kringproces, duidelijk te zien. Zo is het zonder dat de luchtweg kan worden afgesloten toch mogelijk dat een hoge intrathoracale druk ontstaat. Wel treedt hierbij een hinderlijk canulegeruis op, hetgeen bij een juiste toepassing van de injectie-methode kan worden vermeden.

Uit het voorafgaande volgt de oplossing van een oude strijdvraag: of de oesophagusspraak gebonden is aan de uitademing, of dat hij daarvan geheel los staat. Het antwoord hierop is dus, dat uitademing en fonatie niet zo direct gekoppeld zijn als bij de normale spraak; beide zijn op meer ingewikkelde wijze gecoördineerd, maar staan zeker niet los van elkaar.

7. Revalidatie

Het moreel van de patient die laryngectomie heeft ondergaan, is van grote invloed op het uiteindelijke resultaat dat met de revalidatie wordt bereikt. Het contact met mede-patienten kan in dit opzicht zeer gunstig werken.

Er worden enige typische voorbeelden gegeven van moeilijkheden die deze patienten hebben in het dagelijks leven en in het beroep.

Evenals andere schrijvers hebben wij de ervaring dat slechts zelden een laryngectomiepatient zijn beroep niet meer kan uitoefenen.

LITERATURE *)

BOOKS

- Alves, Garcia: *Les troubles du langage*. (Masson, Paris 1951).
- Bose, H.: *Die Verengerung und Verschlussung des Kehlkopfes* (W. Keller, Giessen 1865).
- Briani, A. A.: *Metodo di plastica cutaneo-faringea per protesi fonetica in laryngectomizzati*. Tipografia commerciale (Venezia 1946).
- Caliceti: *Trattato di patologia e clinica O.R.L.* Vol. 2, 1738 (Capelli, Bologna 1948).
- Doehler, Mary.: *Esophageal Speech*. American Cancer Society, Boston (1953).
- Flatau: *Trastornos de la voz y de la palabra*; in *Tratado de O.R.L.* by Botey, p. 801 (Salvat., Barcelona 1925).
- Froeschels, E.: *Lehrbuch der Sprachheilkunde (Logopädie) für Ärzte, Pädagogen und Studierenden*. 3d ed. p. 373 (F. Deuticke, Leipzig u. Wien 1931); *Twentieth Century Speech and Voice Correction*. (Philosophical Library, Philadelphia, 1948).
- Gutzmann, H.: *Sprache ohne Kehlkopf*. (Kabitsch, Leipzig 1936).
- Hajek, M.: *Pathologie und Therapie der Erkrankungen des Kehlkopfes, der Luftröhre und der Bronchien*. (Kabitsch, Leipzig 1932).
- Jackson, C. J. and Jackson, C. L.: *The larynx and its diseases* (1937); *Diseases of the Nose, Throat and Ear*. (W. B. Saunders Co., Philadelphia 1946).
- Lederer, Francis L.: *Diseases of the Ear, Nose and Throat*. (F. A. Davis and Co., Philadelphia 1946).
- Lerche, William: *The Esophagus and Pharynx in Action*. (Charles C. Thomas, Springfield 1950).
- Lindsay, John K. (ed.): *1952 Yearbook of Eye, Ear, Nose and Throat*. (The Yearbook Publishers, Chicago, Inc., 1953).
- Luchsinger, R. and Arnold, G. E.: *Lehrbuch der Stimm- und Sprachheilkunde*. (Springer, Vienna 1949).
- Mackenty, John E.: *Cancer of the Larynx*. (New York 1927).
- Negus, Victor: *The Comparative Anatomy and Physiology of the Larynx*. (W. Heine-mann, London 1949).
- Nelson, Charles: *You can speak again, Post-laryngectomy speech*. (Funk and Wagnalls, New York 1949).
- Petersen, A.: *Über das postoperative Schicksal der Kehlkopfextirpierten*. Diss. Kiel, (1952).
- Pommez, J. M. E.: *Voix oesophagienne après laryngectomie totale*. Thèse Bordeaux (1952-1953).
- Stern, H.: *Der Mechanismus usw. bei Laryngektomierten*, *Handbuch Denker-Kahler V*: 494 (1929).
- Stetson, R. H.: *Motor Phonetics: A Study of Speech Movements in Action*. 2d ed. North Holland Publishing Co., Amsterdam 1951.
- Tarneau, J.: *Traité pratique de Phonologie et de Phoniatrie*. p. 802 (Maloine, Paris 1939); *Les maladies du larynx*. G. Canuyt (Masson, Paris); *Encyclopédie Medico-Chirurgicale O.R.L.* Paris (1951).
- Terracol, J.: *Les maladies de l'oesophage*. (Masson, Paris 1951).
- Zapf, R.: *Ueber die Bildung der Sprache und Stimme nach Laryngektomie*. Diss. Hamburg (1923).

*) We thank Miss Evelyn Robe (Univ. of Chicago) for her valuable contribution in providing a list of the American literature.

ARTICLES

- Allen: Faculté de parler sans larynx. *Medical News* 17 March 1894.
- Anderson, J. O.: Bibliography on esophageal Speech. *J. Speech and Hear. Disorders* **19**: 70-72 (1954).
- Ardissone: Causas de dificultad en la reeducacion de un laringectomizado. *Boletin Soc. Argentina de Logop. y Foniatria* **6** (1951).
- Baccarani, C.: Respiratory tract of laryngectomized individuals; Clinical and symptomatic study. *Oto-rino-laringologica Italiana*, **12**: 376-341 (1942).
- Badcock, M.: Speech therapy for certain vocal disorders. *Journ. Laryngol. Otol.* **57**: 101 (1942).
- Bandler, A.: Ueber die Sprachbildung bei Luftdichtem Kehlkopfverschluss. *Zeitschr. f. Heilk.* **9**: 423 (1888).
- Bangs, Jack L.: Bibliography; Esophageal speech, *Journal of Speech Disorders*, **12**: 339-341 (1947); with Lierle, D., and Strothers, C.: Speech after laryngectomy, *Journal of Speech Disorders*, **2** 171-176 (1946).
- Bardier, J.: La voix sans larynx. *Annales d'Oto-Laryngologie*, **60**: 131 (1943).
- Bartalena, G.: Alcuni Riflessi Olfatto Secretori Considerati come Espressioni delle Capacita Olfattori del Laringectomizzato. *Oto-rino-laringologica Italiana* **20**: 256 (1952).
- Bateman, G. H.; Dornhorst, A. C.; Leathart G. L.: Oesophageal speech after laryngectomy. *Br. Med. Journ.* p. 1177 (1952).
- Bayer, H. G. A.: Nachuntersuchungen bei Laryngektomierten. *Hals- usw. Arzt* **28**: 329 (1937). (Ref. in *Ann. d'Otol.* 1940 p. 106).
- Beatty, Hugh C.: Cancer of the larynx and nasal accessory sinuses, *Ohio State Medical Journal*, **43**: 843-846 (1937).
- Beck, J.: Zur Phonetik der Stimme u. Sprache Laryngektomierter. *Z. f. Laryngol., Rhin., Otol.* **21**: 506 (1931); Living laryngectomized patients, *Archives of Oto-laryngology* **29**: 590 (1939); Phonetische Untersuchungen an Laryngektomierten. *Archiv. f. Hals-, Nasen und Ohrenheilkunde*, **165**: 576 (1954); La voix oesophagienne de remplacement des laryngectomisés. *Rev. de laryng., otol., rhinol.* **77**: 729 (1956).
- Bellussi, G.: Il problema della reintegrazione vocale negli esiti degli interventi sulla larynge e sulla farynge. *Atti Clinica O.R.L.* **8**: 177 (Torino 1949); Contributo alla conoscenza del problemi fonitici negli esiti degli interventi per cancro laryngeo. *Minerva O.R.L.* p. 501 (1952).
- Berg, JW. van den, Moolenaar-Bijl, A. J., Damsté, P. H.: Oesophageal speech. *Folia Phoniatic.* **10**: 65-84 (1958).
- Badcock, M.: Speech therapy for certain vocal disorders. *Journ. L.O.* **57**: 101 (1942).
- Berger, W.: Ueber subglottische Druckmessungen bei Kanülenträgern. *Z. Laryngol. usw.* **25**: 28 (1934); Beiträge zur Analyse pathologischer Stimmklänge, *Ber. V. Versamml. dtsh. Ges. f. Spr. u. Stimmhkl.* Berlin 1936.
- Bering Liisberg, H.: Om strubekraefte og dens behandling. *Tale og Stemme* **7**: 1-13 (1943).
- Botey, R.: De la fonacion despues de la extirpacion total de la laringe. *Archivos de Rin. Larin. Otol.* **25**: 25 (1914); De la voix pharyngée. *Ann. des mal. de l'Oreille, du Larynx et du Nez.* **7**: 675 (1914).
- Bourguet: *Gazette Médicale de Paris.* p. 137 (1856).
- Brankel, O.: Patho-physiologie der Pseudosprache Laryngektomierter. *Archiv. f. Ohr.-Nas.-Kehlk. Heilkde.* **149**: 491-496 (1941), and **165**: 570 (1954); Formung und Gestalt der Pseudoglottis Laryngektomierter in Stroboskopischen Röntgenbild. *Folia Phoniatic.* **9**: 18 (1957).

- Braun: Totale Kehlkopfextirpation. Sprache mit und ohne Künstlichen Kehlkopf. *Deutsche Med. Wochenschr.* **5**: 118 (1901).
- Briani, A. A.: Symposion de Foniatria. Padua (1951). Riabilazione fonetica di laringectomiazati. *Arch. Ital. Otol.* **63**: 469-475 (1952).
- Brighton, G. R., and Boone, W. H.: Roentgenographic demonstration of method of speech in cases of complete laryngectomy. *Am. J. Roentgenol.* **37**: 571-583 (1937).
- Brown, R. Graham: A simple but effective artificial larynx. *Journ. of Otol. and Laryngol.* p. 739 (1925).
- De Bruïne Groeneveldt: De spraak na extirpatie van het strottenhoofd. *Ned. Tijdschr. v. Geneesk.* **68/2**: 1448-1449 (1924).
- Brunetti, F.: Nachforschungen über die Tätigkeit des Schlundes bei Patienten u.s.w. *Arch., f. Ohr.-Nas.-Kehlk. Heilkde.* **149**: 491-496 (1941).
- Cabana, R.: La rehabilitacion oral del laringectomizado. *Rev. Cubana O.R.L.* **3**: 139 (1954).
- Bruno, Paludetti, Paroni: Rilieri radiografici sulla localizzazione della pseudoglottide nella emissione della voce alaringea. *La Clinica Otorinolaringoiatria* **5** (1953).
- Burger, H.: Speech without a larynx. *Journal of Otology and Laryngology*, **40**: 789-792 (1925) with Kaiser, L.: Speech without a larynx, *Acta Oto-laryngologica*, **8**: 90-116 (1925).
- Calderin, A. M.: Scientific principles in surgery of laryngeal cancer. *Anales de la Real Academia Nacional de Medicina*, **67**: (1950).
- Mc. Call, J. W.: Preoperative training for the development of the esophageal voice in laryngectomized patients. *Annals of Otol. Rhin. Laryngol.* **52**: 364-376 (1943); Preliminary voice training for laryngectomy. *Transactions of American Laryngol-Rhinol. Otol. Soc.* **47**: 45-56 (1943); and *Arch. of Otolaryngol.* **38**: 10-16 (1943) with Dixon, L., Hoerr, N.: The mucous membranes after laryngectomy. *Ann. of Otol.* **58**: 535 (1949), *Arch. of Otolaryngol.* **51**: 454 (1951) with Fisher, R.: Carcinoma of the larynx, A report of 194 cases with 149 laryngectomies, **62**: 475 (1952) with Stover: Review of 45 cases of laryngectomy for laryngeal cancer *Laryngoscope* **54**: 659 (1944)
- Mc. Caskey, C. H.: Voice apparatus in laryngectomized patients. *Transact. Ind. Acad. Ophthalmol. and Otolaryngol.* **23**: 44-47 (1940).
- Chapin, Amy B.: New voices after laryngectomy. *Ohio Speech and Hearing Therapist*, **2**: 1-2 (1949).
- Chiloff, C. L.: Contribution à l'étude du développement du langage chez les laryngectomisés. *Rev. de Laryngol.* p. 581 (1925).
- Cleminson, F. T.: Method of increasing audibility of speech after laryngectomy. *Proceedings of Royal Society of Medicine*, **22** Section 24 (1928-1929).
- Clerf, L. H., and Putney, F. G.: Cricopharyngeal spasm. *Laryngoscope*, **52**: 944-953 (1942).
- Cleves, C.: Rehabilitacion de la voz despues de la laryngectomia total. *Revista Facultad Medicina Bogota* **18**: 405 (1949).
- Cojazzi, L.: Sulla funzione esofagea esonetica vicariante nei laringectomizzati. *Atti del Laborat. d.Fonetica dell'Univ. Padova*, **1**: 41 (1949).
- Cova, P., and Antoniazzi, B.: Resultats statistiques de 313 cas de cancers du larynx traites par la roentgen-therapy. de 1928 à 1946 à l'Institut National du Cancer de Milan, *Radiologica Clinica*, **21**: 4 (1952).
- Cramer, I. I.: Heat and moisture exchange of respiratory mucous membrane. *Ann. Otol, Rhinol., Laryngol.* **66**: 327 (1957).
- Crowe, S. J., and Broyles, E. H.: Carcinoma of the larynx and total laryngectomy. *Annals of Otol. Rhinol. and Laryngol.* **47**: 875 (1938).
- Cunning, D. S.: Diagnosis and treatment of laryngeal tumors. *Journal of American Medical Association*, **142**: 73 (1950).

- Cutler, Max.: Radiotherapy of early cancer of the larynx, 5 year results in 156 cases. *Journal of American Medical Association*, **142**: 957-963 (1950).
- Czermak, J.: Ueber die Sprache bei luftdichter Verschlussung des Kehlkopfs. *Sitzungsberichte Akad. d. Wissenschaften*. **35**: 65 (Wien, 1859).
- Dahm, M.: Schluckstörungen und Schlucklähmungen. *Fortschr. Röntgenstr.* **64**: 167 (1941).
- Dahmann, H.: Ueber die Lumen- u. Druckverhältnisse in der Speiseröhre, *Z. Hals- usw. Hlk.* **7**: 329-377 (1924).
- Daly, J. F.: Treatment of carcinoma of the extrinsic larynx and laryngopharynx. *New York State Medical Journal*, **52**: 23 (1952).
- Damsté, P. H., van den Berg, J. W., Moolenaar-Bijl, A. J.: Why are some patients unable to learn esophageal speech? *Annals of Ot. Rhin. and Lar.* **65**: 998-1006 (1956).
- Decroix, G., and Depoorter, R.: La voix sans larynx. *Lille Chirurgical*, **7**: 82 (1952).
- Dénes, László.: Changed method of voice and speech after laryngectomy. *Orv. Hét.* **82**: 1237-1238 (1938); *Abstr. in Zentralbl.* **32**: 201 (1939).
- Dornhorst, A. C., Negus, V. E.: Speech after removal of upper end of oesophagus and the larynx. *Brit. Med. J.* **4878**: 16-17 (1954), with Leathart, G. L.: *Lancet* **2**: 109 (1952).
- Dub, A.: Algunas consideraciones sobre el lenguaje del laringectomizado. *II Congreso Sud-Americano de O.R.L.* p. 333 (1944); *Soziale Einrichtungen zur Hilfe für die Kehlkopfoperierten in Uruguay. Arch. f. Ohr.-Nas.- Kehl.* **165**: 568 (1954); *Un método para conseguir la voz esofágica del laringectomizado. Anales Fonol. Audiol.* **2**: 6 (1956).
- Dupuy, H.: Voice without larynx. *New Orleans State Medical Journal*, **82**: 791-792 (1930).
- Equen, M.: The rehabilitation of the laryngectomee. *Arch. Otolaryngol.* **64**: 1-2 (1956).
- Erbslöh, H.: Kehlkopfverletzungen. *Arch. Sprach u. Stimmheilk.* (1937).
- Fabricant, N. D.: Esophageal speech. *Eye, Ear, Nose, Thr. Mon.* **32**: 98-104 (1953).
- Falbe-Hansen, J.: Om strubekraefte og dens behandling. *Tale og Stemme*, **7**: 57 (1943).
- Falk, P.: Erfahrungen mit der Garcia-Hormaeck-Naht nach Totalexst. des Kehlkopfes. *Zeitschr. f. Laryngol. Rhinolog. u. Otol.* **35**: 158 (1956).
- Farina: La voz vicariante en los laryngectomizados. *Rev. Esp. Amer. de Laryngol. Otol. Rinolog.* 1949, p. 33.
- Faulkner, W. B.: Objective esophageal changes due to psychic factors; an esophagoscopic study with report of 13 cases. *American Journal of Medical Science*, **200**: 796-803 (1940).
- Ferrari, R. C.: Sobre el mecanismo de la fonación esofagica después de la laringectomía. *Boletín del Instit. de Clin. Quirurg.* **23/181**: 104 (Buenos Aires, 1947); *Modificaciones radiológicas del esofago consecutivos a la fonación esofagica. Boletines y Trabajos de la Academia Argentina de Quirurgica*, **35**: 15 (1951).
- Flatau, Th.: Die Störungen der Stimme nach Lebensstufen und die Stimme der Kehlkopflosen. *Festschr. Kubo* p. 41 (1934).
- Fornasari, G.: Considerations and research on olfactory functions in laryngectomy. *Bolletino delle Malattie dell' Orecchio, della Gola, del Naso, di Tracheo-Bronco-Esofagoscopia e di Fonetica*, **69**: 27 (1951).
- Forns: Presentacion de cilindros fonograficos impresionados por la voz de un laringectomizado. *II Congreso Español O.R.L., Barcelona 1899*; p. 164
- Fraenkel, B.: Über den Kunstlichen Kehlkopf und die Pseudostimme. *Berlin. Klin. Wochenschr.* **31**: 756 (1893).

- Freud, Esti D.: Speech therapy: experiences with patients who had undergone total laryngectomy. *Arch. of Otolaryngol.* **48**: 150-155 (1948).
- Froeschels, E.: Sprechen ohne Kehlkopf. *Wien. Med. Wochenschr.* **64**: 150 (1914); Über Oesophagusatmung eines Larynektomierten. *Wien. Med. Wochenschr.* **76**: 875 (1926); Ein Fall von Oesophagusatmung u. Oesophagusstimme nach Kehlkopfexstirpation. *Journ. of Laryngology* (1949) *W. med. Wschr.* **78**: 1435 (1928); Therapy of the alaryngeal voice following laryngectomy. *Archives of Otolaryngol.* **53**: 77 (1951).
- Fumagalli, G., Ottoboni, A.: Valutazione dei volumini polmonari 'statici' e 'dinamici' in soggetti portatori di neoplasia laringea. *Minerva Otorinolaringol.* **8**: 57 (1958); Valutazione dei volumini polmonari 'statici' e 'dinamici' in soggetti laringectomizzati. *Ibid.* **8**: 61 (1958).
- Garcia-Tapia, Y, Hernando.: New procedure for the treatment of cancer of the larynx. *Anales de la Real Academia Nacional de Medicina*, **67**: 3 (1950).
- Garde, E. Physiologie et pathologie de la voix oesophagienne. *Rev. de laryng., otol., rhinol. Suppl.* Février p. 149 (1953).
- Gardner, Warren.: Rehabilitation after laryngectomy. *Public Health Nursing*, **43**: 612-615 (1951); *Cleveland Clinic Quart.* **22**: 70-75 (1955).
- Gatewood, E. T.: The development of esophageal speech after laryngectomy. *Southern Medical Journal*, **36**: 453-455 (1943); Mechanism of esophageal voice following laryngectomy, *Virginia Medical Monthly*, **71**: 9-13 (1944); A simple and practical procedure for developing esophageal voice in the laryngectomized. *Annals of Otol. Rhinol. and Laryngol.* **54**: 322 (1954); A new and simple procedure for developing esophageal voice in the laryngectomized patient. *Virginia Medical Monthly*, **73**: 206-209 (1946).
- Gemelli: La voce dei Laryngectomizzati rieducata. *Symposium de Foniatria de Padua* (1951).
- Gilse, P. H. G. v.: Über den Mechanismus des Ructus uws. *Arch. Néerl. Phon. Exp.* **5**: 37 (1930); Over perichondritis laryngea en de spraak zonder doorgankelijk strottenhoofd. *Ned. Tijdschr. v. Geneesk.* **77**: 2402 (1933); Another method of speech without larynx. *Acta Otol. Suppl.* **78**: 109 (1949); Verschillende methoden van vervanging van de menselijke spraak. *Ned. Tijdschr. Geneesk.* **100**: 453-458 (1956).
- Gleitsmann: De la voix pharyngée. *Arch. Internat. de Laryngologie* No. 4 (1909).
- Gluck, Th.: M. Ohrenheilk, p. 162 (1904); *Z. G. Laryngol.* **1**: 190 (1909); Künstlicher Stimmersatz nach Larynx-Chirurgie. *M. Ohrenheilk.* **64**: 881 (1930); Patienten mit Totalexstirpation des Pharynx, Larynx und Oesophagus, denen eine Künstliche Stimme durch eine automatisch arbeitenden Apparat geliefert wird, *Berl. Klin. Wochenschr.* 1910.
- Göbell: Stimmbildung nach Kehlkopfextirpation. *Deutsche Med. Wochenschr.* **50**: 1234 (1924).
- Gottstein: Pseudostimme nach Totalexstirpation des Larynx. *Archiv. f. Klin. Chir.* **62**: 126 (1900).
- Greene, J. S.: Rehabilitating the laryngectomized patient. *Bulletin of the American Society for the control of cancer.* **24**: 3-4 (1942); Composite postoperative therapy for the laryngectomized. *Laryngoscope*, **53**: 13-16 (1943); Postlaryngectomy Clinic of the National Hospital for Speech Disorders: Statistical Study of 300 patients. *New York State Journal of Medicine*, **49**: 2398-2404 (1949).
- Guns, P.: Production of voice after laryngectomy. *Scalpel*, **86**: 549-552 (1933); La voix après laryngectomie. *Rev. fr. Phoniatr.* **1**: 79 (1933); Laryngectomie reconstructive. *Rev. L.O.R.* **2**: 509 (1953).

- Gussenbauer, C.: Über die Erste durch Th. Billroth am Menschen ausgeführte Kehlkopf Exstirpation und die Anwendung eines Künstlichen Kehlkopfes. *Archiv. f. Klin. Chir.* **17**: 343-356 (1874).
- Guttman, M. R.: Tracheopharyngeal fistulization; a new procedure for speech production in the laryngectomized patient. *Transactions of American Laryngological, Rhinological and Otolaryngological Society*, **41**: 219-226 (1935); Rehabilitation of the voice in laryngectomized patients. *Arch. Otolaryng.* **15**: 478 (1932).
- Gutzmann, H.: Stimme und Sprache ohne Kehlkopf. *Verh. d. I Internat. Laryngol. Rhinol. Kongr.* (1908) *Zeitschr. f. Lar. Rhin. Otol.* **1**: 221 (1909); Über die Oesophagusstimme. *D. Med. Wochenschr.* **13**: 520 (1925); Sprache ohne Kehlkopf. *D. Med. Wochenschr.* **60**: 319 (1934); Kann ein Patient ohne Kehlkopf wieder Sprechen? *Z. ärztl. Fortbildg.* **30**: 79 (1933).
- Guyot, C. et Guyot, R. T.: Catalogue d'étude de ce qui a été publié jusqu'à nos jours sur les sourds-muets, sur l'oreille, l'ouïe, la voix, le langage, la mimique, les aveugles etc. Groningen 1842.
- Hanson, H. V.: Carcinoma of the larynx, laryngectomy, artificial larynx. *Med. Bull. U.S. Vet. Admin.* **13**: 61-63 (1936).
- Hanson, W. L.: A new artificial larynx with a historical review. *Ill. Med. J.* **78**: 483-486 (1940).
- Haries, J. R. and Lawes, W. E.: The advantages of glossopharyngeal breathing. *Brit. Med. Journ.* (1957) p. 1204 and 1205.
- Hartenau, W.: Die Sprechfunktion Laryngektomierter. *Archiv f. Ohr-, Nase-, Kehlk. Heilk.* **156**: 461 (1950).
- Heindl, A.: *M Schr. Ohrenheilk.* **66**: 931 (1932).
- Hendrick, Jennie: Voice without a larynx. *Formal Papers of American Society for Study of Speech*, p. 22-26 (1932).
- Heyden, R.: The respiratory function in lar. patients. *Acta Oto-lar. Suppl.* **75** (1949); **85** (1950) Stockholm.
- Hodson, C. J. and Oswald, M. V. D.: Speech recovery after total laryngectomy. (E. and S. Livingstone Ltd, 1958).
- Hofmann-Saguez, R.: La laryngectomie reconstitutive technique personnelle. *Rev. de laryng. otol. rhinol.* p. 143. (1953) (disc. *ibid.* p. 398) with Djian, A.: A propos d'une reconstitution fonctionnelle de la voix après laryngectomie totale. *Ibidem* p. 505 (1953).
- Hoople and Brewer: Voice production in the laryngectomized patient. *Annals of Otol. Rhinol. Laryngol.* **63**: 640-650 (1954).
- Hopmann: Stimm- und Sprachübungen nach Kehlkopfausrötung. *Deutsche Zeitschr. f. Chir.* **99**: 301 (1909).
- Hoshino, T.: Complete extirpation of the larynx in carcinoma. *Annals of Otol. Rhinol. Laryngol.* **28**: 466-472 (1919)
- Howie, T. O.: Esophageal speech sounds as a means of intercommunication, *Surgo*, **12**: 14-19 (1945); Rehabilitation after total laryngectomy. *Glasgow Med. J.* **27**: 45-48 (1946); Rehabilitation of patients after laryngectomy. *Occupational Therapy and Rehabilitation* **26**: 372-383 (1947).
- Huet, P. C. et Nemours-Auguste: Etude radio-physiologique du premier temps de la déglutition, isolé. *Arch. des Maladies de l'app. digest.* **32**: 113 and 167 (1943).
- Huizinga, E.: Recherches sur un ventriloque néerlandais. *Arch. néerl. Phonét exp.* **6** (1931); with Moolenaar-Bijl, A. J.: Over de belangrijkheid van het aanzetstuk. *Log. en Phon.* **12**: 7-8 (1940); Kompensierung im Ansatzstück bei der Bildung von Selbstlauten. *Arch. Néerl. Phon. exp.* **17**: (1941).

- Hyman, M.: An experimental study of artificial larynx and oesophageal speech. *Journ. Speech and Hearing disorders.* **20**: 291 (1955).
- Iglauer, S.: Artificial larynx, with patient demonstrating its use. *Ann. of Otol.* **45**: 1176 (1936).
- Iwanow, Alexander: Über die Stimme Laryngektomierter. *Z. f. Laryngol* (1910).
- Jackson, C. L.: The voice after direct laryngoscopic operations, laryngofissure, and laryngectomy, *Archives of Otolaryngology* **31**: 23-26 (1940); *Surg. Gyn. Obst.* **70**: 537 (1940); Cancer of the larynx, *Postgraduate Medicine* **6**: 379 (1949) with Jackson, C.: Increasing incidence of cancer of the larynx. *Transactions of American Academy of Ophthalmology* **45**: 156-175 (1941).
- Jesberg, N.: Speech after laryngectomy, *Med. Times, Great Neck* **84**: 1312-1314 (1956)
- Jimenez: La phonation chez un laryngectomisé. *Comptes Rendus de l'académ. méd. Chirurg. espagnole.* 14 April 1921.
- Johnson, C. A., Holinger, P. and Andrews, A.: Electrocardiogram changes after laryngectomy. *Arch. of Otolaryng.* **47**: 835 (1948).
- Jourdan et Collet: L'influence du pneumogastrique sur l'oesophage et l'estomac. *Ass. des Phys. de Langue Franç. Journal de Physiol.* **41** No. 2 (1949).
- Juan, P. de: Voz alaringea. *Acta Otorinolar. Iber-Amer.* **8**: 411 (1957).
- Kaiser, L.: Examen phonétique d'un sujet privé de larynx. *Arch. néerl. Physiol.* **10**: 468 (1926) with Burger, H.: Spraak zonder strottenhoofd. *Ned. Tijdschr. v. Geneesk.* **68/2**: 906 (1925).
- Kallen, L. A.: Discussion of Mechanism of Esophageal Speech. *Arch. Otolaryngol.* **15**: 479 (1932); Vicarious vocal mechanisms. *Archives of Otolaryngol.* **20**: 460-503 (1934).
- Kaplan, S.: Zur Frage der Stimmbildung bei Laryngektomierten. *Abstr. in Zentralbl. f. H.N.O.* **8**: 716 (1926).
- Kelleher, Hawlett and Parida: Glossopharyngeal breathing. *Brit. Med. Journ.* p. 740-743 (1957).
- Kenessey, L.: Speaking after laryngectomy. *Fül-Or. Gegl. Gyogy aszat.* **2**: 79 (1957).
- Mac Kenty, J. E.: Technique and after treatment of hemilaryngectomy and laryngectomy. *Journ. Am. Med. Ass.* **69**: 863-869 (1917); Laryngectomy with good speaking voice. *Laryngoscope* **30**: 112 (1920); Operation after total laryngectomy for cure of intrinsic cancer of the larynx. *Ann. of tol. Rhinol. Laryngol.* **31**: 1101-1117 (1922); Surgical treatment of laryngeal cancer with analysis of 70 cases. *New York State Med. Journ.* **22**: 456-462 (1922).
- McKesson, E. I. A.: A mechanical larynx. *Journ. Am. Med. Ass.* **88**: 645 (1927).
- Kindler, W. u. Ulich, K.: Das Geruchsvermögen bei Laryngektomierten. *Arch. Ohr- usw. Heilk.* **162**: 512 (1953).
- Klopfer, F.: Speech education for laryngectomized subjects. *Orvosi Hetilap* **91**: 27 (1950).
- Kneisner, Erika: Exper.-phonetische Untersuchungen an einem Fall von willkürlicher Aorophagie. *M. Ohrenheilk.* **66**: 431 (1932).
- Koepf-Baker, H.: The rehabilitation of the laryngectomized, *Transactions of American Academy of Ophthalmology and Otolaryngology* **52**: 227-233 (1948) with McDonald, E.: Rehabilitation of the laryngectomized. *The Crippled Child* **30**: 10-11 (1950).
- Krauss: Formation artificielle de la parole après extirpation du larynx. *Allg. Wien. Med. Zeitung.* **19** (1894).
- Landois u. Strübing: Erzeugung einer Pseudo-Stimme bei einem Manne mit totaler Extirpation des Kehlkopfes. *Arch. f. Klin. Chir.* **38**: 143 (1889).
- Larru, E.: New orientations in the treatment of cancer of the larynx. *Anales de la Real Academia Nacional de Medicina* **67**: 3 (1950).
- Lavoie, R.: Le cancer du larynx. *Laval Medical* **18**: 614-617 (1952).

- Lederer, F. L.: Audible speech following laryngectomy. Arch. O.L. **15**: 947 (1932); Early diagnosis of laryngeal carcinoma. Arch. O.L. **29**: 587 (1939).
- Legler, U.: Ein Weg zur schnellen Erlernung der oes-pharyngeale Ersatzstimme für Laryngektomierte. Archiv. f. Ohren-Nasen u. Kehlkopfheilk. **162**: 535 (1953).
- Leroux-Robert: La chirurgie dans le traitement des épithéliomes du larynx. Annales d'Otolaryngol. (1950) p. 217 and p. 521 (1956).
- Leroux, L., Maspétiol.: Partial horizontal laryngectomy in cancer of the base of the epiglottis. Annales d'Oto-Laryngologie **67**: 5 (1950).
- Levin, N. M.: Teaching the laryngectomized patient to talk. Archives of Otolaryngol. **32**: 299-314 (1940). Speech rehabilitation after total removal of the larynx. Am. Med. Ass. **149**: 1281-1286 (1952); Total laryngectomy and speech rehabilitation. Eye, Ear, N., Thr. Monthly **34**: 585 (1955).
- Lewis, F. O.: Laryngectomy with results in 17 cases. Annals of Otology, Rhinology and Laryngology, **33** 359-362 (1924).
- Lindsay, J. R., Morgan, R. H., and Wepman, J. M.: The cricopharyngeus muscle in esophageal speech. Laryngoscope **54**: 55-65 (1944).
- Loebell, H., Brahm, K.: Gibt es beim Normalen einem Glottis- bzw. Sphinkterverschluss beim Heben von leichteren Gewichten (20 Kg.) und wie steht der Kehlkopftotal-extirpierte den alltäglichen Belastungen gegenüber? Folia Phoniatr. **2**: 67-78 (1950).
- Luchsinger, R.: Beobachtungen u. Behandlung der Stimme nach chir.-röntgen. Therapie des Kehlkopfkrebesses. Schw. Med. Wschr. **50**: 561 (1939); Der Mechanismus der Sprech- u. Stimmbildung bei Laryngektomierten und die Übungsbehandlung, Pract. Otorhinolaryngol. **14**: 304-323 (1952).
- Lueders, O. W.: Evaluation of post-laryngectomy-program. Arch. Otolaryngol. **65**: 572 (1957).
- Maconie, A. C.: Diagnosis and modern treatment of malignant diseases of the larynx, Medical Press **225**: 77-81 (1951).
- Marco, J., Morera, H. and Gimenez, J. A.: Olfaction in laryngectomised patients. Acta O.L. **46**: 114-126 (1956).
- Marland, P. M.: A direct method of teaching voice after total laryngectomy. Speech **13**: 4-13 (1949).
- Marschik und Fröschels. Fall von Totalexstirpation des Kehlkopfes. Pharynxstimme u. Oesophagusatmung. M. Ohrenhkl. **63**: 581 (1929).
- Martin, H.: Selection of treatment in cancer of the larynx. Annals of Otology, Rhinology and Laryngology **50**: 723-734 (1941); Incidence of total laryngectomy. Annals of Otology, Rhinology and Laryngology **59**: 359 (1950); Esophageal speech. Annals of Otol. Rhinol. and Laryngol. **59**: 687-689 (1950).
- Marx: Patient mit Pharynx- und Larynxstimme. Medicin. Klin. **22**: 1127 (1926).
- Mason, Marie: The rehabilitation of patients following surgical removal of the larynx, J. of Laryngol. and Otol. **64**: 759-770 (1950).
- Matzker, J. und Thelen, P. O.: Über die Funktion der Bauchpresse bei fehlendem Glottisschluss. Zeitschr. f. Laryngol. Rhinol. u. Otol. **34**: 819-825 (1955).
- Mikell, J. S. e.a.: Neurofibroma of the larynx in a five year old child; laryngectomy, rehabilitation. Arizona Med. **11**: 167-168 (1954).
- Mikichi: Recherches morphologiques de l'influence de la pharyngectomie et de la laryngectomie sur la muqueuse nasale. Zibi Intoka Rinzyo **49**: 890 (1956).
- Miller, William: Esophageal speech solves a problem. Journal of Rehabilitation **17**: 7-9 (1951).
- Mikulicz: Mitt. a. d. Grenzgeb. d. Med. u. Chir. **12**: 569 (1903).
- Möckel, G. und Schlosshauer, B.: Kehlkopflose Sprache. Röntgenkinematographische Analyse der pseudosprache Laryngektomierter Patienten. Deutsche Med. Wochen-

- schr. **80**: 1244 (1955).
- Moolenaar-Bijl, A. J.: Spreken zonder larynx, Ned. Tijdschr. v. Geneesk. **91**: 118 (1947); Larynxlozen spreken weer. T. v. Log. en Phon. 1950; Some data on speech without larynx, **3**: 21-26 (1951); De spraak na larynxextirpatie. Ned. Tijdschr. v. Geneesk. **97**: 2379 (1953); The importance of certain consonants in oesophageal voice after laryngectomy. *Annals Oto-Rhino-Laryngol.* **62**: 979 (1953); Connection between consonant articulation and the intake of air in oesophageal speech. *Folia Phoniat.* **5**: 212-215 (1953).
- Morrison, W. W.: The production of voice and speech following total laryngectomy. Tr. of Amer. Laryngol., Rhinol. Otolaryngol. Soc. **37**: 27-37 (1931); and *Archives Otolar.* **14**: 413 (1931); Physical rehabilitation of the laryngectomized patient. *Archives of Otolaryngol.* **34**: 1101-1112 (1941) with Fineman, S.: The production of the pseudo-voice after total laryngectomy. Tr. Amer. Acad. of Ophthalm. **41**: 631-634 (1936).
- Mosher, H. P.: X-ray study of movements of the tongue, epiglottis, and hyoid bone in swallowing. *Laryngoscope* **37**: 235-262 (1927).
- Moulonguet A, et Garde, E. J.: La rééducation de la voix chez les laryngectomisés. *Ann. d'Otolar.* **61**: 70 (1944).
- Nadoleczny.: Die Stimme der Kehlkopfflosen. *Zeitschr. f. Hals-Nas- Ohr- Heilk.* **44**: 36 (1938).
- Negus, E.: Affectations of the cricopharyngeal fold. **48**: 847-858 (1938); Intrinsic cancer of the larynx. Review of a series of cases. *Proceedings Royal Society of Medicine* **40**: 515-522 (1947); Cancer of the larynx. *Medical Press* **224**: 491-494 (1950).
- Neuberger, F.: Zur Psychologie u. Soziologie der Laryngektomierten. *M. Ohrenheilk.* **85**: 198-218 (1951).
- New, G. B.: Summary of cancer of the larynx. *Laryngoscope* **61**: 523-529 (1951).
- Nussdorfer, R.: Late results in laryngectomy, social problems of laryngectomized persons. *Oto-rino-laringologica Italiana* **12**: 366-375 (1942).
- Nylén, C. O. and Drettner, B.: Esophageal speech and ventriloquism. *Pract. Oro-rhino. laryngol.* **19**: 570-575 (1957).
- Ogura, Joseph.: Laryngectomy and radical neck dissection for cancer of the larynx, *Transactions of American Academy of Ophthalmology and Otolaryngology* **56**: 786 (1951) with Bello, J.: Laryngectomy and radical neck dissection for carcinoma of the larynx, *Laryngoscope* **62**: 1-52 (1952).
- Orton, H. B.: Review of diseases of the larynx. *Laryngoscope* **50**: 158-163 (1940); Treatment of extensive carcinoma of the larynx. *Laryngoscope* **59**: 496-510 (1951).
- Osborne, A.: My experience of laryngectomies and esophageal speech. *Journal of Laryngology* **1**: 20-23 (1950).
- Pellegrini, V. M., and Ragolini, G.: Ricerche sulla fonazione dei laryngectomizzati. *Boll. della Mal. dell'Orr., Ulteriori osservazioni sulla fonazione dei laryngectomizzati.* *Ibid.* **72**: 365 (1954).
- Pellegrini, V.: On the so-called pseudo-glottis in laryngectomized persons. *Journ. of Laryngol. Otol.* **71**: 405 (1957) London; Sulle cause che possono impedire la rieducazione fonetica del laryngectomizzato. *Boll. d. Mal. Or. Gol. Nas.* **75**: 399-405 (1957).
- Perello, J.: La educacion foniatrica de los laryngectomizados. *Medicina Clínica* **17**: 251 (1951); Le problème de la voix chez les laryngectomisés. *Acta Oto-rhino-laring. Ibero-Americ.* **3**: 149 (1951); La voix du laryngectomisé. *Cours Internat. La Voix*, p. 517 (1953). El pronostico en la erigmofonia. *Acta Otorinolar. Iber. Amer.* **8**: 248-254 (1957).
- Pierangeli, C.: L'importanza del rifornimento inspiratorio dell'esofago nella voce dei

- laryngectomizzati. Arch. ital. Mal. Trach. **10**: 16 (1942).
- Podvinec, J.: Entstehung der Sprache bei Tracheotomierten und Laryngektomierten, Otolaryngol. slav. **4**: (1932).
- Poppert: Zur Frage der totalen Kehlkopfextirpation. Deutsche Medizin. Wochenschr. **19**: 833 (1893).
- Portmann, G.: Voix pharyngo-oesophagienne chez un laryngectomisé. Société Anatomique Clinique de Bordeaux, March 1924; with Pommez, J.: La voix oesophagienne, J. méd. Bordeaux **129**: 495 (1952).
- Ramsey, G. H. S., et al.: Cinefluorography, Radiology **52**: 684-690 (1949).
- Reinaud et Doïn: Travaux scientifiques 1926, p. 205.
- Rickenberg, H. E.: Laryngectomized speech, Archives of Otolaryngol. **58**: 421-424 (1953).
- Robe, E. Y., Moore, P., Andrews, A. H., and Holinger, P. H.: A study of the role of certain factors in the development of speech after laryngectomy. I. Type of operation; II. Site of pseudoglottis; III. Coördination of speech with respiration. Laryngoscope **66**: 173, 382, 481 (1956).
- Roelfsema, H. L.: Spraak zonder strottenhoofd. Geneesk. Tijdschr. (Ned. Indië) **68**: 191-193 (1928).
- Rousselot: La parole avec un larynx artificiel. La parole 1902.
- Romoneck, P. L.: Artificial and pseudo-voice following complete laryngectomy. Nebraska Med. J. **17**: 238-243 (1932); Reeducation of the voice following a complete laryngectomy for carcinoma of the larynx. Trans. Amer. laryng., rhin., otol., Soc. **37**: 514-517 (1931).
- Rosedale, R.: Laryngectomy. The Ohio Speech and Hearing Therapist **1**: 1 (1950).
- Rubaltelli: Archiv. Ital. Mal. trach. bronch. **3**: (1939); Assistenza medica e humana al laryngectomizzato. Annali Laringol. Ot. Rin. Faringol. **55**: 405 (1957).
- Sartorio, C. Bocca, E. Bozzani, V.: Controllo radiologico del luogo di formazione della Pseudoglottide in Laryngectomizzati rieducati (Nota preliminare) Bolletino della Società Italiana di Fonetica Sperimentale. Nov. 1950.
- Schall, L.: Psychology of laryngectomized patients. Archives of Otolaryngol. **28**: 581-584 (1938); Cancer of the larynx; 5 year results, Laryngoscope **61**: 517-522 (1951). Laryngectomy. Pennsylvania Med. Journ. **41**: 261 (1938); Reeducation of the laryngectomized. Trans. Am. Laryngol. Assoc. **71**: 96 (1950).
- Schär, Alfred: Bibliographisches Referat über Stimme u. Sprache der Laryngektomierten (1898-1923). Manusk. Phonet. Lab. der Univ. Hamburg. Registrierung oesophagealer Phonationsbewegungen, 1927.
- Schilling, R., and Binder, H.: Experimentalphonetische Untersuchungen über die Stimme ohne Kehlkopf, Archiv für Ohren- Nasen- und Kehlk. **115**: 235 (1926). Über die Pharynx- und Oesophagusstimme. Zentralblatt f. Hals-Nasen-Ohrenheilk. **9**: 893 (1927).
- Schlossbauer, B. u. Möckel, G.: Röntgenkinematografische Darstellung der Pseudosprache nach Laryngektomie. Arch. Hals-, Nas.- Ohr.- Heilk. usw. **165**: 581, 638 (1954); Folia Phoniat. **10**: 154-166 (1958).
- Schmid, H. Zur Statistik des Totalextirpation des Kehlkopfs im funktionellem Sinne: laute, verständliche Sprache. Archiv f. Chir. **38**: 132 (1889); Berl. Klin. Woch. p. 757 (1893)
- Schönhärl, E.: Münch. med. Wschr. 1952.
- Schouten, J. F.: De toonhoogtegeaarwording. Philips Techn. Tijdschr. **5**: 298 (1940).
- Scripture, E. W.: Speech without larynx. Journ. of Am. Med. Ass. p. 1601 (1913); J. Physiol. **50**: 397-403 (1916).
- Schwab, W.: Über morphologische und funktionelle Veränderungen am Atmungstrakt

- nach Laryngektomie. *Archiv. f. Ohren-Nasen- Kehlkopf heilk. usw.* **166**: 444-475 (1955); Röntgenkinematografische Untersuchungen über die Ersatzsprache nach Laryngektomie. *Acta Otorinolar. Iber. Amer.* **8**: 248-254 (1957); *Proc. 10th speech and voice therapy conf. Barcelona 1956*; with Ey, W. and Ulmer, W.: Die Lungenfunktion beim Kehlkopffösen. Dr. Alfr. Hüthig Verlag, Heidelberg (1958).
- Scuderi, R.: Variations of the temperature of the air in the trachea of laryngectomized. *Bolletino della Societa Italiana di Biologia Sperimentale*, **27**: 818-820 (1951).
- Scuri, D.: Meccanismo fonetico nei laringectomizzati. *Arch. Ital. di Otolaringol.* **42**: 318-337 (1931); *Symposium Phon. Padua. Déc.* (1951); Importance of conservation of epiglottis in laryngectomy for eventual reeducation of speech. *Arch. Ital. di Otolaringol.* **41**: 18-34 (1930); Reeducation after laryngectomy. *Arch. Ital. di Otolaringol.* **41**: 577-584 (1930).
- Seeman, M.: Speech and voice without larynx. *Casop. lèk. Česk.*, **61**: 369-372 (1922); Registrierung oesophagealer Phonationsbewegungen. *Vox* **9** (1927); Abstr. in *Journ. Am. Med. Ass.* **83**: 484 (1924); Movements of esophagus in phonation. *Casop. lèk. Česk.* **63**: 771-776, 984-994, 1011-1021 (1924); Phoniatische Bemerkungen zu Laryngektomie. *Arch. f. Klin. Chir.* **140**: 285-298 (1926); Methods of rehabilitation of voice and speech after laryngectomy. *Casop. Lèk. Česk.* (1951); Zur Pathologie der Oesophagusstimme. *Acta Otorinolar. Iber. Amer.* **8**: 274 (1957) and *Fol. Phoniati.* **10**: 44-50 (1958).
- Segre, R. y Ardissonne: Protesis mecanica para la fonacion de los laringectomizados. *Acta Otorinolaring. Ibero-Amer.* **4**: 169 (1950).
- Seiffert, A. Bildung einer Pseudoglottis bei einem Laryngektomierten. *Z. Laryngol. usw.* **19**: 358 (1930).
- Seiler, C.: A case of laryngeal stenosis with audible articulation, *Philadelphia Medical Times*, **18**: 199 (1888).
- Sheard, C.: Production of speech after laryngectomy. *S. Clin. North America* **12**: 959-965 (1932).
- Skyrock, Harold: Speech without a larynx. *Hygeia* **25**: 725-753 (1947).
- Sichel, D., and Klotz, V.: Tomographies de cancer du larynx. *Journal de Radiologie et d'Electrologie* **31**: 11-12 (1950).
- Simpson, W. L.: Treatment of cancer of the larynx with special reference to esophageal voice. *Memphis Medical Journal* **86**: 86-87 (1946).
- Sokolowsky, R. R.: Effect of extrinsic laryngeal muscles on voice production. *Archives of Otolaryngol.* **38**: 355 (1943).
- Solis-Cohen, J.: Return of voice after laryngectomy. *J. Am. Med. Ass.* **21**: 834-838 (1893); Ein Fall von usw. *Arch. f. Laryng.* **1**: 276 (1894).
- Steinthal: La parole sans larynx. *Med. corresp. Blatt d. Wurt. Arztl. Landesvereins.* **27**: (1912).
- Stern, H.: Grundprinzipien der Sprach- u. Stimmbildung bei laryngektomierten, nebst einem neuen Beitrag zum Mechanismus der Sprach u. Stimme derartig Operierten. *Wien klin. Wochenschr.* **33**: 540 (1920); Die Funktion des Magens als Luftkessel beim Mechanismus der Sprache und Stimme Laryngektomierter. *Gesellsch. F. Inn. Med.* **35**: 90 (1923); Weitere Untersuchungen über den Mechanismus usw. *Zentralbl. f. Hals- Nasen- Ohrenheilk.* **3**: 418 (1923); *Z. Hals- Nas- Ohren- Heilk.* **6**: 561-567 (1923); Beiträge zur Kenntniss usw. *Z. f. Laryngol.- Rhinol.- Otol.* **12**: 196 (1925); Demonstration eines Laryngektomierten Patienten mit besonders gut modulationsfähiger Stimme. *Wien. Klin. Woch.* **39**: 302 (1926); Der Mechanismus usw. bei Laryngektomierten. *Handbuch Denker-Kahler* **5**: 494 (Springer, Berlin 1929); Demonstration laryngektomierter Patienten. *Wien. med. Wochenschr.* **2**: 882 (1929); Kombiniertes Sprechmechanismus bei einem Laryngektomierten nach partieller Magen-

- resektion. M. Ohrenheilk. **66**: 1173 (1932); Das Tracheostoma als stimmgebender Apparat. Z. Hals-usw. Heilk. **37**: 389 (1935).
- Sternberg, H.: Z. f. Hals usw. Heilk. **7**: 432 (1924).
- Stetson, R. H.: Esophageal speech for any laryngectomized patient. Archives of Otolaryngology **26**: 132-142 (1937); Can all laryngectomized patients be taught esophageal speech?, Transactions American Laryngological Association **59**: 59-71 (1937); Esophageal speech: methods of instruction after laryngectomy. Archives Néerlandaises de Phonétique Experimental **13**: (1937); Speech rehabilitation after laryngectomy. Journal of Iowa Medical Society **35**: 433-435 (1945).
- Struben, W. H., van Gelder L.: Movements of the superior structures in the laryngectomized patient. Arch. Otolaryngol. **67**: 655-659 (1958).
- Strübing, P.: Pseudostimme nach Ausschaltung des Kehlkopfes speziell nach Extirpation desselben. Deut. Med. W. schr. (1888); Über Sprachbildung nach Ausschaltung des Kehlkopfes. Kirchows Archiv. (1890); De la parole articulée après extirpation du larynx. Arch. f. Path. u. Physiol. **122**: 189 (1891).
- Stupka, W.: Ein Phonationsphänomen an den Speisewegen. M. Ohrenheilk. **55**: 1694 (1921); (Festschr. Hajek).
- Sudeck, R.: Die Pharynxsprache bei Laryngektomierten. Deutsche Med. Woch. schr. **48**: 85 (1922).
- Symonds, J.: Total laryngectomy; indications for and results of the operation. Journal of Laryngol. Rhinol and Otol. **35**: 257-263 (1920); A note on the later history of 4 cases of total laryngectomy. Lancet **1**: 652 (1920).
- Tarneaud, J.: La voix du laryngectomisé. Annales d'Otolaryngol. **65**: 155-158 (1948).
- Tapia, R. G.: Recuperación del laringectomizado. Cadern. Cient. **4**: 605 (1954).
- Tato, Mariani, de Piccoli and Mirasov: Study of the sonospectrographic characteristics in the voice of laryngectomized patients. Acta Otolar. **44**: 431 (1954).
- Terracol, J.: Les maladies de l'oesophage. Ed. 2, Masson, Paris (1951).
- Templeton, F. E., and Kredel, R. A.: The cricopharyngeal sphincter- a roentgenologic study. Laryngoscope **53**: 1-12 (1943).
- Tezel, E. B.: Automatic return of speech after laryngectomy for cancer, Turk. Tib Cem. Med. **5**: 31 (1939).
- Thompson, St. Clair: History of cancer of the larynx. J. Laryngol. Otol. **54**: 61-87 (1939)
- Thornval, A.: The result of laryngectomies performed during the period from 1928 to 1945. Acta Otolar. **34**: 331 (1946).
- Tucker, Gabriel: Diagnosis and treatment of cancer of the larynx. Journal of American Medical Association **149**: 119-121 (1952).
- Ullmann, E. V.: Über Beziehungen des Riechvermögens zum Kehlkopf, zugleich ein Beitrag zur Physiol. des Riechaktes. Zeitschr. f. Hals- Nas.- u. Ohrenheilk. **6**: 570 (1923).
- Vándor, F.: Röntgen Untersuchungen bei Laryngektomierten. Fortschr. Röntg. str. **82**: 618 (1955).
- Vokoun, F. J.: Resection of the larynx without loss of the voice. Mil. Surgeon **69**: 617 (1931).
- Voorhoeve, N.: Der Magen als vikariierender Luftkessel nach Laryngektomie. Acta radiologica **7**: 587-594 (1926).
- Wedler, H. W. und Schwab, W.: Das Röntgenbild des Hypopharynx nach Laryngektomie. Arch. Ohr- Nas.- Kehlk.-Heilkde. **168**: 8 (1955).
- Weersma, P.: Spraak zonder larynx. Ned. Tijdschr. v. Geneesk. **84**: 3070 (1940).
- Wegel, R. L.: Mechanics of larynx, natural and artificial. Tr. 36th Ann. Meeting Am. Laryngol., Rhinol. and Otol. Soc. 309-320 (1930).
- Weiss, D., and Grünberg, M. Roentgenography of normal phonation and that of

- laryngectomized patients, Bulletin Soc. Belge d'Oto-Rhino-Laryngol. 373-383 (1939).
- Wepman, J. M. e.a.: The objective measurement of progressive esophageal speech development. *J. Speech and Hearing Disorders* **18**: 247-251 (1953).
- Wessely, V. E.: Verschlussplastik eines Laryngotracheostomas mit Wiederherstellung der normalen Sprechstimme, *M. Ohrenheilk.* **78**: 1145 (1936).
- Wetherhill: Retour de la voix après une laryngectomie totale. *Ann. Malad. Oreille* (1894) p. 10.
- Wildenberg, van den: La laryngectomie totale chez un octogénaire, *Acta Otorhinolar. Belgica* **5**: 362 (1951); What rehabilitation can do. *Speech without a larynx, Hospital Progress* **31**: 237-241 (1950).
- Winckel: Elektroakustische Untersuchungen. *Folia Phon.* **4** (1952).
- Wright, E. S.: Diagnosis and treatment of cancer of the larynx, *Annals Otol.*, **51**: 228 (1942).
- Wynder, E. L., Bross, I. J. and Day, E.: Epidemiological approach to the etiology of cancer of the larynx. *J. Am. med. Ass.* **160**: 1384 (1956).
- Zinn, W. F.: Laryngectomy. *Trans Amer. lar. rhin., ot. Soc.* **39**: 471 (1933).

FILMS

- The rehabilitation of laryngectomized patients. Prod. by L. A. Schall. (1949).
Disc. in *Journ. Am. Med. Ass.* **142**: 438 (1950).
- New voices. Produced by Cleveland Hearing and Speech Center, 1951.
- We speak again. Produced by Sturgis-Grant Productions, New York, 1951.
- Oesophageal Speech. J. W. van den Berg, A. J. Moolenaar-Bijl, P. H. Damsté (1955).
- Röntgenkinematografische Untersuchungen über die Ersatzsprache nach Laryngektomie. W. Schwab (1956).
- Röntgentonfilm der Oesophagusstimme. Schlosshauer und Möckel (1956).
- Moore, P., Holinger, P., Robe, E.: Films sur le mouvement de l'oesophage chez les laryngectomisés. *Annales d'Otolaryngol.* **73** (1956).

