

University of Groningen

Pediocin PA-1, a wide-spectrum bacteriocin from lactic acid bacteria

Rodriguez, JM; Martinez, MI; Kok, Jan

Published in:
Critical Reviews in Food Science and Nutrition

DOI:
[10.1080/10408690290825475](https://doi.org/10.1080/10408690290825475)

IMPORTANT NOTE: You are advised to consult the publisher's version (publisher's PDF) if you wish to cite from it. Please check the document version below.

Document Version
Publisher's PDF, also known as Version of record

Publication date:
2002

[Link to publication in University of Groningen/UMCG research database](#)

Citation for published version (APA):

Rodriguez, J. M., Martinez, M. I., & Kok, J. (2002). Pediocin PA-1, a wide-spectrum bacteriocin from lactic acid bacteria. *Critical Reviews in Food Science and Nutrition*, 42(2), 91-121. DOI: 10.1080/10408690290825475

Copyright

Other than for strictly personal use, it is not permitted to download or to forward/distribute the text or part of it without the consent of the author(s) and/or copyright holder(s), unless the work is under an open content license (like Creative Commons).

Take-down policy

If you believe that this document breaches copyright please contact us providing details, and we will remove access to the work immediately and investigate your claim.

Downloaded from the University of Groningen/UMCG research database (Pure): <http://www.rug.nl/research/portal>. For technical reasons the number of authors shown on this cover page is limited to 10 maximum.

Pediocin PA-1, a Wide-Spectrum Bacteriocin from Lactic Acid Bacteria

Juan M. Rodríguez,^{1,*} María I. Martínez,¹ and Jan Kok²

¹Departamento de Nutrición y Bromatología III, Universidad Complutense de Madrid, 28040 Madrid, Spain;

²Department of Genetics, Groningen Biomolecular Sciences and Biotechnology Institute, University of Groningen, 9751 NN Haren, The Netherlands

Referee: Dr. Helen Dodd, Food Safety Science Division, Institute of Food Research, Norwich Research Park, Colney NR4 7UA, Norwich, United Kingdom

* Corresponding author.

ABSTRACT: Pediocin PA-1 is a broad-spectrum lactic acid bacteria bacteriocin that shows a particularly strong activity against *Listeria monocytogenes*, a foodborne pathogen of special concern among the food industries. This antimicrobial peptide is the most extensively studied class IIa (or pediocin family) bacteriocin, and it has been sufficiently well characterized to be used as a food biopreservative. This review focuses on the progress that have been made in the elucidation of its structure, mode of action, and biosynthesis, and includes an overview of its applications in food systems. The aspects that need further research are also addressed. In the future, protein engineering, genetic engineering and/or chemical synthesis may lead to the development of new antimicrobial peptides with improved properties, based on some features of the pediocin PA-1 molecule.

KEY WORDS: pediocin PA-1, bacteriocins, lactic acid bacteria, food preservatives, antimicrobials, food safety, *Listeria monocytogenes*.

I. INTRODUCTION

Bacteriocins of lactic acid bacteria (LAB) are attractive to the food industry because they may be used as natural biopreservatives and contribute to the improvement of the microbiological quality of foods.¹ Also, the use of these ribosomally synthesized antimicrobial peptides may allow a significant reduction in the level of chemical additives and/or in the intensity of the physical treatments currently employed during food processing. Therefore, they could also help to provide healthier foods.²

Since the late 1920s, when the first reports on the antimicrobial activity of a lactococcal bacteriocin (later called nisin) were made, a large number of LAB bacteriocins have been identified, particularly in the last few years. On a scientific basis, LAB bacteriocins can be divided into three main classes:^{3,4} class I (lantibiotics), class II (small heat-stable nonlantibiotics), and class III (large heat-

labile bacteriocins). Class IIa, one of the subgroups in which class II bacteriocins may be divided, is also termed the “*pediocin family*” after the first and most extensively studied representant of this class, pediocin PA-1.⁴ Members of this subgroup (“*pediocin-like*” bacteriocins) show very strong antilisterial activity and have 40 to 60% sequence similarity (Table 1). The N-terminal region is particularly well conserved and contains a conserved “*pediocin box*” motif (YGNGVXCXK).⁵

Nisin is currently the only bacteriocin licenced as a food additive in over 45 countries.⁶ However, several studies have shown that there are other LAB bacteriocins with potential for use as food preservatives, particularly class IIa bacteriocins due to their antilisterial activity.⁷ In fact, the biopreservative potential of pediocin PA-1 has already been commercially exploited. The pediocin PA-1-containing fermentate Alta™ 2341 is a commercial food ingredient reported to extend the shelflife of a variety of foods and, particularly, to

TABLE 1
Amino Acid Sequences of Class IIa Bacteriocins^a

Pediocin PA-1	KYYGNGVTGKHS ^c SDWGKATTCIINN ^c GAMAWATGGHQGNHKC
Enterocin A	TTHSGKYYGNGVYCTKNKCTVDWAKATTCIAGMSIGGFLGGAIPGKC
Sakacin P	KYYGNGVHCGKHSCTVDWGTAGNIGNNAAANWATGGNAGWNK
Curvacin A	ARSYNGVYCNKKCWNRGEATQSIIGGMISGWASGLAGM
Piscicolin 126	KYYGNGVSCNKGCTVDWSKAIGIIGNNAAANLTTGGAAGWNKG
Leucocin A	KYYGNGVHCTKSGCSVNWGEAFSAGVHRLANGGNGFW
Mesentericin Y105	KYYGNGVHCTKSGCSVNWGEAASAGIHRLANGGNGFW
Carnobacteriocin B2	VNYGNGVSCSKTKCSVNWQAFQERYTAGINSFVSGVASGAGS ^c IGRRP
Carnobacteriocin BM1	AISYNGVYCNKEK ^c CWNKAENKQAITGIVIGGWASSLAGM ^c GH
Bavaricin MN	TKYYGNGVYXNSKKXWVDWQAAAGGIGQTVVXGWLGGAI ^c PGK
Bacteriocin 31	ATYYGNGLYCNKQK ^c CWVDW ^c NKASREIGKIIIVNGWVQHGPWAPR
Enterocin P	ATRSYNGVYCNNSK ^c CWVNWGEAKENIAGIVISGWASGLAGM ^c GH
Divercin V41	TKYYGNGVYCN ^c SKK ^c CWVDWQASGCGIGQTVVGGWLGGAIPGKC
Consensus sequence ^b	KYYGNGV.C.K..C.V.W..A...I

^aAdapted from Eijsink *et al.*²⁶ ^bUnderlined letters represent 100% conserved residues. Sakacin P is identical to bavaricin A, curvacin A to sakacin A and carnobacteriocin BM1 to piscicocin V1b.²⁶

inhibit the growth of *Listeria monocytogenes* in ready-to-eat meat products.

In the past, several pediocin PA-1-producing LAB strains were independently isolated in different labs.⁸⁻¹⁹ However, in many cases the bacteriocin produced received different names (e.g., pediocins PA-1, AcH, JD, Bac and 347, mesentericin 5) before identification and realization that all were the same molecule. As it is desirable to conform to a uniform nomenclature,¹ the more widespread name, pediocin PA-1, has been adopted for this review.

Despite the fact that pediocin PA-1-producing LAB have been inadvertently or empirically used as starter cultures for many years, most of the current knowledge on pediocin PA-1 has been generated since 1992. In that year, the determination of the pediocin PA-1 amino acid sequence,²⁰⁻²¹ the application of improved protocols for its purification,²¹ and the identification of the pediocin PA-1 operon,²²⁻²³ greatly facilitated research on this subject. In addition, the continuous development of new and improved biotechnological tools have favored the increasing number of studies dedicated to this bacteriocin. The purpose of this article is to review the now enormous literature on an antimicrobial peptide with such industrial potential. Advances in the understanding of its structure, mode of action, and biosynthesis will be highlighted. Following that, we discuss the development of methods that allow its specific detection and quantification. The results of the studies involving application of pediocin PA-1 in food substrates will also be presented. Finally, the last part of this review exposes the main conclusions and future prospects of this interesting antibacterial peptide.

II. PHYSICOCHEMICAL PROPERTIES

A. Structure

The primary structure of pediocin PA-1 has been determined by Edman degradation of the purified peptide and by sequence analysis of the structural gene.²⁰⁻²³ Pediocin PA-1 is a 44 amino acid peptide with no posttranslational modifications.²⁰⁻²¹ The primary structure seems enough to

induce toxicity on sensitive cells as synthetic pediocin is biologically active and has a specific activity comparable to that of the natural form.²⁴ Other remarkable characteristics of the molecule are the absence of phenylalanine, leucine, glutamine, or arginine residues and the presence of four lysine and three histidine residues and only one aspartate. Titration of free cysteine residues with Ellman's reagent, tryptic cleavage patterns, mass spectrometry data, and pediocin reduction in the presence of dithiothreitol (DTT) have provided evidence for the four cysteine residues forming two disulfide bonds (C₉-C₁₄ and C₂₄-C₄₄),^{20,24-26} which are also spontaneously formed in synthetic pediocin PA-1.²⁴ As a reflection of its amino acid composition and sequence, pediocin PA-1 is a cationic peptide with a basic pI. Values ranging from +7 to +3 have been reported for the net charge at pH 6,^{1,27,28} and from 8.6 to 10 for the pI.^{1,20,21,29} A comparison of the primary structures of the pediocin-like bacteriocins suggests that their polypeptide chains can be divided into two functional modules, a conserved hydrophilic N-terminal β -sheet and a more diverse hydrophobic or amphiphilic C-terminal α -helical domain^{24,30} (Table 1).

Initially, the secondary structural organization of the peptide was predicted by Henderson et al.²⁰ following primary sequence analysis by Chou-Fasman and Kyte-Coolite protocols. It is proposed that the structure would consist of random coils and β -turns with a propensity of residues A₂₁ through I₂₅ for a β -sheet and a primarily hydrophilic profile except for the predicted β -sheet area. In addition, the fragment T₂₂ to A₃₄ that contains the single tryptophan and methionine residues would define a hydrophobic region in close spatial proximity with the C-terminus due to the disulfide bond C₂₄-C₄₄.

More recently, Chen et al.²⁷ predicted the pediocin PA-1 secondary structure on the basis of single and multiple sequence alignments and built a model for its 19 N-terminal amino acids. The model consisted of two β -strands connected by a tight 4-residues β -hairpin. The N-terminal β -turn would include the consensus sequence (YGNGV) of class IIa bacteriocins, and the tip of the β -hairpin would contain two positively charged residues (K₁₁ and H₁₂). The C₂₄-C₄₄ disulfide bond

would bring together H₄₂, K₄₃, and possibly K₂₀. NMR data had previously shown an ordered β -structure in the vicinity of the two cysteine residues (C₉ and C₁₄) of leucocin A, another class IIa bacteriocin.³¹ Figure 1 shows a model of the pediocin PA-1 structure.

B. Molecular Weight

The theoretical molecular weight of pediocin PA-1, calculated from the amino acid sequence, could be 4628 or 4624 Da, in the absence or presence of two disulfide bonds, respectively.^{20,24} Experimental determination of the molecular weights of natural and synthetic pediocin by electrospray mass spectrometry revealed that the cysteine residues are oxidized and joined by two disulfide bonds.^{16,17,24} Previously, a molecular weight of approximately 16,500 had been estimated by gel filtration of a partially purified sample. This value was nearly an exact multiple of the actual molecular weight, suggesting the presence of a stable tetramer.⁸

C. Solubility and Stability

The fact that many studies on pediocin PA-1 solubility and stability have been performed with partially purified samples makes it difficult to directly compare results obtained by different authors.

Pediocin PA-1 is stable in dilute aqueous solutions, although the molecules can form active aggregates and tend to do so more readily as the pediocin concentration increases and at refrigeration temperatures.¹⁰ Aggregation seems to involve components of the growth medium rather than being an autocatalytic process because in contrast to pediocin PA-1 in supernatants or to partially purified samples, the homogeneous peptide does not aggregate even at high concentrations.²⁰

Samples containing pediocin PA-1 retained total or partial activity after exposure for 24 h to pH values ranging from 2 to 10 at room temperature, although the highest stability was achieved between pH 4 and 6.^{8,10} Evaluation of the residual activity after storage at 15°C of a culture extract

from *Lb. plantarum* WHE 92 showed that pediocin PA-1 was perfectly stable after 21 days when the pH of the extract was maintained at 4, 5, or 6, but half of the activity disappeared at pH 7.¹⁷ Although antimicrobial activity was unaffected by heating at 80°C for 60 min and at 100°C for 10 min, the effect of a treatment at 121°C for 15 min is controversial as values of residual activity of 6%⁸ and 60%¹⁰ have been reported. Freezing (−25°C) or refrigeration (0 to 8°C) storage did not reduce the activity of pediocin samples after 6 months and 12 weeks, respectively.³² In contrast, activity was stable at room temperature (22 to 25°C) for 6 weeks, but then it progressively decreased and over 50% was lost in 12 weeks.³² Recently, it has been shown that purified pediocin PA-1 stored at 4 and 25°C is stable at pH 5 but not at pH 7, while it remains stable after storage at −20°C at both pH values.³³

Pediocin PA-1 activity is unaffected by treatment with phospholipase C, catalase, lysozyme, Dnases, Rnases, or lipases but is lost after incubation with proteolytic enzymes such as trypsin, papain, ficin, α -chymotrypsin, protease IV, protease XIV, protease XXIV, and proteinase K.^{8,10,34} Pediocin activity rapidly decreased when monitored in a culture of *Lb. plantarum* WHE 92, most probably because of hydrolysis by proteolytic enzymes produced at the end of the exponential growth phase.¹⁷ As a result, the percentage of residual activity ranged from 1 to 6% after 21 days of incubation at 15°C. The absence of contaminating proteases may also explain why synthetic pediocin is more stable than the molecule isolated from the natural source.²⁴

After storage in 30% acetonitrile-0.1% trifluoroacetic acid (TFA) for 1 week or more at −15°C, pediocin molecules became oxidized, showing a molecular weight increase of 16 or multiples of 16.¹⁶ Similarly, after storage in 30% 2-propanol-0.1% TFA for 8 months at 4°C, about 50% of natural and synthetic pediocin had been transformed to a more hydrophilic and less active form (pediocin PA-1-ox).²⁴ The pediocin PA-1-ox molecular weight had increased by 16 relative to that of pediocin PA-1 and had suffered a 100- to 200-fold reduction in its specific activity. The oxidation of the sulfur atom of the methionine residue of pediocin PA-1, and its transformation

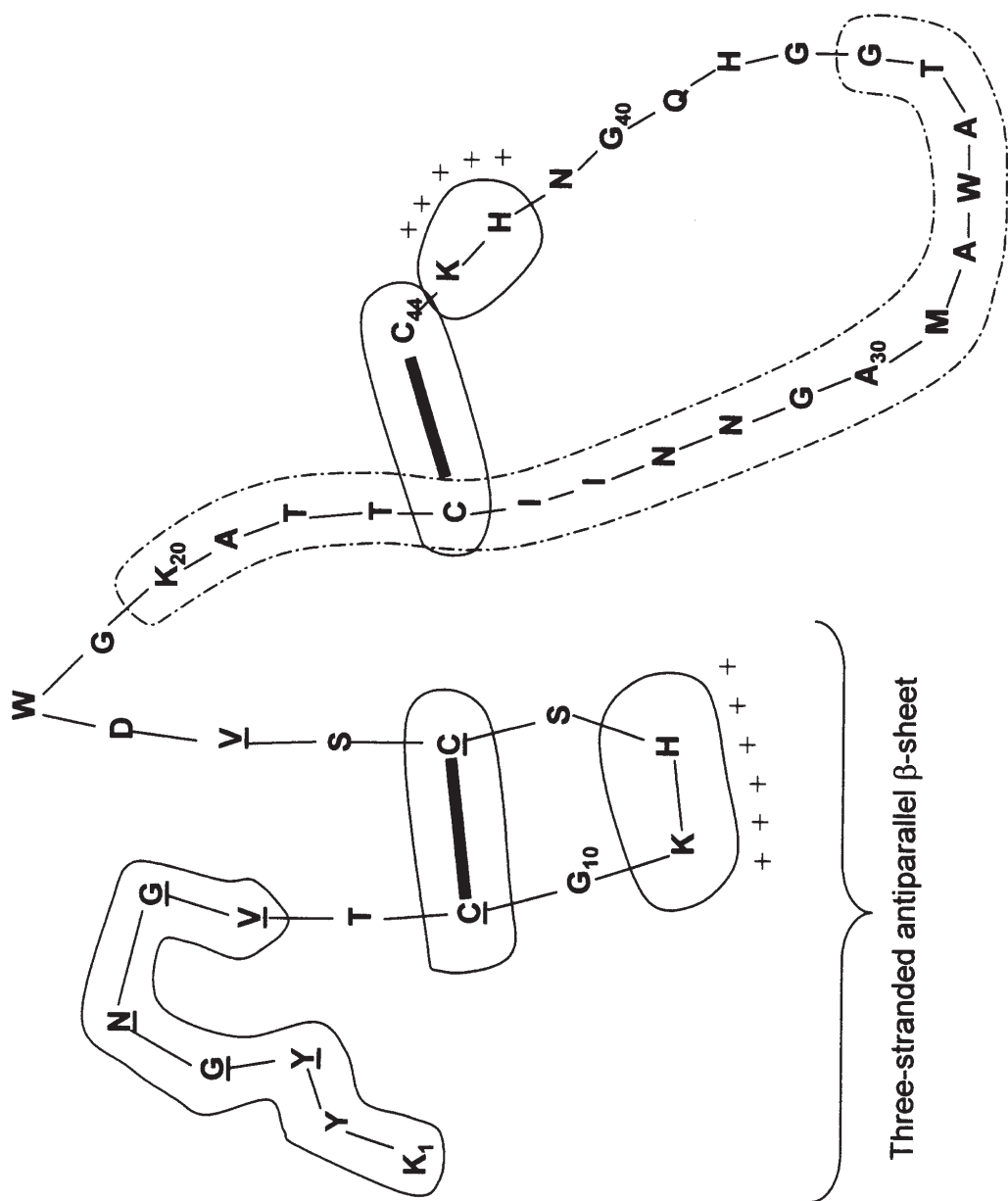

FIGURE 1. Structure of a pediocin PA-1 molecule showing those features that are (putatively) important for its biological activity. The residues 100% conserved among class IIa bacteriocins are underlined. Residues contained within a solid line (———) are essential for antimicrobial activity; residues contained within a broken line (- - - - -) are important for determining target cell specificity; (+), positive patch; (———), disulfide bond.

to sulfoxide in the pediocin PA-1-ox molecule may explain the increase in molecular weight and hydrophilicity without charge alteration.²⁴ Recently, site-directed mutagenesis studies were performed to obtain methionine-free pediocin PA-1 variants.³³ Although mutating Met₃₁ to Asp nullified bacteriocin activity, other methionine-free pediocin PA-1 variants (Met₃₁ to a hydrophobic amino acid, such as Ala, Leu, or Ile) displayed higher storage stability without a concomitant large loss of activity.

D. Purification

Because pediocin PA-1 is a secreted peptide, most of the purification protocols start with the concentration of cell-free supernatants obtained from the producing strains prior to the application of chromatography-based techniques.

Initially, Gonzalez and Kunka⁸ partially purified pediocin PA-1 by ammonium sulfate precipitation and two successive ion-exchange chromatographic steps of the reconstituted dialyzed precipitate. However, no data were provided on the evolution of the specific activity through the purification process. After a similar precipitation step, Bhunia et al.¹⁰ employed gel filtration and anion-exchange chromatographies, both integrated in an FPLC system. The activities of the final fractions were up to 98 times higher than those of the respective supernatants.

The ability of this bacteriocin to adsorb to the cell envelope of the producing cells was the basis of the purification method developed by Yang et al.³⁵ These authors adjusted the pH of a fully grown culture to pH 6, a value coincident with the highest adsorption efficiency. Then, cells were collected by centrifugation and the pH of the cell suspension was readjusted to 2 for bacteriocin release. The suspension was applied to a reverse-phase column coupled to an HPLC system and 106% of the initial activity was recovered. Daba et al.¹⁶ followed a similar approach and the elution profile revealed two peaks with antimicrobial activity. The large HPLC peak corresponded to pediocin PA-1, while the minor peak contained oxidized forms of the bacteriocin.

In 1992, Henderson et al.²⁰ purified pediocin PA-1 to homogeneity by successive gel filtration of the supernatant, ion-exchange chromatography, dialysis and, finally, reverse-phase chromatography coupled to HPLC. Although the yield was only 0.6%, the final sample was pure enough to allow pediocin PA-1 amino acid sequencing. Simultaneously, Nieto-Lozano et al.²¹ also purified this bacteriocin to homogeneity and sequenced it. Their purification procedure, with a significantly higher activity yield (600%), included ammonium sulfate precipitation, followed by three chromatographic steps (cation-exchange, hydrophobic interaction, and reverse-phase chromatography, respectively).³⁶⁻³⁷ This basic protocol, with slight modifications, has been widely and successfully applied for the purification of a large number of LAB bacteriocins. Usually, the final reverse-phase chromatography step is repeated two or three times to ensure maximum purity. In addition, the use of large volumes of washing buffer for the washing steps during ion-exchange and hydrophobic interaction chromatographies may contribute considerably to purity,²⁶ while a gel filtration step prior to the cation-exchange chromatography may increase the purification yield.³⁸⁻⁴¹ Recently,⁴² another chromatography-based method consisting in three steps (ion-exchange, solid phase extraction, and reverse phase HPLC) has been applied successfully to obtain highly pure class IIa bacteriocins, including pediocin PA-1.

Pediocin PA-1 has also been purified by a protocol, including ethanol precipitation, preparative isoelectric focusing, and ultrafiltration.²⁹ About 32% of the pediocin contained in the culture supernatants was precipitated with cold ethanol. Almost no activity (3%) was lost during isoelectric focusing and all activity remained after ultrafiltration. The major advantage of this method was the omission of chromatography steps, avoiding losses due to bacteriocin sticking to the matrix of the columns.

Ideally, the methods used for bacteriocin purification should have high final yields, low costs, and a high reproducibility. The purification protocols cited above involve several steps that make the process inefficient, laborious, and/or expensive, especially if scaling-up for industrial purposes is desired. Construction of immunoaffinity columns using

pediocin PA-1-specific-antibodies may constitute an alternative approach for the simple (even single-step) purification of pediocin PA-1. Nisin monoclonal antibodies⁴³ were used successfully for the one-step purification of this lantibiotic in 5 ml immunoaffinity columns, although scaling-up has not been evaluated yet.⁴⁴ In this context, the recent generation of polyclonal antibodies that specifically recognize pediocin PA-1 is a promising step.^{40,41}

III. BIOLOGICAL PROPERTIES

A. Antimicrobial Spectrum

Pediocin PA-1 displays antimicrobial activity against a wide spectrum of Gram-positive bacteria, many of them responsible for food spoilage or foodborne diseases. The activity of pediocin PA-1 against *Listeria monocytogenes*, a microorganism with the highest mortality rate among foodborne bacteria in Western Europe and North America, is particularly relevant. Therefore, many studies on the biological activity of this peptide have been focused on its effects on *L. monocytogenes* cells.⁴⁵ Interestingly, pediocin PA-1 is not active against bacteria used frequently in starter cultures, such as lactococci. Pediocin PA-1 has similar MIC values at 20, 30, and 37°C, and its C-terminal disulfide bridge is a major determinant of the antimicrobial spectrum.⁴⁶ The structure and composition of the outer membrane of Gram-negative bacteria do not allow pediocin access to its target, the cytoplasmic membrane. However, many Gram-negative organisms (such as *Salmonella typhimurium*, *Escherichia coli*, *Serratia liquefaciens*, and *Pseudomonas fluorescens* strains) are pediocin PA-1-sensitive after inflicting sublethal injuries (like freezing, gentle heating, exposure to lactic acid or EDTA, or hydrostatic-pressure pasteurization) to the outer membranes, rendering their cytoplasmic membranes accessible to pediocin molecules.⁴⁷⁻⁵¹

B. Quantification of the Antimicrobial Activity

Currently, the agar diffusion test is one of the most widely used methods to detect bacteriocin

activity. Several arbitrary units have been defined to quantify the antimicrobial activity of pediocin PA-1 on solid media. Bhunia et al.¹⁰ employed “antimicrobial activity units” (AAU) calculated as the reciprocal of the antimicrobial titre multiplied by the dilution factor and divided by the protein concentration (in mg) determined by the Lowry method. The titre was defined as the reciprocal of the highest dilution producing a clear zone of inhibition of 2 mm or larger on an *Lb. plantarum* WSO-39 lawn.⁵² Later, Gonzalez and Kunka⁸ defined one “arbitrary unit” (AU) of bacteriocin as 5 µl of the highest dilution of culture supernatant yielding a definite zone of growth inhibition on a lawn of the indicator *P. pentosaceus* FBB63. This unit was also adopted by other authors.^{20,53-55}

Turbidometric methods, such as the microtitre plate assay,^{36,56} are also used to detect and quantify pediocin activity.^{19,21,38-40} In this system, one bacteriocin unit (BU) is defined as the reciprocal of the sample dilution, which inhibits growth of the indicator organism by 50%, as indicated by spectrophotometric measures. This method is very useful to evaluate the activity of the different fractions obtained during pediocin PA-1 purification.

In contrast to nisin, there is no international unit referring to the activity of an international reference sample of pediocin PA-1. It is impossible to compare arbitrary antimicrobial activity values in cultures, culture supernatants, or (partially) purified pediocin PA-1 obtained by different authors, even if they use the same assay, because the MICs values for vegetative cells and spores may significantly differ depending on the producing or indicator strains, the sample preparation method, and the bacteriocin assay conditions.⁵⁷ In addition, the major drawback of the assays cited above is their unspecificity. In this context, the recent development of pediocin PA-1 specific polyclonal antibodies enables the specific quantification of the pediocin present in a sample by using a wide array of immunoassay formats.^{40,41}

Detecting a specific bacteriocin by searching for a compound with a determined molecular mass may be a practical approach to confirm the presence of pediocin PA-1 in cultures or foodstuffs.

Matrix-assisted laser desorption/ionization time-of-flight mass spectrometry (MALDI-TOF MS) has been used recently for rapid detection of pediocin PA-1, nisin, brochofocins A and B and enterocins A and B, from culture supernatants.⁵⁸ Compared with other spectrometric techniques, MALDI-TOF MS offers some advantages for the routine analysis of bacteriocins, including ease of use, picomolar to femtomolar sensitivity, high mass range, ability to give extremely accurate mass values, and relative tolerance to sample contaminants.⁵⁸

C. Resistance to Pediocin PA-1

The emergence of organisms highly tolerant or naturally resistant to class II bacteriocins has become quite common and is a potential obstacle to their application as food biopreservatives.⁵⁹ Although the ecology and mechanisms of resistance to many traditional antibiotics have been studied profusely, little is known on these aspects in the bacteriocin field.^{60,61} However, investigations on this subject will rapidly increase in the near future because of the industrial interest in the application of bacteriocins and/or bacteriocinogenic LAB to improve the microbiological quality of foods.

Sensitivity to pediocin PA-1 differs greatly between species and strains evaluated,^{18,59,62} although pediocin PA-1-resistant or -tolerant strains seem to occur more frequently than strains displaying resistance or tolerance to nisin.⁵⁹ Growth of surviving cells of *L. monocytogenes* strains in pediocin PA-1-treated foods during refrigeration storage (4 and 10°C) has been reported,^{53,62} and the population levels of some strains reached very high numbers in a short time,⁶² even in the presence of residual pediocin. As reduction in *Listeria* counts was greater with higher levels of pediocin, it has been suggested that the level of pediocin (or other bacteriocins) should be adjusted to obtain maximum viability loss of the most resistant strain when used as a food preservative.⁶² Probably, the routine use of pediocin PA-1 at concentrations not high enough to eradicate all *Listeria* cells may result in emergence of populations resistant not only to pediocin but also to other closely related bacteriocins.⁶³ The effect

of pediocin was higher when the initial *Listeria* population was lower,⁶² a fact confirmed by a later study that showed complete inhibition of *Listeria* cells on refrigerated chicken meat by pediocin treatment.⁶⁴ These results emphasize the importance of effective measures to prevent or minimize food contamination.

Noerlis and Ray⁶⁵ described how a non-pediocin producer *P. acidilactici* strain (obtained after loss of the plasmid harbouring the pediocin PA-1 operon) became resistant to this bacteriocin while growing in its presence. However, this study also indicated that the acquired resistance was a transient trait because it was soon lost after subculturing (five subcultures) in a pediocin PA-1-free medium. Similarly, Dykes and Hastings⁶¹ studied the fitness costs associated with class IIa bacteriocin resistance in one *L. monocytogenes* strain and found that the resistant strain had a lower growth rate than the sensitive one in monocultures, and, furthermore, that resistant cells were unable to invade populations of the sensitive variants when grown in mixed cultures. The authors concluded that this specific class IIa bacteriocin resistance was unlikely to become stable in natural populations of that particular *L. monocytogenes* strain. However, this study may not reflect the general situation because only one resistant strain was tested. In contrast, the resistance to other LAB bacteriocins has been shown to be stable during at least 10 generations in the absence of contact with bacteriocins.⁶⁶

Involvement of cell wall constitution and membrane lipid composition in acquired bacteriocin resistance has been suggested frequently.⁶⁷⁻⁷⁰ The fact that stability of the resistance phenotype can vary and may or may not be lost after subculturing in the absence of the bacteriocin indicates that a more general adaptive response may also be involved in trained bacteriocin resistance.¹⁸ Bennik et al.¹⁸ studied the relationships between membrane lipid properties and the effect of pediocin PA-1 and nisin on glycolysis, intracellular ATP pools, and membrane potential of whole LAB cells. Their results indicate that not only membrane lipid composition, but also overall membrane constitution may play an important role in determining LAB susceptibility toward these bacteriocins. These authors suggested that although LAB strains with

a natural high resistance toward a bacteriocin cannot avoid the membrane insertion of bacteriocin monomers, the overall composition of the membranes may preclude the formation of pores with sufficient diameters and lifetimes to cause cell death (see mode of action).

Combination of pediocin PA-1 with other bacteriocins may constitute one approach to avoid the growth of resistant cells. A mixture of nisin and pediocin PA-1 was bactericidal to more cells in an initially sensitive population, probably because cells resistant to one bacteriocin were killed by the other.⁷¹ The combination killed more cells of two LAB and two *L. monocytogenes* strains than each bacteriocin individually. In addition, the mixture inhibited growth of all clostridial strains tested for up to 28 days, while pediocin or nisin alone produced variable results. Recently, the additive effect of applying pediocin PA-1 in combination with bacteriocins belonging to unrelated classes has been reported,⁷² demonstrating that, in addition to nisin A, it can act synergistically with lacticin 481, lacticin B, or lacticin F. In contrast, when pediocin PA-1 was combined with other class IIa bacteriocins, no synergistic effects were observed.²⁶

The fact that pediocin PA-1 is, structurally and functionally, completely unrelated to nisin, lacticin 481, lacticin B, or lacticin F may have practical consequences. Different authors^{59,66} have reported that although *L. monocytogenes* mutants with spontaneously acquired resistance to one class II bacteriocin also displayed cross-resistance to other members of this bacteriocin class, their sensitivity to nisin had not been affected. Sakacin P (a class IIa bacteriocin) sensitivity among 22 strains of *L. monocytogenes* directly correlated with the pediocin PA-1 sensitivity of the strains. In another study,⁶³ *Listeria* cells surviving nisin action were pediocin PA-1 resistant, while pediocin PA-1 survivors remained susceptible to the lantibiotic. The beneficial synergistic effects resulting from the combination of unrelated LAB bacteriocins can be exploited to extend their potential application in the food industry.

D. Mode of Action

The bactericidal mode of action of pediocin PA-1 on sensitive cells involves three basic steps:

pediocin binding to cytoplasmic membranes, insertion of bacteriocin molecules in the membranes, and formation of the poration complex. This process finally leads to cell death that may occur with or without cell lysis, probably depending on concomitant activation of the cell autolysins. For a review on the mechanism of action of pediocin PA-1 see Reference 73.

Initially, Gonzalez and Kunka⁸ showed that pediocin-sensitive or pediocin-insensitive Gram-positive cells adsorbed comparable levels of the bacteriocin and concluded that the specificity of pediocin PA-1 was at least not entirely dependent on the presence of specific receptor sites in sensitive cells, and that pediocin might have a high surface binding capacity responsible for the unlethal binding to insensitive bacteria. Bhunia et al.⁵⁴ reported that the bacteriocin did not bind to the cell surface of Gram-negative bacteria. Although the presence of lipoteichoic acid in the cell wall of Gram-positive bacteria and its absence in Gram-negative bacteria could explain this differential adsorption ability, it did not provide any explanation for the existence of sensitive and insensitive Gram-positive bacteria. These authors⁵⁴ also described how pediocin PA-1-treated sensitive cells lost intracellular K⁺ ions and ultraviolet absorbing material became more permeable to ONPG and in some cases lysed.

The proton motive force (PMF) constitutes a key parameter in the understanding of the mode of action of LAB bacteriocins because it is required for many of the cells energy-dependent metabolic processes. The PMF is the result of the electrochemical gradient of protons across the bacterial cytoplasmic membrane and is composed of the membrane potential ($\Delta\psi$) and the pH gradient (ΔpH).⁷⁴ The development of artificial membrane systems and techniques that allow the separate study of both components of the PMF have enabled the investigation of the effects of different bacteriocins, including pediocin PA-1, on PMF. Christensen and Hutkins¹³ provided the first evidence for the involvement of PMF in the mechanism of action of pediocin PA-1. Pediocin caused a concentration-dependent dissipation of the PMF of *L. monocytogenes* Scott A cells. In addition, the peptide increased the membrane permeability of *Listeria* cells to protons, which agrees with a dissipation of the pH gradient.

These results, together with those obtained with nisin,⁷⁵⁻⁷⁹ lactococcin A⁸⁰, and lactococcin B,⁸¹ led Bruno and Montville⁸² to hypothesize that LAB bacteriocins employ a common mechanism of action based on the dissipation of the PMF of sensitive cells. To obtain further evidence, these authors⁸² also investigated the influence of pediocin PA-1, nisin, lactacin F, and leuconocin S on the PMF of *L. monocytogenes* Scott A cells. During the assay period, the *Listeria* population decreased by 4 orders of magnitude after the addition of pure pediocin (20 $\mu\text{g ml}^{-1}$) to the cultures. Additionally, the residual $\Delta\psi$ (-30 mV) was insufficient for culture viability. Energized cells lost their PMF in a concentration-dependent manner, while the ΔpH component was dissipated by a pediocin concentration lower than that required to eliminate $\Delta\psi$. PMF collapse led to growth inhibition and death because of the low intracellular ATP levels and the inability to carry out active transport of nutrients and to maintain sufficient concentrations of cofactors, such as K^+ and Mg^{2+} . Pediocin PA-1, lactacin F, and leuconocin S acted in an energy-independent manner, in contrast with the energy-dependent mode of action of nisin, a bacteriocin that seems to require a threshold membrane potential for activity.⁸²⁻⁸³

The independent studies of Bruno and Montville⁸² and Chikindas et al.²⁵ indicated that pediocin PA-1 formed voltage-independent pores on the cytoplasmic membranes of target cells, a process that dissipated the transmembrane electrical potential, inhibited amino acid transport and caused an efflux of small ions. Their data also indicated that the pediocin concentration determined the size exclusion limit of the pores since more pediocin was required to release compounds having higher molecular weights (up to 9400). Although pediocin (*in vitro* and at high concentration) worked in the absence of PMF, the possibility that *in vivo* PMF could increase the efficiency of low pediocin concentrations on the target membranes was not excluded. On the basis of these and previous results, the authors proposed a model for the mechanism of action of pediocin PA-1. Initially, pediocin molecules would nonspecifically adhere to the cell surfaces, followed by specific binding to receptor components of the cytoplasmic membrane. Then, pediocin

molecules would insert into the membrane, aggregate and form oligomeric structures, leading to hydrophilic pores through which ions and small molecules would be released from sensitive cells and, ultimately, to cell death. However, in the same study,²⁵ it was found that pediocin binds and inserts in *E. coli* lipid vesicles with a high content of zwitterionic phospholipids but without a protein receptor.

A study on the *in vivo* effect of pediocin PA-1 on *L. monocytogenes* confirmed that, concomitant with cell death, the bacteriocin induced depletion of cytoplasmic ATP and irreversible K^+ and phosphate efflux.⁸⁴ Pediocin PA-1 depleted 90% of cytoplasmic ATP when only 25% phosphate efflux had occurred, which indicated that loss of ATP was due to attempts of the cell to maintain PMF rather than its inability to produce ATP because of phosphate loss. In contrast, nisin causes simultaneous total ATP depletion and phosphate efflux.⁸⁵⁻⁸⁶

Chen et al.²⁸ characterized the physicochemical interactions of pediocin PA-1 with target membranes using two-lipid vesicle models, one based on total *L. monocytogenes* lipids and the second on synthetic phospholipids. The antimicrobial peptide caused a time- and concentration-dependent release of carboxyfluorescein (CF) from the vesicles. The CF efflux rates were higher in acidic than in neutral or alkaline conditions and depended on both pediocin and lipid concentrations. Although pediocin PA-1 was able to permeabilize the membrane of *Listeria* lipid vesicles in the absence of $\Delta\psi$, the presence of a transmembrane potential (inside negative) increased the CF efflux rate by 88%. *In vivo* and *in vitro* energy-enhanced action has been previously reported for bavaricin MN, another class IIa bacteriocin, using the same lipid vesicle model.⁸⁷ Generation of $\Delta\psi$ could have stimulated the formation of more and bigger pores on the target membranes.²⁸ The fact that both lipid vesicle systems were devoid of membrane protein receptors, together with the pediocin concentration-dependent CF leakage, strongly suggested that no protein receptor was required for the recognition and binding of pediocin PA-1 to the membrane of sensitive cells. Instead, the bacteriocin molecules could have recognized specific membrane lipids

and/or established electrostatic interactions with the phospholipid head groups.

As anionic phospholipids are the principal components of *L. monocytogenes* membranes,⁸⁸ Chen et al.²⁸ subsequently characterized the binding of pediocin and pediocin fragments to vesicles of phosphatidylglycerol by using tryptophan fluorescence as a probe. It is possible to differentiate tryptophan residues bound to membranes from those in peptide molecules in an aqueous solution because spectral parameters of its fluorescence emission change with environmental polarity. The results revealed that at least one tryptophan residue of pediocin PA-1 was inserted into the anionic membranes. This work also provided the first evidence for the key role that electrostatic interactions between putative positively charged pediocin patches and the negatively charged phospholipid heads of the membranes play in the initial binding of the bacteriocin to target membranes.

A further study⁸⁹ revealed that affinity of pediocin PA-1 for phospholipid vesicles increases as the content of negatively charged phospholipids is higher. In addition, the relative dissociation constant for the peptide-lipid interaction was higher when the anionic lipid content of the vesicles decreased. This fact reflected the anionic lipid dependency of the initial binding to the membrane and supported the electrostatic interaction model of binding. Similar results have been obtained for the lantibiotics epilancin K7⁸³ and nisin.^{83,90} In addition to the initial unspecific electrostatic interactions, there are important specific interactions between the C-terminal half of pediocin PA-1 and the target cells,²⁴ particularly within the fragment spanning residues 20 to 34³⁰ (see structure-function relationships).

Bennik et al.¹⁸ reported that the exposure of sensitive and insensitive LAB strains to pediocin PA-1 resulted in a similar concentration-dependant dissipation of $\Delta\psi$, but the perturbation of the cytoplasmic membrane caused rapid ATP depletion only in the sensitive cells. These authors suggested that not only membrane fluidity (related to lipid composition), but overall membrane composition would influence the pore-forming activity of bacteriocins, as membrane proteins may affect lipid ordering.

E. Structure-Function Relationships

Despite the fact that class IIa bacteriocins have similar primary structures, their antimicrobial spectra show differences greater than what would be expected from the interaction between the cationic peptides and the membrane lipids.⁵ Therefore, establishment of structure-function relationships constitutes one of the major challenges in bacteriocin research. To facilitate the understanding of this section, Figure 1 shows a schematic representation of the pediocin PA-1 structure-function relationships that are (putatively) known at present.

Several groups have described the loss of pediocin PA-1 antimicrobial activity as a consequence of DTT reduction of its disulfide bonds.^{25,73} DTT-induced reduction had only a moderate effect on curvacin A and sakacin P activities.²⁶ In these bacteriocins only the equivalent of the first pediocin PA-1 disulfide bond (C₉-C₁₄) is present. Thus, the second disulfide bond (C₂₄-C₄₄) in pediocin PA-1 seems to be essential for the biological activity of the peptide. This has been shown for the equivalent C₂₅-C₄₃ disulfide bond in the class IIa bacteriocin divercin V41.⁹¹ The fact that pediocin PA-1 and enterocin A (both with two disulfide bonds) are more active than curvacin A and sakacin P (with only one bond) may be due, at least partly, to the extra disulfide bond.²⁶ These studies suggest that the conserved bond is important but not crucial for antimicrobial activity. Similar findings have been reported with carnobacteriocin B2⁹² and leucocin A,⁹³ but not with mesentericin Y105.⁹⁴ In fact, the activity of a mesentericin variant, which had the C₉ and C₁₄ residues substituted by serine residues, was notably lower than that of the native peptide. Some authors claim that both disulfide bridges are essential for pediocin PA-1 activity because of their supposed role in the maintenance of a conformation compatible with activity.^{83,94}

The primary structure of class IIa bacteriocins may be divided into two functional regions, the well-conserved and hydrophilic N-terminal half and the more heterogeneous and relatively hydrophobic C-terminal half.²⁴ Fimland et al.²⁴ synthesized four hybrid bacteriocins in which the modules corresponding to pediocin PA-1 (Ped), sakacin P (Sak), and curvacin A (Cur) had been

exchanged. The four hybrids (Ped-Sak, Sak-Ped, Cur-Sak, and Sak-Cur) were biologically active. The hybrid bacteriocin had an inhibition spectrum that was similar to that of the bacteriocin from which its C-terminal module was derived and different from the bacteriocin that provided the N-terminal part. Therefore, the C-terminal module of class IIa bacteriocins plays an important role in determining the specificity of target cells. A later report³⁰ indicated that a 15-mer peptide fragment derived from pediocin PA-1 (residues 20 to 34) interfered specifically with pediocin PA-1 target cell interaction, leading to inhibition of the pediocin antimicrobial activity. The fragment also significantly affected enterocin A activity but not that of other closely related bacteriocins (sakacin P, curvacin A, and leucocin A). Among these bacteriocins, pediocin PA-1 and enterocin A have the highest degree of homology in the region spanned by the fragment and, additionally, are the only ones with a cysteine residue in this region. Apparently, inhibition of pediocin PA-1 activity by the fragment was due to specific interference of the fragment with pediocin-target cell interactions and not merely to hydrophobic interactions between these two elements. Recently, site-directed mutagenesis studies of pediocin PA-1 and sakacin P have been performed to elucidate the structural basis for the differences observed in their respective activities and target cell specificities.⁴⁶ By making the primary structure of sakacin P more pediocin PA-1-like, it has been shown that the extra disulfide bond C₂₄-C₄₄ of pediocin PA-1 contributes to both temperature stability and to widening the target cell spectrum. The results also support the previous suggestion^{24,30} that the variable C-terminal part of pediocin-like bacteriocins interacts with the hydrophobic part of the membrane, being an important determinant of target cell specificity.

Chen et al.²⁸ observed that K₁₁ and H₁₂ residues were essential in the bacteriocin binding to phospholipid vesicles. At pH 6, two pediocin fragments, N15 (residues 1 to 15) and N8-15 (residues 8 to 15), bound strongly to lipid vesicles and the binding behavior of N15 was comparable to that of pediocin PA-1. However, the binding ability displayed by fragment N7 (residues 1 to 7), which do not contain the positively charged resi-

dues, was only weak. In addition, no binding was observed at the same pH value using the mutant N^m8-15, in which K₁₁ and H₁₂ had been replaced by uncharged residues (I₁₁ and L₁₂, respectively). Binding of the fragments containing this putative positive patch decreased by adjusting the pH to 8, probably because of the deprotonation of the histidine residue.

The finding that an in-frame fusion between the functional mature domain of pediocin PA-1 and the C-terminus of the secretory protein maltose-binding protein (MBP) retained antimicrobial activity⁹⁶ suggests that the bacteriocin N-terminal region does not span the phospholipid bilayers of the target cells. The same study revealed that the class IIa consensus sequence is essential for pediocin PA-1 activity because its deletion resulted in loss of the activity.

Miller et al.⁹⁷ generated a collection of 18 pediocin mutants, 17 of which were obtained by random PCR mutagenesis of the pediocin PA-1 structural gene. They were produced and secreted as MBP-fusion proteins. Eight mutants (N5K, C9R, C14S, C14Y, C24S, G37E, G37R, and C44W) were completely inactive, while nine (K1N, W18R, I26T, M31T, A34D, N41K, H24L, K43N, and K43E) retained some activity, ranging from <1 to 60%. However, the activity of the remaining mutant (K11E) was around 2.8-fold higher than that of the MBP-pediocin PA-1 chimeric protein. The results showed that the four cysteine residues were required for activity. The disulfide bond may be essential to maintain the conformation of the sequence G₁₀-K₁₁-H₁₂-S₁₃ that constitutes the apex of the β -hairpin previously proposed by Chen et al.²⁷ and that exhibited weak homology to several known types of consensus β turns. Among the four lysine and three histidine residues of pediocin PA-1, three residues (K₁, H₄₂, and K₄₃) seemed to be particularly important for activity.⁹⁶ The substitution K1N resulted in an almost complete inactivation of bacteriocin activity, while the substitutions H42L, K43N, and K43 reduced its activity by 40 to 80%. Therefore, K₁ may play an essential role in membrane binding while that of H₄₂ and K₄₃ would be secondary. These results⁹⁷ show that protein engineering of class IIa bacteriocins could be a feasible way to improve their activity, stability, and/or solubility.

Miller et al.⁹⁷ submitted the pediocin C-terminal half to hydrophobicity analysis in order to locate apolar sequences that could participate in membrane binding. In this region, the stretch comprising residues I₂₅ to G₃₇ had enough hydrophobicity to allow its location inside a phospholipid bilayer if simultaneous membrane insertion of two or more molecules would occur, something that probably does occur during the formation of the poration complex.

It has been suggested that the C-terminal module of pediocin PA-1 would become amphiphilic, and therefore would permit the formation of a poration complex if it adopted a transmembrane α -helical secondary structure.²⁴ However, adoption of such a structure seems incompatible with the disulfide bond C₂₄-C₄₄ formed by residues located at the beginning and end of such an α -helix.²⁶ The effect of this disulfide bridge in the structure of the C-terminal region will have to be determined before drawing any conclusion on the role of amphipathicity, if any, in the formation of the poration complex.⁹⁷

IV. BIOSYNTHESIS

A. Location of the Genetic Determinants

The genetic determinants for the biosynthesis of pediocin PA-1 are plasmid encoded in all producing strains isolated to date.^{8,11,15,17-19,23,34,98,99} In several strains, the sizes, organization, and restriction profiles of the various pediocin-encoding plasmids are similar.^{17,100} It has been shown that the plasmids responsible for production in *P. acidilactici* H can be transferred intragenetically by conjugation.³⁴

B. Organization of the Pediocin PA-1 Operon

Pediocin PA-1 biosynthesis involves a DNA fragment of approximately 3.5 kb, comprising the four genes *pedA*, *pedB*, *pedC*, and *pedD*.²² Each gene is preceded by a ribosome binding site (RBS), starts with the AUG start codon (except *pedB*, which starts with a UUG codon), and finishes

with a UAG stop codon²² (Figure 2). The four genes are organized in a single operon, governed by a promoter located directly upstream of *pedA*. The sequences of its -35 (TTGACA) and -10 (TAGAAT) regions, separated by 18 bp, are in close agreement with the consensus sequences of constitutive promoters of Gram-positive bacteria.^{22,101} Two transcripts are produced from the pediocin PA-1 operon. The most abundant messenger has a size of approximately 1.2 kb and covers *pedABC*, while the second transcript has a size of 3.5 kb and corresponds to the *pedABCD* genes.⁵⁵ There are *rho*-independent transcriptional terminators directly downstream of the *pedC* and *pedD* genes^{55,102} (Figure 2).

The production of some class II bacteriocins has been reported to be a quorum sensing phenomenon.¹⁰³ The process is transcriptionally regulated through a signal transduction system integrating an induction factor (peptide pheromone), a histidine protein kinase and a response regulator. The induction factor is a bacteriocin-like peptide with a double-glycine leader but without bacteriocin activity.⁴ There is no evidence for the existence of a similar system for the activation of transcription of the pediocin PA-1 genes.

C. The *pedABCD* Genes and Their Products

The pediocin PA-1 structural gene (*pedA*) encodes a 62 amino acid pediocin precursor called prepediocin PA-1. The 18 N-terminal residues of prepediocin constitute the leader sequence, which is removed concomitantly with secretion, resulting in mature pediocin PA-1, a peptide of 44 amino acids. The pediocin leader belongs to the group of the "double-glycine" leaders, which is found in most nonlantibiotic and some lantibiotic LAB bacteriocins and also in colicin V from *E. coli*. These leaders share the consensus sequence L₁₂S₁₁XXE₈L₇XXI₄XG₂G₁ with the two conserved glycine residues at positions -1 and -2 constituting a common processing site, a fact reflected in the name of the group.^{3,104,105} Prepeditocin PA-1 is also biologically active,⁵⁵ approximately 80% as active as the mature bacteriocin.¹⁰⁶

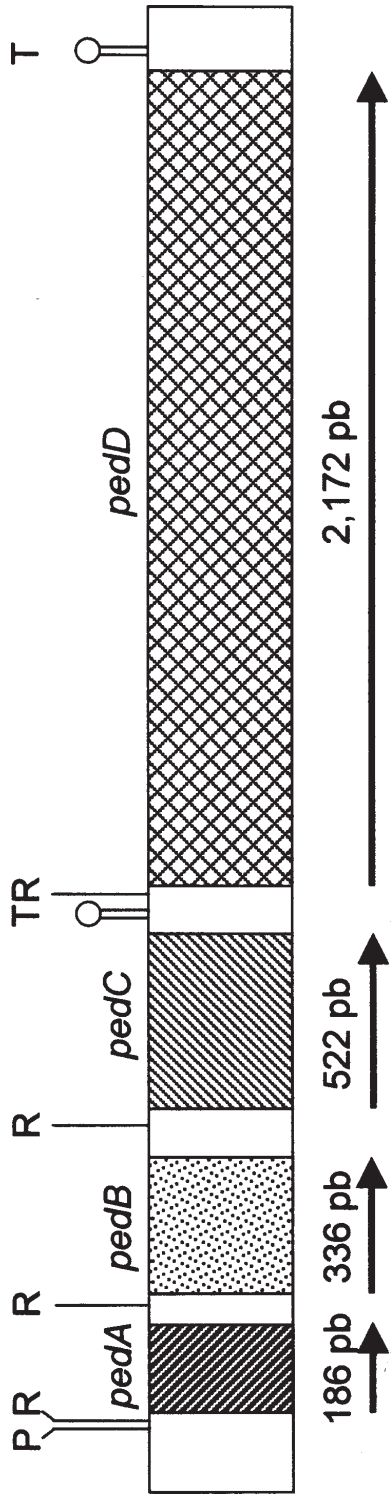

FIGURE 2. Schematic representation of the pediocin PA-1 operon. P, promoter; R, ribosome binding site; T, transcriptional terminator.

Marugg et al.²² suggested that the 112 amino acid protein encoded by *pedB* could be involved in immunity of the producing cells, because mutational inactivation of this gene did not affect pediocin PA-1 production in *E. coli*, a microorganism naturally insensitive to this bacteriocin. Later, this hypothesis was confirmed as pediocin PA-1 was not active against a previously sensitive *P. pentosaceus* strain that had been transformed with a plasmid carrying the *pedB* gene.⁵⁵ In fact, the level of insensitivity of the resulting strain was even higher than that of the parental producer, probably because of the higher copy number of the plasmid encoding *pedB* in the transformant and/or because *pedB* was cloned under the control of P32, a strong lactococcal promoter.

Recently, several immunity proteins belonging to pediocin-like bacteriocins were cloned behind P32.¹⁰⁷ Introduction of the different pediocin-like immunity genes into a highly bacteriocin-sensitive *Lb. sakei* strain resulted in a selective immunity against the respective pediocin-like bacteriocins tested. In general, low cross-immunity was observed; however, PedB and the immunity protein for sakacin P displayed complete cross-immunity despite the degree of sequence similarity between these two immunity proteins is lower than that observed between, for instance, PedB and the enterocin A immunity protein.¹⁰⁷

The *pedC* gene encodes a 174 amino acid protein (PedC), which is essential for pediocin secretion in pediococci and *E. coli*,⁵⁵ and belongs to the group of so-called “*accessory proteins*” required for secretion processes involving ATP-binding cassettes (ABC) transporters. Accessory proteins are also called “*membrane fusion proteins*” (MFP) because it has been postulated that they may connect the inner and outer membranes of Gram-negative bacteria to facilitate the passage of substrates.¹⁰⁸ The PedC structure is similar to those of HlyD, a protein required for secretion of the *E. coli* hemolysin A,¹⁰⁹ and LcnD, a protein involved in lactococin A transport.¹¹⁰

Finally, *pedD* encodes PedD, a 724 amino acid ABC transporter dedicated to pediocin secretion through the membrane of the producing cells. Inactivation of this gene leads to total loss of antimicrobial activity because of lack of secre-

tion.²² The PedD sequence displays a high degree of homology with sequences of many others ABC transporters.¹⁰⁵

D. Secretion and Maturation of Pediocin PA-1

The secretion and maturation processes of pediocin PA-1 depend on the membrane proteins PedC and PedD, which together form a type I secretion system.¹¹¹ In this *sec*-independent system, the substrate is directly secreted from the cytoplasm of the cell to the extracellular environment. As type I secretion systems are specific for a protein or family of closely related proteins, they are often called “*dedicated*” transport systems.^{112,113}

A typical ABC transporter probably functions as an homodimer, each part consisting of a hydrophobic integral membrane domain and two ATP-binding domains, which can be fused in a multidomain protein.¹¹³ All transporters dedicated to “double glycine” prebacteriocin secretion have an N-terminal cytoplasmic extension that forms the proteolytic domain responsible for removal of the leader peptide. In the N-terminal part of these bacteriocins transporters there are two conserved motifs, the cysteine motif (QX₄D/ECX₂AX₃MX₄Y/FGX₄I/L) and the histidine motif (HY/FY/VVX₁₀I/LXDP).^{4,105} Based on the work of Havarstein et al.,¹⁰⁵ with lactococin G, the following hypothesis for the export of pediocin PA-1 can be made.⁴ The proteolytic domain of PedD binds to prepediocin PA-1. Then, hydrolysis of ATP induces conformational changes in PedD leading to an integrated process in which removal of the pediocin leader concomitantly occurs with pediocin translocation across the cytoplasmic membrane. In fact, expression of only the N-terminal 172 amino acids of PedD in *E. coli* cells producing prepediocin showed that this domain was enough and essential for prepediocin processing.⁵⁵ Under these circumstances, mature pediocin could only be found intracellularly, which suggests that the cleavage process can be uncoupled from secretion.

Apart from the extended N-terminal domain responsible for the processing of the prebacteriocin into the mature form, the ABC transporters dedi-

cated to double glycine leader bacteriocins probably also differ from the earlier described “classical” ABC transporter proteins in their membrane topology. It has been reported that the lactococcin A-dedicated ABC transporter (LcnC) has four transmembrane segments (TMSs) instead of the six typically present in the classical ones.¹¹³

The accessory protein (PedC) has a membrane topology similar to LcnD, the lactococcin A accessory protein. Both are bitopic proteins with a short N-terminal cytoplasmic part, a transmembrane segment and a large extracellular C-terminal part.¹¹³ Venema et al.⁵⁵ speculated that PedC may be involved in channel formation between the cytoplasmic membrane and the cell wall of pediocin-producing cells. A similar role has been proposed for LcnD.¹¹³ Recently, LcnD was shown to be present in two forms: a 52-kDa full-length form, totally contained in the cytoplasmic membrane, and a smaller form (LcnD*, 38 kDa) that is present mainly in the cytoplasm with a small amount localized in the membrane.¹¹⁴ LcnC and LcnD are organized in a membrane-associated complex in which LcnD, probably present as a dimer, is able to interact with LcnD* and LcnC.¹¹⁴ In addition, LcnC cross-links with a small peptide that could be the bacteriocin lactococcin A.¹¹⁴

E. Heterologous Expression of *ped* Genes

Heterologous expression systems are usually employed to elucidate the function of recombinant proteins or peptides or to achieve levels of production higher than those of the native sources. They are also useful to produce a protein or a peptide by specific species, or strains, that are better adapted than the native producer to the environment where application of the proteinaceous compound is desired.

Escherichia coli has long been the primary prokaryotic host for cloning genes and expressing recombinant proteins because it is well characterized, many of its biological processes are understood and there are many genetic tools readily available for its manipulation.¹¹⁵ Regarding pediocin PA-1, transformation of *E. coli* strains with a plasmid containing the pediocin operon

resulted in correct expression of the pediocin genes since the transformants produced zones of inhibition on the indicator lawn.²² As bacteriocin activity was also observed in cell-free supernatants, the authors concluded that pediocin was, most probably, secreted by the cells. *E. coli* mutants with a mutated *pedD* gene did not secrete pediocin, which confirmed the role of PedD in pediocin transport.

In the absence of *pedC* and *pedD*, mature pediocin PA-1 can be secreted in an active form when fused to the MBP C-terminus and therefore coupled to the *E. coli* *sec* machinery.⁹⁶ The chimeric protein was released into the culture medium because it was expressed in a leaky *E. coli* host in which the gene encoding the outer membrane murein lipoprotein had been disrupted.

Although there is a wealth of tools for exploiting *E. coli* for heterologous gene expression, other bacteria can offer advantages either for cytoplasmic production, secretion, or surface display.¹¹⁶ Some LAB species, such as *L. lactis* are proving to be very versatile, and continuing basic research on gene expression in these organisms will increase their utility as alternative hosts for heterologous gene expression. In addition, many LAB species or strains are food-grade organisms, making them potentially useful for the heterologous (*in situ*) production of commercially important proteins or peptides.¹¹⁵

An attractive possibility for heterologous production of pediocin PA-1 is to exploit the significant amino acid homologies in both the leader peptides and dedicated transporters of most class II bacteriocins, some lantibiotics, and also colicin V produced by *E. coli*.^{55,104,105} Allison et al.¹¹⁷ showed that both peptides of the two-component lactacin F complex can use the bacteriocin secretion machinery of *Carnobacterium piscicola* LV17, a strain that produces carnobacteriocins A, BM1, and B2.¹¹⁸ The fact that the leaders of these carnobacteriocins and both lactacin F peptides share the highest degree of homology among class II bacteriocins may have facilitated the secretion of the lactacin F peptides in this heterologous host. van Belkum et al.¹¹⁹ recently demonstrated the flexibility of the translocation apparatus by exchanging the leader peptides of different class II bacteriocins. Gene fusions were generated in

which sequences encoding the leader peptides of leucocin A, lactococcin A, and colicin V were fused to divergicin A, a bacteriocin that is secreted through the *sec* pathway.¹²⁰ The different leader peptides were able to direct the secretion of divergicin in *Leuconostoc gelidum*, *L. lactis*, and *E. coli*, respectively (i.e., the homologous hosts). Furthermore, certain leader-translocator combinations led to heterologous production of divergicin. Colicin V was also secreted from *L. lactis* when it was fused to the leucocin A leader and the lactococcin A secretion machinery was used. However, in some cases, the leader peptides were unable to direct divergicin secretion, suggesting that the various components of the translocation apparatus of class II bacteriocins are not universally interchangeable. It may be that the hydrophobicity of the heterologous peptide plays an important role in the secretion process.¹¹⁹ Although the system LcnC/LcnD can secrete a great variety of bacteriocins that differ quite drastically (like lactococcins A, B, and M/N),¹¹¹ its inability to direct secretion of leucocin A in *L. lactis* has also been reported.¹²¹

Pediocin PA-1 is a bacteriocin with a broad inhibitory spectrum and is particularly effective in preventing the growth of *L. monocytogenes*, a major concern in the dairy industry because it can grow in a variety of dairy products at low temperature and pH. However, with the exception of *Lb. plantarum* WHE 92,¹⁷ all pediocin PA-1-producing bacteria so far isolated are pediococci, organisms usually associated with vegetable and meat substrates but poorly adapted for growing in milk and dairy products. Therefore, the production of pediocin PA-1 in strains of dairy origin is highly desirable.

The four *ped* genes were cloned into a lactococcal vector and introduced into *L. lactis* IL1403, a pediocin PA-1-resistant, plasmid-free strain that does not produce bacteriocin but harbors chromosomal genes analogous to those encoding the lactococcin A secretion apparatus (*lcnC* and *lcnD*).^{55,122,123} Secretion of pediocin PA-1, directed by its own leader sequence, was detected only when the *ped* operon was under the control of the strong lactococcal promoter P32. Even under these conditions, the pediocin yield was less than 1% of the production level by the *Pediococcus*

parental strain. It was possible to increase the relative pediocin PA-1 production level to approximately 50% in *L. lactis* LL108, a derivative of *L. lactis* MG1363, by increasing the copy number of the plasmid-encoded *ped* operon. In the same work,¹²² a recombinant *P. acidilactici* strain was obtained that produced and secreted both active pediocin PA-1 (an amount similar to that of the parental pediococcal strain) and lactococcin A (twofold lower than that of the parental lactococcal strain).

Pediocin PA-1 and lactococcin A are both class II bacteriocins and, hence, likely candidates for expression and secretion in *L. lactis* via heterologous translocators.³⁸ A hybrid gene specifying an in-frame fusion of the lactococcin A leader and pediocin PA-1³⁸ was introduced in *L. lactis* IL1403 (LcnC⁺, LcnD⁺). The *L. lactis* IL1403 derivative produced extracellular pediocin activity, but the production level was approximately 25% of that of the parental pediococcus strain. Significant reductions in the yield of lactococcin A expressed in IL1403 have been described previously.^{36,80} These reductions may be attributed to the low copy number of the chromosomal *lcnC'D'* genes¹²³ and/or to differences in the lactococcin A translocation apparatus,^{119,123} resulting in less efficient secretion.

Enhanced heterologous production of pediocin PA-1 was obtained by introducing the *lcnC* and *lcnD* genes into the lactococcin A leader-pediocin PA-1 expression system previously developed.³⁹ When *lcnC* and *lcnD* were present on the same plasmid (a pSH71 derivative, 50 to 60 copies per cell¹²⁴) as the hybrid gene, one of the resulting *L. lactis* IL1403 derivatives attained pediocin PA-1 levels similar to that of the natural producer *P. acidilactici* 347. The yield of LcnC/D-mediated translocation of pediocin PA-1 was strongly influenced by the plasmid dosage and by the particular lactococcal strain employed as a production host. It has also been demonstrated that heterologous production of other class II bacteriocins can increase at least 10-fold when the dedicated *lcnC* and *lcnD* genes are included in equivalent lactococcal expression systems.^{80,123} In the same study,³⁹ *L. lactis* strains with the ability to express and secrete nisin A together with pediocin PA-1 were also constructed, which represents a first

step in the construction of LAB strains that coproduce two or more well-characterized wide-spectrum bacteriocins. Recently, low-level coproduction of the nonsynergistic class IIa bacteriocins pediocin PA-1 and enterocin A in *L. lactis* IL1403¹²⁵ and production of a variable amount of pediocin PA-1 in *E. coli*, *L. lactis*, *Streptococcus thermophilus*, and *Enterococcus faecalis* have also been achieved.¹²⁶ The cells were transformed with shuttle vectors containing the four genes of the *ped* operon (without its own promoter) behind the *S. thermophilus* promoter ST_{P2201} .

Yeast, especially *Saccharomyces cerevisiae* and *Pichia pastoris*, are major hosts employed in the expression of heterologous proteins of high quality in the biopharmaceutical, industrial, and academic environments because they combine well-known techniques for the molecular manipulation of prokaryotes with the authenticity of eukaryotic systems.¹²⁷ Frequently, excessive amounts of sulfur dioxide and other chemical preservatives are used to prevent growth of undesirable bacteria during the making of wine, beer, and other beverages. This practice affects the quality of the end-products and raises increasing consumer concerns. Schoeman et al.¹²⁸ investigated the feasibility of controlling spoilage bacteria during yeast-based fermentations by expressing pediocin PA-1 in *S. cerevisiae*. To achieve this objective, the *pedA* gene was inserted into a yeast expression/secretion cassette in which expression of *pedA* was under the control of the yeast alcohol dehydrogenase I gene (*ADHI*) promoter and terminator, and the secretion of the bacteriocin was directed by the secretion signal of the yeast mating pheromone α -factor (*MF α 1₅*). The construct was introduced as a multicopy plasmid in *S. cerevisiae*. Northern blot analysis confirmed that *pedA* was efficiently transcribed, while biologically active bacteriocin was detected in a bioassay. However, the heterologous peptide was present in relatively low levels in the yeast culture supernatant because most of the bacteriocin molecules were attached to the yeast cells. Production of extracellular pediocin PA-1 by recombinant yeast strains may be optimized by enhancing *pedA* gene expression as well as by increasing the secretability of the recombinant bacteriocin. It

has been reported that *S. cerevisiae* is often limited as an expression system by low yields, while other yeast species, such as *P. pastoris* or *Hansenula polymorpha*, retain all the advantages of *S. cerevisiae* and provide a reliable means of achieving greatly elevated yields.¹²⁹⁻¹³¹

The development of systems for heterologous production of pediocin PA-1 and other bacteriocins, either using ABC-transporters or *sec*-dependent secretion systems, may contribute to overcome problems that bacteriocin-producing starter cultures often face in food processes, such as poor adaptability, low production, or genetic instability. In addition, these heterologous systems could be used for production of hybrid bacteriocins or pediocin-like bacteriocins with improved properties obtained by protein engineering. Overexpression of the *ped* genes by use of food-grade inducible systems, like those based on the *PnisA* promoter¹³²⁻¹³⁵ or the salt-inducible *Pgad* promoter^{136,137} could be another interesting approach. Recently, enhanced secretion of pediocin PA-1 was achieved in a *L. lactis* strain following induced expression of *pedC* and *pedD* behind the *Pgad* promoter.¹³⁸

F. Factors Affecting Pediocin PA-1 Biosynthesis

The amount of pediocin PA-1 produced is very strain-dependent, although the variability seems to be less than that observed, for instance, among different nisin- or leucocin Lcm1-producing strains.¹³⁹ Under the same conditions, *P. acidilactici* H produced more pediocin than strains E, F, and M,¹⁰⁰ which was attributed to the higher growth rate of strain H and/or to the higher genetic stability of the plasmid on which the pediocin operon is located in that strain. The level of pediocin PA-1 produced by *Lb. plantarum* WHE 92 was higher than that of *P. acidilactici* H under optimum culture conditions, although production *per* cell was not reported.¹⁷ Recently, specific antibodies were used to determine the concentrations of pediocin PA-1 in the supernatants of five independently isolated *P. acidilactici* strains.⁴¹ While four of the strains produced similar amounts (ranging from 1946 to 2200 ng ml⁻¹), the bacteriocin con-

centration in the supernatants of the remaining strain was significantly lower (12 ng ml⁻¹).

Pediocin PA-1 production is higher when the producing pediococci are grown at 30 to 37°C⁵⁰ in media that allow the development of a high cell mass and a high acidity, such as MRS or TGE.^{50,139,140} The addition to TGE broth of supplements (tryptone, glucose, yeast extract) or complements (niacinamide, panthotenic acid, biotin) that stimulate cellular proliferation notably increased pediocin production, while production decreased by incorporating buffering compounds.¹³⁹

A clear reduction in the quantity of pediocin produced either by *P. acidilactici* strains or *Lb. plantarum* WHE 92 was observed when the final pH of the medium exceeded 4.0.^{17,141} While bacteriocin production by *P. acidilactici* H was negligible when the pH of the medium was 5 and ceased at pH 5.5, even at high cell densities,^{17,140} the activity of culture extracts from *Lb. plantarum* WHE 92 remained constant independently of the final pH value of the culture broth between pH 4.0 and 6.0 at pH and decreased only at pH 6.5.¹⁷ A later study confirmed that the amount of pediocin PA-1 produced by *Lb. plantarum* WHE 92 at the end of the exponential growth phase is independent of the pH of the culture medium between pH 4.0 and 6.0.¹⁴¹

It has been suggested that processing of prepediocin to active pediocin by pediococci takes place efficiently only if the pH of the medium is less than or equal to 5.0.^{139,142} Although this would explain why pediocin production by *P. acidilactici* decreases when the final pH of the culture is higher than 5, it is not clear why that of *Lb. plantarum* WHE 92 is not reduced up to pH 6.0.¹⁷

Culture pH may have played an important role in the yield of pediocin PA-1 by the heterologous lactococcal host *L. lactis* FI9043, because larger inhibition zones were generated from supernatants of cultures grown in MRS broth (final pH 4.6) than from those in GM17 broth (final pH 5.3).³⁸

The highest pediocin yields can be obtained by determining the optimal conditions for pediocin production during pH- and temperature-controlled batch cultures in a fermentor.^{141,143} Under such conditions, batch cultures of *P. acidilactici* UL5-T5 at 37°C and pH 5.5 yielded approximately 190 mg l⁻¹ of pediocin.

V. TOXICITY

Pediocin-producing strains are found in a variety of natural foodstuffs, such as meat products,^{8,10,19,34} dairy products,¹⁷ and vegetables.¹⁸ Therefore, they (and most probably pediocin too) have been ingested by human consumers for centuries without apparent adverse effects, which is a first indication of low toxicity of this bacteriocin toward eukaryotic cells. Additionally, treatment of mouse myeloma cell cultures with pediocin PA-1 did not affect cellular viability or morphology,⁵⁰ and no detrimental effects have been observed after subcutaneous, intradermic, intravenous, or intraperitoneal administration of this bacteriocin (or fragments thereof) to mice and rabbits^{14,40,41,144-146} or after prolonged ingestion by humans of meat products made with the pediocin-producing strain *P. acidilactici* H.¹⁴⁷ Finally, the intestinal microflora is probably unaffected by pediocin PA-1 because of its inactivation by the proteolytic enzymes of the digestive tract.

VI. IMMUNOLOGICAL PROPERTIES

In general, generation of antibodies against bacteriocins may provide sensitive and specific tools for the detection of producing strains and for the quantification of the peptides in culture media and food extracts by immunochemical assays.^{40,41,43,145,146,148-150} Moreover, antibodies may be used in single-step purification methods based on immunoaffinity strategies.⁴⁴ Although highly specific immunochemistry-based methods have been developed and routinely used as analytical tools in many research areas, their impact in the bacteriocin research field has been marginal.¹⁴⁹ Thus, identification and detection of bacteriocinogenic LAB and bacteriocins has relied on the use of sensitive but unspecific bioassay-based tests.

The two main difficulties encountered in raising antibodies against bacteriocins are the lack of commercially available purified bacteriocins and the need to couple them to proper carrier proteins because of their low molecular masses (which make them poorly immunogenic or nonimmunogenic). In addition, some characteristics of class II LAB bacteriocins such as hydrophobicity or the pres-

ence of intrachain disulfide bonds may interfere with the development of sensitive immunoassays.

Bhunia et al.¹⁴⁴ evaluated the immunogenic properties of partially purified pediocin by immunizing mice and a rabbit and found that it was unable to illicit an antibody response, even after conjugation of the peptide to bovine serum albumin. Polyclonal and monoclonal antibodies against pediocin were developed by immunizing mice for 12 weeks with pediocin conjugated to a polyacrylamide matrix.¹⁴⁸ Among 230 hybridoma clones generated after two fusions, two were found to produce antibodies that in Western immunoblots recognized this bacteriocin (detection limit: 10 $\mu\text{g ml}^{-1}$) but did not react with sakacin A, leuconocin LCM1, nisin and pediocin A. Immunization of mice with crude precipitates of pediocin PA-1 or with pediocin bound to heat-killed *Lactobacillus plantarum* cells failed to produce antibodies against the bacteriocin. In colony immunoblot assays, the monoclonal antibodies were used to differentiate Ped⁺ and Ped⁻ variants of *P. acidilactici* RS2. Although monoclonal antibodies could be very useful in developing quantitative assays for pediocin production, to date no new developments have been reported from this line of research.

Development of successful polyclonal and monoclonal antibodies and immunoassay formats have enabled the sensitive and specific detection and quantification of nisin.^{43,44,149,150} Commercial preparations of pure pediocin PA-1, unlike nisin, are not available, and current pediocin PA-1 purification protocols do not allow purification of the large quantities of peptide needed to carry out cost-efficient immunization protocols. The use of whole bacteriocins, either alone or conjugated to carrier proteins may, if successful, lead to the generation of unspecific polyclonal antibodies due to cross-reactivity with consensus amino acid sequences found in other bacteriocins, and especially among class IIa LAB bacteriocins.^{4,26,151} Short peptide fragments of proteins can be used to generate antibodies that frequently recognize the folded protein from which the peptide sequence was derived,¹⁵² a fact that explains why antipeptide antibodies have become important tools in many research fields.^{153,154} Chemically synthesized fragments selected from the amino acid sequence of

pediocin PA-1 could, thus, potentially facilitate obtaining antibodies of predetermined specificity for the recognition of the native peptide molecule.¹⁴⁵

Recently, such polyclonal antibodies against pediocin PA-1 have been generated by immunization of rabbits with a chemically synthesized C-terminal fragment (PH2, residues 34 to 44) conjugated to the carrier protein keyhole limpet hemocyanin (KLH).⁴⁰ The limits of detection of pediocin PA-1 in MRS medium using these antibodies were approximately 2.5, 1, 0.025 and <0.025 $\mu\text{g ml}^{-1}$ by immunodotting, noncompetitive indirect ELISA (NCI-ELISA), competitive indirect ELISA (CI-ELISA) and competitive direct ELISA (CD-ELISA), respectively. All immunoassays and the slot-dot assay detected the bacteriocin in the supernatant of the producer *P. acidilactici* 347. The antibodies did not cross-react with other bacteriocins, including other members of class IIa LAB bacteriocins, and were very useful in demonstrating heterologous production of pediocin PA-1 in *L. lactis*.^{38,125}

Pediocin PA-1-specific rabbit polyclonal antibodies have also been generated with a synthetic 1 to 9-N-terminal fragment (PH1) conjugated to the same carrier protein.⁴¹ In this case, the limits of detection of pediocin PA-1 in MRS medium were approximately 5, 0.5, 0.01, and <0.01 $\mu\text{g ml}^{-1}$ by protein slot-blotting, NCI-ELISA, Western blotting, and CI-ELISA, respectively. The amount of free pediocin required for 50% binding inhibition was 0.1 $\mu\text{g ml}^{-1}$ as determined by CI-ELISA. In addition, results obtained with the same assay clearly indicated that when pediocin, instead of ovalbumin-conjugated pediocin, was used as solid-phase antigen, the assay was notably better. In contrast, pediocin did not efficiently compete with the conjugate pediocin-horseradish peroxidase for binding to antibody-coated microtiter plate wells in CD-ELISA, confirming the results of previous work¹⁴⁵ and highlighting the importance of the selection of proper immunoassays for bacteriocin detection. The PH1-KLH polyclonal antibodies detected the peptide in the supernatants of five pediocin-producing *P. acidilactici* strains.⁴¹ However, it did not or only slightly reacted with supernatants of LAB strains producing enterocin A, enterocin P, sakacin P, or

sakacin A, bacteriocins that contain the longer (KYYGNGVxC) or shorter (YGNGVxC) consensus amino acid sequence present in pediocin PA-1. This result is not surprising because it has been shown that, within a peptide fragment, changes in a single amino acid residue can drastically affect protein recognition.¹⁵⁵

The conjugate PH2-KLH has also been used to immunize mice in order to obtain a source of pediocin PA-1 monoclonal antibodies. However, among the hybridomas generated after three fusions, none produced antibodies.¹⁴⁶

VII. FOOD APPLICATIONS

Although frequently *in vitro* studies have shown the high antimicrobial activity of pediocin PA-1 against sensitive bacteria, particularly *L. monocytogenes* strains, most food applications of this bacteriocin have resulted in relatively modest reductions of 1 to 3 log cycles in the populations of potential foodborne pathogens.⁴⁵ Therefore, deductions obtained from *in vitro* challenges should not be extrapolated to predict pediocin efficacy in a food matrix.¹⁵⁶ Factors that may lead to a reduction of pediocin activity in foods include those affecting the pediocin-producing strain (such as inadequate environment, spontaneous loss of the bacteriocin-producing ability, phage infection, or antagonism by other microorganisms) and those affecting the bacteriocin action (such as emergence of bacterial resistance, bacteriocin binding to food components, or poor solubility or stability in the food substrate).^{45,156,157}

Although the levels of bacterial population reduction achieved by pediocin PA-1 in foods may preclude its consideration as a primary preservation method, this bacteriocin and/or the producing strains could be very useful as an additional safety factor contributing to the “hurdle” or “barrier” approach for preservation of foods.^{7,45} In this kind of food preservation systems, the combined effects of intrinsic (e.g., pH, heat treatment, salt, sugar, chemical additives) and extrinsic (e.g., storage conditions) inhibitory barriers work synergistically to extend storage life and ensure the microbiological safety of foods.¹⁵⁸ Currently, the incorporation of pediocin or other

LAB bacteriocins to this approach is attractive because the range of minimally processed foods available in the marketplace is rapidly increasing.⁷

A. Meat and Meat Products

Kalchayanand¹⁵⁹ studied the action of pediocin PA-1 (1,400 AU ml⁻¹) added to beef meat inoculated with food-spoilage strains of *Clostridium laramiae*, *Lactobacillus* spp., and *Leuconostoc*. Subsequently, the meat samples were vacuum-packaged and stored in refrigeration. Under these conditions, the treated samples remained unaltered after storage for 12 weeks and the population levels reached by the spoilage bacteria were significantly lower in the samples containing the bacteriocin than in the respective control samples. Simultaneously, another study¹⁶⁰ evaluated the ability of pediocin PA-1 (500 to 5000 AU ml⁻¹) to prevent the adhesion of *L. monocytogenes* to irradiated beef meat and to decontaminate the meat inoculated with 10² to 10⁴ cfu g⁻¹. Both strategies reduced the populations of *L. monocytogenes* between 1.2 and 2 log cycles, and the residual bacteriocin activity was detected on the meat surface for at least 28 days at 5°C.

Berry et al.¹⁶¹ employed the pediocin-producing strain *P. acidilactici* JD1-23 as starter culture for the elaboration of meat products and found that it provided a 2-log reduction in added *L. monocytogenes* (10⁶ cfu g⁻¹) during summer sausage production, which are results similar to those obtained by Foegeding et al.¹⁶² However, after storage for 2 weeks, 10% of the sausages were *Listeria*-positive, a result contributing to the current concern for the potential presence of this foodborne pathogen in ready-to-eat foods, even if the initial levels are much lower in most of the cases. Later, Berry et al.¹⁶³ showed that coinoculation of *P. acidilactici* JD1-23 and *L. monocytogenes* in frankfurters, followed by vacuum packaging and storage at 4°C, prevented the growth of the pathogen for at least 60 days.

Yousef et al.¹⁶⁴ compared the ability of pediocin PA-1 and a pediocin-producer to control the growth of three *L. monocytogenes* strains in wiener sausage exudates and showed that both

approaches significantly decreased their growth under refrigerated (4°C) and abusive (25°C) temperature conditions. Although the decrease in *Listeria* populations was faster when adding the bacteriocin, lower final levels were achieved using the producing strain. Similar findings were obtained by Degnan et al.¹⁶⁵ Surface inoculation of wiener sausages with *L. monocytogenes* and a pediocin-producing *Pediococcus* strain, packaging and storage at 4 and 25°C revealed that, in this case, the producer was unable to grow or produce the bacteriocin at 4°C, while reductions of up to 3.4 logs in *Listeria* levels were observed at 25°C.¹²

Motlagh et al.⁶² examined the effectiveness of pediocin PA-1 in reducing the population of three *Listeria* strains in sterile ground beef, sausage mix, Cottage cheese, ice cream, and reconstituted dry milk and observed that the bacteriocin action was immediate and was not affected by the food system tested. In addition, these authors showed that the activity was concentration and strain dependent. For example, 1350 AU ml⁻¹ of pediocin reduced the population of *L. monocytogenes* ScottA, *L. monocytogenes* Ohio2, and *L. ivanovii* ATCC 19119 in 1, 3, and 7 log cycles, respectively. A listericidal effect (approximately 7 log cycles) has been observed in slurries prepared from vacuum-packaged ready-to-eat turkey breast meat and challenged with *L. monocytogenes* in the presence of diacetate and pediocin.¹⁶⁶ The increased antilisterial activity in slurries with diacetate in combination with the bacteriocin were due to synergistic effects. The listericidal activity of pediocin PA-1 has also been evaluated in slurries of beef muscle tissue, beef tallow, nonfat dry milk, and butterfat inoculated with a mixture of two *L. monocytogenes* strains.¹⁶⁷ For all slurries tested, the greatest decrease in *Listeria* counts (1.2 to 1.8 log cycles) occurred within 1.5 min of pediocin addition. In the same study, pediocin was also encapsulated within phosphatidyl-choline-based liposomes before addition to the slurries or unencapsulated in slurries containing the emulsifier Tween 80. In both cases, the pediocin activity recovered from the slurries was notably higher than that obtained after adding free pediocin PA-1. Cold storage of *L. monocytogenes*-inoculated pork in the presence of pediocin resulted in a 2 log reduction after 24 h when compared with

untreated controls, regardless of whether the samples were stored under air, vacuum, or a modified atmosphere.¹⁶⁸

Goff et al.⁶⁴ bound pediocin PA-1 to heat-killed producer cells by adjusting the pH of the medium to 6.0 and the preparation was added to irradiation-sterilized raw chicken breast meat. The results suggested that pediocin-treated raw chicken exhibits antilisterial activity both before and after cooking, and therefore may provide protection to consumers against bacterial postprocessing recontaminations and/or undercooking. Application of pediocin to food packaging films may constitute an alternative approach to control *L. monocytogenes* in meats and poultry. Ming et al.¹⁶⁹ obtained a pediocin PA-1 extract from milk-based media and prepared antilisterial cellulose casings by internal coating with the pediocin powder (7.75 µg cm⁻²). The coated bags completely inhibited growth of inoculated *L. monocytogenes* through 12 weeks storage at 4°C.

B. Milk and Dairy Products

Inhibition of *L. monocytogenes* has been demonstrated in several dairy systems, including dressed Cottage cheese, half-and-half cream, and cheese sauce.⁵³ In all these food systems, there was a rapid decrease in viable counts of *L. monocytogenes* in the presence of pediocin PA-1 powder over the pH range 5.5 to 7.0 and at both 4 and 32°C. Although a resurgence of the pathogen after 7 days at 4°C in the mildly acidic and neutral dairy systems was described, decreases in *Listeria* populations of at least 2 log cycles were observed in such substrates. As cited above, Motlagh et al.⁶² and Degnan et al.¹⁶⁷ also reported the antilisterial activity of pediocin PA-1 in dairy products.

Despite the fact that pediococci are poorly adapted to dairy substrates, it has been reported that different pediocin-producing *P. acidilactici* strains may contribute to *L. monocytogenes* control in milk when a very high inoculum (10⁹ cfu ml⁻¹) is used.¹⁷⁰ In contrast, the pediocin producer *Lb. plantarum* WHE 92 was originally isolated from a smear-surface soft cheese¹⁷ and, therefore, it must be well-adapted to this dairy environment.

In fact, the presence of *L. monocytogenes* in Munster cheese could be prevented by spraying a cell suspension of *Lb. plantarum* WHE 92 on the cheese surface at the beginning of the ripening period.¹⁴¹ Although *L. monocytogenes* was sometimes detected at low levels (<50 cfu g⁻¹) after 7 to 11 days of ripening, this microorganism was unable to grow or survive in the presence of the bacteriocin-producing strain in any of the samples examined until the end of ripening (21 days). The pathogen often reached counts higher than 10⁴ cfu ml⁻¹ in control samples. *Lb. plantarum* WHE 92 did not interfere with the ripening process.

The *L. lactis* LL108 strain producing pediocin PA-1¹²² lacks several properties required for application in milk and dairy products.¹⁷¹ Therefore, in order to fully exploit the commercial potential of a pediocin-producing dairy starter culture, *L. lactis* MM210, a strain that had been used previously in Cheddar cheese manufacturing, was selected as an alternative host for the *ped* operon-encoding plasmid.¹⁷¹ The antilisterial ability of the pediocin-producing *L. lactis* starter culture was tested in Cheddar cheeses coinoculated with the lactococcal strain and a mixture of three *L. monocytogenes* strains.¹⁷¹ In the experimental cheese, the counts of the pathogen decreased by 1 log cycle within 1 week of ripening and then decreased by an additional log cycle within 3 months (final counts: 10 cfu g⁻¹). In control cheeses made with an isogenic, nonpediocin-producing *L. lactis* strain, *Listeria* counts increased by approximately 4 log cycles after 2 weeks of ripening and then gradually decreased to about 10³ cfu g⁻¹ after 6 months. The presence of the plasmid encoding heterologous pediocin production in the lactococcal starter culture did not affect its cheese-making quality.

C. Other Foodstuffs

With respect to other foodstuffs, the addition of pediocin PA-1 to liquid whole egg containing *L. monocytogenes* showed an immediate reduction in listerial counts and led to a greater reduction (of up to 1 log cycle) during heating when compared with the levels found after heating untreated liquid whole egg.⁴⁵ The addition of pediocin PA-1 during fermentation of a vegetable (kimchi)

also notably decreased *L. monocytogenes* counts and inhibited its growth during a minimum of 16 days.¹⁷²

D. Legal Status

Up to date, nisin has been the only bacteriocin licenced as food preservative, although the antimicrobial potential of pediocin PA-1 has already been commercially exploited as a pediocin PA-1-containing fermentate. Owing to their typical association with food fermentation and their long tradition as food-grade bacteria, pediocin PA-1-producing LAB are “generally recognized as safe” (GRAS), and therefore the benefits of this bacteriocin can already be exploited using the producer strains or their fermentates, a practice for which special labeling would not be required.¹⁷³ In fact, a wide use of bacteriocin-producing LAB in food fermentations has inadvertently or empirically been made for centuries, and it seems clear that bacteriocin residues are present in our daily food supply.⁷ Currently, there are some European and US patents covering the use of pediocin PA-1 in dairy¹⁷⁴ and meat products.^{175,176}

VIII. CONCLUSION AND FUTURE PROSPECTS

Many LAB bacteriocins have been identified over the years¹ but only nisin, and pediocin PA-1 have been examined extensively in application studies in food systems. Although pediocin PA-1 has an antimicrobial spectrum not as wide as that of nisin, it is generally more active against *Listeria monocytogenes*. The fact that this microorganism is of special concern to the food industry, because of the high mortality and morbidity rates associated with listeriosis,⁴⁵ may help to increase the use of pediocin PA-1 as a food biopreservative.

Pediocin PA-1 has been the subject of considerable interest in recent years. However, there are still many aspects that need further research. Its three-dimensional structure and mode of action are far from completely elucidated. The establishment of the relationships between its structure

and its biological activity will be of particular interest because this knowledge may facilitate the enhancement of pediocin PA-1 activity and a greater understanding of the mechanisms of bacterial resistance to the peptide. Protein engineering, genetic engineering, and/or chemical synthesis may lead to the development of new antimicrobial peptides with improved properties, based on some features of the pediocin PA-1 molecule (pediocin PA-1 variants, hybrid bacteriocins). The use of genetically modified organisms for the *in situ* production of pediocin PA-1 may meet with opposition from industries and/or consumers. Therefore, the development of (inducible) "food-grade" genetic systems for pediocin PA-1 production would be highly relevant. Enhancement of the pediocin PA-1 productivity when it is heterologously (co)produced by starter cultures may contribute to widen the applicability of pediocin PA-1 in foodstuffs.

The approval of pediocin PA-1 as a food additive would require the existence of methods that allow the specific detection of this bacteriocin in foods. The recent development of specific polyclonal antibodies is a promising step in this direction. Specific antibodies could also facilitate the (industrial scale) purification of pediocin PA-1 through the use of immunoaffinity columns.

Inasmuch as different laboratories worldwide are working on the elucidation of all these points, we are confident that pediocin PA-1 or pediocin PA-1-like peptides will be included in the next generation of food preservatives.

ACKNOWLEDGMENTS

The authors are grateful to G. Fimland for sharing data prior to publication.

REFERENCES

1. Jack, R. W., Tagg, J. R., and Ray, B., Bacteriocins of Gram positive bacteria. *Microbiol. Rev.*, 59, 171–200, 1995.
2. De Vuyst, L. and Vandamme, E. J., Lactic acid bacteria and bacteriocins: their practical importance. In: *Bacteriocins of Lactic Acid Bacteria*, De Vuyst, L. and Vandamme, E. J., Eds., Chapman and Hall, Glasgow, 1994, 1–11.
3. Klaenhammer, T. R., Genetics of bacteriocins produced by lactic acid bacteria. *FEMS Microbiol. Rev.*, 12, 39–86, 1993.
4. Nes, I. F., Diep, D. B., Håvarstein, L. S., and Brurberg, M. B., Biosynthesis of bacteriocins in lactic acid bacteria. *Antonie van Leeuwenhoek Int. J. Gen. Mol. Microbiol.*, 70, 113–128, 1996.
5. Nissen-Meyer, J. and Nes, I. F., Ribosomally synthesized antimicrobial peptides: their function, structure, biogenesis, and mechanism of action. *Arch. Microbiol.*, 167, 67–77, 1997.
6. Delves-Broughton, J., Nisin and its uses as a food biopreservative. *Food Technol.* 44, 100–117, 1990.
7. Stiles, M. E., Biopreservation by lactic acid bacteria. *Antonie van Leeuwenhoek Int. J. Gen. Mol. Microbiol.*, 70, 331–345, 1996.
8. Gonzalez, C. F. and Kunka, B. S., Plasmid-associated bacteriocin production and sucrose fermentation in *Pediococcus acidilactici*. *Appl. Environ. Microbiol.* 53, 2534–2538, 1987.
9. Bhunia, A. K., Johnson M. G., and Ray B., Direct detection of an antimicrobial peptide of *Pediococcus acidilactici* in sodium dodecyl sulfate-polyacrylamide gel electrophoresis. *J. Industrial Microbiol.*, 2, 319–322, 1987.
10. Bhunia, A. K., Johnson M. G., and Ray B., Purification, characterization and antimicrobial spectrum of a bacteriocin produced by *Pediococcus acidilactici*. *J. Appl. Bacteriol.*, 65, 261–268, 1988.
11. Hoover, D. G., Walsh, P. M., Kolaetis, K. M., and Daly, M. M., A bacteriocin produced by *Pediococcus* species associated with a 5,5 megadalton plasmid. *J. Food Prot.*, 59, 29–31, 1988.
12. Luchansky, J. B., Glass, K. A., Harsono, K. D., Degnan, A. J., Faith, N. G., Cauvin, B., Baccus-Taylor, G., Arihara, K., Bater, B., Maurer, A. J., and Cassen, R. G., Genomic analysis of *Pediococcus acidilactici* in turkey summer sausage. *Appl. Environ. Microbiol.*, 58, 3053–3059, 1992.
13. Christensen, D. P. and Hutkins, R. B., Collapse of the proton motive force in *Listeria monocytogenes* caused by a bacteriocin produced by *Pediococcus acidilactici*. *Appl. Environ. Microbiol.*, 58, 3312–3315, 1992.
14. Moreira, W. L., *Aislamiento y caracterización parcial de una bacteriocina producida por Pediococcus sp. 347, de origen cárnico*. PhD Thesis, Universidad Complutense. Madrid, Spain, 1993.
15. Schved, F. Lalazar, A. Henis, Y., and Juven, B. J., Purification, partial characterization and plasmid linkage of pediocin SJ-1, a bacteriocin produced by *Pediococcus acidilactici*. *J. Appl. Bacteriol.*, 74, 67–77, 1993.
16. Daba, H., Lacroix, C., Huang, J., Simard, R. E., and Lemieux, L., Simple method of purification and sequencing of a bacteriocin produced by *Pediococcus acidilactici* UL5. *J. Appl. Bacteriol.*, 77, 682–688, 1994.
17. Ennahar, S., Aoude-Werner, D., Sorokine, O., van Dorselaer, A., Bringel, F., Hubert, J. C., and

- Hasselmann, C., Production of pediocin AcH by *Lactobacillus plantarum* WHE92 isolated from cheese. *Appl. Environ. Microbiol.*, 62, 4381–4387, 1996.
18. **Bennik, M. H. J., Verheul, A., Abee, T., Naaktgeboren-Stoffels, G., Gorris, L. G. M., and Smid, E. J.**, Interactions of nisin and pediocin PA-1 with closely related lactic acid bacteria that manifest over 100-fold differences in bacteriocin sensitivity. *Appl. Environ. Microbiol.*, 63, 3628–3636, 1997.
 19. **Rodríguez, J. M., Cintas, L. M. Casaus, P., Martínez, M. I., Suárez, A., and Hernández, P. E.**, Detection of pediocin PA-1 producing pediococci by rapid molecular producing by rapid molecular biology techniques. *Food Microbiol.*, 14, 363–37, 1997.
 20. **Henderson, J. T., Chopko, A. L., and van Wassenaar, P. D.**, Purification and primary structure of pediocin PA-1 produced by *Pediococcus acidilactici* PAC1.0. *Arch. Biochem. Biophys.*, 295, 5–12, 1992.
 21. **Nieto-Lozano, J. C., Nissen-Meyer, J., Sletten, K., Peláez, C., and Nes, I. F.**, Purification and amino acid sequence of a bacteriocin produced by *Pediococcus acidilactici*. *J. Gen. Microbiol.*, 138, 1–6, 1992.
 22. **Marugg, J. D., González, C. F., Kunka, B. S., Ledebøer, A. M., Pucci, M. J., Toonen, M. Y., Walker, S. A., Zoetmulder, L. C. M., and Vandenberg, P. A.**, Cloning, expression, and nucleotide sequence of genes involved in production of pediocin PA-1, a bacteriocin from *Pediococcus acidilactici* PAC1.0. *Appl. Environ. Microbiol.*, 58, 2360–2367, 1992.
 23. **Motlagh, A. M., Bhunia, A. K., Szosteck, F., Hansen, T. R., Johnson, M. C., and Ray, B.**, Nucleotide and amino acid sequence of *pap*-gene (pediocin AcH production) in *Pediococcus acidilactici* H. *Lett. Appl. Microbiol.*, 15, 45–48, 1992.
 24. **Fimland, G., Blingsmo, O. R., Sletten, K., Jung, G., Nes, I. F., and Nissen-Meyer, J.**, New biologically active hybrid bacteriocins constructed by combining regions from various pediocin-like bacteriocins: the C-terminal region is important for determining specificity. *Appl. Environ. Microbiol.*, 62, 3313–3318, 1996.
 25. **Chikindas, M. L., García-Garcerá, M. J., Driessen, A. J. M., Ledebøer, A. M., Nissen-Meyer, J., Nes, I. F., Abee, T., Konings, W. N., and Venema, G.**, Pediocin PA-1, a bacteriocin from *Pediococcus acidilactici* PAC1.0, forms hydrophilic pores in the cytoplasmic membrane of target cells. *Appl. Environ. Microbiol.*, 59, 3577–3584, 1993.
 26. **Eijsink, V. G. H., Skeie, M., Middelhoven, P. H., Brurberg, M. B., and Nes, I. F.**, Comparative studies of class IIa bacteriocins of lactic acid bacteria. *Appl. Environ. Microbiol.*, 64, 3275–3281, 1998.
 27. **Chen, Y., Shapira, R., Eisenstein, M., and Montville, T. J.**, Functional characterization of pediocin PA-1 binding to liposomes in the absence of a protein receptor and its relationship to a predicted tertiary structure. *Appl. Environ. Microbiol.*, 63, 524–531, 1997.
 28. **Chen, Y., Ludescher, R. D., and Montville, T. J.**, Electrostatic interactions, but not the YGNV consensus motif, govern the binding of pediocin PA-1 and its fragments to phospholipid vesicles. *Appl. Environ. Microbiol.*, 63, 4770–4777, 1997.
 29. **Venema, K., Chikindas, M. L., Seegers, J. F. M. L., Haandrikman, A. J., Leenhouts, K. J., Venema, G., and Kok, J.**, Rapid and efficient purification method for small, hydrophobic, cationic bacteriocins: purification of lactococcin B and pediocin PA-1. *Appl. Environ. Microbiol.*, 63, 305–309, 1997.
 30. **Fimland, G., Jack, R., Jung, G., Nes, I. F., and Nissen-Meyer, J.**, The bactericidal activity of pediocin PA-1 is specifically inhibited by a 15-mer fragment that spans the bacteriocin from the center towards the C terminus. *Appl. Environ. Microbiol.*, 64, 5057–5060, 1998.
 31. **Sailer, M., Helms, G. L., Henkel, T., Niemczura, W. P., Nakashima, T. T., Stiles, M. E., and Vederas, J. C.**, ¹⁵N- and ¹³C-labeled media from *Anabaena* sp. for universal isotopic labeling of bacteriocins: NMR resonance assignments of leucocin A from *Leuconostoc gelidum* and nisin A from *Lactococcus lactis*. *Biochemistry*, 32, 310–318, 1993.
 32. **Ray, B.**, Pediocins of *Pediococcus* species. In: *Bacteriocins of Lactic Acid Bacteria*, De Vuyst, L. and Vandamme, E. J. Eds., Chapman and Hall, Glasgow, 1994, 465–495.
 33. **Fimland, G., Johnsen, L., Axelsson, L., Brurberg, M. B., Nes, I. F., Eijsink, V. G. H., and Nissen-Meyer, J.**, A C-terminal disulfide bridge in pediocin-like bacteriocins renders bacteriocin activity less temperature dependent and is a major determinant of the antimicrobial spectrum. *J. Bacteriol.*, 182, 2643–2648, 2000.
 34. **Ray, S. K., Kim, W. J., Johnson, M. C., and Ray, B.**, Conjugal transfer of a plasmid encoding bacteriocin production and immunity in *Pediococcus acidilactici* H. *J. Appl. Bacteriol.*, 66, 393–399, 1989.
 35. **Yang, R., Johnson, M. C., and Ray, B.**, Novel method to extract large amounts of bacteriocins from lactic acid bacteria. *Appl. Environ. Microbiol.*, 58, 3355–3359, 1992.
 36. **Holo, H., Nissen, O., and Nes, I. F.**, Lactococcin A, a new bacteriocin from *Lactococcus lactis* subsp. *cremoris*: isolation and characterization of the protein and its gene. *J. Bacteriol.*, 173, 3879–3887, 1991.
 37. **Nissen-Meyer, J., Holo, H., Håvarstein, L. S., Sletten, K., and Nes, I. F.**, A novel lactococcal bacteriocin whose activity depends on the complementary action of two peptides. *J. Bacteriol.*, 174, 5686–5692, 1992.
 38. **Horn, N., Martínez, M. I., Martínez, J. M., Hernández, P. E., Gasson, M. J., Rodríguez, J. M., and Dodd, H. M.**, Production of pediocin PA-1 by *Lactococcus lactis* using the lactococcin A secretory apparatus. *Appl. Environ. Microbiol.*, 64, 818–823, 1998.
 39. **Horn, N., Martínez, M. I., Martínez, J. M., Hernández, P. E., Gasson, M. J., Rodríguez, J. M.,**

- and Dodd, H. M., Enhanced production of pediocin PA-1, and coproduction of nisin and pediocin PA-1, by *Lactococcus lactis*. *Appl. Environ. Microbiol.*, 65, 4443–4450, 1999.
40. Martínez, J. M., Martínez, M. I., Suárez, A. M., Herranz, C., Casaus, P., Cintas, L. M., Rodríguez, J. M., and Hernández, P. E., Generation of polyclonal antibodies of predetermined specificity against pediocin PA-1. *Appl. Environ. Microbiol.*, 64, 4536–4545, 1998.
 41. Martínez, J. M., Martínez, M. I., Herranz, C., Cintas, L. M., Rodríguez, J. M., and Hernández, P. E., Polyclonal antibodies of predetermined specificity against a synthetic 1–9 N-terminal fragment of pediocin PA-1: specificity and cross-reactivity with other class IIa bacteriocins. *Microbiology*, 145, 2777–2787, 1999.
 42. Guyonnet, D., Fremaux, C., Cenatiempo, Y. and Berjeaud, J. M., Method for rapid purification of class IIa bacteriocins and comparison of their activities. *Appl. Environ. Microbiol.*, 66, 1744–1748.
 43. Suárez, A. M., Rodríguez, J. M., Morales, P., Hernández, P. E., and Azcona-Olivera, J. I., Development of monoclonal antibodies to the lantibiotic nisin A. *J. Agric. Food Chem.*, 44, 2936–2940, 1996.
 44. Suárez, A. M., Azcona, J. I., Rodríguez, J. M., Sanz, B., and Hernández, P. E., One-step purification of nisin A by immunoaffinity chromatography. *Appl. Environ. Microbiol.*, 63, 4990–4992, 1997.
 45. Muriana, P. M., Bacteriocins for control of *Listeria* spp. in food. *J. Food Prot.*, Suppl., 54–63, 1996.
 46. Fimland, G., Johnsen, L., Brurberg, M. B., Axelsson, L., Nes, I. F. Eijsink, V., and Nissen-Meyer, J., Structure-function analysis of sakacin P and pediocin PA-1 by site-directed mutagenesis. *Abstracts of the Sixth Symposium on Lactic Acid Bacteria: Genetics, Metabolism and Applications*, FEMS, Veldhoven, The Netherlands, C83, 1999.
 47. Kalchayanand, N., Hanlin, M. B., and Ray, B., Sublethal injury makes Gram-negative and resistant Gram-positive bacteria sensitive to the bacteriocins, pediocin AcH and nisin. *Lett. Appl. Microbiol.*, 15, 239–243, 1992.
 48. Kalchayanand, N., Sikes, A., Dunne, C. P., and Ray, B., Factors influencing death and injury of foodborne pathogens by hydrostatic pressure-pasteurization. *Food Microbiol.*, 15, 207–214, 1998.
 49. Kalchayanand, N., Sikes, A., Dunne, C. P., and Ray, B., Interaction of hydrostatic pressure, time and temperature of pressurization and pediocin AcH on inactivation of foodborne bacteria. *J. Food Prot.*, 61, 425–431, 1998.
 50. Ray, B., Pediocin(s) of *Pediococcus acidilactici* as a food biopreservative. In: *Food Biopreservatives of Microbial Origin*, Ray, B. and Daeschel, M., Eds., CRC Press, Boca Raton, 1992, 265–322.
 51. Ray, B., Sublethal injury, bacteriocins and food microbiology. *ASM News*, 45, 34–36, 1993.
 52. Tagg, J. R., Dajani, A. S., and Wannamaker, L. W., Bacteriocins of Gram-positive bacteria. *Bacteriol. Rev.*, 40, 722–756, 1976.
 53. Pucci, M. J., Vedamuthu, R. E. R., Kunka, B. S., and Vandenberg, P. A., Inhibition of *Listeria monocytogenes* by using bacteriocin PA-1 produced by *Pediococcus acidilactici* PAC1.0. *Appl. Environ. Microbiol.*, 54, 2349–2353, 1988.
 54. Bhunia, A. K., Johnson, M. C., Ray, B., and Kalchayanand, N., Mode of action of pediocin AcH from *Pediococcus acidilactici* H on sensitive bacterial strains. *J. Appl. Bacteriol.*, 70, 25–33, 1991.
 55. Venema, K., Kok, J., Marugg, J. D., Toonen, M. Y., Ledebor, A. M., Venema, G., and Chikindas, M. L., Functional analysis of the pediocin operon of *Pediococcus acidilactici* PAC1.0: PedB is the immunity protein and PedD is the precursor processing enzyme. *Mol. Microbiol.*, 17, 515–522, 1995.
 56. Geis, A., Singh, J., and Teuber, M., Potential of lactic streptococci to produce bacteriocin. *Appl. Environ. Microbiol.*, 45, 205–211, 1983.
 57. Blom, H., Katla, T., Hagen, B. F., and Axelsson, L., A model assay to demonstrate how intrinsic factors affect diffusion of bacteriocins. *Int. J. Food Microbiol.*, 38, 103–109, 1997.
 58. Rose, N. L., Sporns, P., and McMullen, L., Detection of bacteriocins by matrix-assisted laser desorption/ionization time-on-flight mass spectrometry. *Appl. Environ. Microbiol.*, 65, 2238–2242, 1999.
 59. Rasch, M. and Knochel, S., Variations in tolerance of *Listeria monocytogenes* to nisin, pediocin PA-1 and bavaricin A. *Lett. Appl. Microbiol.*, 27, 275–278, 1998.
 60. Dykes, G. A., Bacteriocins: ecological and evolutionary significance. *Trends Ecol. Evol.*, 10, 186–189, 1995.
 61. Dykes, G. A. and Hastings, J. W., Fitness costs associated with class IIa bacteriocin resistance in *Listeria monocytogenes* B73. *Lett. Appl. Microbiol.*, 26, 5–8, 1998.
 62. Motlagh, A. M., Holla, S., Johnson, M. C., Ray, B., and Field, R. A., Inhibition of *Listeria* spp. in sterile food systems by pediocin AcH, a bacteriocin produced by *Pediococcus acidilactici* H. *J. Food Prot.*, 55, 337–343, 1992.
 63. Murray, M. and Richard, J. A., Comparative study of the antilisterial activity of nisin A and pediocin AcH in fresh ground pork stored aerobically at 5°C. *J. Food Prot.*, 60, 1534–1540, 1997.
 64. Goff, J. H., Bhunia, A. K., and Johnson, M. G., Complete inhibition of low levels of *Listeria monocytogenes* on refrigerated chicken meat with pediocin AcH bound to heat-killed *Pediococcus acidilactici* cells. *J. Food Prot.*, 59, 1187–1192, 1996.
 65. Noerlis, Y. and Ray, B., Factors influencing immunity and resistance of *Pediococcus acidilactici* to bacteriocin pediocin AcH. *Lett. Appl. Microbiol.*, 18, 138–143, 1994.

66. **Rekhif, N., Atrih, A., and Levefre, G.,** Selection of spontaneous mutants of *Listeria monocytogenes* ATCC 15313 resistant to different bacteriocins produced by lactic acid bacteria strains. *Curr. Microbiol.*, 28, 237–241, 1994.
67. **Ming, X. and Daeschel, M. A.,** Nisin resistance of foodborne bacteria and the specific resistance responses of *Listeria monocytogenes* Scott-A. *J. Food Prot.*, 56, 944–948, 1993.
68. **Davies, E. A., Falahee, M. B., and Adams, M. R.,** Involvement of the cell envelope of *Listeria monocytogenes* in the acquisition of nisin resistance. *J. Appl. Bacteriol.*, 81, 139–146, 1996.
69. **Maisnier-Patin, S. and Richard, J.,** Cell wall changes in nisin-resistant variants of *Listeria innocua* grown in the presence of high nisin concentrations. *FEMS Microbiol. Lett.*, 140, 29–35, 1996.
70. **Goulhen, F., Meghrous, J., and Lacroix, C.,** Characterization of nisin-resistant strains of *Pediococcus acidilactici* UL5, a producer of pediocin. *J. Appl. Microbiol.*, 85, 387–397, 1998.
71. **Hanlin, M.B., Kalchayanand, N., Ray, P., and Ray, B.,** Bacteriocins of lactic acid bacteria in combination have greater antibacterial activity. *J. Food Prot.*, 56, 252–255, 1993.
72. **Mulet-Powell, N., Lacoste-Armynot, A. M., Viñas, M., and De Buochberg, M. S.,** Interactions between pairs of bacteriocins from lactic acid bacteria. *J. Food Prot.*, 61, 1210–1212, 1998.
73. **Montville, T. J. and Chen, Y.,** Mechanistic action of pediocin and nisin: recent progress and unresolved questions. *Appl. Microbiol. Biotechnol.*, 50, 511–519, 1998.
74. **Mitchell, P.,** Chemiosmotic coupling in oxidative and photosynthetic phosphorylation. *Biol. Rev. Cambridge Philos. Soc.*, 41, 445–502, 1966.
75. **Bruno, M. E. C., Kaiser, A., and Montville, T. J.,** Depletion of proton motive force by nisin in *Listeria monocytogenes* cells. *Appl. Environ. Microbiol.*, 58, 2255–2259, 1992.
76. **Gao, F. H., Abee, T., and Konings, W. N.,** Mechanism of action of the peptide antibiotic nisin in liposomes and cytochrome C oxidase-containing proteoliposomes. *Appl. Environ. Microbiol.*, 57, 2164–2170, 1991.
77. **Kordel, M., Schüller, F., and Sahl, H. G.,** Interaction of the pore-forming peptide antibiotics Pep5, nisin and subtilin with non-energized liposomes. *FEBS Lett.*, 224, 99–102, 1989.
78. **Okereke, A. and Montville, T. J.,** Nisin dissipates the proton motive force of the obligate anaerobe *Clostridium sporogenes* PA3679. *Appl. Environ. Microbiol.*, 58, 2463–2467, 1992.
79. **Ruhr, E. and Sahl, H. G.,** Mode of action of the peptide antibiotic nisin and influence of the membrane potential of whole cells and on cytoplasmic and artificial membrane vesicles. *Antimicrob. Agents Chemother.*, 27, 841–845, 1985.
80. **van Belkum, M. J., Hayema, B. J., Jeeninga, R. E., Kok, J., and Venema, G.,** Organization and nucleotide sequence of two lactococcal bacteriocin operons. *Appl. Environ. Microbiol.*, 57, 492–498, 1991.
81. **Venema, K., Abee, T., Haandrikman, A. J., Leenhouts, K. J., Kok, J., Konings, W. N., and Venema, G.,** Mode of action of lactococcin B, a thiol-activated bacteriocin from *Lactococcus lactis*. *Appl. Environ. Microbiol.*, 59, 1041–1048, 1993.
82. **Bruno, M. E. C. and Montville, T. J.,** Common mechanistic action of bacteriocins from lactic acid bacteria. *Appl. Environ. Microbiol.*, 59, 3003–3010, 1993.
83. **Driessen, A. J. M., van den Hooven, H. W., Kuiper, W., van den Kamp, M., Sahl, H. G., Konings, R. N. H., and Konings, W. N.,** Mechanistic studies of lantibiotic-induced permeabilization of phospholipid vesicles. *Biochemistry*, 34, 1606–1614, 1995.
84. **Chen, Y. and Montville, T. J.,** Efflux of ions and ATP depletion induced by pediocin PA-1 are concomitant with cell death in *Listeria monocytogenes* Scott A. *J. Appl. Bacteriol.*, 79, 684–690, 1995.
85. **Abee, T., Rombouts, F. M., Hugenholtz, J., Guihard, G., and Letellier, L.,** Mode of action of nisin Z against *Listeria monocytogenes* Scott A grown at high and low temperatures. *Appl. Environ. Microbiol.*, 60, 1962–1968, 1994.
86. **Winkowski, K., Bruno, M. E.C., and Montville, T. J.,** Correlation of bioenergetic parameters with cell death in *Listeria monocytogenes* cells exposed to nisin. *Appl. Environ. Microbiol.*, 60, 4186–4188, 1994.
87. **Kaiser, A. L. and Montville, T. J.,** Purification of the bacteriocin bavaricin MN and characterization of its mode of action against *Listeria monocytogenes* Scott A cells and lipid vesicles. *Appl. Environ. Microbiol.*, 62, 4529–4535, 1996.
88. **Winkowski, K., Ludescher, R. D., and Montville, T. J.,** Physicochemical characterization of the nisin-membrane interaction with liposomes derived from *Listeria monocytogenes*. *Appl. Environ. Microbiol.*, 62, 323–327, 1996.
89. **Chen, Y., Ludescher, R. D., and Montville, T. J.,** Influence of lipid composition of pediocin PA-1 binding to phospholipid vesicles. *Appl. Environ. Microbiol.*, 64, 3530–3532, 1998.
90. **El-Jastimi, R. and Lafleur, M.,** Structural characterization of free and membrane-bound nisin by infrared spectroscopy. *Biochim. Biophys. Acta*, 1324, 151–158, 1997.
91. **Bhugaloo-Vial, P., Douliez, J.P., Mollé, D., Dousset, X., Boyaval, P., and Marion, D.,** Delineation of key amino acid side chains and peptide domains for antimicrobial properties of divercin V41, a pediocin-like bacteriocin secreted by *Carnobacterium divergens* V41. *Appl. Environ. Microbiol.*, 65, 2895–2900, 1999.
92. **Quadri L. E. N., Sailer, M., Roy, K. L., Vederas, J. C., and Stiles, M. E.,** Chemical and genetic characterization of bacteriocins produced by *Carnobacterium*

- piscicola* LV 17B. *J. Biol. Chem.*, 269, 12204–12211, 1994.
93. **Hastings, J. W., Sailer, M., Johnson, K., Roy, K. L., Vederas, J. C., and Stiles, M. E.**, Characterization of leucocin A-UAL187 and cloning of the bacteriocin gene from *Leuconostoc gelidum*. *J. Bacteriol.*, 173, 7491–7500, 1991.
 94. **Fleury, Y., Dayem, M. A., Montagne, J. J., Chaboisseau, E., Caer, J. P., Nicolas, P., and Delfour, A.**, Covalent structure, synthesis, and structure-function studies of mesentericin Y105, a defensive peptide from Gram-positive bacteria *Leuconostoc mesenteroides*. *J. Biol. Chem.*, 271, 14421–14429, 1996.
 95. **Chen, Y.**, Physicochemical Characterization and Structure Function Relationship for the Interaction of Pediocin PA-1 with *Listeria monocytogenes* Cell and Lipid Vesicles. PhD thesis, The State University of New Jersey, New Jersey, 1998.
 96. **Miller, K. W., Schamber, R., Chen, Y., and Ray, B.**, Production of active chimeric pediocin PA-1 in *Escherichia coli* in the absence of processing and secretion genes from *Pediococcus pap* operon. *Appl. Environ. Microbiol.*, 64, 14–20, 1998.
 97. **Miller, K. W., Schamber, R., Chen, Osmanagaoglu, O., and Ray, B.**, Isolation and characterization of pediocin AcH chimeric protein mutants with altered bactericidal activity. *Appl. Environ. Microbiol.*, 64, 1997–2005, 1998.
 98. **Bhunja, A. K., Bhowmik, T. K., and Johnson, M. G.**, Determination of bacteriocin-encoding plasmids of *Pediococcus acidilactici* strains by Southern hybridization. *Lett. Appl. Microbiol.*, 18, 168–170, 1994.
 99. **Jager, K. and Harlander, S.**, Characterization of a bacteriocin from *Pediococcus acidilactici* PC and comparison of bacteriocin-producing strains using molecular typing procedures. *Appl. Microbiol. Biotechnol.*, 37, 631–637, 1992.
 100. **Ray, B., Motlagh, A. M., Johnson, M. C., and Bozoglu, F.**, Mapping of pSMB74, a plasmid encoding bacteriocin AcH production (Pap+) trait in *Pediococcus acidilactici* H. *Lett. Appl. Microbiol.*, 15, 35–37, 1992.
 101. **van der Vossen, J. M. B. M., van der Lelie, D., and Venema, G.**, Isolation and characterization of *Streptococcus cremoris* Wg2-specific promoters. *Appl. Environ. Microbiol.*, 53, 2452–2457, 1987.
 102. **Motlagh, A. M., Bukhtiyarova, M., and Ray, B.**, Complete nucleotide sequence of pSMB74, a plasmid encoding the production of pediocin AcH in *Pediococcus acidilactici*. *Lett. Appl. Microbiol.*, 18, 305–312, 1994.
 103. **Kleerebezem, M., Quadri, L. E. N., Kuipers, O. P., and de Vos, W. M.**, Quorum sensing by peptide pheromones and two-component signal-transduction systems in Gram-positive bacteria. *Mol. Microbiol.*, 24, 895–904, 1997.
 104. **Håvarstein, L. S., Holo, H., and Nes, I. F.**, The leader peptide of colicin V shares consensus sequences with the leader peptides that are common among peptide bacteriocins produced by Gram-positive bacteria. *Microbiology*, 140, 2383–2389, 1994.
 105. **Håvarstein, L. S., Diep, D. B., and Nes, I. F.**, A family of bacteriocin ABC transporters carry out proteolytic processing of their substrates concomitant with export. *Mol. Microbiol.*, 16, 229–240, 1995.
 106. **Ray, B., Schamber, R., and Miller, K. W.**, The pediocin AcH precursor is biologically active. *Appl. Environ. Microbiol.*, 65, 2281–2286, 1999.
 107. **Fimland, G., Nes, I. F., Eijssink, V., and Nissen-Meyer, J.**, Structure function studies of immunity proteins from the pediocin-family. Abstracts of the Sixth Symposium on Lactic Acid Bacteria: Genetics, Metabolism and Applications, FEMS, Veldhoven, The Netherlands, C81, 1999.
 108. **Dinh, T., Paulsen, I. T., and Saier, J.**, A family of extracytoplasmic proteins that allow transport of large molecules across the outer membranes of Gram-negative bacteria. *J. Bacteriol.*, 176, 3825–3831, 1994.
 109. **Wandersman, C.**, Secretion across the bacterial outer membrane. *Trends Genet.*, 8, 317–322, 1992.
 110. **Schüle, R., Gentschev, I., Mollenkopf, H. J., and Goebel, W.**, A topological model for the haemolysin translocator protein HlyD. *Mol. Gen. Genet.*, 234, 155–163, 1992.
 111. **Stoddard, G. W., Petzel, J. P., Van Belkum, M. J., Kok, J., and McKay, L. L.**, Molecular analyses of the lactococcal A gene cluster from *Lactococcus lactis* subsp. *lactis* biovar *diacetylactis* WM4. *Appl. Environ. Microbiol.*, 58, 1952–1961, 1992.
 112. **Salmond, G. P. C. and Reeves, P. J.**, Membrane traffic wardens and protein secretion in Gram-negative bacteria. *Trends Biochem. Sci.*, 18, 7–12, 1993.
 113. **Franke, C. M.**, Topology of a Type I Secretion System for Bacteriocins of *Lactococcus lactis*. PhD Thesis. University of Groningen, Holland, 1998.
 114. **Varcamonti, M., Nicastro, G., Venema, G., and Kok, J.**, Lactococcal A export in *Lactococcus lactis*. Abstracts of the Sixth Symposium on Lactic Acid Bacteria: Genetics, Metabolism and Applications, FEMS, Veldhoven, The Netherlands, C93, 1999.
 115. **Billman-Jacobe, H.**, Expression in bacteria other than *Escherichia coli*. *Curr. Opin. Biotech.*, 7, 499–504, 1996.
 116. **Olins, P. O.**, Expression systems. Quantity versus authenticity of heterologously produced proteins. *Curr. Opin. Biotech.*, 7, 487–488, 1996.
 117. **Allison, G. E., Worobo, R. W., Stiles, M. E., and Klaenhammer, T. R.**, Heterologous expression of the lactacin F peptides by *Carnobacterium piscicola* LV17. *Appl. Environ. Microbiol.*, 61, 1371–1377, 1995.
 118. **Ahn, C. and Stiles, M. E.**, Plasmid-associated bacteriocin production by a strain of *Carnobacterium piscicola* from meat. *Appl. Environ. Microbiol.*, 56, 2503–2510, 1990.
 119. **van Belkum, M. J., Worobo, R. W., and Stiles, M. E.**, Double-glycine-type leader peptides direct secre-

- tion of bacteriocins by ABC transporters: colicin V secretion in *Lactococcus lactis*. *Mol. Microbiol.*, 23, 1293–1301, 1997.
120. **Worobo, R. W., van Belkum, M. J., Sailer, M., Roy, K. L., Vederas, J. C., and Stiles M. E.**, A signal peptide secretion-dependent bacteriocin from *Carnobacterium divergens*. *J. Bacteriol.*, 177, 3143–3149, 1995.
 121. **van Belkum, M. J. and Stiles, M. E.**, Molecular characterization of genes involved in the production of the bacteriocin leucocin A from *Leuconostoc gelidum*. *Appl. Environ. Microbiol.*, 61, 3573–3579, 1995.
 122. **Chikindas, M.L., Venema, K., Ledebuer, A. M., Venema, G., and Kok, J.**, Expression of lactococcin A and pediocin PA-1 in heterologous hosts. *Lett. Appl. Microbiol.*, 21, 183–189, 1995.
 123. **Venema, K., Dost, M. H. R., Beun, P. A. H., Haandrikman, A. J., Venema, G., and Kok, J.**, The genes for secretion and maturation of lactococcins are located on the chromosome of *Lactococcus lactis* IL1403. *Appl. Environ. Microbiol.*, 62, 1689–1692, 1996.
 124. **Gasson, M.J. and Anderson, P.H.**, High copy number plasmid vectors for use in lactic streptococci. *FEMS Microbiol. Letts.*, 30, 193–196, 1985.
 125. **Martínez, J.M., Kok, J., Sanders, J.W. and Hernández, P.E.**, Heterologous co-production of enterocin A and pediocin PA-1 by *Lactococcus lactis*: detection by specific peptide-directed antibodies. *Appl. Environ. Microbiol.*, 66, 3543–3549, 2000.
 126. **Coderre, P. E. and Somkuti, G. A.**, Cloning and expression of the pediocin operon in *Streptococcus thermophilus* and other lactic fermentation bacteria. *Curr. Microbiol.*, 39, 295–301, 1999.
 127. **Eckart, M. R. and Bussineau, C. M.**, Quality and authenticity of heterologous proteins synthesized in yeast. *Curr. Opin. Biotech.*, 7, 525–530, 1996.
 128. **Schoeman, H., Vivier, M. A., du Toit, M., Dicks, L. M. T., and Pretorius, I. S.**, The development of bactericidal yeast strains by expressing the *Pediococcus acidilactici* pediocin gene (*pedA*) in *Saccharomyces cerevisiae*. *Yeast*, 15, 647–656, 1999.
 129. **Cregg, J. M., Vedvick, T. S., and Raschke, W. C.**, Recent advances in the expression of foreign genes in *Pichia pastoris*. *Bio-Technology*, 11, 905–909, 1993.
 130. **Faber, K. N., Harder, W., Ab, G., and Veenhuis, M.**, Methylophilic yeasts as factories for the production of foreign proteins. *Yeast*, 11, 1331–1344, 1995.
 131. **Sudbery, P. E.**, The expression of recombinant proteins in yeasts. *Curr. Opin. Biotech.*, 7, 517–524, 1996.
 132. **Kuipers, O. P., Beerthuyzen, M. M., de Ruyter, P. G. G. A., Luesink, E. J., and de Vos, W. M.**, Auto-regulation of nisin biosynthesis in *Lactococcus lactis* by signal transduction. *J. Biol. Chem.*, 270, 27299–27304, 1995.
 133. **de Ruyter, P. G. G. A., Kuipers, O. P., Beerthuyzen, M. M., van Alenboerriqter, I. J., and de Vos, W. M.**, Functional analysis of promoters in the nisin gene cluster of *Lactococcus lactis*. *J. Bacteriol.*, 178, 3434–3439, 1996.
 134. **de Ruyter, P. G. G. A., Kuipers, O. P., and de Vos, W. M.**, Controlled gene expression systems for *Lactococcus lactis* with the food-grade inducer nisin. *Appl. Environ. Microbiol.*, 62, 3662–3667, 1996.
 135. **Kuipers, O. P., de Ruyter, P. G. G. A., Kleerebezem, M., and de Vos, W. M.**, Controlled overproduction of proteins by lactic acid bacteria. *Trends Biotechnol.* 15, 135–140, 1997.
 136. **Sanders, J. W., Venema, G., and Kok, J.**, A chloride-inducible gene expression cassette and its use in induced lysis of *Lactococcus lactis*. *Appl. Environ. Microbiol.*, 63, 4877–4882, 1997.
 137. **Sanders, J. W., Leenhouts, K., Burghoorn, J., Brands, J. R., Venema, G., and Kok, J.**, A chloride-inducible acid resistance mechanism in *Lactococcus lactis* and its regulation. *Mol. Microbiol.*, 27, 299–310, 1998.
 138. **Kemperman, R., Sanders, J.W., Venema, G., and Kok, J.**, Enhanced secretion of pediocin PA-1 by overexpression of the accessory protein PedC. *Abstracts of the Sixth Symposium on Lactic Acid Bacteria: Genetics, Metabolism and Applications*, FEMS, Veldhoven, The Netherlands, C80, 1999.
 139. **Yang, R. and Ray, B.**, Factors influencing production of bacteriocins by lactic acid bacteria. *Food Microbiol.*, 11, 281–291, 1994.
 140. **Biswas, S. R., Purbita, R., Johnson, M. C., and Ray, B.**, Influence of growth conditions on the production of a bacteriocin, pediocin AcH, by *Pediococcus acidilactici* H. *Appl. Environ. Microbiol.*, 57, 1265–1267, 1991.
 141. **Ennahar, S., Assobhel, O., and Hasselmann, C.**, Inhibition of *Listeria monocytogenes* in a smear-surface soft cheese by *Lactobacillus plantarum* WHE92, a pediocin AcH producer. *J. Food Prot.*, 61, 186–191, 1998.
 142. **Ray, B., Motlagh, A. M., and Johnson, M. C.**, Processing of prepediocin in *Pediococcus acidilactici*. *FEMS Microbiol. Rev.*, 12, 119, 1993.
 143. **Goulhen, F., Meghrous, J., and Lacroix, C.**, Production of a nisin Z pediocin mixture by pH-controlled mixed-strain batch cultures in supplemented whey permeate. *J. Appl. Microbiol.*, 86, 399–406, 1999.
 144. **Bhunja, A. K., Johnson, M. C., Ray, B., and Belden, E. L.**, Antigenic property of pediocin AcH produced by *Pediococcus acidilactici* H. *J. Appl. Bacteriol.*, 69, 211–215, 1990.
 145. **Martínez, M. I., Rodríguez, J. M., Suárez, A., Martínez, J. M., Azcona, J. I., and Hernández, P. E.**, Generation of polyclonal antibodies against a chemically synthesized N-terminal fragment of the bacteriocin pediocin PA-1. *Lett. Appl. Microbiol.*, 24, 488–492, 1997.
 146. **Martínez, J. M., Martínez, M. ., Herranz, C., Morales, P., Fernández, M. F., Cintas, L. M.,**

- Rodríguez, J. M., and Hernández, P. E., Use and limitations of antipeptide antibodies for detection and immunopurification of pediocin PA-1. Abstracts of the Sixth Symposium on Lactic Acid Bacteria: Genetics, Metabolism and Applications, FEMS, Veldhoven, The Netherlands, C39, 1999.
147. Wu, W. H., Rule, D. C., Busboom, J. R., Field, R. A., and Ray, B., Starter culture and time/temperature storage influences on quality of fermented mutton sausages. *J. Food Sci.*, 56, 916–919, 1991.
 148. Suárez, A. M., Rodríguez, J. M., Hernández P. E., and Azcona-Olivera, J. I., Generation of polyclonal antibodies against nisin: immunization strategies and immunoassays development. *Appl. Environ. Microbiol.*, 62, 2117–2121, 1996.
 149. Bhunia, A. K., Monoclonal antibody-based enzyme immunoassay for pediocins of *Pediococcus acidilactici*. *Appl. Environ. Microbiol.*, 60, 2692–2696, 1994.
 150. Bouksaim, M., Fliss, I., Meghrou, J., Simard, R., and Lacroix, C., Immunodot detection of nisin Z in milk and whey using enhanced chemiluminescence. *J. Appl. Microbiol.*, 84, 176–184, 1998.
 151. Aymerich, T., Holo, H., Håvarstein, L. S., Hugas, M., Garriga, M., and Nes, I. F., Biochemical and genetic characterization of enterocin A from *Enterococcus faecium*, a new antilisterial bacteriocin in the pediocin family of bacteriocins. *Appl. Environ. Microbiol.*, 62, 1676–1682.
 152. Dyson, H. J. and Wright, P. E., Antigenic peptides. *FASEB J.*, 9, 37–42, 1995.
 153. Walter, G., Production and use of antibodies against synthetic peptides. *J. Immunol. Methods*, 88, 149–161.
 154. Tam, J. P., Recent advances in multiple antigen peptides. *J. Immunol. Methods*, 196, 17–32, 1996.
 155. Rolland, M. P., Bitri, L., and Besancon, P., Monospecificity of the antibodies to bovine α_{s1} -casein fragment 140–149: application to the detection of bovine milk in caprine dairy products. *J. Dairy Res.*, 62, 83–88, 1995.
 156. Schillinger, U., Geisen, R., and Holzapfel, W. H., Potential of antagonistic microorganisms and bacteriocins for the biological preservation of foods. *Trends Food Sci. Technol.*, 7, 158–164, 1996.
 157. Daeschel, M. A., Applications and interactions of bacteriocins from lactic acid bacteria in food and beverages. In: *Bacteriocins of Lactic Acid Bacteria*, Hoover, D.G. and Steenson, L. R., Eds., Academic Press, San Diego, 1993, 63–91.
 158. Leistner, L., Food preservation by combined methods. *Food Res. Int.*, 25, 151–158, 1992.
 159. Kalchayanand, N., Extension of Shelf-Life of Vacuum-Packaged Refrigerated Fresh Beef by Bacteriocins of Lactic Acid Bacteria. PhD Thesis, University of Wyoming, 1990.
 160. Nielsen, J. W., Dickson, J. S., and Crouse, J. D., Use of a bacteriocin produced by *Pediococcus acidilactici* to inhibit *Listeria monocytogenes* associated with fresh meat. *Appl. Environ. Microbiol.*, 56, 2142–2145, 1990.
 161. Berry, E. D., Liewen, M. B., Mandigo, R. W., and Hutkins, R. W., Inhibition of *Listeria monocytogenes* by bacteriocin producing *Pediococcus* during the manufacture of fermented semidry sausage. *J. Food Prot.*, 53, 194–199, 1990.
 162. Foegeding, P. M., Thomas, A. B., Pilkington, D. H., and Klaenhammer, T. R., Enhanced control of *Listeria monocytogenes* by in situ-produced pediocin during dry fermented sausage production. *Appl. Environ. Microbiol.*, 58, 884–890, 1992.
 163. Berry, E. D., Hutkins, R. W., and Mandigo, R. W., The use of bacteriocin producing *Pediococcus acidilactici* to control postprocessing *Listeria monocytogenes* contamination in frankfurters. *J. Food Prot.*, 54, 681–686, 1991.
 164. Yousef, A. E., Luchansky, J. B., Degnan, A. J., and Doyle, M. D., Behavior of *Listeria monocytogenes* in wiener exudates in the presence of *Pediococcus acidilactici* H or pediocin AcH during storage at 4 or 25°C. *Appl. Environ. Microbiol.*, 57, 1461–1467, 1991.
 165. Degnan, A. J., Yousef, A. E., and Luchansky, J. B., Use of *Pediococcus acidilactici* to control *Listeria monocytogenes* in temperature-abused vacuum-packaged wieners. *J. Food Prot.*, 55, 98–103, 1992.
 166. Schlyter, J. H., Glass, K. A., Loeffelholz, J., Degnan, A. J., and Luchansky, J. B., The effects of diacetate with nitrite, lactate, or pediocin on the viability of *Listeria monocytogenes* in turkey slurries. *Int. J. Food Microbiol.*, 19, 271–281, 1993.
 167. Degnan, A. J., Buyong, N., and Luchansky, J. B., Antilisterial activity of pediocin AcH in model food systems in the presence of an emulsifier or encapsulated within liposomes. *Int. J. Food Microbiol.*, 18, 127–138, 1993.
 168. Khojasteh, A. and Murano, E.A., Inability of heat stress to affect sensitivity of *Listeria monocytogenes* to pediocin in pork. *J. Food Safety*, 16, 201–208, 1996.
 169. Ming, X., Weber, G. H., Ayres, J. W., and Sandine, W. E., Bacteriocins applied to food packaging materials to inhibit *Listeria monocytogenes* on meats. *J. Food Sci.*, 62, 413–415, 1997.
 170. Raccach, M. and Geshell, D. J., The inhibition of *Listeria monocytogenes* in milk by pediococci. *Food Microbiol.*, 10, 181–186, 1993.
 171. Buyong, N., Kok, J., and Luchansky, J. B., Use of a genetically enhanced, pediocin-producing starter culture, *Lactococcus lactis* subsp. *lactis* MM217, to control *Listeria monocytogenes* in Cheddar cheese. *Appl. Environ. Microbiol.*, 64, 4842–4845, 1998.
 172. Choi, S. Y. and Beuchat, L. R., Growth inhibition of *Listeria monocytogenes* by a bacteriocin of *Pediococcus acidilactici* M during fermentation of kimchi. *Food Microbiol.*, 11, 301–307, 1994.
 173. Holzapfel, W. H., Geisen, R., and Schillinger, U., Biological preservation of foods with reference to

- protective cultures, bacteriocins and food-grade enzymes. *Int. J. Food Microbiol.*, 24, 343–362, 1995.
174. **Gonzalez, C. F.**, Method for Inhibiting Bacterial Spoilage. US Patent, 4883673, 1989.
175. **Vandenbergh, P. A., Pucci, M. J., Kunka, B. S., and Vedamuthu, E. R.**, Method for Inhibiting *List-eria monocytogenes* Using a Bacteriocin. *European Patent Application*, 89101125.6, 1989.
176. **Bourdreaux, D. P. and Matrozza, M. A.**, Method and Composition for Extending the Shelf-Life of Processed Meats. U.S. Patent, 5137319, 1992.