

Available online at www.sciencedirect.com**ScienceDirect**

Physics Procedia 90 (2017) 271 – 278

Physics

Procedia

Conference on the Application of Accelerators in Research and Industry, CAARI 2016,
30 October – 4 November 2016, Ft. Worth, TX, USA

A Distributed Data Acquisition System for the Sensor Network of the TAWARA_RTM Project

Cristiano Lino Fontana^{a*}, Massimiliano Donati^b, Davide Cester^a, Luca Fanucci^b,
Alessandro Iovene^c, Lukasz Swiderski^d, Sandra Moretto^a, Marek Moszynski^d,
Anna Olejnik^e, Alessio Ruii^b, Luca Stevanato^a, Tadeusz Batsch^d, Carlo Tintori^c,
Marcello Lunardon^a

^aDepartment of Physics and Astronomy "Galileo Galilei", University of Padua, Via Marzolo, 8, Padova PD 35131, Italy

^bDepartment of Information Engineering, University of Pisa, Via G. Caruso, 16, Pisa PI 56122, Italy

^cCAEN S.p.A., Via Vetraria, 11, Viareggio LU 55049, Italy

^dNarodowe Centrum Badan Jadrowyc, ul. Andrzeja Soltana 7, Otwock 05-400, Poland

^eMiejskie Przedsiębiorstwo Wodociagow i Kanalizacji, pl. Starynkiewicza 5, Warszawa 02-015, Poland

Abstract

This paper describes a distributed Data Acquisition System (DAQ) developed for the TAWARA_RTM project (TAp Water RAdioactivity Real Time Monitor). The aim is detecting the presence of radioactive contaminants in drinking water; in order to prevent deliberate or accidental threats. Employing a set of detectors, it is possible to detect alpha, beta and gamma radiations, from emitters dissolved in water. The Sensor Network (SN) consists of several heterogeneous nodes controlled by a centralized server. The SN cyber-security is guaranteed in order to protect it from external intrusions and malicious acts. The nodes were installed in different locations, along the water treatment processes, in the waterworks plant supplying the aqueduct of Warsaw, Poland. Embedded computers control the simpler nodes, and are directly connected to the SN. Local-PCs (LPCs) control the more complex nodes that consist signal digitizers acquiring data from several detectors. The DAQ in the LPC is split in several processes communicating with sockets in a local sub-network. Each process is dedicated to a very simple task (e.g. data acquisition, data analysis, hydraulics management) in order to have a flexible and fault-tolerant system. The main SN and the local DAQ networks are separated by data routers to ensure the cyber-security.

© 2017 The Authors. Published by Elsevier B.V. This is an open access article under the CC BY-NC-ND license

(<http://creativecommons.org/licenses/by-nc-nd/4.0/>).

Peer-review under responsibility of the Scientific Committee of the Conference on the Application of Accelerators in Research and Industry

* Corresponding author. Tel.: +49-049-827-5934.

E-mail address: cristiano.fontana@pd.infn.it

Keywords: water safety; distributed systems; data acquisition; real-time monitor; online analysis.

1. Introduction

Safe tap water is of paramount importance in our modern society. Recently, water plants have become sensitive sites that have to be protected against terroristic attacks or accidental disasters. Among the potential threats that can target the distribution of drinking water, there is the radiological contamination. Such contamination could be deliberate, in the case of a terroristic attack, or accidental, in the case of accidents in nuclear power plants or waste disposal sites. The demand for fast and reliable methods for tap water monitoring has been increasing. The aim of the TAWARA_RTM project is controlling the quality of drinking water, in terms of radiological contamination. The presence of radioactive contaminants in drinking water is monitored and recorded in real-time; in order to prevent deliberate or accidental threats. In this context, the goal of the TAWARA Real Time Monitor (RTM) system is the measurement of the gross alpha/beta activity using scintillation detectors submerged in the water. The platform developed for the project provides real-time measurements, data storage and interfaces with the water plants infrastructures. The TAWARA_RTM prototype was installed at the Northern Water Treatment Plant of the Warsaw Waterworks Company (MPWiK).

Liquid Scintillation Counting (LSC) has been a technique widely used in environmental applications (Forte *et al.*, 2002). Water samples are mixed with scintillators and the resulting cocktails are very effective in determining gross beta and alpha activity as well as in deriving spectral information. On the other hand, this is an off-line technique, as the samples have to be carried to laboratories for preparation and analysis. Several hours could pass between the sample collection and the actual measurements. Moreover, the treated samples have to be properly disposed of. For all these reasons LSC is not suitable for a real-time monitoring apparatus. Plastic scintillators have also been investigated as an alternative (Ifergana *et al.*, 2015), for detecting beta particles in liquid samples. Another explored possibility is to use a sandwich type scintillation detector, made up of a layer of ZnS(Ag) and a plastic detector to collect alpha and beta counts at the same time (Ifergana *et al.*, 2015). Advantages of these methods are the easier experimental set-up and maintenance. However, it is harder to distinguish between alpha and beta signals due to a higher background.

As part of TAWARA_RTM project commercial plastic scintillators were employed for the measurement of the radioactivity in water (Bodewits *et al.*, 2016). We selected the EJ-444 (eljentechnology.com) scintillator that is composed by a thin layer of ZnS(Ag) phosphors on a fast plastic scintillator. Alpha particles are detected in the ZnS(Ag) layer, whereas beta are detected inside the plastic layer. The difference in the decay times of the two scintillation signals allows the separation the two types of particles by Pulse Shape Discrimination (PSD).

2. The TAWARA_RTM platform concept

The TAWARA_RTM platform is installed along the normal treatment of the tap water, in the waterworks plant supplying the aqueduct of Warsaw, Poland, as shown on Fig. 1. At the raw water intake an Early Alarm Detector (EAD) monitors the water at the very first stage of treatment. It is meant to generate an alarm in the case of a sudden and large contamination with water containing gamma-radiation sources. With this early monitoring, the whole water treatment plant can be quickly stopped in order to avoid a severe contamination of the equipment. Several time-spans of analysis are foreseen (see section 6) for progressively smaller contamination events over larger time scales. After the ordinary water treatment, a Real-Time Monitor (RTM) is installed for smaller contaminations that were not filtered by the treatment nor detected by the EAD. The RTM is able to precisely measure both alpha and beta-emitting contaminants to monitor the public tap water safety. As for the EAD, several time-spans of analysis are foreseen. In the case of an alarm, samples of the water can be analyzed with a higher resolution spectroscopic system. All the information produced by the infrastructure is continuously stored in the local databases of the nodes and in a central database. The information is presented also to the waterworks operators; who are trained to handle the possible scenarios and emergencies and communicate with the civil security authorities.

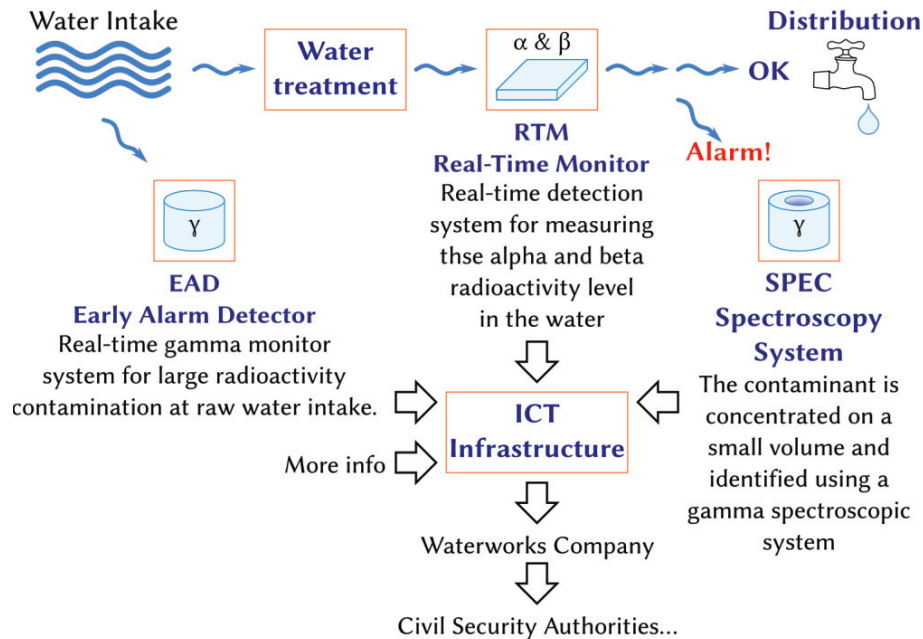

Fig. 1. Diagram of the TAWARA_RTМ concept, the water flow is shown with blue wiggly lines, the information flow is shown with white arrows. The main components of the system are described. The normal water flow passes through the standard water treatment facility. At the intake part of the water is analyzed with the Early Alarm Detector. After the treatment the Real-Time Monitors analyze the clean water. If there is an alarm the distribution is stopped, and the water is analyzed with a spectroscopic system.

3. Information and Communication Technology (ICT) infrastructure

The 3. Information and Communication Technology (ICT) infrastructure enables communication between all nodes (*e.g.* EAD(s), RTM(s)...) and the Central Server (CS) (as seen in Fig. 2). It hides the complexity of the internal architecture and provides a secure way of communication. Every node is connected on a distributed Sensor Network (SN), as they are installed in remote places. The cyber-security is guaranteed by isolating the nodes in a Virtual Private Network (VPN). VPNs are professionally developed systems that isolate and protect sub-networks that are spread over insecure connections. This approach prevents external intrusions and malicious acts. The architecture is layered on several modules that handle the different tasks (such as data acquisition, analysis, communication and user interface). The layers are implemented on distinct devices to spread the processing load. All the nodes are managed by Data Collection Communication (DCC) modules, which are robust embedded computers that isolate the local node inside the VPN. Each DCC has a local database that is periodically synchronized with the global database in the CS. The simpler nodes are constituted only by a DCC connected to the sensors. The more complex nodes have a Local-PC (LPC) that handles the data acquisition and analysis. All the user interfaces are implemented as local web pages, in order to simplify the interoperability. The data acquisition systems hosted in the nodes are called Software for Control and Analysis (SCA, see section 4).

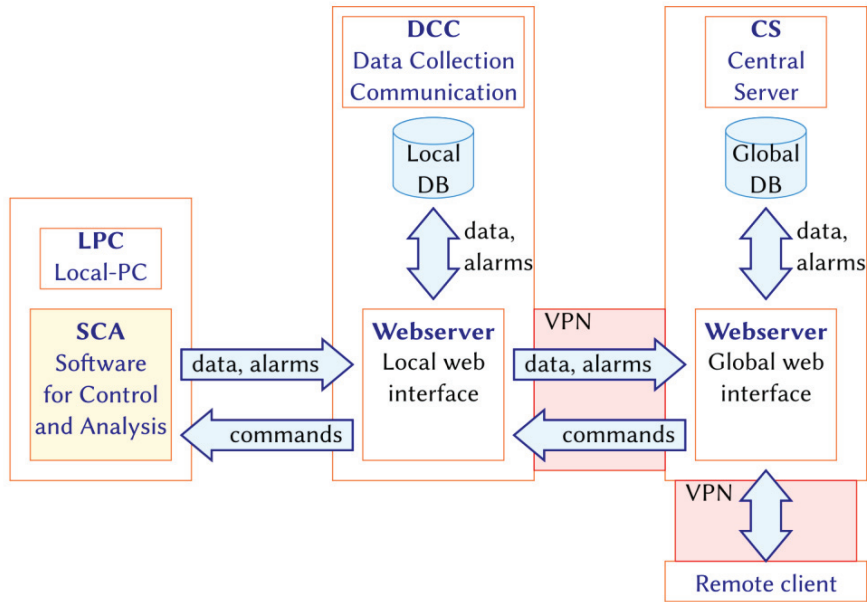

Fig. 2. Schematic diagram of the Internet and Communication Technology (ICT) infrastructure.

4. Software for Control and Analysis (SCA) data acquisition system

The Software for Control and Analysis (SCA) is implemented as subnetworks of processes that are sandboxed inside each node. The DCCs isolate the SCA subnets from the main network (Fig. 3). The Data Acquisition systems (DAQ) are split over different processes, also called servers, that carry out simple tasks and communicate through network sockets. Such architecture allowed an easier and agile development phase. Being dedicated only to simple tasks, the servers were easier to develop and debug. The servers are designed following the states machine paradigm. The processes are isolated from each other by the communication sockets. If one of the servers stops, the whole network is not stopped and can continue to work. This flexibility allowed the developers to stop, update and restart the single processes in the running SCA, without compromising the overall functionality. Only two servers are in charge of the interface with the main network: a commands receiver that listens for commands received from the main network and user interfaces, and a data router that collects the data from the SCA subnet and sends it to the DCC and the local database. This isolation is in place to ensure the cyber-security.

In the SCA subnet, the DAQ manager is the controller of all the servers in the subnet. It controls the start-up procedure of the node's DAQ which can be a non-trivial task. It monitors the activity of the other servers and, in case of problems, it is able to stop and restart the single processes. Periodically it can trigger check-up procedures of the node. The data proxy collects all the data from the separate processes, and forwards them to the data router and manager. Such a proxy was implemented to simplify the data streams management as they are all collected in one stream that is easier to read.

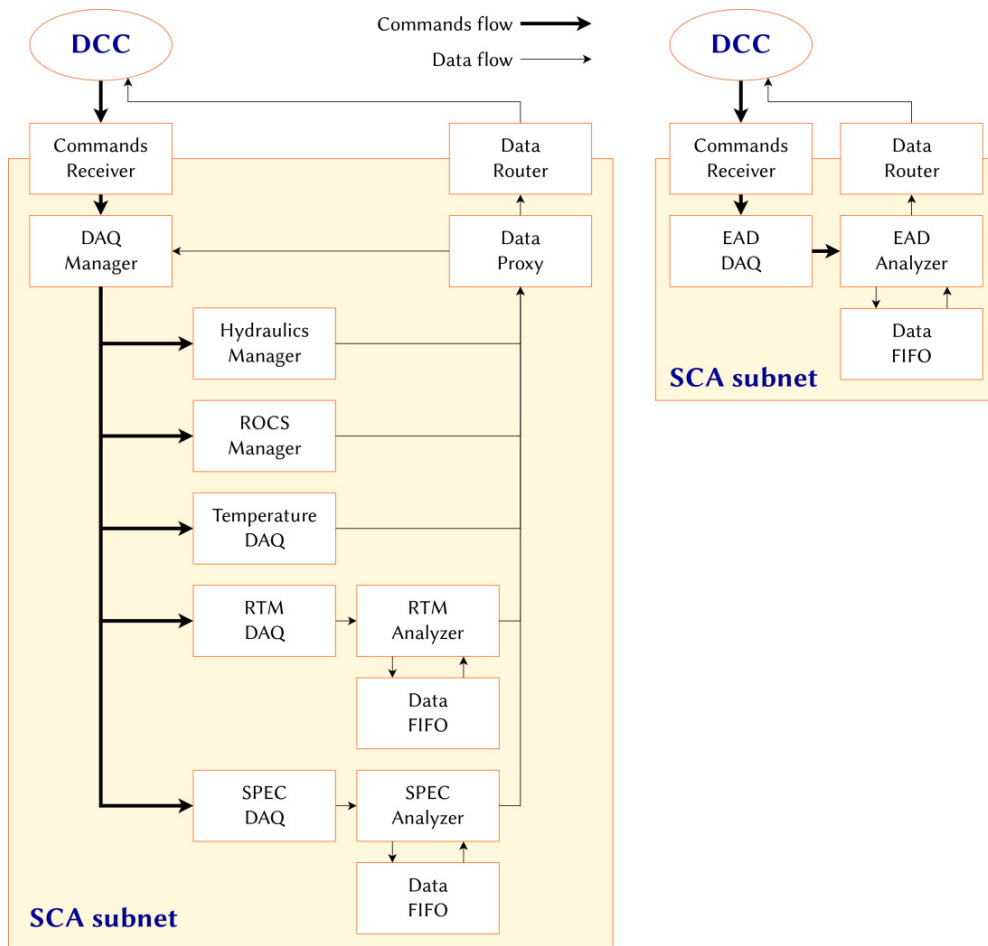

Fig. 3 Example diagrams of the Software for Control and Analysis (SCA). The SCAs are constituted by sub-networks of different processes that are in charge of only a simple task.

4.1. DAQ servers

Fig. 4 (a) shows an example of a DAQ server's state machine. When the process is started, it creates and connects the sockets for communication and then it sets-up the hardware to enable the acquisition. When the main loop is entered, the data is continuously read from the detectors and saved in a buffer. When the buffer is full, or a timeout occurs, the data is broadcast to the SCA data proxy (Fig. 3) or any other client.

4.2. Data analyzers

Fig. 4 (b) shows an example of a data analyzer's state machine. When the process is started, it creates and connects the sockets for communication and enters in the main loop. Data is continuously read from a socket and stored in a First-In First-Out (FIFO) data structure. When a timeout occurs, the data is recollected from the FIFO and analyzed; the result is broadcast to the SCA data proxy (Fig. 3) or any other client.

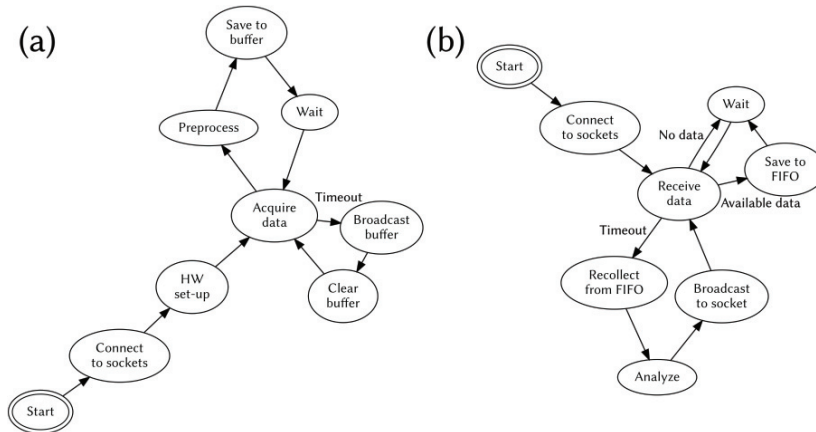

Fig. 4. (a) DAQ server's state machine. (b) Data analyzer's state machine.

5. Data FIFO

Acquisition time spans are of the order of months, and the system had to be completely automatic. The need of a continuous analysis of the acquired data required the development of a new dynamic data storage. The structure follows the principle of a First-In First-Out (FIFO) queue, so data is stored in the order that is acquired and can be read in the same order. The structure is versatile, as it can store generic data with an associated timestamp. The interface of the data FIFO allows the extraction of a dataset of a specified time interval and to execute a given routine over it. The temporal evolution of the system is monitored by moving the time windows. An expiration time can be set in order to control the memory footprint and discard old data. The data FIFO can be completely saved and recovered to/from long-term storage media.

6. Analysis procedure

An automatic analysis procedure was developed to have a fully autonomous system. The detectors' counting rate was assumed to follow Poisson statistics. The analysis monitors the counting rate and looks for increases that are not compatible with the Poisson statistics, given a certain confidence level. Three layers of analysis were developed, with three different time intervals for detecting different levels of contamination: a) a fast analysis, for quick and sudden increases of activity due to major accidents or attacks; b) a medium analysis; c) a slow analysis, for slow increases due to small leaks of radioactivity over long periods of time. To estimate the current counting rate a "background" dataset is extracted from the FIFO, with a long time span (compared to the analysis period) that was prior to the current measurement (Fig. 5). The current counting rate is calculated on a "signal" dataset, extracting from the FIFO the dataset of the period immediately before the current time (Fig. 5). The average counting rate from the background is then compared to the current counting rate. A threshold is dynamically calculated (Fig. 6) with the background counting rate in order to have a specific false alarm rate. If the current counting rate passes that threshold an alarm is triggered.

To verify the hypothesis of the Poissonian statistics of the counts, the distribution of the pull was analyzed. The pull is defined according to the following equation (Demortier *et al.*, 2002):

$$g = \frac{y_{\text{sgn}} - y_{\text{bkg}}}{\sqrt{\sigma_{\text{sgn}}^2 - \sigma_{\text{bkg}}^2}}$$

where y_i represent the counting rates and σ_i the associated standard deviations. Having a dynamic system, the estimate of the counting rate, from the background, was employed as the predicted value of the current counting rate.

The pull distribution should have zero mean and unitary width. The obtained experimental pull distribution is in very good agreement with the theoretical prediction, with a mean of -0.02 ± 0.01 and a standard deviation of 1.01 ± 0.01 .

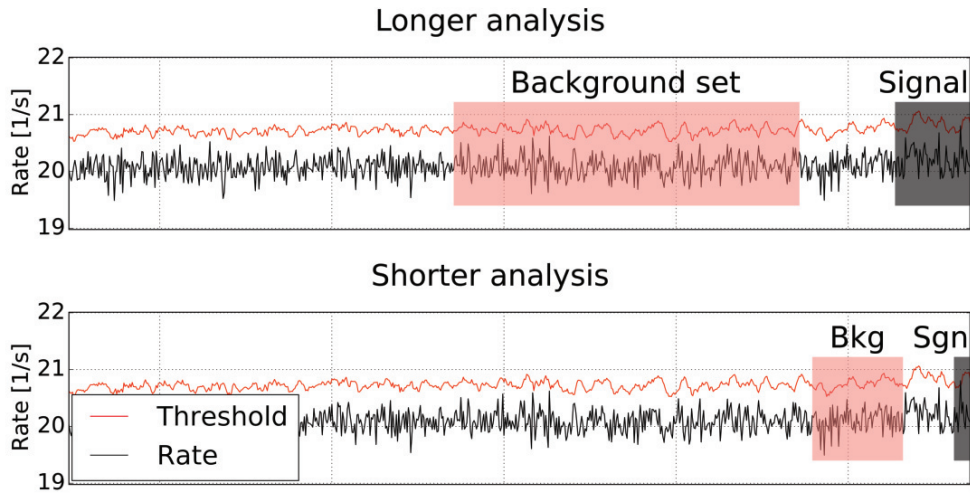

Fig. 5. Examples of analysis time windows, for analyses of different time-spans.

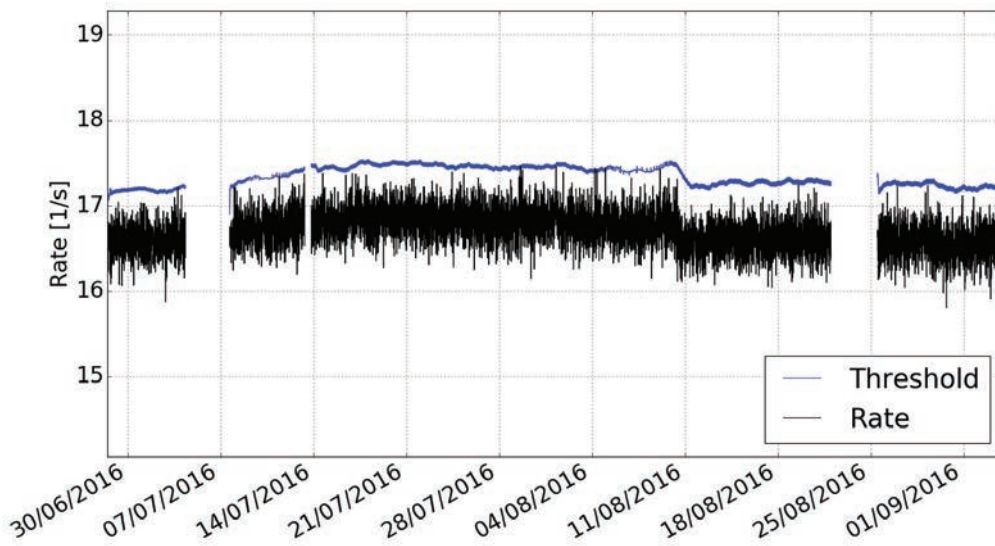

Fig. 6. Example of counting rates and the dynamically calculated threshold over a period of two months.

7. Dynamic calibration monitor

Since operation time is of the order of months, the detectors gain was continuously monitored. Gain shifts on such long periods of time were easily seen in the experimental set-up. Long-scale gain shifts are still under investigation

while short-scale gain shifts were probably be due to variations in the ambient temperature (Fig. 7 **Error! Reference source not found.**). The analysis processes continuously detect the centroid of the natural-occurring ^{40}K peak (1461 keV), in the energy spectra. The data are then dynamically calibrated with that peak's centroid, to ensure a very good stability. As a safety check, the ^{40}K peak is then determined again in the calibrated spectrum and compared to the nominal value. The system showed that the oscillations of the calibrated peak were negligible compared to the peak resolution.

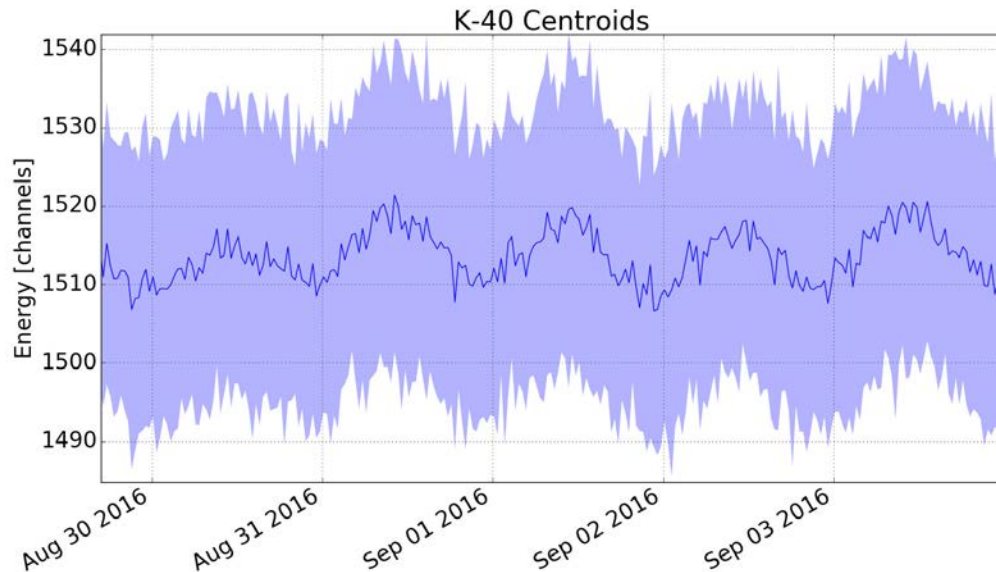

Fig. 7. Daily oscillations in the uncalibrated spectrum of the 1461 keV peak, of the naturally occurring ^{40}K .

8. Conclusions

The experience with the distributed networks of the SCAs enabled a very agile development of the distributed data acquisition system. The distributed nature of the architecture allowed the developers to create software with different kinds of programming languages, using the best option for each task. When the system was deployed, it was possible to remotely debug and update the single processes without compromising the whole system. Each of the DAQ managers has been verified to autonomously handle unexpected stops, both in the hardware and software. With the first prototype, data was acquired for a period of several months, with a very good uptime. The acquired data was used to verify the assumptions about the statistics of the counting rates. Moreover, the dynamic calibration of the system proved to be effective and the online analysis allowed a very quick response to the inputs of the system.

References

- Bodewits, E., Cester, D., Lunardon, M., Moretto, S., Schotanus, P., Stevanato, L. and Viesti, G., IEEE Transactions on Nuclear Science, Vol 63, Issue 3 (2016) "Characterization of a Large Area ZnS(Ag) Detector for Gross Alpha and Beta Activity Measurements in Tap Water Plants" doi: 10.1109/TNS.2015.2495207.
- L. Demortier, and L. Lyons, CDF Note 43 (2002) "Everything you always wanted to know about pulls"
- M. Forte, R. Rusconi, M.T. Cazzaniga, and G. Sgorbati, Microchemical Journal, Volume 85, Issue 1 (2007) "The measurement of radioactivity in Italian drinking waters" doi:10.1016/j.microc.2006.03.004.
<http://www.eljentechnology.com/products/zinc-sulfide-coated/ej-444>
- Y. Ifergana et al., Nucl. Instr. Meth. Phys. Res. A 784, (2015) 93–96 "Utilization of wavelength-shifting fibers coupled to ZnS(Ag) and plastic scintillator for simultaneous detection of alpha/beta particles" doi:10.1016/j.nima.2014.11.049