

## Cornell University School of Hotel Administration The Scholarly Commons

---

Articles and Chapters

School of Hotel Administration Collection

---

2011

# Customer Experience in Online Financial Services: A Study of Behavioral Intentions for Techno-Ready Market Segments

Xin David Ding  
*University of Houston*

Yang Huang  
*University of Houston*

Rohit Verma  
*Cornell University, rv54@cornell.edu*

Follow this and additional works at: <http://scholarship.sha.cornell.edu/articles>

 Part of the [E-Commerce Commons](#), [Finance and Financial Management Commons](#), [Marketing Commons](#), and the [Portfolio and Security Analysis Commons](#)

---

### Recommended Citation

Ding, X. D., Huang, Y., & Verma, R. (2011). *Customer experience in online financial services: A study of behavioral intentions for techno-ready market segments*[Electronic version]. Retrieved [insert date], from Cornell University, School of Hotel Administration site: <http://scholarship.sha.cornell.edu/articles/520>

This Article or Chapter is brought to you for free and open access by the School of Hotel Administration Collection at The Scholarly Commons. It has been accepted for inclusion in Articles and Chapters by an authorized administrator of The Scholarly Commons. For more information, please contact [hlmdigital@cornell.edu](mailto:hlmdigital@cornell.edu).

---

# Customer Experience in Online Financial Services: A Study of Behavioral Intentions for Techno-Ready Market Segments

## **Abstract**

**Purpose** – Drawing upon research in consumer behavior, the purpose of this paper is to deploy an alternative way to predict behavioral intention with customer technology beliefs and experience in e-brokerage services.

**Design/methodology/approach** – This study tests the proposed framework and relevant hypotheses with survey responses collected from 258 online investors.

**Findings** – Technology-ready (TR) customer segments vary in their evaluations of customer-service interfaces; interface evaluations affect cognitive service experience; and interface evaluations and cognitive experience affect customers' behavioral intentions.

**Research limitations/implications** – This study indicates that flow experience emerges as an important factor for achieving sustainable competitive advantages in e-brokerage services. The research findings and relevant hypotheses might not apply to low-credence services.

**Practical implications** – The findings indicate that service designers need to examine the life cycle of the intended service offerings and customize corresponding service/product features based on customers' technology beliefs and personal characteristics, which can further lead to maximized flow experience and increased intention rate.

**Originality/value** – The paper is among the first attempts to examine how psychographic features affect customers' experience and valuation of certain service system interfaces from service design perspective.

## **Keywords**

service design, technology belief, e-brokerage, experience, surveys, stocks and shares, internet, consumer behaviour

## **Disciplines**

E-Commerce | Finance and Financial Management | Marketing | Portfolio and Security Analysis

## **Comments**

### **Required Publisher Statement**

© Emerald. Final version published as: Ding, X. D., Huang, Y., & Verma, R. (2011). Customer experience in online financial services: A study of behavioral intentions for techno-ready market segments. *Journal of Service Management*, 22(3), 344-366. Reprinted with permission. All rights reserved.

# Customer Experience in Online Financial Services: A Study of Behavioral Intentions for Techno-ready Market Segments

Xin David Ding

*Department of Information and Logistics Technology, University of Houston,  
Houston, Texas, USA*

Yang Huang

*Department of Finance, University of Houston, Houston, Texas, USA, and*

Rohit Verma

*School of Hotel Administration, Cornell University, Ithaca, New York, USA*

**Purpose** – Drawing upon research in consumer behavior, the purpose of this paper is to deploy an alternative way to predict behavioral intention with customer technology beliefs and experience in e-brokerage services.

**Design/methodology/approach** – This study tests the proposed framework and relevant hypotheses with survey responses collected from 258 online investors.

**Findings** – Technology-ready (TR) customer segments vary in their evaluations of customer-service interfaces; interface evaluations affect cognitive service experience; and interface evaluations and cognitive experience affect customers' behavioral intentions.

**Research limitations/implications** – This study indicates that flow experience emerges as an important factor for achieving sustainable competitive advantages in e-brokerage services. The research findings and relevant hypotheses might not apply to low-credence services.

**Practical implications** – The findings indicate that service designers need to examine the life cycle of the intended service offerings and customize corresponding service/product features based on customers' technology beliefs and personal characteristics, which can further lead to maximized flow experience and increased intention rate.

**Originality/value** – The paper is among the first attempts to examine how psychographic features affect customers' experience and valuation of certain service system interfaces from service design perspective.

**Keywords** Service design, Technology belief, E-brokerage, Experience, Surveys, Stocks and shares, Internet, Consumer behaviour

**Paper type** Research paper

## Introduction

As the internet unfolded and the online business started to emerge, many bricks-and-mortar service firms move to having an online presence. While the internet offers significant potential as a low-cost retail distribution channel, it is a dangerous territory (Reibstein, 2002). On the one hand, technology has become prominent within the firm-customer relationship and dramatically changed how services are conceived and delivered (Bitner and Brown, 2006). On the other hand, the uncertainty stemming from the evolving and technology-driven customer-service interactions leaves firms grappling with how best to leverage their strategies (Porter, 2001).

Among all service sectors, the brokerage industry has been quite successful in attracting customers to its online presence. While online retail sales represented barely 5 percent of overall retail sales in 2006, online stock trading accounted for nearly 40 percent of all retail investment transactions with over four trillion assets administered by 34.1 million e-brokerage accounts (Anderson, 2007). To survive the fierce competition in e-brokerage market, most market players undertake two alternative strategies: established brokers strive to reduce transaction costs and improve service quality by delivering service through the internet, whereas emerging e-brokers compete through deep discounts, such as service fees of less than \$5. Although commission fees influence investors' initial choices (Ding et al., 2007), such fees alone might not retain customers in a long run (Reibstein, 2002). Instead, existing e-commerce literature suggests that identifying and structuring the "voice of the customer" by understanding customer beliefs can substantially boost service performance such as customer satisfaction and word-of-mouth branding (Chen and Hitt, 2003; Novak et al., 2000).

While anticipating and responding to customers' evolving beliefs is critical to firms' strategic positioning and performance (Menor and Roth, 2008), some researchers suggest that there is an industry-wide missing link between what customers may require and what service organizations intend to provide (Johnston and Clark, 2001; Goldstein et al., 2002). Alternatively, other researchers suggest service firms to integrate customer beliefs and value and organizations' strategic intents in the service design process (Gupta et al., 2004; Bitner and Brown, 2006). Tactically, organizations should deliberately choose a set of encounters to deliver a unique experience (DeLone and McLean, 2003; Berry et al., 2006). Strategically, organizations need to consider partnerships with customers and build long-term firm-customer relationships (Goldstein et al., 2002; Auh et al., 2007).

Extant studies have looked at whether certain service system interface (e.g. customer service, product offerings, and financial statements) positively influence service quality and customer satisfaction (Krishnan et al., 1999). However, less attention has been paid to customer beliefs and experience associated with e-brokerage services. This lack of attention in the literature is significant because a firm's long-term shareholder value is not only influenced by what it offers, but also by whether such offerings reflect customer beliefs and facilitate a positive customer experience (Novak et al., 2000; Reibstein, 2002). Specifically, customer

experience is an important intangible asset because it fully captures a customer's interactions with certain service system and therefore is difficult to imitate and provides sustainable competitive advantage from a resource-based view perspective (Ding et al., 2010; Roth and Menor, 2003; Newbert, 2007).

In response to the call for examining customer experience on the basis of experience design, delivery, and performance measurement (Roth and Menor, 2003), we provide a framework to evaluate firm performance in terms of firm-customer relationship for e-brokerage services. Our framework entails two levels of analysis based on customers' feedback. In the first level, we assess how customers' technology beliefs, as measured by technology readiness (TR) (Parasuraman, 2000) influences their experience of and behavioral intention for e-brokerage services. In the second level, we examine how customer experience with certain service system interfaces affects firm-customer relationship. Together, our integrated analysis enables firms to understand what drives overall firm-customer relationship, how the effects vary across customer segments, and what firms could do to specifically fine-tune these drivers of firm-customer relationship and thus improve their performance.

Our research framework is among the first in service research to theorize that technology beliefs, service system interfaces, and customer experience all affect firm-customer relationship both independently and in tandem. Considering that 1 percent improvement in retention cost improves firm value by 5 percent (Gupta et al., 2004), our research not only extends traditional service design studies by drawing much needed attention to customer experience, but also offers practitioners a strategic level, i.e. engaging in strategic service planning methods such as service blueprinting to fine-tune the design of service encounters to facilitate positive customer experiences and to "lock-in" customers.

In what follows, we first review existing literature for technology readiness, service system interfaces, and customer experience management. Next, we develop a framework to integrate all the vital pieces of service design and experience management with customer behavioral intention. We test the proposed framework and relevant hypotheses with survey responses collected from online investors. We then analyze and discuss the managerial and research implications of the model and experimental results. In addition, we offer suggestions for future research.

### **Theoretical background**

Compared with traditional service systems in which customers wait to be served, customer-firm relationships in e-service undermine substantial transformation. Because of technology's expanding role in service delivery, customers nowadays have evolved from an integral part of service processes (Langeard et al., 1981) to partial employees (Mills et al., 1983) and service co-producers (Etgar, 2008). Although the shift from passive audience to active co-creators leads to favorable assessments and positive behavioral intentions in general (Pralhad and Ramaswamy, 2000; Auh et al., 2007), individuals with different psychographic profiles

might react to technology-based services differently (Massey et al., 2007; Parasuraman, 2000). Studying psychographic typologies provide insights into individual value and motivations, which offer a more complete profile of a potential market (Parasuraman, 2000; Tsikriktsis, 2004). Our study also sheds lights on the debate over human issues in service design by moving away from the long-fought battle for universally positive or negative performance impact of technology and usability evaluation toward a finer-grained quest for when some firms can derive more satisfied customers from experience design and target marketing (Chase and Dasu, 2001; Cook et al., 2002).

### Technology readiness

Drawing on recent research in customer behavior concerning consumer beliefs about technology, we use TR, a multidimensional construct to measure psychographics and beliefs in technology-based service (Massey et al., 2007; Parasuraman, 2000). According to Parasuraman and Colby (2001), TR refers to people's propensity to embrace and use technologies and consists of four major components measuring various technology beliefs. The first two components of optimism and innovativeness are contributors that increase an individual's TR. The other two components of discomfort and insecurity are inhibitors that suppress an individual's TR. In general, optimism is a positive view of technology and a belief that offers people increased control, flexibility, and efficiency in their lives. Innovativeness is a tendency to be a technology pioneer and thought leader, which measures the extent to which an individual believes that he or she is at the forefront of trying out new technology-based products/services. Next, discomfort refers to a perceived lack of control over technology and a feeling of being overwhelmed by it, which presents the extent to which people have a general paranoia towards technology-based products and services. Finally, insecurity is a distrust of technology and skepticism about its ability to work properly (Parasuraman and Colby, 2001).

Based on the various combinations of both positive and negative beliefs regarding technology, customers can be segmented into five groups of explorers, pioneers, skeptics, paranoids, and laggards, which play distinct roles in moving a new technology-based product to maturity (Parasuraman and Colby, 2001). Recent research showed that the TR typology can be further extended to access final usage, usability needs and evaluations (Taylor et al., 2002; Tsikriktsis, 2004; Massey et al., 2007). Specifically, TR typology provides a framework for technology adoption (Taylor et al., 2002) and usability evaluation (Massey et al., 2007); it also explains the difference in current usage and future intention to use technology-based service (Tsikriktsis, 2004). However, it is unclear how the typology influences the evaluation of service system interfaces and the customer-firm relationship. Specifically, should we expect that motivated and fearless customers (e.g. explorers) enjoy technology-based service system and therefore hold a positive experience towards the system interfaces and tend to use more, while unmotivated and inhibited customers (e.g. laggards) dislike the service system interfaces and tend to use less? Studying the relationship between TR typology and service system

performance can help service organizations alike to customize service package and interfaces for targeted customer segments.

### Service System Interfaces

Service system interfaces such as information- and system-related characteristics (Bailey and Pearson, 1983; Doll et al., 1995; Wixom and Todd, 2005), service quality attributes (Anderson and Sullivan, 1993; Parasuraman et al., 2005), and product offerings (Krishnan et al., 1999; Pullman and Gross, 2004) have been extensively studied in prior research. Collectively, the set of interfaces can be categorized as functional, mechanic, and humanic clues embedded in customers' experiences with the service delivery system (Berry et al., 2006). Functional clues indicate technical quality and the reliability and functionality of the offerings; mechanical clues provide a physical representation of the intangible service; humanic clues refer to the service provider's behavior or appearance, such as tone of voice, level of enthusiasm, body language, neatness, and appropriate dress (Berry et al., 2006).

The customer service element of e-brokerage services provides a key determinant of customer intentions and behavior, and corresponds to humanic clues (Parasuraman et al., 2005). The collective findings from prior studies point to several important customer service quality characteristics that include service representatives' knowledge, responsiveness, courtesy, and ease of access (Parasuraman et al., 2005). The process element pertains to functional clues and encompasses ease of use and usefulness, which both drive customer satisfaction and behavioral intention (DeLone and McLean, 2003; Wixom and Todd, 2005). Important process features include the design, functionality, availability, and reliability of the service process (DeLone and McLean, 2003; Parasuraman et al., 2005). Finally, product variety influences service performance and resembles mechanic clues (Krishnan et al., 1999). In the context of e-brokerage services, product variety includes the variety of financial products, research tools, and the amount of leverage the provider offers, such as the interest rate charged for borrowing.

The aggregate, cumulative perception of specific service system interfaces from interacting with the clues lead customers into a cognitive flow experience state, which stimulate further behavioral intention (Carbone and Haeckel, 1994; Ding et al., 2010). The connection between clues and flow experience has been echoed in earlier studies – experiences are created when a provider intentionally uses services as the stage, and goods as props, to engage customers in a way that creates a memorable event (Pine and Gilmore, 1998), or when customers have sensations or knowledge acquisition through their interaction with different elements of a context purposefully designed by a provider (Gupta and Vajie, 1999).

### Flow Experience

Technology, especially the technology in human-computer interaction, is deeply embedded in user experience. According to McCarthy and Wright (2004), there is a new way of seeing experience with technology – as creative, open, relational, and as participating in felt

experience. Despite the widely accepted notion of experience management, experience design originated and has been studied almost exclusively in entertainment and hospitality businesses. Although the “autotelic experience” or flow experience underlies virtually every aspect of the consumer’s interaction with firms and their offerings, investigations on how actual flow experience affects customer behavioral intention have been sparse (Csikszentmihalyi, 1991).

The goal of experience design is to create a compelling experience, which can be measured and analyzed on the basis of flow experience (Csikszentmihalyi, 2000). Similar to many context-based experiences, flow experience affects customer satisfaction and future behaviors. Csikszentmihalyi (2000) shows that flow experience exists in various service contexts and suggests that an optimum state of flow, or “autotelic experience,” occurs when:

- a clear set of goals requires an appropriate response;
- feedback is immediate; and
- a person’s skills are fully involved in overcoming a significant but manageable challenge.

Ghani and Deshpande (1994) analyze autotelic experiences and argue that flow depends on a customer’s sense of control and the level of challenges associated with using a system or the services it supports.

Past research has examined the cognitive states of flow construct in human-computer interaction and shown that flow can be determined by focused attention, interactivity, sense of control, level of challenges, and skills (Ghani and Deshpande, 1994; Huffman et al., 1996; Novak et al., 2000). As e-brokerage services exhibit credence characteristics (Ding et al., 2007), the complex nature of the information exchanges in the service context is best captured with the level of focused attention and interactivity (Brush and Artz, 1999; Lovelock, 2001). Among all the cognitive states, focused attention refers to a “centering of attention on a limited stimulus field”, whereas interactivity refers to the speed and the mapping of the interaction (Novak et al., 2000). While customers occasionally seek assistance from service representatives, their major interaction for service transaction (e.g. stock trading) is through their primary e-brokerage accounts. Therefore, the manifold service obtained through multiple channels should foster a positive service experience measured by interactivity and focused attention with the e-brokerage account (Ding et al., 2010).

### *Behavioral Intention*

Compared with traditional brick and mortar business, e-brokerage firms are less likely to achieve long-term profitability due to low entry barriers, low switching cost, and limited differentiation (Chen and Hitt, 2003). As a result, it becomes critical for e-brokerage firms to understand the determinants of customer retention and consequently manage its retention ability (Pine and Gilmore, 1998). The construct of behavioral intention derives from the theory of reasoned action (TRA) literature (Fishbein and Ajzen, 1975), which suggests external variables such as personal values or beliefs about the broader work environment should



directly affect beliefs that lead to specific intentions. Positive behavioral intentions are reflected in the service providers' ability to keep its customers to remain loyal, pay price premium, and spread positive word-of-mouth (Zeithaml et al., 1996). Much of the work in TRA has focused on two key beliefs as the determinant of behavioral intention – perceived usefulness and ease of use (Massey et al., 2007), yet limited research examined how technology beliefs affect intention to use technology-based services (Curran et al., 2003; Ding et al., 2007). In addition, behavioral intention might also relate to customers' interaction and experience with service system interfaces (Krishnan et al., 1999; DeLone and McLean, 2003). In our research, we measure behavioral intention as the likelihood for e-brokerage consumers to spread positive-word-of-mouth and remain loyal (Zeithaml et al., 1996).

### **Hypotheses**

We propose a general model describing the interconnections among TR, service system interfaces, flow experience, and behavioral intention with corresponding hypotheses. The first part of the model suggests that TR segments will differ in user evaluation of service system interfaces, experience, and behavioral intention; the second phase of the model suggests that the performance of specific service system interfaces will influence the level of flow experience generated in a particular service setting. The last phase of the model suggests that flow experience will mediate behavioral intention. That is, service system interfaces can both directly and indirectly (through flow experience) influence behavioral intention.

#### *TR vs Service System Interfaces, Flow Experience, and Behavioral Intention*

The first set of hypotheses address the relationships between TR typology and service system interfaces/flow experience/behavioral intention. Previous research in TR has found support for connection between TR typology and technology adoption (Taylor et al., 2002) or usability evaluation (Massey et al., 2007). Past research has not examined how TR typology affects evaluations of specific service system interfaces and customer experience, but the TRA literature supports that personal beliefs about the broader work environment should directly affect further beliefs that lead to specific intentions (Fishbein and Ajzen, 1975). Therefore, we hypothesize that:

*H1a.* TR segments differ in evaluations of specific service system interfaces.

*H1b.* TR segments differ in their flow experiences.

*H1c.* TR segments differ in their behavioral intentions.

#### *Service System Interfaces and Flow Experience*

Experiences are created when a provider intentionally uses services as the stage, and goods as props, to engage customers in a way that creates a memorable event (Pine and Gilmore, 1998) or when customers have sensations or knowledge acquisition through their interaction with different elements of an interface purposefully designed by a provider (Gupta

and Vajie, 1999). Chase and Dasu (2001) indicate that the use of behavioral science is enhancing customer experience. Similarly, Berry et al. (2006) suggest engineering customer experience by managing the clues embedded in customers' experiences with service system interfaces that trigger their emotions. Very little research investigated how specific service system interfaces elicit positive cognitive experience (Ding et al., 2010; Pullman and Gross, 2004).

We adapt the experience clues concept (Berry et al., 2006) and flow experience construct (Novak et al., 2000) in our research framework and examine the relationships between service system interfaces (service quality, process feature, and product variety) and flow experience (focused attention and interactivity). Prior research indicate that a knowledgeable, courteous, and easy to reach customer representative can reduce customer's anxiety about using e-brokerage service, augment their knowledge base, and therefore help them focus on their investment activities and improve their interaction with the e-brokerage service (Froehle, 2006; Krishnan et al., 1999; Wolfenbarger and Gilly, 2003). In addition, process characteristics including security, reliability, ease of use, availability, response time, and interface affect not only customer retention but also its effectiveness (Chen and Hitt, 2003; DeLone and McLean, 2003). For example, an easy-to-navigate and responsive web site can help customers locate target information, enhance their analysis capabilities, and reduce their choice set, which should increase their focused attention and interactions with the e-brokerage service (Ding et al., 2010; Pavlou and Fygenson, 2006). Finally, e-brokerage providers can attract new customers and retain existing customers by offering a comprehensive array of products, detailed information, and effective analysis tools (Chen and Hitt, 2003). The variety of product offerings can be further customized to match investors' profiles to enhance focused attention and customer-system interaction (Krishnan et al., 1999; Novak et al., 2000).

Thus, we posit the following hypothesis to explore the relationships between service system interfaces and customers actual flow experience:

*H2. The performance of specific service system interfaces is positively related to customer flow experience.*

### *Service System Interfaces, Flow Experience, and Behavioral Intention*

Several empirical researchers have reported significant relationships between flow experiences and service assessments (Csikszentmihalyi, 2000; Novak et al., 2000) or exploratory behaviors (Korzaan, 2003). Other researchers also found empirical evidence on the relationships between service system interfaces and behavioral intention (Wixom and Todd, 2005; Parasuraman et al., 2005; Krishnan et al., 1999; Pullman and Gross, 2004). However, there are limited studies examining flow experience as a mediating variable between service system interfaces and behavioral intention. According to the dual-layer experience model (Ding et al., 2010), the first layer pertaining to service system interfaces affects the next layer of cognitive state of flow experience, which both determine service outcome and exploratory

behaviors (Berry et al., 2006). Thus, we expect flow experience will mediate the relationship between service system interfaces and behavioral intention:

*H3. Cognitive states of flow experience positively mediate the relationships between service system interfaces and behavioral intention.*

### **Research Methodology**

We operationalize and measure relevant constructs using a five-point Likert scale (1 = “strongly disagree”, 5 = “strongly agree”). To examine the relationship between each investigated variables and behavioral intention, we review important variables affecting customers’ web usage, salient measurement scales in previous research, and common metrics frequently used by leading marketing firms. Specifically, we adapt items from Novak et al. (2000) and Korzaan (2003) to measure the flow experience constructs of focused attention and interactivity. We adapt the items for service systems pertaining to service quality from Krishnan et al. (1999) and Froehle (2006); process feature from Nelson et al. (2005); product variety from Balasubramanian et al. (2003); and behavioral intention from Zeithaml et al. (1996). We also employ key metrics suggested by SMARTMONEY, JDPOWER, and KIPLINGER. We follow Churchill’s (1979) recommendations to assess the preliminary instrument in terms of comprehensiveness and clarity. We first examine the instrument’s face validity using a panel of 25 seasoned researchers and experienced online investors. We further conduct a pretest with 35 subjects knowledgeable about online investment to validate and fine-tune our instrument. Suggestions pertaining to the wording of particular items and the questionnaire structure were incorporated into the revised instrument.

We also perform a large-scale pilot study with 230 volunteers familiar with e-brokerage services to examine important psychometric properties. Their responses suggest further refinements of the instrument in terms of purification, reliability, convergent and discriminant validity. We validate the instruments by examining the corrected item-to-total correlations and Cronbach’s alphas; we also examine the internal consistence and discriminant validity by performing two rounds of exploratory factor analysis (EFA) and remove items that exhibit significant cross-loadings (Harman, 1976). The final instrument exhibit satisfactory reliability, convergent validity, and discriminant validity.

### **Sample**

We recruit subjects using the database of a US-based marketing research firm that specializes in online surveys. We randomly select samples from the database consisting of registered participants with prior online stock trading experiences. Of the 2,500 potential respondents, less than 10 percent choose not to participate in the study. Thus, gross non-response bias is not a factor in our study (Flynn et al., 1990). After screening for involvement and incomplete responses, our final sample size is 350, leading to a qualified response rate of 14 percent. The characteristics of the sample demonstrate similar sample statistics with prior online behavior studies (Emmanouilides and Hammond, 2000). We further scrutinize the

responses based on survey duration ( $T_{completion}-T_{Start}$ ), response pattern, and primary service providers. The process retains 258 subjects, whose responses are used in the following analysis and model testing.

### Descriptive Statistics

All respondents traded online through their primary e-brokerage accounts and had certain type of interaction with service representatives in the year of 2007-2008, with 70 percent making more than six trades. 62 percent of the sample is male, and about 55 percent of the subjects are 40-60 years old. 89 percent of the subjects have at least some college education, and 60 percent report a household income of over \$75,000. In addition, 81 percent of the sample report having traded online for more than three years. Among all the subjects, 19.4 percent have their primary online trading accounts with Fidelity, followed by eTrade (15.1 percent), Scottrade (15.1 percent), Charles Schwab (12.4 percent), Ameritrade (12.4 percent), Sharebuilder (8.9 percent), Buy and hold (8 percent), TD Waterhouse (6.2 percent), Merrill Lynch (2.7 percent), Optionsxpress (2.3 percent), Vanguard (1.9 percent), Interactive Broker (1.2 percent), American Express (1.2 percent), Buy and hold (0.8 percent), and Wells Fargo (0.4 percent), and overall, the subjects rate high on optimism (4.11) and innovativeness (3.34) and show less stress in discomfort (2.58) and insecurity (2.74) in online stock trading. In addition, all four dimensions of TR are strongly correlated with each other at  $p < 0.001$  (Table I).

### TR-based Segments

The TR segment membership is identified by applying latent class cluster analysis using Latent Goldw software. Among one to five possible class structures, the five-class solution has the lowest BIC (2305.42) and AIC (2927.20) values, and a second lowest CAIC (2130.42) value, respectively. The entropy R<sup>2</sup> (0.78) and R<sup>2</sup> (0.76) also suggest an acceptable fit of the latent class cluster structure to the data. Combining the latent class cluster solution developed in Latent Gold and the differing belief of technology adoption segments developed by Parasuraman and Colby (2001), we find five distinct segments in our data set: 68 explorers

TR components	Mean	SD	Skewness	Kurtosis	Correlation coefficients <sup>a</sup>			
					OPT	INN	DIS	INS
Optimism (OPT)	4.11	0.61	-0.30	-0.29	1			
Innovativeness (INN)	3.34	0.83	-0.05	-0.27	0.47	1		
Discomfort (DIS)	2.58	0.85	0.45	0.12	0.32	0.32	1	
Insecurity (INS)	2.74	0.78	0.39	0.10	0.25	0.13	0.49	1
Overall TRI	3.57	0.54	0.06	-0.02	0.68	0.69	-0.78	-0.67

Notes: All mean values are on a five-point scale; the overall TRI score for each respondent was obtained by average the scores on the four components (after reverse coding the scores on the discomfort and insecurity components); <sup>a</sup>all correlations are significant at  $p \leq 0.001$

**Table 1.** Summary statistics for the TR index and its components

(26.4 percent), 22 pioneers (8.5 percent), 70 skeptics (27.1 percent), 56 paranoids (21.7 percent), and 42 laggards (16.3 percent). Table II presents the segment variable profile for the five TR segments. We reconfirm the five-segment solution by performing ANOVA tests. Collectively, the results indicate that the four technology beliefs across the TR segments are distinct at  $p$ -value  $\leq 0.001$  levels.

### Measurement Model Analysis and Testing

We first perform a principal component analysis with direct oblimin rotation and a confirmatory factor analysis (CFA) to evaluate our scales (Gerbing and Anderson, 1988). We follow the two-step approach suggested by Gerbing and Anderson (1988) for our measurement model construction and eliminate measured variables or latent factors that do not fit well in initial CFA model. We next perform a separate CFA for each construct to assess whether any structural model exhibits an acceptable goodness-of-fit level. As a result, we remove two measurement items for the process feature construct and one measurement item for the product variety construct that do not load properly. We then fit the structural model to the purified measured variables retained from the first step.

In Table III, we display the estimates of item loadings and cross-loadings for the investigated constructs in an unconstrained analysis. To examine the psychometric properties of the measurement model, we analyze the indicators and constructs for reliability, convergent validity, and discriminant validity. Each investigated construct provides a Cronbach's alpha value and composite reliability greater than 0.70, in support of the satisfactory reliability of our scales (Nunnally, 1978; Fornell and Larcker, 1981).

Segment	Segment variable mean scores (standard deviation)				Segment size
	Contributors Optimism	Innovativeness	Discomfort	Inhibitors Insecurity	
1. Explorers	4.52 <sup>h</sup> (0.45)	3.94 <sup>h</sup> (0.69)	1.91 <sup>l</sup> (0.62)	1.83 <sup>l</sup> (0.45)	68
2. Pioneers	4.46 <sup>h</sup> (0.53)	4.16 <sup>h</sup> (0.61)	3.93 <sup>h</sup> (0.78)	4.17 <sup>h</sup> (0.53)	22
3. Skeptics	3.72 <sup>l</sup> (0.46)	2.84 <sup>l</sup> (0.61)	2.76 <sup>m</sup> (0.56)	2.55 <sup>l</sup> (0.44)	70
4. Paranoids	4.23 <sup>m</sup> (0.44)	3.59 <sup>m</sup> (0.54)	2.04 <sup>l</sup> (0.48)	2.93 <sup>m</sup> (0.46)	56
5. Laggards	3.79 <sup>l</sup> (0.55)	2.44 <sup>l</sup> (0.63)	3.39 <sup>h</sup> (0.61)	3.56 <sup>h</sup> (0.49)	42

Notes: <sup>a</sup>The subscripts of h (high), m (middle), and l (low) refer to the differing technology beliefs across segments (Parasuraman and Colby, 2001); for example, for explorers they are high on contributors of "optimism" and "innovativeness" but low on inhibitors of "discomfort" and "insecurity"

**Table II.** Segment variable profiles

We assess the convergent validity of our scales at both item and construct levels by examining the item loadings and average variance extracted (AVE) (Fornell and Larcker, 1981). An individual item loading greater than 0.7 suggests an indicator shares more variance with the construct it measures than with error variances (Gefen et al., 2000). An AVE greater than 0.50 manifests a construct that shares more variance with its indicators than with error variances

Construct	SL	CR	AVE	Items
Service quality ( $\xi_1$ )	0.84	0.91	0.68	The service representative is responsive
	0.81			The service representative is courteous
	0.84			The service representative solves questions, problems, or concerns in a timely fashion
	0.81			The service representative is easy to reach
	0.82			The service representative is knowledgeable
Product variety ( $\xi_2$ )	0.84	0.78	0.50	The site allows me to trade on a wide range of products
	0.87			The site provides comprehensive research tools
	0.58			The site lets me borrow money at a reasonable rate
	0.61			Cash balance in my account earns interests
Process feature ( $\xi_3$ )	0.73	0.90	0.64	The site is always available
	0.85			The site is easy to navigate
	0.83			The site responds to my requests quickly
	0.82			The site has a friendly interface
	0.77			The site is always reliable
Focused attention ( $\eta_1$ )	0.88	0.94	0.84	While using the trading service, I am completely absorbed in what I am doing
	0.92			While using the trading service, my attention is totally focused
	0.94			While using the trading service, I am concentrated fully
Interactivity ( $\eta_2$ )	0.62	0.81	0.58	Interacting with the site is slow and tedious <sup>a</sup>
	0.88			Pages on the site usually load quickly
	0.85			There is very little waiting time between my actions and the site's responses
Behavioral intention ( $\eta_3$ )	0.83	0.91	0.71	I encourage friends and relatives to do business with the site
	0.88			I say positive things about the site to other people
	0.84			I will do business with the site again in the future
	0.84			I consider the site to be my first choice for online stock trading

**Notes:** SL, standardized loadings; CR, composite reliability; AVE, average variance extracted; items are measured on five-point scales, where 1 represents strongly disagree, 3 is the neutral point, and 5 is strongly agree; <sup>a</sup>reverse-scored item

**Table III.** *Item loadings*

(Fornell and Larker, 1981). As we show in Table III, most items load highly on the constructs they measure with item loadings of 0.7 or greater, except for three indicators. Our measurement items also converge properly on their intended constructs. The items exhibit good convergent validity, as suggested by the AVE greater than 0.50 for each investigated construct.

Finally, we examine discriminant validity by comparing the correlations among constructs and the AVE values (Fornell and Larker, 1981). In general, the square root of the AVE for a construct should be greater than the correlations between that construct and all other constructs. As shown in Table IV, the square roots of the AVE are greater than any of the corresponding correlations. Hence, our scales exhibit appropriate discriminant validity. We seek additional support for discriminant validity by comparing item loadings and cross-loadings in Table III. All the items load substantially higher on intended construct than on other constructs, thus further suggesting our scales possessed adequate discriminant validity (Fornell, 1992).

Construct	M	SD	SK	$\alpha$	1	2	Construct 3	4	5	6
1. Service quality	4.28	0.57	-0.37	0.87	0.75					
2. Process feature	4.17	0.52	-0.12	0.86	0.62	0.85				
3. Product variety	3.68	0.78	-0.78	0.71	0.50	0.46	0.88			
4. Focused attention	3.75	0.79	-0.31	0.90	0.65	0.64	0.39	0.91		
5. Interactivity	3.89	0.65	-0.62	0.72	0.35	0.30	0.27	0.33	0.83	
6. Behavioral intention	4.09	0.71	-0.79	0.86	0.36	0.44	0.16	0.52	0.19	0.71

Notes: M, mean construct score (unweighted); SD, standard deviation; SK, skewness;  $\alpha$ , Cronach's alpha; CR, composite reliability; AVE, average variance extracted; PRO, product offerings; ACC, account; INF, information; SYS, system; FAT, focused attention; INT, interactivity; BI, behavioral intention

**Table IV.** Descriptive statistics, reliability, correlations, and discriminant validity

Examining Common Method Bias Analysis

Because each respondent answers question items pertaining to both independent and dependent variables, we must assess potential common method bias, though the specificity of the measurement items and our use of adequate anchors for different scales should reduce this bias. We first perform Harmon's single-factor test using EFA to determine if a single factor emerges or a general factor accounts for the majority of the covariance. Our results indicate nine factors, none of which accounts for the majority of the variances. We also employ a technique suggested by Podsakoff et al. (2003). Our results reveal that when adding a latent variable that represents common method, model fit improved ( $\chi^2$  difference = 368.34, df = 45,  $p < 0.05$ ) but the variance accounted for by the common method latent variable was only 4.3 percent of the total variance. Together, these results suggest that common method bias is not a serious threat to our analysis (Calson and Perrewew, 1999; Williams et al., 1989).



## Analysis and Results

### TR vs Service System Interfaces, Flow Experience, and Behavioral Intention: Testing H1a-H1c

To test the first set of hypotheses that TR segments differ in evaluation of service system interfaces, flow experience, and behavioral intention, we conduct analysis of variance (ANOVA). Table V presents ANOVA analysis results: means, standard deviations, and statistical comparison among the five TR segments and the between-subject comparison of service system interfaces, flow experience, and behavioral intention. The between-subject analysis in Table V shows that TR segments do perceive service system interfaces differently and vary in their focused attention. Overall, the performance of service system interfaces and focused attention deteriorate as we move from pioneers and explorers, to paranoids, and then laggards and skeptics. However, there is no significant difference in terms of interactivity and behavioral intention across TR segments. Thus, we conclude that H1a is supported, H1b is partially supported, and H1c is not supported.

	Mean (standard deviation)					<i>F</i>
	1. Explorers	2. Pioneers	3. Skeptics	4. Paranoids	5. Laggards	
Service quality	4.44	4.32	4.13	4.36	4.15	3.47**
	0.51	0.53	0.57	0.53	0.65	
Process feature	4.3	4.34	4.02	4.22	4.03	4.08*
	0.48	0.48	0.52	0.46	0.61	
Product variety	3.79	4.1	3.58	3.69	3.4	3.82*
	0.86	0.62	0.57	0.72	0.96	
Focused attention	3.72	4.29	3.58	3.79	3.74	3.61**
	0.85	0.76	0.75	0.75	0.72	
Interactivity	3.98	3.74	3.9	3.93	3.77	1.02
	0.69	0.52	0.65	0.57	0.75	
Behavioral intention	4.11	4.35	3.96	4.13	4.05	1.42
	0.79	0.56	0.63	0.69	0.78	

Note: Significance at: \* $p \leq 0.005$  and \*\* $p \leq 0.01$

**Table V.** ANOVA analysis of TR segments

### Service System Interfaces, Flow Experience, and Behavioral Intention: Testing H2 and H3

To test the hypothesis of H2, we apply partial least square (PLS) method to investigate the proposed relationships among service system interface and flow experience. Based on component construct concept, PLS is ideally suited to the early stage of theory building and testing and especially appropriate when the researcher is primarily concerned with prediction of the dependent variable (Fornell and Bookstein, 1982). Compared with two-stage least squares, PLS considers all path coefficients simultaneously and allow direct, indirect, and spurious relationships and estimates the individual item weightings in the context of the theoretical model rather than in isolation (Birkinshaw et al., 1995). Compared with other



multivariate analysis such as LISREL program, which is better suited for theory testing, PLS is better suited for explaining complex relationship (Fornell and Bookstein, 1982). In addition, PLS procedure has been gaining interest and use among business research because of its ability to model latent constructs under conditions of non-normality and small to medium sample sizes (Chin et al., 2003).

The results of PLS estimation are shown in Figure 1. The path coefficients obtained from a PLS analysis are standardized regression coefficients, while the loadings of items on individual constructs are factor loadings. PLS has its primary objective of minimizing errors (or the maximization of variance explained) in all endogenous constructs. The degree to which the PLS model accomplishes such an objective can be determined by examining the R<sup>2</sup> values for the dependent (endogenous) constructs. As shown in Figure 1, majority of the relationships examined are significant. The impact of service system interfaces on flow experience (H2) is statistically significant and positive, with the exception of product offerings, which poses a negative effect on interactivity. The result suggests that an increasing range of product offerings may reduce the degree of customer-system interactions.

The direct causal effect from “process feature” to “behavioral intention” is 0.25. The direct causal effects from “process feature” to “focused attention” and “interactivity” are 0.28 and 0.34, respectively. The direct causal effects from “focused attention” and “interactivity” to

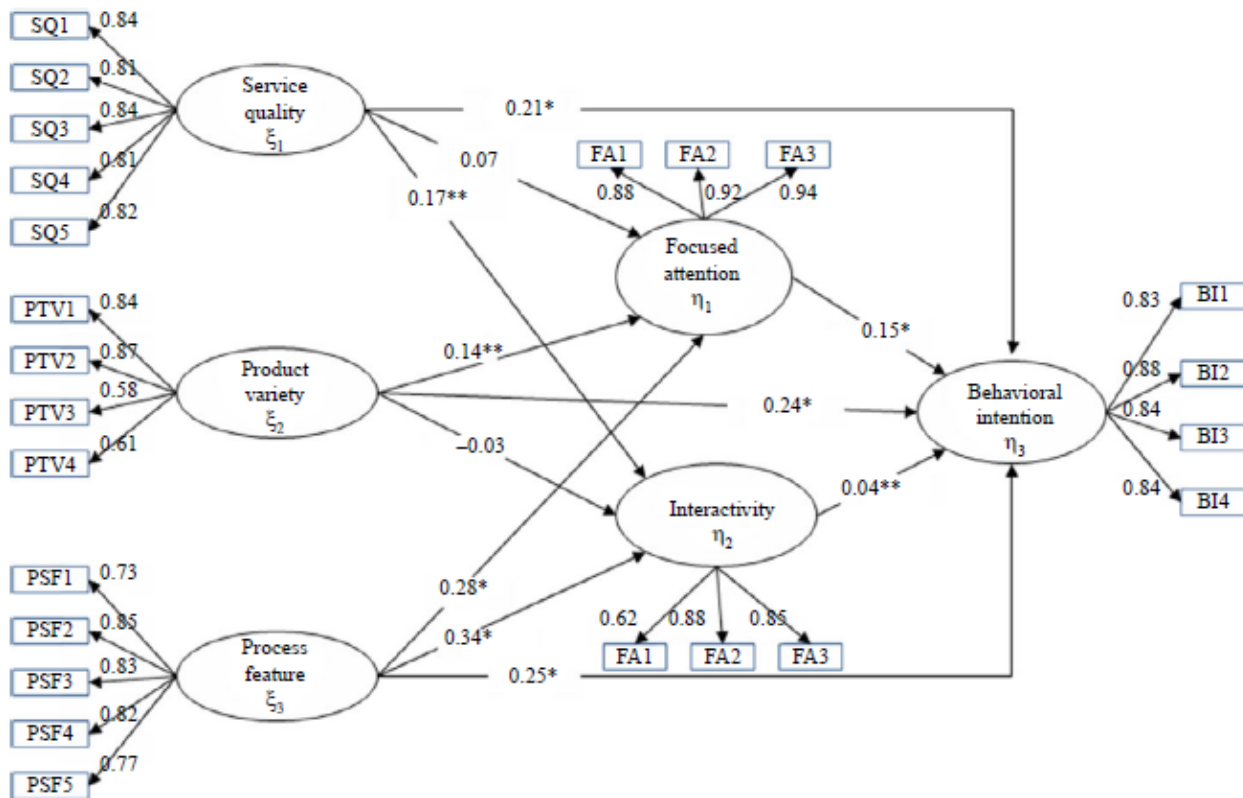

Note: Significance at: \* $p \leq 0.005$  and \*\* $p \leq 0.01$

Figure 1. Latent path model for e-brokerage service behavioral intention

“behavioral intention” are 0.15 and 0.04, respectively. Hence, the total influence from “process feature” on “behavioral intention” adds up to 0.31 ( $0:25 + 0:28 * 0:15 + 0:34 * 0:04$ ). The total effect of “service quality” on “behavioral intention” is 0.23. The total effect of “product variety” on “behavioral intention” is 0.26. The impacts of both service system interfaces and flow experience on behavioral intention are all statistically significant and positive. Although most of the hypotheses are supported in the analysis, the process feature is twice as important as the next closed drivers in driving flow experience of focused attention and interactivity, respectively.

Overall, the model explains 45 percent of the variance in behavioral intention, 20 percent of the variance in interactivity, and 18 percent of the variance in focused attention. As shown in Figure 1, flow experience partially mediates the relationship between service system interfaces and behavioral intention. Thus, we conclude that *H2* and *H3* are supported.

### Discussion

As the economic woes continue, major financial institutions strive to improve their performance by downsizing their brick-and-mortar business. During the downsizing process, it is very likely that customers rely more on other alternative channels such as online self-service for their financial needs. Although the advanced technology makes the transition from brick-to-mortar to online self-service possible, the technology itself does not guarantee success. Instead, financial institutions alike need to examine customers’ attitude towards technology-oriented service and deliberately choose a set of activities to deliver a unique experience to compete with other service providers (Ding et al., 2010). In this study, we investigate how technology beliefs affect customers’ experience and evaluation of specific service system interfaces. Specifically, we propose that the willingness to try out technology-oriented service affects the evaluation of certain service system interfaces and corresponding behavioral intentions.

At a granular level, TR typology provides a foundation for understanding how customers with varying TR evaluate service system interfaces differently. As shown in Table V, skeptics- and laggards-rated service quality, process feature, and product variety lower than the other three segments. As we discuss in the previous section, service quality, process feature, and product variety present the set of service system interfaces as humanic, functional, and mechanic clues. With the lowest contributors (optimism and innovativeness) among all five segments, skeptics and laggards tend to be least optimistic about the service components staged on the e-brokerage sites. Consequently, they tend to have less compelling experience and are less likely to be loyal customers than other segments.

In contrast, explorers- and *pioneers*-rated service quality, process feature, and product variety higher than the other three segments. Compared with other segments, explorers are extremely high in TR, ranking highest on contributors (optimism and innovativeness) and lowest on inhibitors (discomfort and insecurity). They are highly motivated and fearless and are typically at the leading edge of trying out technology-based products or services. Although

explorers tend to learn technology on their own, they might be too optimistic when encountering challenges associated with their financial investments through e-brokerage accounts. While pioneers share the contributors (optimism and innovativeness) tendencies of the explorers, they have a certain degree of inhibitors (discomfort and insecurity), which indicates that they desire the benefits of the technology but are well aware of the difficulties and challenges while trying out the technology than explorers. Therefore, pioneers tend to have more compelling experience and are more likely to be loyal customers than explorers.

Lastly, paranoids exhibited moderate levels of contributors (optimism and innovativeness) and inhibitors (discomfort and insecurity) and reacted indifferently to service system interfaces. The results reveal that the contributors or inhibitors alone do not necessarily determine the experience and attitude towards service system interfaces. Instead, it is the combination of both incentives (e.g. contributors) and readiness to challenges (e.g. inhibitors) that further stimulates reasonable expectations and determines customer experience of service system interfaces.

In summary, Table V suggests four instead of five subgroups. The first group of explorers is tech savvy, seeks novel e-services with real value, and therefore is labeled as true innovators. The second group of pioneers seeks novel online technology with excellent service quality and process features but shows limited interests in a broad and complex core offering (e.g., the variety of options for investment). In this connection, we label them as tech seekers. The third group of skeptics and laggards tends to emphasize on core offerings from the service system by placing significant weights on product variety. Both segments seem to be happy with an e-only service channel given sufficient customer support and system features and therefore constitutes smart shoppers. The fourth group of paranoids needs little convincing by the technology-ready marketer and support from the customer representative so that they will benefit from the service (Parasuraman and Colby, 2001). Hence, we label them with tech inhibitors.

In this study, we also examine Ding et al. (2010) dual-layer customer experience model in a latent path model. As shown in Figure 1, the dual-layer customer experience model is supported and both layers positively contribute to behavioral intention. In other words, flow experience mediates the connection between service system interfaces and behavioral intention. We compare the  $R^2$  for the construct of behavioral intention with/without the second layer of flow experience – adding the second layer of flow experience in the latent path model increase  $R^2$  by 5.6 percent and both focused attention and interactivity affect behavioral intention positively at the significance level of  $p \leq 0.01$ .

While we found that customer experience and intention differ across TR clusters, we found that most of the variance in customer experience and intention can be explained via customers' evaluation of service system interfaces. From a service research perspective, our research framework sheds lights on the debate over human issues in service design by moving away from the long-fought battle for the impact of technology (e.g. technology acceptance model, TR scale) toward a finer-grained quest for when some firms can derive more loyal

customers from experience design than others (Chase and Dasu, 2001; Cook et al., 2002). Second, it provides us a unique opportunity to contributing to the service literature: we are among the first to confirm the importance of explicit physical structures (e.g. service, process, and product) in eliciting implicit psychology and emotion of customers (Schmenner and Swink, 1998; Roth and Menor, 2003). Third, it seeks to advance our understanding of different types of variability introduced by customers (e.g. effort, capability, and subjective preference) during the service production process (Frei, 2006; Ding et al., 2010).

### **Conclusion**

This study extends current service research by applying a revised service design planning model to examine the relationships among input (e.g. psychographics), service system (e.g. service quality, process feature, and product variety), output (e.g. customer experience), and performance (e.g. behavioral intention) in e-brokerage setting. This study contributes to extant research and practice on service design in several ways. First of all, it is among the first attempts to examine how psychographic features affect customers' experience and valuation of certain service system interfaces from a service design perspective (Goldstein et al., 2002). Specifically, we apply TR to capture customers' beliefs about technology and investigate how customers with varying technology beliefs evaluate service system interfaces differently. With regards to our hypotheses, our empirical results provide evidence that the TR segments differ in their evaluation of relevant system interfaces pertaining to e-brokerage service.

Our study addresses a tactical decision in service design – how does the design of service system interfaces affects a firm's relationship with its customers. Apparently, all design elements including service quality, process feature, and product variety contribute to behavioral intention. After considering both direct and indirect effects, process feature tends to have the strongest effect on behavioral intention, following by product variety and service quality. A close look of Table V also suggests that different TR segments tend to value service quality most, following by process feature and product variety. This research finding is contradicting with the earlier study by Krishnan et al. (1999), where product offerings was ranked as the primary driver of customer satisfaction. Yet the contradiction might be explained with the evolving roles of self-service technology and online financial research, which lately have made it easier for customers to access a variety of investment options and research tools (Ding et al., 2007). Consequently, self-trained online investors incline to focus more on the trading process, with higher expectation for an easily accessible service support and a reliable and 24/7 available process.

Using a strategic lens, e-brokerage providers can customize and fine-tune service system interfaces based on customers' demographics and technology beliefs. The customization process starts with a simple sorting task. For instance, e-brokers can use certain incentives to attract both first-time users and existing customers to complete their profiles with basic demographics and technology beliefs. By integrating certain simple programs on the server, customers will be automatically sorted into pre-determined groups and be exposed to pre-

selected service packages based on their psychographics. The service packages can be customized based on the results shown in Tables V and VI. For instance, true innovators (explorers) are consistently seeking novel ways to manage their e-brokerage accounts. Therefore, they are very likely to use sophisticated analytical and trading tools and manage their accounts and/or place trades through their portable devices. In addition, they might also feel comfortable with virtual customer service such as live chat. E-brokers might consider providing advanced analytical tools or packages to explorers at a discounted rate, allowing them to access mobile trading and mobile trade terminals, and offering customer service through live chat or voice chat. In contrast, Tech Inhibitors (paranoids) are grudgingly accepting technology-enabled services and exhibit a high level of discomfort and insecurity. Consequently, they are unlikely to enjoy the interaction with their e-brokerage accounts. Instead, they might feel more comfortable with the brick-and-mortar environment. To address their needs, e-brokers need to provide a step-by-step assistance, training modular and detailed Q&A guidelines to help reduce their anxiety associated with the trading process. Moreover, e-brokers might also consider offering assistance through multiple channels (e.g., live chat, 1-800 free toll numbers, access to local branch, email, and fax) to Tech Inhibitors. Finally, customer representatives need to be trained to explain technical terms or answer questions in different tones and at varying speeds. In this case, it might be helpful to use scripts to guide the training

	Service quality	Process feature	Product variety	Focused attention	Interactivity	$R^2$
<i>Explorers</i>						
Focused attention	0.173	0.402	0.123			0.335
Interactivity	-0.005	0.548	0.003			0.299
Behavioral intention	0.331	0.267	0.321	0.005	0.094	0.585
<i>Pioneers</i>						
Focused attention	0.72	0.026	0.114			0.677
Interactivity	0.419	0.382	0.051			0.563
Behavioral intention	0.783	0.601	-0.403	0.087	-0.138	0.741
<i>Skeptics</i>						
Focused attention	-0.097	0.28	0.199			0.132
Interactivity	0.26	0.042	0.138			0.13
Behavioral intention	0.103	0.327	0.311	0.031	-0.1	0.338
<i>Paranoids</i>						
Focused attention	-0.135	0.326	0.129			0.118
Interactivity	0.026	0.67	-0.094			0.405
Behavioral intention	0.306	0.197	0.166	0.27	0.108	0.545
<i>Laggards</i>						
Focused attention	0.236	0.01	0.308			0.201
Interactivity	0.343	0.35	-0.178			0.329
Behavioral intention	0.185	0.118	0.315	0.047	0.259	0.431

**Table VI.** Path coefficients ( $\beta$ ) and  $R^2$  across five TR segments

process. For instance, customer representatives can simply direct true innovators (explorers) to certain web pages or tools for a quick fix of their problems, yet they need to slowdown and offer a step-by-step guidance while assisting tech inhibitors (paranoids).

We further examine the variation of the dual-layer experience model (Ding et al., 2010) across five TR segments and show that customers with different technology beliefs, when encountering the technology-based service, tend to value service system interfaces differently and hence formulate their flow experience in different ways. As suggested by the path coefficients in Figure 1, the dual-layer construct is well supported with all path coefficients significant at  $p \leq 0.01$ . Yet at individual TR cluster level, the path coefficients are quite robust to the combination of contributors and inhibitors. For instance, while product variety has a negative effect on interactivity for the TR clusters of paranoids and laggards, such an effect turns out to be positive for the other three TR clusters of explorers, pioneers, and skeptics. Therefore, while Figure 1 reveals that the diversity of investment options and research tools tend to reduce the level of interactions and further reduce the level of behavioral intention at an aggregate level, a closer look at Table VI reveals that such a conclusion does not hold for the explorers, pioneers, and skeptics. The findings indicate that service designers need to examine the life cycle of the intended service offerings and customize corresponding service/product features based on customers' technology beliefs and personal characteristics, which can further lead to maximized flow experience and increased intention rate. Finally, the testing results from the PLS model indicate that flow experience emerges as an important factor for achieving sustainable competitive advantages in e-brokerage service – adding the second layer of flow experience in the latent path model helps explain additional 5.6 percent variance in behavioral intention. As online service providers (e.g. WebMD.com, Webkinz.com, and Barbie.com) have been integrating experience design to enhance customer overall experience, e-brokerage service providers can also apply experience management to achieve long-term competitive advantages. Towards this end, this research builds the cornerstone for future research to further apply the dual-layer experience construct in service design planning models in other service contexts.

### **Limitations**

All research has certain limitations and this study is certainly not an exception. First, we choose to study e-brokerage industry, which suffers most in current down-turn economy. Owing to the high-tech and high-credence characteristics, the research findings and relevant hypotheses might not applicable to other services. Therefore, future studies should examine the proposed structural model in other service contexts. In addition, this study used pilot study and exploratory surveys to refine the survey questions, yet it might still have biases and limitations due to the choice of questions and method of data collection. It might be interesting to use field study and focused groups to further examine the hypotheses in a controlled environment.

## References

- Anderson, E. (2007), "Marketing technology adoption 2007", *Forrester Research*, Vol. 26, April, pp. 1-14.
- Anderson, E.W. and Sullivan, M.W. (1993), "The antecedents and consequences of customer satisfaction for firms", *Marketing Science*, Vol. 12 No. 1, pp. 125-43.
- Auh, S., Bell, S.J., McLeod, C.S. and Shih, E. (2007), "Co-production and customer loyalty in financial services", *Journal of Retailing*, Vol. 83 No. 3, pp. 359-70.
- Bailey, J.E. and Pearson, S.W. (1983), "Development of a tool for measuring and analyzing computer user satisfaction", *Management Science*, Vol. 29 No. 5, pp. 530-44.
- Balasubramanian, S., Konana, P. and Menon, N.M. (2003), "Customer satisfaction in virtual environments: a study of online investing", *Management Science*, Vol. 49 No. 7, pp. 871-89.
- Berry, L.L., Wall, A.E. and Carbone, L.P. (2006), "Service clues and customer assessment of the service experience: lesson from marketing", *Academy of Management Perspective*, Vol. 20 No. 2, pp. 43-57.
- Birkinshaw, J., Morrison, A. and Hulland, J. (1995), "Structural and competitive determinants of a global integration strategy", *Strategic Management Journal*, Vol. 16, pp. 637-55.
- Bitner, M.J. and Brown, S.W. (2006), "The evolution and discovery of services science in business schools", *Communication of the ACM*, Vol. 49 No. 7, pp. 73-8.
- Brush, T.H. and Artz, K.W. (1999), "Toward a contingent resource-based theory: the impact of information asymmetry on the value of capabilities in veterinary medicine", *Strategic Management Journal*, Vol. 20 No. 3, pp. 223-50.
- Calson, D.W. and Perrewé, P.L. (1999), "The role of social support in the stressor-strain relationship: an examination of work-family conflict", *Journal of Management*, Vol. 25, pp. 513-40.
- Carbone, L.P. and Haeckel, S.H. (1994), "Engineering customer experiences", *Marketing Management*, Vol. 3 No. 3, pp. 9-19.
- Chase, R.B. and Dasu, S. (2001), "Want to perfect your company's service?", Use behavioral science. *Harvard Business Review*, Vol. 79 No. 6, pp. 78-84.
- Chen, P.Y. and Hitt, L.M. (2003), "Measuring switching costs and the determinants of customer retention in internet-enabled businesses", *Information Systems Research*, Vol. 13 No. 3, pp. 255-74.

- Chin, W.W., Marcolin, B.L. and Newsted, P.R. (2003), "A partial least squares latent variable modeling approach for measuring interaction effects: results from a Monte Carlo simulations study and electronic-mail emotion/adoption study", *Information System Research*, Vol. 14 No. 2, pp. 189-217.
- Churchill, G. (1979), "A paradigm or developing better measures of marketing constructs", *Journal of Marketing Research*, Vol. 16 No. 1, pp. 64-73.
- Cook, L.S., Bowen, D.E., Dasu, S., Chase, R.B., Stewart, D.M. and Tansik, D.A. (2002), "Human issues in service design", *Journal of Operations Management*, Vol. 20 No. 2, pp. 159-74.
- Csikszentmihalyi, M. (1991), *Flow: The Psychology of Optimal Experience*, Harper and Row, New York, NY.
- Csikszentmihalyi, M. (2000), "The costs and benefits of consuming", *Journal of Consumer Research*, Vol. 27 No. 2, pp. 267-72.
- Curran, J.M., Meuter, M.L. and Surprenant, C.F. (2003), "Intentions to use self-service technologies: a confluence of multiple attitudes", *Journal of Service Research*, Vol. 5 No. 3, pp. 209-24.
- DeLone, W.H. and McLean, E.R. (2003), "The DeLone and McLean model of information systems success: a ten-year update", *Journal of Management Information Systems*, Vol. 19 No. 4, pp. 9-30.
- Ding, X., Verma, R. and Iqbal, Z. (2007), "Self-service technology and online financial service choice", *International Journal of Service Industry Management*, Vol. 18 No. 3, pp. 246-68.
- Ding, X., Hu, P.J., Verma, R. and Wardell, D.G. (2010), "The impact of service system design and flow experience on customer satisfaction in online financial services", *Journal of Service Research*, Vol. 13 No. 1, pp. 96-110.
- Doll, W.J., Raghunathan, S.T., Lim, J.S. and Gupta, Y.P. (1995), "A confirmatory factor analysis of the user information satisfaction instrument", *Information Systems Research*, Vol. 6 No. 2, pp. 177-88.
- Emmanouilides, C. and Hammond, K. (2000), "Internet usage: predictors of active users and frequency of use", *Journal of Interactive Marketing*, Vol. 14 No. 2, pp. 17-32.
- Etgar, M. (2008), "A descriptive model of the consumer co-production process", *Journal of the Academy of Marketing Science*, Vol. 36 No. 1, pp. 97-108.
- Fishbein, M. and Ajzen, I. (1975), *Attitude, Intention, and Behavior: An Introduction to Theory and Research*, Addison-Wesley, Reading, MA.



- Flynn, B.B., Sakakibara, S., Schroeder, R.G., Bates, K.A. and Flynn, E.J. (1990), "Empirical research methods in operations management", *Journal of Operations Management*, Vol. 9 No. 2, pp. 250-84.
- Fornell, C. (1992), "A national customer satisfaction barometer: the Swedish experience", *Journal of Marketing*, Vol. 56, pp. 6-21.
- Fornell, C. and Bookstein, F. (1982), "Two structural equations model: LISREL and PLS applied to consumer exit-voice theory", *Journal of Marketing Research*, Vol. 19, pp. 440-52.
- Fornell, C. and Larcker, D.F. (1981), "Evaluating structural equation models with unobserved variables and measurement error", *Journal of Marketing Research*, Vol. 18 No. 1, pp. 39-50.
- Frei, F.X. (2006), "Breaking the trade-off between efficiency and service", *Harvard Business Review*, Vol. 84 No. 11, pp. 92-103.
- Froehle, C.M. (2006), "Service personnel, technology, and their interaction in influencing customer satisfaction", *Decision Sciences*, Vol. 37 No. 1, pp. 5-38.
- Gefen, D., Straub, D.W. and Boudreau, M.C. (2000), "Structural equation modeling and regression: guidelines for research practice", *Communications of the AIS*, Vol. 4 No. 7, pp. 1-77.
- Gerbing, D.W. and Anderson, J.C. (1988), "An updated paradigm for scale development incorporating unidimensionality and its assessment", *Journal of Marketing Research*, Vol. 25, pp. 186-92.
- Ghani, J.A. and Deshpande, S.D. (1994), "Task characteristics and the experience of optimal flow in human-computer interaction", *Journal of Psychology*, Vol. 128 No. 4, pp. 381-91.
- Goldstein, S.M., Johnston, R., Duffy, J. and Rao, J. (2002), "The service concept: the missing link in service design research", *Journal of Operations Management*, Vol. 20 No. 2, pp. 121-34.
- Gupta, S. and Vajie, M. (1999), "The contextual and dialectical nature of experiences", in Fitzsimmons, J. and Fitzsimmons, M. (Eds), *New Service Development*, Sage, Thousand Oaks, CA, pp. 33-51.
- Gupta, S., Lehmann, D.R. and Stuart, J. (2004), "Valuing customers", *Journal of Marketing Research*, Vol. 41 No. 1, pp. 7-18.
- Harman, H.H. (Ed.) (1976), *Modern Factor Analysis*, The University of Chicago Press, Chicago, IL.
- Huffman, D.L., Kalsbeek, W.D. and Novak, T.P. (1996), "Internet and web use in the United States: baselines for commercial development", *Communications of the ACM*, Vol. 39, pp. 36-46.

- Johnston, R. and Clark, G. (2001), *Service Operations Management*, Prentice-Hall, Harlow.
- Korzaan, M.L. (2003), "Going with the flow: predicting online purchase intentions", *Journal of Computer Information Systems*, Vol. 43 No. 4, pp. 25-31.
- Krishnan, M.S., Ramaswamy, V., Meyer, M.C. and Damien, P. (1999), "Customer satisfaction for financial services: the role of products, services, and information technology", *Management Science*, Vol. 45 No. 9, pp. 1194-209.
- Langeard, E., Bateson, J.E.G., Lovelock, C.H. and Eigler, P. (1981), *Services marketing: new insights from consumers and managers*, Report No. 81-104, *Marketing Science Institute*, Cambridge, MA.
- Lovelock, C.H. (2001), *Services Marketing: People, Technology, Strategy*, Prentice-Hall, Englewood Cliffs, NJ.
- McCarthy, J. and Wright, P. (2004), *Technology as Experience*, The MIT Press, Cambridge, MA.
- Massey, A.P., Khatri, V. and Montoya-Weiss, M.M. (2007), "Usability of online services: the role of technology readiness and context", *Decision Sciences*, Vol. 38 No. 2, pp. 277-308.
- Menor, L.J. and Roth, A.V. (2008), "New service development competence and performance: an empirical investigation in retail banking", *Journal of Operations Management*, Vol. 17 No. 3, pp. 267-84.
- Mills, P.K., Chase, R.B. and Margulies, N. (1983), "Motivating the client/employee system as a service production strategy", *Academy of Management Review*, Vol. 8 No. 2, pp. 301-10.
- Nelson, R.R., Todd, P.A. and Wixom, B.H. (2005), "Antecedents of information and system quality: an empirical examination within the context of data warehousing", *Journal of Management Information Systems*, Vol. 21 No. 4, pp. 199-235.
- Newbert, S.L. (2007), "Empirical research on the resource-based view of the firm: an assessment and suggestions for future research", *Strategic Management Journal*, Vol. 28, pp. 121-46.
- Novak, T.P., Hoffman, D.L. and Yung, Y. (2000), "Measuring the customer experience in online environments: a structural modeling approach", *Marketing Science*, Vol. 19 No. 1, pp. 22-42.
- Nunnally, J.C. (1978), 2nd ed., *Psychometric Theory*, McGraw-Hill, New York, NY.
- Parasuraman, A. (2000), "Technology-readiness index (TRI): a multiple-item scale to measure readiness to embrace new technologies", *Journal of Service Research*, Vol. 2 No. 4, pp. 307-20.
- Parasuraman, A. and Colby, C.L. (2001), *Techno-ready Marketing*, The Free Press, New York, NY.

- Parasuraman, A., Zeithaml, V. and Malhotra, N. (2005), "E-S-QUAL: a multiple-item scale for assessing electronic service quality", *Journal of Service Research*, Vol. 7 No. 3, pp. 213-33.
- Pavlou, P.A. and Fyngenson, M. (2006), "Understanding and predicting electronic commerce adoption: an extension of the theory of planned behavior", *MIS Quarterly*, Vol. 30 No. 1, pp. 115-43.
- Pine, B.J. and Gilmore, J.H. (1998), "Welcome to the experience economy", *Harvard Business Review*, Vol. 76 No. 4, pp. 97-105.
- Podsakoff, P.M., MacKenzie, S.B. and Podsakoff, N.P. (2003), "Common method biases in behavioral research: a critical review of the literature and recommended remedies", *Journal of Applied Psychology*, Vol. 88 No. 5, pp. 879-903.
- Porter, M.E. (2001), "Strategy and the internet", *Harvard Business Review*, Vol. 79, pp. 63-78.
- Prahalad, C.K. and Ramaswamy, V. (2000), "Co-opting customer experience", *Harvard Business Review*, Vol. 78 No. 1, pp. 79-87.
- Pullman, M.E. and Gross, M.A. (2004), "Ability of experience design elements to elicit emotions and loyalty behaviors", *Decision Sciences*, Vol. 35 No. 3, pp. 551-78.
- Reibstein, D.J. (2002), "What attracts customers to online stores, and what keeps them coming back", *Academy of Marketing Science*, Vol. 30 No. 4, pp. 465-73.
- Roth, A.V. and Menor, L.J. (2003), "Insights into service operations management: a research agenda", *Production and Operations Management*, Vol. 12 No. 2, pp. 145-63.
- Schmenner, R.W. and Swink, M.L. (1998), "On theory in operations management", *Journal of Operations Management*, Vol. 17 No. 1, pp. 97-113.
- Taylor, S.A., Celuch, K. and Goodwin, S. (2002), "Technology readiness in the e-insurance industry: an exploratory investigation and development of an agent technology e-consumption model", *Journal of Insurance Issues*, Vol. 25 No. 2, pp. 142-65.
- Tsikriktsis, N. (2004), "A technology readiness-based taxonomy of customers: a replication and extension", *Journal of Service Research*, Vol. 7 No. 1, pp. 42-52.
- Williams, R.T., Cote, J.A. and Buckley, R. (1989), "Lack of method variance in self-reported affect and perceptions at work: reality or artifact", *Journal of Applied Psychology*, Vol. 81, pp. 88-101.
- Wixom, B.H. and Todd, P.A. (2005), "A theoretical integration of user satisfaction and technology acceptance", *Information System Research*, Vol. 16 No. 1, pp. 85-102.

Wolfenbarger, M. and Gilly, M.C. (2003), "eTailQ: dimensionalizing, measuring and predicting e-Tail quality", *Journal of Retailing*, Vol. 79 No. 3, pp. 183-97.

Zeithaml, V.A., Berry, L.L. and Parasuraman, A. (1996), "The behavioral consequences of service quality", *Journal of Marketing*, Vol. 60, pp. 31-46.

### **Further Reading**

Kellogg, D.L. and Nie, W. (1995), "A framework for strategic service management", *Journal of Operations Management*, Vol. 13, pp. 323-37.

### **Appendix. Measurement for TR**

#### TR scale

Innovativeness:

- RC1 – I can usually figure out new hi-tech products and services without help from others.
- TRC7 – In general, I am among the first in my circle of friends to acquire new technology when it appears.

Optimism:

- TRC3 – I like the idea of doing business via computers because I am not limited to regular business hours.
- TRC5 – Technology gives people more control over their daily lives.
- TRC9 – Technology makes me more efficient in my occupation.

Discomfort:

- TRC2 – New technology is often too complicated to be useful.
- TRC4 – When I get technical support from a provider of a high-tech product or service, I sometimes feel as if I am being taken advantage of by someone who knows more than I do.

Insecurity:

- TRC6 – I do not consider it safe giving out credit card information over a computer.
- TRC8 – I do not feel confident doing business with a place that can only be reached online.
- TRC10 – If I provide information to a machine or over the internet, I can never believe if it really gets to the right place.

### **Corresponding author**

Xin David Ding can be contacted at: [xding@uh.edu](mailto:xding@uh.edu)