



[Vijayakumar\* *et al.*, 5(6): June, 2016]  
ICT<sup>™</sup> Value: 3.00

ISSN: 2277-9655  
Impact Factor: 4.116



## INTERNATIONAL JOURNAL OF ENGINEERING SCIENCES & RESEARCH TECHNOLOGY

### PERFORMANCE ANALYSIS OF ADAPTIVE MULTIPLE QUEUING DISCIPLINES (AMQD) FOR VOIP ROUTING IN RANDOM WAY POINT MOBILITY MODEL OVER MANET SCENARIO

M. Vijayakumar\*, V. Karthikeyani

\* Department of Computer Science, K.M.G College, India  
Department of Computer Science, Govt. Arts College for Women, Selam, India

DOI:

#### ABSTRACT

In Mobile Ad hoc Network (MANET), QoS (Quality of Services) in VOIP application plays an extremely significant responsibility. Queuing disciplines is an issue of concentrated conversation and research in the wireless network field for development of packets from dissimilar traffic flow for dispensation at an exact node. Hence Mobility takes an important role in networks to evaluate the presentation of AMQD with different Codec's for voice Over Internet. VOIP is an accepted Internet application to provide high-quality services through Mobile Ad hoc Network (MANET). Based on the analysis and assessment of different mobility models such as Random Waypoint Models, Reference point group models, Manhattan Mobility models, it is pointing out that this network also faces a lot of challenges on QoS issue upon the node movement of different mobility. The QoS issues such as packet loss, less throughput, more delay, jitter issues and high energy consumption, Combine these issues together with mobility models, in this paper the researcher estimates the performance of various VOIP codec with Adaptive Multiple Queuing Disciplines (AMQD) namely, IAE3, DBPQ, CBCRTQ over MANET. Simulation and GUI experiments demonstrate the comparative analysis of different queuing in quality of services parameters.

**KEYWORDS:** QoS (Quality of Services), AMQD (Adaptive Multiple Queuing Disciplines), IAE3 (Intelligent Adaptive Energy Efficiency & Effective signal), DBPQ (Distance Based Priority queue), CBCRTQ (Class Based Cluster Round Trip Queue), MANET (Mobile Ad hoc Network).

#### INTRODUCTION

Wireless communication enable a user to admission the communication services at anytime from wherever approximately the world MANETs are decentralized scheme consisting of movable nodes ready with wireless message devoid of any admission point, MANET application are essentially troubled for voice transmission over IP network like tele-emergency system that wants voice communication.[5] Voice over IP is an extremely well-liked skill that allows the message over packet switch network in its place of route switched network. In spite of the rising status of data services, voice services unmovable stay the main profits basis for system repair provider. The two most well-liked conduct of as long as influence and wireless cellular networks. The use of both of this form of network requires infrastructures that are typically very classy.[7][8] Option solution is life form required which can bring good-quality say services at a comparatively lower cost. One method to attain low cost is to use the previously existing IP infra-structure

#### RELATED WORK

The random waypoint replica is a usually used mobility model for simulations of wireless communication networks. By giving an official account of this representation in conditions of a discrete-time stochastic procedure, we examine a number of its basic stochastic property with high opinion to: (a) the change length and occasion of a mobile node between two waypoints, (b) the spatial sharing of nodes, (c) the direction angle at the commencement of an association transition, and (d) the cell modify rate if the model is used in a cellular-structured scheme area.[9]

Mobile Ad-hoc Network (MANET) was distinct as a set of mobile nodes that enthused generously and linked amongst each other without any communications. Limitation represents a tool that evaluates the presentation of an obtainable or future queuing system, under dissimilar configurations of attention and over long period of real time.[4]

**COMPARISON OVERVIEW OF ADAPTIVE MULTIPLE QUEUING DISCIPLINES (AMQD) MECHANISM FOR VOIP (QOS) OVER MANET**

Advanced Queuing plan determine the regulation for order entity in a queue. It defines the order in which they are serve and the way in which capital are alienated between patrons (packets). Each router must equipment some queueregulation to govern the packetbuffer in which packetto come to be transmitting. Queueconjectureconstitute a influential tool in model and presentation analysis of a lot of multifacetedsystem, such as computer network, telecommunication system, call centers, developed systems and repair systems. The proposed multiple queuing mechanisms play a vital role in Voice over Internet Protocol over manet environment.[1][2]

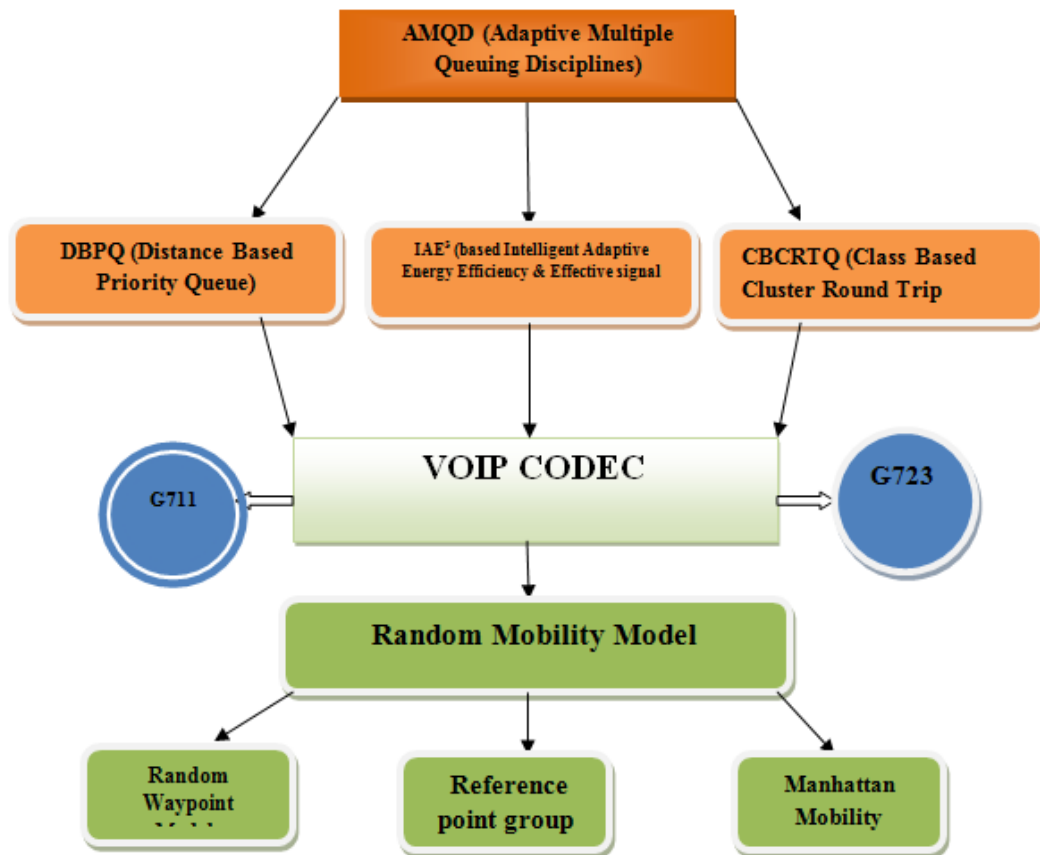
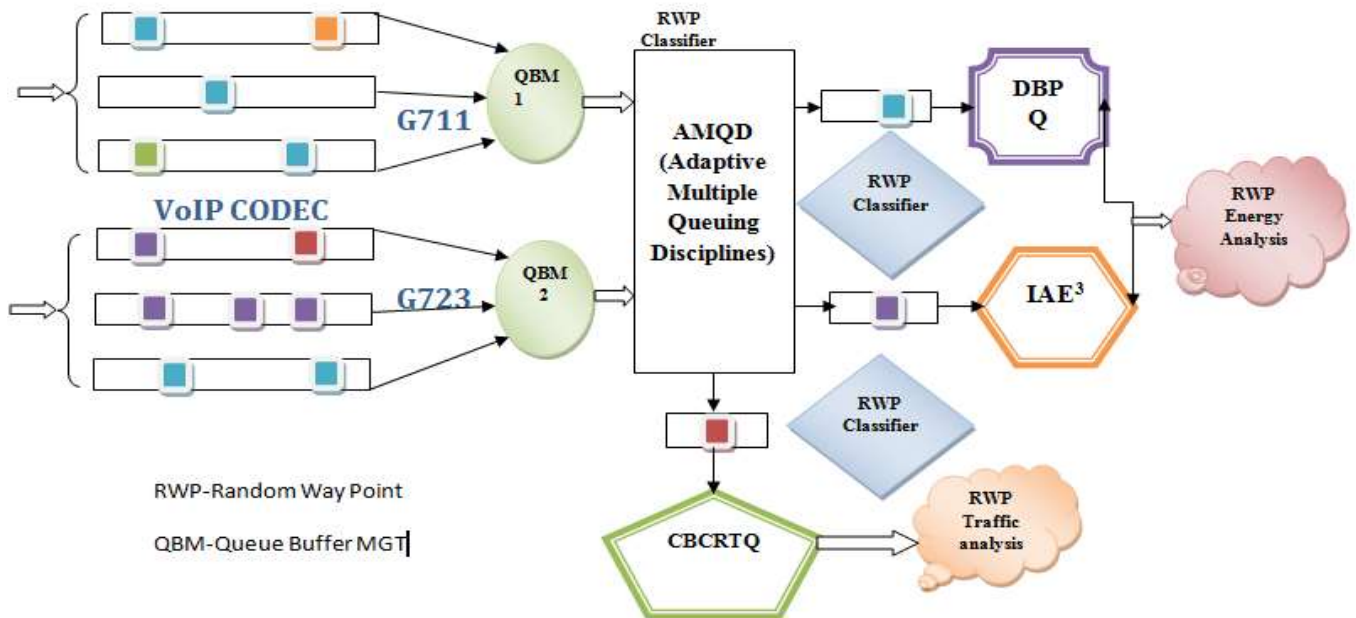

Fig 1: Classification Diagram of (AMQD)

**INTELLIGENT PERFORMANCE METRICS**

Go toward to the arrangement measurement is to get the codec data by monitor the events and performance on an accessible scheme. Act replicate profits in place of the system by a symbol and influence the model to get in arrange about its events and its performance. The queue routine of the understanding can be conventional also directly or by differentiate the system workload mean reply time,[11] the total service time, the workflow, the in order of finished or abortment needs, the total to come time, the line length, the figure of transactions finished per unit time, the proportion of blocked association requests. To assess the MANET as a queuing system, there are a lot of other presentation metrics that can be used. [13]



*Fig 2: Functional Diagram of Proposed AMQD Mechanism*

Our ultimate aim is to reduce the energy consumption and increase quality of services parameters in MANET environment to ensure and analysis with the help of the random waypoint mobility representation introduced detailed suspension times between movement's i.e. change in track and momentum.[12] The random waypoint model is the majority popular mobility model working in modern research, and can be measured a base for structure other mobility models.[16]

One of the main reasons why the multiple queuing take place node distribution resulting from the RWP model is non-uniform is the fact that nodes take a non-consistently dispersed way angle at the commencement of each group period.[18]

Each node has a prepared queue in which dissimilar type of tasks are placed. Scheduling in the middle of a variety of tasks takes place with the help of schedulers. Number of queues in an exacting node will be relying on the height of the node in the network. It can be unspoken that nodes that are available in lowest level will not receive packets from distant site and hence does not need more figure of queues. Mostly, multi-level queue can able to keep away from delay since it has more than a few working phases like aligning the tasks among different queues and scheduling. [22][14]

## PROCEDURE FOR RANDOM WAY POINT MOVEMENT

### AMQD Algorithm

#specified nodes position randomly  
#create node movement using Multi queue methodology

### Algorithm

#specified point destination for VOIP codec

### Algorithm

#Start for AMQD algorithm

Initial node While Time Simulation <= 50 do

**Begin**

For i = 0 to number node -1 do

**Begin**

If current\_Queue1\_density (node[i])  
> beside\_Queue2\_density (node[j]) then

**Begin**

Current\_Queue1\_density (node[i])

= Beside\_Queue2\_density (node[j]);

Final Beside\_Queue3\_density (node[k]) =Current  
\_Queue1\_density (node[i]);

**End;**

If isbuffer full Intersection occur then

**Begin**

QBM: = Full;

For j=0 to

Intersection codec number -1 do

**Begin**

If branch Random point edge[j].density <

Branch Random point edge [j + 1].density then

**Begin**

QBM: =Min\_edge;

Min\_edge= j;

**End;**

**End;**

If Packet<min\_edge then

Next Random point edge = branch edge[k];

Else if

Random branch edge [Min\_edge].has traffic

Queue branch edge [Temp].has traffic occur

then

**Begin**

**If**

Port classifier edge [min\_edge].traffic random selection

.color = indicate thennext\_edge =

Branch node [Temp];

**If**

Random node [Temp].traffic buffer

Or=red then

next\_node=branch node [min\_edge];

**End else if not**

Then next\_queue = take place

Random node [QBM];

**End else next\_port =**

Branch Queue3 node selecting [min\_edge];

**End;**

Sumofpassingvertex =

Sumofpassingvertex + 1;

If next\_node = AMQD vertex distention

then node[i].sumofvertex =

SumofAMQD passingvertex;

**End for;**

End while;

It is distinct as the ratio of figure of data packets deliver to all the receivers to the number of data packets supposed to be delivered to the receivers. [1]

This ratio represents the routing effectiveness of the protocol:

$$\text{PDR} = \frac{\text{Packets delivered}}{\text{Packet Sent}}$$

**AVERAGE END-TO-END DELAY**

It is the average time taken for a data packet to move from the source to the receivers

$$\text{Avg. EED} = \frac{\text{Total EED}}{\text{No. of packets}}$$

**THROUGHPUT**

Throughput refers to how much data can be transferred from the source to the receiver(s) in a given amount of time

$$\text{Throughput} = \frac{\text{Number of packets sent}}{\text{Time Taken}}$$

**SIMULATION RESULTS AND ANALYSIS**

The performance of dissimilar Queue for VoIP application has been investigated via NS2 simulator. The non-payment parameter used in the simulation are listed in the bench

*Simulation parameters and values*

P a r a m e t e r s	V a l u e s
N u m b e r o f n o d e s	1 0
N e t w o r k s i z e	1 0 0 0 m * 1 0 0 0 m
M o b i l i t y	Placed in row an column based model
C o m m u n i c a t i o n m o d e l	Random way point model with continus movement
Placed in row an column based model	Selection by strict channel match 300m 6 0 0 s i m u l a t i o n s e c o n d s
M A C l a y e r	IEEE802.11 DCF with transmission rate of 12 Mbps for voice application
R o u t i n g	A O D V
C o d e c	G . 7 1 1 a n d G S M - E F R & G 7 2 3
T y p e o f s e r v i c e ( T O S )	I n t e r a c t i v e v o i c e , u n i c a s t
F r a m e s i z e	2 0 m s

Usually, MANETs are deliberate through simulation and their presentation depends a lot on the mobility model that governs the nodes movement. In the majority cases, the likelihood sharing of initial location and nodes speed differ from the sharing at later stage in the simulation. It is quite true, the likelihood distributions of both site and speed

varies incessantly over time, and meet to a *motionless* sharing. At any immediate throughout the simulation period, the sharing of site and speed is a weighted average of the initial sharing and the stationary sharing,[10][9]

In this model, each node is assign an initial location  $(x_0, y_0)$ , a destination  $(x_1, y_1)$ , and a velocity of  $S$ .

The point  $(x_0, y_0)$  and  $(x_1, y_1)$  are selected separately and consistently in the area of nodes group. The velocity is then chosen consistently on a time  $(v_0, v_1)$ , separately of both the initial site and purpose.

*Fig: 3 Functional flow of Random Point model*

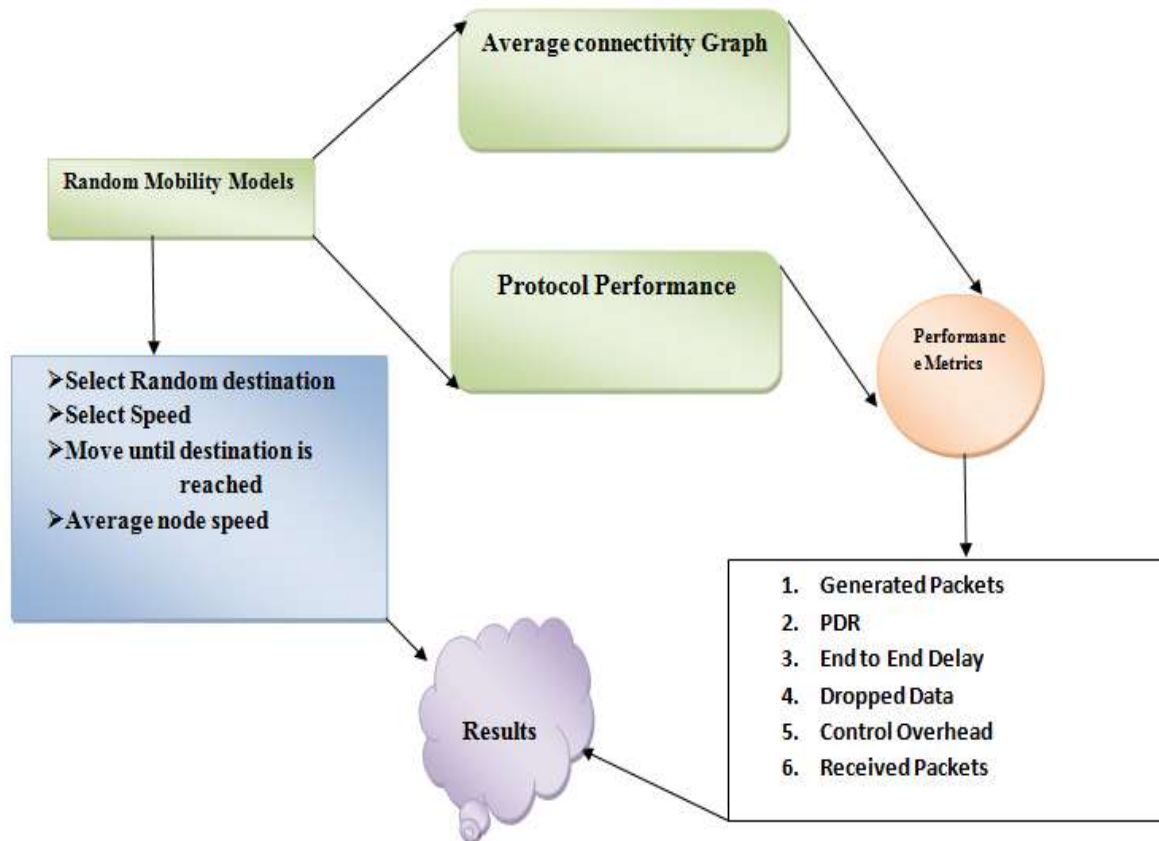

## RESULTS ANALYSIS

In this learn, the presentation of the MANET was evaluate by apply three types of queuing disciplines (DBPQ, IAE3 and CBCRTQ). Different MANET's parameter were tested and experiment to show the belongings of each of the queuing mechanisms on the MANET performance in codec. The optionalunreliable MANET's parameters are: number of nodes, nodes speed, pause times, and simulation areas. [23]

### NAM window in Network simulator

#### Throughput Analysis

As of the non-attendance setup, network throughput increases to anuppermost of 0.6 bit/sec more than midway the transmission time. However, angreat drop is also observed with increasing in the time of transmission. Change in encoding strategy does not influence this nature in any way, and the encryption characteristic does not form the situation any better. Changes in the MAC layer protocols also do not change the behavior. A highest throughput of 0.6bits/sec is still kept all the way.[2][1]



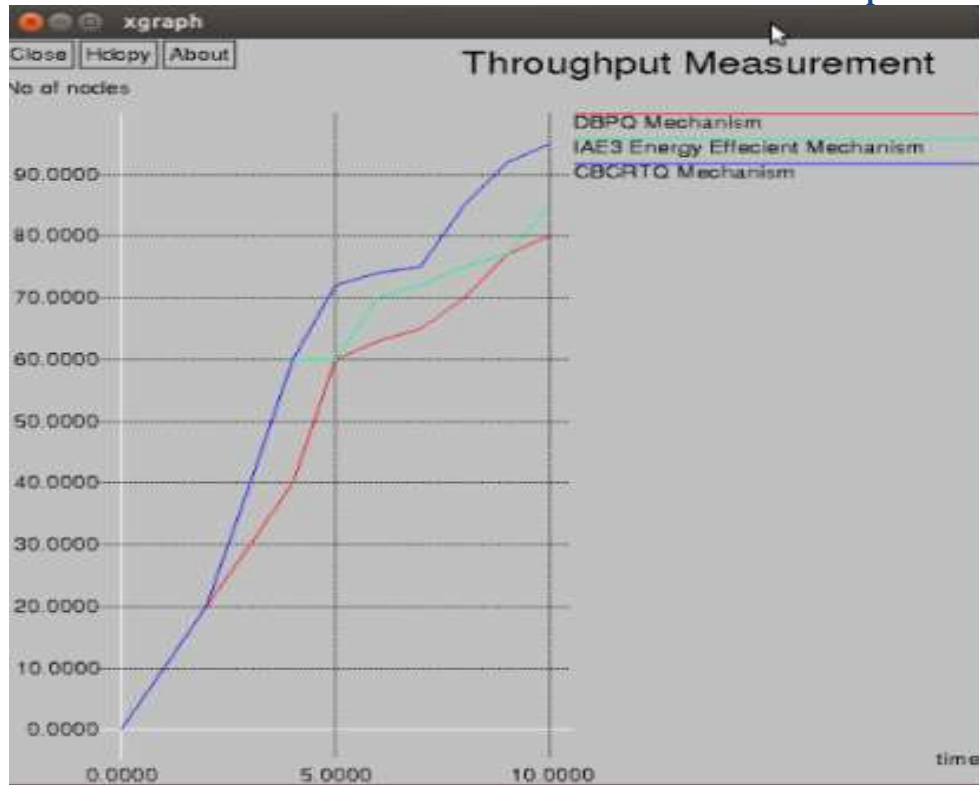

Fig:4 Multiple queuing Throughput measurement

#### Packet Delivery Ratio



Fig: 5 Multiple Queuing Packet Delivery ratio analysis

#### End to End Delay analysis

It is realize that end-to-end holdup of a system with node thicknessparameterbegin at about 40 seconds and increase to about 96 seconds with a less time of message. This remainsteady even with the modify in MAC layer protocols and (or) variations in encoding strategy.[5]

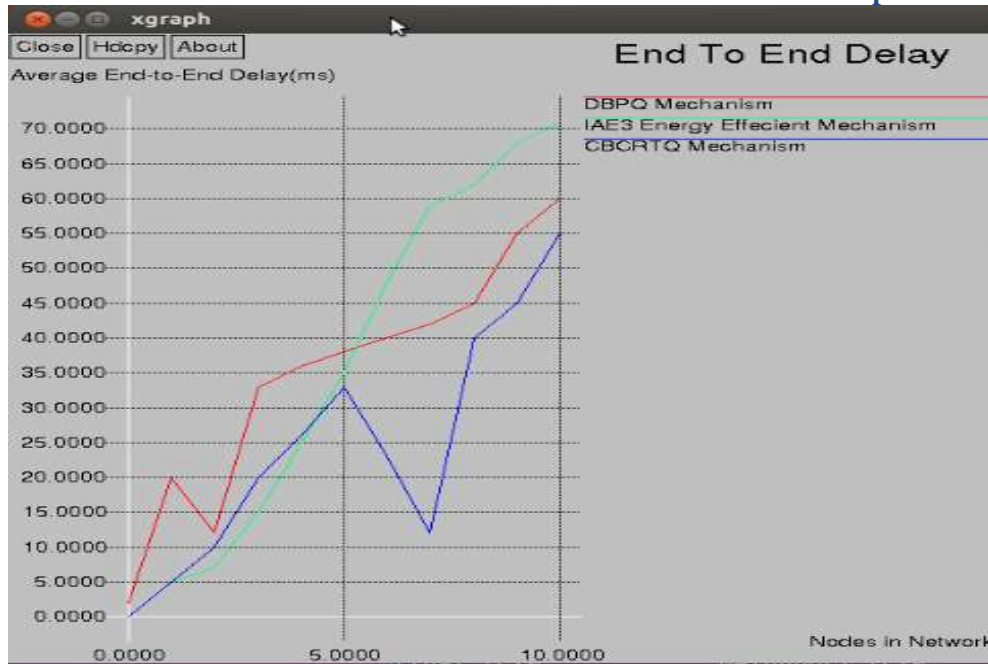

Fig: 6 multiple queuing End to End Delay analysis

### Jitter Analysis

The jitter of voice message in the MANET utilize AMQD routing methodology is less than 0.1sec as message time amplified and it at home its uppermost level between 75 to 85 seconds. This resource incessant communiqué MAC layer protocol also has no effect on voice jitter.[7]



Fig: 7 Multiple queuing Jitter analysis



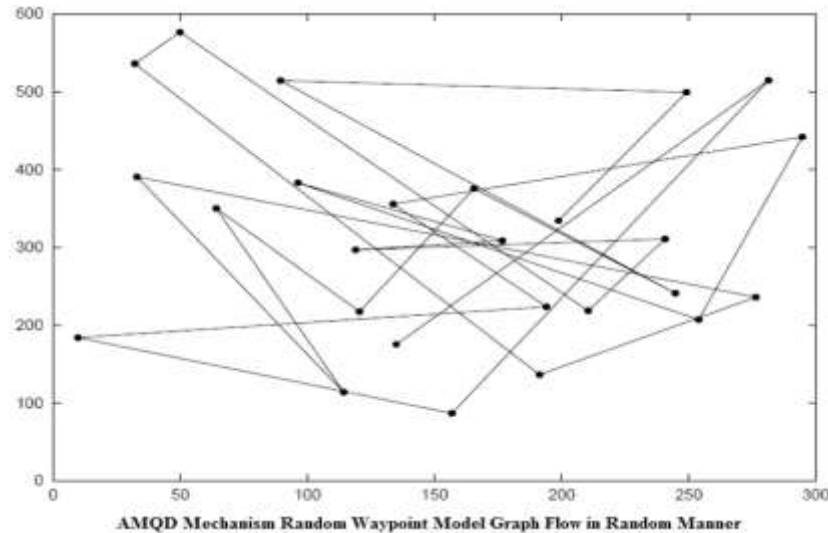

**Fig: 8 Random Waypoint Model**

The AMN (Adaptive Maximum node) is originally dispersed arbitrarily around the imitation area. The high unpredictability in average AMN neighbor proportion determination creates high unpredictability in presentation.

At the moment, three likely solutions to avoid this initialization difficulty. Put aside the site of the AMNs following a simulation has executed long. At first deal out the AMNs in a mode those maps to a sharing more ordinary to the model. Finally, discard the initial 1000 seconds of simulation time. A multifaceted association flanked by node speed and pause time. If the Random Waypoint Mobility replica is second-hand in a recital evaluation. [25][12]

## CONCLUSION

This research evaluates the presentation and performance of VoIP over MANET by applying AMQD mechanism under various voice codec schemes in Network simulation tool. A comparison has been conducted between two of voice codec scheme. This contrast meant to recognize which codec offer more acceptable presentation actions for request like VOIP. A choice which codec offers more acceptable presentation gauge results is only made depending on varying the number of users; the result shows a selection of G.711 and G723 codec in a simulation. And the configuration of Random waypoint model respectively algorithms performs better, achieving a lower discards rate and lower overall delay. This dissertation work minimizes end-to-end data transmission delay & average packet waiting time and increase overall throughput. Experimental results show that the proposed random packet scheduling scheme has better performance than the existing queuing.

## REFERENCE

- [1] Intelligent adaptive energy efficient & effective signal buffer management algorithm for voip (qos) over manet. M. Vijayakumar and V. karthikeyani International journal of future generation communication and networking 2016.
- [2] CBCRTQ Algorithm for Traffic Management In Voip Over MANET. M. Vijayakumar and V. karthikeyani International journal of future generation communication and networking 2016.
- [3] Nidal Nasser, Lutful Karim & Tarik Talib, "Dynamic Multilevel Priority Packet Scheduling Scheme for wireless sensor network", IEEE Trans on wireless communication, vol 12, NO. 4, April 2013.
- [4] G. Anastasi, M. Conti, and M. Di Francesco, "Extending the lifetime of wireless sensor networks through adaptive sleep," IEEE Trans. Industrial Informatics, vol. 5, no. 3, pp. 351–365, 2009.
- [5] G. Bergmann, M. Molnar, L. Goncezy, and B. Cousin, "Optimal period length for the CQS sensor network scheduling algorithm," in Proc. 2010 International Conf. Netw. Services, pp. 192–199.

- [6] E. Bulut and I. Korpeoglu, "DSSP: a dynamic sleep scheduling protocol for prolonging the lifetime of wireless sensor networks," in Proc. 2007 International Conf. Advanced Inf. Networking Appl., vol. 2, pp. 725–730.
- [7] S. Chachra and M. Marefat, "Distributed algorithms for sleep scheduling in wireless sensor networks," in Proc. 2006 IEEE International Conf. Robot. Autom., pp. 3101–3107.
- [8] P. Guo, T. Jiang, Q. Zhang, and K. Zhang, "Sleep scheduling for critical event monitoring in wireless sensor networks," IEEE Trans. Parallel Distrib. Syst., vol. 23, no. 2, pp. 345–352, Feb. 2012.
- [9] On the Evaluation of the Active Queue Management Mechanisms, Lukasz Chrost and Andrzej Chydzinski
- [10] Improving Quality of VoIP Streams over WiMax Shamik Sengupta, Student Member, IEEE, Mainak Chatterjee, and Samrat Ganguly IEEE TRANSACTIONS ON COMPUTERS, VOL. 57, NO. 2, FEBRUARY 2008.
- [11] Performance Studies of VoIP over Ethernet LANs Di Wu School of Computing and Mathematical Sciences, 2008.
- [12] D. Rizzetto, & C. Catania (1999). A Voice over IP Service Architecture for Integrated Communications. IEEE Internet Computing, Volume 3, Issue 3, Pages: 53 – 62.
- [13] PERFORMANCE ANALYSIS OF VOIP TRAFFIC OVER INTEGRATING WIRELESS LAN AND WAN USING DIFFERENT CODECS, Ali M. Alsahlany.
- [14] Floyd S., and Jacobson V. —Random Early Detection Gateways For Congestion Avoidance, IEEE/ACM Transactions on Networking, volume 1, issue 4, 1(4): pp. 397-413, August 1993.
- [15] Dow C R, Dow C R, Lin P J, et al, "A study of recent research trends and experimental guidelines in mobile ad-hoc network," Advanced Information Networking and Applications, P72-771, 2005.
- [16] T. Clausen, P. Jacquet, "Optimized Link State Routing Protocol", IETF RFC 3626, October 2003.
- [17] R Ogier, P. Spagnolo, "MANET Extension of OSPF using CDS Flooding, draft-ogier-manet-ospf-extension-06.txt, December 2005.
- [18] Perkins, C., Belding, E., Das, S., Ad hoc On-Demand Distance Vector (AODV) Routing - RFC 3561, 2003.
- [19] Bjorn Wiberg, "Porting AODV-UU Implementation to ns-2 and Enabling Trace-based Simulation", Master's Thesis, Dept. of Computer System, Uppsala University, Sweden, 18 Decber 2002
- [20] W. Ahn, "Gathering-based routing protocol in mobile ad hoc networks", Computer Communications 30 (2006) 202-206.
- [21] C. Tschudin, P. Gunningberg, H. Lundgren, and E. Nordstrom, "Lessons from Experimental MANET Research," Elsevier Ad Hoc Networks Journal, Vol. 3, Issue 3, March 2005.
- [22] Sanchez M, Manzoni P. A java-based ad hoc networks simulator. In Proceedings of the SCS Western Multi conference Web-based Simulation Track, January 1999.
- [23] Christian Bettstetter and Christian Wagner. The Spatial Node Distribution of the Random Waypoint Mobility Model. Proceeding Mobile Ad-Hoc Netwerke, 2002.
- [24] T. Camp, J. Boleng, and V. Davies A Survey of Mobility Models for Ad Hoc Network Research. Wireless Communication and Mobile Computing (WCWC): Special Issue on Mobile Ad Hoc Networking: Research, Trends, and Applications, vol. 2, no. 5, pp. 483-502, 2001.
- [25] C. Bettstetter, Smooth is better than sharp: a random mobility model for simulation of wireless networks, in: Proceedings of the ACM Workshop on Modeling, Analysis and Simulation of Wireless and Mobile Systems, 2001, pp. 19–27.
- [26] C. Bisdikian, An overview of the Bluetooth wireless technology, IEEE Communication Magazine, December 2001.
- [27] C. Bettstetter, O. Krause, On border effects in modeling and simulation of wireless ad hoc networks, in: Proceedings of the 3rd IEEE International Conference on Mobile and Wireless Communication Networks (MWCNM), 2001.