



[Patki*, 5(2): February, 2016]

ISSN: 2277-9655
(I2OR), Publication Impact Factor: 3.785

INTERNATIONAL JOURNAL OF ENGINEERING SCIENCES & RESEARCH TECHNOLOGY

ATMOSPHERIC CO₂ GAS AND TEMPERATURE MEASUREMENT ROBOT

Jyotishna J. Patki *, Prof. R. P. Chaudhari

*Govt. Engineering College, Aurangbad, India

ABSTRACT

In the age of industrial revolution the atmosphere is disturbed by the human acts one of which is the global warming, a major threat of this century. Thus in order to control these adverse effects an monitoring of atmospheric CO₂ and temperature robotic system is developed the system to collect data through various sensors. It gives a review of these systems based on existing technologies and also proposes an economical and generic automatic environment pollution control system based on wireless sensors with GSM for environment pollution control system controller and remote monitoring system. This system has simpler features of low cost and effective with less power consumption using sensors for remote monitoring and controlling devices which are controlled via SMS using a GSM module.

The system informs user about any abnormal conditions like temperature rise, even concentration of CO₂ via SMS from the GSM module to the higher authority mobile and actions are taken accordingly by the authority personnel. In future, the industry will be able to monitor and control the parameter by GSM technologies, and to provide safety and security for humans.

KEYWORDS: PIC 16F877A Microcontroller, LM35-Temperature Sensor, MQ7-Gas Sensor, MAX232, L293D Motor Driver, GSM Module

INTRODUCTION

The increase in the development of technology and the human race, we failed to take care about the surroundings in which we live in. Thus we polluted the environment and thereby reducing the quality of the place we live. Even though there are several aspects of pollution such as soil, air and water pollution, out of these air pollution acts as the serious aspect as the other can be detected visually and by taste, but the polluted air cannot be detected as it can be odourless, tasteless and colourless. Hence there is a growing demand for the environmental pollution monitoring and control Robotic systems.

The system proposed in this work measures carbon dioxide using a gas sensor of a semiconductor type based on tin dioxide (SnO₂) and is mainly a process of understanding the air quality to meet in one hand to a goal of miniaturization, low cost and portability, and it is a portable desktop instrument which measures carbon dioxide concentration and temp in air, within range of 20-2000 ppm and a resolution of 1ppm.

The LCD can display outputs concentration immediately in ppm. On the other hand to carry out either punctual measures in different places or to determine the temporal variations of a fixed site the concentration of carbon dioxide and temperature. This system offers two options for display: the first on an LCD display and the second via microcontroller via a MAX232 link. Considering the importance of temperature, its measurement is therefore incorporated into the measurement entity.

MATERIALS AND METHODS

PIC 16F877A

This is a CMOS FLASH based 8 bit, 40 pin microcontroller. It has five I/O ports. The PIC16F877A features 256 bytes of EEPROM data memory, self-programming, 2 Comparators, 8 channels of 10-bit Analog-to-Digital (A/D) converter, 2 capture/compare/PWM functions, the synchronous serial port can be configured as either 3-wire Serial Peripheral Interface or the 2-wire Inter-Integrated Circuit bus and a Universal Asynchronous Receiver Transmitter (USART). It works at an operating voltage range of 2V to 5V. The microcontroller calculates the number of units consumed based on the signal received from the IR sensor. The microcontroller has a USART module which provides a cost effective, simple and reliable communication between one

[http:// www.ijesrt.com](http://www.ijesrt.com)

© *International Journal of Engineering Sciences & Research Technology*

controller to another or between a controller and a PC. It also sends appropriate signal to the relay to connect or disconnect the load.

GSM Modem SIM800

GSM modem SIM800 is used to intimate the occurrence of over limit of toxic gases of CO₂ via SMS. Using GSM modem a predetermined message can be send to required authority so that they get alerted and reach the place quickly where situation occurred. GSM module is controlled by AT command.

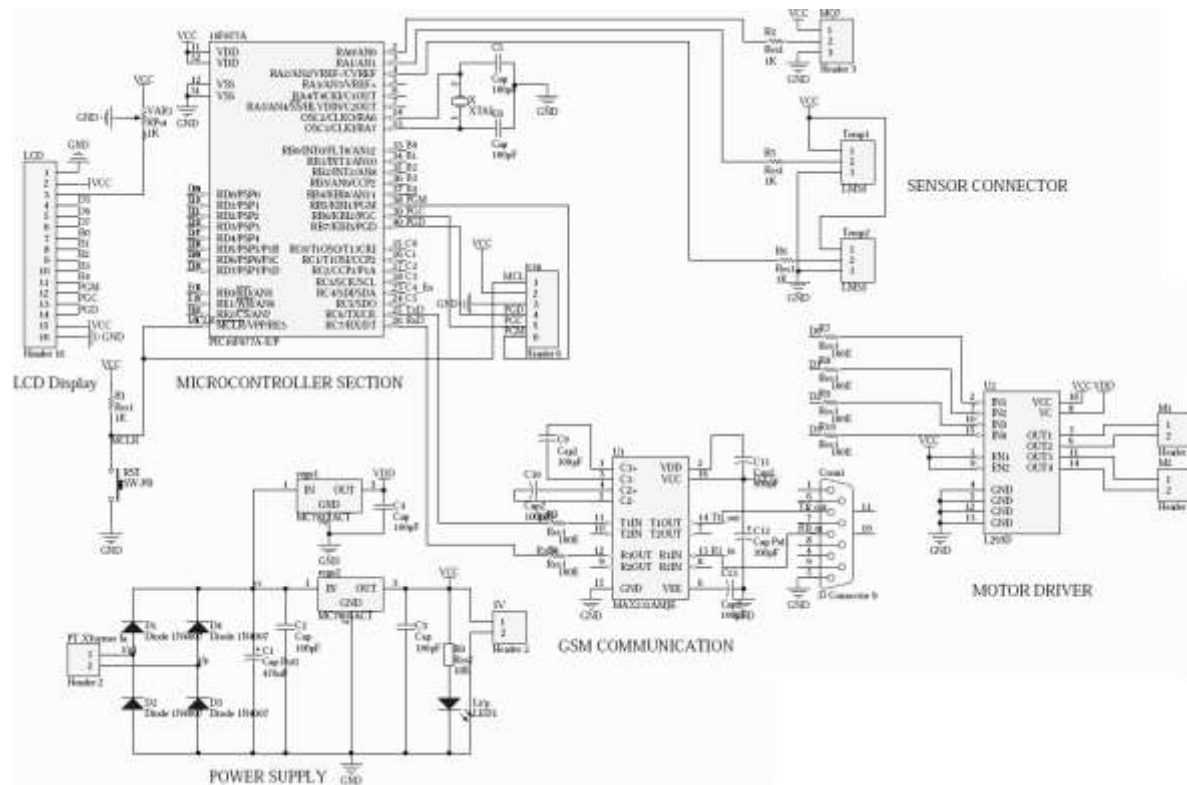

Fig.1. Circuit Diagram Atmospheric CO₂ Gas And Temperature Measurement Robot

This project is basically a robot which is used to measure the concentration of carbon dioxide (CO₂) and temperature in different environment and sending message through GSM to higher authority. For that we are using two temperature sensors (LM35) and CO₂ gas sensor (MQ7). For controlling our robot we are using PIC16F877A microcontroller. Whenever there is rise in temperature, output of temperature sensor changes accordingly input temperature and gives analog value in centigrade to controller. The output of temperature sensor changes at the rate of 10mv/degree centigrade. Similarly output of gas sensor changes the rate of 1.25mv/ppm. Both the sensor gives analog value to the controller as we are using PIC it is having inbuilt ADC. ADC first convert analog to digital value and sends data through serial communication via MAX232 to GSM.

GAS Sensor MQ7

This sensor is high sensitivity to carbon dioxide with stable and long life and they are used in gas detecting equipment for carbon dioxide (CO₂) in industry and automation also in vehicle and car. Structure and configuration of MQ-7 gas sensor composed by micro AL₂O₃ ceramic tube, Tin Dioxide (SnO₂) sensitive layer, measuring electrode and heater are fixed into a crust made by plastic and stainless steel net. The heater provides necessary work conditions for work of sensitive components. The enveloped MQ-7 has 6 pin, 4 of them are used to fetch signals, and other 2 are used for providing heating the current.

Table 1 The Motor Truth Table

| ENB | IN1 | IN2 | IN3 | IN4 | Description |
|-----|-----|-----|-----|-----|-----------------|
| 0 | 0 | 0 | 0 | 0 | Stop |
| 1 | 0 | 1 | 0 | 1 | Forward |
| 1 | 1 | 0 | 1 | 0 | Backward |
| 1 | 0 | 0 | 0 | 1 | Right Direction |
| 1 | 0 | 1 | 0 | 0 | Left Direction |

The given assembly is controlled displacement has achieved by the DC motors. The synchronized working of two motors is performing the operation of moving on X and Y axis with forward and backward direction. The X axis for the horizontal lines Y axis for the vertical lines which has achieved by combines functioning of two motors. By giving command through master (Mobile) of "FF" it will receive by GSM *i.e.* slave and move, similarly for "RR", "BB", "LL". We are giving "DD" for data receiving at master side (Authority).

RESULTS AND DISCUSSION

Experimental Results of Atmospheric CO₂ Gas and Temperature Measurement Robot as per samples are as shown in tables below.

Table 2 The Output Table of Measured Temperature and CO₂ in different medium

| Sr. No. | Medium | Temperature M E | | Gas (PPM) Standard | Gas (PPM) Average Measured | Present Content in Medium | % of CO ₂ |
|---------|------------------|-----------------|----|--------------------|----------------------------|---|----------------------|
| 1 | Laboratory | 23 | 24 | 400-500 | 397 | FECL ₃ , CO ₂ Thinner, NH ₃ | 99.45 |
| 2 | Smoke | 26 | 24 | >1500 | 1411 | NO ₂ , SO ₂ , H ₂ S, CO ₂ | 94.09 |
| 3 | Petrol Pump | 25 | 25 | >700 | 604 | CO, CO ₂ , N ₂ O | 86.4 |
| 4 | Flames | 45 | 44 | 500-700 | 438 | HEAT, LIGHT, Carbon, Smoke | 73.13 |
| 5 | Home Environment | 25 | 25 | 350-400 | 318 | O ₂ , CO ₂ , CO, LPG, N | 90.85 |
| 6 | Kitchen | 26 | 26 | <600 | 438 | LPG, O ₂ , CO ₂ | 73.10 |
| 7 | Square Point | 25 | 25 | >600 | 494 | O ₂ , CO ₂ , CO, N, SO ₂ | 82.36 |
| 8 | Bike Silencer | 25 | 25 | >1500 | 2285 | CO, CO ₂ | 152.37 |

Table are showing the readings of both sensor of various possible medium to calculate the percentage of gas in that medium for getting the results of different given parameter.

In the above table the samples of temperature and CO₂ have been taken. For considering the readings are taken in different Medium, and taken the readings for more accuracy for giving the output of the system and the result of Percentage of CO₂ is calculated. The Output Table of Calibrated Temperature and CO₂ in different medium in Percentage

CONCLUSION

By this system we can measure how the percentage of CO₂ is present in environment of different medium Industrial gas sensing and capturing in City of CO₂ pollution measurement. At the same time temperature is also measured.

Hence we get a very efficient PIC based controlled robot which will be very useful and gives a detailed mechanism of detection of temperature and CO₂ using Robot as well as send SMS through GSM to the authorised person. Such system helps human kind to work smoothly and comfortably in home, office or society for safety and security reasons.

REFERENCES

1. D. Bhattacharjee and R. Bera, "Development of Smart Detachable Wireless Sensing System for Environmental Monitoring" International Journal on Smart Sensing and Intelligent Systems *VOL. 7, NO. 3, SEPTEMBER 2014*
2. G. Michael Assistant Professor, Department of C.S.E, Bharath University, Chennai, TN, India, "An Efficient Interface for Monitoring Air Pollution by Using Micro-Controller Based Sensors" International Journal of Innovative Research in Computer and Communication Engineering *Vol. 1, Issue 3, May 2013*
3. P. Sushma Chowdary¹ and S. Aruna², "INFANT MONITORING SYSTEM" International Journal of Computer Science and Communication *Vol. 2, No. 2, July-December 2011*, pp. 501-503
4. Santhosh Kumar V1, Shanmuga Sundaram C2, Vasantha Kumar P3, Silambarasan K4, Sivasubramanian. K5 1, 2, 3, 4 B. E., Electronics & Communication, K. S. Rangasamy College of Technology, Tiruchengode, Namakkal, India Assistant Prof., Electronics & Comm., K. S. Rangasamy College of Technology, Tiruchengode, Namakkal, India, "Sensor network based dyeing industry Monitoring and Control System" International Journal Of Enhanced Research In Science Technology & Engineering *VOL. 2 ISSUE 2, FEB.-2013* ISSN NO: 2319-7463.
5. Anil. H. Sonune, S. M. Hambarde JSPM's Jayawantrao Sawant College of Engineering, E&TC Dept., Pune-28 2 E&TC Dept., JSPM, Pune, MH-India, "Monitoring and Controlling of Air Pollution Using Intelligent Control System" International Journal of Scientific Engineering and Technology ISSN: 2277-1581 *Volume No.4 Issue No5*, pp: 310-313 01 May. 2015
6. International Journal of Scientific Engineering and Technology ISSN: 2277-1581 *Volume No.4 Issue No5*, pp: 310-313 01 May. 2015, "Implementation of Microcontroller Based Wireless Scada System" International Journal of Science, Engineering and Technology Research (IJSETR), *Volume 3, Issue 4, April 2014*
7. Purnima, S. R. N. Reddy, PhD. Department of Electronics & Communication & Computer Science IGIT, GGSIP University, Delhi, India, "Design of Remote Monitoring and Control System with Automatic Irrigation System using GSM-Bluetooth" International Journal of Computer Applications (0975 – 888) *Volume 47– No.12, June 2012*
8. B. Rakesh Reddy Department of Electronics and Communications, KORM College of Engineering, Kadapa, 516001 Kadapa, India Affiliated to JNTU, Anantapur, 515001 Anantapur, India, "Online Monitoring Of Greenhouse Gases Leakage By Using Gsm" International Journal of Electronics and Communication Engineering & Technology (IJECET), ISSN 0976 – 6464(Print), ISSN 0976 – 6472(Online), *Volume 5, Issue 11, November (2014)*, pp. 25-32 © IAEME