

Resolving Multiple *Wh*-Fragments: A Syntax-Pragmatics Approach*

Sang-Hee Park

Department of English, Seoul National University,
599 Kwanangno, Kwanak-gu, Seoul
muse00@snu.ac.kr

Abstract. This paper attempts to provide a new analysis of multiple *wh*-fragments, the so-called ‘multiple sluicing’, in English. Against previous approaches which resort to a reconstruction/deletion account or a gapping analysis, the proposed analysis captures multiple *wh*-fragments without positing a copy-deletion mechanism. In fact, multiple *wh*-fragments are viewed as a root clause whose interpretation is determined by previous discourse context. This is achieved by suggesting a new type constraint based on the analysis of fragment by Bertomeu and Kordoni (2005).

Keywords: multiple *wh*-fragments, sluicing, context, resolution, HPSG

1 Introduction

Sluicing is a phenomenon which involves a stand alone *wh*-phrase whose content is partially determined by context.

- (1)a. A: Many dissidents have been released.
B: Do you know **who**?
b. A: Is there anyone who could possibly unscrew the hatch?
B: Gee, I wish I knew **who**.
c. A: Did anyone show up for class today?
B: Yup.
A: Really?
B: Yeah.
A: **Who**? (Ginzburg and Sag, 2000: 321-323)

In these examples, each of the reduced questions contains a single *wh*-phrase. However, similar examples with more than one *wh*-remnants are also possible.

- (2)a. A: Some student is reported to have quarreled with a famous professor.
B: [**Which student**] [**with which professor**]? (Ginzburg and Sag, 2000: 301)
b. Everyone bought something, but I can't tell you [**who**] [**what**].

The aim of this paper is to observe previous accounts on multiple *wh*-fragments shown in these examples, the so-called ‘Multiple Sluicing’ in English. It also attempts to provide an analysis in terms of pragmatic resolution based on Bertomeu and Kordoni (2005).

* I would like to thank three anonymous reviewers for comments and suggestions on the earlier version of this paper.

2 Previous Studies

2.1 Park and Kang's (2007) Multiple Sluicing Analysis

Sluicing is generally assumed to involve an ellipsis of a TP-constituent of a clause, leaving a CP-projection containing a *wh*-remnant. Sentences such as (3) are analyzed as involving movement of *who_i* into Spec of CP and subsequent deletion of the TP.

(3) Arabelle is marrying someone you know. Guess [CP *who_i* [~~TP she is marrying *t_i*]]!~~

However, this analysis cannot simply be extended to examples such as (2), because it would then give rise to a problem of having ungrammatical source.

(4) *Everyone bought something, but I can't tell you [**who**]_i [**what**]_j *t_i* bought *t_j*.

Despite this immediate problem, this kind of approach is pursued by Park and Kang (2007), who assume that examples such as (2) are 'genuine' multiple sluicing. In order to block the problem behind (4), Park and Kang adopt the movement theory of Richard (2001) and explain that the ungrammaticality of (4) is due to the ill-formed application of the copy-deletion operation. To be specific, it is assumed that the first *wh*-remnant is associated with the strong EPP feature, which determines which copy undergoes deletion. Thus, the tail of the first *wh*-remnant must be deleted and the head, i.e., the first *wh*-remnant itself should remain at overt syntax. On the other hand, in the case of the second *wh*-remnant, it is the tail which is associated with the strong EPP feature. Thus, what should remain after all are the head of the first chain and the tail of the second chain, represented as in (4'). This is the case we obtain the undeleted counterpart of (2b), *who bought what*.

(4') ..., but I can't tell you [**who**]_i [~~**what**~~]_j *t_i*-bought *t_j*

Let us turn to the case of (2b). Here, the tail of the second *wh*-remnant does not survive because it is included in the TP deletion site. Thus, the head survives instead and yields the surface form in (2b). In short, under Park and Kang's analysis, examples like (4) are simply nonexistent; either the string in (2b) or (4') is possible.

However, it is suspicious that multiple *wh*-fragments as well as sluicing involve *wh*-fronting. According to Ginzburg and Sag (2000), expressions such as *the hell* and *the heck* can only modify extracted *wh*-words.

- (5)a. A: A friend of mine came in.
B: **Who** (#the hell/#the heck)?
b. A: A friend of mine must have stepped in while I was out.
B: I wonder **who** (#the hell/#the heck). (Ginzburg and Sag, 2000: 314)
- (6)a. A: Some student is reported to have quarreled with a famous professor.
B: [**Who**](#the hell/#the heck) [**with who**]?
b. Everyone bought something, but I can't tell you [**who**](#the hell/#the heck) [**what**](#the hell/#the heck).

The fact that the modifiers *the hell* and *the heck* cannot appear in these examples is evidence against any analysis based on a reconstruction/deletion operation such as Park and Kang (2007).

Also, Park and Kang's copy-deletion analysis faces the problem of deciding which previous utterance can serve as the antecedent of the *wh*-remnants.¹ For example, in (7), the antecedent and the *wh*-remnants are separated by three turns of utterances.

- (7) A: Did anyone show up with any girl for the party yesterday?
 B: Yup.
 A: Really?
 B: Yeah.
 A: (Do you know) [**Who**] [**with who**]?

Moreover, as examples in (8) show, there are cases where possible antecedents for *wh*-remnants can only be provided by the following discourse context. In this case, there is no way to apply the copy-deletion operation.

- (8) a. I don't know [**who**] [**with who**], but I am sure everyone will get hooked up with someone.
 (Merchant, 2006: 286)
 b. I don't know [**who**] [**with who**], but I'm sure everybody will dance with somebody.
 (Romero, 1997:197)

These facts suggest that multiple *wh*-fragments cannot be analyzed by reconstruction/deletion based analysis.

2.2 A Gapping Analysis: Nishigauchi (1998) and Lasnik (2007)

Another way to explain multiple *wh*-fragments is to abandon the multiple sluicing analysis and to propose an alternative account: a gapping analysis (Nishigauchi, 1998; Lasnik, 2007). Lasnik argues that examples like (2) are special cases of gapping, with the initial *wh*-remnant in Spec of CP and the other in some other specifier position derived by rightward focus movement. As Park and Kang (2007) note, however, the second remnant of the multiple *wh*-fragments can be an element which cannot undergo rightward focus movement, such as the exceptionally Case-marked PP in (9b).

- (9) a. *I believe *t* to be dishonest [the politician with high profile in international affairs].
 b. One of the boys believes behind one of the trees to be the best place to hide, but I don't know [**which**] [**behind which tree**].

Moreover, multiple *wh*-fragments exhibit properties that can never be explained under this approach. First, multiple *wh*-fragments can appear in embedded environments.

- (10) a. Everyone brought something (different) to the potluck, but I couldn't tell you [**who**] [**what**].
 (Merchant, 2001:112)
 b. ?Some linguist criticized (yesterday) some paper about sluicing, but I don't know [**which linguist**] [**which paper about sluicing**].
 (Park and Kang, 2007: 422)

Note, however, that gapping is not possible in embedded context (Also noted by Takahashi, 1994; Nishigauchi, 1998; Park and Kang, 2007).

¹ Generally, the antecedent of the first *wh*-fragment has been considered to be a universal quantifier (Nishigauchi, 1998; Park and Kang, 2007, among others). However, it is doubtful whether this generalization is correct; in (2a) and (6a), the first *wh*-remnant involves an existential quantification, and in (7) the parallel element is *anyone*. Thus, I assume that the acceptability of multiple *wh*-fragments is basically not dependent on the nature of the quantification involved within the antecedent.

(11) *John saw Bill, and Tom said that Mary ~~saw~~ Susan.

Another fact that distinguishes the two constructions is the type of constituents involved. Multiple *wh*-fragments, as the term suggests, can only contain two *wh*-phrases. On the other hand, gapping can appear with both a *wh*- and a non-*wh* remnant.

- (12) a. I know who Mary talked to yesterday about phonology, ?*but I don't know [**who**]
[**about semantics**]. (Lasnik, 2007)
b. Which boy read Hamlet, and [**which girl**] read [**Macbeth**]? (Park and Kang, 2007)

Also, as we observed in (8), the fact that multiple *wh*-fragments can appear when followed by the parallel elements shows that they cannot be instances of gapping.

(13) *Peter ___ with Susie, and John danced with Elisabeth.

3 Theoretical Background

3.1 Fragment Analysis in HPSG

We observed in the previous section that neither a gapping analysis nor a reconstruction/deletion-based multiple sluicing analysis fails to explain the properties of multiple *wh*-fragments. Note, however, that we rejected the latter analysis because of the problem caused by the nature of the operation involved. This is important because the basic idea of treating sluicing and multiple *wh*-fragments as instances of a more general type is tenable given that both constructions involve stand alone *wh*-remnants whose semantics is associated with the same type of illocutionary force, *question*.

In terms of the Head-Driven Phrase Structure Grammar (HPSG), this means that multiple *wh*-fragments can be analyzed by extending the works of Ginzburg and Sag (2000) or of Bertomeu and Kordoni (2005). In both analyses, elliptical constructions such as sluicing and short answers are analyzed as fragments which are phrasal signs but whose semantics contain a *message*, i.e. the minimal independent unit of meaning. Fragments are resolved when they serve as proper answers or utterances to the questions, open issues or even to the surrounding physical environments. Since no reconstruction/deletion operation is involved, these analyses do not have the problem arise in Park and Kang's (2007) analysis.

In choosing one of the two analyses as theoretical background of this study, the differences between these analyses should be considered; first, in Ginzburg and Sag (2000), fragments are defined as head-daughters of the relevant clausal type (*declarative-fragment-clause* if it is a short answer, or *sluiced-fragment-clause* if it is a sluice), whereas in Bertomeu and Kordoni (2005), they are treated as non-head daughters. Thus, as Bertomeu and Kordoni point out, Ginzburg and Sag's analysis has a potential problem when the remnant of an elliptical construction involves more than one constituent, as in the case of multiple *wh*-fragments. Second, Ginzburg and Sag assume some syntactic parallelism between the source and the fragment. They capture this by requiring that the feature CAT(EGORY) of the remnant and that of the salient utterance to be the same. On the other hand, for Bertomeu and Kordoni, the effect of such a parallelism is a mere effect of an extension of SUBCATEGORIZATION PRINCIPLE, which requires that fragments must appear in the surface form corresponding to the semantic role they receive from the predicate at the semantic-conceptual level. The following example of German is an evidence showing that some kind of fragments do not have explicit linguistic source.

- (14) – Einen Kaffee, bitte.
 A coffee[acc. masc. sg.] please
 ‘A coffee, please.’

Considering these facts, I develop my analysis of multiple *wh*-fragments based on Bertomeu and Kordoni (2005).

3.2 Bertomeu and Kordoni (2005)

In Bertomeu and Kordoni (2005), two general ways of resolving various types of fragments are proposed: resolution via-identity, which takes place at the semantic-structural level and resolution via-inference, which takes place at the semantic-conceptual level. The first type finds its source in the previous source, as in (15a) and the second type finds two sources of context anchoring: the previous discourse (15b) and the surrounding physical environment (15c).

- (15) a. > When did 2-Pac release “All eyes on me”?
 > And Michael Jackson “Thriller”?
 b. > Has Anastacia released any CDs in the last year?
 - Yes, “Left outside alone”.
 > Any prizes?
 c. > Flights to Paris. (Uttered by a customer at the travel agency)
 (Bertomeu and Kordoni, 2005)

According to Bertomeu and Kordoni, in (15a), the structural information of the source of the gapped sentence is still in the ‘discourse-record’, which is a memory buffer that registers representations of the utterances in an order preserving way. In this case, the first utterance of (15a) can serve as the antecedent of the gapped sentence and thus resolution takes place at the semantic-structural level. However, there is no such direct linguistic source in (15b) and (15c). Yet, in (15b), resolution is still possible since there are representations of objects which are still under ‘focus of attention’.² That is, even though the structural information of the first utterance of (15b) cannot serve as antecedent, the objects being talked about at that point, i.e. the fact that Anastacia released some CDs last year, is active in the mental representations of the participants of this conversation, which is enough to resolve the fragment. In the last case (15c), ellipsis resolution depends on situational environments which trigger the activation of some script in the knowledge-base of the hearer.

Bertomeu and Kordoni propose the following new dimension, *res(olution)-type*, which classifies various types of fragments based on the way they are resolved. The subtype *sem(antic)-struct(ural)-res(olution)-frag(ment)-cl(ause)* represents cases such as (15a), where the resolution takes place at the semantic-structural level. This type also includes multiple *wh*-fragments, which always have a certain linguistic source. Another subtype *sem(antic)-conc(eptual)-res(olution)-frag(ment)-cl(ause)* represents fragments such as in (15b) and in (15c).

² The assumption behind this notion is that when a speaker chooses to utter fragments, it is because he believes that the focus of attention of the hearer and of himself are placed in the same mental representation, and thus, the hearer will be able to appreciate the meaning carried by fragments.

(16) *resolution-type* (Bertomeu and Kordoni, 2005)

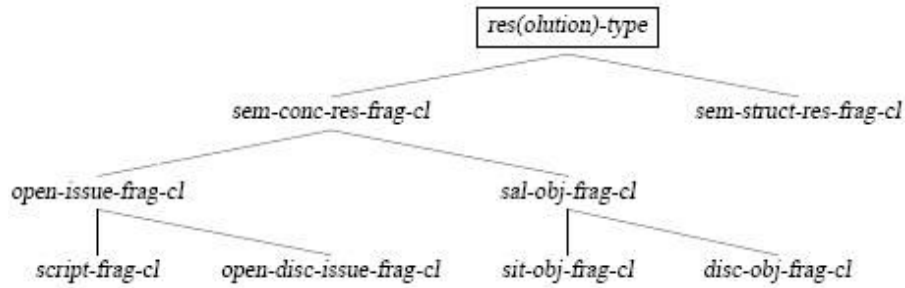

The specification for the type *sem-const-res-frag-cl* is shown in (17). This type contains information on the semantic-structural representation. The feature DISC-REC(ORD), which is a C(ON)T(E)XT feature, has as value an semantic-structural object of type *m(es)sage-cont(ent)-sem(antic)-obj(ect)*.³ The mother's REL(ATION)S list contain the RELS of the C-CONT and that of the NON-HEAD-DTRS. This means that the mother's meaning is composed from the meaning of its head and the non-head daughters. Also, the top-level semantics is provided by the head-daughter. This is achieved by identifying the L(OCAL)TOP of the C-CONT with GTOP.

(17) *sem-struct-res-frag-cl*:

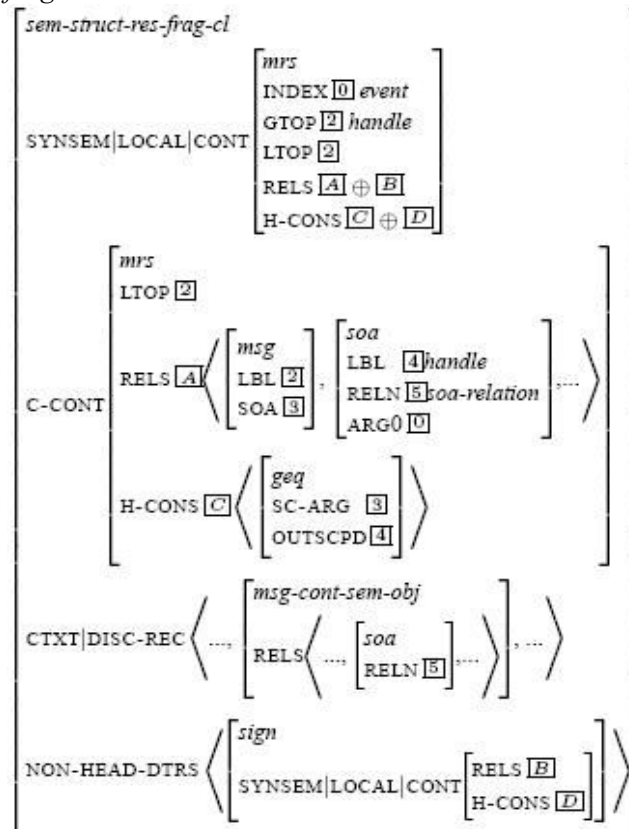

This type inherits from the following general type *frag(ment)-cl(ause)*, which specifies the syntax and deep semantics of fragments. The feature SEM stands for the semantic-conceptual

³ *msg-cont-sem-obj* is a subtype of *m(es)sage-cont(ent)-sem(antic)-obj(ect)* and *cont(ent)-sem(antic)-obj(ect)*, which are subtypes of a supertype *sem(antic)-obj(ect)*. These types represent semantic objects which serve as values of DISC-REC and FOC-ATT. For specifications of these types, please refer to Figure 1 of Bertomeu and Kordoni (2005).

representation and the feature C-SEM the relations that represent the meaning of the head-daughter.

(18) *frag-cl*:

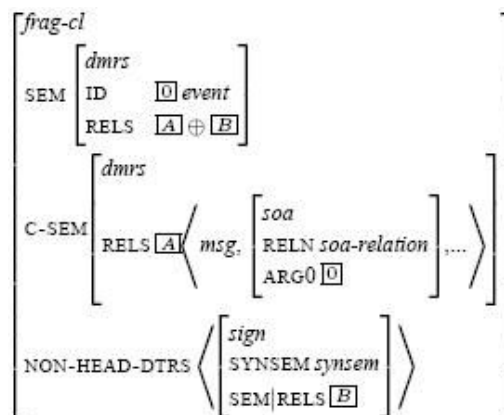

4 My Analysis

As I noted in section 3.1, under Bertomeu and Kordoni’s analysis, fragments are treated as non-head daughters in a general head-complement structure. The head-daughter is assumed as a phonetically empty element, which contributes its semantics to the mother. Thus, this analysis can account for fragments involving more than one constituent, such as constructions involving multiple *wh*-fragments.

Let us assume that Bertomeu and Kordoni’s analysis can be straightforwardly extended to multiple *wh*-fragments, that is, multiple *wh*-fragments are instances of the type *sem-struct-res-frag-cl*. Then, the two *wh*-remnants in this construction will correspond to NON-HEAD-DTRS, and the *soa* of C-CONT | RELS will carry the conceptual semantics of the verbal head which selects for these *wh*-remnants. The structure-sharing of RELN value between the *soa* within DISC-REC and the *soa* within C-CONT will ensure that the relation that the head-daughter provides is the same with the relation of the utterance in recent discourse context. In this way, the relationship between the fragments and their antecedent can be captured as far as the core meaning of the antecedent is present within the discourse record.

However, this approach is problematic because it captures multiple *wh*-fragments and gapping under the same type constraint.⁴ In order to correctly characterize these two constructions, constraints must be imposed independently on each case.

Below, I propose a new type for multiple *wh*-fragments, *multi(ple)-wh-frag(ment)-cl*, which is a subtype of the type *sem-struct-res-frag-cl* we observed in 3.2. Compared to this supertype, *multi-wh-frag-cl* further specifies at least the following facts; first, the type *multi(ple)-wh-frag(ment)-cl* must contain two *wh*-remnants. This is achieved by specifying the two members of the feature NON-H(EA)D-DTRS to contain an element of type *param*, which represents the quantificational meaning of a *wh*-expression, within the feature STORE. Second, the STORE value of the mother is empty, which means that the stored meaning of *wh*-expressions must be retrieved at this node. Also, this constraint requires that the non-head daughters’ WH value be empty, since no extraction is involved.

⁴ Note that the gapping example in (15a) is assumed as an instance of this type in Bertomeu and Kordoni (2005).

(19) *multi-wh-frag-cl*:

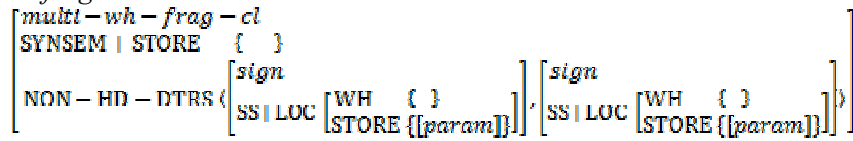

(20) *multi-wh-frag-cl* (inherited from supertypes)

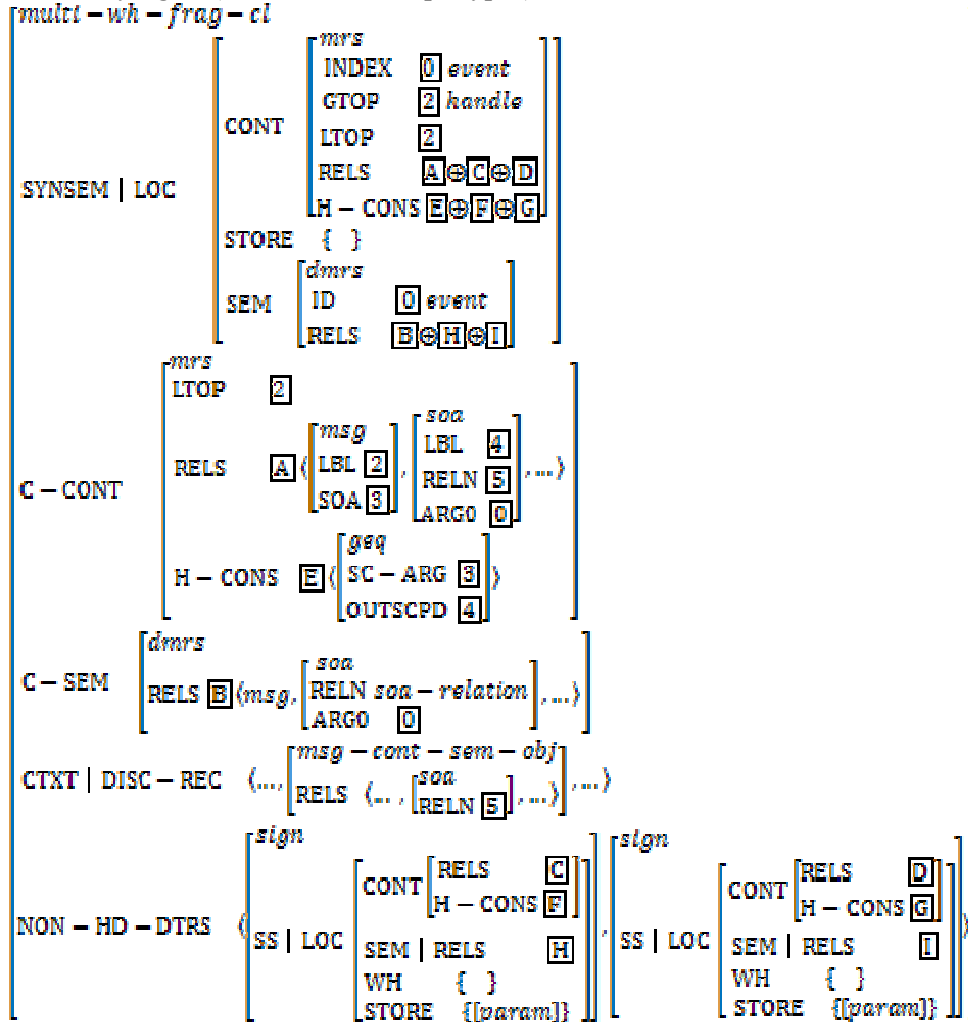

The examples of multiple *wh*-remnants observed in this paper are all correctly licensed by this constraint, except the examples in (8) I repeat below.

- (21) a. I don't know [**who**] [**with who**], but I am sure everyone will get hooked up with someone.
 b. I don't know [**who**] [**with who**], but I'm sure everybody will dance with somebody.

In this case, there is no predicate that can serve as the head of the multiple *wh*-fragments because the corresponding element does not enter the discourse-record until *who with who* is spoken. Rather, it is provided right after the fragments are spoken. Thus, it seems that the element corresponding to the relation tagged with $\boxed{5}$ in (20) is empty until the fragments are spoken and then later filled when the following utterance provides the corresponding predicate. To implement this idea, a modified notion of discourse-record is needed, which, at this moment, I leave to future research.

Also, as noted by Nishigauchi (1998), the distribution of embedded examples such as (2b), repeated here as (22a), is restricted to cases where they appear as a complement of factive/resolutive predicates such as *know*, *discover*, *forget*, *tell*, *guess*, *predict*. Multiple *wh*-fragments strongly resist appearing as a complement of Question Embedding (QE) predicates⁵ such as *ask*, *wonder*, *investigate*, and *discuss*.

- (21) a. Everyone bought something, but I can't tell you [**who**] [**what**].
b. Everyone bought something. *?I wonder [**who**] [**what**]. (Nishigauchi, 1998: 146)

Assuming Ginzburg and Sag's (2000) accounts on these predicates, it seems that the preference for factive/resolutive predicates comes from the fact that these predicates do not simply take questions as their argument, but rather coerce the question into a fact. At the moment, my best approximation is that the goal of speaking multiple *wh*-fragments in a conversation is not to ask the hearer about the referents of the *wh*-expressions, but to assert a fact about the previously uttered proposition e.g. that he knows or does not know who they really are. Though I do not provide a detailed analysis of this issue, the (im)possibility of embedding with certain predicates can be captured by refining the lexical entries of predicates which take a sentential complement whose content is type *question*.

5 Conclusion

In this paper, I proposed an alternative analysis of multiple *wh*-fragments. I suggested that the resolution of multiple *wh*-fragments is, to some extent, determined by discourse context. Further research is required to explain the narrower distribution of embedded cases and the fact that the source can be provided right after multiple *wh*-fragments are uttered.

References

- Bolinger, D. 1978. Asking more than one Thing at a Time. In H. Hiz, ed., *Questions*, pp. 107-150. Dordrecht: Reidel.
- Bertomeu, N. and V. Kordoni. 2005. Integrating Pragmatic Information in Grammar. An Analysis of Intersentential Ellipsis. In S. Müller, ed., *Proceedings of the HPSG05 Conference*.
- Ginzburg, J. and I. A. Sag. 2000. *Interrogative Investigations: The Form, Meaning, and Use of English Interrogatives*. Stanford: CSLI.
- Lasnik, H. 2007. Multiple Sluicing. A handout given in *LING 819 Spring 2007*. University of Maryland.
- Merchant, J. 2001. *The Syntax of Silence: Sluicing, Islands, and the Theory of Ellipsis*. Oxford.
- Nishigauchi, T. 1998. 'Multiple Sluicing' in Japanese and the Functional Nature of *Wh*-Phrases. *Journal of East Asian Linguistics*, 7, pp. 121-152.
- Park, M.-K. and J.-M. Kang. 2007. Some Remarks on Multiple Sluicing in English. *Studies in Generative Grammar*, 17(1), pp. 419-434.
- Richard, N. 2001. *Movement in Language*. Oxford: Oxford University Press.
- Romero, M. 1997. Recoverability Conditions for Sluicing. In F. Corblin *et al.*, eds., *Empirical Issues in Formal Syntax and Semantics*. pp. 193-216. Peter Lang: Bern.
- Takahashi, D. 1994. Sluicing in Japanese. *Journal of East Asian Linguistics*, 3, pp. 263-300.

⁵ This term is adopted from Ginzburg and Sag (2000).