

# 1.4 Optimization of an orthogonally stiffened plate considering fatigue constraints

Luis M.C. Simões<sup>1</sup>, József Farkas<sup>2</sup> and Karoly Jarmai<sup>2</sup>

<sup>1</sup>University of Coimbra, Portugal, [lcsimoes@dec.uc.pt](mailto:lcsimoes@dec.uc.pt)

<sup>2</sup>University of Miskolc, Hungary, [altjar@uni-miskolc.hu](mailto:altjar@uni-miskolc.hu)

Abstract

The aim of this work is the optimization of a uniaxially compressed stiffened plate subjected to static and fatigue loading. The design variables are the thickness of the base plate, the number and stiffeners of the orthogonally stiffened plate. The constraints deal with the static overall plate buckling, the stiffener failure and the fatigue strength of the welded connections between the stiffeners and the interaction of the two types of failure. The cost function includes the cost of material, assembly, welding and painting. Randomness is considered both in loading and material properties. A level II reliability method (FORM) is employed. The overall structural reliability is obtained by using Ditlevsen method of conditional bounding. The costs of the plate designed to ensure a stipulated probability of failure will be compared with the solutions obtained for a code based method, which employs partial safety factors.

Keywords: reliability-based optimization, stiffened plates, fatigue

## 1. Introduction

Stiffened plates are often the main structural components of load-carrying structures such as bridges, columns, towers, platforms, vehicles etc. The aim of this work is the optimization of a uniaxially compressed stiffened plate. The thickness of the base plate as well as the numbers and dimensions of the longitudinal and transverse stiffeners are sought, which fulfil the design and fabrication constraints and minimize the cost function. The constraints relate to the static overall plate buckling, to the stiffener induced failure and to the fatigue strength of welded connections between the stiffeners. Interaction of the two types of failure, buckling and fatigue can be more dangerous than each individually: the fatigue crack propagation might affect the development of buckling.

The buckling constraints are formulated according to the Det Norske Veritas design rules, the fatigue strength constraint is expressed using the data of Eurocode 3. The fabrication constraints limit the maximal number of stiffeners in one direction to ensure the welding of welds connecting the stiffeners to the base plate. The cost function includes the cost of material, assembly, welding and painting and is formulated according to Farkas, J., Jarmai, K. (2003).

Stresses and displacements can be computed given the deterministic parameters of loads, geometry and material behaviour. Some structural codes specify a maximum probability of failure within a given reference period (lifetime of the structure). This probability of failure is ideally translated into partial safety factors and combination factors by which variables like strength and load have to be divided or multiplied to find the so called design values. The structure is supposed to have met the reliability requirements when the limit states are not exceeded. The advantage of code type level I method (using partial safety factors out of codes) is that the limit states are to be checked for only a small number of combinations of variables. The safety factors

are often derived for components of the structure disregarding the system behaviour. The disadvantage is lack of accuracy. This problem can be overcome by using more sophisticated reliability methods such as level II (first order second order reliability method, FOSM [4] and level III (Monte Carlo) reliability methods. In this work FOSM was used and the sensitivity information was obtained analytically. Besides stipulating maximum probabilities of failure for the individual modes, the overall probability of failure which account for the interaction by correlating the modes of failure is considered.

A branch and bound strategy coupled with an entropy-based algorithm is used to solve the reliability-based optimization. The entropy-based procedure is employed to find optimum continuous design variables giving lower bounds on the decision tree and the discrete solutions are found by implicit enumeration. Results are given comparing deterministic and reliability-based solutions and show how the optimum solution changes with the axial force and loading amplitude used to describe fatigue.

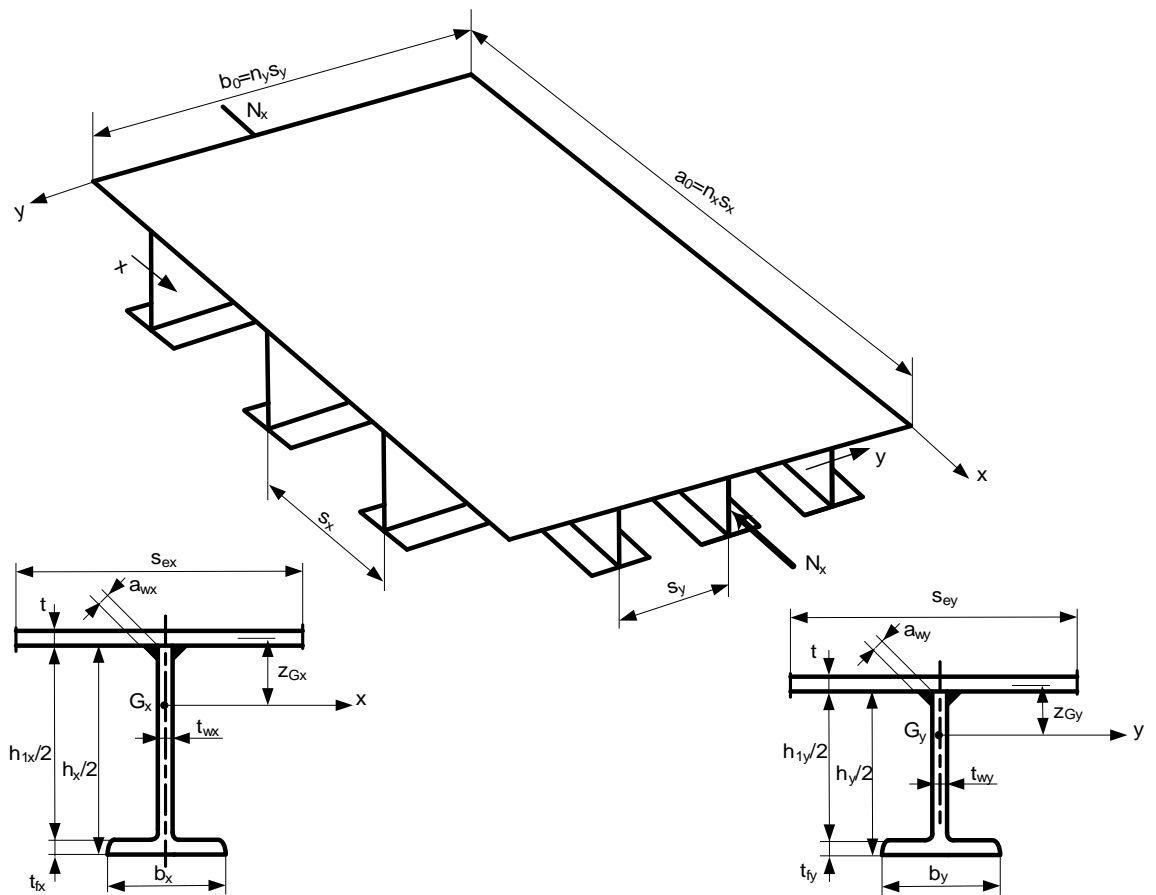

Figure 1. Orthogonally stiffened plate loaded by uniaxial compression

## 2. Design variables

The design variables are the base plate thickness  $t$ , sizes and number of stiffeners in both directions:  $h_y, h_x, n_y, n_x$ .

Ranges of unknowns:  $4 < t < 20$  mm,  $152 < h < 1016$  mm,  $4 < n < n_{max}$ . The maximum values of  $n_i$  is given by the fabrication constraints Eq. (1).

$$\frac{b_0}{n_y} - b_y \geq 300 \text{ mm}, \quad \frac{a_0}{n_x} - b_x \geq 300 \text{ mm}. \quad (1)$$

### 3 Constraints

3.1 Overall buckling constraint according to DNV

$$\sigma = \frac{N_x}{n_y A_{ey}} \leq \sigma_{cr} = \frac{f_{y1}}{\sqrt{1 + \lambda^4}}, \quad f_{y1} = \frac{f_y}{1.1} \quad (2)$$

$$\lambda = \sqrt{\frac{f_{y1}}{\sigma_E}}, \quad \sigma_E = \frac{N_E s_y}{A_{ey}}, \quad N_E = \frac{\pi^2}{b_0^2} \left( B_x \frac{b_0^2}{a_0^2} + B_y \frac{a_0^2}{b_0^2} \right) \quad (3)$$

It can be seen from the load-carrying capacity formula  $N_E$  that, when  $a_0 > b_0$ , to have a larger  $N_E$ ,  $B_x$  ( $h_x$ ) should be larger than  $B_y$  ( $h_y$ ). From the theoretical buckling strength  $\sigma_E$  the critical strength  $\sigma_{cr}$  is calculated by using a slenderness  $\lambda$  to take into account the effect of initial imperfections. The factored compressive force is calculated as

$$N_x = \gamma_{stat} N_{xstat} + \gamma_F \Delta N / 2, \quad (4)$$

where  $\gamma_{stat} = 1.1$  and  $\gamma_F = 1.35$  are safety factors,  $N_{xstat}$  is the static component and a variable component has an amplitude of  $\Delta N / 2$ .

3.2 Constraint on stiffener torsional buckling according to DNV

The constraint is formulated as

$$\sigma_1 = \frac{N_x}{n_y A_{ey1}} \leq \sigma_{acr} = \frac{\sigma_k}{\phi + \sqrt{\phi^2 - \lambda_S^2}} \quad (5)$$

3.3 Constraint on fatigue strength of welded connections of stiffeners

The constraint on fatigue strength is defined by

$$\alpha_0 \frac{\Delta N}{n_y A_{ey}} \leq \frac{\Delta \sigma_N}{\gamma_{Mf}} \quad (6)$$

where  $\alpha_0$  is the interaction factor to avoid the danger of interaction of the buckling and fatigue phenomena,  $\Delta N$  is the variable load range,  $\Delta \sigma_N$  is the fatigue stress range corresponding to the number of cycles  $N_C$ ,  $\gamma_{Mf}$  is the safety factor for fatigue.

### 4. Cost function

The cost function includes the cost of material, assembly, welding as well as painting and is formulated according to the fabrication sequence.

The cost of material

$$K_M = k_M \rho V_2; k_M = 1.0 \text{ \$/kg}. \quad (7)$$

Welding of the base plate from butt welds (3 in direction of  $a_0$  and 3 in direction of  $b_0$ ) (SAW - submerged arc welding) Farkas, J., Jármai, K. (2007):

The fabrication cost factor is taken as  $k_F = 1.0$  \\$/min, the factor of complexity of the assembly  $\Theta_W = 2$ :

$$K_0 = k_F \left[ \Theta_W \sqrt{16\rho V_0} + 1.3C_W t^n (3a_0 + 3b_0) \right], \quad (8)$$

Welding  $(n_x-1)$  stiffeners to the base plate in  $y$  direction with double fillet welds (GMAW-C - gas metal arc welding with  $\text{CO}_2$ ):

$$K_{W1} = k_F \left[ \Theta_W \sqrt{n_x \rho V_1} + 1.3 \times 0.3394 \times 10^{-3} a_{wx}^2 2b_0 (n_x - 1) \right] \quad (9)$$

Welding of  $(n_y - 1)$  stiffeners to the base plate in  $x$  direction with double fillet welds. These stiffeners should be interrupted and welded with fillet welds to the stiffeners in the  $y$  direction.

$$K_{W2} = k_F \left[ \Theta_W \sqrt{(n_y n_x - n_x + 1) \rho V_2} + 1.3 \times 0.3394 \times 10^{-3} a_{wy}^2 2a_0 (n_y - 1) + T_1 \right] \quad (10)$$

which is rounded to  $0.4t_{wy}$ .

Painting

$$K_P = k_P \Theta_P S_P \quad (11)$$

$$k_P = 14.4 \times 10^{-6} \text{ \$/mm}^2, \quad \Theta_P = 2,$$

Surface to be painted

$$S_P = 2a_0 b_0 + a_0 (n_y - 1)(h_{Ly} + 2b_y) + b_0 (n_x - 1)(h_{Lx} + 2b_x) \quad (12)$$

The total cost

$$K = K_M + K_0 + K_{W1} + K_{W2} + K_P \quad (13)$$

## 5. Reliability-based optimization

A failure event may be described by a functional relation, the limit state function, in the following way

$$F = \{g(\underline{x}) \leq 0\} \quad (14)$$

In the case the limit state function  $g(\underline{x})$  is a linear function of the normally distributed basic random variables  $\underline{x}$  the probability of failure can be written in terms of the linear safety margin  $M$  as:

$$P_F = P\{g(\underline{x}) \leq 0\} = P(M \leq 0) \quad (15)$$

which reduces to the evaluation of the standard normal distribution function

$$P_F = \Phi(-\beta) \quad (16)$$

where  $\beta$  is the reliability index given as

$$\beta = \mu_M / \sigma_M \quad (17)$$

The reliability index has the geometrical interpretation as the smallest distance from the line (or the hyperplane) forming the boundary between the safe domain and the failure domain. The evaluation of the probability of failure reduces to simple evaluations in terms of mean values and standard deviations of the basic random variables.

When the limit state function is not linear in the random variables  $\underline{x}$ , the linearization of the limit state function in the design point of the failure surface represented in normalised space  $\underline{u}$ . was proposed in Hasofer, A.M. & Lind, N.C. (1974),

$$u_i = (x_i - \mu_{x_i}) / \sigma_{x_i} \quad (18)$$

As one does not know the design point in advance, this has to be found iteratively in a number of different ways. Provided that the limit state function is differentiable, the following simple iteration scheme may be followed:

$$\alpha_i = -\partial g(\beta \alpha) / \partial u_i \left[ \sum_{j=1}^n \partial g(\beta \alpha)^2 / \partial u_j \right] \quad (19)$$

$$G(\beta\alpha_1, \beta\alpha_2, \dots, \beta\alpha_v) \quad (20)$$

which will provide the design point  $\underline{u}^*$  as well as the reliability index  $\beta$ .

The reliability assessment requires an enumeration of the reliability indices associated with limit state functions to evaluate the structural system probability of failure. Collapse modes are usually correlated through loading and resistances. For this reason, several investigators considered this problem by finding bounds for  $p_F$ . By taking into account the probabilities of joint failure events such as  $P(F_i \cap F_j)$  which means the probability that both events  $F_i$  and  $F_j$  will simultaneously occur. The resulting closed-form solutions for the lower and upper bounds are as follows:

$$p_F \geq (F_1) + \sum_{i=2}^m \text{Max} \left\{ \left[ P(F_i) - \sum_{j=1}^{i-1} P(F_i \cap F_j) \right]; 0 \right\} \quad (21)$$

$$p_F \leq \sum_{i=1}^m P(F_i) - \sum_{i=2}^m \text{Max}_{j < i} P(F_i \cap F_j) \quad (22)$$

The above bounds can be further approximated using Ditlevsen (1979) method of conditional bounding [10] to find the probabilities of the joint events. This is accomplished by using a Gaussian distribution space in which it is always possible to determine three numbers  $\beta_1, \beta_2$  and the correlation coefficient  $\rho_{ij}$  for each pair of collapse modes  $F_i$  and  $F_j$  such that if  $\rho_{ij} > 0$  ( $F_i$  and  $F_j$  positively correlated):

$$P(F_i \cap F_j) \geq \text{Max} \left\{ \Phi(-\beta_j) \Phi\left(-\frac{\beta_i - \beta_j \rho_{ij}}{\sqrt{1 - \rho_{ij}^2}}\right); \Phi(-\beta_i) \Phi\left(-\frac{\beta_j - \beta_i \rho_{ij}}{\sqrt{1 - \rho_{ij}^2}}\right) \right\} \quad (23)$$

$$P(F_i \cap F_j) \leq \Phi(-\beta_j) \Phi\left(-\frac{\beta_i - \beta_j \rho_{ij}}{\sqrt{1 - \rho_{ij}^2}}\right) + \Phi(-\beta_i) \Phi\left(-\frac{\beta_j - \beta_i \rho_{ij}}{\sqrt{1 - \rho_{ij}^2}}\right) \quad (24)$$

In which  $\beta_i$  and  $\beta_j$  are the safety indices of the  $i$ th and the  $j$ th failure mode and  $\Phi[ ]$  is the standardized normal probability distribution function.

The probabilities of the joint events  $P(F_i \cap F_j)$  in (8) and (9) are then approximated by the appropriate sides of (23) and (24). For example, if  $F_i$  and  $F_j$  are positively dependent for the lower (21) and upper (22) bounds it is necessary to use the approximations given by the upper (24) and lower (23) bounds, respectively.

## 6. Optimization Strategy

### 6.1 Branch and Bound

The problem is non-linear and the design variables are discrete. Given the small number of discrete design variables an implicit branch and bound strategy was adopted to find the least cost solution. The two main ingredients are a combinatorial tree with appropriately defined nodes and some upper and lower bounds to the optimum solution associated the nodes of the tree. It is then possible to eliminate a large number of potential solutions without evaluating them.

Three levels were considered in the combinatorial tree. The plate thickness is fixed at the top of the tree, the remaining levels corresponding to  $n_x$  (and the appropriate UB profile  $h_x$ ) and  $n_y$  associated with  $h_y$ . A strong branching rule was employed. Each node can be branched into  $n_s$  new nodes, each of these being associated with the number of stiffeners needed in the  $x$  direction. This requires using continuous values close to the geometric characteristics of an UB section,  $(A_s, b, t_f, t_w)$ , which are

approximated by curve-fitting functions written as a function of  $h$ . The stiffener height is also obtained from a curve fitting of the heights  $h$ . Care has to be taken to find geometrical properties leading to convex underestimates of the actual UB section, so that the solution obtained by using the real UB geometric characteristics is more costly than the solution given by using continuous approximations. In the second level of the tree the branches correspond to different stiffener UB profiles. At the third level the resulting minimum discrete solution becomes the incumbent solution (upper bound). Any leaf of the tree whose bound is strictly less than the incumbent is active. Otherwise it is designated as terminated and need not to be considered further. The B&B tree is developed until every leaf is terminated. The branching strategy adopted was breadth first, consisting of choosing the node with the lower bound.

## 6.2 Optimum design with continuous design variables

For solving each relaxed problem with continuous design variables the simultaneous minimization of the cost and constraints is sought. All these goals are cast in a normalized form. For the sake of simplicity, the goals and variables described in the following deal with stiffened shells. If a reference cost  $K_0$  is specified, this goal can be written in the form,

$$g_1(t, n, h) = K(t, n, h) / K_0 - 1 \leq 0 \quad (25)$$

Another two goals arise from the constraint on overall buckling and single panel buckling:

$$g_3(t, n, h) = \sigma_c / \sigma_{cr} - 1 \leq 0 \quad (26)$$

$$g_2(t, n, h) = \sigma_t / \sigma_{acr} - 1 \leq 0 \quad (26)$$

The remaining goal deals with the fatigue strength of the stiffeners connections:

$$g_4(t, h) = \Delta\sigma / \Delta\sigma_n - 1 \leq 0 \quad (28)$$

The objective of this Pareto optimization is to obtain an unbiased improvement of the current design, which can be found by the unconstrained minimization of the convex scalar function Simões, L.M.C. & Templeman, A.B.(1989):

$$F(t, h) = \frac{1}{\rho} \cdot \ln \left[ \sum_{j=1}^3 \exp \rho(g_j(t, h)) \right] \quad (29)$$

This form leads to a convex conservative approximation of the objective and constraint boundaries. Accuracy increases with  $\rho$ .

The strategy adopted was an iterative sequence of explicit approximation models, formulated by taking Taylor series approximations of all the goals truncated after the linear term. This gives:

$$\text{Min } F(t, h) = \frac{1}{\rho} \cdot \ln \left[ \sum_{j=1}^3 \exp \rho \left( g_{0j}(t, h) + \frac{\partial g_{0j}(t, h)}{\partial t} dt + \frac{\partial g_{0j}(t, h)}{\partial h} dh \right) \right] \quad (30)$$

This problem has an analytic solution giving the design variables changes  $dt$  and  $dh$ . Solving for a particular numerical value of  $g_{0j}$  forms an iteration of the solution to problem (30). Move limits must be imposed on the design variable changes to guarantee the accuracy of the approximations. Given the small number of design variables an analytic solution is available. During the iterations the control parameter  $\rho$ , which should not be decreased to produce an improved solution, is increased.

## 5. Numerical Examples

Numerical data (Figure 1):  $a_0 = 24000$ ,  $b_0 = 8000$  mm, steel yield stress  $f_y = 355$  MPa, elastic modulus  $E = 2.1 \times 10^5$  MPa, shear modulus  $G = 0.8 \times 10^5$ , density  $\rho = 7.85 \times 10^{-6}$  kg/mm<sup>3</sup>, selected rolled I-sections UB profiles. Consistent with the traditional limit state design (level 1 approach), the following solutions consider a deterministic behaviour of all the variables for several load combinations of the original compressive force  $N_{xstat}$  and the load range for fatigue  $\Delta N$ .

	$N_{xstat}$	$\Delta N$	$h_x$	$h_y$	$t$	$n_x$	$n_y$	<i>Cost</i>
1	$2 \times 10^7$	$6 \times 10^6$	403.2	257.2	13	6	19	54198
2	$3 \times 10^7$	$6 \times 10^6$	533.1	403.2	16	5	11	57097
3	$4 \times 10^7$	$6 \times 10^6$	533.1	403.2	18	6	13	64831
4	$2 \times 10^7$	$9 \times 10^6$	454.6	353.4	19	4	15	64499
5	$2 \times 10^7$	$12 \times 10^6$	403.2	353.4	27	4	12	76865

By adopting coefficients of variation of 0.15 for the compressive force, 0.25 for the load amplitude and 0.10 for the design stress, solution 1 was used to tune mean values for the static force, load amplitude and design stresses. The Gaussian distribution was adopted for all the random variables. Although the randomness of Young modulus also plays an important role in the structural reliability, this was not considered here for the sake of simplicity. In this example the probability of failure will be describe with the overall buckling stresses, the stiffener torsional buckling and the fatigue strength of the welded connections of stiffeners induced by the loadings. A maximum individual probability of failure  $p_f \leq 1.0E-4$  (beta larger than 3.72) was established. The following reliability based optimum solutions were obtained:

	$\mu_{N_{xstat}}$	$\mu_{\Delta N}$	$h_x$	$h_y$	$t$	$n_x$	$n_y$	<i>Cost</i>
1	$1.145 \times 10^7$	$2.95 \times 10^6$	403.2	257.2	13	6	19	54418
2	$1.172 \times 10^7$	$2.95 \times 10^6$	454.6	203.2	13	8	19	56336
3	$2.29 \times 10^7$	$2.95 \times 10^6$	607.6	403.2	15	6	14	61045
4	$1.145 \times 10^7$	$4.43 \times 10^6$	403.2	308.7	18	5	19	64389
5	$1.145 \times 10^7$	$5.9 \times 10^6$	403.2	403.2	24	4	16	75479

The reliability-based solutions are generally least costly than the deterministic and ensure the safety level adopted. If the all the modes are considered and the overall probability of failure  $p_f \leq 1.0E-4$  is imposed by using Ditlevsen improved second order bounds, the reliability based solutions for problems 4 and 5 are changed as in the first both the local buckling and fatigue have small  $\beta$  values and in the later the overall buckling and fatigue are critical.

	$\mu_{N_{xstat}}$	$\mu_{\Delta N}$	$h_x$	$h_y$	$t$	$n_x$	$n_y$	<i>Cost</i>
4	$1.145 \times 10^7$	$4.43 \times 10^6$	403.2	257.2	19	6	18	64977
5	$1.145 \times 10^7$	$5.9 \times 10^6$	403.2	353.4	25	4	15	76336

The solutions are 1% more costly, being thicker but reducing the number and sizes of the stiffeners in the y direction. The influence of the coefficient of variation of the static compressive force on solution 1 was also studied. If the coefficient of variation is increased by 10% to 0.165 the reliability-based solution becomes:

	$\mu_{Nxstat}$	$\mu_{\Delta N}$	$h_x$	$h_y$	$t$	$n_x$	$n_y$	$Cost$
1	$1.145 \times 10^7$	$2.95 \times 10^6$	403.2	308.7	14	6	16	54419

The fatigue constraint is now more important, replacing the local buckling constraint obtained in the previous reliability-based solution. There is almost no change in the cost, the solution now being thicker and with larger stiffeners in the y direction.

Fatigue is usually associated with a Weibull type II probability distribution and it is usually more demanding in terms of design than the normal distribution. If the probability distribution functions of the random variables are not Gaussian, the Rosenblatt transformation may be used. It consists of finding for each random value an “equivalent” Gaussian distribution function. An increased coefficient of variation for load variation of 0.275 was specified in problem 1. The following result was obtained:

	$\mu_{Nxstat}$	$\mu_{\Delta N}$	$h_x$	$h_y$	$t$	$n_x$	$n_y$	$Cost$
1	$1.145 \times 10^7$	$2.95 \times 10^6$	403.2	257.2	13	6	20	55072

This reliability-based solution is now 1% more costly. However this is obtained by increasing the number of stiffeners in the y direction.

#### References

- Farkas, J., Jármai, K. (2007): Economic orthogonally welded stiffening of a uniaxially compressed steel plate. *Welding in the World* **51** No.3-4, 80-84.
- Det Norske Veritas (1995): *Buckling strength analysis*. Classification Notes No.30.1. Høvik, Norway.
- Eurocode 3 (2002), Part 1-9. *Fatigue strength of steel structures*. Brussels.
- Farkas, J., Jármai, K. (2003): *Economic design of metal structures*. Rotterdam, Millpress 2003.
- Farkas, J., Jármai, K. (1997): *Analysis and optimum design of metal structures*. Rotterdam, Balkema. Section 9.1.4.4.
- Farkas, J., Jármai, K. (1996) Fatigue constraints in the optimum design of welded structures. *Int. Conf. Fatigue of Welded Components and Structures*. Senlis (France). Eds. Lieurade, H.P. and Rabbe, P. Les Editions de Physique, Les Ulis, France, 49-56.
- Hasofer, A.M. & Lind, N.C. (1974): Exact and invariant second moment code format, *J. Eng. Mech Div.* **100**(1), 111-121.
- Profil Arbed Sales program (2001), *Structural shapes*. Arcelor Long Commercial.
- Farkas, J. (2002) Thickness design of axially compressed unstiffened cylindrical shells with circumferential welds. *Welding in the World*, **46** No.11/12. 26-29.
- European Convention of Constructional Steelwork (ECCS) (1988), *Recommendations for Construction. Buckling of steel shells*. No.56. Brussels.
- Ditlevsen, O. (1979): Narrow reliability bounds for structural systems, *J. Struct. Mech.* **7** (4), 453-472.
- Simões, L.M.C. & Templeman, A.B. (1989): Entropy-based synthesis of pretensioned cable net structures, *Engineering Optimization*, **15**, 121-140
- Rosenblatt, M (1952) Remarks on a Multivariate Transformation, *Annals of Math. Stat.*, **23** 470-472.
- Simões, L.M.C., Farkas, J & Jarmai, K. (2006), Reliability-based optimum design of a welded stringer-stiffened steel cylindrical shell subject to axial compression and bending, *Struct. Multidisciplinary Optim.* **30**
- Farkas, J., Jármai, K. and Kozesh, Z. (2007) Cost minimization of an orthogonally stiffened welded steel plate subject to static and fatigue load, *Welding in the world*, **51**, special issue, pp. 357-366