



---

# Overview of NASA GRC's Efforts In SWBLI

10<sup>th</sup> Annual SWBLI Technical Interchange Meeting

Mary Jo Long-Davis

NASA Glenn Research Center

Chief, Inlets and Nozzles Branch

May 10-11, 2017



- **NASA Aeronautics Research Mission Directorate Programs and Projects**
- **NASA Glenn High Speed Inlet Technology**
  - **Stream-traced External Compression Inlet (STEX)**
  - **Quiet SuperSonic Technology (QueSST) model test in 8'x6' SWT**
- **NASA Glenn SWBLI CFD Activities**
- **NASA Glenn SWBLI Validation Experiment**

# NASA Aeronautics Research Six Strategic Thrusts



## Safe, Efficient Growth in Global Operations

- Enable full NextGen and develop technologies to substantially reduce aircraft safety risks



## Innovation in Commercial Supersonic Aircraft

- Achieve a low-boom standard



## Ultra-Efficient Commercial Vehicles

- Pioneer technologies for big leaps in efficiency and environmental performance



## Transition to Low-Carbon Propulsion

- Characterize drop-in alternative fuels and pioneer low-carbon propulsion technology



## Real-Time System-Wide Safety Assurance

- Develop an integrated prototype of a real-time safety monitoring and assurance system



## Assured Autonomy for Aviation Transformation

- Develop high impact aviation autonomy applications



# NASA Aeronautics Program Structure



## Aeronautics Research Mission Directorate



### Mission Programs

### Seedling Program

Advanced Air Vehicles (AAVP)

Airspace Operations And Safety (AOSP)

Integrated Aviation Systems (IASP)

Transformative Aeronautics Concepts (TACP)

Advanced Air Transport Technology Project (AATT)

Airspace Technology Demonstrations Project (ATD)

UAS Integration in the NAS Project

Transformative Tools and Technologies Project (T3)

Revolutionary Vertical Lift Technology Project (RVLT)

SMART NAS – Testbed for Safe Trajectory Operations Project

Flight Demonstration and Capabilities Project (FDC)

Convergent Aeronautics Solutions Project (CAS)

Commercial Supersonic Technology Project (CST)

Safe Autonomous System Operations Project (SASO)

Leading Edge Aeronautics Research for NASA Project (LEARN)

Hypersonic Technology Project (HT)

Advanced Composites Project (AC)

Aeronautics Evaluation and Test Capabilities Project (AETC)

Effective FY17



# What is the Advanced Air Vehicles Program (AAVP)?



The Fundamental Aeronautics Program, ground test capabilities, atmospheric environments related safety.

**Mission Program**

Conducts fundamental research to improve aircraft performance and minimize environmental impacts from subsonic air vehicles

Develops and validates tools, technologies and concepts to overcome key barriers, including noise, efficiency, and safety for vertical lift vehicles

Explores theoretical research for potential advanced capabilities and configurations for low boom supersonic aircraft.

Conducts research to reduce the timeline for certification of composite structures for aviation

Ensures the strategic availability, accessibility, and capability of a critical suite of aeronautics ground test facilities to meet Agency and national aeronautics testing needs.

**Advanced Air Vehicles Program**

Continues much of the research that was in the Fundamental Aeronautics Program, with a new focus on research that is directly related to the newly defined strategic thrusts. It now houses the Advanced Composites Project that was previously in the Integrated Systems Research Program. It also includes the ground test portion of the former Aeronautics Test Program.

## Projects

Advanced Air Transport Technology

Revolutionary Vertical Lift Technology

Commercial Supersonics Technology

Hypersonic Technology

Advanced Composites

Aeronautics Evaluation and Test Capabilities

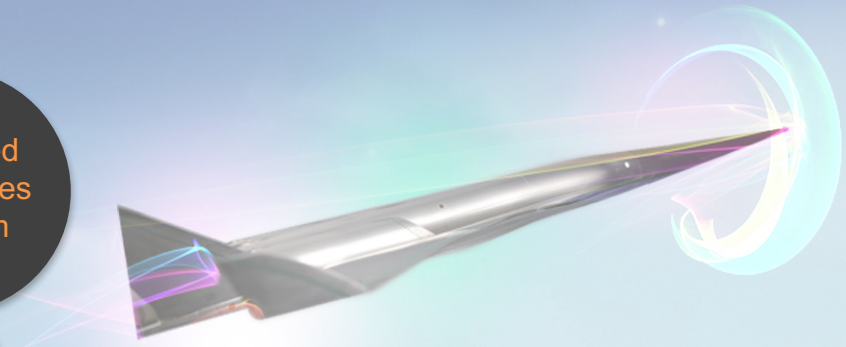

# What is the Transformative Aeronautics Concepts (TAC) Program?



While mission programs focus on solving challenges, this program focuses on cultivating opportunities.

Seedling Program

Transformative  
Aeronautics  
Concept  
Program

Cultivates multi-disciplinary, revolutionary concepts to enable aviation transformation and harnesses convergence in aeronautics and non-aeronautics technologies to create new opportunities in aviation

Knocks down technical barriers and infuses internally and externally originated concepts into all six strategic thrusts identified by ARMD, creating innovation for tomorrow in the aviation system.

Provides flexibility for innovators to explore technology feasibility and provide the knowledge base for radical transformation.

## Projects

Leading Edge Aeronautics Research for NASA

Transformational Tools & Technologies

Convergent Aeronautics Solutions

Solicits and encourages revolutionary concepts

Creates the environment for researchers to become immersed in trying out new ideas

Performs ground and small-scale flight tests

Drives rapid turnover into new concepts



- **NASA Aeronautics Research Mission Directorate Programs and Projects**
- **NASA Glenn High Speed Inlet Technology**
  - **Stream-traced External Compression Inlet (STEX)**
  - **Quiet SuperSonic Technology (QueSST) model test in 8'x6' SWT**
- **NASA Glenn SWBLI CFD Activities**
- **NASA Glenn SWBLI Validation Experiment**

# Proposed 8x6 SWT Test of Inward-Turning Low-Boom Inlet



## PROBLEM

Demonstrate the performance and operability of an inward-turning, high-performance, low-boom inlet with acceptable distortion levels to enable integration with a turbine engine.

## OBJECTIVES OF PROPOSED 8x6 SWT TEST

- (1) Validate the effects of bleed and other boundary layer control schemes (e.g., vortex generators) on overall inlet performance,
- (2) Provide better understanding of non-linear sub-critical phenomena,
- (3) Determine tolerance to angles of attack and yaw
- (4) Determine off-design Mach number performance

## APPROACH

Perform mechanical design, fabrication and GRC 8x6 Supersonic Wind Tunnel test of an inlet model. The model hardware will include using existing inlet adapter, cold-pipe, and mass flow plug. Existing adapter requires addition of rakes and hub to serve as Aerodynamic Interface Plane (AIP).

## STATUS

- Continuing to work STEX design at off-design conditions
- LTO conditions ( $0.1 < M < 0.3$ ), including aux inlets, angle of attack, angle of sideslip
- Paper on off-design performance to be presented at ISABE in Sept 2017.
- The AIP adapter (11.75" diffuser exit diam to 16" cold pipe/mass flow plug) is finished and will be shipped to the 8x6 for storage.
- Validation test article mech design complete; structural analysis underway. Preparing for fab estimate and build decision.

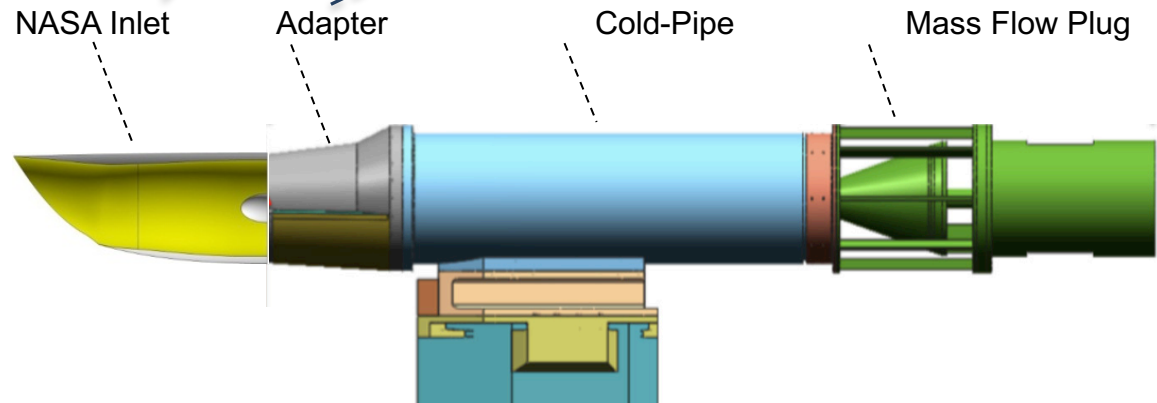
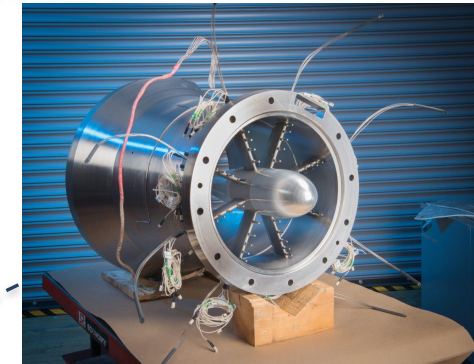
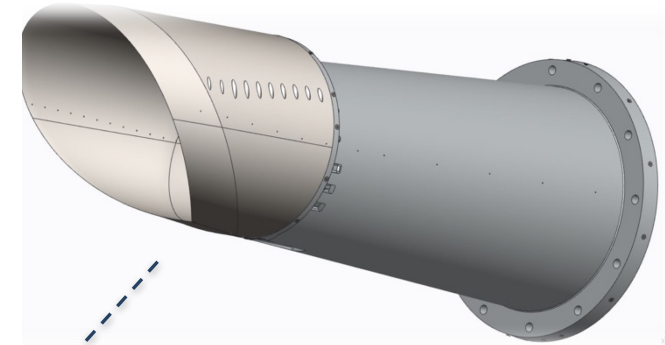

Sketch of proposed 8x6 Inlet Test Rig



- **NASA Aeronautics Research Mission Directorate Programs and Projects**
- **NASA Glenn High Speed Inlet Technology**
  - **Stream-traced External Compression Inlet (STEX)**
  - **Quiet SuperSonic Technology (QueSST) model test in 8'x6' SWT**
- **NASA Glenn SWBLI CFD Activities**
- **NASA Glenn SWBLI Validation Experiment**



# Quiet SuperSonic Transport (QueSST) Test

## 8x6-Foot Supersonic Wind Tunnel



**OBJECTIVE:** To verify the aerodynamic performance predictions of the fuselage shape, control surfaces and engine inlet using a 9%-scale wind tunnel model of a low-boom vehicle design



**POCs:** Ray Castner, John Slater, Vance Dippold, David Friedlander, Chuck Trefny, Chris Heath, Jon Seidel (GRC)

# Test Objectives

---



- The Quiet Supersonic Technology (QueSST) test series will occur in two phases:
  - Aerodynamic
    - Will test a live balance installed to collect differential stability data on various control surface configurations and inlet flow-through nacelle screens.
  - Propulsion
    - Will test with a varied inlet and nozzle in order to collect inlet performance information.
- Collect Background Oriented Schlieren (BOS) around inlet areas if possible and schedule permits.

# Model Hardware

## Aero Configuration



- Sting mounted with 6-component live balance
- Spike extends 5.1-in from nose
- 8 change-able control surfaces
- Total model length, nose (no spike) to tail:
  - 106.5-in
- Total wing span:
  - 33.6-in
- Total length nose (no spike) to strut LE:
  - 174.7-in
- Test Section Station (nose, no spike):
  - TS 145.3
- Total configurations:
  - 53 minor

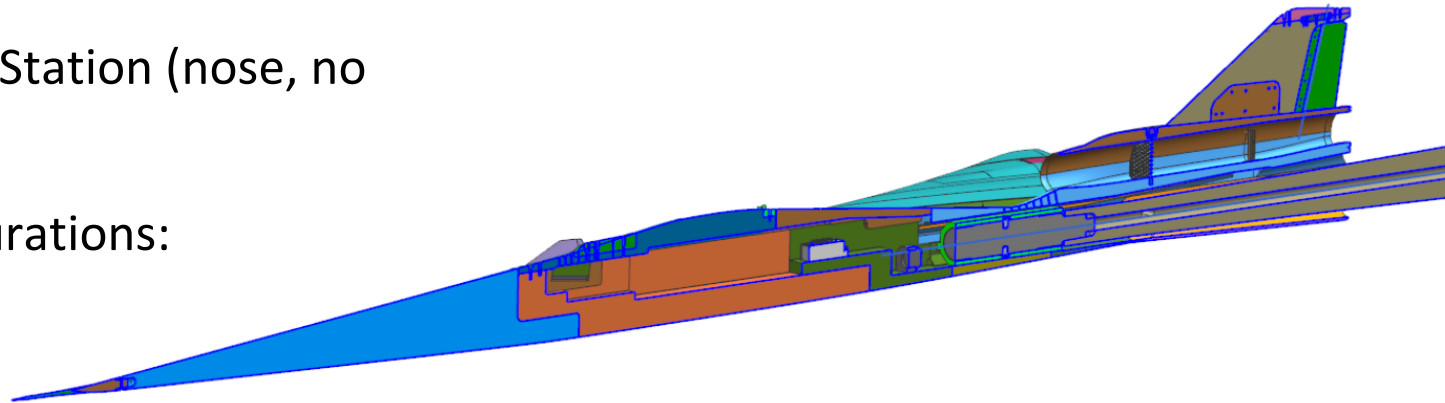



# Model Hardware

## Propulsion Configuration



- Blade-to-sting mounted with NO balance
- Aft geometry changed
  - No tails/stabilizers
- Total model length, nose (no spike) to MFP mixing can:
  - 124.7-in
- Total wing span:
  - 33.6-in
- Total length nose (no spike) to strut LE:
  - 174.7-in
- Test Section Station (nose, no spike):
  - TS 145.3
- Total configurations:
  - 6 minor

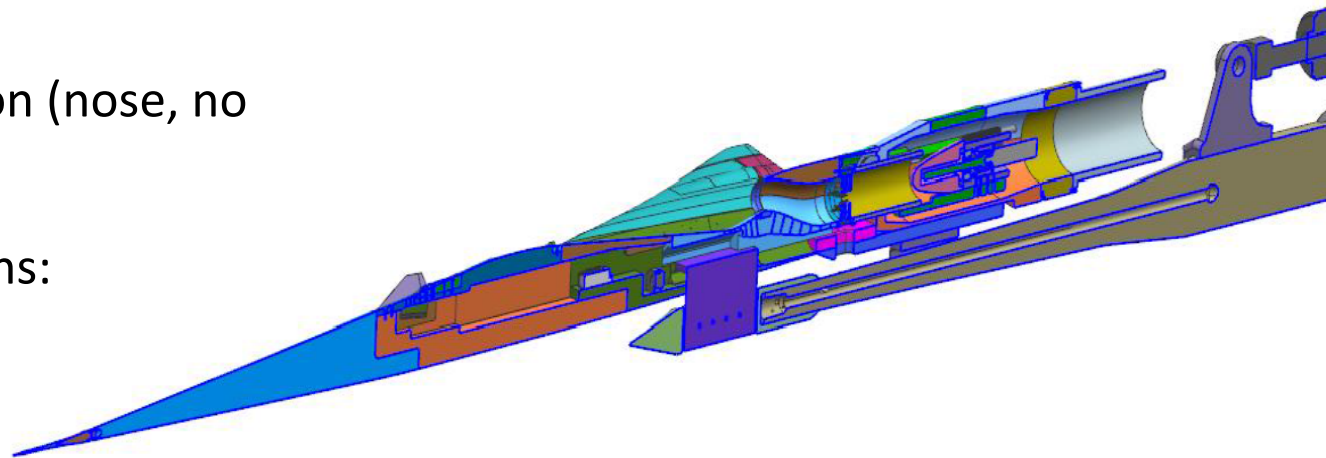

# Model Hardware Propulsion Configuration

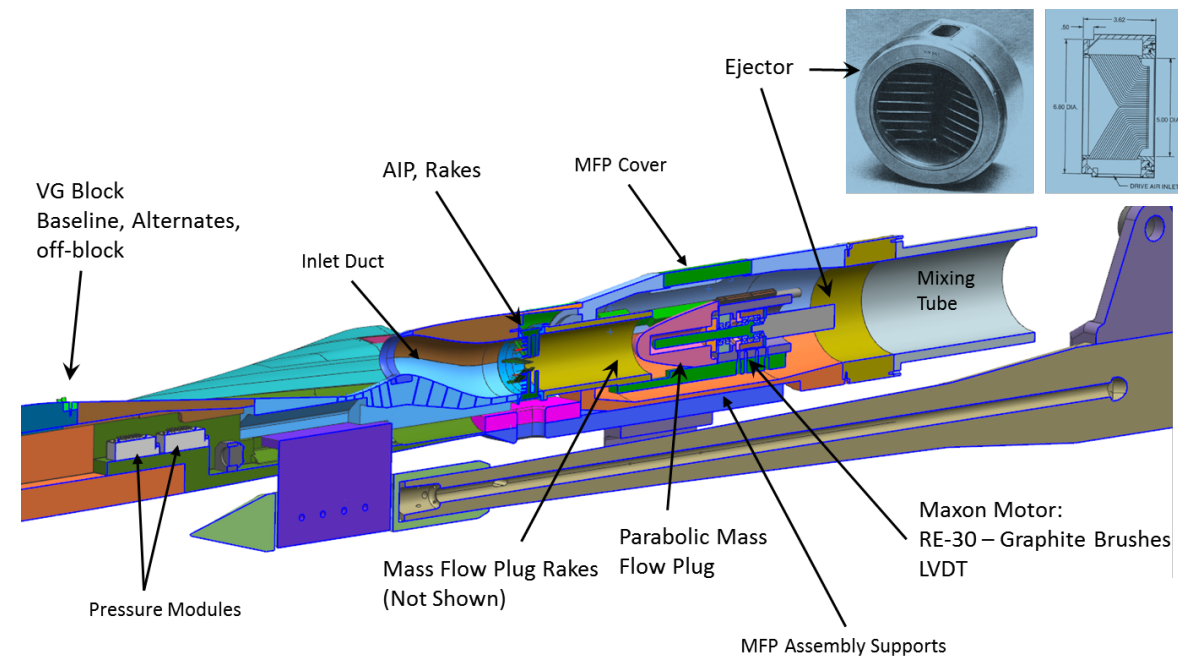

- Linear actuation of plug via electric motor
- AIP diameter: 3-in
- MFP diameter: 3-in
- Total MFP travel: 2.8-in
- Ejector only needed when MFP pressure ratio is less than 2.0
- Ejector requirements:
  - 100-psig compressed air
  - 0.9-lbm/sec
- Ejector supply from 450-psig air system



# Propulsion Airframe Integration CFD



Potential need for additional validation data and CFD tool refinements

- NASA analysis of C607.1 design was performed:
  - Large differences (>5%) in NASA FUN3D vs. LM CFD++ inlet recovery and distortion.
  - Differences attributed to predicted flow-field on top of vehicle.
- At GRC, the QueSST project marks the first time full vehicle aerodynamic analysis was performed using FUN3D on a mature vehicle design.
- The QueSST aircraft is unique in that it contains an aft-fuselage, top-mounted inlet installation, with complex shock-wave boundary-layer interactions that are sensitive to geometry and difficult to predict.
- Depending on the success of this first test, more investment/validation data sets likely needed to bring PAI best practices up to the same maturity level as sonic boom analysis.

Cruise Pt,  
Mach 1.42, AOA 1.7

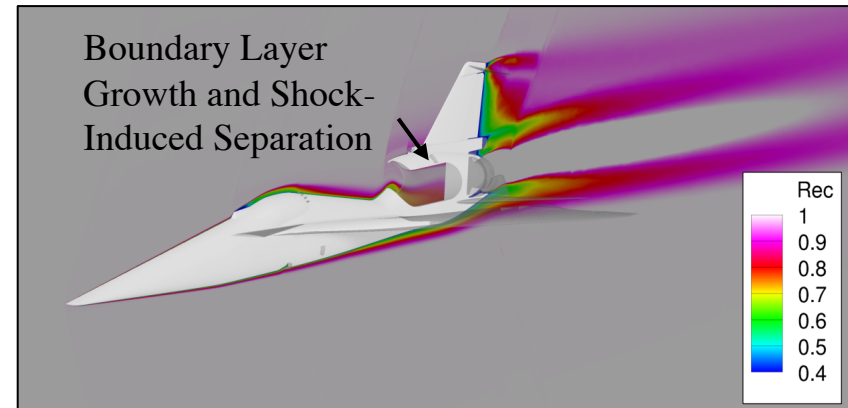
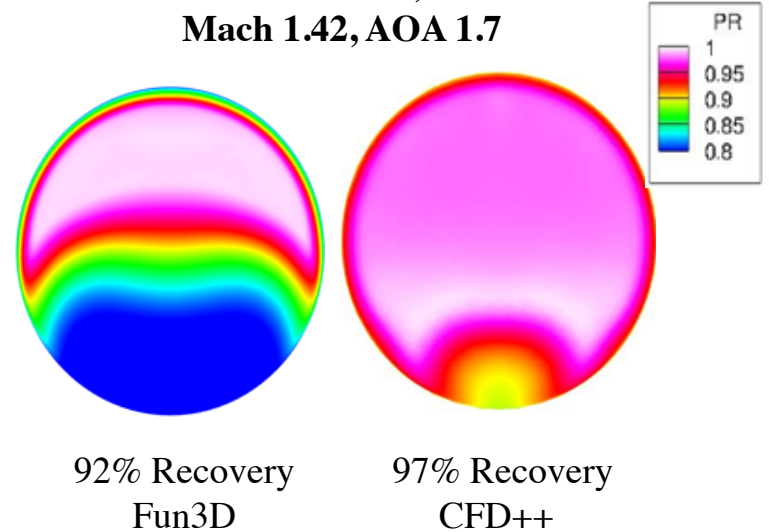



# Study of VGs on the QueSST Inlet (C606)



## Objectives:

- Vortex generators in current design are used to sweep the boundary layer away from inlet.
- NASA explored smaller vortex generators (VGs) aft of the cockpit to reduce drag and shocks generated by the VGs.
- Examine effect of design factors (height, length, angle).

## Approach:

- Use Wind-US CFD code with vortex generator model.
- Simplified aircraft for structured grid to focus on VGs.
- Consider effect on boundary layer at inlet entrance.

## Results/Significance:

- Study showed smaller VGs can effectively be used to sweep the boundary layer away from the inlet.
- Alternate VG designs were shared with Lockheed for consideration in future configuration updates.

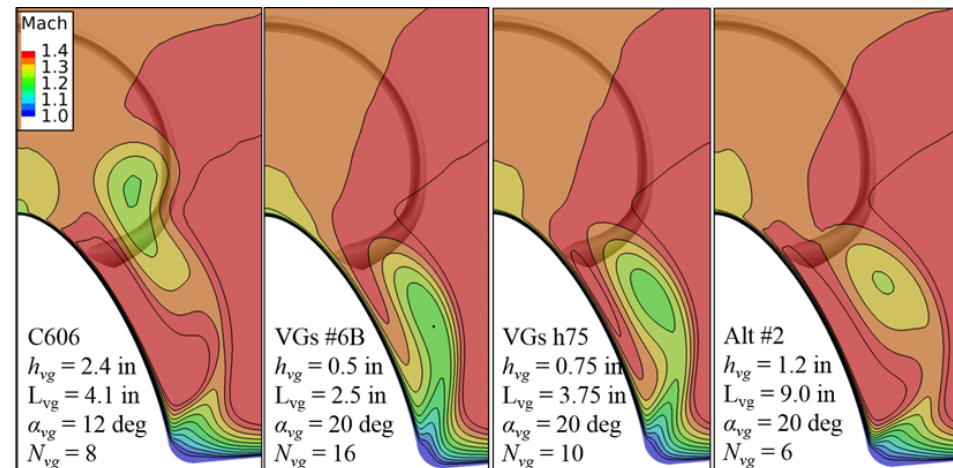
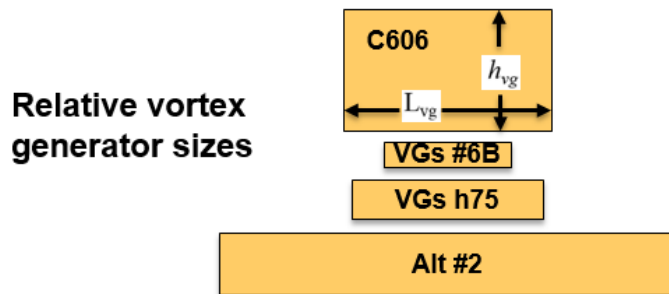
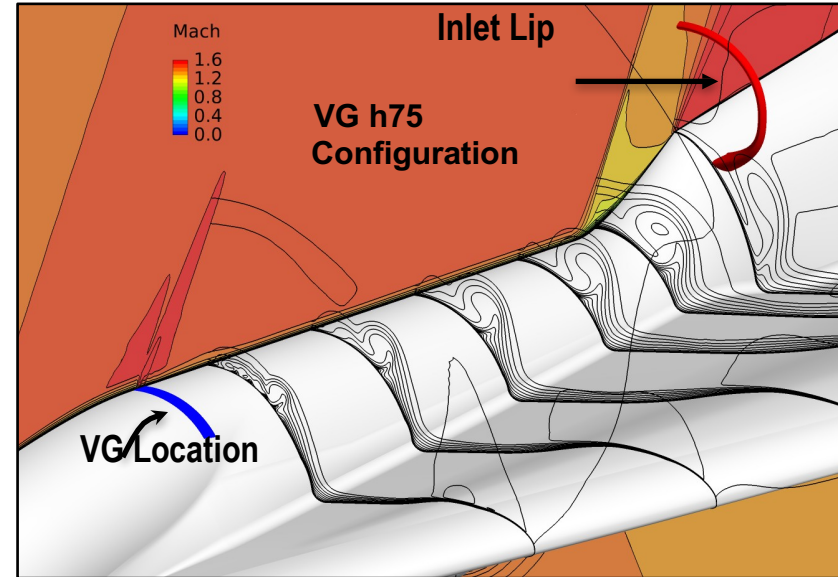



- **NASA Aeronautics Research Mission Directorate Programs and Projects**
- **NASA Glenn High Speed Inlet Technology**
  - **Stream-traced External Compression Inlet (STEX)**
  - **Quiet SuperSonic Technology (QueSST) model test in 8'x6' SWT**
- **NASA Glenn SWBLI CFD Activities**
- **NASA Glenn SWBLI Validation Experiment**

# Transformational Tools & Technologies Project

## Level 2 Milestone Completion



**Due Date:**  
03/31/2017

**Milestone:**  
Evaluate advanced RANS and scale resolving simulations capability for prediction of shock-boundary layer interactions.

**Exit Criteria:**  
Quantify improvement in shock induced separation length and associated improvements in prediction of Reynolds stresses.

POCs: Nick Georgiadis, Julie Dudek, Manan Vyas and Jim DeBonis (GRC)

UFAST M2.25 SWBLI

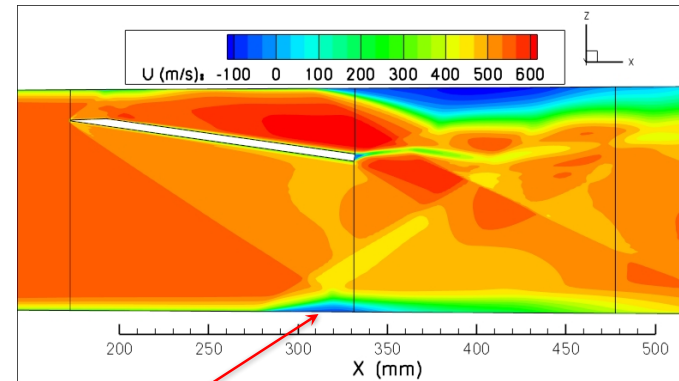

SWTBLI Focus region

Transonic Diffuser

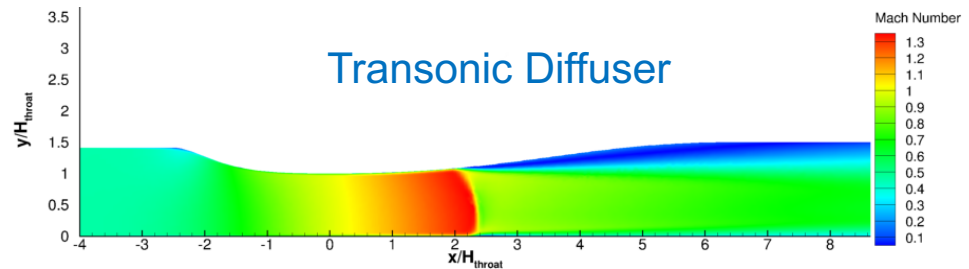

30deg Axi Compression Corner

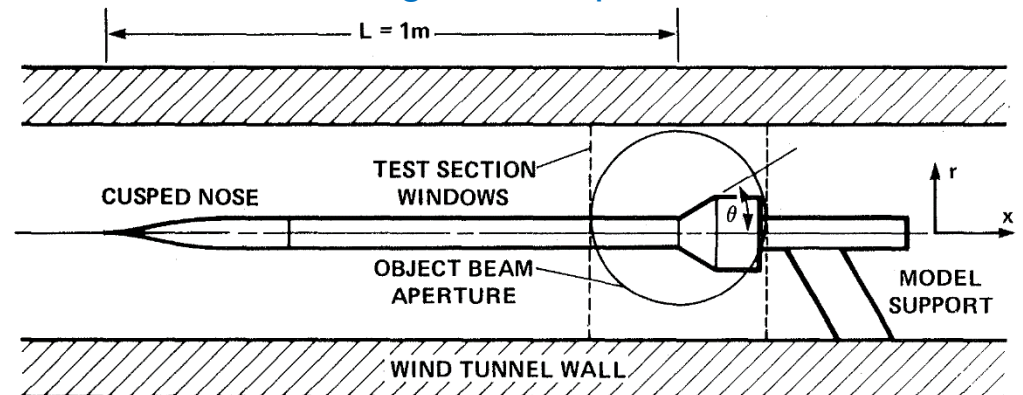

# Summary of GRC SWBLI CFD Activities



- The effect of the shear stress limiter in the Shear Stress Transport (SST) model was examined for shock separated flows
  - Experimental data was used to characterize shear stress behavior
  - The SST model was adjusted to better replicate the experimental findings
  - Improved shock boundary layer predictions were obtained with the modified SST model
- Reynolds stress models (SSG/LRR & Wilcox) were evaluated for transonic diffuser and supersonic compression corner flows
  - Provide enhanced physics and potential for more accurate predictions in some flows (physical representation of turbulence intensities)
  - RSMs were very sensitive to the numerical scheme
  - RSMs did not show significant benefit boundary layer separation prediction
  - Need for additional research and include Algebraic Reynolds Stress models
- LES was used to simulate the UFAST shock boundary layer interaction
  - Digital filtering turbulent inflow generation created accurate boundary layer profiles upstream of the shock
  - Separation is greatly under-predicted
  - Several areas are being investigated including numerical schemes, grid etc.





# Investigation of Shear Stress Limiter

- The Menter Shear Stress Transport (SST) model is possibly the most widely RANS used turbulence model for aerospace flows. It is a  $k$ - $\omega$  model with “shear stress transport” part of the model coming from the limiter:

$$\mu_t = \min\left(\frac{\rho k}{\omega}; \frac{a_1 \rho k}{\Omega F_2}\right)$$

- The Menter BSL model is very similar to SST, but with no limiter.
- Shear stress limiter sets  $a_1 = 0.31 = -u'v'/k$ , using observations of Bradshaw, Townsend, & others -- for zero pressure gradient and mild adverse gradient flows.
- Experimental data (UFAST, Smits et al, others) shows  $-u'v'/k$  exceeds 0.31 in SWTBLI flows. This quantity is known as the “structure parameter.”
- Others (Wilcox, Tan and Jin, Edwards) also have investigated values for  $a_1$  greater than 0.31.
- **This work:**
  1. **A range of  $a_1$  from 0.31 to 0.40 was investigated, for several cases including SWTBLIs. (Larger values for  $a_1$  are very similar to BSL)**
  2. **Examined details of experimental turbulent measurements alongside computations to determine appropriate value(s) for  $a_1$  in SWTBLI flows.**

# UFAST SWBLI Test Case

*2010 AIAA SWTBLI Workshop*



- Mach 2.25 flow approaching SWTBLI region.
- Several RANS and LES (including hybrid RANS-LES) solutions submitted; most widely used RANS turbulence models were SST and SA.

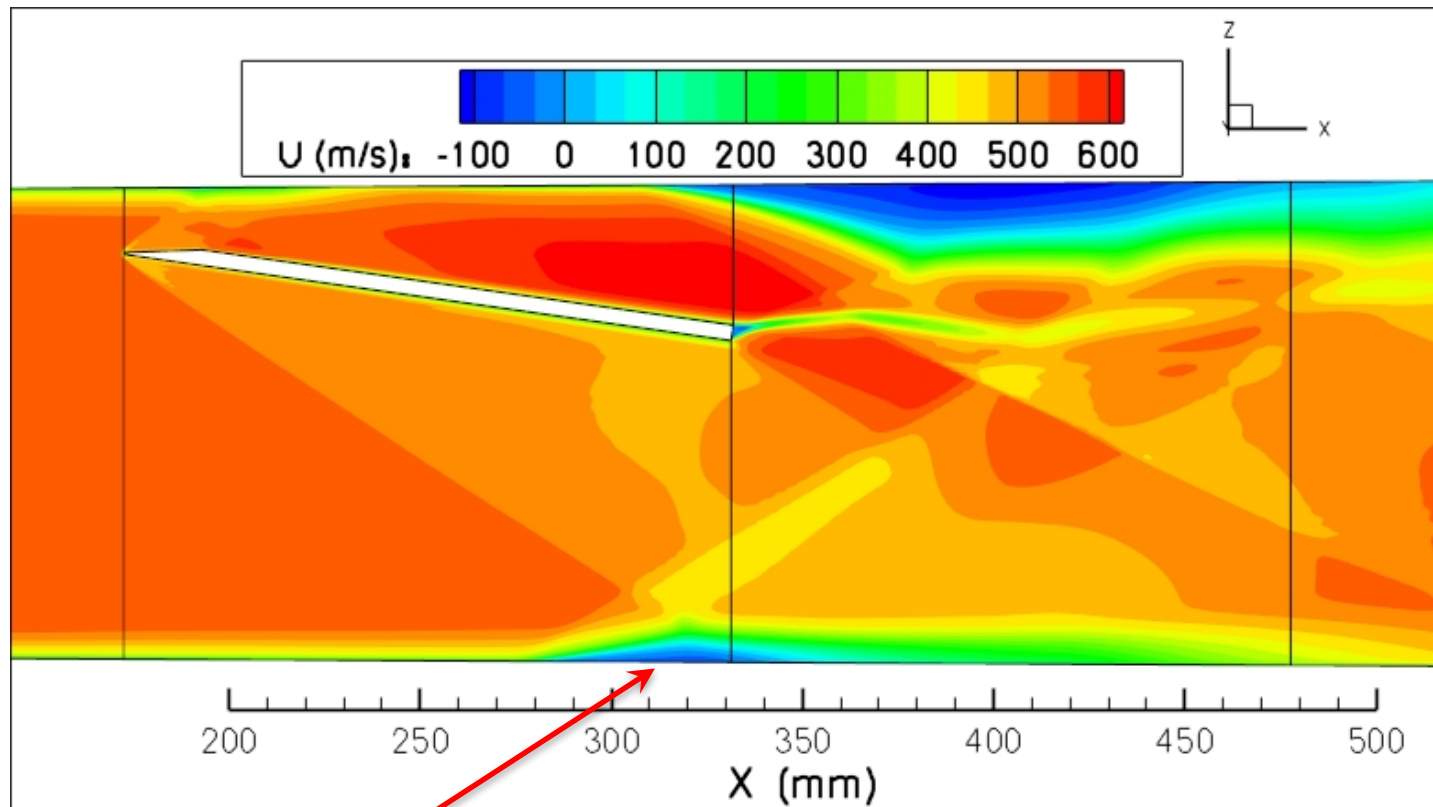

*SWTBLI Focus region*

# UFAST Results when varying “ $a_1$ ”

*Experiment*

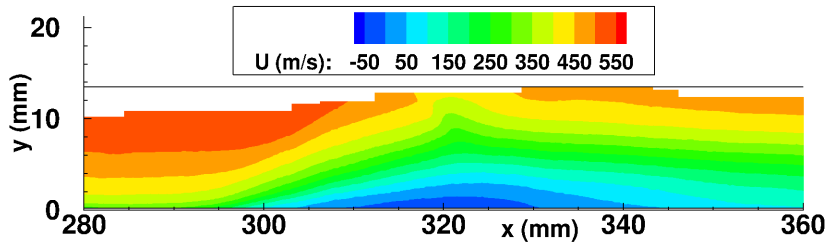

*Menter SST  $k-\omega$*

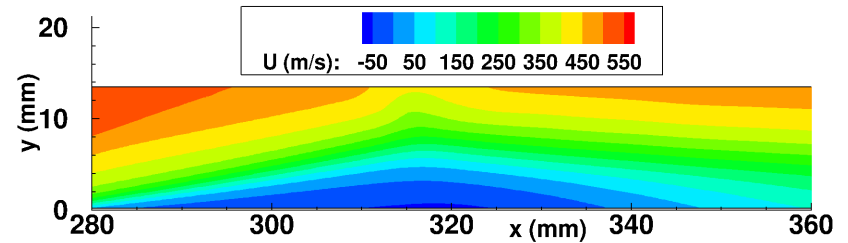

*Menter BSL  $k-\omega$*

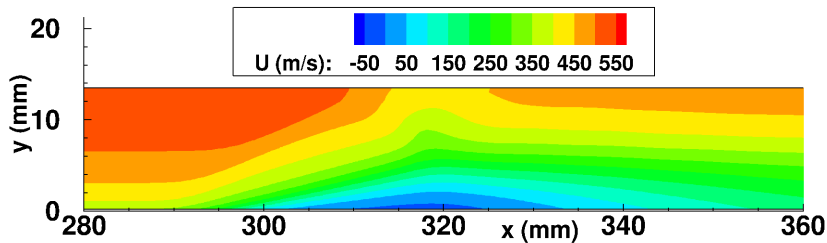

*Menter SST  $k-\omega$ ,  $a_1 = 0.355$*

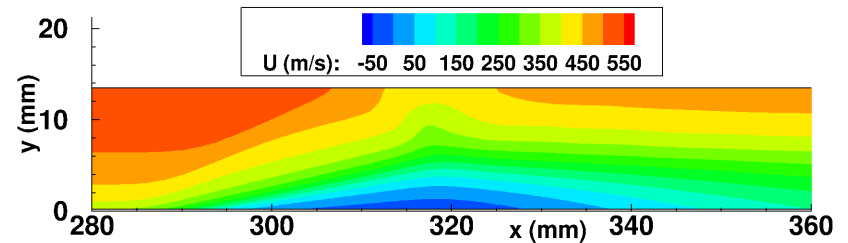

- BSL and SST models provide solutions on either side of experimental data for SWTBLIs.
- For all flows, but especially SWTBLIs, increasing  $a_1$  results in less limiting of turbulent shear stress.....smaller separations.
- **$a_1 = 0.355$  is recommended value for SWTBLI problems.**
- **The capability to vary  $a_1$  was added to Wind-US version 4. The most recent Wilcox  $k-w$  also uses a larger effective value for  $a_1=0.343$ .**



- **NASA Aeronautics Research Mission Directorate Programs and Projects**
- **NASA Glenn High Speed Inlet Technology**
  - **Stream-traced External Compression Inlet (STEX)**
  - **Quiet SuperSonic Technology (QueSST) model test in 8'x6' SWT**
- **NASA Glenn SWBLI CFD Activities**
- **NASA Glenn SWBLI Validation Experiment**

# Turbulence CFD Validation Experiments (TCFDVE)

## PROBLEM

Very few Shock Wave/Boundary-Layer Interaction (SWBLI) experiments reported in the open literature meet the rigorous criteria required to be considered as a CFD validation dataset. This is particularly true for experiments with detailed turbulence measurements.

## OBJECTIVES

Obtain mean and turbulence quantities through a  $M=2.5$  SWBLI of sufficient quantity and quality to be considered as a CFD validation dataset. Initial efforts will focus on a Mach 2.5 2-D (in the mean) interaction with follow-on efforts investigating 3-D interactions. Both attached and separated interactions will be considered.

## APPROACH

A new  $M=2.5$  17cm axisymmetric facility has been constructed to investigate SWBLIs. The facility is located in Test Cell W6B at NASA GRC. The SWBLI is generated by a cone-cylinder located on the centerline of the facility. The strength of the interaction is varied by changing the cone angle. The measurement region of interest is where the conical shock interacts with the naturally occurring facility boundary-layer that is highlighted by the box shown in Figure 1. The new facility will be instrumented with conventional pressure instrumentation as well as hot-wire anemometry for measurement of turbulence quantities. Non-intrusive optical techniques such as PIV will be incorporated in the future. Test are also planned with dynamic surface shear film and fast response Pressure Sensitive Paint (PSP) in collaboration with Innovative Scientific Solutions, Incorporated (ISSI).

## RESULTS

Normal hot-wire measurements have been completed.

## SIGNIFICANCE

The data to be generated has been previously unavailable. Further, development of an in-house capability to investigate SWBLIs will allow CFD code developers and turbulence modelers to have direct input into the experiment. It will also allow the ability to revisit measurements if deemed necessary.

**POC: David O. Davis (GRC)**

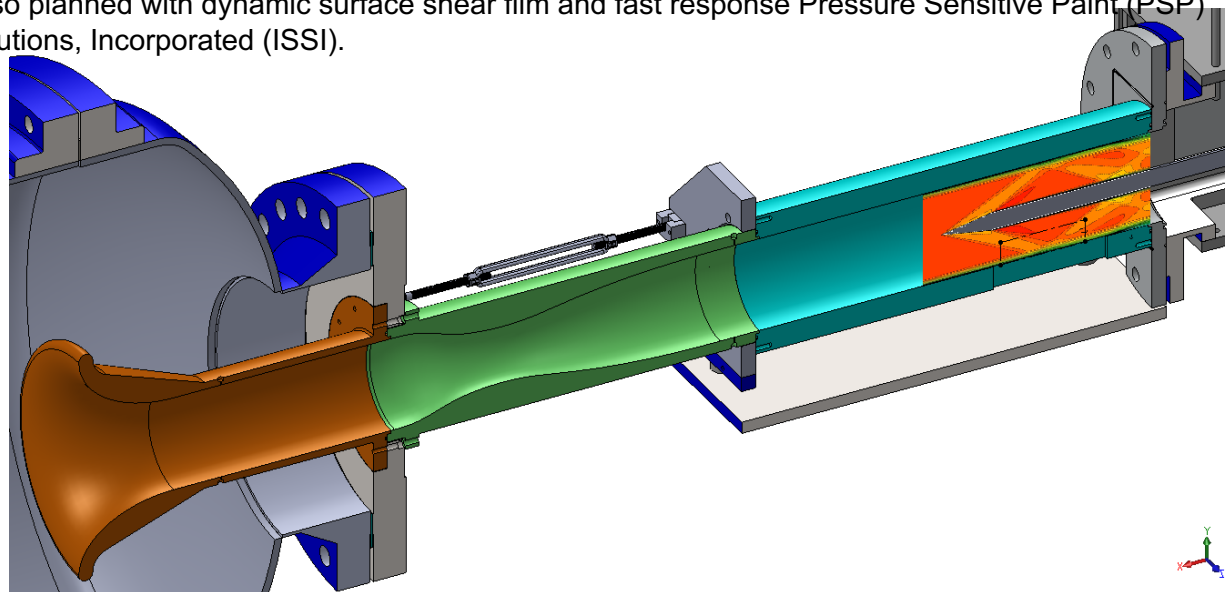

**17cm Axisymmetric Supersonic Wind Tunnel**

