

# Exploration Mission Particulate Matter Filtration Technology Performance Testing in a Simulated Spacecraft Cabin Ventilation System

Juan H. Agui<sup>1</sup>

*NASA, John H. Glenn Research Center, Cleveland, Ohio, 44135, USA*

R Vijayakumar<sup>2</sup>

*Aerfil, Liverpool, New York, 13088, USA*

Jay L. Perry<sup>3</sup> and Kenneth R. Frederick<sup>4</sup>

*NASA, George C. Marshall Space Flight Center, Huntsville, Alabama, 35812, USA*

Robert M. McCormick<sup>5</sup>

*Qualis Corp./Jacobs ESSSA Group, Huntsville, Alabama 35806, USA*

**Human deep space exploration missions will require advances in long-life, low maintenance airborne particulate matter filtration technology. As one of the National Aeronautics and Space Administration's (NASA) developments in this area, a prototype of a new regenerable, multi-stage particulate matter filtration technology was tested in an International Space Station (ISS) module simulation facility. As previously reported, the key features of the filter system include inertial and media filtration with regeneration and in-place media replacement techniques. The testing facility can simulate aspects of the cabin environment aboard the ISS and contains flight-like cabin ventilation system components. The filtration technology test article was installed at the inlet of the central ventilation system duct and instrumented to provide performance data under nominal flow conditions. In-place regeneration operations were also evaluated. The real-time data included pressure drop across the filter stages, process air flow rate, ambient pressure, humidity and temperature. In addition, two video cameras positioned at the filtration technology test article's inlet and outlet were used to capture the mechanical performance of the filter media scrolling operation under varying air flow rates. Recent test results are presented and future design recommendations are discussed.**

## Nomenclature

<i>DAC</i>	=	data acquisition and control
<i>GRC</i>	=	Glenn Research Center
<i>HEPA</i>	=	high efficiency particulate air
<i>HVAC</i>	=	heating, ventilation, and air conditioning
<i>ISS</i>	=	International Space Station
<i>MSFC</i>	=	Marshall Space Flight Center
<i>NASA</i>	=	Bacterial Filter Element
<i>PACRATS</i>	=	Payloads and Components Real-time Automated Test System
<i>REMS</i>	=	Regenerative Environmental Control and Life Support System Module Simulator
<i>SFS</i>	=	Scroll Filter System

---

<sup>1</sup> Aerospace Engineer, Fluid Physics and Transport Branch, NASA Glenn Research Center/77-5.

<sup>2</sup> Consultant in Chief, 300 Cypress St., #41.

<sup>3</sup> Lead Aerospace Engineer, Space Systems Dept., George C. Marshall Space Flight Center/ES62.

<sup>4</sup> Test Engineer, ECLS Systems Development Branch, Space Systems Dept., Mail Stop ES62.

<sup>5</sup> ECLSS Engineer, Qualis Corp./Jacobs ESSSA Group, Space Systems Dept., Mail Stop ES62.

<i>SMF</i>	=	Scroll Media Filter
<i>SRF</i>	=	Screen Roll Filter
<i>atm</i>	=	atmosphere
<i>C</i>	=	Celsius
<i>cfm</i>	=	cubic feet per minute
<i>cm</i>	=	centimeter
<i>F</i>	=	Fahrenheit
<i>ft</i>	=	foot
<i>m</i>	=	meter
<i>min</i>	=	minute
<i>mL</i>	=	milliliter
<i>mm</i>	=	millimeter
<i>Pa</i>	=	pascal
<i>s</i>	=	second
$\mu g$	=	microgram

## I. Introduction

**H**UMAN deep space exploration missions will require advances in long-life, low maintenance airborne particulate matter filtration technology. The cost of launch mass and the logistics of resupply impose very tight and challenging constraints on the compositional and operational design of space-bound hardware. In this case, systems that save on mass, volume, and power, and that last the length of the mission with minimal maintenance are attractive alternatives over current state-of-the-art systems.

The Scroll Filter System (SFS) is a developmental filter system that originated at the National Aeronautics and Space Administration's (NASA) John H. Glenn Research Center (GRC) under the Exploration Technology Development program's Exploration Life Support project, and is currently managed under the Advanced Exploration Systems program's Life Support Systems project. The filter system offers long operational life through various innovations. The key features of the filter system include inertial and media filtration with regeneration and in-place media replacement techniques. References 1 and 2 discuss the design and operational aspects of the various sized prototypes and stages of the filter system. The current prototype is designed as a centralized unit consisting of large hardware components. The benefits of centralized components are mass savings and reduced servicing. As indicated in Ref. 3, savings in frame and housing materials are realized with a centralized unit when compared with set of a smaller units handling the same total flow rate. As a result, a substantial reduction in the number of replacement units is envisioned with a corresponding reduction in servicing. Ideally centralized units, if sized properly in the absence of size-constraints, may be designed to last a full mission with little to no crew-tended servicing. Scaling up the hardware on the other hand required a few significant design changes of the SFS to perform nominally under large flow rates

The performance of the centralized SFS was tested at NASA's GRC on a bench top ventilation flow duct, and in one of the NASA's International Space Station (ISS) habitat module simulators at the George C. Marshall Space Flight Center (MSFC). The objective of these simulated tests was to assess the performance of the filter system under flight configurations, interfaces, and ventilation conditions. This paper will discuss the results for the initial test series and will address hardware issues that became apparent during testing. In addition, subsequent hardware modification and retesting will also be presented.

## II. Test Facility and Methods

The SFS was tested in facilities at NASA GRC and NASA MSFC. The testing conducted at MSFC involved integrating the SFS components in a cabin ventilation duct while the testing conducted at GRC employed a bench testing approach. The test configurations are depicted in Fig. 1.

### A. The Regenerative Environmental Control and Life Support System Module Simulator Facility

The SFS prototype was integrated into a cabin ducting system in the Regenerative Environmental Control and Life Support System Module Simulator (REMS)—an approximately 201 m<sup>3</sup> chamber equipped with a ventilation system that includes ISS flight-like blower and condensing heat exchanger components. The REMS facility, used previously for ISS water processing system development and validation testing, provides test condition control, data acquisition, and test monitoring capabilities.

### 1. Test Article Integration in the REMS Facility

Each filter test article was integrated with a duct transition upstream of the REMS cabin ventilation blower as shown by Fig. 1a. Figure 2 depicts a simplified test configuration process and instrumentation diagram that shows the primary instrumentation locations relative to the filter test article. The filter test article was mounted at the inlet upstream of the REMS condensing heat exchanger and blower as shown in Figs. 1 and 2. A hood flow meter was installed at the test article flow inlet to measure the process air flow.

Physical integration was established through a mounting method to allow ease of installation and change out of filter elements between testing runs. Mating holes were provided in all three filter element mounting flanges as well as the interfacing flange of the existing module interface duct for attachment. Foam gasket material was used between mating surfaces to minimize air leakage.

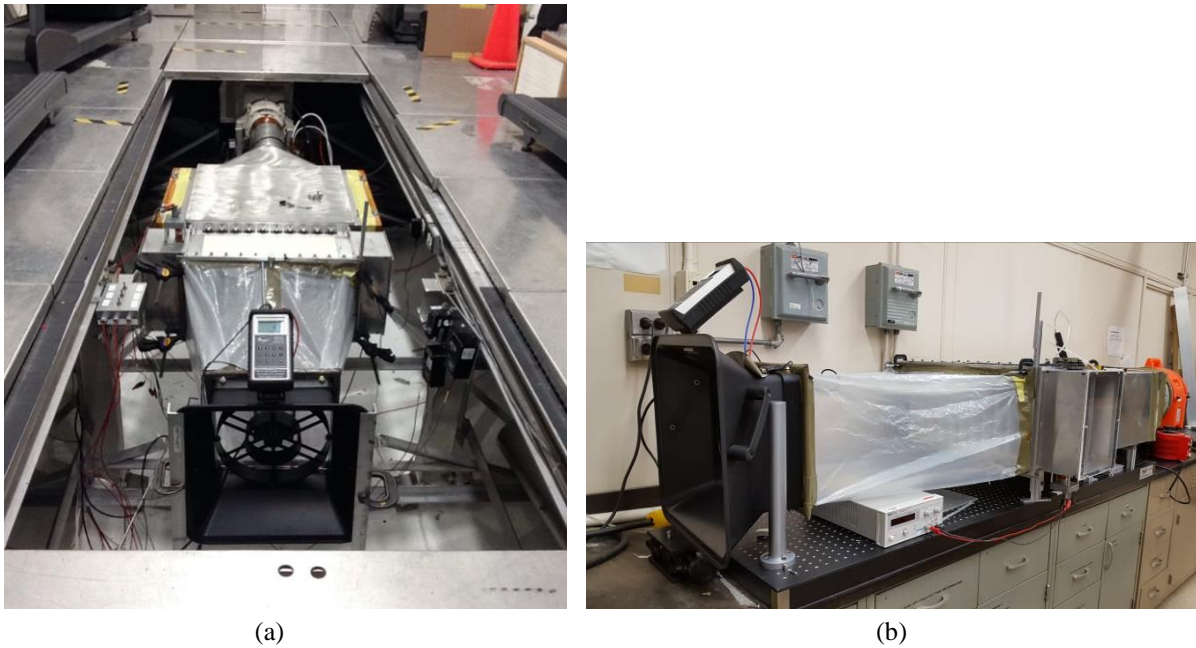

**Figure 1. Testing configurations.** a) Filter test articles in the REMS ventilation duct system at NASA MSFC and b) bench setup at NASA GRC.

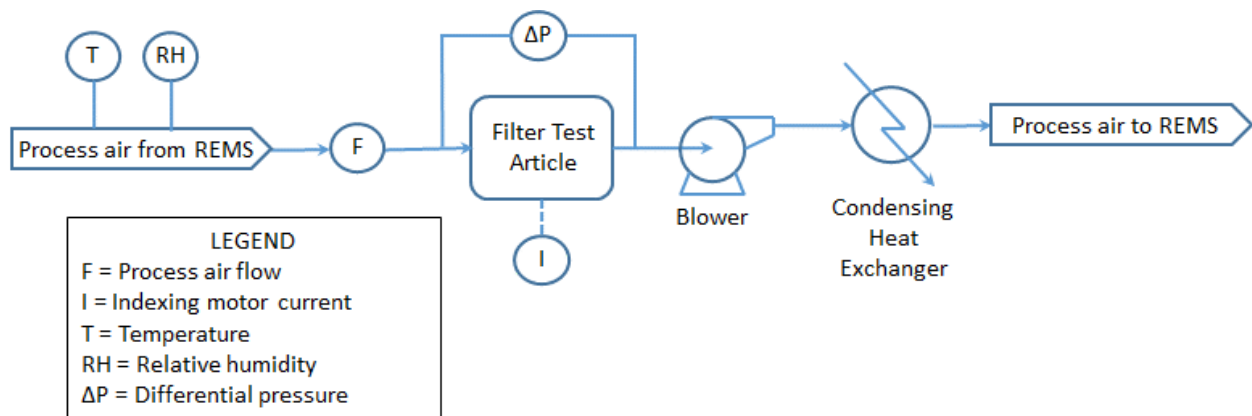

**Figure 2. Filter testing simplified process and instrumentation diagram for the REMS configuration.**

## 2. Data Acquisition and Control for the REMS Testing Configuration

The scroll filter test data acquisition and control (DAC) system included a National Instruments Compact FieldPoint network module with an Ethernet/serial interface (NI cFP-1808) and an analog voltage and current input module (NI cFP-AI-110), a Hewlett Packard (HP) 3852A DAC system and a DAC computer. The software on the DAC computer is a LabVIEW (National Instruments) program that acquires data from sensors monitoring test conditions, filter test article differential pressure, and test article scroll motor power. All test data, with the exception of video, was recorded by the Payloads and Components Real-time Automated Test System (PACRATS).

Test conditions in the REMS were monitored using a Sable Systems RH-300 (Model 669624) dewpoint meter that provided relative humidity (%), temperature ( $^{\circ}\text{F}$ ), water vapor pressure (Torr), and water vapor density measurements ( $\mu\text{g}/\text{mL}$ ). The pressure drop and flow across the scroll filter test articles was measured via a Validyne differential pressure sensor (Intake to exhaust) and a Dwyer TT550DV digital micromanometer. The scroll filter motor power was monitored using a CR Magnetics (CR5210-0.5) current transducer that measured current flowing through the active motor in the scroll pump assembly. The test control program transmits an on/off command and an analog voltage command to the REMS cabin blower controller through the facility HP 3852A DAC system. The air flow indicated by the Dwyer TT550DV digital micromanometer was compared with a TSI, Inc. VelociCalc (Model 642557) at several locations within the  $30.5\text{ cm} \times 30.5\text{ cm}$  intake and at several flow rates prior to the test.

A camera system was installed for the test. Two HIKVISION IR CUBE network cameras were installed at the in-take (Network Camera 1) of the scroll filter assembly and the exhaust (Network Camera 2). Network camera 2 was installed inside the duct transition immediately downstream of the filter test article and was recorded in the infrared mode. The web interfaces of each camera ran on Microsoft Internet Explorer 11 with administrative privileges in the Microsoft Windows 10 operating system. A HIKVISION conversion utility was used to convert the video data from a PS2 format to an MP4 format. The video was recorded during each test run.

### B. Bench Testing Configuration

Additionally, smaller scale tests were conducted at the NASA GRC in order to obtain an initial performance assessment and to test hardware modifications prior to testing at the NASA MSFC's REMS facility. A picture of the setup at NASA GRC is shown in Fig. 1b. The air flow hood with a digital micromanometer was used at the inlet to the filter as in the REMS facility. A transition aluminum duct channel was used to connect the filter to a commercial portable axial blower that was controlled through a variable transformer to achieve different flow rates. A low pressure range, 623 Pa (2.5 inches  $\text{H}_2\text{O}$ ), differential pressure transducer was used to measure the pressure drop across the filter. Air room temperature and barometric pressure was obtained in the laboratory through a flowmeter (TSI, Inc.) in an adjacent setup. A high definition Go-Pro HERO3 wireless camera was also mounted internally in the duct channel to monitor indexing operation.

## III. Scroll Filter System Component Description

The SFS has been under development within NASA's portfolio of life support system technology developments. The filter system is quite scalable within the design space of cabin ventilation systems and adaptable both in performance and geometry. The SFS consists of four stages of configurable and tunable filtration performance providing a specific filtration function at each stage. The current prototype was sized as a centralized unit with an open cross-section of  $30.5\text{ cm} \times 61\text{ cm}$  (1ft  $\times$  2 ft). The following provides general descriptions of each stage.

### A. Screen Roll Filter

The Screen Roll Filter (SRF) shown by Fig. 3a is a pre-filter which uses screen mesh material of specific mesh size opening. Its function is to capture large lint matter and other large airborne debris. The SRF uses a supply roll of the screen material to provide multiple changes of the screen through a motorized (autonomous or manually activated) mechanism. The loaded screen media is then rolled up on one side of the filter to store the captured PM matter.

### B. Impactor Filter

The Impactor Filter shown by Fig. 3b is a pre-filter which uses inertial impaction through area reducing devices (e.g. orifice or slits) for separating and collecting particles several microns and larger on collection bands placed just downstream of the reducing area devices. The collection bands are regenerated by using a band conveying mechanism and a scraper. The collection performance of the impactor can improve by increasing the number of area reducing devices, while adjusting the open area to maintain high jet velocities through the openings, for a given flow rate.

### C. Scroll Media Filter

A Scroll Media Filter (SMF) shown by Figs. 3c and 3d is a pre-filter or intermediate stage filter that provides multiple changes of the filter media inside the ventilation flow volume through a motorized scrolling or indexing mechanism. The filter media can be arranged in a pleated pattern using support spindles to increase the filtration surface area. Like the SRF, the loaded media is rolled up on one side of the filter to both contain and compactly store the loaded PM. A series of supports are used in the flow volume to arrange the media in a pleated pattern.

### D. High Efficiency Filter

A finishing filter at the last stage of filtration is used to capture the smallest (submicron) particles not captured by the upstream stages. Usually this a high efficiency media filter such as a High Efficiency Particulate Air (HEPA) filter. The high efficiency filter was not included in the present tests.

The current SFS prototype is larger than previously developed prototypes. It uses a more elaborate and effective motorized gear and sprocket system than described in Ref. 1 to drive the take up roll as well as the advance the media in the flow path through multiple driven spindles at the pleat folds.

## IV. Test Method

The following approach was utilized with testing of all three filter elements in the REMS module. Testing was conducted according to a design of experiments matrix shown by Table 1. At the start of each test segment a new data file was established in PACRATS and a new video file for both the front and rear facing cameras was launched. Parameters monitored and recorded included flow rate via the hood flow meter, test article pressure drop, indexing motor power, video during filter media indexing, and test chamber conditions (temperature, relative humidity, and barometric pressure). A voltage-flow rate correlation was determined for each of the target flow rates: 2.0 m<sup>3</sup>/min (70 cfm), 4.2 m<sup>3</sup>/min (150 cfm), and 6.2 m<sup>3</sup>/min (220 cfm).

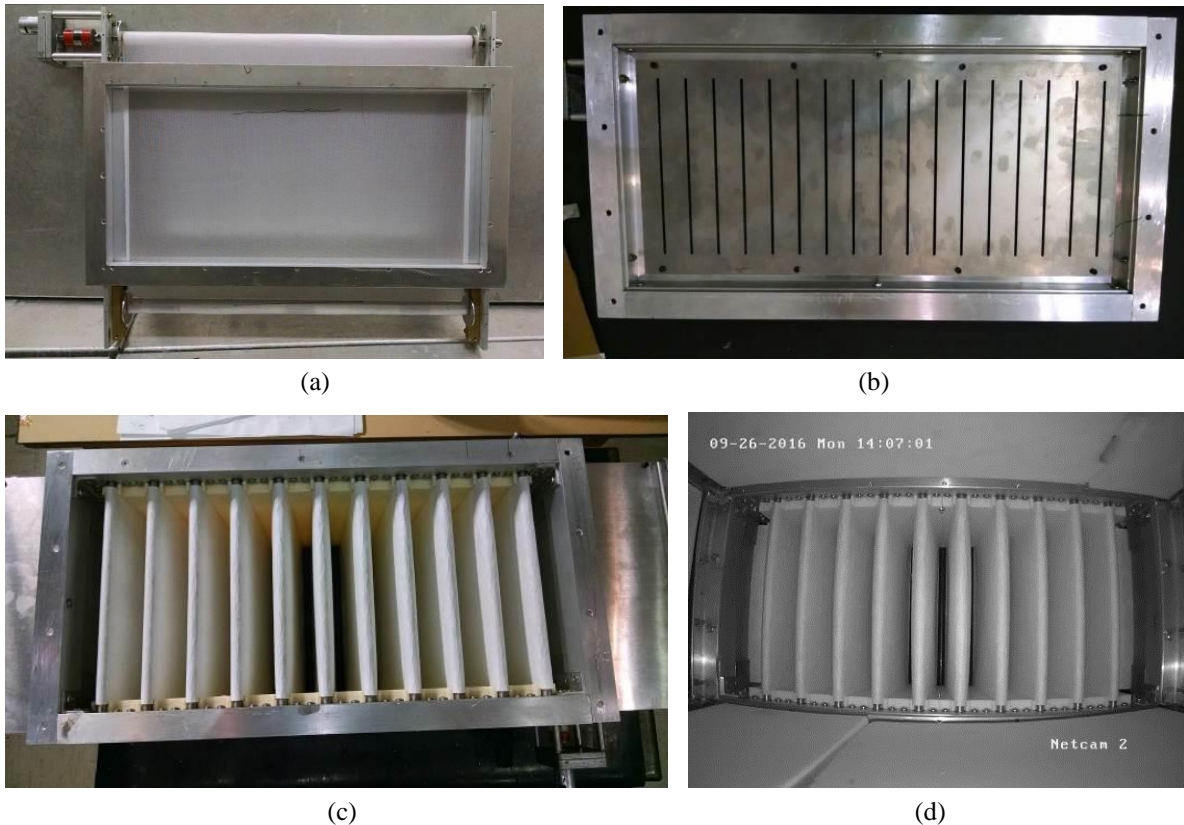

**Figure 3. Scroll Filter System stages.** a) Screen Roll Filter, b) Impactor Filter on inlet side showing slotted face plate, c) Scroll Media Filter showing outlet side, d) Scroll Media Filter as seen from the REMS camera showing the filter outlet.

## V. Results and Analysis

The main tests were conducted in MSFC's REMS facility and installed as described in Section II.

### A. Initial Tests

The filter media used in these tests were provided by the filter manufacturer Hollingsworth and Vose (H&V), which provided sample rolls of the media. A heating, ventilation, and air conditioning (HVAC) grade media with a nominal 60% efficiency and 600 Pa (4.5 mm H<sub>2</sub>O) pressure drop at 5.3 cm/s media velocity was used in the initial tests. Table 2 provides the results of the first set of tests conducted in the REMS facility. Three nominal volumetric flow points were selected. The configuration options evaluated by the test matrix were the following:

- 1) Configuration #1 consisting of all three SFS components, (i.e. the SRF, the impactor filter and the SMF.)
- 2) Configuration #2 consisting of the SMF only
- 3) Configuration #3 consisting of the impactor filter only

A total of 15 nominal runs were performed as prescribed by the Design of Experiment guidelines. Test run 9 could not be completed because of issues with media leakage which will be discussed later. It should be noted that the actual measured flow rates varied slightly from the target flow rates in the test matrix of Table 1.

The data from Table 2 are presented graphically in Figs. 4 and 5. The data show that the filter system had an overall air resistance or pressure drop under 149 Pa, with the Impactor filter and SFM each contributing about half of the pressure drop. An indirect measurement of the pressure drop across the SRF can be found from the difference in pressure drop between configuration 1 and the sum of configurations 2 and 3. The data in Fig. 4 seems to indicate that the SRF does not contribute to the overall system pressure drop except at the highest flow rate (6.2 m<sup>3</sup>/min). At this flow rate, the SRF produced a pressure drop of approximately 17.4 Pa compared to the total system pressure drop, of about 140 Pa.

**Table 1. Filter testing matrix.**

RUN	MODE <sup>a</sup>	CONFIGURATION <sup>b</sup>	FLOW <sup>c</sup>
1	1	1	1
2	1	1	2
3	1	1	3
4	1	2	1
5	1	2	2
6	1	2	3
7	2	2	1
8	2	2	2
9	2	2	3
10	1	3	1
11	1	3	2
12	1	3	3
13	2	3	1
14	2	3	2
15	2	3	3

a. Mode: 1=static; 2=indexing

b. Configuration: 1=all 3 elements; 2=scroll only; 3=impactor only

c. Target Flow: 1=2.0 m<sup>3</sup>/min; 2=4.2 m<sup>3</sup>/min; 3=6.2 m<sup>3</sup>/min

**Table 2. Summary of Scroll Filter System test data obtained in the REMS facility.**

Run No.	Mode Level	Configuration Level	Flow Level	Flow Rate (m <sup>3</sup> /min)	Pressure Drop (Pa)	Temperature (C)	Relative Humidity (%)	Barometric Pressure (atm)	Indexing Motor Power	Notes
1	1	1	1	2.07	17.68	30.09	34.13	1.46		Index screen only
2	1	1	2	4.98	71.46	30.16	33.83	1.45		Index screen only
3	1	1	3	5.99	137.45	30.17	33.79	1.45		Index screen only
4	1	2	1	1.95	11.45	30.29	33.14	1.43	N/A	
5	1	2	2	4.45	34.61	30.30	33.11	1.43	N/A	
6	1	2	3	6.22	57.02	30.31	33.06	1.43	N/A	
7	2	2	1	1.91	10.96	30.07	38.55	1.64		Index media fully across face
8	2	2	2	4.06	39.59	30.06	38.66	1.65		Index media fully across face
9	2	2	3							Index media fully across face
10	1	3	1	2.01	2.49	30.52	32.92	1.44	N/A	
11	1	3	2	4.26	26.89	30.52	32.89	1.44	N/A	
12	1	3	3	6.10	67.23	30.52	32.86	1.44	N/A	
13	2	3	1	1.99	2.49	30.52	32.82	1.44		Index belts fully across face
14	2	3	2	4.12	27.14	30.52	32.81	1.44		Index belts fully across face
15	2	3	3	6.05	66.73	30.52	32.8	1.43		Index belts fully across face

Two Mode levels: static (1), indexing (2)

Three configuration levels: all 3 elements (1), scroll only (2), impactor only (3)

Three flow levels: 2 (1), 4.2 (2), 6.2 (3)

Test 9: Excessive media bowing and leakage and could not be tested.

Although the plots were limited to three test points, a few trends were observed. First, the data in configuration 1, all three elements, shows a possible transition where the rate of pressure drop increases significantly. Specifically, the rate of pressure drop rise from 4.2 m<sup>3</sup>/min to 6.2 m<sup>3</sup>/min was significantly larger than the rise from 2.0 m<sup>3</sup>/min to 4.2 m<sup>3</sup>/min. However, in the other configurations (2 and 3) an approximate linear pressure drop trend was observed for the SMF and only a slight rate increase in pressure drop rise was found for the Impactor Filter for the latter range. Since the SMF seems to produce a nearly linear increase in pressure drop, the non-linear trend could be due to the Impactor filter and the SRF or their interactions with the SMF.

The pressure drop was also monitored during the media scrolling and impactor band regeneration process. Figure 5 presents a comparison of the pressure drop data during static and scrolling operations, and during static and impactor band regeneration operation for the impactor. The data shows that at a nominal flow rate of 2.0 m<sup>3</sup>/min, the pressure drop did not change appreciably when the media was scrolled, while at 4.2 m<sup>3</sup>/min the pressure drop actually rose above its static value. For the impactor, the static and in-situ regeneration modes provide very similar pressure drop values for all flow rates. These data indicated that the media scrolling operation produced off-nominal effects, while the impactor performance was not affected by the regeneration process.

One of the issues observed with the SMF was the ballooning of the filter media under the hydrodynamic load. The media was observed on video, viewed internally from within the duct, to stretch, deform, and balloon as the flow increased beyond 2.0 m<sup>3</sup>/min. And this happened almost from the onset of flow conditions, within minutes of the start of the test run. Images of the condition of the filter media in the SMF at different flow rates are shown in Fig. 6. Up to a flow rate of 2.0 m<sup>3</sup>/min, the media does not appear to deform or stretch noticeably (compare Fig. 6a to Figs. 6b and 6c). At a flow rate of 4.2 m<sup>3</sup>/min, the media has ballooned to some degree (see Fig. 6b), and at 6.2 m<sup>3</sup>/min an even more pronounced ballooning effect was observed (Fig. 6c). Media ballooning is accompanied by the media coming loose from the guides or tracks and effectively leaking at the edges of the media. Finally, Fig. 6d shows that the ballooning effect did not significantly alter the media after the flow was stopped.

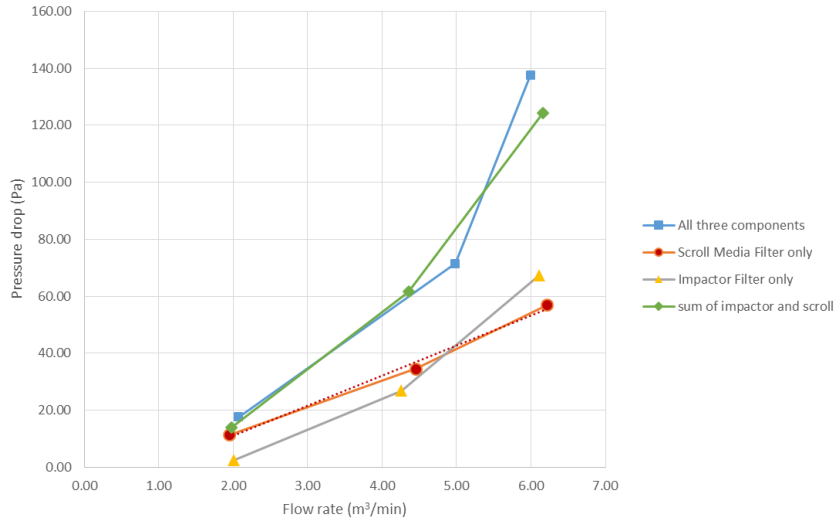

**Figure 5. Pressure drop during static operations.**

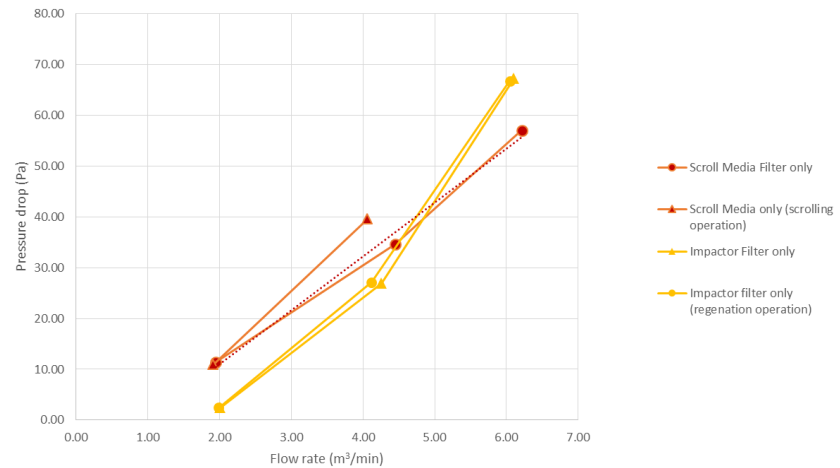

**Figure 4. Filter pressure drop during media scrolling and band regeneration operations.**

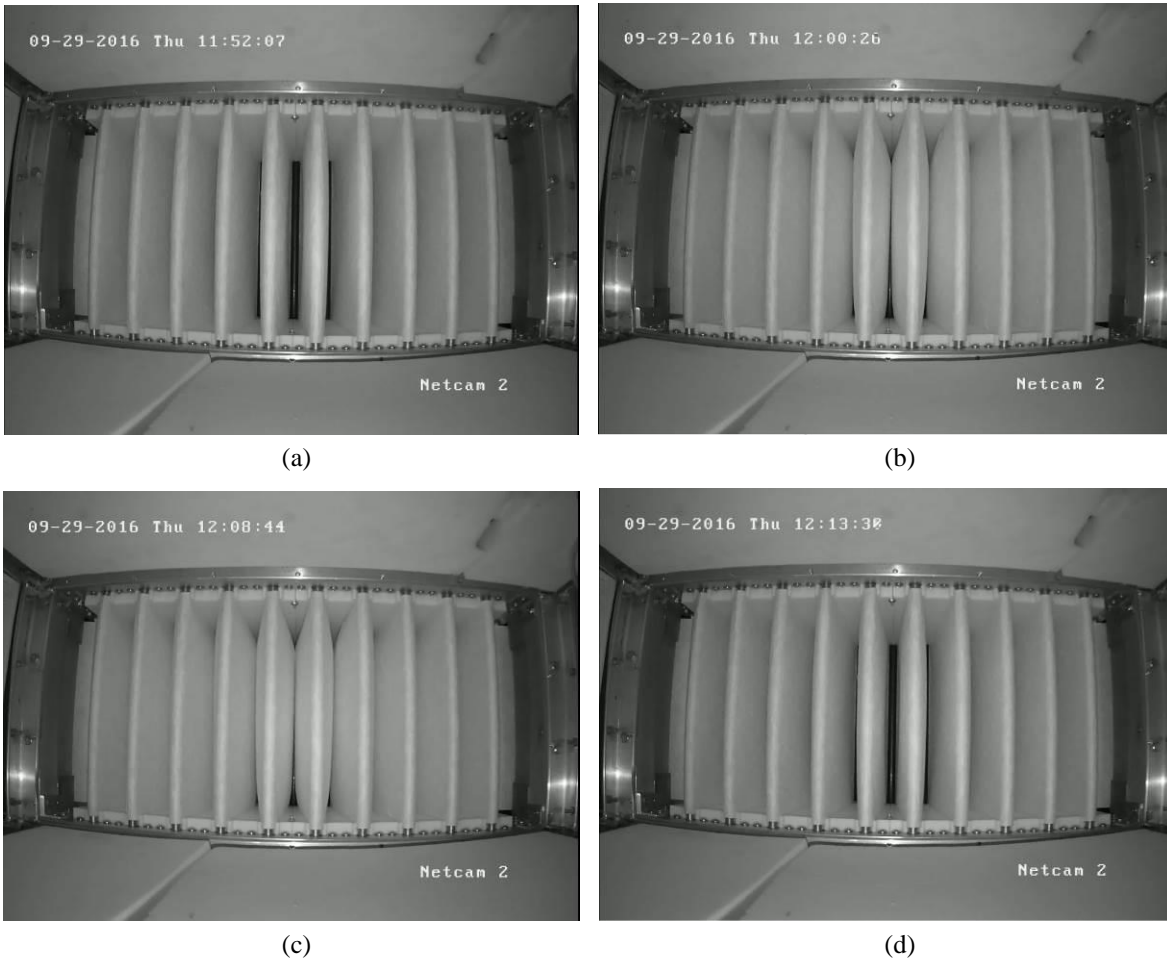

**Figure 6. Video still images of the SMF in the REMS module. a) 2 m<sup>3</sup>/min, b) 4.2 m<sup>3</sup>/min, c) 6.2 m<sup>3</sup>/min, and d) no flow.**

As stated, the ballooning of the media led to a seal failure event where significant leakage occurred at the edges because the media became unseated from the guides. As a result, the media underwent some stretching with an accompanying loss of tension at the top and bottom edges that led to additional edge leakage effects. Fraying of the edges of the media due to its forceful interactions “jumping” over at the track guides also had adverse effects on the scrolling operation. At 2.0 m<sup>3</sup>/min, after an initial scrolling operation, the motor stalled due to increased resistance in advancing the media likely due to the frayed edges. An attempt was made to reset the media by hand by rewinding some of it back on the supply spool. This resulted in a nominal scroll operation at 2.0 m<sup>3</sup>/min. However, when the same was attempted for the 4.2 m<sup>3</sup>/min case, the media again became unseated within one minute of scrolling and this operation could not be resolved satisfactorily.

The media ballooning effect may have also been a factor in producing the higher pressure drop measured during media scrolling at 4.2 m<sup>3</sup>/min. Judging from the visual condition of the media in Fig. 6b, it is surmise that the ballooning of the media could have created a flow blockage effect where a portion of the media surfaces from adjacent pleats came into contact partially obstructing the flow path through the filter. While this effect should have been present during static operation, the scrolling operation exacerbated the effect by unseating the media from the guides and bringing the pleated surfaces even closer together.

Further tests with the SMF could not effectively be achieved after test point 8. Therefore test point 9 was not attempted. The scroll filter assembly was removed for evaluation and a modified unit was subsequently provided by the developers at the NASA GRC.



## B. Hardware modification and retesting of the Scroll Media Filter

To mitigate the effect of media ballooning and deformation the SMF was modified to include screen panel supports on the back side of each pleat. A picture the SFM with the screen supports is shown in Fig. 7.

The new design modification was tested at the GRC in the setup shown in Fig 1b. An available higher grade filter media rated at a pressure drop of 1.53 kPa (11.5 mm H<sub>2</sub>O) at 5.3 cm/s media velocity was used. A plot of the filter's hydrodynamic performance at the GRC is given in Fig. 8. The flow rate was controlled manually by varying the voltage level on the variable AC power transformer connected to the blower. The flow rate was first stepped up to multiple increasing values and subsequently stepped down to a few more decreasing values. The pressure drop rises very linearly with flow rate. The linearity of the graph and the alignment of decreasing values strongly indicates that the hydrodynamic load, even at the highest flow rates tested, did not affect the integrity of the media and the sealing of its edges against the walls of the tracks. Had there were still been sealing issues the curve would have been expected to deviate from the linear trend, particularly at the higher flow rate, due to edge leakage effects and media blockage effects as described previously.



Figure 7. View of SMF with pleat screen supports.

Additional tests were performed at GRC to assess the in-place media scrolling operation under flow conditions. Based on the pressure drop measurement, at 2.8 m<sup>3</sup>/min (100 cfm), the sealing at the edges of the media appeared to

become tighter (i.e. slight higher pressure drop). In this case, the pressure drop rose slightly by less than 2% and remained that way after the scrolling of the media had stopped. At 6.2 m<sup>3</sup>/min, on the other hand, the pressure drop went down slightly by about 1%. Based on these small variations in pressure drop during the scrolling operation, there is some confidence that in-place media changes during nominal operations will be acceptable.

The Scroll Media Filter was retested in the REMS facility using the higher grade media and showed similar performance improvements as found in the GRC tests. The flow rates measured in the REMS module were found to be somewhat higher than in the GRC tests. Additional tests are planned to ascertain the discrepancy in the two sets of measurements. The hydrodynamic performance for the two media tested in the REMS facility are shown in Fig. 9. The higher efficiency media which was tested after the hardware modification showed a more linear response to increasing flow rate than the HVAC media tested prior to the modification. This gave a clear indication that the screen pleat supports resulted in better edge sealing which translates into better filter performance. As expected, the higher efficiency media produced a larger pressure drop.

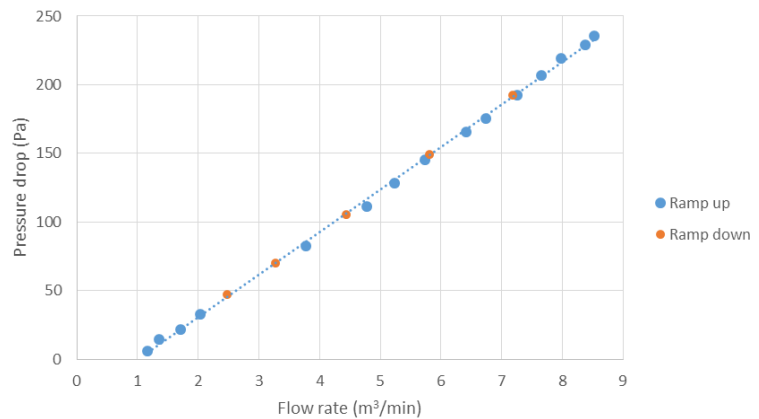

Figure 8. Pressure drop data for the modified SMF during bench-top testing.

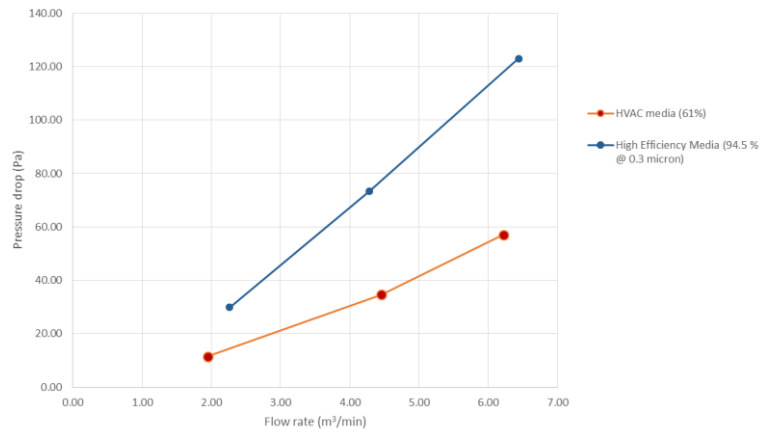

Figure 9. Comparison of filter media in the REMS facility tests.

## VI. Conclusions

The SFS is a developmental filter that was performance tested within the NASA REMS facility at MSFC. The performance of the filter system was assessed under flight like interfaces and flow conditions. The hydrodynamic performance data showed that the filter system had an overall air resistance or pressure drop under 140 Pa (0.6 inches H<sub>2</sub>O) at a flow nominal flow rate of 6.2 m<sup>3</sup>/min with an HVAC grade media. The Impactor filter and the SMF each contributed about half of the pressure drop for flow rates up to 6.2 m<sup>3</sup>/min, but while the SMF exhibited a linear pressure drop rise the Impactor filter produced a non-linear rise. The pressure drop across mesh screen of the SRF was minimal and only contributed at the highest, 6.2 m<sup>3</sup>/min, flow rate. The ballooning effect of the SMF filter media resulted in off-nominal performance with higher pressure drops and ineffective scrolling operation. Modification using pleat screen support panels provided effective mitigation of the ballooning effects in bench tests performed at GRC and subsequent tests in the NASA REMS module.

## Acknowledgements

We would like to acknowledge the filter and mechanism designs provided by Mechanical Engineer Dan Gotti of ARA which were vital in the development of the current SFS prototypes. The policy of NASA is to not promote or endorse or appear to promote or endorse a commercial product, service or activity. The use of the various product names presented in the paper does not imply endorsement.

## References

<sup>1</sup>Agui, J.H. and Vijayakumar, R., "Development of an Indexing Media Filtration System for Long Duration Space Missions," AIAA-2013-3486, *43<sup>rd</sup> International Conference on Environmental Systems*, Vail, Colorado, 2013.

<sup>2</sup>Agui, J.H. and Vijayakumar, R., "Characterization of a Regenerable Impactor Filter for Spacecraft Cabin Applications," ICES-2015-206, *45<sup>th</sup> International Conference on Environmental Systems*, Bellevue, Washington, 2015

<sup>3</sup>Agui, J., Vijayakumar, R. and Perry, J., "Particulate Filtration Design Considerations for Crewed Spacecraft Life Support Systems," ICES-2016-93, *46<sup>th</sup> International Conference on Environmental Systems*, Vienna, Austria, 2016.