

The Effectiveness of Shrouding on Reducing Meshed Spur Gear Power Loss – Test Results

By

I. R. Delgado, NASA

and

M. J. Hurrell, HX5 Sierra LLC

The Effectiveness of Shrouding on Reducing Meshed Spur Gear Power Loss – Test Results

I. R. Delgado, NASA and M. J. Hurrell, HX5 Sierra LLC

Abstract

Gearbox efficiency is reduced at high rotational speeds due to windage drag and viscous effects on rotating, meshed gear components. A goal of NASA aeronautics rotorcraft research is aimed at propulsion technologies that improve efficiency while minimizing vehicle weight. Specifically, reducing power losses to rotorcraft gearboxes would allow gains in areas such as vehicle payload, range, mission type, and fuel consumption. To that end, a gear windage rig has been commissioned at NASA Glenn Research Center to measure windage drag on gears and to test methodologies to mitigate windage power losses. One method used in rotorcraft gearbox design attempts to reduce gear windage power loss by utilizing close clearance walls to enclose the gears in both the axial and radial directions. The close clearance shrouds result in reduced drag on the gear teeth and reduced power loss. For meshed spur gears, the shrouding takes the form of metal side plates and circumferential metal sectors. Variably positioned axial and radial shrouds are incorporated in the NASA rig to study the effect of shroud clearance on gearbox power loss. A number of researchers have given experimental and analytical results for single spur gears, with and without shrouding. Shrouded meshed spur gear test results are sparse in the literature. Windage tests were run at NASA Glenn using meshed spur gears at four shroud configurations: unshrouded, shrouded (max. axial, max. radial), and two intermediate shrouding conditions. Results are compared to available meshed spur gear power loss data/analyses as well as single spur gear data/analyses. Recommendations are made for future work.

The Effectiveness of Shrouding on Reducing Meshed Spur Gear Power Loss – Test Results

I. R. Delgado, NASA and M. J. Hurrell, HX5 Sierra LLC

Introduction

Rotorcraft gearboxes are critical in efficiently transferring power from the turboshaft jet engine to the main and tail rotors for conventional helicopters. Efficiencies of 95 to 97 percent are common [1], and they are also used in fixed wing aircraft such as geared turbofans and the VTOL (Vertical Take-Off and Landing) V-22 Osprey. With ever-increasing fuel costs for air transportation, research is focused on demonstrating and maturing alternative and more efficient means of propulsion while minimizing aircraft weight [2]. This includes gearbox materials that improve overall life, alternative power transmission concepts that increase power density, reductions in gearbox form factor, as well as innovative lubrication methods that reduce the amount of required lubricant or means of cooling. One area of active research is in minimizing gearbox windage for rotorcraft transmissions. Gear windage power loss (WPL) reduces the efficiency of the transmission due to drag on the gear teeth at high surface speeds. Not only is windage drag detrimental to gearbox efficiency, but the increased friction generates additional heating in the gearbox, thereby placing more demand on cooling requirements. Dudley [3] highlights a number of points concerning WPL for gearboxes: 1) windage losses become significant above 10,000 fpm; 2) the use of 'oil shields' as shrouds to reduce WPL; 3) the need to keep oil from building up within the casing; 4) The use of 'oil strippers' to shield discharge ports; 5) WPL decreases with increasing oil inlet temperature; 5) additional losses occur due to oil becoming trapped in the mesh.

Gearbox power losses can be divided into load-dependent and load-independent losses. Load-dependent losses are friction-related such as meshing of the gear teeth or contact between bearing surfaces. Sources of load-independent losses are those due to bearings, seals, gear windage, gear churning, and gear mesh pocketing losses [4]. This paper focuses on shrouding for mitigating spur gear WPL in an air/oil environment.

Experiments in air by Dawson [5] show a nearly 50% decrease in WPL, relative to the unshrouded configuration, for a spur gear shrouded with a 0.59 in. (15 mm) radial clearance over a 270° sector and a 1.06 in. (27 mm) axial clearance. Collaborative work by Handschuh and Hurrell [6] and Hill [7] show a decrease in WPL for a single shrouded spur gear when compared to its unshrouded configuration. Experimentally, Handschuh shows a ~30% decrease in WPL at 25,000 ft./min. (127 m/s) for a 13 in. (330.2 mm) pitch diameter spur gear with a 1.0 in. (25.4 mm) face width in the shrouded (0.66 in. (16.7 mm) radial, 1.2 in. (30.2 mm) axial clearance) configuration. CFD work by Hill [7] and others was able to show consistency with the test data from that test configuration as well as three additional configurations.

Lord [8] observed a ~80% decrease in WPL for a shrouded (0.039 in. (1 mm) axial and radial clearance) 7.9 in. (200 mm) pitch diameter, 1.6 in. (40 mm) face width spur gear at 25,000 ft./min. (127 m/s), in air, and compared it to test data in the unshrouded configuration. However, he observed an order of magnitude increase in WPL when testing the shrouded gear in an 'oil injection' environment compared to the air only environment. Dawson [5] notes the potential for this increase in WPL in discussing his series of spur gear experiments in air. CFD analyses by Chaari et al. [9] on a single spur gear indicate an order of magnitude increase in WPL at 20,000 rpm (2094 rad/s) with a corresponding increase in pressure gradient between gear teeth due to the change in environment from air to an air/oil mixture. An effective density was used for the analysis in an air/oil environment. Single gear multiphase analyses by Kunz et al. [10] also indicate a substantial increase in WPL due to the air/oil environment. Handschuh and Hurrell [6] observed a slight increase in WPL for an unshrouded 13 in. (330) mm pitch diameter spur gear comparing data in an air only environment to an air/oil environment. This increase is notable above 30,000 ft./min. (152 m/s). However, Handschuh reports that the WPL is slightly greater for the maximum axial, maximum radial configuration in an air/oil environment compared to an air only environment while the opposite is observed for the remaining three configurations (i.e. min. radial/max. axial, min. radial/min. axial, max. radial/min. axial).

Experiments by Delgado and Hurrell [11] show a 7x increase in WPL at 25,000 ft./min. (127 m/s) for unshrouded *meshed* spur gears when compared to the *single* unshrouded 13 in. (330 mm) pitch diameter spur gear data from Handschuh and Hurrell [6]. With 0.039 in. (1 mm) axial and radial shroud clearances, a 12x increase in WPL is observed comparing single versus meshed spur gears. Table 1 summarizes the WPL data presented from literature. A windage power loss analytical model on a spur gear pair by

Seetharaman and Kahraman [12] shows good agreement with experimental data on the same gears by Petry-Johnson et al. [13]. Pocketing losses as well as drag losses are modeled.

Table 1 – Comparison of selected spur gear WPL data from literature.

Reference	windage power loss	environment	meshed spur gear?	diametral pitch	face width [in]	speed [ft./min.]	clearance		comments
							radial [in]	axial [in]	
Dawson [5]	53% ↓	air	n	3.175	7.4	?	0.59	1.06	1, 2
Handschuh et al. [6]	~38% ↓	air	n	4	1	25,000	0.66	1.2	2
Lord [8]	~80% ↓	air	n	25.4	1.6	25,000	0.04	0.04	2
Lord [8]	~10X ↑	'oil injected' 0.66 gpm	n	25.4	1.6	25,000	0.04	0.04	3
Delgado et al. [11]	7x ↑	oil jet ~0.7 gpm	y	4	1	25,000	n/a	n/a	4
Delgado et al. [11]	12x ↑	oil jet ~0.9 gpm	y	4	1	25000	0.04	0.04	5

Notes
1) 270° shroud sector
2) WPL comparison relative to unshrouded configuration.
3) WPL comparison relative to shrouded configuration in air.
4) WPL compared to single unshrouded of Handschuh et al. [6]
5) WPL compared to single shrouded of Handschuh et al. [6]

The objective of this work is to compare experimental windage power loss data on meshed spur gears at intermediate shroud conditions with previous shrouded meshed spur gear experiments [11]. Experiments are done at nearly identical oil flows and oil temperatures. Findings by the authors [14] as well as others [3, 8] indicate that WPL is dependent, in part, on oil flow and temperature. Recommendations are given for future research.

Experimental Apparatus

Windage power loss data were collected in NASA's Gear Windage Power Loss Test Facility, Figure 1. The input shaft of the test gearbox is connected to a 150 hp (112 kW) dc drive motor and 1:5.17 speed-increasing gearbox. An opposing torsional load can be applied on the test gear output shaft using the magnetic particle brake rated to 890 in-lb (100 N-m) at 2900 rpm (304 rad/s). Friction clutches (carbon on carbon friction wheels) located forward of the torque meter and brake allow for disengagement of the test gearbox input and output shafts. This enables the test hardware (i.e. shafts, bearings, test gears) to coast-down from a preset pitch-line velocity. Current tests were limited to approximately 28,000 ft./min. (142 m/s). This is approximately 10,000 rpm (1047 rad/s) for an 11 in. (279 mm) pitch diameter pinion.

Tests can be run with and without shrouding. Aluminum plates are used for the axial shrouds while A366 low carbon sheet metal strips are used for radial shrouding, Figure 2. The shrouds are placed within a clam-shell housing, Figure 3. The lower halves of both the drive- and driven-side clam-shell housing contain four oil drain holes, each 0.75 in. (19 mm) wide by 3.5 in. (89 mm) long circumferentially. The shroud surface roughness is approximately 63 μin. (1.6 μm). Six machined slots within the clam-shell housing allow for set clearances between the axial shroud wall and gear. The axial shroud walls, in turn, have six machined slots to vary the radial shroud position, Figures 2 and 4. In order to facilitate assembly of the rig, the clam-shell housing is composed of four pieces: 1) upper drive-side; 2) lower drive-side; 3) upper driven-side; 4) lower driven-side. The entire assembly is mounted within the test gearbox enclosing the test gears, Figure 3. An available clam-shell housing was tested as an intermediate shroud condition to assess windage power loss with additional drain holes and grooves as shown in Figure 2 and Figure 3.

The gear fling-off temperature for all configurations was measured at 30 degrees (0.52 rad.) clockwise, relative to vertical on the drive-side pinion as viewed from the front of the test gearbox, Figure 1, with the torque meter on the right side and the magnetic particle brake on the left side. Lubrication was directed into mesh, nominally at 0.9 gpm (4.1 lpm) at 120 psi (827 kPa). The lubricant used is a synthetic oil used specifically for gas turbine engines and helicopter transmissions and meets U.S. DoD-PRF-85734 specifications [15].

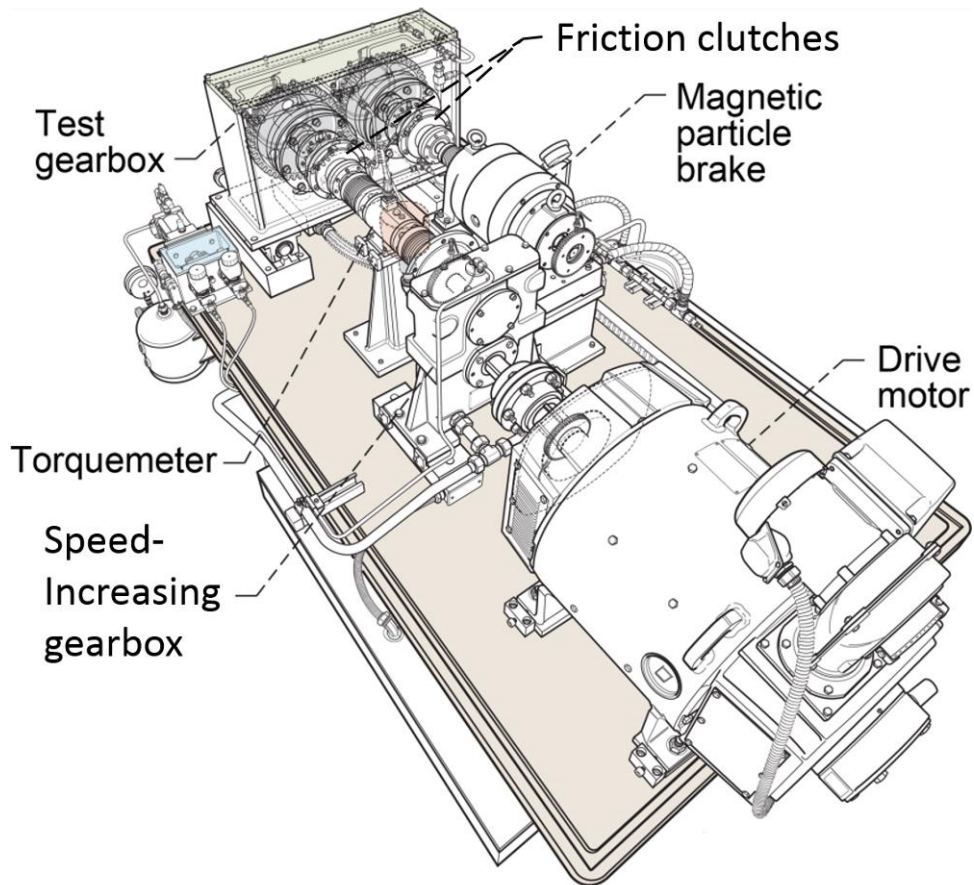

Figure 1 – Schematic of Gear Windage Power Loss Test Facility.

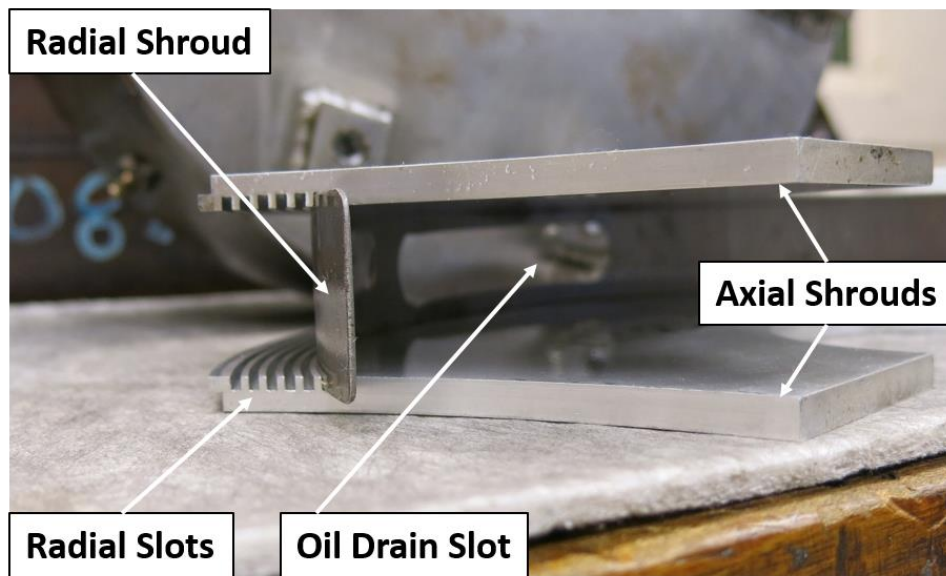

Figure 2 – Configuration of radial and axial shrouding. Axial shrouds are 0.25 in. (6.35 mm) thick.

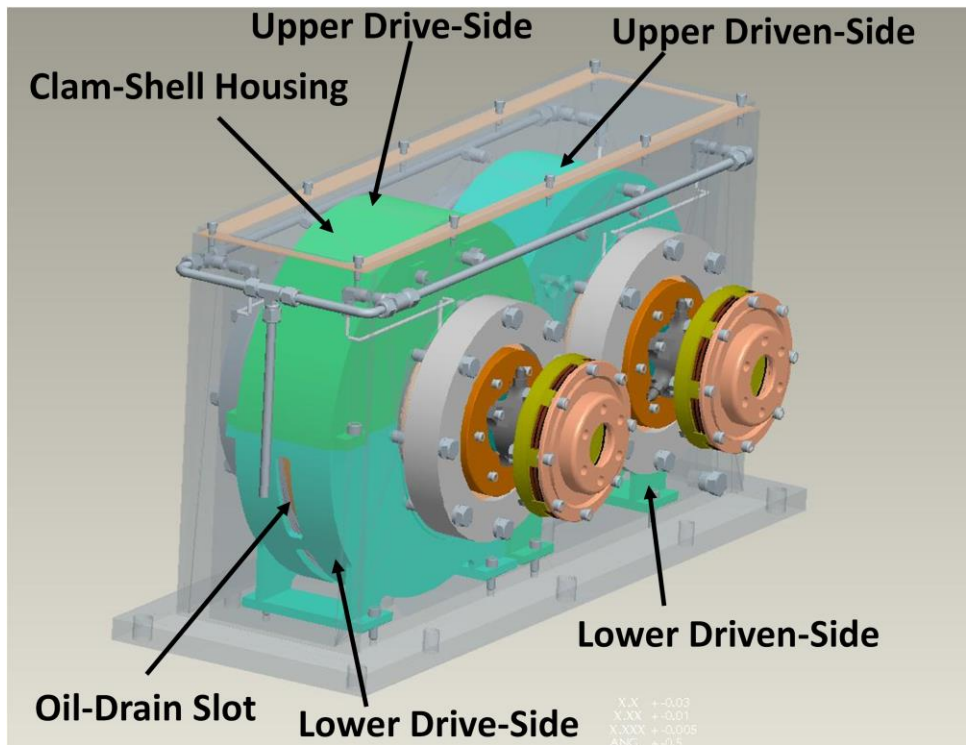

Figure 3 – Test gearbox showing clam-shell (CS) enclosure for shrouding within the NASA Gearbox.



Figure 4 – Configuration of axial and radial shrouding using machined slots. Axial shrouds are 0.25 in. (6.35 mm) thick.

Experimentation

The spur pinion and gear specifications are given in Table 2. Meshed spur gear tests were run in unshrouded and shrouded configurations at an oil inlet temperature of approximately 100°F (38°C). The oil inlet temperature was measured at a point in the stainless steel oil inlet supply approximately 5 ft. (1.5 m) prior to entering the test gearbox. Two unshrouded configurations were tested: unshrouded with no clam-shell housing installed, designated U, and unshrouded with the clam-shell housing installed, designated CS. The U configuration is simply the two meshed spur gears installed in the gearbox. Both the gear mesh lube flow and bearing lube flow were held constant at nominally 0.9 gpm (4.1 lpm) and 0.2 gpm (0.9 lpm), respectively. Gear mesh lubrication was into mesh for all configurations using two 0.125 in. (3.2 mm) o.d. stainless steel tubes with 0.02 in. (0.5 mm) wall thickness. The CS configuration is the U configuration with the clam-shell housing installed. Four shroud configurations were tested. Designations for the shrouded configurations are C36 (max. axial, max. radial, C1 (min. axial, min. radial), C31 (max. axial, min. radial), and C6 (min. axial, max. radial). Table 3 provides the clearances for the unshrouded and shrouded configurations. Figure 5 shows the 0.039 in. (1 mm) axial and radial shrouding configuration with drain slots on both the drive and driven side prior to assembly. For all shroud configurations, drain slots were approximately 3.5 in. (89 mm) long circumferentially by (0.75 in.) 19 mm wide.

All tests were run with a 10 in-lb (1.1 N-m) counter-torque to prevent gear tooth disengagement during rotation. The meshed spur gears were rotated to 10,000 rpm in 2000 rpm increments. The speed was changed every 100 seconds with approximately 20 seconds used to transition to the next speed increment and 80 seconds to hold at speed. After holding at the 10,000 rpm-condition, the drive motor and dynamometer are simultaneously disengaged allowing the test gears, input shaft, and output shaft to coast-down. This process was repeated for a total of three cycles. An example ramp-up and wind-down cycle is shown in Figure 6. Data was recorded at 3 Hz, capture rate.

Test data was taken for the U, C6, C31, and C36 configurations while data from [11] was used for the C1 and CS configuration. Third cycle data is compared for all six configurations.

Table 2 – Pinion (drive-side) and gear (driven-side) specifications.

Gear Parameter	Drive-side	Driven-side
number of teeth	44	52
pitch/mod., 1/in. (mm)	4 (6.35)	
face width, in. (mm)	1.12 (28.4)	1.12 (28.4)
pitch dia., in. (mm)	11.0 (279.4)	13.0 (330.2)
pressure angle, deg (rad)	25 (0.44)	
outside dia., in. (mm)	11.49 (291.9)	13.49 (342.7)
Material	Steel-SAE 5150H	
surface finish, μ in (μ m)	16 (0.4)	

Table 3 – Nominal shroud configuration clearances.

Shroud Configuration	Axial Clearance	Radial Clearance	
	Per side in. (mm)	Drive-side in. (mm)	Driven-side in. (mm)
(U) unshrouded	2.25 (57)	2.5 (64)	1.0 (25)
(CS) unshrouded with clam-shell housing	1.5 (38)	0.82 (21)	0.82 (21)
(C1) shrouded	0.039 (1)	0.039 (1)	0.039 (1)
(C6) shrouded	0.039 (1)	0.66 (17)	0.66 (17)
(C31) shrouded	1.17 (30)	0.039 (1)	0.039 (1)
(C36) shrouded	1.17 (30)	0.66 (17)	0.66 (17)

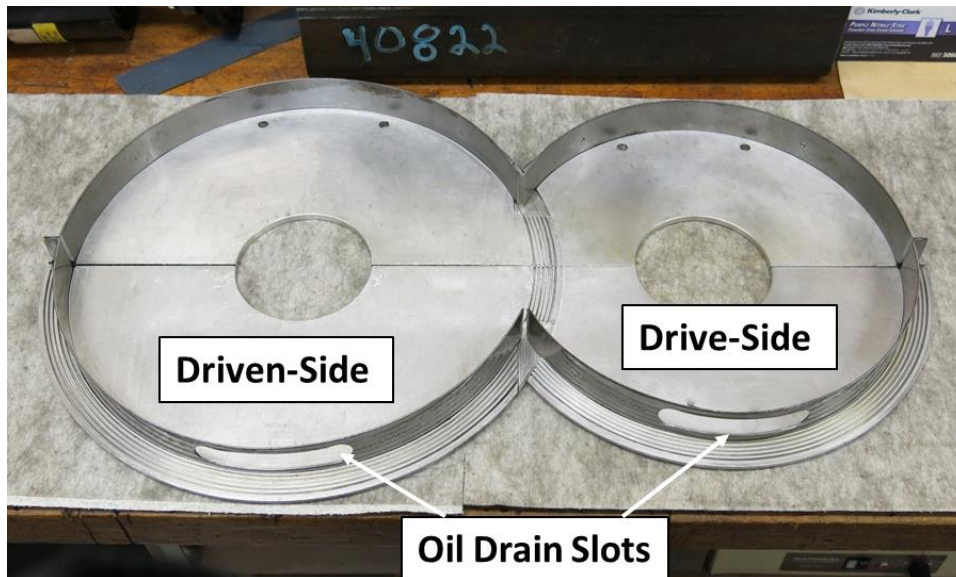

Figure 5 – C1 shroud configuration with drain slots.

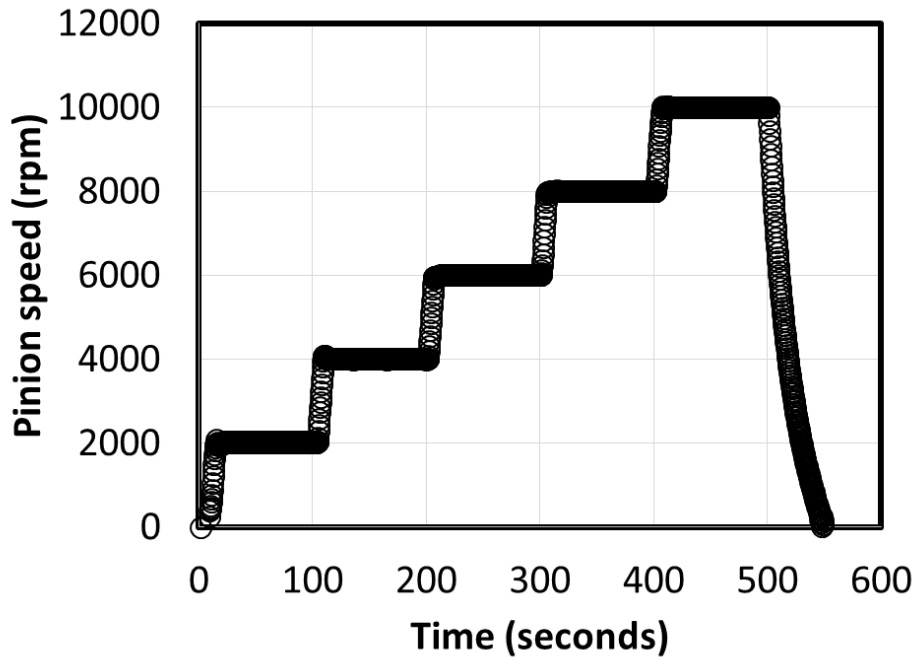

Figure 6 – Example windage test ramp-up and wind-down cycle.

Gear Windage Power Loss Calculation

The total power loss consists of gear mesh losses, rig driveline losses, and windage losses. Considering the light loading of the gear set during the tests reported herein, the gear mesh losses are minimal. Gear mesh losses are conservatively calculated to be 0.14 hp (0.1 kW) average at 10 in-lb. (1.1 N-m) torque over the meshing cycle, based on analyses by Anderson and Loewenthal [16]. Alternative meshing loss calculations due to sliding and rolling were found to be negligible [17]. The rig driveline losses, or tare losses, consist of power losses associated with the spinning drive shaft, driven shaft, and support bearings. These losses were determined by performing coast-down tests without the test gears installed. The tare windage power loss for the drive shaft and bearing assembly was experimentally determined at each test temperature. The driven shaft and bearing assembly tare windage power loss were assumed to be the same since both shafts are nearly identical, with the exception of the gear spline diametral pitch.

Similar to Dawson [5], power loss due to windage was calculated, in part, by plotting the angular velocity versus time curve during free deceleration and measuring the slope or instantaneous angular acceleration at various points on that curve. Torque is given by the product of the angular acceleration and the moment of inertia. An equivalent moment of inertia, J_{eq} , for the meshed gear system is given by Equation 1 [Ref. 18]. The power (or windage power loss) of the meshed gear system is calculated from the product of the torque and the shaft speed. Finally, the windage power loss due the gears alone is given by subtracting the tare power losses and gear mesh losses from the power loss of the meshed gear system.

$$J_{eq} = J_1 + J_2 \left(\frac{N_1}{N_2} \right)^2 \quad \text{Equation 1}$$

- where
- J_1 = moment of inertia of the pinion
 - J_2 = moment of inertia of the gear
 - N_1 = number of pinion teeth
 - N_2 = number of gear teeth

Component inertias were measured using the curved rail method outlined by Genta and Delprete [18]. Figure 7 shows the experimental setup for the curved rail procedure. The test shaft assemblies, drive and driven, were assembled with and without the test gears. The inertias measured using the test shaft assemblies without the test gears are used in calculating the rig driveline losses. The inertia, J , given by Equation 2 are measured using the test shaft assemblies with the test gears and are used in determining the gear windage losses.

$$J = mr^2 \left[\frac{gT^2}{4\pi(R-r)} - 1 \right] \quad \text{Equation 2}$$

where J = moment of inertia of the assembly

m = total mass of the assembly

r = radius of shaft bearing journal

R = radius of curved rail of test apparatus

T = period of oscillation of assembly

g = gravitational constant



Figure 7 – Example experimental setup for tare loss calculation using curved rail method.

Discussion and future work

Figure 8 shows example WPL data for a shrouded configuration for three consecutive wind-down cycles. The WPL values decrease slightly with each successive wind-down cycle. This is due to increasing air/oil temperatures within the gearbox, caused by the rotating meshed spur gears. Experience with the test rig over several test configurations has shown that with each successive cycle, the difference in WPL compared to the preceding cycle is progressively less. Although it is likely that WPL values would decrease further with increasing cycles, a three-cycle test procedure was used to maintain data consistency and test efficiency.

Table 4 shows average values of oil inlet temperature, oil exit temperature, gear oil flow and bearing oil flow for the six tested shrouded/unshrouded configurations. Approximately 100 data points were averaged for each value. Recall from Figure 6 that approximately 30 to 40 seconds of data at 3 Hz are used during coast-down from 10,000 rpm. Average oil inlet temperatures ranged from 101°F (38°C) to 109°F (43°C). Average oil exit temperatures varied from 137°F (58°C) to 163°F (73°C). The oil exit

temperatures for the shrouded configurations (C1, C6, C31, and C36) were noticeably lower, 10°F to 20°F (-6°C to 11°C), than the unshrouded configurations (U and CS). Gear inlet oil flow rates ranged from 0.85 gpm (3.86 lpm) to 1.07 gpm (4.86 lpm) while bearing inlet oil flow rates varied from 0.14 gpm (0.64 lpm) to 0.27 gpm (1.23 lpm). Research has shown the variation in WPL with both oil temperature and flow rate. Thus, an effort was made to control, to the extent possible, both parameters for these data sets.

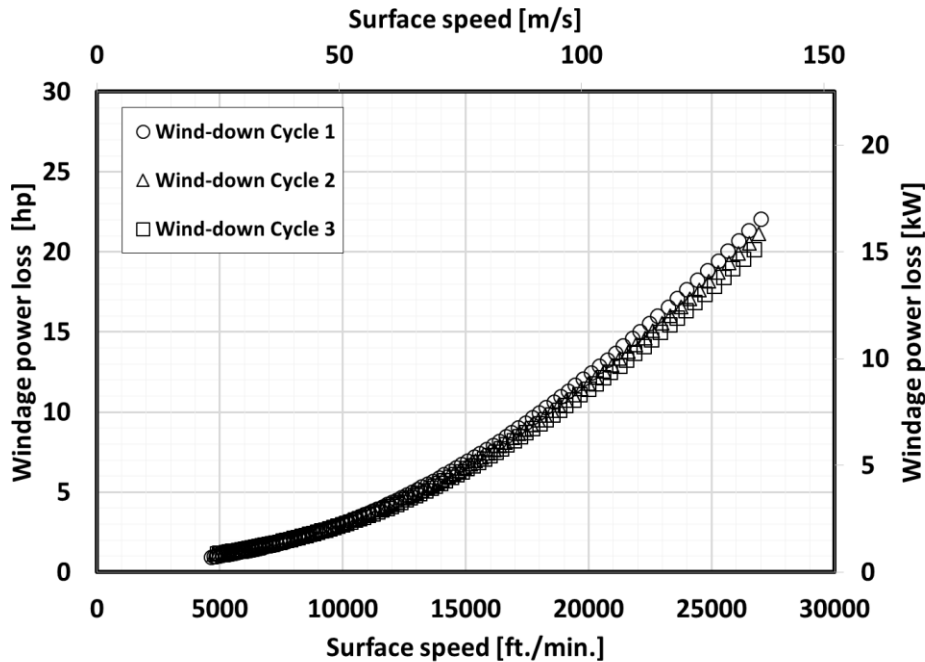

Figure 8 – Example WPL data set showing three wind-down cycles.

Table 4 – Average ‘Cycle 3 wind-down’ oil temperatures and flows for various shroud configurations.

Shroud Configuration	oil inlet temp.		oil exit temp.		gear inlet oil-flow		bearing inlet oil-flow	
	°F	(°C)	°F	(°C)	gpm	(lpm)	gpm	(lpm)
(U) unshrouded	107	(41)	163	(73)	0.91	(4.1)	0.27	(1.2)
(CS) unshrouded with clam-shell housing	102	(39)	162	(72)	0.90	(4.1)	0.14	(0.6)
(C1) shrouded	109	(43)	143	(62)	0.91	(4.1)	0.18	(0.8)
(C6) shrouded	107	(41)	151	(66)	0.91	(4.1)	0.19	(0.9)
(C31) shrouded	101	(38)	137	(58)	1.07	(4.9)	0.18	(0.8)
(C36) shrouded	101	(38)	144	(62)	0.85	(3.9)	0.19	(0.9)

WPL measurements are shown in Figure 9 for the configurations given in Table 3. Below 15,000 ft./min. (76 m/s), WPL values are essentially identical, regardless of shroud configuration or lack thereof. This is in line with findings by other researchers that WPL is relatively insignificant below approximately 10,000 ft./min. (51 m/s) [19, 20]. Above 10,000 ft./min. (51 m/s), the unshrouded and CS configurations give the highest WPL values observed, followed by the C6, C36, and C1 configurations. At 25,000 ft./min. (127 m/s) the reduction in WPL is 10% between the unshrouded (U, CS) and shrouded (C6, C36, and C1) configurations. There was little difference observed in WPL between the C6, C36, and C1 configurations. Previous single spur gear studies in both air only [5-8, 10] and air/oil [6] have shown measurable differences in WPL with the minimum axial/radial clearances generally having the greatest reduction in WPL.

The largest reduction (29%) in WPL were observed for the C31 configuration (max. axial, min. radial). This experiment was repeated to check consistency of the results, Figure 10. Recall that previous shrouded single gear experiments by Handschuh [6] show that the largest reductions in WPL occur at the minimum axial and minimum radial clearance configuration, followed by the minimum axial/maximum radial clearance configuration and the maximum axial/minimum radial shroud clearance configuration. Data by Lord [8] for a single gear show a decrease in WPL with increased radial shroud clearance 0.039 in. to 0.200 in. (1 to 5 mm) while holding the axial clearance at 0.039 in. (1 mm) at a constant oil flow rate. However, holding the radial clearance at 0.039 in. (1 mm) while changing the axial clearance from 0.039 in. to 0.200 in. (1 to 5 mm) at constant oil flow rate resulted in a slight increase in WPL.

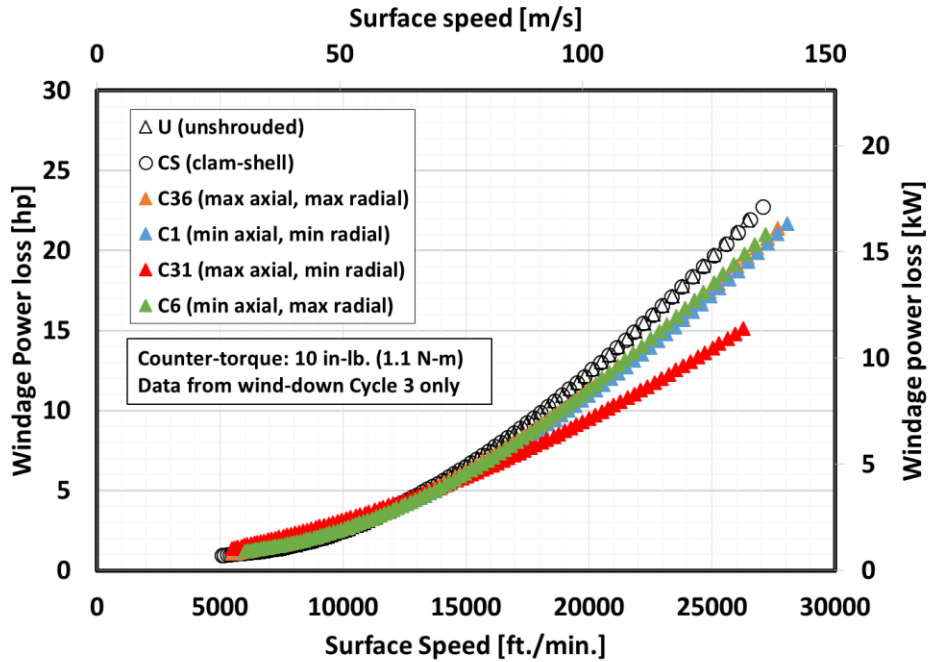

Figure 9 – Comparison of meshed spur gear windage power loss versus shroud configuration.

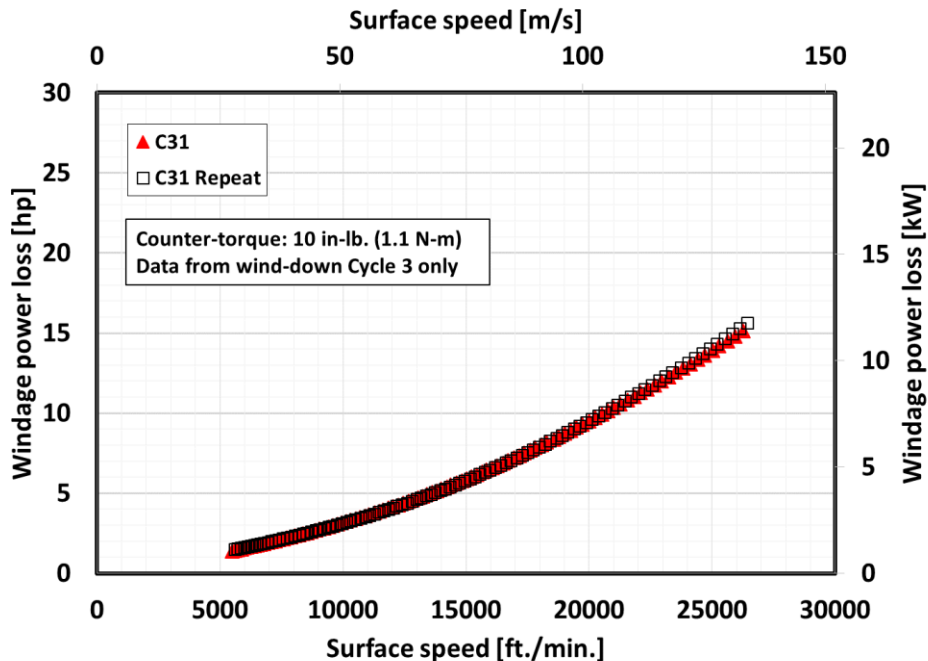

Figure 10 – Repeat WPL data for C31 configuration (max. axial/min. radial).

The substantial improvement in WPL reduction for the maximum axial, minimum radial shroud condition shows a need for further research. Earlier work by the authors [11] indicated a more than doubling of the WPL when comparing data between single and meshed spur gears. For the unshrouded case, this difference was approximately 7x. For the shrouded case, an even greater increase of 12x was observed. Two promising areas for further research include pocketing losses [12] and high velocity axial fluid flow at the meshing region [21].

Further, although the results are specifically for spur gears, in principle, there is potential to improve WPL for differing types of gear meshes (i.e. helical, spiral bevel, face) for helicopter gearboxes particularly above 15,000 ft./min. For example, the V-22 transmission contains helical gear meshes rotating in excess of 20,000 ft./min. [22]. The OH-58 contains a two-stage helical gear reduction from the turboshaft engine, reducing the output shaft speed from 35,000 rpm to 6000 rpm at the input to the main gearbox. Also, the UH-60 main rotor transmission contains a spiral bevel gear reduction at an input shaft speed of 21,000 rpm [23].

Future work is needed to determine the effect on WPL of out-of-mesh lubrication, oil jet size and flow, as well as oil drain hole geometry and location. These parameters were held constant for the results given above. Out-of-mesh lubrication experiments would address gear cooling needs in relation to WPL improvements using shrouds. Previous work by the authors [14] with the same experimental setup have demonstrated increased WPL with in-to-mesh lubricant flow. Those same set of experiments have also demonstrated decreased WPL with increased lubricant temperature. Thus, adjusting oil jet size as well as oil flow at required temperatures for adequate gear lubrication and cooling would need to be weighed against WPL improvements. Finally, optimizing oil drain hole geometry and location is necessary to quickly remove the lubricant from the vicinity of gear rotation and meshing to minimize the amount of oil to be recirculated into the system thereby increasing WPL. Results from these efforts would increase understanding of WPL and its potential effects on the efficiency of not only a single spur gear pair but, by extension, general effects on a gearbox.

Acknowledgements

The authors acknowledge the support of the NASA Revolutionary Vertical Lift Technology Project and also to Sigurds Lauge (HX5 Sierra LLC) for technical test support.

Bibliography

- [1] Weden, Gilbert J., and John J. Coy. "Summary of drive-train component technology in helicopters." (1984).
- [2] <http://www.hq.nasa.gov/office/aero/pdf/armd-strategic-implementation-plan.pdf>
- [3] Dudley, D.W., 1962, *Gear handbook: the design, manufacture, and application of gears*, McGraw Hill Book Company, New York, Chap. 14.
- [4] Michaelis, K., and Höhn, B-R., 1994, "Influence of Lubricants on Power Loss of Cylindrical Gears," *Tribology Transactions*, **37**(1), pp.161–167.
- [5] Dawson, P. H., 1984, "Windage loss in larger high-speed gears," *Proceedings of the Institution of Mechanical Engineers, Part A: Power and Process Engineering*, **198**(1), pp.51–59.
- [6] Handschuh, R. F., and Hurrell, M. J., 2010, "Initial Experiments of High-Speed Drive System Windage Losses," *International Conference on Gears*, Munich, Germany.
- [7] Hill, M.J., 2010, "A Computational Investigation of Gear Windage," Ph.D. thesis, The Pennsylvania State University.
- [8] Lord, A. A., 1998, "Experimental investigation of geometric and oil flow effects on gear windage and meshing losses," Ph.D. thesis, University of Wales Swansea.
- [9] Chaari, F., Romdhane, M.B., Baccar, W., Fakhfakh, T., and Haddar, M., 2012, "Windage power loss in spur gear sets," *Wseas transactions on applied and theoretical mechanics*, **7**(2), pp.159–168.
- [10] Kunz, R. F., Hill, M. J., Schmehl, K. J., McIntyre, S. M., 2012, "Computational Study of the Roles of Shrouds and Multiphase Flow in High Speed Gear Windage Loss," *AHS International 68th Annual Forum and Technology Display*, Ft. Worth, Texas.
- [11] Delgado, I., and Hurrell, M., 2017, "Experimental Investigation of Shrouding on Meshed Spur Gear Windage Power Loss," *AHS International 73rd Annual Forum and Technology Display*, Ft. Worth, Texas.
- [12] Seetharaman, S., Kahraman, A., 2010, "A windage power loss model for spur gear pairs," *Tribology Transactions*, **53**(4), pp.473–484.
- [13] Petry-Johnson, T.T., Kahraman, A., Anderson, N.E., and Chase, D.R., 2008, "An experimental investigation of spur gear efficiency," *Journal of Mechanical Design*, **130**(6), pp.062601-1 to -10.
- [14] Delgado, I, and Hurrell, M., 2017, "Baseline Experimental Results on the Effect of Oil Temperature on Shrouded Meshed Spur Gear Windage Power Loss," *Proceedings of the ASME 2017 International Design Engineering Technical Conferences & Computers and Information in Engineering Conference*, Cleveland, Ohio.
- [15] Anderol Specialty Lubricants, "Anderol Product Data Sheet – Royco 555," DoD-PRF-85734, from <<http://qclubricants.com/msds/PDS/Royco555.pdf>>.
- [16] Anderson, N. E., and Loewenthal, S. H., 1981, "Effect of geometry and operating conditions on spur gear system power loss," *Journal of Mechanical Design*, **103**(1), pp.151–159.
- [17] Windows LDP 4.8.0. Computer Program, GearLab, The Ohio State University, 2017.
- [18] Genta, G., and Delprete, C., 1994, "Some considerations on the experimental determination of moments of inertia." *Meccanica*, **29**(2), pp.125–141.

- [19] Dudley, D. W., 1991, *Dudley's Gear Handbook*. Ed. Dennis P. Townsend. Tata McGraw-Hill Education, Chap. 12.
- [20] Diab Y.Y., Ville F.F., Velez P.P., Changenet C.C., 2004, "Windage Losses in High Speed Gears—Preliminary Experimental and Theoretical Results," *Journal of Mechanical Design*, **126**(5), pp. 903–908.
- [21] Pechersky, M. J., Wittbrodt, M.J., 1989, "An analysis of fluid flow between meshing spur gear teeth." 1989 International Power Transmission and Gearing Conference, 5th, Chicago, IL.
- [22] Kilmain, C. J., Murray, R., Huffman, C., 1995, "V-22 Drive System Description and Design Technologies," *AHS International 51st Annual Forum and Technology Display*, Ft. Worth, Texas.
- [23] Weden, G. J., Coy, J. J., 1984, "Summary of Drive-Train Component Technology in Helicopters," NATO-AGARD PEP 64th Symposium on Gears and Power Transmissions for Helicopters and Turboprops, Lisbon, Portugal.