

**SMALL AND MEDIUM ENTERPRISE FINANCING AND CREDIT  
RATIONING: THE ROLE OF BANKS IN SOUTH AFRICA**

by

ASHLY TEEDZWI MUTEZO

Submitted in accordance with the requirements  
for the degree of

**DOCTOR OF COMMERCE**

in the subject

Business Management

at the

UNIVERSITY OF SOUTH AFRICA

PROMOTER: PROF JACOBUS YOUNG

JUNE 2015

## DECLARATION

I Ashley Teedzwi Mutezo, hereby certify that this thesis which is submitted to the University of South Africa, is my own work except where otherwise indicated and acknowledged by means of complete references. This thesis has not, either in whole or part, been submitted for a degree or diploma at any other university. Errors and omissions noted in this work are attributed to my own imperfection.

Signed: *A Mutezo*

Date: June 2015

## **ABSTRACT**

The potential of small and medium enterprises (SMEs) in promoting economic growth in both developed and developing countries is widely accepted and documented by both scholars and policy makers. Particularly lacking are studies on the evidence in support of the importance of credit rationing to the sustainability of SMEs in an emerging economy like South Africa's. This specific problem, especially in the developing countries, has been identified as the major bottleneck in realising socio-economic potentials of SMEs in those countries. However, one of the major ways of addressing the challenge of inadequate funding that exists within the SME sector is the use of bank credit. This study was therefore undertaken to explore the role of commercial banks in the provision of credit to the SMEs in South Africa.

This study focuses on the issue of the relationship between the banking industry and SMEs. In particular, the problem of credit rationing of, and discrimination against SMEs by commercial banks was investigated. Because credit rationing and finance gaps can stem from imperfections on either supply-side (banks), or demand-side (SMEs), or both, the intention of the study was to examine both of these variables in order to uncover the implications of their relationships.

The empirical analysis is based on survey data collected by means of a structured questionnaire which was distributed amongst banks and SME borrowers in the Gauteng Province of South Africa. Contrary to the general view that commercial banks are disinclined to provide credit to SMEs, the study found that South African banks are keen to serve the SMEs and are therefore making efforts to penetrate this potentially profitable market segment. However, several obstacles are potentially restricting the involvement of banks with SMEs in South Africa. The findings revealed that regulations such as the Financial Intelligence Centre Act (FICA) and the National Credit Act (NCA) came out strongly as major hindrances of bank financing to SMEs. Furthermore, it was shown that compliance with the NCA was ranked higher than credit history and profitability as a factor hindering the approval of SME loans.

However, by using the structural equation modelling (SEM), the results also show that there is a positive and significant influence of lending technology and collateral on the supply of credit to SMEs. Variables such as creditworthiness, collateral and e-banking were found to have a positive and significant impact on the provision of credit to SMEs by commercial banks. For both the supply- and demand-side analysis, technology came out as the most important predictor of SME access to finance. This means that banks should strive to align their lending techniques with the dynamic technological developments so as to reach as many SMEs as possible even in the geographically dispersed regions. It is anticipated that improving SME access to bank credit could be the key to the growth and sustainability of SMEs, the alleviation of poverty and unemployment; and consequently leading to the growth of the South African economy.

**Key words:** SME financing, credit rationing, access to credit, credit supply, collateral, lending technology, e-banking, credit risk management, structural equation modelling, South Africa.

## **DEDICATION**

This thesis is dedicated to:

My parents, Mrs Sylvia Machiwana and the late Mr Kingstone Machiwana.

My children, Gamuchirai, Rangano and Makomborero Mutezo.

## **ACKNOWLEDGEMENTS**

I wish to express my sincere gratitude to all people who have made this research possible. Firstly, my special thanks go to my promoter, Professor Jackie Young for his invaluable guidance and support throughout the study period. Thank you for your patience and understanding.

I am also grateful to the following people: Ms Suwisa Muchengetwa for offering statistical support; participants of the 2012 African Development Workshop held at the University of Stellenbosch Business School in Cape Town, for useful comments on the research work as it progressed. My gratitude is expressed for moral support and all the valuable discussions held with peers.

My sincere appreciation goes to the University of South Africa (UNISA), especially the Department of Finance, Risk Management and Banking and the College of Economic and Management Sciences for the moral and financial support, without which, this research would have been impossible. My acknowledgements go to all the SME owner/managers and bank managers who took time out of their busy schedules to participate in this research. Last but not least, my gratitude goes to Mr Francis Kwari for offering editorial assistance. Special acknowledgement goes to all my colleagues and friends, for their support and encouragement.

Finally, my profound sense of appreciation goes to my family: my daughter Gamuchirai Thelma and sons Rangano and Makomborero, for all their love, support and encouragement throughout the period. You were my pillar of strength and always provided laughter and joy even when days were dark. Thank you for being part of such a daunting, yet worthwhile journey, which has culminated in the achievement of this milestone.

# TABLE OF CONTENTS

Declaration.....	i
Abstract.....	ii
Dedication.....	iv
Acknowledgements.....	v
Appendices.....	xii
List of tables.....	xiii
List of figures.....	xvii
List of acronyms.....	xviii

## CHAPTER 1: INTRODUCTION AND BACKGROUND TO THE STUDY

1.1	Introduction.....	1
1.2	Background to the study.....	2
1.3	Problem statement.....	4
1.4	Objectives of the study.....	5
1.5	Research questions.....	7
1.6	Research hypotheses.....	8
1.7	Significance of the study.....	10
1.8	Scope of the study.....	11
1.9	Outline of the study.....	12

## CHAPTER 2: SMALL AND MEDIUM ENTERPRISES – AN OVERVIEW

2.1	Introduction.....	14
2.2	Definition of SMEs.....	14
2.3	Characteristics of SMEs.....	21
2.3.1	Business characteristics.....	21
2.3.2	Entrepreneur’s characteristics.....	23
2.4	Role and importance of SMEs to the economy.....	24

2.5	Challenges facing SMEs in South Africa.....	27
2.6	Constraints to accessing bank credit.....	29
2.6.1	Information asymmetries.....	31
2.6.2	High Risks of SME operations.....	32
2.7	Determinants of access to funding by SMEs in South Africa.....	33
2.8	Chapter summary.....	34

### **CHAPTER 3: SMALL AND MEDIUM ENTERPRISES FINANCING**

3.1	Introduction.....	36
3.2	The capital structure of firms.....	38
3.2.1	Financial Theories of capital structure.....	38
3.2.2	The Static Trade-Off theory.....	39
3.2.3	The agency theory.....	40
3.2.4	The pecking order theory.....	42
3.3	Determinants of capital structure of SMEs.....	44
3.4	Sources of finance for SMEs.....	50
3.5	Drivers of SME bank financing.....	57
3.6	Obstacles to SME bank financing.....	58
3.7	Credit evaluation by commercial banks.....	60
3.8	Factors determining the credit rationing behaviour of banks.....	63
3.9	Techniques used in SME bank lending.....	66
3.10	Chapter summary.....	71

### **CHAPTER 4: CREDIT RATIONING AND RISK MANAGEMENT: A CONCEPTUAL FRAMEWORK**

4.1	Introduction.....	66
4.2	Imperfect markets and information asymmetry.....	66
4.2.1	Problems created by information asymmetry.....	68
4.2.2	Solutions to problems created by information asymmetry.....	70
4.3	Credit risk management for SMEs.....	71



4.3.1	Credit rationing and SME financing.....	74
4.3.2	Risk Management Systems.....	76
4.4	Innovative Risk Management in SME financing.....	78
4.5	Chapter summary.....	81

## **CHAPTER 5: RESEARCH DESIGN AND METHODOLOGY**

5.1	Introduction.....	83
5.2	The research process.....	83
5.2.1	Research philosophy.....	84
5.2.2	Positivism and interpretivism.....	85
5.3	Research approach.....	87
5.4	Research Design and methodology.....	87
5.4.1	Research Design.....	87
5.4.2	Time dimension.....	88
5.4.3	Population, sample and sampling method.....	88
5.4.4	Data collection instrument.....	92
5.4.5	The pre-testing process.....	93
5.4.6	Data collection procedure.....	94
5.4.5	Data analysis procedures.....	95
5.4.5.1	Correlation analysis.....	96
5.4.5.2	Regression analysis.....	96
5.4.5.3	Structural equation modelling .....	98
5.5	Validity and reliability of the instrument .....	101
5.6	Methodological limitations.....	105
5.7	Ethical considerations.....	105
5.8	Chapter summary.....	107

## **CHAPTER 6: EMPIRICAL RESULTS**

6.1	Introduction.....	108
-----	-------------------	-----

6.2	Part One: Analysis of the results of the bank survey.....	108
6.2.1	Characteristics of the sample.....	109
6.2.2	Level of experience of respondents.....	109
6.2.3	Job position of the respondents.....	110
6.3	Banks involvement with SMEs.....	111
6.3.1	Use of short-term and long-term products.....	112
6.3.2	Drivers for banks' involvement with SMEs.....	113
6.4	Obstacles to SME financing.....	114
6.4.1	Credit risk management.....	120
6.4.2	Relationship lending.....	132
6.5	Validity and reliability tests for the bank survey.....	132
6.5.1	Validity tests: Confirmatory factor analysis.....	136
6.6	Reliability test: Conbach's Alpha.....	136
6.7	Correlation analysis .....	138
6.8	Regression analysis.....	153
6.8.1	Model summary (Credit supply).....	140
6.9	Structural equation modelling.....	145
6.9.1	Final model generated through structural equation modelling (SEM) .....	147
6.9.2	Maximum likelihood estimates.....	148
6.9.3	Standardised regression weights.....	148
6.9.4	Squared multiple correlations.....	149
6.9.5	Final model fit using goodness of fit indices.....	150
6.10	Summary of the results for the bank survey.....	153
 <b>PART TWO: ANALYSIS OF RESULTS FOR SME SURVEY</b>		
6.11	Introduction.....	155
6.12	Characteristics of the sample.....	155
6.12.1	Gender.....	157
6.12.2	Age of the entrepreneur.....	157
6.12.3	Educational level.....	157

6.12.4 Business ownership .....	158
6.12.5 Age of the enterprise .....	158
6.12.6 Economic sector .....	158
6.12.7 Enterprise size.....	160
6.12.8 The classification of the enterprises.....	161
6.13 Financial information.....	162
6.13.1 Bank-SME relationship.....	162
6.13.2 Duration of bank-SME relationship.....	163
6.13.3 Sources of finance.....	164
6.13.4 Access to finance.....	165
6.14 Validity and reliability test for the SME survey.....	178
6.14.1 Validity tests: Confirmatory factor analysis.....	178
6.15 Reliability test for the SME survey.....	182
6.16 Correlation analysis.....	184
6.17 Regression analysis.....	185
6.17.1 Model Summary (Access to finance) .....	185
6.17.2 Analysis of Variance (ANOVA) .....	186
6.17.3 Standardised coefficient.....	187
6.18 Structural equation modelling.....	188
6.18.1 Proposed model.....	189
6.18.2 Final model SEM.....	190
6.18.3 Parameter summary.....	190
6.18.4 Maximum likelihood estimates.....	191
6.18.5 Results of the model evaluation regarding overall fit measurement .....	192
6.19 Discussion of results.....	193
6.20 Summary of the results of the SME survey.....	195
6.21 Chapter summary .....	196

## **CHAPTER 7: SUMMARY OF FINDINGS, CONCLUSION AND RECOMMENDATIONS**

7.1	Introduction.....	197
7.2	Revisiting the research problem and objectives and hypotheses.....	200
7.3	Key findings of the research.....	200
7.3.1	Key findings from the bank analysis.....	200
7.3.2	Key findings from the SME analysis.....	204
7.4	Recommendations.....	206
7.4.1	Collateral.....	206
7.4.2	Loan products and financial services.....	206
7.4.3	Lending technology and innovative strategies.....	207
7.4.4	Information asymmetry.....	208
7.4.5	Bank-SME relationship.....	209
7.4.6	Risk Management.....	210
7.5	Contribution to study.....	211
7.6	Limitations of the study.....	212
7.7	Suggestion for further study.....	213
7.8	Final conclusion.....	214
	LIST OF REFERENCES.....	216
	APPENDIX A: BANK QUESTIONNAIRE.....	248
	APPENDIX B: SME QUESTIONNAIRE .....	256
	APPENDIX C: ITEMS DROPPED DURING FACTOR ANALYSIS.....	263
	APPENDIX D: INFORMED CONSENT LETTER FOR BANKS.....	265
	APPENDIX E: INFORMED CONSENT LETTER FOR SMEs.....	267
	APPENDIX F: RESEARCH ETHICS CLEARANCE CERTIFICATE.....	269

## LIST OF TABLES

Table 2.1	Comparative definitions of SMEs.....	15
Table 2.2	Classification of SMEs given in the National Small Business Act (102) of 1996.....	19
Table 2.3	SME thresholds in different sectors.....	19
Table 2.4	Schedule of size standards for the definition of SMEs in SA.....	21
Table 2.5	Contribution of SMEs to the South African economy.....	26
Table 2.6	Applications for finance and outcomes.....	30
Table 5.1	Various research approaches in terms of in terms of the positivist paradigm.....	86
Table 5.2	Various research approaches in terms of in terms of the interpretivism paradigm.....	86
Table 5.3	Fit indices and their acceptable levels.....	101
Table 5.4	Reliability results of dimensions.....	104
Table 6.1	Demographic profile of the frequency distribution of the sample.....	109
Table 6.2	Lending products offered to SMEs by banks.....	112
Table 6.3	Descriptive statistics for bank's involvement with SMEs.....	113
Table 6.4	Obstacles to SME financing.....	115
Table 6.5	Criteria used by banks to determine SME clients.....	117
Table 6.6	The level of awareness of cost-reducing techniques in SMEs financing.....	118
Table 6.7	The bank's response to excess demand for credit by SMEs.....	119
Table 6.8	The organisation of the credit risk management function.....	120
Table 6.9	Lending technologies used to screen SME loan applications.....	121
Table 6.10	Measures used to monitor SMEs.....	122
Table 6.11	Sectors banks prefer to extend credit to.....	123
Table 6.12	Methods used by banks to screen SMEs loan applications.....	124
Table 6.13	Factors leading to high transaction costs.....	125
Table 6.14	Objectives of bank-SME relationships.....	126

Table 6.15	What aspects of bank-SME relationship determine credit availability to SMEs.....	127
Table 6.16	Types of collateral important for approving SME loan applications...	128
Table 6.17	Factors hindering approval of SME loans.....	129
Table 6.18	Innovative strategies used in SME financing.....	130
Table 6.19	Factors that make SMEs risky enterprises for banks.....	131
Table 6.20	KMO and Bartlett's Test.....	133
Table 6.21	Principal component analysis – varimax rotation method with Kaiser normalisation.....	133
Table 6.22	Communalities.....	135
Table 6.23	Total variance explained.....	135
Table 6.24	Descriptive statistics and internal consistency.....	137
Table 6.25	Pearson correlation – Factors influencing credit supply to SMEs.....	139
Table 6.26	Model summary (Credit supply).....	140
Table 6.27	Analysis of variance (ANOVA).....	141
Table 6.28	Standardised coefficient.....	142
Table 6.29	Model Summary (innovative strategies).....	143
Table 6.30	Analysis of variance.....	143
Table 6.31	Standardised coefficient.....	144
Table 6.32	Factors that influence credit supply to SMEs by banks.....	144
Table 6.33	Definition of variables.....	146
Table 6.34	Definition of variables in the final model.....	147
Table 6.35	Regression weights: (Group number 1 - Default model).....	148
Table 6.36	Co-variances (Group number 1 - Default model).....	149
Table 6.37	Squared multiple correlations: (Group Number 1 – Default model)...	149
Table 6.38	Summary of the model evaluation regarding overall fit measurement.....	150
Table 6.39	The unstandardized regression weights and the corresponding probability values.....	151

Table 6.40	The results of the hypothesis testing.....	152
Table 6.41	Characteristics of the SMEs respondents in the sample.....	156
Table 6.42	Economic sector SME is operating in.....	159
Table 6.43	Bank where SME has a relationship with.....	163
Table 6.44	Duration of bank-firm relationship.....	163
Table 6.45	Sources of SME finance.....	164
Table 6.46	Type of loan sourced from main bank .....	167
Table 6.47	The extent to which the following types of collateral were used to source bank loans.....	168
Table 6.48	Reasons that may have contributed to failure of loan application....	169
Table 6.49	Reasons for not currently having a loan with bank.....	170
Table 6.50	Reasons for not applying for a bank loan.....	171
Table 6.51	The estimated capital structure of the enterprise.....	172
Table 6.52	Extent of use of banking products and services.....	174
Table 6.53	The extent to which SMEs use the following e-banking transactional methods.....	175
Table 6.54	Level of satisfaction of the loan application process.....	176
Table 6.55	Factors limiting SMEs from borrowing from the banks.....	177
Table 6.56	KMO and Bartlett's Test.....	178
Table 6.57	Extraction method – varimax rotation with Kaiser normalisation.....	179
Table 6.58	Communalities.....	180
Table 6.59	Total variance explained.....	181
Table 6.60	Cronbach's alpha for the Access to finance constructs.....	183
Table 6.61	Correlational analysis.....	184
Table 6.62	Model Summary (Access to finance).....	186
Table 6.63	Analysis of variance (ANOVA).....	186
Table 6.64	Standardised coefficient (access to finance).....	187
Table 6.65	Factors that influence access to bank credit by SMEs.....	188

Table 6.66	Definition of variables.....	189
Table 6.67	Regression weights: (Group number 1 – Default model).....	190
Table 6.68	Covariances (Group number 1 – Default model).....	191
Table 6.69	Squared multiple correlations - (Group number 1 – Default model)...	191
Table 6.70	Summary of the model evaluation regarding overall fit measurement.....	193
Table 6.71	Summary of the structural equation model.....	194
Table 7.1	Research hypothesis (Credit supply).....	199
Table 7.2	Research hypothesis (Access to finance).....	199
Table 7.3	Summary of conclusions from the bank questionnaire.....	203
Table 7.4	Summary of conclusions from the SME questionnaire.....	205



## LIST OF FIGURES

Figure 1.1	Research hypothesis (Banks).....	9
Figure 1.2	Research hypothesis (SMEs).....	10
Figure 3.1	The credit evaluation process.....	57
Figure 4.1	The credit rationing process.....	67
Figure 4.2	The credit risk management process.....	85
Figure 4.3	Proposed credit risk management process for SMEs.....	92
Figure 5.1	The research onion.....	108
Figure 6.1	Level of banking experience of respondents.....	110
Figure 6.2	Job positions of respondents .....	110
Figure 6.3	Banks' involvement with the SME sector.....	111
Figure 6.4	Drivers of the banks' involvement with SMEs.....	114
Figure 6.5	The Scree Plot test.....	136
Figure 6.6	Final model for the determinants of credit supply.....	146
Figure 6.7	Determinants of supply of credit .....	147
Figure 6.8	The average number of employees in the business.....	160
Figure 6.9	The classification of the enterprises .....	161
Figure 6.10	Number of loans received in the last three years.....	166
Figure 6.11	The scree plot test (SMEs).....	182
Figure 6.12	Proposed model for the determinants of access to finance by SMEs	189
Figure 6.13	Determinants of access to finance.....	192

## LIST OF ACRONYMS

ABSA	Amalgamated Banks of South Africa
AGFI	Adjusted Goodness of Fit Index
ANOVA	Analysis of Variance
BRICS	Brazil, Russia, India, China and South Africa
CFA	Confirmatory Factor Analysis
CFI	Comparative Fit Index
DED	Department of Economic Development
DST	Department of Science and Technology
DTI	Department of Trade and Industry
EFA	Explanatory Factor Analysis
EU	European Union
EUI	Economic Intelligence Unit
FNB	First National Bank
FSC	Financial Services Co-operatives
GDP	Gross Domestic Product
GEM	Global Entrepreneurship Monitor
GFI	Goodness of Fit Index
IDC	Industrial Development Corporation
IFI	Incremental Fit Index
JSE	Johannesburg Securities Exchange
KMO	Kaiser-Meyer-Olkin
MFI	Micro finance Institutions
ML	Maximum Likelihood
NCR	National Credit Regulator
NEF	National Empowerment Fund
NNFI	Non-Normed Fit Index
NSBA	National Small Business Act

PCFI	Parsimony Comparative Fit Index
PNFI	Parsimony Normed Fit Index
RMS	Root Mean Square
SAMAF	South African Micro-Finance Fund
SARB	South African Reserve Bank
SARS	South African Revenue Service
SBC	Small Business Corporation
SEDA	Small Enterprise Development Agency
SEM	Structural Equation Modelling
SME	Small and Medium Enterprise
TLI	Tucker Lewis Index
USA	United States of America
VAT	Value Added Tax
VIF	Variance Inflation Factor

## CHAPTER 1

### INTRODUCTION AND BACKGROUND

#### 1.1 INTRODUCTION

The significance of small and medium enterprises (SMEs) in economic development has made them central elements in policy making in both developed and developing countries. As such, a healthy and robust SME sector is crucial for sustainable competitive advantage and economic growth. Today, small firms in the UK employ 62 per cent of the labour force and contribute 25 per cent to gross domestic product (GDP). Of the 4.8 million businesses in the UK, over 99 percent are SMEs and they account for more than two thirds of the business turnover (Rowe, 2008). It is also interesting to note that SMEs are the major growing force behind the fastest growing economies of the emerging markets. For example, in China SMEs represent 99.3 percent of the registered enterprises and account for 55.6 per cent of the Chinese GDP, 62.2 per cent of exports and 75 percent of employment opportunities (Wu, Song and Ze, 2008). The SME sector did not exist in China up until 1980 when SMEs were officially recognised. According to Schaper, (2010) SMEs are responsible for 96% of the jobs in Brazil and comprise 98 percent of companies in that country. Therefore governments across the globe are eager to encourage and support SME development

South Africa is characterised by a low growth rate, high inflation and a high rate of unemployment of 25.5 per cent in the second quarter of 2014 (Statistics South Africa, 2014). According to Rogerson (2008), SMEs employ half of the working population and contribute about 50% to GDP. It is argued that SMEs offer an important vehicle for addressing unemployment problems as they promote growth and equity globally, and more specifically, in South Africa (Finmark Trust, 2006). The same sentiment is echoed in the New Growth Path document released in December 2010 by the Economic Development Minister, setting job creation as a priority, with a target of creating five million additional jobs in the next ten years. In his 2011 State of the Nation address, the President of South Africa Mr Jacob Zuma stated that “the small business sector is a critical component of the job creation drive”. The government thus aims to reduce unemployment from 25 percent to 15 percent, largely through the development of SMEs. Furthermore, according to the National

Development (NDP) Plan 2030, SMEs are seen as the key to future growth, transformation and job creation.

## **1.2 BACKGROUND TO THE STUDY**

While the development of SMEs is a critical focal point, the sector faces some serious challenges that inhibit the realisation of its potential. Previous studies identify adequate and accessible financing as a critical component of SME development (Fatoki, 2010). Financing is needed for business start-up, expansion and growth yet a lack of funds inhibits the growth of small businesses. The largest portion of the SME sector is unable to access loans from the commercial banks due to lack of financial knowledge, collateral and credit history. Foxcroft, Wood, Kew, Herrington, & Segal (2002) indicate that lack of collateral security in South Africa emerged as an obstacle hindering the access to bank finance for SMEs.

With inability to access the much needed capital from formal sources, SMEs are unable to grow into sustainable businesses in the long run (Mutezo, 2013). Whilst profit maximisation is the prime objective of banks, they view SME financing as risky due to default risk and lack of collateral (Voordeckers and Steijvers, 2008). The drive to minimise risks informs the decision by banks to minimise loan approval for SMEs. The question that now arises is how to strike a balance between financial intermediation towards achieving economic development, while reducing operational and credit risks that confront financial institutions at large, especially banks.

Traditionally, it is widely believed that SMEs are financially constrained. However, the one commonly cited hindrance to funding of small businesses is constrained access to finance (Fatoki and Odeyemi, 2010). Bearing in mind that banks are profit-making institutions, the overarching objective of these financial institutions is premised on profit maximisation and risk minimisation. In line with this, most SME owners are misjudged by financial institutions, essentially on the grounds of information asymmetry.

Information asymmetry is the inability of SMEs to provide commercial banks with sufficient information on their operations and potential risks and benefits therein, which is essential for banks to expediently evaluate their creditworthiness. This also enables the bank to evaluate the risk profile and susceptibility of the business/owner

to risk, as a way of determining a reasonable cost of capital. This explains why high interest rates are charged on a few successful SME applications. Conversely, high interest rates increase the operational costs of SMEs, and ultimately decrease their profitability, thereby defeating the merits of external funding.

Bearing in mind that the financial sector in South Africa is liberalised, the existence of imperfect information in the credit market may be used to explain the lending behaviour of banks to maximise profits. According to Musara and Fatoki (2012) the credit needs of borrowers, particularly SMEs, have not been met despite the increase in financial resources and regulation of the legal and institutional environment. A borrower's major complaint could be the constrained access to credit, rather than its price, implying that banks do not lend just to anyone who can afford the price of credit. Clearly banks appear to exercise some degree of credit rationing by non-price mechanisms. Credit rationing occurs when loan demand exceeds supply, and some borrowers receive nothing or less than the amount of credit applied for at prevailing market rates (Stiglitz and Weiss, 1981). Thus, the existence of imperfect information in credit markets could create risk and therefore make credit rationing a logical, profit-maximising behaviour for banks.

The constrained access to bank credit could have a negative impact on the growth of the SME sector, with serious implications on poverty and unemployment alleviation (Angelini, Di Salvo & Ferri, 1998). The SME sector credit is generally characterised by small loans, short maturity periods and high interest rates which are not favourable for long-term enterprise development (Okurut and Botlhe, 2006). Credit rationing on credit worthy firms has important adverse implications for growth of firms and the whole economy. Hence it is important to investigate this phenomenon in the South African context where the evidence to date seems scarce (Hashi and Toci, 2010)

While a series of previous studies have investigated SME funding and contributions to economic growth, there is little evidence of documented studies that critically examine the specific roles of credit rationing and risk management as determinants of the lending behaviour of commercial banks to SMEs in South Africa; hence the need for this research. The main focus of this study is on access to SME finance with specific reference to the supply side, mainly commercial banks. In this study, the

main criteria for accessing bank loans are subsumed under two main aspects, namely credit rationing and risk management principles.

### **1.3 PROBLEM STATEMENT**

According to the second quarter report of Statistics South Africa (StatsSA, 2014), the rate of unemployment in South Africa rose to 25.5%, the highest since 2008. Approximately 5.2 million persons were unemployed. It has been noted that restrictions on credit to small businesses are a global phenomenon (Baas and Schrooten, 2006). For example, in Canada, forty five percent of the SMEs are able to access commercial lines of credit (Statistics Canada, 2007). In developing countries like South Africa, most SMEs seem to still find it very difficult to access debt finance. This is supported by the findings of FinMark Trust (2006), which indicate that only two percent of new SMEs in South Africa are able to access bank loans. Access to finance is necessary for SMEs to start and grow. For most SMEs, bank lending is considered the most important overall source of external funding (Berger and Udell, 2002) yet a lot of SMEs are denied access to bank credit due to information asymmetry. Therefore, an analysis of the way in which banks operate as finance providers is necessary as they seemingly represent the main source of finance for SMEs.

According to the literature a funding gap exists for SMEs. A “funding gap” refers to deficiency in financing for good SMEs who otherwise deserve credit at the start-up stage and beyond. For example, such small firms have good business models, skilled entrepreneurs and a high growth potential but they cannot get bank credit. SMEs with a funding gap also tend to be undercapitalised and opaque resulting in most of them being unable to afford audited financial statements. The traditional lending technologies based on strong financial ratios cannot solve the funding gap problem for SMEs (Berger and Udell, 2006) especially in developing economies where the information environment is weak. However, the gap could worsen under systematic shocks such as the recent global financial crisis.

Literature on SME financing has tended to emphasize relationship lending as the primary solution to the financing gap. According to Garriga (2006), relationship lending is a special form of interaction between a bank and its borrowing firm in which banks gather private information through repeated interaction with the same

customer. Resultantly, lenders are able to produce or gather information about the borrower beyond that which is readily available. Hence close relationships are thought to reduce credit rationing for borrowers. Relationship lending is one of the technologies used by banks to solve the problem of information asymmetry.

Due to cost, data and collateral or security reasons, transactional methods of lending decision making are not best suited to new or risky SME lending decisions. Berger and Udell (2002) propose that these transactional methods may best be suited to firms with long financial histories and high levels of collateral. To these authors, relationship lending is often employed by banks throughout the world as a measure of overcoming such difficulties in lending decision making. Historically, this asseveration has been established by previous research (Baas and Schrooten, 2006). Relationship lending has been widely advocated to surmount many of the problems associated with bank lending decisions such as adverse selection, information asymmetry, monitoring and intermediation risks. Relationship lending could thus be based on the experience of a given bank with a concrete borrower and therefore on “soft” information collected overtime (Baas and Schrooten, 2006). Thus, if financial data is limited, relationship lending could be the technique of choice.

Due to the problems of accessing bank credit, a large proportion of South African SMEs rely more on self-financing in the form of personal savings, loans/donations from family and friends as well as retained earnings. The implication, therefore, is that SMEs do not always have adequate credit to meet their financial needs at different levels of growth.

#### **1.4 OBJECTIVES OF THE STUDY**

The main objective of this research is to empirically investigate the main factors which determine the credit rationing behaviour of banks towards SMEs in South Africa. This study focuses on uncovering why commercial banks are discriminatory against SMEs and what could possibly be done to enhance a better capital deepening; essentially to improve the ratio of capital that is directed to the SMEs. As suggested by literature, if SME access to finance is improved, this sector of the economy will be able to contribute more meaningfully to economic development and job creation in a country where almost a quarter of the total population is unemployed.



The main source of finance for small businesses in most developing and emerging economies is bank credit (Berger and Udell, 2002). However, there are a constantly increasing number of applications for commercial bank loans from SMEs whose readiness to pay interest rates over and above the prevailing rates is a strong indication of excess demand for credit by small businesses (Akuetteh, 2009). A number of studies have shown that access to finance is a greater obstacle for SMEs than it is for large firms, particularly in developing economies (atieno, 2009; Beck, Demirguc-Kunt, & Maksimovic, 2005; Beck, Demirguc-Kunt, Levine & Maksimovic, 2006). There is evidence that SMEs in both developing and developed countries have experienced difficulties in accessing credit from the banks (Ayyagari, 2007; Beck, Demirguc-Kunt and Martinez Peria, 2008). Consequently, the majority of small business credit applications are turned down because they are unable to satisfy the credit application requirements such as information transparency and collateral (Ayyagari, 2007; Beck et al., 2008).

Despite the increasing demand for bank credit, commercial banks are unable to supply the required credit to small firms because of high transaction costs, high default rates, lack of security and the perceived risks associated with small business lending (Binks and Ennew, 1996). In addition it is difficult for the banks to collate reliable information on SMEs and coupled with this, the high probability of default deters banks from lending to small businesses (Bbenkhele, 2007; Lucey, 2010). This study is therefore intended to determine factors that banks should consider when lending to SMEs in order to enhance the access to credit by SMEs in view of the current limited access to finance. It is anticipated that resolving the borrowing challenges faced by SMEs will result in reducing unemployment, poverty and economic growth in South Africa.

Based on the foregoing discussion, the main objective of this study is to investigate whether SME financing is now a strategic and profitable market for financial institutions in emerging markets; and if so, to devise possible interventions and guidelines towards improving SME access to bank finance in South Africa.

Following from the main objective outlined above, the secondary objectives of the study are listed below:

- to investigate the banks' involvement with SME financing;

- to determine the factors driving commercial banks' desire to become involved with the supply of credit to SMEs;
- to investigate the obstacles to SME financing by commercial banks in South Africa;
- to determine how banks manage credit risk associated with credit supply (SME financing) to SMEs;
- to determine the factors which influence the supply of bank credit to the SME sector in South Africa;
- to investigate the economic sector or industry in which SMEs operate in.
- to investigate the challenges faced by SMEs in accessing bank finance; and
- to determine the factors which influence access to bank credit by SMEs in South Africa.

In support of the drive towards achieving the above-mentioned objectives, this study will endeavour to address the following research questions.

## **1.5 RESEARCH QUESTIONS**

The study acknowledges that problems exist both on the supply and demand sides of SME financing in South Africa and therefore, focuses on both the supply- and demand-side problems. In order to achieve the stated objectives of the study, the following questions have been posed:

1. To what extent are the commercial banks involved with SME financing?
2. What are the drivers of bank financing to SMEs?
3. What are the obstacles of bank financing to SMEs?
4. How do banks manage credit risk associated with SME financing?
5. What are the main determinants of credit supply to SMEs by South African banks?
6. What is the impact of transaction costs, creditworthiness, collateral, lending technology, bank-SME relationship and risk management on credit supply to SMEs in South Africa?
7. What are the main challenges faced by SMEs in accessing bank financing in South Africa?

8. What is the impact of creditworthiness, collateral, technology, credit rationing and bank-SME relationship on SME access to bank credit in South Africa?

In the light of the findings from the main questions, it will be necessary to consider and answer two subsidiary, but significant, questions:

9. How can access to bank finance be improved in the context of South Africa's SME clients' needs?
10. What, if any, changes could be made to South African banks' SME financing policies to promote and develop SME financing?

## **1.6 RESEARCH HYPOTHESES**

This study was meant to investigate the factors that influence the supply of bank credit to SMEs in South Africa. The study focused mostly on the credit supply related characteristics which were deemed to be more relevant in explaining the credit rationing behaviours of banks towards SMEs. These factors include transaction costs, collateral, lending technology, creditworthiness, innovative strategies, bank-SME relationship and risk management. The sixth research question was translated to the following hypotheses based on the literature study.

- H1: Transaction costs significantly impact credit supply to SMEs by banks.
- H2: The availability of collateral security significantly impacts credit supply to SMEs by banks.
- H3: The cost of lending technology significantly impacts credit supply to SMEs by banks.
- H4: Creditworthiness of SMEs significantly impacts credit supply to SMEs by banks.
- H5: Bank-SME relationship significantly impacts credit supply to SMEs by banks.
- H6: Innovative strategies significantly impact credit supply to SMEs by banks.
- H7: Risk Management significantly impacts credit supply to SMEs by banks.

The research hypotheses diagram constructed using AMOS 23 path diagrams is shown in figure 1.1 below:

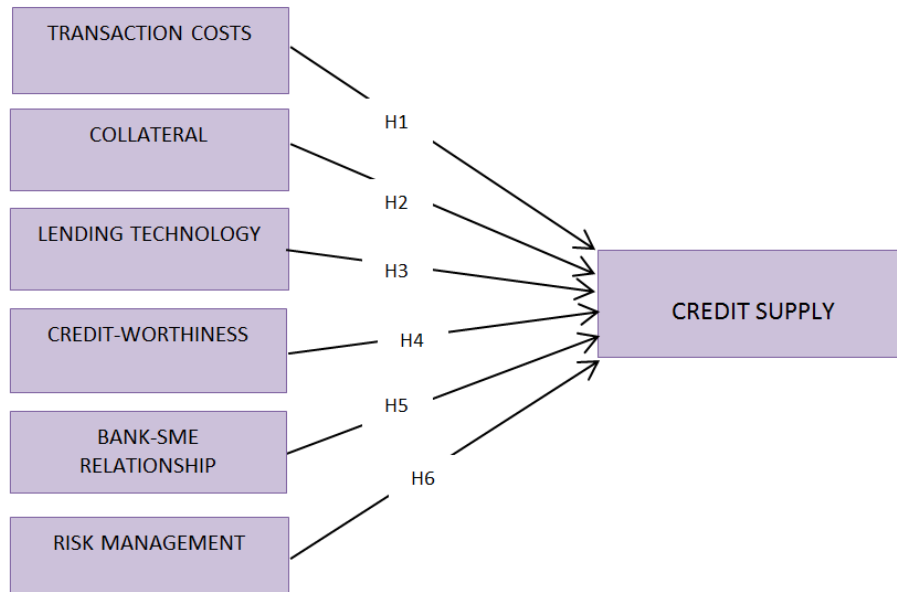

**Figure 1.1:** The research hypotheses (Banks)

Figure 1.1 above was constructed on the basis of the research hypotheses to diagrammatically show how credit supply determinants (independent variables) link up with the dependent variable (credit supply). The proposed model is used as the base to run the Structural Equation Modelling analysis presented in later chapters.

The study also sought to investigate the factors that influence SME access to finance from the demand side in order to complement the findings from the supply-side. These factors include creditworthiness, collateral security, information asymmetry, credit rationing and E-Banking. These set of variables are translated to the following hypotheses based on the literature study:

- H1: Creditworthiness significantly impacts SME access to bank finance.
- H2: Collateral security significantly impacts SME access to bank finance.
- H3: Information asymmetry significantly impacts SME access to bank finance.
- H4: Credit rationing significantly impacts SME access to bank finance.
- H5: E-Banking significantly impacts SME access to bank finance.

The diagrammatic depiction of the research hypotheses is shown in Figure 1.2, using AMOS 23:

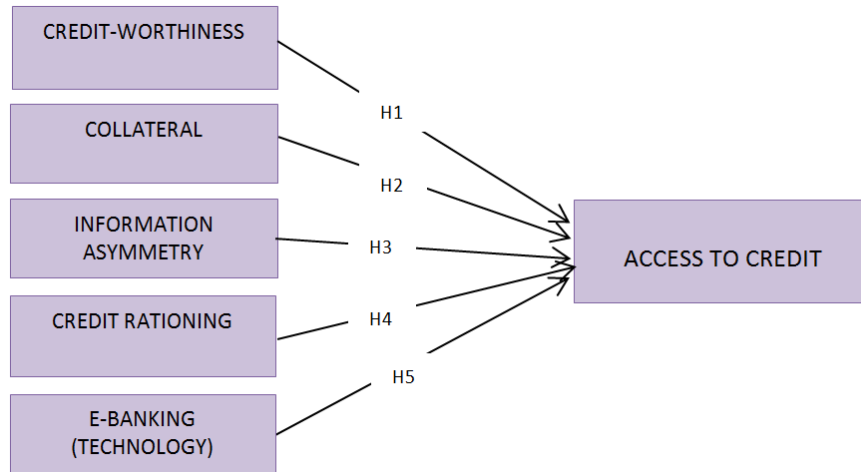

**Figure 1.2:** The research hypotheses (SMEs)

Figure 1.2 above was constructed on the basis of the research hypotheses to diagrammatically show how access to credit determinants (independent variables) link up with the dependent variable (SME access to credit). The proposed diagrammatic depiction of the hypothesis is used as the base to run the Structural Equation Modelling analysis presented in later chapters.

### 1.7 SIGNIFICANCE OF THE STUDY

The role of bank lending to SMEs continues to be a subject of intense discussion especially in the context of the impact of the recent global financial crisis. The study contributes to the debate by providing new insights into the role of banking competition and technological changes globally. Of particular interest is the impact of the technological changes on the banking industry and how this consequently affects SME financing in an emerging economy such as South Africa. rgins and the risks involved by engaging with this market segment.

This study is likely to make significant contributions in a number of areas. It has important implications for policy makers, finance providers, entrepreneurs and managers of SMEs. The findings and recommendations could assist entrepreneurs and managers of SMEs in tackling their financing problems. It is anticipated that SMEs will benefit from the study, by an improved understanding of how financial providers operate and therefore position themselves better to gain access to bank finance.

In most countries, banks are still the main source of external finance for SMEs. It is therefore important for the banking sector to develop practical and sustainable means of extending credit to SMEs. This will enable banks to be aware of the potential of the SME market and therefore develop strategies and innovations that will satisfy the current needs of SMEs in South Africa.

Interest in the role of the SME sector in the development process continues to be in the forefront of policy debates globally. Therefore, it is hoped that the findings from this study will enable policy makers and practitioners to develop or improve appropriate policies aimed at addressing the financing problem that confronts the SME sector. The development of SMEs is seen as accelerating the wider socio-economic objectives, including job creation and poverty alleviation.

Finally the study also seeks to add to the existing academic knowledge in that it will serve as a reference for subsequent research in the area.

## **1.8 SCOPE OF THE STUDY**

This study focuses on examining the factors that determine access to bank credit by SMEs in South Africa as well as the role of banks in SME financing. The study further investigates the involvement of banks with SMEs and the challenges they face when lending to SMEs.

Typically this study was delimited in terms of geographical coverage, participant financial institutions and profile of respondents. The study was limited to bank personnel involved in the SME lending units of the four leading commercial banks. The study also mainly focused on the Gauteng Province as it can be regarded as the economic hub of South Africa in general.

Participant SMEs included formally registered businesses with the Department of Trade and Industry (DTI), while survivalists and microenterprises were excluded from the study since they do not appear in official registers of businesses.

## **1.9 OUTLINE OF THE STUDY**

To present a comprehensive and coherent report, this study adopts the following structure:

Chapter one gives an introductory background and an overview to the research study. The problem statement, objectives, research questions, research hypotheses and significance of the study are dealt with, and the structure of the rest of the thesis is summarised.

Chapter two provides a theoretical framework for existing literature on SMEs in South Africa and globally vis-à-vis their economic significance as well as challenges that confront SMEs, essentially, finance-related challenges. In Chapter three, the capital structure determinants of SME financing as hypothesised by financial theories of capital structure are examined.

Chapter four provides a comprehensive literature study of existing theories and concepts regarding credit rationing and risk management in a banking environment. It further elucidates the conceptual framework of SMEs as well as the financial aspect of their operations.

Chapter five explains the position of this study in relation to the major scientific research paradigms, and discusses the methodology used to collect and analyse the data for exploring the research questions set for the study. The rationale for choosing the quantitative approach is highlighted. Data collection and pilot study procedures are explained and the target population and sampling techniques are clarified and justified. The chapter also elucidates the techniques used in the data analysis.

Chapter six deals with the analysis and interpretation of the results based on both the bank and SMEs surveys. A discussion of how the data were analysed and interpreted is presented based on the major statistical techniques used in this study namely descriptive and inferential statistics, multiple regression analysis and structural equation modelling (SEM). Research results are discussed, synthesized and corroborated with theory and other empirical studies.

Chapter seven synthesises the results from the analysis of both the bank and SME surveys in order to get a clear understanding of the challenges faced in SME financing and the factors influencing the supply of bank credit to SMEs. The chapter presents a summary of the key research findings and demonstrates the contribution made by this study to the body of knowledge. Conclusions and the limitations of the study are drawn; and recommendations for further research highlighted.



## **CHAPTER TWO**

### **SMALL AND MEDIUM ENTERPRISES – AN OVERVIEW**

#### **2.1 INTRODUCTION**

The previous chapter introduced and provided the background information against which this study is based. The aim of this chapter is to lay a theoretical foundation for the evaluation of the relevance of the small and medium enterprises (SMEs) sector to the South African economy. This is intended to uncover the challenges that confront SMEs, as a way of leveraging their potential benefits towards advancing the national economic development. This chapter reviews available literature on some of the important issues on SMEs. Firstly, the definition of SMEs is discussed and the characteristics of the SMEs and the entrepreneur are reviewed. The role and importance of the SME sector to economic development are highlighted. The constraints faced by SMEs are also discussed with specific reference to the difficulties they face in accessing bank finance to support their business development. Lastly, the determinants of access to funding by South African SMEs are discussed.

#### **2.2 DEFINITION OF SMEs**

A firm can be classified in terms of two groups of characteristics (Bolton, 1971): quantity characteristics, such as employment, assets, turnover; and quality characteristics, such as innovations and organisational structure. However, it can be noted that the latter are much more difficult to measure. Therefore, the most common criteria for differentiation between small, medium and large firms are the quantity properties, of which the size of employment and volume of annual turnover are the most frequently used. Nonetheless, a single standard definition of SME, that is uniformly acceptable does not exist (Beck, Levine and Demirguc-Kunt, 2005).

The definition of SMEs differs widely among countries, depending on their stage of economic development and prevailing social conditions (Organisation for Economic Cooperation and Development, 2007). The definition of small firms also varies in terms of size, finance, sector and ownership, which make consistence on its definition more unstable (Dabo, 2006). Some definitions refer to the number of employees as their distinctive criteria for defining SMEs; some use financial

indicators such as capital turnover while others use a combination of employee head count, invested capital, annual sales turnover and industry type (Dababneh and Tukan, 2007). There is therefore neither a global consensus nor a single and uniformly acceptable definition of what constitutes small firm categorisation (Storey, 1994).

Following from the foregoing, SMEs have been defined along a broad continuum of size and type. In terms of size, a number of parameters such as number of employees, total net assets, annual sales turnover and investment level are used across the globe to distinguish between SMEs (Kushnir, 2010). For example, the European Union (EU) defines SMEs as those firms that employ less than 250 people, with annual sales not exceeding \$67 million and/or total assets not exceeding \$56 million. Small enterprises are classified as those firms employing 10 to 49 people with annual sales not exceeding \$13 million. However, according to World Bank (2007a) the most commonly used criterion is the number of employees, due to the comparative ease of collecting such information in any country. Based on employee headcount, Table 2.1 below gives a summary of the comparative definitions of SMEs across the globe including the European Union (EU), the United States (US) and some of the emerging economies of BRICS. BRICS is acronym of an association of leading emerging economies consisting of Brazil, Russia, India, China and South Africa. With the possible exception of Russia, the BRICS members are all developing economies or newly industrialised countries, distinguished by their large, fast-growing economies, and significant influence on regional and global affairs (Schaper, 2010).

**Table 2.1:** Comparative definitions of SMEs

Definition by	Micro enterprise	Small enterprise	Medium enterprise
<b>Number of employees</b>			
US Small Business administration	1-19	20-99	100-499
European Union	1-9	10-49	50-249
Brazil	1-9	10-49	50-99
China	1-299	300	300-3000
Ghana	1-5	6-29	30-99
South Africa	1-5	20-49	50-200

Source: Compiled from literature

As reflected in Table 2.1, a small business in Ghana is an enterprise with 6 to 29 employees while, a medium-sized enterprise employs between 30 and 99 people. However the same medium enterprise would be classified as a small business in the US. Where a business is regarded as medium-sized if it employs less than 500 people while in New Zealand SMEs are defined as enterprises with 19 or fewer employees (Ministry of Economic Development, 2011). The EU and Brazil use the same limit to categorise micro and small enterprises but different cut-offs for the medium enterprise limit. Therefore, many businesses in America and Europe regarded as medium enterprises with 250 to 500 employees would be categorised as large enterprises in South Africa where firms with up to 200 employees are categorised as large. However, given China's large population and the labour-intensive characteristics of its SME sector, a small business can employ up to 3000 employees depending on the industry (Kongolo, 2010). Thus it is almost impossible to compare SMEs globally because they differ fundamentally over the threshold levels for distinction between small, medium and large firms.

According to Storey (1994) the best description of the key characteristics of a small firm favours the postulation of the Bolton Committee in its 1971 Report on Small Firms. The report formulated 'economic' and 'statistical' definitions for SMEs. On one hand, under the economic definition, a business is regarded as small if it has a relatively small market share; independently owned, operated and financed without a formalized management structure; and does not form part of a large enterprise (Nieman, 2006).

The statistical definition on the other hand, takes into account three generally accepted parameters, either separately or in combination, when defining SMEs in different countries (Nieman, 2006). These include quantifying the financial size of the small firm sector, its contribution to GDP and the employment capacity of the business. The statistical definition recognises that size is relevant to the sector, for example, in Canada; a small business is defined as one that has fewer than 100 employees (if the business is a goods-producing business) or fewer than 50 employees (if the business is service-based). However, it must be noted that the statistical definition is discordant with the economic definition of a small business, which might have up to 200 employees whilst the economic definition states that a small business may be owner managed with an informal management structure

(National Credit Regulator, 2011). The most common definitions used by regulators are based on the number of employees, sales and/or total assets. The most commonly used among the three is the employee head-count (Ardic, Mylenko and Saltane, 2011).

The definition of SMEs also varies among financial institutions. In a survey of banks in East Africa, Calice et al, (2012) found that bigger and more established banks tend to have much higher thresholds than smaller banks, and more than 56% of the banks used more than one criterion.

### **2.2.1 Definition of SMEs in South Africa**

According to Atkinson (2012), South African literature on SMEs is fairly rare. SMEs are invariably conflated with SMMEs which focuses on very small, new and emergent enterprises. Furthermore data collection on SMEs is very limited and hence it is difficult to find reliable data on SMEs. The most widely used framework for SMEs in South Africa, is the definition of the National Small Business Act (NSBA) 102 of 1996 (Abor and Quartey, 2010). South African enterprises are classified in three ways: by employee numbers, annual revenue and total assets excluding fixed property. According to the NSBA 102 of 1996, the definitions for the various business categories are given as follows:

- **Survivalist enterprise:** The income generated is less than the minimum income standard or the poverty line. This category is considered pre-entrepreneurial, and includes hawkers, vendors and subsistence farmers.
- **Micro-enterprise:** The turnover is less than the value added tax (VAT) registration limit (now R1million rand per year). These enterprises usually lack formality in terms of registration. They include, for example, *spaza* shops, minibus taxis and household industries. They employ no more than 5 people.
- **Very small enterprise:** These are enterprises employing fewer than 10 paid employees, except for the mining, electricity, manufacturing and construction sectors, in which the figure is 20 employees. These enterprises operate in the formal market and have access to technology.

- **Small enterprise:** The upper limit is 50 employees. Small enterprises are generally more established than very small enterprises and exhibit more complex business practices.
- **Medium enterprise:** The maximum number of employees is 100, or 200 for the mining, electricity, manufacturing and construction sectors. These enterprises are often characterised by the decentralisation of power to an additional management layer.

According to the criteria for identifying small businesses stipulated by the South African Department of Trade and Industry (1995), “a small business is a firm which employs less than 50, but more than 5 workers, using capital assets (excluding fixed property) valued at less than R2 million with an annual turnover of less than R6 million”. These levels of small businesses differ widely, depending on the particular sector, the growth phase of the business and access to relevant support. The quantitative criteria are presented in the Schedule to the Act as shown in Table 2.2 and classify businesses into micro, very small, small and medium, using the following guidelines in respect of different sectors of the economy:

- Total full-time paid employees
- Total annual turnover
- Total gross asset value

The NSBA, as revised by the National Small Business Amendment Act of 2003, defined the threshold per sector and subsectors as indicated in Table 2.3 below.

**Table 2.2:** Classification of SMEs given in the National Small Business Amendment Act (26) of 2003

<b>Enterprise Size</b>	<b>Number of employees</b>	<b>Annual turnover</b>	<b>Gross assets, excluding fixed property</b>
Medium	Fewer than 100 to 200, depending on industry	Less than R4 million to R50 million, depending upon industry	Less than R2 million to R18 million, depending on industry
Small	Fewer than 50	Less than R2 million to R25 million, depending on industry	Less than R2 million to R4,5 million, depending on Industry

Source: The National Small Business Amendment Act 26 of 2003.

Compared to the developed-country standards, South African thresholds for defining SMEs based on employee headcount are low. The Department of Trade and Industry (DTI, 2008:3) refined these categories per sector. Each sector has a different set of criteria. For example, a medium enterprise in Agriculture employs up to 100 people, while Manufacturing and Construction employ sectors employ up to 200 people.

**Table 2.3:** SME thresholds in different sectors

<b>Sector</b>	<b>Class</b>	<b>Employee (maximum limit)</b>	<b>Turnover in South Africa (million rand)</b>	<b>Total net asset (million rand)</b>
Agriculture	Medium	100	5	5
	Small	50	3	3
Manufacturing	Medium	200	51	19
	Small	50	13	5
Construction	Medium	200	26	5
	Small	50	6	1
Catering, accommodation & other trade	Medium	200	13	3
	Small	50	6	1

Source: DTI, 2008:3)

From Table 2.3 it can be deduced that different sectors have different dynamics in terms of labour requirements and investment thresholds. Furthermore, different types of thresholds (labour, turnover and total assets) are essential due to the divergent requirements in different sectors. Many businesses in the US and Europe regarded as medium enterprises with 250 to 500 employees would be categorised as large enterprises in South Africa where firms with more than 200 employees are defined as large.

Additionally, within a country, there may be different criteria for defining SMEs based on the purpose of categorisation. This is particularly true with respect to the South African Revenue Services (SARS). According to the SARS (2007) website, "SARS does not have one single description for a small business; instead there are several definitions utilised for different purposes, details of which are given below:

- For amnesty purposes, a small business is any business with a turnover of up to R10 million;
- For Income Tax purposes (section 12E), a Small Business Corporation (SBC) is defined as a business having a turnover of less than R14 million, in addition to other qualifying criteria; and
- For Capital Gains Tax, a Small and Medium Enterprise (SME) is described as a business having total net assets of under R5 million.

From the above discussion, it is clear that there is no universal definition of what constitutes a SME. It can be deduced that SME classification criteria vary among various countries. While SMEs operate in almost all industries, they differ greatly in their nature and importance from industry to industry and from country to country.

This study focuses primarily on SMEs that are formally registered with the DTI having 10- 200 employees, a bank account and access to capital markets or other suppliers of finance. Informal small businesses are thus excluded from this research. The study therefore adopts the quantitative definition of SMEs in South Africa as proposed by the National Small Business Amendment Act (26) of 2003. This definition is depicted in Table 2.4.

**Table 2.4:** Schedule of size standards for the definition of SMEs in South Africa

Type of firm	Employees	Turnover	Balance sheet
Small	10- 50	Maximum R13m	Maximum R5m
Medium	51- 200	Maximum R51m	Maximum R19m

Source: Government Gazette of the Republic of South Africa (2003).

From the discussion above, it can be concluded that there is no unanimity on the definition of SMEs as firms differ in their levels of employment, turnover and capitalisation. Therefore, definitions based on size, when applied to one sector could lead to all enterprises being classified as small, whereas the same size definition applied to a different sector would result in all enterprises being defined as large (NCR 2012). The lack of a single definition of SME makes comparison between bank lending practices somewhat inconsistent (Calice, Chando and Sekioua, 2012:9).

Despite the inconsistency in the comparative definitions of SMEs, the enterprises have some common characteristics. Firstly, ownership and management are held by one individual or family resulting in subjective decision-making. Secondly, SMEs require small capital base in general, regardless of the industry and the country where they are based. However, SMEs experience difficulties in attracting external funds for expansion; hence they rely heavily on finance from friends and relatives. Furthermore, there is no distinction between business and personal funds thereby resulting in inefficiency and non-performance of many SMEs. The following section addresses the characteristic features of SME which influence their access to finance.

## **2.3 CHARACTERISTICS OF SMEs**

SME characteristics affect their financial decisions and behaviour and ultimately the firm's performance and growth. Several characteristics peculiarly related to the SME sector influence the financial behaviour of firms

### **2.3.1 Business characteristics**

These include firm size and age, ownership type and legal form, geographical location, industry, sector and asset structure (indicates ability to pay). Globally it has



been established that SMEs have less access to finance than large firms and South African SMEs are no exception (Fatoki, 2012).

A firm's size may be measured by its assets, capital employed in the business, its revenue or profits or by the amount of human or physical capital it employees. Empirical studies have indicated that SMEs are financially more constrained than large firms. For example, Musara and Fatoki (2012) have indicated that restrictions on credit are greater when a firm is small. For instance, SMEs are characterised by information opacity such as inability to provide audited financial statements (Binks and Ennew, 1996). In addition to that, there is high risk involved because SMEs have high failure rate compared to large companies. The screening and monitoring of small firms may be proportionately more costly to the lender as fixed lending costs related to loan approvals make costs per dollar lent relatively higher for smaller firms (Hashi and Toci, 2010).

The age of the business can also play a significant role on a firm's ability to acquire debt. According to Dollinger (1995) the age of the business determines the sources of capital for any business. Newly established and young businesses, in most instances, lack internally generated capital and are more likely to require external sources of capital to fund their businesses. On the other hand, older businesses tend to make use of retained earnings and are thus less likely to depend on external sources of capital to fund their business operations (Hall, Hutchinson & Michaelas, 2004). Size and age of SMEs influence their access to finance as lenders and investors prefer firms that have accumulated sufficient assets that would be of collateral value (Dabo, 2006). This assertion is confirmed by Hashi and Toci, (2010) who argue that banks prefer to offer loans based on tangible assets in an effort to mitigate problems associated with increased risk ensuing from opaque information. Some of the problems revolve around adverse selection and moral hazards.

It is also argued that the form of ownership influences the sources of finance available to a firm and the degree of difficulty encountered in accessing such financing (Bhaird and Lucey, 2006). For example, previous research has established that listed firms and foreign-owned firms face lesser financial constraints (Beck et al, 2006; Calice et al., 2012). Furthermore, the legal form of the business also determines its financing decisions. Sole proprietors and partnerships are more likely

to make use of internally generated sources of capital (Storey, 1994) while companies and close corporations are more likely to make use of external funding since they exist as legal entities (Coleman and Cohn, 2000). Incorporated firms are more likely to have easy access to external finance in comparison to unincorporated firms, considering the difficulty often experienced in ascertaining the owner's personal funds from those of the business.

It can also be argued that spatial variation exists in both the cost and availability of finance for SMEs. Such spatial variation may arise due to the following:

- Absence of financial institutions in rural areas
- Bank branch managers in rural areas may have limited authority and therefore processing and approval of loan applications is delayed since it is done in the corporate head office. Rejections of loan applications can be high because the head office does not have personal knowledge of customers and projects based in distant locations

Another characteristic that influences SME access to external finance is the industry or sector the firm belongs to. Previous research has established that most SME founders set up businesses in the industry or sector in which they have prior experience. The advantages arising from such a position include lower levels of risk and better business contacts, which render it more attractive for that individual, even when the firm's profitability levels and prospects are relatively poor. In a study carried out in Mozambique, Byiers (2010) found that the economic sector was an important determinant of access to credit for small firms. The results of their study concluded that metal-mechanic and wood-furniture had significantly lower access to credit than the food processing sector. Therefore, investigating the impact of the firm's economic sector or industry on the ease or otherwise with which it can access finance is also a subject of enquiry of this study.

### **2.3.2 Entrepreneur's characteristics**

Empirical studies have repeatedly investigated entrepreneur characteristics that significantly influence the successful access to external finance (Storey, 1994). These include the business owner's age, educational attainment, management skills, training, previous sector experience and organisation size. The entrepreneur's

financing decisions may be influenced by the strong desire to maintain business ownership and independence. To achieve this objective, entrepreneurs prefer to use internal sources of capital (Abdulsaleh and Worthington, 2013). Therefore, to retain control of their businesses, entrepreneurs may choose to reduce the use of external finance. According to Barton (1989) business ownership and control are important factors that influence the capital structure and financial decisions of SMEs. Owners might perceive that any external providers of funds can interfere in the management of their business (Padachi, Howorth and Narasimhan, 2012). Furthermore, the attitude and objectives of the entrepreneur can exert important influences on the firm's ability to secure external finance, such as unwillingness to provide personal assets as collateral (Doba, 2006).

Human and social capital issues also play an important role in the establishment and development of SMEs. Therefore, the level of education and work experience provides the business with adequate human and social capital. According to Coleman and Cohn (2000), entrepreneurs with higher levels of formal education and business skills are more likely to source external finance. Storey (1994) argues that education provides a basis for intellectual development which the entrepreneur requires in order to be in business successfully and that a higher level of education provides the individual with greater confidence in dealing with customers and bankers. Similarly, the age of the business owner is more likely to influence the consideration of the business for external finance by lenders and investors (Romano, Tanewski & Smyrnios, 2001). Older business owners have a preference for internal funding sources due to the low risk involved. It is therefore important to understand the characteristics of SMEs as these influence their access to finance.

## **2.4 ROLE AND IMPORTANCE OF SMEs TO THE ECONOMY**

There is a general consensus that SMEs contribute positively to both economic and social development of developed and developing countries (Beck and Demirguc-Kunt, 2006; Pang, 2008). Economically, SMEs are recognised as engines through which growth objectives of developing countries can be achieved. As such, SMEs play a significant role in generating employment and income for both rural and urban population, and have a tendency to engage more labour intensive technology than large firms (Newman, 2010). In support of this statement, Ayyagari, Beck and

Demirguc-Kunt (2007:417), using country level data, estimate that on average SMEs account for close to 60% of employment in the manufacturing sector of many countries. In South Africa SMEs contribute approximately 61% towards employment (Abor and Quartey, 2010).

The significance of SMEs to economic growth has made them focal points in policy making in both developed and developing economies (Eikebrokk and Olsen, 2007; Maredza and Ikhide, 2013). There is evidence that SMEs are the backbone of the nation's economy particularly in developing and emerging countries (Beck et al, 2006). For example, in India and China, SMEs dominate the industrial and commercial infrastructure (Ebrahim et al, 2011). Small businesses constitute the bulk of the industrial base and also contribute significantly to exports as well as GDP. In many developing and emerging markets, the SME sector is regarded as one of the principal driving forces for economic growth and job creation (Abor and Biekpe, 2007). This holds true particularly for many countries in Africa where SMEs represent over 90% of businesses, contribute over 50% of GDP, and account for 63% of employment in low income countries (United Nations Economic Commission for Africa, 2005).

SMEs are therefore valued for their potential to grow into larger, more productive units, their ability to invest in and adopt new technologies, and adapt to new economic circumstances (Berry et al. 2002; Finlayson, 2003). SMEs also have advantages over large established firms since they are able to adapt more easily to market conditions because of their flexible nature (Abor and Quartey, 2010). They are typically more flexible due to their flat hierarchical structures and are therefore able to respond faster to changes in the external economic environment. Hence, the turnaround time for new product development tends to be shorter for SMEs than for larger firms. Furthermore, SMEs are more labour intensive than larger firms and therefore have lower capital costs associated with job creation (Musara and Fatoki, 2012). Small businesses tend to use less capital per worker and have the capacity to use capital more productively when compared to larger firms. Where they are located in the urban areas, SMEs activate untapped resources and skills, contributing to a more equitable distribution of income, place a positive role in sectoral balance and regional development and hence help strengthen political stability in the economy (Dabo, 2006).

### 2.4.1 SMEs contribution to the South African economy

In South Africa, SMEs contribute to the country's national product through the provision of goods and services to both consumers and suppliers. According to the DTI, (2008) South Africa's SMEs account for 99% of formal business entities, contributing between 52% and 57% of GDP and providing about 62% of employment (see Table 2.5). However, Berry et al (2002) noted that discussing SME contribution to GDP is problematic, since the GDP typically records only formal activities, while most SMEs are active in the informal sector.

**Table 2.5:** Contribution of SMEs to the South African economy

<b>Enterprise size</b>	<b>Percentage of registered enterprises</b>	<b>Percentage of employment</b>	<b>Percentage of gross domestic product</b>
SMEs	99.25%	66.6%	57.%
Large enterprises	0.75%	33.4%	43%

Source: DTI, 2008:43

The role of SMEs is also vital in achieving wider socio-economic goals, including poverty alleviation (Cook and Nixon, 2000). The authors allude to the fact that SMEs promote the equitable distribution of income. This in turn reduces economic disparities between rural and urban areas resulting in improved standards of living of the general population.

SMEs are also crucial in creating entrepreneurial skills and promoting innovation and sustainability (Kongolo, 2010). SMEs are important in applying new technology to better satisfy consumer demands. According to Falkena et al, (2000) information technology and the knowledge economy have made it possible for SMEs not only to create jobs, but also to generate high per capita value-added. SMEs are therefore valued for their potential to grow into larger and more productive units, ability to invest in and adopt new technologies, and their ability to adapt to new economic circumstances.

In many developed and developing countries, SMEs help buffer the shocks that come with the boom and bust of economic cycles such as the 2008/2009 world financial crisis. SMEs also serve as the key engine behind equalising income

disparities among workers (Ebrahim, Ahmed & Taha, 2010). SMEs are therefore perceived as the most important vehicle to create jobs, reduce poverty; enhance social upliftment and achieve sustainable economic growth (Musara and Fatoki, 2012).

Despite the numerous contributions of SMEs to economic development in both developed and developing economies, small businesses in many countries face a myriad of challenges. These challenges are addressed in the following section:

## **2.5 CHALLENGES FACING SMEs IN SOUTH AFRICA**

Despite the identified positive contributions of SMEs to national economies, South Africa has one of the world's highest SME failure rates (Herrington, Kew & Kew, 2009). Furthermore, Fatoki & Odeyemi, (2010) observed that about 75% of the SMEs in South Africa fail within the first two years of operation due to a number of challenges that impede their survival. Key among these include inadequately educated workforce, crime and corruption, inefficient legal systems, restrictive labour regulations, lack of managerial and entrepreneurial skills, an inefficient government bureaucracy, constrained access to financing, and inadequate supply of infrastructure (Herrington et al, 2009).

According to Fatoki (2012), there is evidence that regulatory constraints resulting from government bureaucracy place a proportionally high burden on SMEs, especially those in developing economies such as South Africa. As such, SMEs often find it difficult to receive regulatory approval to conduct business activities. Regulatory barriers prevent SMEs from operating in sectors of the economy in which local governments have vested interest in protecting state-owned enterprises (Newman, 2010). For example, the labour market in South Africa is highly regulated with a high level of market rigidity. As a result, it is difficult and expensive for SMEs to hire skilled labour (Mahadea, 2008). Consequently SMEs experience problems such as the inability to attract and retain suitable staff, loss of key employees, low productivity and inadequate training and development of employees (Brink, Cant and Ligthelm, 2003).

Furthermore, weak judicial and legal frameworks and lack of property rights increase risks and discourage investment. As a result, absence of an effective legal system to enforce credit laws impedes the development of a deeper SME credit market (Malhotra, Chen, Criscuolo, Fan, Hamel & Savchenko, 2006). The World Bank (2003) portrays a relatively inefficient legal system in South Africa compared to the emerging BRIC countries due to a shortage of judges and magistrates, backlog of cases and lower creditor protection in practice. The lack of protection for property rights limits SME access to foreign technologies (Malhotra, et al. 2006)

In addition, many SMEs lack professional managerial expertise. This statement is supported by Radipere and van Scheers (2005), when they state that the lack of skills impacts negatively on the ability of SMEs to manage their human resources efficiently, and is a major factor that influences enterprise performance. The high rate of business failure in South Africa can be attributed to a lack of managerial capacity which is a result of a lack of adequate training and education (Radipere and van Scheers, 2005).

Other challenges faced by SMEs in South Africa include problems such as the HIV/AIDS pandemic, high crime rate and poor infrastructure, which have a strong negative economic impact. On one hand, a high incidence of HIV/AIDS (18% of adults) has an enormous effect on the health of South Africa's workforce and implications on how individuals live and work with the disease (Ray, 2010). On the other hand, SME development in South Africa is hampered by crime and corruption, which is widely believed to restrain investment (NCR, 2011). The crime includes robbery, hijackings, break-ins and vandalism. The South African Police Service Crime Statistics (2013) indicates an increase in business crime between 2009 and 2013. Most of the reported cases are robberies on small business premises. SMEs are therefore not aggressively pursuing avenues to grow their market share and stay ahead of competitors. Instead, they are focusing on operational matters relating to security because of the high crime rate (Fatoki and Garwe, 2010).

According to Von Broembsen, Wood and Herrington (2008), the lack of infrastructure and the impact of macroeconomic variables are among the main challenges faced by SMEs in South Africa. Poor infrastructure such as bad roads, inadequate water supply and erratic power supply hamper SME growth in developing countries

including South Africa (Ejembi and Ogiji, 2007). As such, limited access to the Internet, transport and electricity increase the cost of bank operations. Economic variables and markets can affect the profit and effective operations of the business. These factors include fiscal and monetary policies of the government, interest rates, inflation rates and foreign exchange policies. South Africa's economy is characterised by high interest rates, high inflation (>6%), declining exchange rates and low consumption (Marcus, 2012). Economic variables therefore influence the demand for goods and services and hence the survival and growth of SMEs (Ehlers and Lazenby, 2007). Previously insulated from international competition, many South African SMEs are now faced with greater external competition and the need to expand market share. Limited international marketing experience, poor quality control and product standardisation and little access to international partners, impede expansion into international markets (Kayanula and Quartey; 2000).

## **2.6 CONSTRAINTS TO ACCESSING BANK CREDIT**

Although there could be a range of reasons why SMEs fail, constrained access to finance is ranked as one of the top obstacles to SME survival and growth (Parker, Riopelle and Steel, 1995; Peria, 2008; Newman, 2010). Fatoki and Garwe (2010) further argue that lack of financial support is the second most reported contributor to low new firm creation and high failure rate, after education and training in South Africa. SMEs have thus encountered many difficulties in accessing finance from lending institutions in support of their working capital and fixed capital investments (Blumberg and Latterie, 2008). Foxcroft et al. (2002) find that about 75% of applications for bank credit by new SMEs in South Africa are rejected. The authors reveal that large numbers of entrepreneurs fail to gain access to bank finance due to information inadequacy and lack of collateral. The results of their study are given in Table 2.6:



**Table 2.6:** Applications for finance and outcomes

	<b>Entrepreneurs applying for finance (%)</b>	<b>Applicants who were successful (%)</b>	<b>Applicants who accepted the offer</b>	<b>Applicants who received finance (%)</b>
Bank loan	84.4	23.0	85.2	18.0
Bank overdraft	8.2	62.5	76.7	9.0
Bank credit card	2.3	83.3	60.0	1.2
Micro lenders	3.1	0.0	-	0.0
Stokvel	1.2	33.3	100.0	0.4
Mortgage	0.8	100.0	100.0	0.8
Venture capital	0.4	0	-	0.0
Average	-	33.2	82.4	27.3

Source: Foxcroft et al. (2002)

From the Table 2.6 it is apparent that bank loans are the most preferred sources of external finance (84.4%) but only 23% of the applications were successful. According to Angela Motsa and Associates (2004) several problems to accessing bank finance in South Africa have been identified and these include:

- Lack of collateral security
- Failure to make a remarkable own contribution
- Blacklisting
- Failure to provide attractive financial records and/business plans
- High risk of SMEs

According to Malhotra et al, (2006) SMEs are usually more credit constrained than other sectors of the economy due to the following: information asymmetries, lack of know-how on the part of banks and high risks inherent in lending to SMEs. These factors are addressed in the following section.

### **2.6.1 Information asymmetries**

Access to finance is limited by the presence of information asymmetry problems between lender and borrower, leading to market failure in the provision of finance to SMEs (Levitsky and Prasad, 1987). Due to market failure, excess demand for bank finance over supply arises resulting in an imperfect market situation (Stiglitz and Weiss, 1981). This scenario is known as credit rationing and refers to the situation where lenders limit the supply of additional credit to borrowers who demand funds even if the latter are willing to pay higher interest rates. It is thus an example of market imperfection, as the price mechanism fails to bring about equilibrium in the market (Arroyo, 2007). The interest rate that the borrower is willing to pay does not represent a reliable measure of risk as the presence of information asymmetry impedes the bankers from knowing the profit distribution of the project that indeed, is known by the borrower (Arroyo, 2007). It is therefore difficult or costly for banks to obtain information on the creditworthiness of potential SME clients. As a result, lenders charge SMEs high interest rates or abstain from lending to them altogether.

Since the funding institutions do not have full information about the SMEs, they cannot make informed decisions on their loan applications (Hutchinson and Xavier, 2006; Nkuah, Wang & Gaeten, 2013). The SMEs usually hoard away the undesirable information from the lender, when they are applying for the loan. There is therefore decision risk on the part of the lender, and to avoid or reduce the perceived risk, the lender rejects the loan application or rations the credit value. This scenario is referred to as adverse selection (De Meza & Webb, 1987; Zambaldi, Aranha, Lopes & Politi, 2009). After the loan is approved, there is a possibility that the loan beneficiary may utilise the funds in activities not expected or known to the lender, leading to failure to repay the loan as per loan contract. This misappropriation of the loan is referred to as a moral hazard, which has been documented as being the main reason why the lenders ration the loan values (Baas and Schrooten, 2006).

Under conditions of adverse selection and moral hazard, there is a tendency for high-risk individuals to willingly pay higher rates for credit and the risk that a party to a contract can subsequently change its behaviour to the detriment of the other party (Hall, 2002). Adverse selection can therefore change with lender beliefs and even with the cost of applying for funding. According to Bellier et al (2012), adverse

selection can lead to credit rationing. Reducing this information asymmetry has been suggested to be one of the probable methods to reduce the impasse of credit rationing (DeGennaro, 2005).

With information asymmetry, it is extremely difficult for lenders to accurately distinguish between creditworthy and non-creditworthy borrowers. SMEs are thus more likely to be credit rationed because they are perceived as particularly riskier than large firms. Banks therefore prefer to reduce the credit volume, ration or increase collateral requirements to deter demand for credit (Berger and Udell, 1990; Coco, 2000). In some instances, banks restrict the provision of credit to specific projects, business size, entrepreneurial experience, business track record, and provision of collateral and geographical location of applicants due to information asymmetry (Akuetteh, 2009).

### **2.6.2 High risks of SME operations**

The operations of SMEs with information asymmetries are subject to risks such as vulnerability of turnover and managerial weakness (Malhotra et al., 2006). Such SMEs are more vulnerable to market changes and often have inadequate management capabilities due to their small size. According to Fatoki (2012) the high failure rate of South Africa's SMEs, validates the inherently high risk associated with them. Extreme volatility of SME activities (with a large number of them starting up while many others are closing down), lack of markets and shortages of working capital contribute to the high failure rate among SMEs. This stems from the fact that SMEs have limited access to capital markets, locally and internationally, in part because of the perception of higher risk, informational barriers, and the higher costs of intermediation for smaller firms. As a result, SMEs obtain long-term finance in the form of debt and equity.

Malhotra et al, (2006) argue that SMEs' access to finance may actually be constrained by weaknesses in firm management and the records their management present when applying for credit. In most cases, SMEs largely rescind to submit the required audited financial statements and comprehensive business plans that banks need in order to process their loan applications. Thus banks often complain that loan applications from SMEs are not meeting their standards.

One important intervention to reduce the risk of information asymmetry is the use of collateral as a signaling and bonding mechanism and/or the cultivation of a sound working relationship between lender and borrower (Binks and Ennew, 1996). However, SMEs are still disadvantaged since they have little or no accumulated assets to use as collateral on one hand, and have poor reputation which takes time to acquire on the other. Information asymmetry is however minimized to some extent through the establishment of a fiduciary relationship between the bank and its clients. Consequently many SMEs are rationed out of the loan market mainly due to information opaqueness. Hence established large firms are more likely to gain more access to bank credit than small firms.

## **2.7 DETERMINANTS OF ACCESS TO FUNDING BY SMEs IN SOUTH AFRICA**

According to the Gordon Institute of Business Science (GIBBS, n.d), there is a general perception amongst entrepreneurs that access to capital is a major inhibitor to SME growth. Various problems and obstacles that are associated with accessing bank capital in South Africa include the following:

- **Discrepancies in matching between funding mandates and entrepreneur's eligibility**

The fit between bank's criteria and SMEs is often problematic. Entrepreneurs tend to submit applications that are inconsistent with the funder's directive. In South Africa, SMEs tend to seek funding without the required business size and sophistication as collateral to back up their applications (GIBBS, n.d).

- **Oversupply of entrepreneurs in highly saturated markets and industries**

Banks are often approached by small businesses operating in highly saturated markets with no competitive advantage. In most cases, lack of innovativeness makes it difficult for SMEs to present unique business models and opportunities to the funding institutions.

- **Lack of awareness and preparedness amongst entrepreneurs**

Lack of access to finance is aggravated by the general lack of awareness about the procedures and the courses of action involved in gaining equity funding, leaving entrepreneurs underprepared and under-researched. The

application process tends to be bureaucratic and heavily laden with protocol and red tape as banks endeavor to gain confidence in small business entrepreneurs (GIBBS, n.d).

Banks are therefore reluctant to lend to SMEs due to information asymmetry which makes it very difficult for them to verify creditworthiness, adverse selection and moral hazard problems (Berger and Udell, 2002). Furthermore, SMES generally lack long credit history or successful credit record that banks can rely on in making investment decisions. This problem is further compounded by the fact that banks perceive lending to SMEs as a risky business (Hashi and Toci, 2010). Potential costs and time involved in collecting information on credit worthiness on SMEs discourages banks from lending to them (Newman, 2010).

As noted in the literature and to emphasize, access to bank financing by SMEs has continually been a challenge facing policy makers and banks as the major providers of credit. Various reasons are fronted for these challenges which include, from the bank side, high lending rates and general lack of expertise in SME financing. From the SME perspective, it was noted that lack of collateral and inadequate financial information are some of the major constraints (Musara and Fatoki, 2012). From the above analysis, it is evident that banks may avoid lending to SMEs (especially start-ups and very young firms) that typically lack collateral or firms whose activities offer possibilities of high returns but substantial risk of loss.

## **2.8 CHAPTER SUMMARY**

In this chapter the SME definition was examined and it was noted that there is neither consensus, nor a single and uniformly acceptable global definition of SMEs. The most commonly used criterion is the number of employees. The study therefore adopts the quantitative definition of SMEs in South Africa as proposed by the National Small Business Amendment Act (26) of 2003.

The chapter further goes on to discuss characteristics of SMEs and their importance to national economies. The SME sector is regarded as a viable sector that has substantial economic growth potential in both developed and developing economies. SMEs thus contribute to economic growth, employment creation, regional and local

development due to their flexibility and innovation capacity. They act as seedbed for the development of entrepreneurial skills, curb the monopoly of large companies and offer complementary services to larger firms. In rural areas, small firms activate untapped resources and skills thereby contributing to equitable distribution of income and eradication of poverty.

Despite their vital significance to economic growth, SMEs face a myriad of challenges. However, difficulty in accessing bank finance is one of the top challenges experienced by small businesses in both developed and developing countries due to information asymmetries, lack of collateral, perceived high risk and lack of managerial and entrepreneurial skills.

One important intervention to reduce the risk of information asymmetry is the use of collateral and the nurturing of banking relationships between the banks and SMEs. From the banking perspective SMEs' access to finance is hindered by the mismatch between funding mandates and the entrepreneur's eligibility; highly competitive markets and the general lack of awareness of the loan application procedures and processes. The next chapter reviews the capital structure of SMEs and sources of financing.

## **CHAPTER 3**

### **SMALL AND MEDIUM ENTERPRISE FINANCING**

#### **3.1 INTRODUCTION**

The previous chapter examined the definition and contributions of SMEs globally and to the South African economy in particular. It was found that SME definitions vary among different countries as well as in South Africa depending on the economic sector of interest. The issues of credit availability to SMEs have generated considerable interest among scholars and policy makers. Literature on small business financing has shown that in most developing and emerging economies, SMEs encounter challenges when accessing external finance in an effort to support growth and sustainable development (Abor and Biepke, 2007). The chapter also deals with the challenges faced by South African SMEs and lack of access to credit was found to be one of the prime factors contributing to the high failure rate of SMEs in South Africa. However, researchers have observed that the SME sector has a major role to play in the South African economy just as in other economies, essentially in terms of employment creation and income generation. As stated in chapter one, SMEs account for approximately 60% of all employment and 57% of the GDP in South Africa (DTI, 2008). For that reason, SMEs are thus seen as a vehicle through which the lowest income earners can gain access to economic opportunities at a time when the distribution of income and wealth is amongst the most unequal in the world.

This chapter reviews the issues relating to the capital structure of small businesses, the sources of finance, the factors affecting availability and accessibility of bank credit as well as the challenges faced by banks in making SME lending decisions. Several financial theories have been developed in an effort to explain the capital structure adopted by SMEs. These theories include the static trade-off theory, the agency theory and the pecking order theory. Numerous researches have been done on the capital structure of large publicly listed companies which are accessible to national and international capital markets (Li, Yue & Zhao, 2009). Such firms are legally required to disclose financial and accounting information to the general public; and are therefore not subject to the institutional constraints imposed by the domestic

financial systems (Li et al., 2009). Contrary to this, the extent to which capital structure theories are applicable to SMEs in the developing economies has received less attention due to limited availability of SME information in these economies.

It needs to be pointed out that the financial requirements of SMEs vary in size, frequency and maturity depending on the growth stage of the small business (Newman, 2010). In addition, the sources of finance available to SMEs change with time (Berger and Udell, 1998). SMEs can initially be financed from internal sources such as personal savings and/or external “informal” sources of finance such as “soft loans” from family and friends. As the business grows, formal external sources are sought such as bank loans and overdrafts, venture capital, money markets, and lastly private equity firms. According to the FinMark Trust (2006) only 2% of SMEs in South Africa are able to access bank loans. Without sufficient long-term finance, small firms are unable to expand their businesses and it is even more challenging to introduce productivity-enhancing technology. These challenges could adversely affect the competitiveness of the sector and the economy as a whole, as the SMEs’ functionality is hindered and their innovativeness, hampered.

Firstly an overview of the theory of capital structure with regard to SME financing decisions is presented. Factors which determine the capital structure of SME are also discussed. Secondly, the literature which covers sources and types of funding available to SMEs is discussed. It is important to understand the financing preference of SMEs as the choice of finance at different stages of business growth affects their performance and contribution to the economy. Thirdly, the review explores the drivers of the banks’ involvement with SMEs and the obstacles they encounter in their bid to fund small businesses. Fourthly, the review examines the process of credit evaluations by banks and the factors that determine their credit rationing behavior towards SMEs. Fifthly, the lending techniques used by banks in SME funding are discussed and finally, implications of the reviewed literature to the present study are presented.

### **3.2 THE CAPITAL STRUCTURE OF FIRMS**

Capital structure has been defined as the mix of debt and equity that a firm uses to finance its operations (Myers, 1984). According to Hutchinson and Xavier (2006), a capital structure decision is one of the most complex decisions facing a firm. The



cost of capital of a firm can thus be lowered through the implementation of effective capital structure decisions and hence increase shareholder's wealth. According to Gitman (2009), the corporate finance theory of profit maximisation stipulates that the value of the firm is maximised when its cost of capital is minimised. However, this is a difficult measure to determine the optimal combination of debt and equity financing of a company. Thus, the optimal capital structure is the combination of debt and equity at which the weighted average cost of capital of a firm is minimised and shareholder's wealth is maximised. The weighted average cost of capital is the average cost of debt and equity funding weighted by the proportion of the firm's capital structure that the two components constitute (Gitman, 2009). The major competing theories of capital structure are discussed in the next section.

### **3.2.1 Financial Theories of capital structure**

Contemporary capital structure theory is based on the influential work of Modigliani and Miller (1958), who under the assumptions of perfect markets, proposed a model that suggests that any changes in a firm's capital structure has no impact on the value of the firm. The theory is based on the assumption that firms operate in a completely free and competitive market, without taxes, or transaction costs, where information is readily and freely available. Under these conditions there is no optimal method of financing. Modigliani and Miller (1963) argue that, in the absence of taxes, the cost of capital remains constant as the benefits of using cheaper debt are exactly offset by the increase in the cost of equity due to increased risk.

When imperfect capital markets are taken into consideration, the capital structure of a firm becomes relevant. Since Modigliani and Miller's (1958) work, a number of theories have been put forward to explain the determinants of the capital structure of firms. These include the trade-off, the agency and the pecking order theories. Such theories take into consideration factors such as taxes, agency costs and information asymmetry that may cause deviations from the efficient market thereby reinforcing the market imperfection hypothesis. Details of the static trade-off theory are outlined in the ensuing section.

### 3.2.2 The Static Trade-Off theory

The static trade-off theory builds on the work of Modigliani and Miller (1958) to propose the existence of the an optimal capital structure for a firm, assuming the management of a firm will aim to maintain an optimal debt/equity ratio in making capital structure decisions to minimise the cost of prevailing market imperfections (Kraus and Litzenberger, 1973; Kim and Sorensen, 1986). The market imperfections include the tax shield benefits of debt finance, and the agency and financial distress costs of maintaining high debt levels (Haris and Raviv, 1990).

According to tax-based theories of capital structure, the financing decisions of a firm are influenced by the tax benefits of using debt and bankruptcy considerations. Tax paying firms are assumed to prefer debt over equity financing due to the fact that interest payments on debt are tax-deductible. Although tax benefits may encourage firms to use increasing amounts of debt in their capital structure, this may lead to an increase in the costs of financial distress and agency costs, putting opposing pressure on firms to avoid debt.

Financial distress costs arise when the likelihood that the firm may default on loan repayments is greater than zero. The more debt the firm uses in its capital structure, the higher the costs of financial distress resulting in banks adjusting the costs of the loan to take into account the potential risk that the company may go bankrupt. Agency costs arise from the of interest between equity and debt holders due to asymmetry in risk-sharing. These costs also increase as the amount of debt in a firm's capital structure increases (Jensen and Meckling 1976, Haris and Raviv, 1990). Equity holders tend to favour risky investments with a high rate of return whilst debt holders prefer less risky investments with guaranteed returns. Agency costs result from the need for debt-holders to monitor the behaviour of the equity holders so as to protect their own interests. Consequently, costly monitoring devices are often incorporated into loan agreements which result in higher costs of capital.

Under the static trade-off theory, firms trade-off the benefits and disadvantages of debt financing to maintain an optimal debt/equity ratio. Firms identify their optimal leverage by weighing-up the benefits and costs of using debt. Although there is empirical evidence that the static trade-off theory might provide a plausible explanation for the financing behaviour of firms in developed countries (Newman,

2010), there is weak support for its applicability to SMEs in both developed and developing economies (Watson and Wilson, 2002, Klapper et al., 2006). According to Watson and Wilson (2002), the explanatory power of the static trade-off theory is low and the results of empirical studies are inconclusive. This may be due to the difficulties faced by SMEs in accessing adequate sources of debt finance in comparison to larger companies which renders managers' inability to trade-off the benefits and costs of debt. Holmes and Kent (1991) purport that SME owners tend to operate without targeting an optimal debt/equity ratio. Thus the applicability of the trade-off theory of capital structure to SMEs is rather limited (Andree and Kallberg, 2008).

### **3.2.3 The agency theory**

Pioneered by Jensen and Meckling (1976), the agency theory proposes that under conditions of information asymmetry, self-interest and uncertainty, principals lack reasons to trust their agents and will therefore adopt measures to align the interest of the agents to those of the principal (Newman, 2010). Agency costs, resulting from the conflict of interest between equity and debt holders due to asymmetry in risk sharing also arise as the amount of debt increases in the capital structure. Jensen and Meckling (1976) identify two types of agency conflicts. The first focuses on the conflict between shareholders and managers and the second on the conflict between equity and debt holders. In the first instance, managers are tempted to pursue the profits of the firms they manage to their own personal gain at the expense of the shareholders. Thus managers cannot capture the entire gain from their value-maximising activities. According to Falkena, Abedian, Blottnitz, Coovadia, davel, Madungandaba, Masilela & Rees (2002) and Padachi, Narasimhan, Durbarry and Howorth (2008), the agency theory gives vital insights into the problems of ownership, management interrelationships and credit rationing.

The second type of costs, which arise as a result of conflicts between equity and debt holders, ultimately increases the cost of capital. In more practical sense, when firms are on the verge of bankruptcy, there is no incentive for shareholders to invest more equity capital, even if profitable projects are available. This is because the value derived from the projects will accrue mainly to the debt holders. The implication is that high debt levels may result in the rejection of value increasing projects.

For a large enterprise, the evaluation of an application for finance may be limited to the assessment of an audited set of financial statements and supporting documentation provided by the applicant. However, for SMEs the assessment normally goes beyond this, implying substantially higher transaction costs. Agency costs result from the need for debt-holders to monitor the behaviour of the equity holders in order to protect their own interests (Jensen and Meckling, 1976). Costly monitoring devices are therefore often incorporated into loan agreements which result in higher costs of capital for SMEs.

Two agency problems arising from information asymmetry include adverse selection and moral hazards, which can impact on the availability of credit and hence the capital structure of SMEs (Stiglitz and Weiss, 1981). These authors termed this phenomenon as credit rationing. Thus, credit rationing is said to occur firstly among loan applicants who appear to be identical, but discriminated against as some receive credit while others do not. Secondly, there are identifiable groups in the population that are unable to obtain credit or can only obtain credit at much higher prices. This underlying principle is at variance with the postulation that suppliers of finance may choose to offer a range of interest rates that would leave a significant number of potential borrowers without access to credit.

In terms of the agency cost theory, SMEs are expected to have the least debt and thus depend on internal equity. Debt levels gradually rise as the firm develops and becomes established. However, some authors disagree with the pattern of relationship as suggested by the agency theory. Frelinghaus, Mostert & Firer (2005) argue that whilst it is true that firms in latter stages do have more debt than firms in prime, the agency theory cannot explain why firms in the early stages of development have more debt than firms in prime. This argument therefore suggests the inadequacy of internal equity as a form of SME financing and the unavailability of external equity. The reliance of SMEs on debt finance therefore becomes inevitable.

According to Jensen and Meckling, (1976) fixed wage contracts cease to be the only means by which a relationship can be organised between banks and entrepreneurs under conditions of adverse selection and moral hazards. To ensure an agent's cooperation, principals may adopt measures such as monitoring and rewards tied to an agent's performance (Chittenden, Hall & Hutchinson, 1996). Such measures are

expected to reduce the problems of information asymmetry and agent opportunistic behaviour. However, the agent's motives may be influenced by factors such as financial rewards, labour market opportunities and other relationships outside the agent-principal relationship. Therefore, firms with relatively higher agency costs due to inherent conflict between the firm and debt-holders should have lower levels of external debt financing and financial leverage (Cassar and Holmes, 2003).

### **3.2.4 The pecking order theory**

The Pecking Order Theory (POT) was proposed by Myers (1984) and Myers and Majluf (1984) as an alternative approach to capital structure. The POT builds upon information asymmetry between managers and investors. According to the theory, due to agency costs, most firms prefer internal funding to external funding. Preference is given to funding sources with the lowest degree of information asymmetry as borrowing costs increase when obtaining funds from external financiers who do not have complete information on the borrower. The POT therefore implies that firms opt first, for internally generated funds in the form of retained earnings, then for debt, and only as a last resort for external equity (Degryse, de Goeij and Kappert, 2012). According to Myers (1984) there is no optimal debt-to-equity ratio to capital structure, and if there is, it is insignificant as compared to the cost of external financing. Baker and Wurgler (2002) therefore argue that raising external finance becomes costly as firm owners have more information about the prospects of the business than outside investors.

Internally generated finance is preferred because there are no problems of adverse selection. However, acute adverse selection problems are associated with equity. Therefore, in the mind of the investor, equity is considered riskier than debt and hence the investor will demand higher rates of return for equity investments than for debt (Myers and Majluf, 1984; Frank and Goyal, 2003). Another reason for equity investors demanding high rates of return is that it is costly and burdensome to float shares on the stock market. In addition, small firm owners avoid the use of equity finance for fear of losing control of their businesses to new external shareholders (Chittenden et al., 1996). Due to their small size and the high cost of issuing securities, SMEs are thus unable to issue publicly-held debt. Hence, SMEs tend to rely heavily on debt in the form of bank financing and trade credit (Coleman & Cohn,

2000). If debt financing becomes necessary, the SME managers are assumed to favour short-term debt because this does not tend to involve any demand for collateral security.

The applicability of the POT to SME financing in developing countries has been examined by a number of studies in recent years (Sorgorb-Mira, 2005). There is a general consensus in the empirical literature that the POT provides a much sounder theoretical explanation than the static trade-off theory for the capital structure adopted by SMEs (Sorgorb-Mira, 2005). A more constrained version of the pecking-order theory is suggested for SMEs than is the case for larger firms. It is thus indicated that smaller firms rely overwhelmingly on internal sources of finance in the start-up and development phases of the business life cycle.

In making a financing choice for the business, Newman (2010) argues that an entrepreneur considers the current situation in both the debt and equity markets. The current condition which is more favourable to the entrepreneur determines the financing decisions made. Businesses therefore are likely to defer fund raising in instances where debt and equity markets are unfavourable. Funds may however be raised even when they are not needed, when the current market conditions are conducive (Frank and Goyal, 2003). In their bid to sustain firm-growth, entrepreneurs borrow from both formal and non-formal institutional sources. The implications of this theory are that SMEs have a preference hierarchy for different types of finance in their financial policy. The factors that determine the capital structure of SMEs are discussed in the following section.

### **3.3 DETERMINANTS OF CAPITAL STRUCTURE OF SMES**

The capital structure decisions of firms, especially SMEs, have important implications for their performance, growth, risk of failure and potential for future development (Cassar, 2004). The inability to secure adequate sources of finance has been cited as the primary cause of SME failure (Coleman, 2000). It is therefore important to understand the entrepreneurial and business characteristics that determine the capital structure of SMEs. These factors are reviewed in sub-sections 3.3.1 to 3.3.2.

### **3.3.1 Owner manager characteristics**

According to Irwin and Scott (2010), the personal characteristics of the owner-manager influence the firm's ability and likelihood of accessing finance. The entrepreneur's financing decisions may be influenced by the strong desire to maintain business ownership and independence. To achieve this objective entrepreneurs prefer to use internal sources of capital (Abdulsaleh and Worthington, 2013) and reduce the use of external finance. Owners might perceive that any external providers of funds can interfere in the management of their business (Padachi et al., 2012). Characteristics such as owner's education, experience and age are reviewed in the following section.

- **Education and experience**

Theoretically the educational background of the SME owner-manager is often used as a proxy for human capital and has been found to be positively related to the firm's usage of leverage (Coleman and Cohn, 2002). In a study of SMEs owner-managed by men across the US between 1976 and 1986, Bates (1990) established that owner-managers with high levels of education were more likely to retain their firms operating throughout the period of study. Similarly, experience as measured by the number of years in an industry, has been found to enhance the availability of credit to SMEs (Cole, 1998). Empirical evidence indicates that prior experience of SME owner-managers in the industry is positively correlated with the share of external financing in the firm (Nofsinger and Wang (2011). In addition to that, the cumulative experience of entrepreneurs plays a significant role in mitigating problems like information asymmetry and moral hazard that hinder SME access to external finance. Therefore, the level of education and work experience provide the business with adequate human and social capital. According to Coleman and Cohn (2000), entrepreneurs with higher levels of formal education and business skills are more likely to source external finance.

- **Owner's age**

Similarly, the age of the business owner is likely to influence the capital structure decision of SMEs (Romano, et al., 2001). Unlike younger entrepreneurs, older business owners are less likely to invest additional finance into their firms.

Consequently, they are more reluctant to accept external ownership in the firm. Using data sets from the US and the UK, Vos, Yeh, Carter and Tagg (2007) affirm that younger owner-managers tend to use more bank credit than older entrepreneurs who appear to be more dependent on retained earnings

### **3.3.2 Business characteristics**

The characteristics of SMEs also affect their financial decisions and ultimately the firm's performance and growth. Corporate finance literature advocates for a number of factors that can be attributed to the cross-sectional variation in SME capital structure. These include firm size, age, asset structure, profitability, growth and risk (Abor and Quartey, 2010). This section provides an analysis of prior empirical literature on the most prominent factors that have been correlated to SME capital structure.

- **Firm size**

Size has been viewed as a determinant of a firm's capital structure. A number of reasons could be listed that justify the inclusion of size indicators to the capital structure of the firm (Cassar, 2004). Firstly smaller firms find it costly to resolve information asymmetry problems with potential lenders, resulting in limited access to finance or financing only being available at a higher cost (Newman, Gunesse and Hilton, 2013). Consequently it becomes more efficient for small firms to use internally generated funds than external sources (Myers, 1984; Barbosa and Moraes, 2004). Information costs are lower for larger firms due to better quality of financial information in terms of accuracy and transparency (Daskalakis and Psillaki, 2009). Secondly small firms face higher transaction and interest rate charges than larger firms who have the advantage of economies of scale to the financial institution (Cassar, 2004). Since transaction costs are fixed, financing costs are inevitably more costly for smaller firms. Thirdly, SMEs are perceived to possess greater operating risk than larger firms, resulting in lending institutions charging them higher prices for the loans or equity investments (Ortqvist, Masli, Rahman and Selvarajah, 2006). Thus smaller firms have far higher risk of bankruptcy as they tend to fail more often than larger firms. At the same time larger firms have diversified streams of revenue and established operations, making them more prone to succeed in the long run. Therefore size is expected to be positively related to leverage.



The empirical evidence regarding size as a possible determinant of firm leverage is mixed. On one hand, there is support for a positive relationship between firm size and capital structure of SMEs (Sogorb-Mira, 2005), while on the other hand some studies found a negative relationship in the short-run (Chittenden et al., 1996; Hall et al., 2004). These authors argue that small firms tend to depend mostly on equity while large firms are most likely to use debt. According to Newman et al., (2012) research conducted in developing countries has also established a positive relationship between firm size and measures of capital structure.

- **Age of the firm**

According to Abor and Biepke (2007) age is a standard measure of reputation and risk in capital structure models. Age plays a significant role on a firm's ability to acquire debt. Older firms are deemed to be more stable, and thus more reputable due to their ability to survive over a longer period of time (Diamond, 1991). Therefore, the prediction is that older firms tend to have more long-term debt in their capital structures. Empirical work on the relationship between age of a firm and its use of external finance is mixed. Petersen and Rajan (1994:24) found a significant relationship between age and leverage of small firms. Similarly, Barton, Ned & Sundaram (1989:41) concluded that mature firms experience lower earnings volatility and hence are expected to have higher debt ratios. Hall et al., (2004) found a positive relationship between age and long-term debt but negatively related to short-term debt. This suggests that the reputational capital held by older firms is sufficient to ensure that risk of default bank credit is minimised. In Ghana, Abor and Biepke (2007) also found that age is positively related to debt, suggesting that age is an important factor influencing SMEs' access to debt finance. The current study seeks to establish whether business age has any influence on the availability of bank credit for SMEs.

- **Asset structure**

The general consensus among researchers is that asset structure is directly related to leverage (Bester, 1985). However, due to conflict of interest between providers and shareholders, lenders face the risk of adverse selection and moral hazard. Therefore, lenders take action to protect themselves by requiring tangible assets. Collateral also provides a means to mitigate the risks of information asymmetry

between lenders and borrowers (Besanko and Thakor, 1987) thereby limiting monitoring costs or any extra risk acceptance required by firms with unsecured positions (Newman, et al., 2013). Hence asset structure is likely to be positively associated with capital structure of small firms. Furthermore, in the event of bankruptcy, a higher proportion of tangible assets could enhance the salvage value of the firm's assets (Stiglitz and Weiss, 1981). The lenders of finance are thus willing to advance loans to firms with a high proportion of tangible assets.

In general, empirical studies on SMEs in developed countries are in support of a positive association between asset structure and long-term leverage and a negative relationship between asset structure and short-term leverage (Chittenden et al., 1999; Cassar and Holmes, 2003; Sorgob-Mira, 2005). This emanates from the fact that small firms use internal sources of finance which do not require fixed assets as collateral in the short-term, while in the long-term, financing is secured against fixed assets (Newman, et al., 2013). Thus, assets function as guarantee in case of default (Harris and Raviv, 1991). Similarly, it has also been argued that collateral reduces adverse selection and moral hazard costs (Forte, Barros and Nakamura, 2013) for SMES with information asymmetry. Empirical evidence discussed so far provides strong support for the positive association between asset structure and leverage predicted by capital structure theorists. This is also evident for SMEs in developing economies as supported by studies in Ghana (Abor and Biepke, 2007) and in China (Huang and Song, 2006). It can be suggested that the firm's asset structure influences its use of debt finance. Without tangible assets, the firm cannot access bank finance and has to look for alternative sources of finance.

- **Profitability**

According to Myers and Majluf (1984), a negative relationship should exist between firm profitability and leverage. The authors contend that firms that are more profitable will prefer to use retained earnings, and thus will have lower debt ratios. External financing is only sought when it is absolutely necessary. It has also been argued that firms with better past performance have lower default risk and consequently a higher debt capacity. However, the trade-off theory posits that, in order to take advantage of the interest tax shields associated with higher leverage, more profitable firms will have higher debt ratios. In addition, profitable firms prefer not to raise external equity

in order to avoid potential dilution of control. Thus, an inverse relationship is expected between profitability and leverage.

A number of studies have tested the effect of profitability on firm leverage. The majority of empirical studies in the developed countries find evidence for the negative relationship suggested by Myers according to the pecking order theory. These include the works of Chittenden et al., 1996; Cassar and Holmes, 2003 and Sogorb-Mira, 2005. Likewise Abor and Biepke (2007) find a negative relationship for SMEs in South Africa and Ghana.

The evidence presented in the preceding discussion suggests that most small firms in both developed and developing economies follow a pecking order in their financing decisions. These findings confirm the predictions of Myers and Majluf (1984). In theoretical literature, profitability is measured as a ratio of earnings before interest and taxes (EBIT) to total assets. This then gives the impression that only unprofitable SMEs access bank finance.

- **Growth prospects**

Potential of business growth is another factor that influences the capital structure of small firms. The general consensus in the SME financing literature is that growth opportunities are negatively related to leverage, principally because future growth prospects are intangible and hence cannot be easily collateralised (Barclay and Smith, 2005). However, the effect of growth is dependent on the measure used to capture growth. Myers (1977) argues that firms with higher growth will have smaller proportions debt in their capital structure. In addition, high growth firms whose value comes from intangible growth opportunities do not want to commit themselves to debt servicing as their revenue may not be available when needed (Deesomsak, Paudyal and, Pescetto, 2004).

Empirical evidence seems inconclusive. According to Michaelas et al., (1999) future firm growth is positively related to leverage and long-term debt. With reference to South African SMEs, Abor and Biepke (2007) established that high growth prospects tend to entice more debt finance than those with low growth opportunities. This is evident in the positive relationship between long-term debt and the growth variable.

However, Chittenden et al., (1996) and Esperanca, Ana & Mohamed (2003) found mixed results.

- **Firm risk**

The level of risk is said to be one of the primary determinants of a firm's capital structure. According to Kim and Sorensen (1986), firms with high degree of business risk have less capacity to sustain financial risks, and thus use less debt. Theoretically, riskiness is expected to be negatively related to leverage. However, empirical evidence between risk and leverage for SMEs is limited and varied. Halov and Heider (2011) empirically examined the role of risk in the capital structure of firms. The authors argue that the traditional POT puts too much emphasis on the role of information asymmetry to explain financing decisions of firms. However, an important factor that has been ignored in the literature is the role of risk. SMEs face more severe information asymmetry problems than large and mature firms. But the POT fails to explain why small firms that are supposed to face more severe information asymmetry problems generally issue equity.

The legal form of the business also determines its financing decisions (Storey, 1994; Coleman and Cohn, 2000). Sole proprietors and partnerships are more likely to make use of internally generated sources of capital while companies and close corporations are more likely to make use of external funding since they exist as legal entities. Other factors that determine the capital structure of businesses include ratio of debtors to creditors, the nature of business operations (Cassar, 2004) and the economic sector they belong to (Harris and Raviv, 1991).

To summarise, the evidence documented suggests that firm specific characteristics such as size, age, profitability, asset structure, growth prospects and risk have an impact on firm financing. Firm profitability tends to be negatively related to leverage. However, with regards to size, the evidence is mixed with some studies reporting a positive association between size and leverage, while others suggest that a negative relationship exists. Asset structure appears to be positively correlated to leverage and growth prospects tend to be negatively related to debt. However, small businesses are characterised by information asymmetry problems resulting in high costs involved in resolving these challenges. Consequently, their choice and access to external finance is influenced by higher transaction costs than those of larger

businesses. The larger the firm, the more established it is likely to be, and the lower the degree of information asymmetry it is likely to face. The high business risk and information asymmetry increase if firms are small in operational size. Therefore, it appears that SMEs have to rely more on short-term than long-term debt. In the light of the above discussion, the next section reviews the various sources of finance available to owner-managers of small businesses.

### **3.4 SOURCES OF FINANCE FOR SMES**

An analysis of the capital structure of SMEs in the previous section revealed that initially small business owners rely on internal sources of capital such as personal savings and retained earnings to support their business operations (Bhaird and Lucey, 2006). As the business grows, external sources of funding such as debt from formal financial and non-financial institutions become important (Vos, et al., 2007). External sources of finance include venture capital, business angels, capital markets and trade credit. For the purposes of this study, the focus is on debt finance as discussed below.

- **Debt finance**

Due to the fact that internal equity is limited for most growing SMEs and external equity is not easily available and expensive, debt finance is therefore one of the financing options SMEs can use. Gitman (2009) describes debt as any financing vehicle that is a contractual claim on the firm, creating a tax deductible interest payment, with a fixed life and priority claims on cash flows in both the operating and bankruptcy periods. A distinctive feature of debt is that it has to be serviced (principal and interest) irrespective of whether the firm makes profit or not. The bootstrapping theory suggests that firms prefer to finance their capital requirements with external debt over external equity if sources of internal funds are exhausted (Winborg and Landstrom 2001). Most SMEs are more positively disposed towards debt funding from banks because this is a more attractive, realistic and obtainable source than external equity. Unlike equity finance, bank finance does not affect the ownership and management of small enterprises (Bruns and Fletcher 2008). Informed by their attractiveness to SMEs, Berger and Udell (2003) report that debt represents 50% of the capital structure of small firms in the US. The principal sources of private sector debt for SMEs are commercial banks and trade credit. Although the commercial

banks have the funds, it is difficult for SMEs to access these funds as will be discussed in the following section.

- **Bank Finance**

A large body of literature has documented that banks are the principal sources of debt finance for SMEs in both developed and developing countries (Coleman and Cohn, 2002; Zhou, 2009). Traditional forms of bank credit include term loans, overdraft facilities, factoring, leasing, export and import financing and government loan guarantee schemes (Uchida, 2011). Due to their extensive branch networks in the country, commercial banks can be easily accessed by SMEs, even in remote areas, and are therefore in a better position to gather information on SMEs. However, SMEs tend to face higher costs of financing because they typically create demand for smaller loans, they are less transparent and they have less collateral to offer as security. Thus banks act as financial intermediaries by gathering information about the borrowers (in this case SMEs) and monitoring them over time, and sometimes renegotiating the terms and conditions of the loan if and when the borrower defaults payment. Consequently, there has been an increase in bank-lending activities to SMEs in both developed and developing countries. The next section reviews the drivers of increased bank lending to SMEs.

### **3.5 DRIVERS OF SME BANK FINANCING**

Contrary to popular belief that banks are generally not interested in serving the SME market, new empirical evidence suggests that banks now perceive the SME segment as a strategic profitable part of their business (de la Torre, Martinez and Schmukler, 2008; Chironga, dahl, Goland, Pinshaw and Marnus, 2012). A number of factors have been put forward in support of this new paradigm in SME bank financing. Firstly, the banks' focus on SMEs is based on the perception that this segment's elevated profits more than compensate for the higher implicit costs and risks (World Bank, 2007b). The profitability is not only coming from lending products but from the potential of cross-selling. Calice et al. (2012) argue that a significant proportion of the bank's revenue comes from the fees they charge for the variety of fee-based non-lending products and financial services now offered to SMEs. In addition to that, profits from corporate banking are dwindling due to intense competition from capital markets and exposure to the retail sector (de la Torre, et al., 2008). Banks are

therefore looking for new markets to diversify their sources of income. Empirical evidence based on a survey in Argentina indicates that SMEs performed better than large companies during the 2001-2002 crises. The default rate for SMEs was lower than that of big firms and they recovered faster from the crisis.

Secondly, the SME lending market is now considered to be large, unsaturated and carries optimistic prospects. According to Chironga et al., (2012), an estimated 60% of global banking revenue growth in the next decade will lie in emerging markets. They further propound that it is estimated that bank revenues could jump from US\$150 billion in 2010 to US\$367 billion by 2015. Thirdly, banks have developed coping mechanisms and therefore no significant obstacles impede them from tapping into the SME market. In addition to relationship lending, banks are using different transactional technologies to extend financing to SMEs (Stephanou and Rodriguez, 2008). These include credit scoring, factoring, leasing and unsecured lending. Banks can thus use other types of hard information and other incentives to increase the likelihood of loan repayment. Fourthly, risk management is now an important aspect of SME financing, and banks have therefore developed the structure to deal with SMEs. Chironga, et al., (2012) concluded that banks have discovered a key, untapped segment and are making substantial investments to develop relations with SMEs.

The high level of perceived profitability and growth potential of the SME sector has been identified as the major motivation for the increased banks' involvement with the segment (Calice et al., 2012; de la Torre, et al., 2008). Using data from 91 banks from 45 countries, Beck, Demirguc-Kunt and Peria (2008:6), found that 81% of the banks from developed countries and 72% from developing countries identify perceived profitability of the SME sector as the most important determinant for their involvement. Banks argue that the potential profits which stem primarily from high loan spread more than compensate for the elevated costs and risks associated with SME funding (Stephanou and Rodriguez, 2008). Furthermore, banks are discovering the cross-selling opportunities available to them in having a large number of SMEs as depositors and not as borrowers. Diversification and market saturation in corporate banking are also seen as important drivers for increased SME involvement.

From the discussion above, it can be concluded that the SME segment is now being considered as a strategic sector with great prospects for growth. There is also possibility to seek SMEs through relations with existing large clients. However, in dealing with SMEs, banks face a number of obstacles which will be discussed in the following section.

### **3.6 OBSTACLES TO SME BANK FINANCING**

Although banks consider that the SME potential market is large, a number of obstacles are, however, constraining banks' further engagement with the SME segment, including SME-specific factors, macroeconomic factors and business regulation.

- SME specific factors such as informality, low quality accounting information and lack of adequate guarantees; firm's credit history with the bank, owner's characteristics and purpose of the loan complicate the assessment of the creditworthiness of SMEs resulting in increased transaction costs. For example, Calice et al., (2012), found that the lack of adequate and reliable information is the most important deterrent to banks' involvement with the SME segment in Kenya, Uganda, Tanzania and Zambia.
- Macro-economic factors such as political instability, taxes, disincentives to foreign investors and exchange rate risk have been documented to be important obstacles to bank lending to SMEs. Legal and contractual environment not of high significance to developing countries (Beck, Demirguc-Kunt and Peria, 2008; Calice et al., 2012). It is argued that perhaps banks adapt to the legal and contractual environment in which they operate by offering instruments that allow them to circumvent existing deficiencies (Rocha, Farazi and Pearce, 2011).
- Regulations impede banks to lend to SMEs with tax arrears, or those with impaired credit profiles at the credit bureaux.
- Lack of collateral and third party guarantees to address collateral issues (Uganda and Tanzania).
- Difficulty in standardising the risk assessment makes SME lending problematic. Banks have to adapt their commercial operational models in order to accommodate the peculiar needs of SMEs. Other banks are finding it



difficult to lend to SMEs the same products as those extended to corporate and retail clients (Calice et al., 2012).

- Other bank specific factors in the developing countries include lack of appropriate technology, skilled staff, general staff and operational inefficiency (Stephanou and Rodriguez, 2008).

In summary, there seems to be an increase in banks' involvement in the SME segment due to the sector's perceived high profitability and good prospects. Also from the preceding discussion, banks perceive macroeconomic instability in developing countries and competition in developed countries as the main obstacles impeding access to SME finance. The next section focuses on credit evaluation by commercial banks.

### **3.7 CREDIT EVALUATION BY COMMERCIAL BANKS**

Entrepreneurial activity is restricted by limited access to financial resources. The empirical evidence of capital market imperfections in the context of starting a business is widespread. According to Haris and Raviv (1991), one reason for the lack of financial resources available to SMEs is that banks hesitate to lend funds to businesses in general and to small enterprises in particular. In judging credit applications, banks face several serious information problems. Information asymmetries exist in the context of small businesses because of the relatively high fixed cost of gathering information, which banks are reluctant to incur on small transactions (Blumberg and Letterie, 2008). Furthermore, the smaller the number of repeated transactions, the smaller the incentives for banks to collect information. This is so because administrative costs increase due to economies of scale.

According to Bruns and Fletcher (2008), the major source of capital mobilisation is short-term loans (credit) rather than long-term loans (bonds) and equities (stocks). Small business owners are mostly involved in short-term credit markets. Lenders usually screen loan applications on the basis of borrowers' intention and ability to repay the loan because of the potential default risk associated with credit contracts (Dutta and Magableh 2006). Loan contracts, therefore, need to include both price interest (interest rate) and non-price provisions (collateral, market inter-linkage) as appropriate incentives for a loan repayment. Thus, entrepreneurs face a binding supply constraint because they are willing to pay a higher interest rate, hence price

rationing is non-existent. However, quantity rationing may set in, which takes the form of lenders offering an applicant a loan amount less than demanded or completely rejecting the loan demand.

When SME managers seek bank loans, it is important that they understand the logic of the lending officer's decision process in order to increase the chance of receiving credit and more importantly, to boost their credit rating profile (Bruns and Fletcher, 2008). A good credit rating enables firms to finance their capital requirements and decrease the cost of credit. A good credit rating also enhances the capability of the enterprise to generate external equity. According to Winborg and Landstrom (2001), bank loans have been found to be the most important external source of financing the capital requirements of SMEs.

Most SMEs are privately held and owner-managed and, therefore, less transparent. The enterprises have an information advantage with regard to external financiers. It must be noted that this information asymmetry can be used opportunistically by the borrower, which can restrain the willingness of banks to invest in the SME business (Giannetti, 2012). At an early stage, entrepreneurs may be hesitant to provide full information about the potential business opportunity because of concerns that disclosure may make it easier for competitors to exploit (Shane and Cable, 2002).

In a study of bank's risk assessment of Swedish SMEs, Bruns and Fletcher (2008) examined the factors that lending officers actually use when deciding whether to grant credit to SMEs. They established that banks place the strongest emphasis on the tangible accounting figures that are presented by SMEs, and factors that shift the risk from the bank to the borrower. In addition, the general risk taking appetite of the borrower interacts with the financial position of the borrower and the collateral that is provided. For new ventures that lack a track record, and SMEs that have a weak track record, it is difficult to get loans from the banks. As such, the prescript notion of developing a strong business plan for a project to be financed is not the way forward for SMEs, but rather, they are expected to show that they have the competence to perform the activities that are contained in the proposed project. In addition, they need to provide strong collateral such as private property.

In a study of SMEs' access to bank finance in Scotland, Deakins, Whittam and Wyper (2010) investigated the factors that affect decision making by bank managers

based on real entrepreneur case scenarios of debt funding applications. Using data from the 2005 Annual Small Business Survey (ASBS), the authors established that a significant minority of Scottish entrepreneurs had experienced problems in accessing finance from banks. The supply-side interviews with bank loan officers reveal that banks have standard financial 'models' that are followed in terms of financial requirements, although there may be considerable discretion exercised by individual bank loan officers, dependant on seniority. It was also found out that younger entrepreneurs with limited security found it difficult to raise finance for propositions that contain higher risk or do not meet the banks' financial modelling requirements. In addition to information asymmetry, trading records and the nature of relationship banking are important factors that determine the access to finance by SMEs in Scotland.

### **3.8 FACTORS DETERMINING THE CREDIT RATIONING BEHAVIOUR OF BANKS**

According to Coleman and Cohn (2000), commercial banks are the principal source of debt finance for SMEs, offering a wide range of services including overdraft facilities, term loans, trade bill financing, factoring, leasing, export and import finance, and even government loan guarantee schemes. Products offered by banks to SMEs include credit cards, hire purchase, current and savings accounts. However, all these services and products require documentation from SMEs, but because of information asymmetry the majority of SMEs in South Africa fail to satisfy the criteria used by banks for screening their clients.

However, the credit rationing behaviour of banks may be influenced by a number of factors which include the borrower's observable characteristics (age, gender, wealth, experience, credit history), firm characteristics, (business experience, risk profile, income), and loan characteristics (loan size, loan maturity, collateral offered, interest rate). According to Lapar and Graham (1988) the bank's credit rationing behaviour against the firm's loan demand can be categorised into three stages namely: the screening stage, the evaluation stage, and the quantity rationing stage. At the screening stage, the eligibility of the borrower for credit is determined in terms of credit worthiness, loan requirements and the terms desired. At this point, the decision whether the applicant qualifies to apply for a loan or not is made. At the

evaluation stage, a detailed analysis of the viability of the proposed investment is done. This includes an investigation of the credit record, the type and value of the collateral, management of the firm and probability of repayment. Details of the requirements of SMEs by the bank at the screening and evaluation stages are shown in the Figure 3.1.

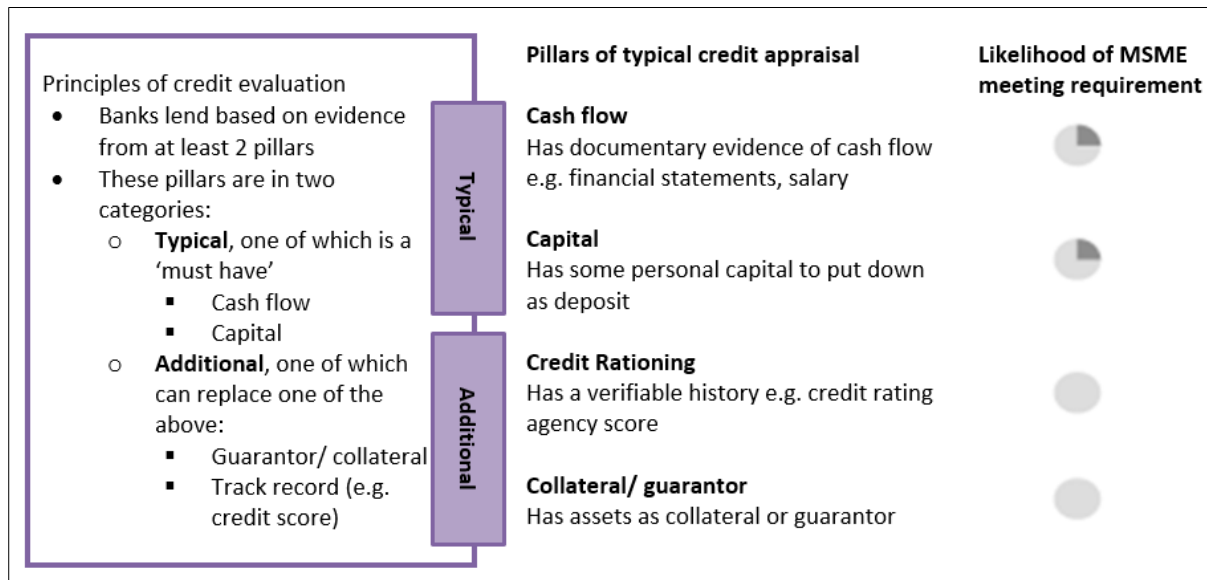

**Figure 3.1:** The credit evaluation process

Adapted from the McKinsey Report, 2012

As shown in the Figure 1, it is mandatory for SMEs to have documented evidence of cash flow such as financial statements or payslips; and personal capital to put down as collateral. In addition, SMEs should have a verifiable credit history such as a credit rating from the credit bureau or collateral. If collateral is not available, a guarantor can be used instead. It can thus be deduced that the likelihood of SMEs meeting these requirements is very low and this explains why the majority of small businesses are credit rationed. Owner information, which forms an integral part of the SMEs evaluation, is personal information, which is inadequately disclosed to financial institutions. A decision to determine whether it will be profitable for the bank to grant the loan or not is done based on the evaluation result. Therefore, those SMEs found not to be credit worthy are denied loans completely (credit rationed).

At the final stage of quantity rationing, the bank determines the optimal loan size for a borrower at a given interest rate based on a firm's probability of repayment, the

marginal cost of granting the loan, and the collateral offered (Freel, 2007; Baas and Schrotten, 2006). Thus, some borrowers are granted loan amounts less than what they applied for. According to Laper and Graham (1988), the bank adjusts the loan contract to reflect the bank's evaluation of the riskiness of the loan and the impact of these risks on expected profit. Thus credit rationing can be regarded as a form of risk management on the part of the banks where they seek to minimise the costs of production and create value for their shareholders.

The risk profile of a firm is an important factor that determines whether a bank extends credit to an SME or not (Hoff and Stiglitz, 1990). Firms for which the repayment of loans is uncertain are more risky for the bank and hence are more likely to be credit rationed. In this instance the bank is threatened by default risk, being the risk that the SME cannot fulfil its obligations to the bank at a given time according to an agreement. The degree of risk of the firm may be inferred from its credit history, the expected returns of the project and business experience of the firm. In the case of South African SMEs, most small businesses fail to satisfy these requirements due to information asymmetries and are thus credit rationed. Banks perceive SMEs as risky because, they face a more uncertain competitive environment than larger firms. As such, SMEs experience more variable rates of return and higher rates of failure. In South Africa, the risk perception on SMEs is endorsed by the high failure rate of about 75% (FinMark Trust, 2006) and it is therefore reasonable for banks to ration credit to SMEs. The environment in which SMEs operate is perceived to be risky. For example; crime and labour unrest in South Africa (Fatoki, 2012), may have a negative impact on the security of transactions. It may also be argued that credit rationing may also originate from a lender's inability to classify loan applicants into proper risk categories due to information opacity (Zambaldi, et al., 2009).

As an instrument of risk management, collateral is also regarded as very relevant to credit granting decisions (Laper and Graham, 1988). Collateral serves as the last resort for recovery of the loan in case of default, and where the bank can sell the collateral obtained to recover the balance (or part) of the loan. In reality, the bank has limited information (imperfect information), and limited control over the borrowers actions (incentive effect). This leads to what is known as 'Collateral and Limited Liability Theory' in which financial institutions, especially banks, use collaterals as a

way to reduce the risk of default and, concurrently, increasing their return on invested capital (Arroyo, 2007). This mechanism, by which the bank increases the liability of the borrower, should the project fail, leads to different perceptions of the risk and return of the project from both parties (Arroyo, 2007). Collateral helps to reduce information asymmetry and moral hazard problems that could arise between banks and small business owners (Coco, 2000). Due to the fact that most SMEs are not formally registered and therefore lack a credit record, banks consider collateral as attractive security. The willingness to offer collateral thus signifies the confidence of the small business owner's commitment in the business. Thus according to Smit and Fatoki (2012), collateral positively impacts on the risk perception of the entrepreneur and the business.

The loan size and length of the loan's maturity period required by the borrower may also influence a bank's credit rationing behaviour. The longer the maturity period, the greater the risk of loan defaults. This is due to the uncertainty of long-term investments as circumstances of borrowers may change overtime thus increasing the probability of a borrower being credit rationed. The loan size affects credit risk, since a loan tends to become riskier as its size becomes larger (Stiglitz and Weiss, 1981; Hashi and Toçi, 2010). According to Lapar and Graham (1988), the observable characteristics of the borrower (level of education, income, wealth and asset values) are argued to reduce the borrower's probability of being credit rationed. These factors tend to raise the borrower's credit rating and thus reduce the probability of loan default.

Under South African banking regulations, various forms of assets including land, buildings, houses, investment instruments and equipment can be used as collateral. Borrowers who do not have their own land or buildings find it difficult to meet the arduous requirements for collateral imposed by banks. Therefore, a lack of assets that can be used as collateral is one of the major constraints that results in the low proportion of lending to SMEs.

### **3.9 TECHNIQUES USED IN SME BANK FINANCING**

According to Ashton and Keasey, (2005) lending decision-making is central to the operation of SME banking services and relies on the type and suitability of the lending technology that is used. A transactional lending technology refers to a bank-

firm relationship in which the bank obtains verifiable quantitative information from the borrower that the loan officer can credibly communicate to others in the bank, such as audited financial statements, collateral values and credit scores (Berger and Black, 2011). The principal lending technologies that can be employed for lending decision-making include financial statement lending, asset-based lending, small business credit scoring, factoring and leasing as discussed below.

According to Berger and Udell (2006), financial statement lending is a transactions technology based primarily on the strength of a borrower's financial statements. For this technology there are two requirements that depend on hard information, namely the possession of detailed financial statements, such as audited statements and a strong financial condition as reflected in the financial ratios calculated from these statements (Berger and Udell, 2006). Unlike other lending strategies, financial statement lending is reserved for firms with relatively transparent information. According to Berger and Black (2011), large institutions like commercial banks can equally engage in SME financing. Uchida (2011) asserts that commercial banks have a comparative advantage in transactions lending to SMEs based on "hard" information, while small lenders have a comparative advantage in relationship lending based on "soft" information.

Small business credit scoring is another transactions technology based primarily on hard information about the SME's owner/manager as well as the firm. Owner information is personal data obtained from consumer credit bureaus. The data is pooled together with information on the SME that has been collected by the lender and entered into a loan performance prediction model which yields a score, or summary statistic for the loan. Empirical evidence suggests that credit scoring increases credit availability for SMEs. Berger, Frame and Miller (2005) affirm that implementing credit scoring leads to an increase in the supply of credit to SMEs. Furthermore, Berger et al., (2005) further establish that the adoption of the credit scoring technology by banks included in their sample increased the portfolio share of SMEs by 8.4%. According to Berger and Frame (2007), the increase can be categorised into various forms namely: increasing the quantity of credit extended, increasing lending to relatively opaque, risky borrowers, lending over greater distances and increasing loan maturity. Small business credit scoring may be applied even when there is very limited information about the quality of the firm, as long as

the firm has a good credit score based on the credit history of the owner (Berger and Black, 2011).

Likewise, Berger and Udell (2002) suggest that credit scoring is a method for making lending-decisions which uses statistical techniques to analyse appropriate data. These authors further suggest that credit scoring techniques require a lot of data about the firm and the firm owner, and it also needs to factor in the experience gained from lending to other firms. The data is entered into a loan performance prediction model, which yields a score, or summary statistic for the loan. Like financial statement lending, this technique is appropriate for firms with long credit history, which may reduce its importance as a tool for SME lending in developing economies.

Asset-based lending is a transactions lending technology in which financial institutions address the information asymmetry problem by focusing on a firm's assets which are pledged as collateral, as the primary source of repayment. In simple terms, it is any kind of lending secured by an asset (Uchida, 2011). This involves lending to business or corporations using assets that are not normally used in loans other than mortgages. Typically, these loans are tied to inventory, accounts receivable, machinery and equipment. This type of lending provides working capital financing secured primarily by accounts receivable and inventory (Berger and Udell, 2006).

According to Berger and Udell (2006), the use of collateral itself does not distinguish asset-based lending from other lending technologies. The pledging of accounts receivable and inventory is often associated with financial statement lending, relationship lending and credit scoring, where collateral is used as a secondary source of repayment. With asset based lending, credit extension is based on the value of the collateral and not the overall creditworthiness of the firm. According to Coco (2000) collateral helps reduce information asymmetry and moral hazard problems that could arise between banks and small business owners. Due to the fact that most SMEs are not formally registered, and therefore lack a credit record, banks consider collateral as attractive security. The willingness to offer collateral thus signifies the confidence of the small business owner's likely success in the business.



Thus according to Fatoki and van Ardt Smit (2011), collateral positively impacts on the risk perception of the entrepreneur and the business.

Factoring is another transaction technology that employs hard information to lend to opaque SMEs. According to Soufani (2002) factoring is a method used to raise short-term finance whereby clients' account receivables are purchased by a bank for a pre-agreed fee plus interest. The bank then takes the responsibility to control and manage a debtor portfolio of the firm. Put simply, factoring is the process of exchanging the account receivable of a firm for cash (Abdulsaleh and Worthington, 2013). Thus accounts receivable can be used as collateral for SMEs that usually lack security to raise finance. As an alternative source of finance, factoring can play a crucial role in alleviating financing gaps faced by SMEs (Soufani, 2002). However, factoring has been used effectively in the developed countries such as Italy and Switzerland and less in developing and emerging markets such as Africa (Berger and Udell, 2006). According to Uchida and Udell (2010), factoring may be particularly useful in countries with weak secured-lending laws, inefficient bankruptcy systems, and imperfect records of upholding seniority claims, because factored receivables are not part of the estate of a bankrupt SME.

Leasing is a common method of financing equipment, motor vehicles, and real estate by financial institutions in developing and emerging markets, including South Africa. The lender (the lesser) purchases fixed assets, and immediately enter into a rental contract with the lessee (the borrower, in this case the small business owner) which specifies the payment schedule. At the end of the contract the lessee has the option to purchase the assets at a pre-specified price. Leasing is thus a transactions technology which can be used to finance opaque firms since the underwriting decision is primarily based on the value of the asset being leased.

Relationship lending technology is used to reduce problems of information asymmetry in firms, especially SMEs. Banks gather "soft" information through continuous contact with the firm in the provision of financial services (Berger and Udell, 1998; Carbó, Rodríguez and Udell, 2011). The information is then used to evaluate the creditworthiness of the owner-manager as part of the loan process to ensure that the potential loan will be repaid. An important characteristic of such a relation to the lender is the increase in the value of the information gathered (Baas

and Schrooten, 2006). Therefore loan interest rates are expected to decrease over time as the relationship strengthens.

Several studies have proposed theoretical models of “relationship lending”, which consistently show that borrower-lender relationships provide valuable private information on the financial prospects of potential borrowers (Diamond, 1991; Rajan, 1992; Boot and Thakor, 1994). It is generally argued that relationships would have a positive association with the availability of debt finance. However, Petersen and Rajan (1994) found a positive correlation between the strength of the relationship measured by its duration and the availability of credit for SMEs. Other benefits of relationship lending as reported in the literature include lower cost of credit, protection against credit crunches and the provision of implicit interest rate or credit rate insurance. Hernandez-Canovas and Martinez-Solano (2010) suggest that trust-based relationship lending is more effective than the establishment of a longer or more concentrated bank-borrower association.

The impact of long-standing bank-firm relationships on availability of credit has been investigated in several countries, mainly in the context of small business finance. In the US, using the data from the National Survey of Small Business Finance, Peterson and Rajan (1994) found that the duration of relationship significantly increases credit availability, but has little impact on the cost of capital. The authors also report that older firms enjoy easier access to credit at lower costs and that borrower firms that attempt to widen the circle of relationships by borrowing from multiple lenders face higher costs as well as reduced availability of credit. Using the same data but examining only firms borrowing on credit, Berger and Udell (1994) found that borrowers with longer banking relationships are more likely to obtain credit at lower costs.

The main lending technology used for SME lending in South Africa is the traditional scoring model. However, SMEs rarely possess the information required for traditional credit scoring due to information asymmetries. This is so because the majority of people do not have a good credit record because they have been blacklisted, and it is difficult and costly for them to clear their record (Musara and Fatoki, 2012). Like financial statement lending, credit scoring is appropriate for firms with long histories, which may reduce its importance as a tool for SME lending in developing economies.

Credit scoring is also able to provide automated accept/reject decisions in high volume environments and therefore makes it a suitable lending technique for commercial banks. Indirectly this is a form of risk management as banks endeavor to minimize losses resulting from SME lending.

Another approach used in SME assessment is the credit assessment or analysis in the measurement of credit risks. The borrower's credit assessment is done using the five Cs of lending, namely character (willingness of the customer), capacity (ability to pay), capital, collateral (pledged assets) and general economic conditions. It is interesting to note that two factors (capacity and capital) are based on hard information, character refers to soft information and economic conditions refer to the external environment while collateral is needed when insufficient hard and soft information to grant credit are available (Fatoki and van Ardt Smit, 2011). However, it has been argued that the credit lending behavior is not only determined by internal factors alone, but by external factors as well. These determinants include demand, competition, and macroeconomic environment, regulatory, social and institutional factors. Banks do not have control over external factors and thus, it would be in their best interest to work closely with the government.

The most common findings in the extant literature are that banks have comparative advantages in transactions lending to more transparent SMEs based on formal documents, while relationship lending suites most to those SMEs with information asymmetry. Therefore, SMEs may be constrained in the financing they can obtain through transactions approaches offered by the banks. Therefore, depending upon the borrower's characteristics and financial needs, innovative lending technologies may be used to supply funding even when relationship lending cannot be effectively employed.

### **3.10 CHAPTER SUMMARY**

The chapter focused on the financial theories of capital structure of small businesses and SME financing in general. From this review of literature, it is evident that access to SME financing is an important topic in the banking industry both in developed and developing economies. It seems that the financing decisions of SMEs are jointly determined by the capital structure of the firm and the entrepreneurial and business characteristics.

An analysis of the literature on the capital structure of SMEs has shown that initially small businesses rely on internal sources of capital such as personal savings, gifts from family and friends and retained earnings to support their business operations. As the business grows external sources of funding such as venture capital, business angels, capital markets, trade credit and bank credit become important. However, bank credit appears to be the most common source of finance due to the accessibility and distribution of bank branches geographically.

Section 3.5 reviews the drivers of increased bank lending to SMEs in the past few years. Hence banks now perceive the SME segment as a strategic profitable business. However, in dealing with SMEs, banks face a number of challenges including SME specific, factors, macro-economic factors and regulatory issues.

Although banks are the principal source of debt finance for SMEs, they ration the credit they give to the small businesses. This credit rationing behaviour is influenced by a number of factors including the borrower's observable characteristics, firm characteristics and loan characteristics. The rationale is that these factors tend to raise the borrower's credit ratings, hence reducing the probability of loan default to the lender.

The chapter also reviewed the lending technologies used by banks in financing SMEs. It was established that the principal lending technologies employed by banks for lending decision-making include financial statement lending, asset-based lending, credit scoring, factoring, leasing and relationship lending. However, due to information asymmetry, these lending techniques do not suit the funding requirements of small businesses. Therefore banks are encouraged to adopt innovative techniques which are directed specifically to satisfy the financial needs of SMEs.

The next chapter focuses on the credit rationing concept and the risks associated with bank lending to SMEs.

## **CHAPTER 4**

### **CREDIT RISK MANAGEMENT: A CONCEPTUAL FRAMEWORK**

#### **4.1 INTRODUCTION**

In this chapter, literature on credit rationing and the risk management associated with bank lending to SMEs is explored. Empirical evidence has shown the existence of excess demand over supply, leading to the credit rationing of loan applicants. As indicated in chapter one, the aim of this study was to investigate the factors that militate against SMEs' access to funding from commercial banks. In this chapter, more emphasis was directed towards understanding the credit rationing concept. The chapter also discusses other bank-specific factors that negatively influence SME financing, such as credit risk management, innovation and technology.

The chapter proceeds as follows. The first section discusses the basic notions of financial market imperfections. Subsequent sections discuss the theory of credit rationing, credit risk management and innovative strategies associated with SME bank financing. Electronic banking as a factor of credit supply to SMEs is also discussed. The last section presents a summary of the chapter.

#### **4.2 IMPERFECT MARKETS AND INFORMATION ASYMMETRY**

According to Jaffee and Stiglitz (1990:838), credit markets differ from standard markets in two important ways. On the one hand, credit markets are characterised by a homogeneous commodity where delivery of and payment for the goods occur simultaneously. On the other hand, standard markets are characterised by postdated obligation; in that, credit received today is exchanged for a promise to repay in the future. Furthermore, promises to repay the loan are not the same, as one person's promise might not be as good as another's. Further, there might not be an objective way to detect the likelihood that the promise will be kept. Hence, an element of uncertainty is brought into the credit market.

Under conditions of uncertainty, access to information about potential risk and return on investment that are associated with the funded project, plays an important role. It is assumed that borrowers know more about their own risk characteristics (i.e. if they are high- or low- risk averse) and the risk characteristics of the projects they are

engaged in (i.e. they know the expected return and risk of the project) than do the institutions they are borrowing from. Borrowers know only the expected return and risk of the average project in the economy. In such a situation, financial markets are therefore characterised by information asymmetry.

For credit markets, information asymmetry creates problems on two fronts namely: *ex ante*, i.e., before the transaction is entered (adverse selection) and *ex-post*, i.e., after the transaction is entered (moral hazard). There are a variety of ways and devices that can be used by lenders to reduce the information gap, encourage positive and discourage high-risk actions, and finally to reduce their losses in case of default by borrowers (Colquitt, 2007). However, these instruments can only mitigate the risk of exposure of the lender, but not eliminate it. Consequently, there is no equilibrium in the credit market (where demand is equal to supply), and credit rationing may follow. The process of credit rationing is summarised in Figure. 4.1 below:

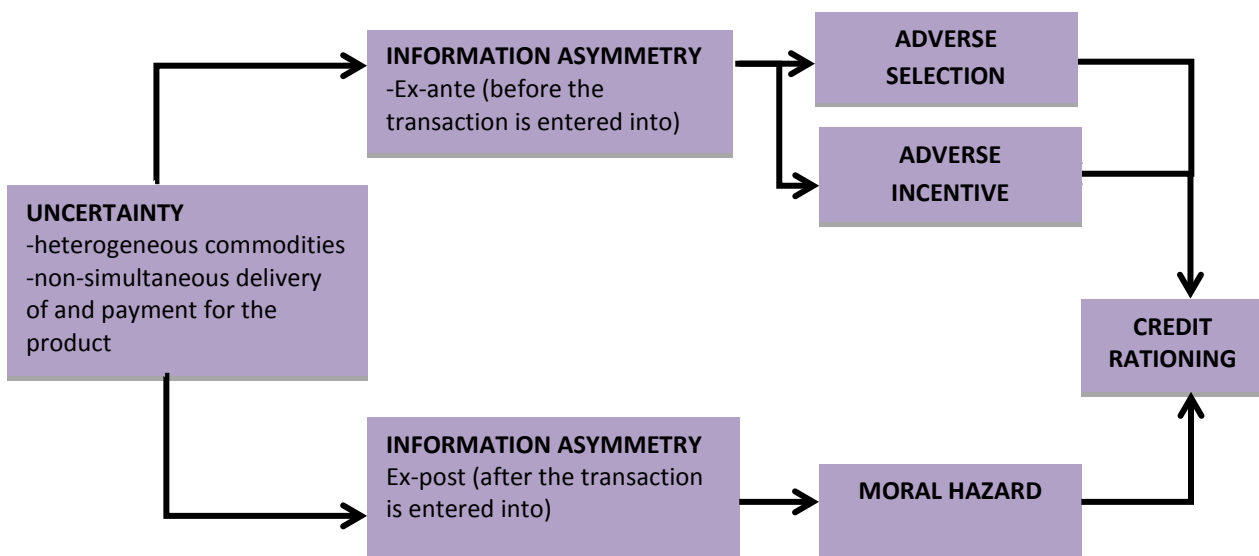

**Figure 4.1:** The credit rationing process

Source: Author's own compilation

Figure 4.1 above presents a simplified graphic representation of interrelations between credit rationing, uncertainty, information asymmetry, adverse selection and

moral hazard, while the following sections provide the theoretical background concerning these issues.

#### **4.2.1 Problems created by information asymmetry**

According to Stiglitz and Weiss (1981), the main causes of credit rationing include adverse selection and moral hazard that occur as a result of information asymmetry. In the case of information asymmetry, the party lacking the information (principal) would search for relevant information in the market, while the other party (agent) who has access to information would spread useful information to the market. Stiglitz and Weiss (1981) further suggest that in applying the principal-agent theory, the SMEs are in possession of vital information that relates to their financial position and earnings, which is usually impossible for financial institutions to obtain in good time. The fact that SMEs are largely unwilling to divulge this critical information precipitates information asymmetry, which culminates credit rationing.

The problem of adverse selection arises when borrowers withhold private information about their personal behaviour and/or the project they want to invest in, before the credit relationship begins. By the same token, lack of information prevents bankers from perfectly distinguishing between good and bad firms (e.g. between firms characterised by low-risk and/or high expected profits, and high-risk and/or low expected profits).

To reduce the perceived risk, the lender can use interest rates as direct screening mechanism to differentiate the risky borrowers/projects from the safe ones. High risk firms tend to be more prepared to pay high interest rates to obtain funds. Consequently, low-risk individuals and firms tend to drop out of the market since they know that they will be paying higher interest rates than they ought to have paid (Stiglitz and Weiss, 1981). This gives rise to adverse incentive effects because as the average riskiness of those who borrow increases, the average quality of borrowers tends to deteriorate (Jaffee and Stiglitz, 1990).

According to Jaffee and Russell (1976), the bank cannot use the interest rate as a signalling mechanism. This analysis of credit markets is contrary to the classical teachings of the market mechanism. When there is an excess demand for loans at a given interest rate, classical economic analysis would suggest that the price (interest

rate) would rise to block off excess demand. But in the case of information asymmetry, the lender will choose to keep the interest rate low enough to obtain a favourable risk composition of projects and to ration the available loanable funds through other means. As a result, the interest rate does not rise, hence demand may exceed supply.

After the transaction has been entered into, information asymmetry can generate another problem known as moral hazard. Because the borrower has more information about his activities than the lender, the borrower's actions affect the incomes of both parties to a different extent. In short, there is a conflict of interest. Once one has acquired a loan, one is more likely to invest in higher yielding but more risky projects, since the profit will be higher if successful. Furthermore, by raising the interest rate, the lender reduces the expected marginal return to the borrower, thus increasing the incentive for the borrower to undertake undesirable actions. As the firm's expected marginal profit decreases with increased credit price, the borrower may undertake projects with lower probability of success but higher profits when successful (Jaffee and Stiglitz, 1990).

According to Zambaldi, et al. (2009), adverse selection and moral hazard relate inversely to the age and size of the firm. Availability of public information about SMEs is limited due to the poor quality of their accounting records and low incentives to operate formally. Further, Baas and Schrooten (2006) suggest that information asymmetry is one of the reasons why small businesses are confronted by challenges of constrained access to funding. Hartarska and Gonzalez-Vega (2006) also posit that financiers are largely unable to solve the problems of information asymmetry, thereby inhibiting the possibility to adequately fund small business expansion projects.

From the ongoing, it becomes evident that adverse selection, adverse incentive and moral hazard derive directly from the imperfect information present in the financial markets. Given that financial markets are largely characterised by uncertainty and information asymmetry, lenders are forced to protect the interest of banks by reducing default rates, especially by attracting low-risk borrowers. The various possibilities are explored in the section that follows:



#### **4.2.2 Solutions to problems created by information asymmetry**

In order to alleviate the problems generated by information asymmetry, lenders tend to engage in information-producing activities, which in most cases, may lead to the closure of the information gap and loss-reduction. These activities encourage borrowers to undertake actions that are not in conflict with the lender's interest. Information-producing activities are intended to reduce the risk the bank faces before and after a transaction. Such activities include, for example, screening and monitoring.

Screening is aimed at reducing the risk before the transaction, thereby helping to reduce adverse selection problems. Information from and about potential borrowers is collected and assessed for creditworthiness. Safe borrowers are filtered out from the pool of seemingly identical applicants. After the credit risk appraisal, the lender is then able to determine whether to grant the loan and, under what conditions. According to Shikimi (2013), riskier borrowers could be charged higher interest rates and non-price terms to mitigate the higher likelihood of default or rationed by rejecting the applications at a given interest rate.

Once the contract is signed, banks monitor the activities undertaken by the borrower and determine whether they are in harmony with the provisions (restrictive covenants) written into the contract (Bellier et al, 2012). The borrower can be penalised for bad behaviour by being forced to pay back the loan immediately if the outcome is negative. Thus, the *ex-post* risk is reduced and the moral hazard problem could be alleviated.

However, it should be noted that the efficiency of a credit approval process is dependent upon how much time and money is spent on both screening and monitoring. The bank can explore several ways of reducing the screening and monitoring costs, but this may result in less reliable information (Gianneti, 2012). Although both methods help reduce information asymmetry problems, they do not eliminate them completely, and therefore lenders look for other ways of reducing possible losses.

To prevent moral hazard from occurring after the transaction (*ex-post*), lenders attempt to devise a contract which will prevent borrowers from engaging in activities

that are in conflict with the lenders' interest and reduce the lender's losses in the event that a borrower defaults (Bellier et al., 2012). Therefore, non-interest price or non-price terms of the loan contract can be employed. Such mechanisms include the use of collateral, cash contribution by the applicant, net worth analysis (equity capital) and long-term customer relationships.

Following from the ongoing, it has been demonstrated that uncertainty and information asymmetry give rise to imperfect credit markets, which in turn give rise to adverse selection and problems relating to moral hazard. Consequently, it becomes very difficult for lenders (banks) to differentiate between credible and implausible potential borrowers. This specific challenge poses a potential threat to accurate risk-evaluation of credit applicants. The sensitivity of this challenge have been observed as the main culprit for credit rationing. The next section discusses the credit risk associated with SME financing by banks.

#### **4.3 CREDIT RISK MANAGEMENT FOR SMEs**

Banks experience a variety of risks including credit risk, capital risk, investment risk, interest rate risk, market risk, operational and currency risk. However, the most fundamental of these risks, for the purposes of this study, is credit risk, also known as default risk, and, for that reason, it is worthy of special mention in bank lending research for SMEs. It is recognised that the intelligent and responsible management of credit risk makes it one of the bank's largest profit drivers (Calice et al., 2012) and hence the management of credit risk is central in the bank's SME credit management process. According to (Colquitt, 2007), credit risk is the potential that a bank borrower/counter party fails to meet the obligations on agreed terms. For one reason or another, there is always a possibility of a borrower defaulting on his commitments (moral hazard), resulting in the crystallisation of credit risk to the bank. The inability of the SME to pay interest payments (or repay the principal) can result in a default that might lead to loss for the bank. This explains why banks ration credit to SMEs.

Credit risk is believed to be the central risk in financial banking intermediation. In the area of lending, credit risk arises through the provision of loans and contracts to support a client's obligations (Young 2006:2), while in trading activities, credit risk results from the possibility that the party with whom the bank is trading is unable to

fulfil its contractual obligation on or before the settlement date. According to (Berg and Fuchs, 2013), credit or default risk refers to the uncertainty associated with borrower's repayment of their loans. For creditors, the potential loss that may arise may be due to a borrower's non-payment for matured liabilities. The borrower's non-payment may be a result of either the inability or unwillingness to perform as per contract or a decline in the borrower's credit quality. According to Kundid and Ercegovac (2011), credit risk is thus a probability of partial or complete value reduction of receivables.

The goal of credit risk management is to maximise a bank's risk-adjusted rate of return by keeping credit risk exposure within acceptable parameters. As such, banks need to manage the credit risk inherent in the entire profile as well as the risk of individual transactions, while at the same time managing the relationships between credit risk and other risk types. Although other sources of credit risks exist throughout the activities of the bank, loans are the largest and most obvious source of credit risk (Colquitt, 2007). Therefore, the long-term success of any banking institution is dependent upon an effective and efficient management of credit risk.

A credit risk management process includes many phases, namely credit risk identification, measurement of credit risk, strategy of response to credit risk and fourthly, constant credit monitoring and control. According to Berger and Udell (2006), such activities are termed "lending technology – a unique combination of primary information source, screening and underwriting policies/procedures, loan contract structure and monitoring strategies and mechanisms". The credit risk management process is depicted in Figure 4.2.

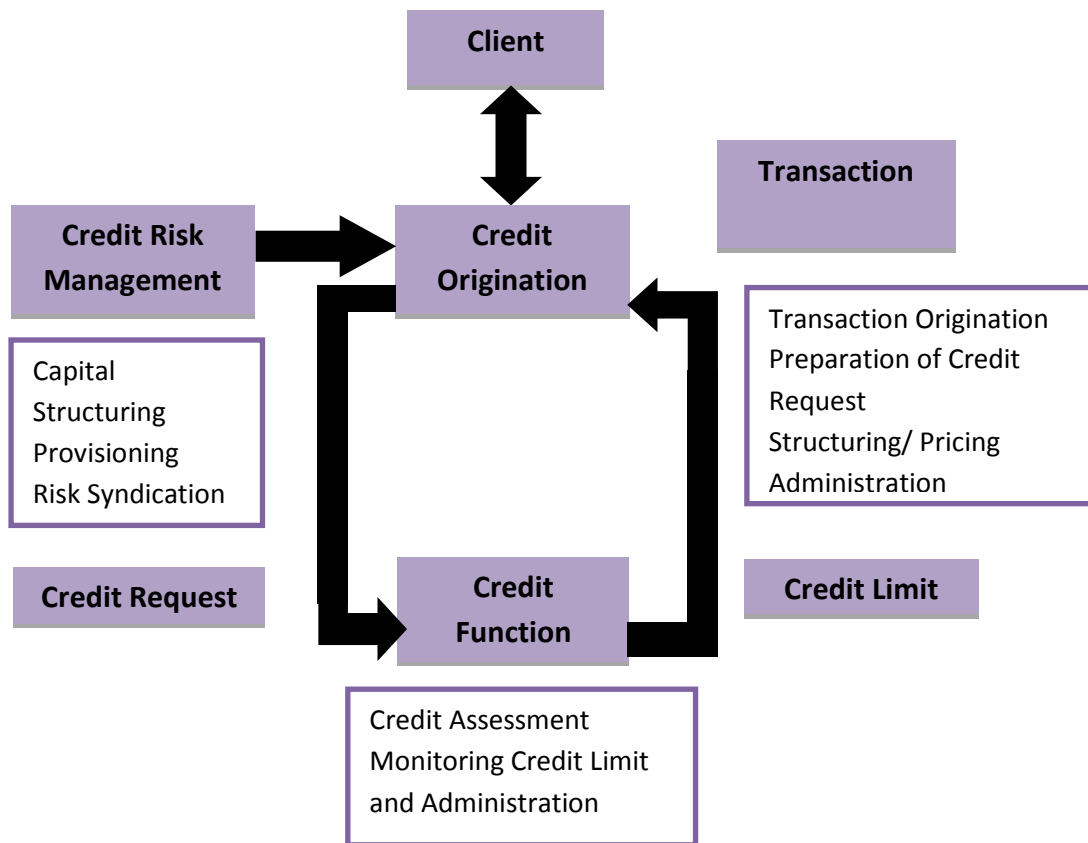

**Figure 4.2:** The credit risk management process

Source: Adapted from Colquitt, 2007:7

Credit origination or loan decision process relate to ex-ante credit risk management. This stage involves the transaction’s origination between borrower and lender. Credit requests are prepared and presented for approval. According to Kundid and Ercegovac, (2011), the purpose of this process is to avoid anti-selection of borrowers. The credit function involves credit assessment, monitoring credit limits and administration of the credit contracts to avoid moral hazard of clients. In so doing, the credit worthiness of lenders is evaluated.

Credit risk management also includes credit pricing and selection of clients and their investments, taking cognisance of the clients’ credit capacity and the bank’s attitude towards risks. Although credit risk can be alleviated in a variety of ways, one of the strategies for banks to cope and reduce portfolio credit risk in financial markets is credit rationing. According to Young (2006), credit risk can be mitigated through risk reduction, risk transfer and risk retention. From the analysis above, it can be deduced that credit rationing is a type of risk mitigation which consists of aborting or

reducing lending which is not caused by lack of funds. It therefore seems that credit rationing is an integral element of credit risk management in financial institutions. The next section deals with credit rationing associated with SME financing.

#### **4.3.1 Credit rationing and SME financing**

Various credit risk management approaches are utilized when extending credit to SME clients, depending on the volume of transactions and facility or loan size. Gitman (2009) defines credit standards as the minimum requirements for extending credit to a customer. Credit standards are also known as credit policies or business rules. In an effort to increase shareholder value, a firm may decide to change credit standards. Relaxing credit standards will increase sales volumes and may result in an increase of bad debt. Tightening credit standards will decrease sales volumes and may result in a decrease in bad debt. The credit standard decision is dependent upon the effect on profit. If profit and shareholder value increase, credit standards may be relaxed accordingly (Gitman, 2009).

Commercial banks tend to ascribe high risk to small businesses and are therefore reluctant to extend credit to them. Banks follow certain principles in evaluating credit applications and making credit decisions. The purpose of any credit assessment or analysis is the measurement of credit risk. Brierley (2001) argues that the willingness of financial institutions to provide finance to SMEs depends ultimately on the risk-reward relationship. This implies the extent to which such investments are likely to provide returns proportionate to the risk involved.

Due to their small size and intrinsic exposure to market fluctuations, the failure rates of small firms are relatively high in South Africa (Fatoki, 2012). The majority of SMEs is still in their infancy and therefore lacks financial history and a track-record of profitable projects. In addition, these SMEs are characterized by organisational and administrative deficiencies, low quality management and a lack of appropriate accounting systems (Fatoki and Aregbeshola, 2013) which may compromise the accessibility and reliability of information from SMEs regarding their repayment capacity (Green, 2003). The relative labour-intensity of the SMEs implies a high debt-to-asset ratio if loans are made. Lack of sufficient and adequate collateral further limits the amount of finance that banks are willing to grant to SMEs. Collateral thus acts as a screening device and reduces the risk of lending for commercial

banks. This is exacerbated by inadequate legal frameworks which make the enforcement of contracts difficult for financial institutions.

The difficulties faced by SMEs in accessing finance are attributed to their perceived higher risk profile. Lending institutions regard SMEs as risky enterprises for a number of reasons, which include the following:

- SMEs face a more uncertain competitive environment than larger firms. In other words, small firms experience more variable rates of return and higher rates of failure. Therefore lenders are left with no option but to ration the credit to SMEs who have little or no credit history.
- SMEs are usually less equipped, in terms of both human and financial resources, to withstand economic pressures such as the recent global credit crunch (Smit and Fatoki, 2012).
- There is the problem of inadequate accounting systems, which undermines the accessibility and reliability of information concerning profitability and repayment capacity.
- SMEs operate in volatile environments in the developing and emerging markets. For example, crime and labour unrests in South Africa have a negative impact on the security of transactions.
- There is also a greater risk that lenders will not get paid or that assets are not properly registered. SMEs may therefore not be paid in time for the products and services they render to the government through tender contracts (SEDA, 2008).
- SMEs are geographically unevenly distributed in South Africa, making it costly for banks to reach their clients. The share of people living in towns and cities (40% in Africa) is far less than in developed regions like Europe (80%). In South Africa, SMEs are scattered throughout the country, making it costly for banks to penetrate consumers without a transaction account (the unbanked) and those without access to incremental credit (the under banked).
- With less data available and an inherently higher risk than consumer lending, the operational cost generated by determining whether to accept an SME's credit application or not can often be higher than the potential return, and it is thus not uncommon to find that many banks do not encourage lower value

SME lending because the time and effort is not worth the revenue received (Gildert, 2009).

Demand for credit continues to come from businesses where the assessment of risk is difficult using traditional lending methods. Such businesses include unproven start-ups, unregistered small businesses, sole traders and partnerships that do not file any accounts other than for tax purposes. Despite the challenges discussed above, banks have to adopt risk management systems that take into cognizance the changing technological and economic environments. The next section reviews the risk management systems that banks have adopted in other parts of the world so as to overcome the challenges discussed in section 4.5.1

#### **4.3.2 Risk Management Systems**

As they learn to deal with SMEs, banks are reorganizing their credit risk management systems. De la Torre et al (2008) have observed that in most large banks, with the exception of credit scoring, credit risk management is not automated. As such it involves a credit risk analyst. In essence, risk management is a function that is organizationally separated from sales and is primarily done at the head office (De la Torre et al., 2008:30). The risk management department is therefore given independence and strong approval and rejection powers (De la Torre et al., 2008). However, the risk analysts and managers are expected to maintain independence and work cooperatively with those who sell products and initiate loans. In countries where business models are more advanced, there are SME account managers who are trained by risk analysts to raise their risk awareness. In so doing, the credit approval process is simplified and the loan application has a higher probability of being approved by risk analysts.

Evidence from Banco Ciudad de Buenos Aires (BCBA), one of the top three public financial institutions in Argentina indicate that large banks use well developed screening tools to filter out good debtors from the applicant pool (Klinger, Castro, Szenkman & Khwaja, 2013). These screening tools are differentiated by firm or loan size. According to de la Torre et al., (2008), the size threshold for the applicability of a given tool is typically determined by the effectiveness of the tool itself, as gauged by repeated experience. Therefore, automatic scoring models are usually applied to SMEs in need of small loans. However, the scoring technique does apply to large

loans, and hence there is need to use standardized rating tools for such loans. Tools such as qualitative and quantitative information are typically developed by adapting to the SME business rating methods applied to large organisations. According to de la Torre (2012:31), SME ratings do not lead to automatic approval of loans, but they rather provide a basis for the risk analyst to evaluate loans and decide on their approval. After the approval, the loans are continuously monitored by the bank, and an early warning system, with prompts to anticipate and detect potential problems, is put in place (de la Torre et al., 2008).

De la Torre et al., (2010) make a general statement that some banks in Chile and Argentina have embarked on medium-term plans to link screening tools to the banks' provision policies (for expected losses) and capital policies (for unexpected losses). Perfecting systems and procedures to generate risk-adjusted pricing unit cost-accounting per product or service line are also being developed. Other plans include greater use of stress testing, quantitative analysis, and improved estimates of loss given default and post-default recovery costs. Despite these plans, in the short-term, banks cope with difficulties in lending to SMEs by hedging risk, using instruments like short-term loans, document discounting and collateral (Chironga et al., 2012).

The credit risk management processes to serve SMEs discussed in section 4.5 can better be pursued by large commercial banks as they can better capture economies of scale and move beyond reliance on relationship banking (de la Torre et al., 2010). Commercial banks also have an extensive branch network that allows them to develop low-cost approaches to give SMEs a closer, tailored service without moving into costly, full-fledge relationship lending. In addition to this, commercial banks are well positioned to get information about valued SMEs with which large organisations work through outsourcing or supply connections. Due to their size and their presence in many different markets, commercial banks are better able to diversify away the distinctive risks of SME lending (De la Torre, 2008). Also commercial banks probably have better ways to assess the value of collateral, better recovery units and easier ways to execute the collateral.

In most developing countries, SMEs rarely possess the information required for a traditional credit scoring model – a credit rating, financial statements or collateral. According to Chironga et al., (2012), banks must therefore think beyond the standard



risk models to design simple data and information technology-enabled approaches to overcome the problem of information asymmetry. Some of the innovative strategies that banks have embarked on are reviewed in the ensuing section.

#### **4.4 INNOVATIVE STRATEGIES**

The banking industry is currently undergoing changes in response to swift changing customer behaviour, technological and regulatory realities (Chironga et al., 2012). Thus banks have to keep pace with changes in technology such as internet and cell phone banking, as more and more SME clients have access to mobile phones and laptops. For example, in Kenya 60% of the micro, small and medium enterprises (MSMEs) use M-Pesa, a mobile phone-based product, offering clients, payments and deposits or savings functionality (Chironga et al., 2012). The physical infrastructure is minimal, with account opening, cash transactions and customer support facilitated by more than 28000 merchants acting as agents.

According to Chironga et al., (2012), a significant number of MSMEs with traditional bank accounts in Kenya and Tanzania prefer M-Pesa for flexible, acceptable, safe and reliable transactions. It is believed that with new technology, banks are most likely to pursue channel innovation in order to reach SMEs even in remote rural areas. Thus, the internet is most likely to reduce operating costs and the turnaround times (of 1 to 4 days) for the processing of loan applications. The cost of risk for banks can be drastically reduced by creating products anchored in lean, automated processes. For example, according to Chironga et al., (2012), a large African Bank made savings of around \$15 million by reducing its application form from twenty to two pages.

At the same time, banks can issue more products other than loans to their SME clients such as the cheque account, foreign exchange, savings and the use of derivative instruments such as swaps and options. Lending institutions should strike a balance between maximizing profits and adding value to SME clients at affordable prices. Therefore banks must meet their clients' needs at the lowest possible costs in terms of distribution and products. Distribution can be achieved through the provision of low cost branches and the extensive use of correspondent banking. With correspondent banking, banks use retailers to expand their distribution reach. For

example, in Colombia one bank has 700 branches and 900 correspondent outlets (Stephanou and Rodriguez, 2008).

Another strategy being used by banks to screen SME clients is the psychometric testing. According to Chironga et al., (2012), psychometric testing uses test scores to separate good clients from bad ones, and are capable of lowering default rates by 25-40%. This is a self-administered test done in thirty to forty minutes and measures attributes such as entrepreneur's psychological profile, ethics and integrity, intelligence and business skills. According to the Chironga et al., (2012), the cost of assessment is 45% less than the traditional credit assessment measures. The fact that psychometric testing is computerized, simple and cheap makes it ideal for use by banks to evaluate the creditworthiness of SMEs which lack traditional credit scoring inputs such as pay slips and credit history which are conditional requirements for loan approval. Psychometric testing has been successfully used by banks in Chile and Argentina (Klinger et al, 2013), while in South Africa Standard Bank has successfully used it in a pilot study (Botha, 2012).

Banks elsewhere in the world use approaches which combine quantitative and qualitative assessment instruments such as the Qualitative Credit Assessment (QCA) tool by McKinsey (Chironga et al., 2012). The QCA is a 15-25 question assessment tool for SME clients that can be completed in less than an hour. Areas covered by the QCA include SME competitiveness (identifying the strength and integrity of the entrepreneur), SME company management (ownership structure, and relationship with the bank), and the way the company operates (including relationship with its suppliers and customers). Each of the questions is then aggregated to provide a score, with the weight of each question in the score being determined by the question's predictive power. The QCA has been successfully used by more than 20 countries in the emerging markets, including South Africa (Chironga, et al., 2012). The strength of QCA questionnaires can be tailored to reflect factors relevant to a bank's country and target client segments.

Another approach is for banks to advance unsecured credit to SMEs in an effort to do away with collateral altogether. Banks can use insurance of loans instead of collateral and if priced correctly, can deliver exciting returns from loans which can improve their profit. In South Africa, unsecured credit is gaining popularity amongst

all the leading commercial banks (National Credit Regulator, 2011). Instead of relying on financial statements, other banks now rely on the lender's estimate of cash flow through observation of the business or analysis of payments into a transactional account. However, credit scoring is only one element of the credit risk management process. Therefore, banks must review all parts of the credit process which include credit origination, underwriting, monitoring and collections as shown in Figure 4.3.



**Figure 4.3:** Proposed credit risk management process for SMEs

Adapted from Chironga et al., (2012)

Details of the credit management process have been discussed in section 4.5 but a few additional aspects are noted here. In the origination stage, banks are challenged to limit or eliminate client fraud by knowing their clients well. This can be achieved through regular visits to the client's business premises. In underwriting, bank staff is encouraged to take accountability of both the revenue and risk associated with bank lending to SMEs and "lend as if it is their money" (Chironga et al, 2012). It is suggested that the final approval for a loan application should be made by the bank manager, with the aid of credit assessment tools. In such instances the managers will be able to take into account personal circumstances which cannot be considered by the credit assessment tools. With credit monitoring banks are encouraged to monitor credit risk on a continuous basis and not leave it until late. Finally the credit collection section is advised to maximize the net present value by recovering partial payments now than wait for full repayment after lengthy court battles. Therefore a lot more other factors have to be taken into consideration for the credit risk management process to be effective when lending to SMEs.

By reviewing all parts of the credit process, the problems of information asymmetry and lack of collateral are taken care of, thereby allowing more SMEs which are considered to be informationally opaque to access credit. If more SMEs are able to

access credit, there will be sustainable growth in the SME sector while at the same time banks improve their profitability. However, to complement these efforts, banks need to engage themselves in improving the financial literacy of their SME clients. Such issues are discussed in the following paragraph.

From the lender's perspective, poor financial literacy increases transaction costs, notably the investment in the time required to explain products, services, interest rates and other issues to bank clients. In a survey of the commercial banks in emerging markets, including South Africa, Chironga et al., (2012) indicate that poor business plans (a consequence of poor financial literacy) is the number one reason why banks decline credit applications for SMEs. In addition to that, SMEs often have limited knowledge of bookkeeping, supply chain management, sourcing and pricing. Therefore banks need to empower their clients by developing their clients' financial literacy and business skills. Empowering clients with financial literacy and business skills helps existing SME clients survive where they might not have done so, and new clients thrive, thereby increasing the bank's profits.

From the analysis above, it has been observed that banks need to keep pace with the changing technology such as internet and cell phone banking through the pursuit of channel innovation. Transaction costs can be minimized by reducing the turnaround time for processing applications, and extensive coverage of banking services through correspondent banking. Other strategies that have been successfully employed in other parts of the world include psychometric testing, Qualitative Credit Assessment and the advancement of unsecured lending. If traditional lending strategies do not work for SME financing, then banks need to develop innovative techniques that will capture this supposedly potential market

#### **4.5 CHAPTER SUMMARY**

The chapter has reviewed the substantial literature pertaining to the issue of credit rationing and credit risk management. It has been shown that adverse selection, adverse incentive and moral hazards derive directly from the imperfect information present in the loan markets. Consequently, lenders (banks) are unable to distinguish between borrowers, which may threaten accurate risk-evaluation of credit applicants and projects. This in turn may adversely affect the probability of loan repayment and the profits of the bank. To mitigate these problems, lenders employ a variety of

mechanisms which, although alleviate their magnitude, do not eliminate them completely. This may lead to the rationing of credit for SME clients by the banks.

The chapter also examined the impact of information asymmetry on bank lending to SMEs and the role played by relationship lending and collateral in determining the availability, quantity and cost of credit. It was established that relationship lending can help lenders close the information gap while collateral ensured the banks of the lender's commitment to repay the loan. Both these attributes reduce the risk of default by SME clients.

Section 4.5, presented a brief review of the credit risk and credit risk management associated with bank lending to SMEs. It was established that credit risk is the most important of the risks experienced by banks when lending to SMEs and hence credit rationing remains an integral element of credit risk management. The chapter also discussed the new strategies and innovations being used in SME bank financing elsewhere in the world. It was established that SMEs in developing economies do not possess the information required for a traditional credit scoring assessment, hence the constrained access to bank credit. Therefore, banks are urged to make use of innovative risk management strategies such as the use of internet and cell phone banking, correspondent banking, cross-selling products, psychometric testing, Qualitative Credit Assessment and the advancement of unsecured loans. Furthermore, banks are encouraged to empower their clients by developing their financial literacy and skills to help them survive the harsh economic conditions.

The review of the credit literature provides the study with background knowledge on the concept of credit rationing. It further provides detailed knowledge on information asymmetry, relationship lending and the role of collateral, and its impact on credit on the supply of bank credit to SMEs. This chapter therefore serves as a solid foundation for the empirical chapters on SME financing. The next chapter presents an in-depth discussion of the research design and methodology that is used in answering the stated research questions in order to achieve the research objectives that are identified in chapter one.

## **CHAPTER 5**

### **RESEARCH METHODOLOGY**

#### **5.1 INTRODUCTION**

This chapter deals with the research methodology which is crucial, as it underpins the analysis of the literature. In the light of this significance, this chapter presents the research design for this study and the implementation thereof. Given that research design and methodology direct a researcher in planning and implementing a study in a way that is most likely to achieve the intended outcome and to provide the blueprint for conducting the research, this chapter is aimed at achieving these objectives. In support of the above McGivern (2006) states that research is about enquiry, and systematic investigation to find relevant solutions to problems.

In addition, this chapter also deals with the research design, the research methods used in this study and, the statistical techniques used for the analysis of the data. The research process will be dealt with in the ensuing section as a starting point for this chapter.

#### **5.2 THE RESEARCH PROCESS**

In order to give direction for this study, the research process “onion” of Saunders, Thornhill and Lewis (2012) was adopted. This research onion illustrates the paradigms, strategies and methods followed by the researcher during the research process. The concept of the research ‘onion’ provides a summary of the important issues that need to be taken into consideration and reviewed before undertaking any research. The different layers of the ‘onion’ serve as a platform for the following considerations: the philosophical positioning of the researcher; the research approach adopted; appropriate research strategies; the research time lines that are under review; and the data collection techniques employed by the researcher. Figure 5.1 below shows the research onion which was used as a guideline and justification for the chosen research designs and strategies used in this study.

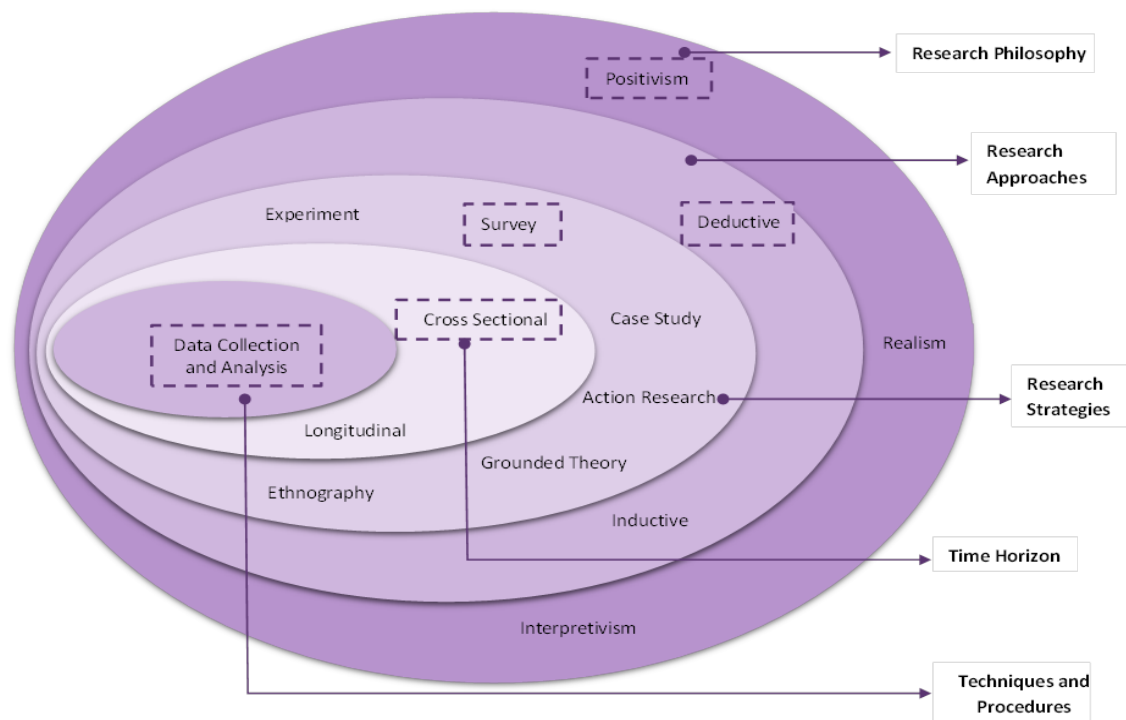

**Figure 5.1:** The research ‘onion’ (Saunders et al., 2012:128)

The next sections will deal with the components of the research onion.

### 5.2.1 Research Philosophy

According to Saunders et al. (2012), the first important layer of the research onion deals with the research philosophy. Research is defined as the systematic collection and interpretation of information with a clear purpose to identify issues/concepts (Saunders et al. 2012). It is a careful and systematic means of solving problems. According to Fellows and Liu (2008) research is defined as a “voyage of discovery” with the hope of discovering the truth and constructing reality. Research is founded on philosophical assumptions, which are related to the researcher’s view or perception of what reality is. According to Easterby-Smith, Thorpe and Lowe (2008), such philosophical assumptions can be understood in terms of epistemology and ontology.

Saunders et al. (2012) define epistemology as a branch of philosophy that studies the nature of knowledge that concerns itself with the understanding of how people have come to know what they claim to know. Based on such a perspective, some of the questions that emerge relate to what constitutes meaningful evidence, as well as to what process gives rise to knowledge. On the other hand, ontology is concerned

with the nature of reality or as Neuman (2011) puts it, ontology is the science of being and existence. In effect, therefore, ontology is the researcher's perception on the nature of the real world. Ontological questions relate to issues such as the nature of reality and to whether reality can exist prior to being discovered.

In keeping with the above philosophical assumptions, research in the scope of natural and social sciences has assumed different perspectives. Consequently, two different streams of research, with different methodological underpinnings, have emerged, namely positivism and interpretivism, which are discussed below.

### **5.2.2 Positivism and interpretivism research paradigms**

A research paradigm is a comprehensive belief system that guides research and practice in the field. Collis and Hussey (2009) define a research paradigm as a system in terms of which people view events. These research paradigms provide a theoretical framework for choosing an appropriate research methodology. The positivism research paradigm is variously referred to as the 'normative' and it is 'quantitative' in nature, while the interpretivism paradigm is often referred to as 'social constructivism' with a 'qualitative' orientation. According to Gill and Johnson (2010), positivist scholars argue that the world is concrete and real, and that a separation is necessary between the researcher and the research object in order to prevent the former's subjective feelings from affecting the research process, which might otherwise, lead to biases in the study. Positivists believe that observations and measurements constitute the core of all scientific undertakings.

Easterby-Smith et al. (2003) posit that interpretivists use approaches epitomised by the rigorous application of techniques in a carefully structured design to establish high authenticity and credibility. In support of such an argument, Fellows and Liu (2008) contend that truth and reality are socially constructed and cannot, therefore, exist independently. Interpretivists, therefore, maintain that the researcher's key role in the research process is to gain a general overview of the context of the topic under investigation. As a result, qualitative methods of analysis and their explanation highly favour interpretivist research.

Advocates of positivism and interpretivism have advanced reasons for claiming the supremacy of one school which they advocate over the other. Positivists, for



instance, posit that qualitative data does not necessarily exist in exclusivity, and that all data can be quantified by means of allocating figures or codes (Babbie, 2011). Contrary to this, the interpretivists argue that all data are basically qualitative, with numbers merely being attached to meanings in quantitative analysis. As the debate rages on, various research methods characterising both the positivist and interpretivist approaches have emerged (see Tables 5.1 and 5.2 below).

**Table 5.1:** Various research approaches in terms of the positivist paradigm

<b>Research Approach</b>	<b>Questions</b>	<b>Main features</b>
Experiments (Laboratory)	How, why	Intensive study; precise relationship; Quantitative variables
Experiments (field)	How, why	Real-life situation experiments
Archival analysis	Who, what, where, how many	Quantitative and qualitative analysis of records to describe incidences
Forecasting future research	What, how much	Insights into likely future events
Simulation, game role playing	What, how	Simulating the behaviour of a system by generating and introducing random variables
Surveys	Who, what, where, how many, how much	Questionnaires, interviews, observations used to obtain data on practices or situations

Source: Adapted from Saunders et al., (2012)

**Table 5.2:** Various research approaches in terms of the interpretivism paradigm

<b>Research Approach</b>	<b>Questions</b>	<b>Main features</b>
Case study	How, why	Explanatory; exploratory; descriptive
Archival analysis	Who, what, where, how many	Quantitative and qualitative analysis of records to describe incidences
History	How, why	Explanatory studies relating related to happenings over time
Subjective argumentative	What	Creative; free flowing; unstructured
Action research	What to do, how, why	Obtaining results and benefits for practical value
Grounded theory	What	Structured approach to forming theory grounded in data
Descriptive interpretive	What, how, why	Based on the philosophy that phenomena are the essence of experience; development of cumulative knowledge

Source: Adapted from Saunders et al., (2012)

The current study applies the positivist paradigm, based on the understanding that researching knowledge management practices and organisational learning is deeply rooted in social context. This thesis is not only interested in knowledge construction, but also aims to contribute to a better understanding of customer behaviour towards the supply of bank credit by taking into account the positivist paradigm as appropriate. This study seeks to understand the phenomenon of value creation for SMEs and banks, by understanding the drivers and barriers towards access to finance. Thus, the study investigates certain elements that have an objective, external reality and also tries to question the prevalent social constructions of reality.

### **5.3 RESEARCH APPROACH**

According to Saunders et al (2012), the second important layer of the 'onion' deals with the approach between deduction and induction. Deduction is a research approach which involves the testing of a theoretical proposition by using a research strategy designed to perform this test while induction is a research approach which involves the development of the theory as a result of analysing data already collected (Burney, 2008). Since the objective of this research is to explore the influence of access to bank finance variables mentioned in the literature review on credit supply, a deduction approach was used. The next paragraph discusses the research design adopted for this study.

### **5.4 RESEARCH DESIGN AND METHODOLOGY**

#### **5.4.1 Research Design**

There are different research designs, for example exploratory, explanatory and descriptive designs. For the purposes of this study the researcher utilised the descriptive research design to achieve the stated objectives. According to Saunders et al., (2012), a descriptive study is a research designed to produce an accurate representation of persons, events or situations and therefore considered appropriate for this study as a lot is known around the subject and hence there is no need for exploratory designs.

In conducting the research study, a quantitative research method was used. Babbie, (2013) defines quantitative research as the methods that primarily seek to express information numerically, in terms of quantities or measurements. Quantitative

research method derives empirical generalisations which can be used to determine future courses of action, or which solve a particular research problem. Quantitative research is usually used in descriptive studies and subjects the results to statistical tests in order to quantify data and generalise the results obtained from a representative sample to the target population (Hollensen, 2003; Tustin, Ligthelm, Martins & van Wyk, 2005). The research format for this study follows a descriptive approach as it provides a useful analysis of the research variables based on the data to be collected as well as answer questions on 'who', 'what', 'where' and 'how'.

Quantitative data was collected by distributing a questionnaire amongst bank officials in the four leading commercial banks and SME owners/managers in the Gauteng province. Survey research is undertaken to measure the characteristics of different groups, or their attitude towards, or perceptions of, a certain phenomenon. The questions in the research instruments were based on the theory from the literature for consistency and hence provided both content and construct validity.

#### **5.4.2 Time Dimension**

The time attribute of a research study plays an important part in the design and execution of a research study (Babbie, 2013). This study collected data from different places which are widely separated by big geographical distances. Many constraints were needed to put into consideration especially in terms of time and finances. After putting these constraints into consideration, cross-sectional study was opted for. In this case data was gathered just once over a period of six months.

In this study, the cross-sectional dimensions were deemed the most appropriate and suitable as the study involved a large-scale survey focusing on banks and SMEs at a specific point in time. The next section addresses issues relating to the innermost layer of the 'onion' which deal with the research methods used in the study.

#### **5.4.3 Population, sample and sampling method**

##### **Population of the study**

A target population is the entire group under study as specified by the research (Bradley, 2007). For the purposes of this research, the target population comprised of SME owners/managers and banks. The banks included in the survey, were commercial banks that have a working relationship with SMEs based in the Gauteng

province of South Africa. The reason for this selection is that the South African banking industry is dominated by four major players, namely Standard Bank of South Africa (SBSA), the Amalgamated Bank of South Africa (ABSA), First Rand Bank (FNB) and Nedbank - all of which account for almost 85 percent of the industry's total assets (Akinboade and Kinfack, 2014) and are considered to be the most sophisticated banking institutions in the South African industry. With such a strong banking sector, it is of interest for this study to determine why access to bank credit continues to be a challenge to SMEs in South Africa.

In addition to the identified banks, SMEs were also considered in the target population. Statistics South Africa (StatsSA, 2013) documented the total number of SMEs in South Africa to be approximately 1.8 million of which 33 to 40 percent of the SMEs are in Gauteng province alone (StatsSA, 2013). According to the Department of Trade and Industry (DTI 2011:156), the number of SMEs in Gauteng is estimated to be approximately 10,000. Johannesburg alone accommodates 70% of the SMEs in the province. This study focuses on the SMEs registered with the DTI and commercial banks in Johannesburg and Tshwane cities, the two largest cities in the province.

It is noteworthy that no existing database for the number of SMEs was in place at the time of the survey, a situation consistent with the observation of Babbie and Mouton (2011) that, unlike in developed countries, researchers in developing countries struggle to acquire data on SMEs either because extensive information is not available, or when it is available, it is erratic. The next section describes the sampling technique.

- **Sample and sampling method**

Sampling is the process of choosing units (for instance organisations or people) from a specific population of interest so that, by studying the sample, we can generalise the results to the target population from which they were chosen (Neuman 2011). Sampling falls into two main categories: probability and non-probability sampling. Probability sampling is, organised in terms of simple random, complex random, systematic, cluster and stratified sampling (Leedy and Omrod, 2010:205). Non-probability sampling, in contrast, constitutes convenient sampling, purposive sampling and snow ball sampling.

In ensuring that the survey sampling was the representative of the population, the researcher used stratified random sampling to stratify the population into commercial banks and SMEs. In stratified random sampling, the population was divided into a number of strata which were mutually exclusive (Kolb, 2008) and a random sample was obtained from each stratum (Tustin, Lighthelm, Martins & Van Wyk, 2005). In this case the characteristics of the banks and SMEs are different hence stratification. The four strata in the selection of the sample of bank branches were, ABSA Bank, First national Bank, Nedbank and Standard Bank. Within these four strata, systematic random sampling was used to select 100 bank branches in each stratum. Also, from the list provided by the associations, stratified random sampling frames of SMEs were constructed. According to Strydom (2005), "in systematic sampling, the first case is selected randomly and all subsequent cases are selected according to a particular interval". The first bank branch was selected randomly from a list of branches in each stratum and thereafter every 10<sup>th</sup> branch until 100 branches in each stratum were selected. The same process was applied for the SMEs and The reason for using systematic sampling over simple random sampling was that it is often easier to draw a systematic sample and execute without mistakes (Timmons, 2007).

In total four hundred bank branches in the Gauteng province were selected. Based on this selection, after distributing the questionnaires, a response rate of 51% was obtained.

- **Sample size**

The sample size is significant to consider in the research. According to Quinlan (2011), the size of a sample in any research relies on the type of study being carried out, although practical restrictions might have an influence. Hence, by involving specified inclusion criteria, the sample becomes homogeneous, which means that there is not much difference within the sample, permitting a smaller sample size (Kaplan and Saccuzzo, 2008). According to Bradley (2007:185), the best sample size depends on the following factors:

- Required precision of the study
- Budget, resources and time available
- Nature and size of the population under study

- Significance of the results

The following three techniques were applied in determining the sample size for the current study:

- The first technique is based on Krejcie and Morgan's (1970) table, as reproduced by Sekaran (2003:294). According to the table, the corresponding sample for the SME population of approximately 10000 (which is the population for the current study) and 500 bank branches in Gauteng is given as approximately 370 and 217 respondents respectively.
- The second technique involved computing the sample size using the formula provided by Yamane (1967), which is depicted as follows:

$$n = \frac{N}{1 + N(e)^2}$$

Where:

n = the sample

N = the population of the study

e = the level of significance (set at 0.05 for this study)

To arrive at the sample size, the above formula was used by substituting with known quantities as follows:

$$n = \frac{N}{1 + Ne^2} = 10000/(1+10000 \times 0.05^2) = 384 \text{ SMEs}$$

For the banks, the questionnaires were distributed to bank branches of the four big banks.

$$n = \frac{N}{1 + Ne^2} = 500/(1+500 \times 0.05^2) = 222 \text{ bank branches.}$$

A sample size of 384 SMEs and 222 bank branches was generated using the above formula; given a 95% confidence level is maintained.

- The third technique that is applied in this study is aimed at satisfying the conditions of factor analysis. The technique followed Hair, Black, Babin, Anderson and Tatham's (2014) recommendations. According to these authors, it is essential to ensure that for those observations which are conducted in a study must be at least five times as many as the number of variables analysed, which implies attaining a ratio of 5:1. In the current study, 26 items were used in the bank analysis in terms of credit supply and 50 items were used in the SME analysis. The corresponding number of observations, on the basis of 5:1 ratio is therefore estimated to be 130 observations (26 x 5) for banks and 250 observations (50 x 5) for SMEs. The application of such a method requires that the suitable samples be constituted of 130 and 250 respondents respectively.

The recommended samples were decided upon by considering all three scientific techniques, namely those of Sekaran (2003:294) = 370 and 217; Yamane (1967) = 384 and 222; and Hair et al. (2006) = 250 SMEs and 130 bank branches. In this study, 500 questionnaires were distributed to SMEs and 400 to the banks, thus exceeding the number that is recommended by the techniques adopted. The number of responses ultimately generated for the analysis amounted to 262 for SMEs and 188 for banks representing a response rate of 52% and 51% respectively. After the target population had been identified, the sample was finalised and was ready for data collection.

#### **5.4.4 Data collection instrument**

The research adopted a self-administered questionnaire on a five-point Likert scale to acquire responses from "strongly disagree" to "strongly agree". This was designed based on selected characteristics as per the literature. According to Zikmund (2003), the self-administered questionnaire has advantages such as flexibility, lower costs, respondent convenience, time saving, standardised question design and well-structured questions.

The questionnaire was designed based on the constructs and variables selected from the literature study in chapters two to four. Accordingly, two self-administered structured questionnaires with closed-ended questions were compiled; one for the banks and the other for the SME owners/managers. A five-point Likert scale

questionnaire survey was used to generate quantitative data and was designed around opinion statements as a means of exploring the respondents' perception on a wide range of cause and effect relationships on SMEs access to finance. The questionnaire consisted of four sections namely demographic information, financial information, credit risk management and obstacles to SME financing.

#### **5.4.5 The pretesting process**

After the questionnaire had been developed, a pilot test was executed by distributing the questionnaire to 10 respondents who were not part of the main study, to see if it was collecting the data that it was intended to collect, and to see if respondents understood the content. According to Quinlan (2011) and Babbie (2011) researchers are advised to develop some procedures for survey pretesting. This research, consistent with this advice, adopted a multi-stage testing process that integrated various techniques. The process began after the survey was considered "ready" by its developers. This stage consisted of a review by knowledgeable colleagues and analysts to ensure question completeness, efficiency, relevance, and format appropriateness. This included an assessment of the cognitive and motivational qualities of both questionnaires. This process helped to ensure, easy readability, consisting of interpretation, consistency, logical sequencing and overall positive impression from the look and feel of the survey. The second stage consisted of a small pilot study (discussed below) that incorporates the major procedures proposed for the main study. This helped to refine the wording of the questions and test the clarity of both questionnaires.

The main points considered during the pilot process are the following:

- Bias in the wording of the questions
- Requesting inappropriate demographic data
- Overlapping question scales or selection options
- Inaccurate or missing instructions
- Technical vocabulary with no definitions

In discussing the pilot surveys, Quinlan (2011) emphasizes that pre-testing begins with question development because every question and every scale used in the survey must be tested and re-tested as improvements are made. In addition, the



question lay-out, instructions to respondents, the answer categories and even the question numbering system should be tested, along with the sampling and data analysis techniques.

Accordingly, a pilot study was conducted to determine the feasibility of the study to: test the reliability and validity of the instrument as well as the trustworthiness of participants for data collection in the main study; address any problems prior to the main study; and check the time required for the completion of the questionnaire. The pilot study included 37 questionnaires collected from SME owner-managers; and 11 questionnaires collected from bank officials. Respondents were asked to express their opinion about the clarity of the questionnaire and to make suggestions about how the instrument could be made easier to understand. After collating the input from all the respondents, the statistician and literature sources, the questionnaires were finalised for data collection.

#### **5.4.6 Data collection procedure**

Babbie (2011) states that data collection methods are the actual ways of collecting data for a study, conducting an experiment or focusing on the analysis of statistics that are already created by others. Close-ended questions were used to generate a response pattern that was analysed using Statistical Package for Social Sciences (SPSS) and Analysis of Moment Structures (AMOS) version 23. Permission was sought from the university to conduct this study before any attempt to collect data from the participants was initiated.

Questionnaires were used as a data collection instrument in this study. Creswell (2014) considers questionnaires as the most viable research method as they are cost-effective and they can be administered within a short period of time without compromising the validity and reliability of the research. By using questionnaires, it was easy to access respondents and capture data in a more precise and effective way.

Before administering the questionnaires, a pilot study was conducted, comprising the target population, namely bank staff working with SME loan applications, SME unit managers and the SME owner/managers. The approval from the banks to conduct

this research was gained, subject to a proviso that the bank would have the right to receive an executive summary of the key findings of this research. According to Brace (2008), pilot testing can be successful in identifying the needed changes if as few as ten individuals are willing to complete it and provide suggestions to improve clarity and format. This exercise was done to ensure that the research questions could be answered by all groups with ease. After the pilot study, the questionnaire was reviewed and some necessary amendments were done. Furthermore, the researcher had an opportunity to assess validity of the questions and the extent of reliability of the data.

Four hundred questionnaires were distributed to the banks. However, 202 completed questionnaires were returned, rendering a response rate of 51%, and of these, 181 responses were useable. Twenty-one responses were thus eliminated from this sample due to incompleteness of the questionnaire or giving the same answers to all the questions. Although, collection of data from clients was carefully conducted, the incompleteness was caused, according to some participants, by their lack of time to complete all the focus units in the questionnaires. The SME questionnaire was distributed to 500 participants, of which 262 (52.4%) questionnaires were captured for analysis. Questionnaires were collected over a period of three months.

## **5.5. DATA ANALYSIS PROCEDURES**

The Statistical Package for the Social Sciences (SPSS) version 22 was used to analyse the data. All items that were not reliable were dropped from the instrument. The descriptive statistics in the form of frequencies, proportions and mean, were used to describe the variables. Composite variables were calculated using the averages and summary statistics to determine the patterns depicted by the variables. Correlation analysis was used to determine the relationship between the dimensions. The results of the exploratory factor analysis are used to create new variables and the factors are named. The new variables are then used in confirmatory factor analysis to determine how well the measured variables represent a small number of constructs (Hair, Black, Babin & Anderson, 2014). Structural equation modelling was then used to determine the statistical model that seeks to explain the relationship among the variables.

#### 5.5.5.1 *Correlational analysis*

In probability theory and statistics, correlation (often measured in terms of a correlation coefficient) indicates the strength and direction of a linear relationship between two random variables (Pallant, 2010). Correlation analysis was conducted among the variables to provide insight into possible relationships among variables. Because of the conventional dictum that correlation does not imply causation, these correlations cannot be validly used to infer causal relationship between the variables (Pallant, 2010). Pearson correlation coefficient was used to test the association between the variables and the chi-square test to establish the level of significance of the association. Having established the presence of correlation, regression analysis, was done to determine the influence of the predictor variables on the endogenous variables.

#### 5.5.5.2 *Regression analysis*

Regression analysis is a collective name for methods that can be used for the modelling and analysis of numerical data consisting of values of a dependent variable (also called a response variable or measurement) and one or more independent variables (also known as explanatory variables or predictors). The dependent variable in the regression equation is modelled as a function of the independent variables, corresponding parameters (constants) and an error term. Regression is used for hypothesis testing, and it is also referred to as modelling of causal relationships (Pallant, 2010). The use of regression analysis relies heavily on the underlying assumptions being satisfied. Multiple regression analysis was used to model the relationship between one continuous dependent variable (credit supply) and other continuous independent variables (transaction costs, lending technology, innovative strategies, creditworthiness, collateral, bank-SME relationship and risk management). A dependent variable is described as a measured variable that depends on the behaviour of an independent variable (Albright, Winston & Zappe, 2009). In this study the dependent variable for banks is credit supply and that for SMEs is access to finance. The independent variable is one that influences the dependent variable and can be controlled in an experiment (Albright et al, 2009).

The estimated model took the following form:

$$Y = \alpha + \beta_1TC + \beta_2C + \beta_3LTech + \beta_4CW + \beta_5IS + \beta_6BSMER + \beta_7RM + \varepsilon_1 \quad (1)$$

Where

Y = Credit supply

TC = transaction costs

C = collateral

LTech = lending technology

CW = Creditworthiness

IS = innovative strategies

BSMER = bank-SME relationship

RM = risk management

$\beta$  = Beta

$\varepsilon_1$  = error term and  $\alpha$  = constant

For the SME survey, the estimated regression model took the following form was used to estimate the access to finance model:

$$Y = \alpha + \beta_1CW + \beta_2C + \beta_3AI + \beta_4CR + \beta_5EB + \varepsilon_1 \quad (2)$$

Where

Y = Access to finance

CW = Creditworthiness

C = Collateral

AI = Information asymmetry

CR= Credit Rationing

EB = Electronic banking

$\varepsilon_1$  = error term and  $\alpha$  = constant

The following assumptions of regression analysis were used in the research:

- The error is assumed to be a random variable
- The independent variables are error-free and the predictors are independent
- The errors are uncorrelated, that is, the variance-covariance matrix of the errors is diagonal and each non-zero element is the variance of the error.
- The variance of the error is constant across observations (homoscedasticity)

When testing theoretical models, it is important to examine beta scores in order to determine the importance of each variable relative to changes in the dependent variable diversity. The above variables were significant in the regression model and structural equation modelling. Therefore, were regarded as the final equation for the model.

The researcher performed regression analysis to determine the strength of combined independent variables, in determining the magnitude of movement and direction of movement in the dependent variable (Pallant, 2010).

#### *5.5.5.3 Structural Equation Modelling*

Structural Equation Modelling (SEM) is used to determine the main factors influencing supply of credit to SMEs by banks in South Africa. SEM is used to estimate all coefficients in the model in order to evaluate the significance and strength of the relationships within the model (Su and Yang, 2010; Turyahebwa, Sunday, Ssekajugo, 2013). Thus, SEM specifies the causal relationships among the latent variables, describes the causal effects, and assigns the explained and unexplained variance (Lukman & Abdullah, 2011). Latent variables are the constructs or factors whose features are not seen or are unobservable but can only be measured by their respective indicators.

As discussed earlier, SEM's potential to do multiple regression analysis of factors among a single measured dependent variable and a group of measured independent variables (Hair et al. 2006) made it a suitable analysis for this study. Another factor that made SEM suitable for this study is the use of confirmatory factor analysis (CFA) that helps in evaluating the equivalence of the different data used in this study that were obtained. Hair et al. (2006) also recommends CFA for its ability to assess both the metric and scalar invariance. This measurement is crucial in the comparison of latent variables. The statistical tools used in this study to carry out this analysis are; IBM Statistical Package for Social Sciences (SPSS) Statistics version 23.0 together with SPSS Analysis of Moment Structures (AMOS) Version 23. The two tools help to build and validate the models with more accuracy than the standard multivariate statistics techniques.

There are a number of available fit indices, which are classified as absolute fit indices and incremental fit indices and they should be represented in standardised scientific research. Kline (2005) speaks strongly about which indices to include and advocates the use of the following absolute fit indices: Chi-Square test (and its degrees of freedom), the Root mean square error of approximation (RMSEA) and its associated confidence interval, goodness of fit (GFI) and the incremental fit index, Comparative fit index (CFI). These indices have been chosen over other indices as they have been found to be the most insensitive to sample size (Hooper, Coughlan, & Mullen, 2008). These fit indices are described below:

- **Model chi-square ( $\chi^2$ )**

The most fundamental absolute fit index is the chi-Square ( $\chi^2$ ) statistic. The chi-square value is the overall measure for evaluating overall model fit and assesses the magnitude of discrepancy between the sample and fitted covariance matrices (Coughlan, et al., 2008). A good model fit would provide an insignificant result at 0.05 thresholds and as the sample size increases so is the  $\chi^2$  value and it is also likely to be higher when the number of observed variables increases.

The implied null hypothesis is that the observed sample and SEM estimated covariance matrices are equal, suggesting that the model fits perfectly. When it is found that the p-value for the test is small (statistically significant), it indicates that the two covariance matrices are statistically different and hence signifies problems with fit (Anderson, Babin, Black & Hair, 2010). In SEM, we look for relatively small  $\chi^2$  and the corresponding large p-value to support the idea that a proposed theory fits reality; that is we seek a model, in which the Chi-Square test is not significant, as indicated by a p-value above 0.05. To minimise the impact of sample size, the normed chi-square ( $\chi^2 / df$ ) is used with the acceptable ratio for this statistic ranging from 5.0 to as low as 2.0.

- **Goodness-Of Fit Index (GFI)**

The GFI was an early attempt to produce a fit statistic that was less sensitive to sample size as an alternative to Chi-Square test. It calculates the proportion of variance that is accounted for by the estimated population covariance (Coughlan, et al., 2008). This statistic ranges from 0 to 1 with larger samples, increasing its value and traditionally the cut-off point of 0.9 has been recommended for the GFI. However, simulation studies have shown that when the factor loadings and sample sizes are low, a higher cut-off of point of 0.95 is more appropriate (Anderson, et al., 2010).

- **Root mean square error of approximation (RMSEA)**

The RMSEA tells us how well the model, with unknown but optimally chosen parameter estimates would fit the population's covariance matrix and in recent years it is regarded as one of the most informative indices (Coughlan et al., 2008). Recommendations for the RMSEA cut-off points have been reduced considerably over the years with the more recent one indicating that the value should be in the range of 0.05 to a stringent upper limit of 0.07 with values below 0.05 and close to zero showing the best fit. Anderson et al. (2010) also argue that the values between 0.03 and 0.08 present a good fit with 95% confidence.

- **Comparative Fit Index (CFI)**

The comparative fit index (CFI) is an incremental fit index that is a revised form of the normed fit index (NFI) which takes into account sample size that performs well even when sample size is small (Coughlan, et al. 2008). NFI assesses the model by comparing the chi-square value of the model to the chi-square of the null model. Coughlan et al. (2008) indicates that CFI assumes that all latent variables are uncorrelated (null/independence model and compares the sample covariance matrix with this null model). CFI values range from 0.0 and 1.0 with values closer to 1.0 indicating good fit and a value of  $CFI \geq 0.95$  is presently recognised as indicative of a good fit. The summary of the selected fit indices is shown in Table 5.5.

**Table 5.3:** Fit indices and their acceptable levels

Fit Index	Acceptable Threshold Levels	Interpretation
Chi-Square	$\chi^2$ to degrees of freedom in the range of 5 to 1	Low $\chi^2$ relative to degrees of freedom with insignificant p value ( $p > 0.05$ )
Relative $\chi^2$	5.0 to 2.0	Adjusts for sample size
RMSEA	Values less than 0.07	Has a known distribution and values less than 0.03 represents excellent fit
GFI	Values greater than 0.95	Scaled between 0 and 1, with higher values indicating better fit model
CFI	Values greater than 0.95	Normed, 0-1 range

Source: Coughlan et al., (2008:192)

The next section describes how the validity and reliability of the collection instrument were ascertained.

## **5.6 VALIDITY AND RELIABILITY OF THE INSTRUMENT**

According to Babbie (2013), the validity and reliability of the data collection measurement influence the extent to which one can learn from the phenomenon being studied, the probability of statistical significance and the extent to which meaningful conclusions can be drawn from the data. It was therefore deemed necessary to ascertain the validity and reliability of the questionnaires used in this study.

### **5.6.1 Validity**

According to Babbie (2013), validity refers to “the extent to which the empirical measure adequately reflects the real meaning of the concept under consideration”. The validity of an instrument can be concluded from three perspectives: face and content; concurrent, or predictive validity; and construct validity. Face validity refers to the judgement made of the instrument in respect of the logical linkage between the questions asked and the objectives of the research in question. Concurrent



validity refers to the degree to which one instrument compares with another when they are concurrently administered. Predictive validity in contrast, refers to the extent to which an instrument can easily predict or forecast the outcome of a study. Hence, to ascertain the validity of the instrument, it is necessary to conduct the construct validity test.

In the current study, both the face validity and the construct validity tests were conducted. Face validity, the first step towards authenticating the validity of the survey instruments, was sought through a review of the draft questionnaires by academics and bank managers who are experts in SME financing. Once completed, feedback was incorporated and a revised draft of the questionnaire produced. The construct validity was established by means of an exploratory factor analysis (Hair et al. 2014). Cronbach's alpha has a theoretical relation with factor analysis. Cronbach's alpha was therefore used to determine the reliability of the constructs used in this study, based on the relationship it has with exploratory factor analysis. According to Hair et al (2014), exploratory factor analysis is used to condense a large set of variables or scale items down to a smaller and manageable number of dimensions or factors.

Two statistical measures which were generated from SPSS were used to assess the factorability of the data used in this study. The two measures are:

- Bartlett's test of sphericity (Pallant, 2010) which should be significant ( $p < 0.05$ ) for the factor analysis to be considered appropriate.
- The Kaiser Meyer-Olkin (KMO) measure of sampling adequacy. KMO values of between 0.7 and 0.8 are considered good values for factor analysis, while values of between 0.8 and 0.9 are regarded as excellent values (Pallant, 2010).

Two other techniques that were used in the study in determining the number of factors to retain are:

- Kaiser's criterion or the eigenvalue rule. The eigenvalue of a factor represents the amount of the total variance explained by that factor. According to

Tabachnick and Fidell (2007), an eigenvalue of 0.60 represents a good fit to the data.

- Catell's scree test. This involves plotting each of the eigenvalues of the factors, and inspecting the plot to find a point at which the shape of the curve changes direction and becomes horizontal (Pallant, 2010).

Based on the feedback received from the pilot study, the questionnaire could be regarded as valid.

### **5.6.2 Reliability**

Reliability is the consistency with which a measuring instrument yields certain results when the entity being measured has not changed (Leedy and Ormrod, 2010). It is the extent to which set of variables is consistent in what it is intended to measure (Hair et.al. 2014). Cronbach alpha was used to measure the reliability, that is, the internal consistency of each dimension. The internal consistency is the extent to which all of the items within a single instrument yield similar results (Leedy and Ormrod, 2010). It was used to determine how unified the items in the dimension are (Salkind, 2012). A "high" value of alpha is often used (along with substantive arguments and possibly other statistical measures) as evidence that the items measure an underlying (or latent) construct. According to George and Mallery (2003), the rule of thumb states that the goodness of fit of a measuring instrument lies along a continuum. An alpha > 0.9 = excellent; > 0.8 = good; > 0.7 = acceptable; >0.6 = questionable; >0.5 = poor and < 0.5 = unacceptable. However, the generally agreed lower limit for Cronbach's alpha is 0.7, although it may decrease to 0.6 in exploratory research (Hair et al., 2014). In this particular research, 0.6 is also used as an acceptable level. The following reliability measures are considered.

**Table 5.4:** Reliability results of dimensions

<b>Factor</b>	<b>No. of items</b>	<b>Cronbach's alpha</b>	<b>Acceptable level</b>
Credit supply	6	0.737	Acceptable
Bank involvement with SME	7	0.870	Good
Obstacles in SMEs Lending	13	0.708	Good
Cost reducing techniques	5	0.804	Good
Response to excess demand	4	0.727	Acceptable
Lending technology	5	0.730	Acceptable
Measures of creditworthiness	4	0.757	Acceptable
Credit screening	7	0.746	Acceptable
Transactional costs	4	0.720	Acceptable
Bank-SME relationship	4	0.702	Acceptable
Collateral	3	0.671	Acceptable
Risk management	4	0.611	Acceptable
Factors hindering approval of SME loan application	10	0.723	Acceptable
Innovative strategies	2	0.622	Acceptable
Risky nature of SMEs	9	0.706	Acceptable
<b>Total</b>	<b>97</b>	<b>0.835</b>	<b>+Good</b>

Some of the aspects were removed from the analysis to increase the reliability of the instrument. The targeted threshold level was 0.7. A reliability of 0.6 was only accepted if removal of factors could not improve on the reliability. The items removed from the dimensions to increase reliability are given in Appendix C.

A Cronbach's alpha of 0.7 or more indicates a reliable scale. All the other dimensions had reliability scale of more than 0.7 except the dimensions "*collateral (0.671)*", "*risk management (0.611)*" and "*innovative strategies (0.622)*". According to Hair et al. (2014), in practical research a reliability of 0.6 is acceptable. Thus the reliability of these dimensions was at acceptable levels. The reliability of the revised instrument was 0.835 which is good and thus overall the instrument was regarded reliable.

Another method of factor comparison used in the study is the Pearson's coefficient. This method was chosen because of its ability to determine the differences in two factors' pattern of loading and also to determine the differences (or similarities) in the magnitude of these loadings. Chapter 6 presents the details of how these measurements were used and interpreted. The next section briefly describes the limitations of the study.

## **5.7 METHODOLOGICAL LIMITATIONS**

Limitations in the methodology relate to the non-availability of a database with accurate records of SMEs both nationally and at provincial level. To overcome this hurdle, reliance was placed upon membership registers obtained from organisations affiliated to SMEs and Braby's.com database. The study was also faced with financial and time resource constraints and was therefore limited to Gauteng province - one of the nine provinces of South Africa, with the highest number of SMEs in the country.

## **5.8 ETHICAL CONSIDERATIONS**

The researcher's ethical responsibility to the participants and funders of the project is vital (McGivern, 2006). Where there is conflict, the participants' rights, as individuals, must come first. According to Van der Wal (2006), researchers must do everything in their power to protect the physical, social, and psychological welfare, and to honour the dignity and privacy of those studied. There are three types of ethical guidelines for surveys that a researcher should consider. These are permission to conduct the survey, informed consent and confidentiality (the right to privacy and protecting identification). The following guidelines focus on how ethical factors were addressed in the study.

### **5.8.1 Approval to conduct the study**

Ethical clearance was obtained in writing from the Research Ethics Review Committee of the College of Economic and Management Sciences at the University of South Africa (see Appendix F). Permission was obtained in writing from the SME Unit Managers of the commercial banks in South Africa (see Appendix D) and the SME owner/managers (see Appendix E).

### **5.8.2 Informed consent**

Informed consent relates to the principle of voluntary participation in research (McGivern 2006:28). Informed consent describes the nature of the research project, as well as the nature of one's participation in it (Leedy and Omrod, 2010). The purpose of the research was explained to the participants by the researcher via a cover letter attached to the questionnaire (see Appendices D & E). Participants were informed that participation is voluntary and they had the right to withdraw from the study at any time.

### **5.8.3 Confidentiality**

Ensuring the anonymity and confidentiality of participants and the data they provide are two ways in which the well-being and interests of respondents can be protected (Gray et al. 2007). During this study, participants were informed about the nature of the study that was being conducted. The questionnaire's covering letter (Appendix D and E) clearly indicated the purpose of the study and most importantly the voluntariness of participation. Participants were assured of the confidentiality in handling their responses and their freedom to withdraw their participation should they opt not to participate. No reference was made to any individual in the presentation of the results, the analysis of data and the discussion of the outcomes. The respondents were informed that the survey data would be kept confidential and destroyed after five years.

### **5.8.4 Justice and beneficence**

Justice requires that people participating in the research should not be treated unfairly. The outcome of the questionnaire did not affect the social lives of the SME owners/managers and bank officials (Creswell, 2009:89). The research will ultimately benefit SME owners/managers and bank officials and did not harm them. In other words, the research was advantageous rather than harmful. Moreover, no potential harm or discomfort for the participants is foreseen, since their names or identities would not be disclosed.

## **5.9 CHAPTER SUMMARY**

Chapter five discussed the use of the research onion as the guideline to conduct the study. The researcher used a deductive approach with this quantitative study which was conducted using a self-administered closed-ended questionnaire. The sample for the research was taken from individuals who represent the SMEs and bank officials with a total of 400 questionnaires distributed to the banks and 500 questionnaires to the SMEs in the Gauteng province. The stratified systematic probability sampling method was used to select the sample. To ensure appropriateness and ease of understanding of the research instrument, pre-testing was done using respondents with similar characteristics before embarking on a larger sample.

The chapter also indicated how validity and reliability of the research instruments were determined. Bartlett's test of sphericity and the Kaiser Meyer-Olkin (KMO) measure of sampling adequacy were used to test the factorability of data in this study. The eigenvalue rule and Catell's scree test were also used to determine the number of factors required to retain validity.

The reliability of the instrument was tested using Cronbach's alpha and the Pearson correlation coefficients by determining the internal consistency of items or factors in the study. Finally, the chapter explained the data analysis techniques used in the study which included descriptive statistics and the use of the structural equation modelling (SEM). A detailed report of the analysis of data collected from both the bank and SME surveys is presented in Chapter six.

## **CHAPTER 6**

### **ANALYSIS AND INTERPRETATION OF THE RESULTS**

#### **6.1 INTRODUCTION**

The aim of this research was to empirically investigate the main factors which determine the credit rationing behaviour of banks in South Africa. This study focused on uncovering why commercial banks are discriminatory against SMEs and what could possibly be done to enhance a better efficiency of the financial intermediation process, regarding the ratio of capital that is directed to the SMEs. This chapter presents the findings of both the banks survey and the SMEs survey. The first part of the chapter presents the findings of the bank questionnaire, while the results of the SME questionnaire are presented in the second part.

For both surveys, the analysis contained in this chapter will commence with the presentation of non-parametric demographic estimations of both samples. This is followed by the presentation of the validity and the reliability tests of the constructs of the measures used in the analysis. The model fit and validity tests are done and the hypotheses are tested. In addition, the correlation between the decision variables influencing SME financing is tested to determine whether there is any significant association between the variables identified. Multiple regression analysis is then used to determine the main factors influencing credit supply to SMEs in South Africa. Finally, structural equation modelling (SEM) was used to investigate the main latent (unobserved) factors influencing credit supply to SMEs by banks in South Africa and factors influencing SME access to finance. The chapter concludes with a summary of the results. The following section presents the results and discussion of findings from the bank survey.

#### **6.2 PART ONE: ANALYSIS OF THE RESULTS OF THE BANK SURVEY**

The specific objectives of the bank survey were fivefold; firstly, to investigate the extent of the banks' involvement with SMEs; secondly, to explore the drivers of bank financing to the SME sector; thirdly, to investigate the obstacles to bank financing; fourthly, to determine how banks manage credit risk associated with SME financing; and lastly, to determine the factors that influence the supply of credit to SMEs by

banks in South Africa. The following section discusses the characteristics of the bank sample.

### 6.2.1 Characteristics of the sample

A total of 400 questionnaires were distributed to the banks in the Gauteng province of South Africa, of which 202 were returned, which represents a 51% response rate. Of the 202 questionnaires returned, 188 were suitable for analysis. The demographic information of the 188 participants is shown in Table 6.1.

**Table 6.1:** Demographic profile of the frequency distribution of the sample

<b>Years of banking experience</b>	<b>Frequency</b>	<b>Percentage</b>
At most two years	55	29.3
3-5 years	39	20.7
6-10 years	54	28.7
11-15 years	31	16.5
Above 15 years	9	4.5
<b>Bank position</b>		
Banker	59	31.4
Small business services manager	34	18.1
Relationship manager	46	24.5
Credit manager	16	8.5
Risk manager	14	7.4
Supervisor	15	4.8
Credit analyst	4	2.1

### 6.2.2 Level of experience of respondents

The practical experience in SME financing of the respondents is graphically depicted in Figure 6.1. The respondents' level of banking experience ranged from just below two years (29.3%) to over 15 years (4.5%). The 6-10 year category comprised of 28.7% of the respondents, 3-5 years amounted to 20.7% and 11-15 years constituted 16.5% as shown in Table 6.1. A summary of these experiences is given in Figure 6.1.



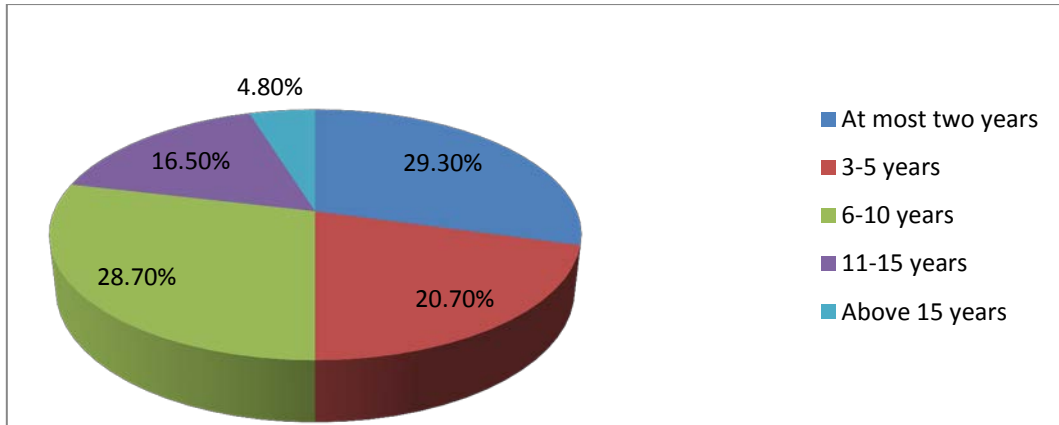
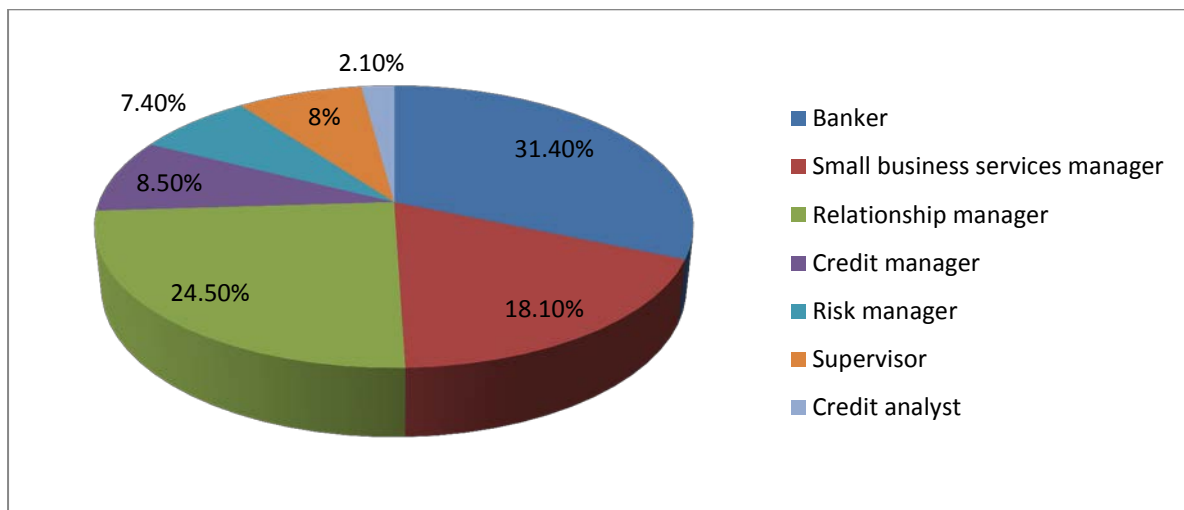

**Figure 6.1:** Level of banking experience of respondents

It can be inferred that the questionnaire was completed by mostly experienced managers who were able to give valuable information. Hence the findings can be regarded as a true reflection of the human capital dynamics in the banking sector in the focus area. The next section discusses the job position of the respondents.

### 6.2.3 Job position of the respondent

The respondents occupied a range of job positions, including banker, relationship manager, small business services manager, credit manager, risk manager, supervisor and credit analyst. These job positions are presented graphically in Figure 6.2.



**Figure 6.2:** Job positions of respondents

The specific occupations/positions of the respondents (see Figure 6.2) indicate that mostly bankers (31.40%) and relationship managers completed the questionnaire. It

can be deduced that SME financing is still being regarded as an overall responsibility rather than consisting of separate specialised areas. Only 8% of the respondents were credit managers while 7.4% were risk managers and 2 % were credit analysts. This is an indication that SME financing is still regarded as part of the personal banking function in most bank branches in Gauteng. The next section investigates the banks' involvement with SMEs in the Gauteng province of South Africa.

### 6.3 BANKS' INVOLVEMENT WITH SMEs

The first objective of this study was to investigate the extent of banks' involvement with SMEs. Figure 6.3 below shows that the majority of respondents (88%, n=188) attested to their bank having a separate unit that is responsible for managing SMEs relations, while only 12% were not involved with SMEs at all. This is an indication that most banks find it worthwhile to do business with small businesses; hence there is a move from the conventional thinking that banks are not interested in doing business with SMEs.

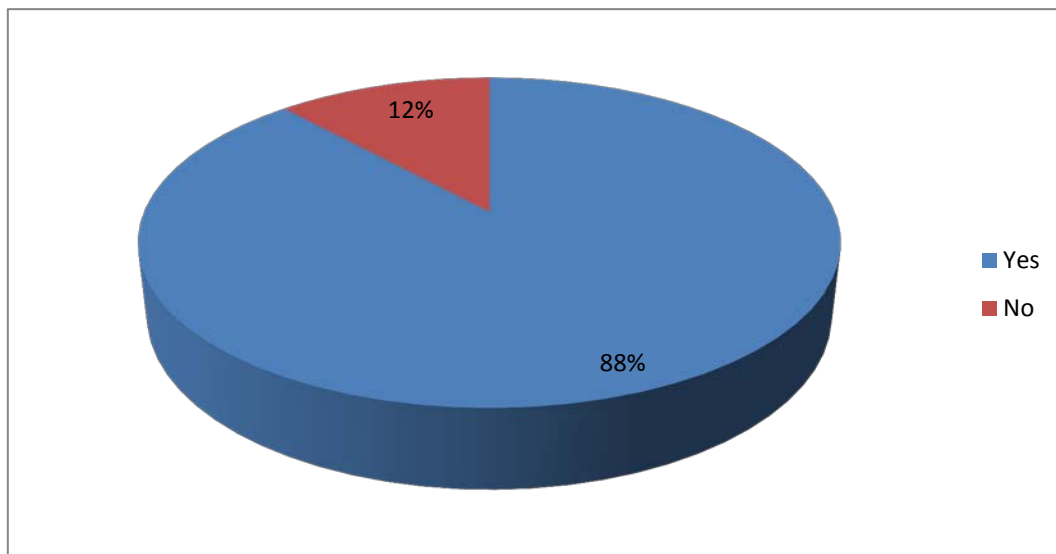

**Figure 6.3:** Bank's involvement with the SME sector

This indicates that in general, the banks regard the SME segment as a strategic sector, and therefore dedicate specific units to manage the banking relations. This appears to be the current trend as recent literature demonstrates. For example in the 2012 Ghana Banking Survey (Yeboah, Asirifi & Adigbo, 2014), it was established

that almost all banks in Ghana had established SME banking units and had acquired the capacity to address the peculiar needs of SMEs.

### 6.3.1 Use of short-term and long-term products

The respondents were further asked to indicate the extent to which banks offer certain lending products to SMEs. There were six lending products and the scale items “to a large extent” and “to a very large extent” were combined together to give the rankings in Table 6.2. The survey results indicate that there is a high demand for short-term loans in the form of credit cards (90.9%), overdraft (87.1%) and short-term loans (63.3%).

**Table 6.2:** Lending products offered to SMEs by banks

Statement	Level of Extent				Sample Size	Rank
	To a very large extent	To some extent	To a little extent	Not to an extent at all		
Credit cards	90.9% (169)	3.8% (7)	1.1% (2)	4.% (8)	186	1
Overdraft	87.1% (162)	8.6% (16)	0.5% (1)	3.8% (7)	186	2
Short-term loans	63.3% (117)	25.9% (48)	9.7% (18)	1.1% (2)	185	3
Vehicle and asset finance	55.7% (103)	28.1% (52)	11.4% (21)	4.9% (9)	185	4
Mortgage loan	29.10% (54)	40.5% (75)	21.6% (40)	8.6% (16)	185	5
Bond for premises	28.8% (53)	32.1% (59)	28.8% (53)	10.3% (19)	184	6

According to Table 6.2 the vehicle and asset finance product (55.7%) was ranked fourth while long term loans that include home loans (29.1%) and mortgage bond for business premises (28.8%) were ranked fifth and sixth respectively. According to the analysis, it seems that less long-term loans are supplied to SMEs by the banks. It can therefore be concluded that the banks predominantly offer short-term credit to SMEs, which does not need collateral for security as opposed to the asset-based finances.

It is further observed that banks offer SMEs a wider variety of products than just bank loans. The principal components of these products are both asset-backed and unsecured lending that take the form of overdraft, credit cards, vehicle and asset finance, and mortgage loans as shown in Table 6.2. Consistent with the general view that the SME sector is strategically important to South African banks and the market is increasingly competitive, banks need to develop unique products meant for SMEs. Based on the findings above, banks should be prepared to invest in product development as they pursue a differentiation strategy. The next section addresses the reasons for banks' involvement with SMEs.

### 6.3.2 Drivers for banks' involvement with SMEs

The second objective of the study was to determine the drivers behind the banks' participation in the SME market. The purpose was to investigate the factors driving South African banks' desire to become involved with SMEs. The results of the analysis are presented in Table 6.3 below.

**Table 6.3:** Descriptive statistics for banks' involvement with SMEs

Series	Drivers of banks' involvement with SMEs	N	Min	Max	Mean	Std. Deviation
1	Perceived profitability	186	1	5	3.90	0.898
2	Reverse factoring through large clients	182	1	5	3.15	0.901
3	Excessive exposure to retail customers	179	1	5	3.01	0.719
4	Competition for large corporates	184	1	5	2.84	0.872
5	Excessive exposure to large firms	183	1	5	2.77	0.898
6	Competition for retail customers	184	1	5	2.76	0.911
7	Corporate social responsibility	186	1	5	1.95	1.140
	Valid N (listwise)	175				

Source: SPSS 23

The information in Table 6.3 is graphically depicted in Figure 6.4 below.

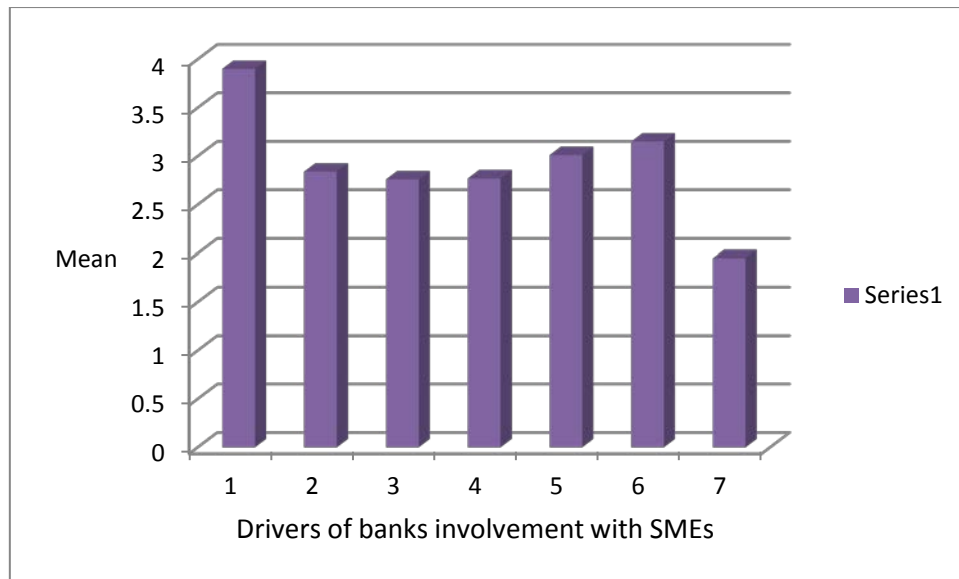

**Figure 6.4:** Drivers of banks' involvement with SMEs

Based on Table 6.3 and Figure 6.4, perceived profitability with the highest mean score of 3.90 is a decisive factor in banks' decision to target the SME sector. The second driver is reverse factoring (the need to seek out SME relationships from existing large corporate clients) with a mean score of 3.15. This is probably due to the existence of a well-developed corporate sector in the Gauteng province of South Africa. Other drivers include the need to reduce exposure to both corporate and retail customers. According to De la Torre, Martinez Peria and Schmukler (2010), profits from corporate banking are dwindling due to intense competition from capital markets and exposure to the retail sector. The least important driver is the need for corporate social responsibility with the lowest mean score of 1.95. This result signifies that banks do not get involved with SMEs just for corporate responsibility purposes, but for the perceived profitability. From the discussion above, it can be concluded that the SME segment is now being considered as a potential market with great prospects for growth. However, in dealing with SMEs, banks face a number of obstacles which will be discussed in the following section.

#### **6.4 OBSTACLES TO SME FINANCING**

The third objective of the study was to determine the obstacles to SME financing. The purpose was to identify the factors which caused the banks most concern and were perceived as the foremost impediments to SME financing. Based on the scale

used in the questionnaire, the scale items “significant”, “very significant” and “extremely significant” were grouped together to determine the intensity of the rankings as demonstrated in Table 6.4 below.

**Table 6.4:** Obstacles to SME financing

Obstacle	Level of Significance				Sample Size	Rank
	Extremely significant & very significant	Significant	Marginally significant	Not significant		
FICA regulations	95.7% (180)	4.3% (8)	-	-	188	1
Bankruptcy regulations	94.0% (177)	5.9% (11)	-	-	188	2
Lack of adequate demand from creditworthy customers	89.4% (168)	8.0% (15)	2.7% (5)	-	188	3
Lack of collateral	85.6% (161)	12.2% (23)	2.1% (4)	-	188	4
Information asymmetry	84.6% (178)	4.3% (8)	1.1% (2)	-	188	5
Difficulty in standardizing products and procedures	79.8% (150)	18.1% (34)	2.1% (4)	-	188	6
High costs of lending technologies	75.9% (141)	22.0% (41)	1.6% (3)	0.5% (1)	186	7
Inability to diversify risk across borrowers	55.6% (104)	42.8% (80)	1.6% (3)	-	187	8
Inability of SMEs to manage risk	45.2% (85)	47.3% (89)	6.9% (13)	0.5% (1)	188	9
Increasing interest rates	22.6% (42)	39.8% (74)	33.9% (63)	3.8% (7)	186	10
High fixed costs per transaction	11.3% (21)	30.6% (57)	52.7% (98)	5.4% (10)	186	11
Fluctuating exchange rates	3.8% (7)	31.9% (59)	35.7% (66)	28.6% (53)	185	12

It is observed that the Financial Intelligence Centre Act (FICA) - Act 38 of 2001 regulations, bankruptcy regulations, and SME-specific factors such as lack of adequate demand from creditworthy customers (there is demand but from customers that are not creditworthy), lack of collateral, information asymmetry and inability of

SMEs to manage risk are the most important obstacles that limit banks from lending to SMEs. According to the preamble of the FICA Act, it is envisaged too regulate the accumulation and appropriation of proceeds of unlawful activities. FICA regulations rank as the most important obstacle to SME financing because the majority of SMEs do not meet the requirements of a physical address for the business, proof of company registration and a credit history. Therefore, it can be concluded that the easiness of doing business in South Africa is hampered by regulation. These findings are in support of Aregbeshola (2010) who found that the FICA regulation had a negative impact on the growth automobile industry in South Africa. Attention is also drawn to problems of organisational nature, such as difficulty in standardizing products and procedures (screening, origination, monitoring, and risk management), high implementation and maintenance costs of lending technologies, inability to diversify risk across borrowers and high fixed costs per transaction.

Lastly, macro-economic factors including interest rates and fluctuating exchange rates were also listed as deterrent factors to bank-lending to SMEs. Identification of these obstacles should be seen as a positive sign representing a forward-looking approach towards better quality and wider variety of bank services. Improvements on these fronts would certainly contribute towards alleviating the problems of insufficient demand for credit; shorten the time and complexity of credit application and risk-evaluation procedures, and perhaps to lower banks' requirements concerned with level of loan collateralisation. However, prior studies including Calice et al, (2012) have found that information asymmetry is the most important obstacle to bank financing to SMEs in Kenya, Uganda and Zambia. In South Africa, information asymmetry is ranked fifth. This is so because in South Africa banks can easily access information about the borrowers from the credit bureaux at any point in time. Furthermore, South Africa's banking industry is far ahead in terms of technological development and financial regulation. Therefore, it can be concluded that South African banks are more concerned about SME compliance to financial regulation, creditworthiness and the issue of collateral to secure the bank loans than information asymmetry.

The respondents were further asked to indicate the criteria the banks use to determine the preference of their SME clientele. This question, by construct, is

multifaceted and specifically designed to gain multiple responses that are required to answer the research questions and test the related research hypotheses. The responses generated through the questions to determine the criteria used by banks to target SMEs clients are presented in Table 6.5.

**Table 6.5:** Criteria used by banks to determine SMEs clients

<b>Measure</b>	<b>Frequency</b>	<b>%</b>	<b>Rank</b>
Credit quality	186	98.9	1
Expected profitability of the firm	183	97.3	2
Exposure size	171	91.0	3
Company size	163	86.7	4
Geographic area where the firm operates	132	70.0	5
Industry sector to which the firm belongs	100	53.2	6
Product needs of the firm	18	9.6	7

As indicated in Table 6.5, banks mainly use credit quality (98.9%); expected profitability of the firm (97.3%), size of exposure (91%) and company size (86.7%) to determine which SMEs to finance. Together, these criteria determine the creditworthiness of the SMEs, which according to theory, is a major determinant of SME financing. According to Dietsch and Petey (2002), credit quality is a credit category obtained by distributing the loans across the bank internal risk rating system, which assigns each loan to one of the risk classes. Credit quality is therefore used to assess the probability that the borrower will move to the default class over a given time. Credit quality is often assessed through the process of credit scoring. According to 9.6% of the respondents, banks use product needs of the SMEs as criteria to determine their credit worthiness to access funding, while 53.2% of the respondents indicated that banks also consider the specific sector in which the SMEs operate. Banks consider some sectors of the economy to be too risky to invest. Such sectors include mining and construction. The geographic area where the firm operates was only ranked in the fifth position. This could be influenced by the fact that the research sample is only located in Gauteng.



The respondents were further asked to indicate their level of awareness of cost-reducing techniques that are being used by other banks across the world for SME financing. These techniques include use of low-cost branches, correspondent banking, contact centre models, mobile telephone banking and point of sale systems (POS). The scale items “very aware” and “extremely aware” were grouped together to give the rankings in Table 6.6.

**Table 6.6:** The level of awareness of cost-reducing techniques in SMEs financing

Statement	Level of Awareness				Sample Size	Rank
	Extremely aware and Very aware	Somewhat aware	Slightly aware	Not at all aware		
Use of low-cost branches	70.7% (133)	19.1% (36)	4.3% (8)	5.9% (11)	188	1
Use of correspondent banking	70.2% (132)	18.1% (34)	5.9% (11)	5.9% (11)	188	2
Use of contact centre models	70.2% (132)	15.4% (29)	7.4% (14)	6.9% (13)	188	2
Use of mobile phone-based products	63.0% (174)	4.8% (9)	-	2.1% (4)	187	4
Use of Laptops and Point of Sale (POS) systems	55.9% (105)	30.3% (57)	6.4% (12)	7.4% (14)	188	5

The information contained in Table 6.6 suggests that 70.7% of the respondents are aware of the low-cost branches technique that is adopted by the banks. It may be opined that the low-cost branch technique is adopted in order to boost accessibility to banking facilities in the less-privileged communities. The other techniques banks are highly aware of include methods such as the use of correspondent banking (70.2%) and mobile phone-based products (63%). The use of laptops and point-of-sale techniques were ranked fifth, indicating that these cost-reducing techniques were not popular amongst the banks under study (see section 3.8 of chapter 3).

Lending institutions should strike a balance between the cost of providing products and services to SMEs and the return derived from such an investment. Therefore, banks must meet their client’s needs at the lowest possible costs in terms of

distribution and nature of products and services offered to SMEs. Distribution can be achieved through the provision of low-cost branches and the extensive use of correspondent banking. According to literature, correspondent banking involves the use of retail outlets by banks to expand their distribution reach. The empirical results of this study are similar to those of an earlier study by Stephanou and Rodriguez (2008), where similar investigation was conducted in Colombia and the one bank was found to be using over seven hundred retail outlet branches. The next section addresses the response of banks to excess demand for credit by SMEs.

There were 4 items measuring the response to excess demand for credit by SMEs. Scale items “strongly agree” and “agree” were grouped together to give the rankings in Table 6.7.

**Table 6.7:** The bank’s response to excess demand for credit by SMEs

Statement	Level of Agreement				Sample Size	Rank
	Strongly agree	Neutral	Disagree	Strongly disagree		
Increase collateral requirements to clear the excess demand	41.5% (76)	38.8% (71)	16.4% (30)	3.3% (6)	183	1
Decline credit to customers regarded as high risk borrowers	39.9% (66)	8.2% (15)	15.8% (29)	36.1% (73)	183	2
Decline credit to customers because it is unprofitable at any interest rate	36.1% (54)	29.0% (53)	30.1% (66)	4.9% (9)	183	3
Keep interest rate low and randomly select loan applicants	3.8% (7)	20.8% (38)	30.6% (56)	44.8% (82)	183	4

According to Table 6.7, the survey results indicate that the most common response of banks to excess demand by SMEs is the increase of collateral requirements with 41.5%. This is followed by the decline of credit directed to clients that are regarded as high risk borrowers (39.9%). Respondents were in agreement that banks decline credit to SME clients because it is unprofitable at any interest rate (36.1%). However, there was unanimous disagreement that banks keep interest rate low and randomly select SME loan applicants (44.8%). This suggests that most of the banks rarely use this method in responding to excess demand for credit by SMEs. The above analysis

indicates that banks tend to increase collateral requirements to clear excess demand and decline credit to SME clients regarded as high risk borrowers, and those with unprofitable businesses.

According to Stiglitz and Weiss (1981), higher demand for collateral can reduce risk and increase return for the bank. Voordeckers and Steijvers (2008) argue that increasing the demand for collateral by banks makes the average marginal borrower become more risky. Thus, the findings of this study corroborate those of Stiglitz and Weiss (1981:442) which indicate that banks may use increased collateral requirements to eliminate excess demand.

#### 6.4.2 Credit risk management

The fourth objective of the study was to determine how banks manage the credit risk associated with lending to SMEs. The question that investigated the application of the existing credit risk management functions in the targeted banks indicated that close to 190 valid responses were generated. The results are presented in Table 6.8.

**Table 6.8:** The organization of the credit risk management function.

Credit risk function	Frequency	%	Rank
Done primarily at head office	172	91.5	1
Done by credit risk analyst	113	60.1	2
Done by the relationship manager at the branch	37	19.7	3
Largely automated	2	1.1	4

As shown in Table 6.8, 91.5% of the respondents indicated that the credit risk management function was done primarily at the bank head office whilst 60.1% indicated that this specific function was done by a credit risk analyst. This finding is in support of Calice et al. (2012) and de la Torre et al (2008) in Colombia. The results also indicate that the credit risk management function was done by the relationship manager at the branch as indicated by 19.7% of the respondents. However, only 1.1% of the respondents attested to the fact that the credit risk management function was largely automated. Thus it can be concluded that the

credit risk management function is largely centralised and overseen by credit analysts. Furthermore, the authors established that with the improvement in technology, risk management for SMEs is increasingly being automated in banks in Kenya, Tanzania, Uganda and Zambia.

The respondents were also asked to indicate the extent to which their banks used the different lending technologies to screen SMEs applications. The scale items, “to a large extent” and “to a very large extent” were grouped together to give the ranking in Table 6.9.

**Table 6.9:** To what extent does the bank use the following lending technologies to screen SMEs loan applications?

Lending technologies	Level of Extent				Sample Size	Rank
	To a very large and large extent	To some extent	To a little extent	No to an extent at all		
Financial statement lending	86.20% (162)	12.2% (23)	0.5% (1)	1.1% (2)	188	1
Asset-based lending	85.10% (160)	13.8% (26)	-	1.1% (2)	188	2
Leasing	68.60% (129)	26.1% (49)	3.2% (6)	2.1% (4)	188	3
Factoring	16.5% (31)	56.4% (106)	21.3% (40)	5.9% (11)	188	4
Credit scoring	7.5% (14)	63.4% (118)	23.7% (44)	5.4% (10)	186	5

The study has shown that financial statement lending is the most important technique used by banks to screen SMEs (86.2%), followed by asset-based lending (85.10%) and leasing (68.60%). It is interesting to note that factoring (16.5%) and credit scoring (7.5%) were ranked fourth and fifth respectively as techniques for screening SME loan applications. Financial statement lending appears to be the most commonly used technique by the sampled banks to screen SME loan applications. Credit scoring appears not to be a suitable technique for screening SMEs as they are characterised by information asymmetry and demand small loans. According to

Stephanou and Rodriguez (2008), automatic scoring models are usually applied to SMEs in need of small loans but the majority of the SMEs do not possess the required documentation to enable this process.

The respondents indicated their levels of agreement on the use of measures the banks adopt to monitor SMEs activities. “Strongly agree” and “agree” were grouped together to give the rankings in Table 6.10.

**Table 6.10:** What are the measures used to monitor SMEs?

Measure	Level of Agreement				Sample Size	Rank
	Strongly agree	Neutral	Disagree	Strongly disagree		
Risk exposure	87.20% (164)	9.6% (18)	2.1% (4)	1.1% (2)	188	1
Repayment ability	74.1% (158)	16.0% (30)	-	-	188	2
Total debt outstanding	64.9% (122)	33.5% (63)	1.6% (3)	-	188	3
Deterioration of cash flow	45.7% (86)	40.4% (76)	11.7% (22)	2.1% (4)	188	4

As shown in Table 6.10, the most common measure used by banks to monitor SME performance on their loan obligations is the risk exposure (87.2%), followed by repayment ability (74.1%), total outstanding debt (64.9%) and deterioration of cash flow (45.7%). Outstanding debt can be regarded as total principal plus interest amount of a debt that is yet to be paid (debt that has not been paid in full), while risk exposure refers to how large the outstanding debt will be in the event of a default. This suggests that lesser resources are committed to monitoring the repayment frequency of SMEs. In terms of the observed variables, outstanding debt and repayment frequency are part and parcel of the risk management processes that are designed to measure the performance of the SME clients (de la Torre et al., 2010). Deterioration of cash flow and outstanding exposures, such as default in repayment and overleveraging are also used as preventative monitoring triggers for most bank branches. The above analysis shows the importance of the monitoring mechanism of

banks as they underpin SME efficiency. The next section focuses on the extension of credit to the different economic sectors by banks.

Respondents were further asked to indicate whether bank financing to SMEs in the different economic sectors was increasing or decreasing. Table 6.11 indicates the responses to this question.

**Table 6.11:** Which sector do banks prefer to extend credit to?

In your opinion, is bank financing to SMEs in the various economic sectors increasing or decreasing?	Increasing	Unchanging	Decreasing	Sample size	Rank
Agriculture, forestry and fishing	68.4% (117)	28.7% (49)	2.9% (5)	171	1
Electricity, gas and water	64.7% (110)	34.1% (58)	1.2% (2)	170	2
Finance, insurance and business services	31.2% (53)	65.9% (112)	2.9% (5)	170	3
Manufacturing	21.9% (37)	63.3% (107)	14.8% (25)	169	4
Wholesale, retail trade, hotels and restaurants	15.3% (26)	83.5% (142)	1.2% (2)	170	5
Transport, storage and communications	10.1% (17)	87.6% (148)	2.4% (4)	169	6
Mining and quarrying	10.6% (18)	66.5% (113)	22.9% (39)	170	7
Construction	7.1% (12)	37.1% (63)	55.9% (95)	170	8

As illustrated in Table 6.11, 68.4% of the respondents indicated that banks are increasing the extension of credit to SMEs in the agriculture, forestry and fishing and the electricity, gas and water sectors (64.7%). According to the empirical results, bank funding to most sectors of the economy such as finance, insurance and business services, wholesale, retail and transport and communication is stagnant, meaning that the credit extension to these sectors is neither increasing or decreasing. However, according to the responses, funding of SMEs in the construction (55.9%) and mining (22.9%) industries seems to be decreasing.

It can be inferred that banks consider as risky to finance SMEs in the transport, mining and construction sectors, taking cognisance of the impact of recent strikes such as Marikana on the South African economy (Alexander, 2013). Therefore it seems that most SMEs in these sectors do not have access to bank credit. These findings are contrary to the GEM Report (2010) which indicated that about a third of SMEs in South Africa are in consumer services, where barriers to entry into the sector in terms of skills and capital required are low.

The respondents were also asked to indicate the level of agreement on issues relating to the screening of SME loan applications. The scale items “strongly agree” and “agree” were grouped together to give the rankings shown in Table 6.12 below.

**Table 6.12:** Which methods are used by your bank to screen SMEs applications?

Method of screening SME loan applications	Level of Agreement				Sample Size	Rank
	Strongly agree	Neutral	Disagree	Strongly disagree		
Availability of collateral	78.1% (136)	17.2% (30)	4.0% (7)	0.6% (1)	174	1
Information from other banks	77.1% (135)	17.1% (30)	4.6% (h8)	1.1% (2)	175	2
Both interest rate and collateral requirements	32.6% (57)	58.9% (103)	8.6% (15)	-	175	3
An increase in interest rate	32.0% (56)	23.4% (41)	34.3% (60)	10.3% (18)	175	4
Third party evaluations	26.9% (47)	22.3% (39)	9.1% (16)	41.7% (73)	175	5
Personal interviews	9.7% (17)	13.1% (23)	69.7% (122)	7.4% (13)	175	6
Site visits	5.7% (9)	18.9% (33)	71.4% (125)	4.0% (7)	175	7

Based on Table 6.12, the respondents indicated that their banks use increasing collateral (78.1%) and information from other banks (77.1%) to screen SME applications. In some instances, banks use both interest rate and collateral requirements (32.6%) while in other cases banks use an increase in interest rates

(32%) to screen loan applications. Personal interviews (9.7%) and site visits (5.7%) seem to be infrequently used to screen new SME loan applications. Rather, site visits are used to monitor SMEs with existing loans (Yeboah, Asirifi and Adigbo, 2014). It can therefore be concluded that availability of collateral is the most important method of screening SME loan applications. The next section focuses on the factors that lead to high transaction costs when banks lend to SMEs.

Respondents were asked to indicate their levels of agreement on the factors that lead to high transactional costs associated with bank financing to SMEs. The scale items 'strongly agree' and 'agree' were combined to give the rankings in Table 6.13.

**Table 6.13:** Which factors lead to high transaction costs when lending to SMEs?

Factors leading to high transaction costs	Level of Extent					Sample Size	Rank
	Strongly agree and agree	Neutral	Disagree	Strongly disagree			
High riskiness of the SMEs due to information asymmetry	88.5% (150)	10.9% (19)	0.6% (1)	-		174	1
Large number of firms to investigate	34.5% (60)	42.5% (74)	21.8% (38)	1.1% (2)		174	2
The wide range of SME projects demanding specialized staff	18.5% (32)	39.3% (68)	35.8% (62)	6.4% (11)		173	3
Lack of standard accounting and auditing techniques	12.8% (22)	30.2% (52)	39.0% (67)	18.0% (31)		172	4

Indicated in Table 6.13, there is unanimous agreement that the high risk posed by SMEs due to information asymmetry (88.5%) and the high number of SMEs to investigate (34.5%) led to high transaction costs when lending to SMEs. Other factors include the wide range of projects demanding specialized staff (18.5%) and lack of standard accounting and reporting techniques (12.8%). Based on the responses, it can be deduced that banks are deterred from lending to SMEs due to information asymmetry and the high costs associated with investigating in a large number of small firms, the majority of which may not satisfy the bank requirements in order to qualify for a bank loan. These findings validate the views of Stephanou and Rodriguez (2008) in Colombia.



### 6.4.3 Relationship lending

According to De la Torre et al, (2010) relationship lending is one of the factors that influence the availability of bank credit to SMEs. Respondents were asked to indicate the extent to which their banks use bank-SME relationships to gather valuable information about the client and to determine the client's ability to pay. The scale items "to a very large extent" and "to a large extent" were combined to come up with the rankings presented in Table 6.14.

**Table 6.14:** What are the objectives of bank-SME relationships?

Objectives of bank-SME relationship	Level of Extent				Sample Size	Rank
	To a very large extent and to a large extent	To some extent	To a little extent	No to an extent at all		
Gather valuable information about the client	85.1% (160)	14.4% (27)	0.5% (1)	-	188	1
Determine the client's ability to pay	69.1% (130)	23.9% (45)	6.9% (13)	-	188	2

As shown in Table 6.14, 85.1% of the banks indicated that bank-firm relationships help the bank gather valuable information about their SME clients, whilst 69.1% indicated that through bank-firm relationships, banks can determine the client's ability to pay. Therefore, the analysis indicated that banks gather valuable information through bank-firm relations, thereby circumventing the disadvantages of information asymmetries. As such, it can be deduced that banks could understand their customers better by establishing bank-SME relationships.

The respondents were further asked to indicate the extent to which certain aspects of the bank-SME relationship were considered by their banks to determine credit availability to SMEs. The scale items 'to a large extent' and 'to a very large extent' were combined together to give the ranking shown in Table 6.15.

**Table 6.15:** Aspects of bank-SME relationship determine credit availability to SMEs?

Aspects of the bank-SME relationship which determine credit availability	Level of Extent				Sample Size	Rank
	To a very large extent and to a large extent	To some extent	To a little extent	No to an extent at all		
Intended use of the loan	96.7% (177)	3.3% (6)	-	-	183	1
Multiple-banking relationships	92.4% (169)	6.6% (12)	1.1% (2)	-	183	2
The range of financial services purchased	44.8% (82)	27.3% (50)	25.1% (46)	2.7% (5)	183	3
Length of the relationship (duration)	16.9% (31)	30.1% (55)	14.8% (27)	38.3% (70)	183	4

From Table 6.15 it can be observed that banks considered to a large extent the intended use of the loan (96.7%), followed by multiple banking relationships (92.4%), the range of financial products and services purchased (44.8%). It can also be noted that the length (duration) of the bank-SME relationship is ranked last indicating that it is not a critical factor in determining credit supply to SMEs by banks. It can thus be suggested that the most important variables for consideration for SME loan approval by banks are the intended use of the loan and the number of banking relationships SMEs have. According to Petersen and Rajan (1994), credit availability to small businesses is enhanced through a durable bank-firm relationship. In support of this statement Cole (1998) posits that banks are more likely to extend credit to an already established relationship but the duration of the relationship is insignificant when making a decision on whether to extend credit or not.

This study furthermore investigated the importance of collateral security as a consideration for loan approval for SMEs. The results of the analysis are presented in Table 6.16.

**Table 6.16:** Types of collateral important for approving SME loan applications

Type of collateral	Level of Extent				Sample Size	Rank
	To a large extent	To some extent	To a little extent	No to an extent at all		
Insurance policies	80.9% (152)	14.9% (28)	2.1% (4)	2.1% (4)	188	1
Property and investments	60.4% (102)	23.1% (39)	13.6% (23)	3.0% (5)	169	2
Plant and equipment (e.g. machinery)	59.0% (111)	31.4% (59)	7.4% (14)	2.1% (4)	188	3

As illustrated Table 6.16, it can be observed that banks consider to a large extent the use of insurance policies (80.9%), followed by property and investments (60.4%) and plant and equipment (59%) as collateral to secure loan applications by SMEs. Use of insurance policies to secure SME loan applications is on the increase because the majority of the SMEs do not possess assets for collateral as per bank requirement. As such, it can be deduced that collateral still remains an important strong deterministic factor for SMEs access to bank credit. This result is consistent with findings of a prior study by de la Torre et al., (2010) which established that pledging assets that do not lose much value overtime and are relatively easy to liquidate (e.g. equipment and real estate) provides greater assurance of repayment, even when contract enforcement processes are relatively imperfect. The next section focuses on the factors that hinder the approval of SME loan applications.

The respondents were asked to indicate the factors that limit banks from approving SME loan applications. Repayment ability of the SMEs (99.4%), lack of collateral (96.3%), capability of SME owner to partly fund the project (93.6%) and lack of education and experience of key management (92.5%) were cited as the major impediments to the approval of bank loans to SMEs as shown in Table 6.17.

**Table 6.17:** Factors hindering approval of SMEs loan

Statement	Level of Importance				Sample Size	Rank
	Very important and important	Neutral	Unimportant	Very unimportant		
Repayment ability of the SME	99.4% (187)	0.5% (1)	-	-	188	1
Lack of collateral	96.3% (181)	3.7% (7)	-	-	188	2
Capability of SME owner to partly fund the project	93.6% (176)	4.8% (9)	1.6% (3)	-	188	3
Education and experience of key management	92.5% (174)	6.4% (12)	1.1% (1)	-	188	4
Compliance with the National Credit Act (NCA)	90.9% (170)	8.0% (15)	1.1% (2)	-	187	5
Inadequate credit history of the SME	71.8% (135)	26.1% (49)	2.1% (4)	-	188	6
Perceived lack of profitability of the firm	61.7% (116)	36.7% (69)	1.6% (3)	-	188	7
Lack of viable and comprehensive business plan	47.9% (90)	45.2% (85)	6.9% (13)	-	188	8
Inadequate information to process loan applications	19.7% (37)	69.7% (131)	10.1% (19)	0.5% (1)	188	9
Lack of bank-SME relationship	16.5% (31)	26.1% (49)	55.9% (105)	1.6% (3)	188	10

Other factors include compliance with the National Credit Act, inadequate credit history, lack of profitability of the firm, lack of viable and comprehensive business plan and inadequate information to process the loan applications. According to Table 6.17, it is worth noting that compliance with the NCA is placed higher as a hindrance to loan approval than credit history. This might be due to the fact that compliance with the NCA is a pre-requisite before any loan application can be processed by the banks". Moreover, the majority of SMEs in South Africa do not meet the requirements of the FICA and NCA regulations such as possession of proof of a physical address, identity document and a clean credit record.

It must however be noted that lack of bank-SME relationship is the least important factor that determines the approval of loan applications by banks. This finding is contrary to the literature, where it is indicated that credit availability is dependent upon the existence of a long-term relationship between the bank and the SME (Giannetti, 2012). It can therefore be concluded that the most important factors hindering the approval of SMEs loans include inability to repay the loan, lack of collateral and inability of the SME owner/manager to partly fund the project. Lack of bank-SME relationship has the least influence on SME loan approvals by banks.

The banking industry is currently undergoing changes in response to swift changing customer behaviour, technological and regulatory realities. Thus banks have to keep pace with changes in technology such as internet and cell phone banking, as more and more SME clients have access to mobile phones and laptops. The study also sought to determine the extent to which banks are using innovative strategies to improve SME access to bank credit. Respondents were asked to indicate the extent to which banks use innovative strategies such as correspondent banking and psychometric testing. The scale items 'to a very large extent' and 'to a large extent' were combined to give the scale rankings shown in Table 6.18 below where the results of the analysis are presented.

**Table 6.18:** Innovative strategies used in SME financing

Innovative strategy	Level of Extent				Sample Size	Rank
	To a very large and large extent	To some extent	To a little extent	No to an extent at all		
Correspondent banking (Use of retailers to expand distribution)	65.2% (120)	29.9% (55)	3.3% (6)	1.6% (3)	184	1
Psychometric testing (using tests, profiles or a combination of the two to form a deeper understanding of the customer)	51.4% (94)	24.6% (45)	14.8% (27)	9.3% (17)	183	2

From the response in Table 6.18, there is an indication that correspondent banking (65.2%) is the leading innovative idea in SME lending, followed by psychometric

testing (51.4%) amongst the banks under study. Psychometric testing involves the use of test scores to separate good risks from bad ones, and is capable of lowering default rates by 25-40%. This self-administered test is done in thirty to forty minutes, and measures attributes such as entrepreneur's psychological profile, ethics and integrity, intelligence and business skills. According to the literature, the cost of assessment is 45% less than the traditional credit assessment measures (Chironga et al., (2012). With correspondent banking, banks use retailers to expand their distribution reach. Therefore, technology can be leveraged to meet the SME clients' needs more effectively and keep credit affordable. The next section deals with the reasons why banks perceive SMEs as risky businesses to invest in. This aspect of the study evaluated eight important factors.

Traditionally, banks are believed to refrain from lending to SMEs because of the risky nature of the small and medium enterprises. Respondents were asked to indicate why banks consider SMEs to be risky entities to invest in, and the results of the analysis are presented in Table 6.19 below.

**Table 6.19:** Factors that make SMEs risky enterprises for banks to do business with

Statement	Level of Extent				Sample Size	Rank
	Strongly agree	Neutral	Disagree	Strongly disagree		
SMEs experience more variable rates of return than large firms	100% (188)	-	-	-	188	1
Difficult to verify financial information for SMEs	100% (187)	-	-	-	188	1
SMEs experience higher failure rates than large firms	99.5% (187)	0.5% (1)	-	-	188	3
SMEs are less equipped in human capital than large firms	98.9% (186)	1.1% (2)	-	-		4
Most SMEs are not completely honest with their financial records and future business plans	97.3% (183)	2.1% (4)	0.5% (1)	-	188	5
Most SMEs are characterised by asymmetric information	87.30% (164)	8.5% (16)	4.3% (8)	-	188	6

SMEs use inadequate accounting systems	62.5% (117)	35.3% (66)	2.1% (4)	-	187	7
Most SMEs are not properly managed	60.1% (113)	27.7% (52)	10.1% (19)	2.1% (4)	188	8

The analysis contained in Table 6.19 indicates that a number of factors contribute to the risky nature of SMEs. Among others, these factors include the variability of SME returns compared to that of large firms (100%); difficulty in verifying financial information (100%); high failure rates (99.5%); dishonesty with financial records (97.3%); information asymmetry (87.3%) and the use of inadequate accounting systems (62.5%) and mismanagement of the majority of SMEs (60.1%). As such, honesty and integrity, yield divergent opinions. However, there is a general consensus that SMEs' managerial competence is questionable. The next section examines the validity of the bank questionnaire, reliability of the constructs identified, correlation, regression analysis and structural equation modelling.

## **6.5 VALIDITY AND RELIABILITY TESTS FOR THE BANK SURVEY**

The bank questionnaire used for this study was subjected to validity and reliability tests using confirmatory factor analysis (CFA) and Cronbach's alpha to determine its appropriateness. To test the convergent validity of the constructs, the exploratory factor analysis (EFA) was employed, firstly to determine whether the individual questions contributed to their respective constructs as contained in the questionnaire, and secondly, to identify the hidden constructs which may not be apparent from direct analysis. Bartlett's test of sphericity and the Kaiser Meyer-Olkin (KMO) measures were used to test the suitability of each question for factor analysis. The results of these tests are discussed in the following sub-section.

### **6.5.1 Validity test: Confirmatory factor analysis**

Table 6.20 depicts the results of the Bartlett's test of sphericity and the KMO value. The KMO showed a value equal to 0.804. The p-value of the Bartlett's test ( $p = 0.000$ ) is smaller than 0.05, is significant at the 99% confidence level. This result is an indication that the correlation structure of construct is adequate to conduct a factor analysis on the items.

**Table 6.20: KMO and Bartlett's Test**

Kaiser-Meyer-Olkin Measure of Sampling Adequacy.		0.804
Bartlett's Test of Sphericity	Approx. Chi-Square	2099.553
	df	406
	Sig.	0.000

*Df – Degrees of freedom*

*Sig – Significance*

Source: SPSS 23

Using the principal component analysis (PCA) and the Varimax with Kaiser Normalisation rotation method, the results of the factor analysis for all the constructs are presented in Table 6.21 below. Eight underlying dimensions were identified as separate factors that relate to credit supply to SMEs by banks.

**Table 6.21: Factor loadings**

		Rotated Component Matrix						
	Proxy	Factor/Component						
		1	2	3	4	5	6	7
21a	High number of firms to investigate	0.650						
21b	Wide range of projects demanding specialized staff	0.677						
21c	High risk due to information asymmetry	0.679						
21e	Lack of standard accounting and auditing techniques	0.614						
25b	Real Estate			0.507				
25c	Plant and equipment			0.508				
25d	Guarantee Schemes			0.509				
16a	Financial statement lending		0.898					
16b	Asset-based lending		0.887					
16d	Leasing		0.863					
16e	Factoring		0.878					
18a	Total debt outstanding				0.690			
18b	Repayment frequency				0.686			
18e	Regular reporting from the SME				0.681			
18f	Risk exposure				0.675			
24a	Distance of the firm from the bank					0.861		
24c	The range of financial services purchased					0.862		
24d	Pre-existing relationship					0.866		
24e	Intended use of the loan					0.851		
28b	Correspondent banking						0.608	
28c	Psychometric testing						0.607	
6c	Vehicle and asset financing							0.818



6d	Credit cards							0.812
6e	Home loan							0.807
6f	Bond for factory/office premises							0.813
	Extraction method: PCA Rotation method: Varimax with Kaiser normalisation							
	<b>a. Rotation converged in 7 iterations.</b>							

(Source: SPSS 23)

As illustrated in Table 6.21, the factor loadings ranged from 0.507 to 0.898, surpassing the minimum threshold required of 0.4. The rotated component factor matrix converged after seven iterations.

Factors extracted represented all variables in the research model. Transaction costs (TC), collateral (C), lending technology (LTech), creditworthiness (CW), bank-SME relationship (BSMER), innovative strategies (IS), credit supply (CS), and risk management (RM) loaded as expected on unique factors with significant loadings (loadings greater than 0.5, (Hair et al., 2005)). As shown in Table 6.21, all items were loaded significantly onto the expected factors, with values higher than 0.4. This supports the discriminant validity of the measurement. It was therefore concluded that the 25-item scale measuring factors in credit supply were uni-dimensional, that is, all the scale indicators that were used in credit supply related questions maintained a single convergence in the analysis suggesting that there is a general agreement among the respondents on issues that relate credit supply to SMEs. The communalities of the identified components are described in the following section.

Communalities show the extent to which individual items in a construct correlate with each other (Hair et al., 2014). Items with extraction values close to 1 have a strong correlation with each other. Using the PCA method of extraction, the communalities for all twenty-nine items presented in Table 6.22, are all observed to be acceptable given that their extraction ranges from 0.535 to 0.818. This implies that there is a strong correlation amongst all the twenty-nine questions.

**Table 6.22: Communalities**

Questions	Extraction	Questions	Extraction	Questions	Extraction
Q22a	0.619	Q16e	0.708	Q28c	0.663
Q22b	0.535	Q18a	0.619	Q6c	0.778
Q22c	0.554	Q18b	0.740	Q6d	0.674
Q22e	0.637	Q18e	0.650	Q6e	0.818
Q25b	0.548	Q18f	0.782	Q6f	0.817
Q25c	0.541	Q24a	0.690	Q19a	0.721
Q25d	0.642	Q24c	0.743	Q19b	0.609
Q16a	0.765	Q24d	0.773	Q19c	0.563
Q16b	0.792	Q24e	0.527	Q19d	0.642
Q16d	0.708	Q28b	0.775		

**Note:** items refer to components, factors or questions.

Source: SPSS 23

Since the study employed the PCA as the method of extraction, the total percentage of variance and cumulative percentage columns are similar to those of the first eight components in the initial eigenvalues. The cumulative variance explained by the factors is shown in Table 6.23.

**Table 6.23: Total variance explained**

Component	Initial Eigenvalues		
	Total	% of Variance	Cumulative %
1	8.106	27.951	27.951
2	2.632	9.075	37.026
3	1.994	6.877	43.903
4	1.778	6.130	50.032
5	1.498	5.165	55.197
6	1.370	4.723	59.921
7	1.174	4.047	63.968
8	1.095	3.775	67.744

Source: SPSS 23

Table 6.23 shows that eight components with eigenvalues greater than one account for 67.74% (highlighted in yellow) of the cumulative variance are above the recommended threshold of 60 percent (Hair et al., 2006). The initial number of factors in the total variance explained is the same as the number of variables used in factor analysis (see Table 6.23). A further analysis was carried out using Catell's

scree plot. The scree plot supports the extraction method of PCA from a diagrammatic point of view as shown in Figure 6.5.

The scree plot test is a graphical method of determining the number of appropriate factors to retain. In Figure 6.5 below, a cut-off of an eigenvalue  $> 1$  would give eight factors. From the 8<sup>th</sup> factor on, the line is almost flat, meaning that each successive factor is accounting for smaller and smaller amounts of the total variance (Su and Yang, 2010). Thus, the scree test results also indicated that eight factors should be retained, supporting the previous result based on the eigenvalue criterion method.

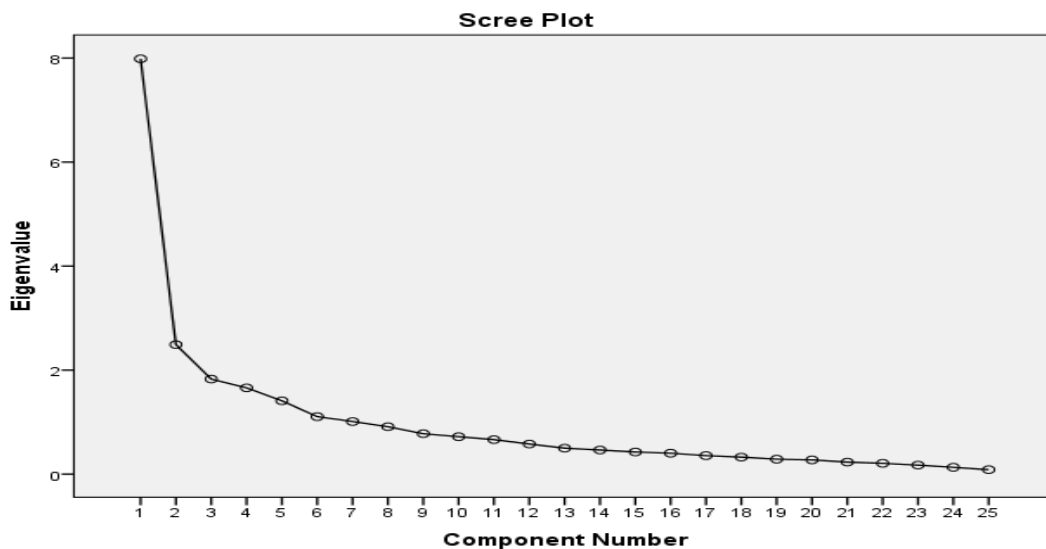

**Figure 6.5:** The Scree Plot test

(Source: SPSS 23)

Having concluded the evaluation of communalities among the determinants of access of SME financing we now proceed to the reliability test.

## 6.6 RELIABILITY TEST: CRONBACH'S ALPHA

In order to estimate the internal consistency and the reliability of factors, the questionnaire was subjected to the reliability test using Cronbach's alpha where coefficients were computed for each of the eight factors identified. The Cronbach's alpha value is a significant measure of the reliability and internal consistency among the constructs (Field, 2009). The Cronbach's alpha coefficients for the study are reported in Table 6.24.

**Table 6.24:** Descriptive statistics and internal consistency reliabilities

Item	N	Mean	SD	Corrected item-Total Correlation	Cronbach's Alpha if item Deleted	Total Cronbach's Alphas
<b>Transaction costs</b>						<b>0.720</b>
21a		9.42	3.860	0.557	0.627	
21b		9.88	4.073	0.470	0.683	
21c		8.32	4.663	0.538	0.656	
21e		10.23	3.931	0.498	0.666	
<b>Collateral</b>						<b>0.671</b>
25b		3.43	1.234	0.452	0.616	
25c		4.46	1.202	0.485	0.574	
25d		3.58	1.066	0.515	0.532	
<b>Lending technology</b>						<b>0.764</b>
16a		11.07	3.765	0.641	0.666	
16b		11.09	3.644	0.696	0.636	
16d		11.61	3.800	0.522	0.733	
16e		12.60	4.348	0.415	0.666	
<b>Creditworthiness</b>						<b>0.757</b>
18a		11.95	3.115	0.733	0.589	
18b		11.62	4.065	0.515	0.721	
18e		11.66	3.466	0.669	0.635	
18f		12.59	4.265	0.438	0.734	
<b>Bank-SME relationship</b>						<b>0.673</b>
24a		14.66	6.082	0.196	0.702	
24c		15.52	3.394	0.558	0.569	
24d		14.61	3.800	0.644	0.503	
24e		13.32	4.987	0.537	0.585	
<b>Innovative strategies</b>						<b>0.622</b>
28b		3.25	1.189	0.477	.	
28c		3.70	0.607	0.477	.	
<b>Credit supply</b>						<b>0.854</b>
6c		10.22	6.831	0.698	0.821	
6d		9.66	8.612	0.639	0.839	
6e		11.05	7.601	0.731	0.800	
6f		11.22	7.633	0.744	0.796	
<b>Risk management</b>						<b>0.632</b>
19a		13.70	0.867	0.352	0.531	
19b		13.55	0.927	0.337	0.544	
19c		13.00	1.011	0.277	0.595	
19d		12.90	1.055	0.319	0.565	

(Source: SPSS 23)

All scales have alpha coefficients between 0.622 and 0.854, which suggests high reliability. The factors from the principal components analysis are grouped into eight

categories: transaction costs, collateral, lending technology, creditworthiness, bank-SME relationship, innovative strategies, credit supply and risk management.

According to De Souza and Dick (2009), all coefficient alpha values of 0.6 are considered acceptable in statistical analysis. As shown in Table 6.24, there is a strong indication that the Cronbach's alpha that are recorded in this study are of acceptable range because the alphas of all the variables are above 0.6 (Gliem and Gliem, 2003). We can thus suggest that all the questionnaire items that are used in this study passed the reliability test.

In the subsequent section of this study, the researcher performed correlation and regression analysis to determine the associations between the dependent variable (credit supply) and independent variables (transaction costs, collateral, lending technology, creditworthiness, bank-SME relationship, innovative strategies and risk management). To assess the type of relationship, a regression analysis was done to determine whether the correlation is significant.

## **6.7 CORRELATION ANALYSIS**

Correlation indicates the strength and direction of a linear relationship between two random variables (Pallant, 2010) and is often measured as a correlation coefficient. The correlation coefficients between variables were determined for each of the constructs. Table 6.25 below indicates that all the factors had a p-value less than 0.05 ( $p < 0.05$ ) and a coefficient higher than 0.30, meaning that they were all correlated and that the relationship was significant. Details of the correlations are presented in Table 6.25.

**Table 6.25:** Pearson Correlation - Factors that influence credit supply to SMEs

Item	Factors	Credit supply	Transaction costs	Risk Management	Collateral	Lending technology	Creditworthiness	Innovative strategies	Bank-SME relationship
1	Credit supply	1							
2	Transaction costs	-.54 <sup>***</sup>	1						
3	Risk Management	-.11	.08	1					
4	Collateral	.23 <sup>*</sup>	.06	.14 <sup>*</sup>	1				
5	Lending technology	.56 <sup>***</sup>	-.40 <sup>**</sup>	-.00	.19 <sup>*</sup>	1			
6	Creditworthiness	-.63 <sup>***</sup>	.65 <sup>***</sup>	.21 <sup>*</sup>	-.07	-.35 <sup>**</sup>	1		
7	Innovative strategies	.46 <sup>**</sup>	-.40 <sup>**</sup>	-.18 <sup>*</sup>	-.03	.26 <sup>*</sup>	-.45 <sup>**</sup>	1	
8	Bank-SME relationship	.63 <sup>***</sup>	-.62 <sup>***</sup>	-.12 <sup>*</sup>	.18 <sup>*</sup>	.51 <sup>***</sup>	-.66 <sup>***</sup>	.44 <sup>**</sup>	1
***. Correlation is significant at the 0.01 level (2-tailed).									
**. Correlation is significant at the 0.05 level (2-tailed).									

This leads to the following hypotheses which addresses some of the research questions posed in chapter 1 for further analysis.

- H1 There is a significant correlation between transaction costs and credit supply to SMEs
- H2 There is a significant correlation between collateral and credit supply to SMEs
- H3 There is a significant correlation between lending technology and credit supply to SMEs
- H4 There is a significant correlation between creditworthiness and credit supply to SMEs
- H5 There is a significant correlation between bank-SME relationship and credit supply to SMEs
- H6 There is a significant correlation between lending technology and innovative strategy to SMEs
- H7 There is a significant correlation between innovative strategies and credit supply to SMEs

All the decision variables were significant and were therefore included for regression and structural equation modelling (SEM).

## 6.8 REGRESSION ANALYSIS

Regression is used for hypothesis testing, and is also referred to as the modelling of causal relationships (Pallant, 2010). Hence various regression techniques were used to analyse the possible relationships and the strength of the convergence.

### 6.8.1 Model Summary (Credit supply)

The output from the multiple regression analysis is shown in Tables 6.26 to 6.28. The overall multiple regression model is significant at the 95% level of significance with a p-value less than 0.05. The regression model summary indicates that adjusted R<sup>2</sup>-value = 0.560 which explains the variance of the model contribution which is above 50%. The p-value is less than 0.05 hence is significant as shown in Table 6.26. These results are acceptable, considering some of the previous results that are reported in similar studies on SME financing (Fatoki, 2012), or the R<sup>2</sup> value in social sciences in general (Pallant, 2005).

The Durbin Watson score was 1.812, for determinants of credit supply demonstrate that there are no auto correlation problems associated with the data used in this study. Two, is the “ideal” Durbin Watson measure of independence (See Table 6.26) (Hair et al., 2006). This indicates a high level of isolation among the independent variables of the model.

**Table 6.26:** Model Summary

Model	R	R Square	Adjusted R Square	Std. Error of the Estimate	Change Statistics					Durbin-Watson
					R Square Change	F Change	df1	df2	Sig. F Change	
1	.761 <sup>a</sup>	.579	.560	.55860	.579	30.510	7	155	0.000	1.903

a. Predictors: (Constant), CQ24, CQ19, CQ25, CQ28, CQ16, CQ22, CQ18  
b. Dependent Variable: CQ6

(Source: SPSS 23)

#### 6.8.1.1 Analysis of Variance (ANOVA)

The significance of adjusted R squared can be tested through the F-ratio and its associated probability. Meanwhile the F-value = 30.510, which is a ratio of the mean square for regression to the residual mean square (Pallant, 2010). The residual mean square indicates the difference between the actual value of the dependent variable, and the result of the regression equation (Tabachnik and Fidell, 2007). The

residual difference is significant, with a p-value equal to 0.000 which is significant as shown in Table 6.27. The regression and residual are calculated from all independent variables or predictors. The F-ratio has two degrees of freedom, one related to the number of independent variables used in the model, and the other based on sample size.

**Table 6.27:** Analysis of Variance

ANOVA						
Model		Sum of Squares	df	Mean Square	F	Sig.
1	Regression	66.641	7	9.520	30.510	.000 <sup>b</sup>
	Residual	48.365	155	0.312		
	Total	115.006	162			
a. Dependent Variable: CQ6						
b. Predictors: (Constant), CQ24, CQ19, CQ25, CQ28, CQ16, CQ22, CQ18						

The F-ratio is significant for further analysis using standardised coefficient regression.

#### 6.8.1.2 Standardised coefficient

The result of the variance inflation factor (VIF) analysis (Table 6.28) demonstrates that the VIF values for all the variables do not exceed the threshold generally accepted in the literature with values of 3.3 (e.g. Petter, Straub and Rai, 2007), which indicate that no multicollinearity problems exist with the variables.

Betas represent the importance of each variable in explaining the independent variable (Tabachnik and Fidell, 2007). Also the values represent the change in the dependent variable associated with the change in the independent variable. Depending on the t-values, the significance for the betas is shown in Table 6.45. The output from the multiple regression analysis is shown in Tables 6.43 to 6.45. The overall multiple regression model is significant at a 95% level of confidence with a p-value smaller than 0.05. The coefficient table shows how variables contribute to the model or equation. From the significance column, there are only four variables that make a statistically significant contribution (less than 0.05) (see Table 6.28). In order of importance they are SME financial status (beta is 0.298), lending technology (beta



is 0.283), collateral (beta is 0.148) and transaction cost (beta is -0.125). The corresponding VIF scores range from 1.074 to 22.567 (see Table 6.28).

**Table 6.28:** Standardised coefficient

Coefficients									
Model	Unstandardized Coefficients		Standardized Coefficients	t	Sig.	95.0% Confidence Interval for B		Collinearity Statistics	
	B	Std. Error	Beta			Lower Bound	Upper Bound	Tolerance	VIF
(Constant)	3.049	0.997		3.059	0.003	1.080	5.018		
Transaction costs	-0.160	0.099	-0.125	-1.625	0.106	-0.355	0.035	0.459	2.180
Collateral	0.325	0.126	0.148	2.567	0.011	0.075	0.574	0.816	1.225
Lending Tech	0.419	0.093	0.283	4.500	0.000	0.235	0.603	0.686	1.458
Creditworthiness	-0.434	0.116	0.298	3.735	0.000	-0.664	-0.205	0.426	2.345
Innovative strategies	0.177	0.067	0.163	2.655	0.009	0.045	0.309	0.721	1.387
Risk Management	-0.132	0.153	-0.047	-0.864	0.389	-0.433	0.170	0.931	1.074
BSMER	0.143	0.115	0.104	1.248	0.214	-0.084	0.370	0.390	2.567

a. Dependent Variable: CQ6

Source: SPSS 23

### 6.8.2 Model Summary (innovative strategies)

The regression model summary indicates that the adjusted  $R^2$ -value = 0.060. The p-value is less than 0.05 hence is significant as shown in Table 6.29. These results are acceptable, as discussed in section 6.5.4.1.

The Durbin Watson score was 1.641, for determinants of innovation strategy demonstrates that there are no auto correlation problems associated with the data used in this study. According to Hair et al. (2006) two, is the “ideal” Durbin Watson measure of independence (see Table 6.29). This indicates a high level of isolation among the independent variables of the model.

**Table 6.29: Model Summary**

Model Summary										
Model	R	R Square	Ad-justed R Square	Std. Error of the Estimate	Change Statistics					Durbin-Watson
					R Square Change	F Change	df1	df2	Sig. F Change	
1	.255 <sup>a</sup>	.065	.060	.78150	.065	12.704	1	182	.000	1.641
a. Predictors: (Constant), CQ16										
b. Dependent Variable: CQ28										

Source: SPSS 23

### 6.8.2.1 Analysis of variance (ANOVA)

The significance of adjusted R squared can be tested through the F-ratio and its associated probability. Meanwhile the F-value = 12.704, which is a ratio of the mean square for regression to the residual mean square (Pallant, 2010). The residual mean square indicates the difference between the actual value of the dependent variable, and the result of the regression equation (Tabachnik and Fidell, 2007). The residual difference is significant ( $p = 0.000$ ) as shown in Table 6.30. The regression and residual are calculated from all independent variables or predictors. The F-ratio has two degrees of freedom, one related to the number of independent variables used in the model, and the other based on sample size.

**Table 6.30: ANOVA<sup>a</sup>**

Model		Sum of Squares	df	Mean Square	F	Sig.
1	Regression	7.759	2	7.759	12.704	.000 <sup>b</sup>
	Residual	111.154	182	.611		
	Total	118.913	183			
a. Dependent Variable: CQ28						
b. Predictors: (Constant), CQ16						

### 6.8.2.2 Standardised coefficient

The result of the variance inflation factor (VIF) analysis (Table 6.31) demonstrates that the VIF values for all the variables do not exceed the threshold generally accepted in the literature with values of 3.3 (e.g. Petter, Straub and Rai, 2007), which indicate that no multicollinearity problems exist within the variables.

Betas represent the importance of each variable in explaining the independent variable (Pallant, 2005). Also the values represent the change in the dependent variable associated with the change in the independent variable. Depending on the t-

values, the significance for the betas is shown in Table 6.31. The output from the multiple regression analysis is shown in Tables 6.29 to 6.31. The overall multiple regression model is significant at a 95% level of confidence with a p-value smaller than 0.05. The coefficient table shows how variables contribute to the model or equation. From the significance column, there is only one variable that makes a statistically significant contribution ( $p = 0.000$ ) and a corresponding VIF score of 1.000 as shown in Table 6.31.

**Table 6.31: Coefficients**

Coefficients										
Model		Un-standardized Coefficients		Standardized Coefficients	t	Sig.	95.0% Confidence Interval for B		Collinearity Statistics	
		B	Std. Error	Beta			Lower Bound	Upper Bound	Tolerance	VIF
	(Constant)	2.219	.358		6.197	.000	1.512	2.925		
	Credit supply	.325	.091	.255	3.564	.000	.145	.505	1.000	1.000

a. Dependent Variable: CQ28 Innovative strategies

Source: SPSS 23

The causal relationships derived from the regression analysis are summarised in Table 6.32 below.

**Table 6.32: Factors that influence credit supply to SMEs by banks**

	Predictor	
H1	Transaction costs have a negative and significant influence on credit supply to SMEs	Supported
H2	Collateral has a positive and significant influence on credit supply to SMEs	Supported
H3	Lending technology has a positive and significant influence on credit supply to SMEs	Supported
H4	Creditworthiness has a negative and significant influence on credit supply to SMEs	Supported
H5	Bank-SME relationship has a positive and insignificant influence on credit supply to SMEs	Not Supported
H6	Lending technology has a positive and significant influence on innovative strategy	Supported
H7	Innovative strategies has a positive and significant influence on credit supply to SMEs	Supported

The correlation and regressions above have highlighted the presence of associations between credit supply and its predictor variables. These relationships have portrayed interrelationships among variables. These relationships are subjected to more robust analyses in order to eliminate any noises inherent in regression analysis and report a more robust result using structural equation modelling.

## **6.9 STRUCTURAL EQUATION MODELLING**

Structural Equation Modelling (SEM) was used to determine the main factors influencing supply of credit to SMEs by banks in South Africa. SEM was used to estimate all coefficients in the model in order to evaluate the significance and strength of the relationships within the model. This model has been adapted in previous studies such as Su and Yang (2010).

Both latent and observable variables are represented by the rectangular shape on the model as shown in figure 6.9. The constructs formed the latent variables while their indicators or metrics stood for the observable ones. Latent (silent) variables in SEM eliminate measurement errors leading to more valid coefficients being achieved. This is a common practice as demonstrated by Pallant (2010). As such an error term is appended to each observable variable. As shown in Figure 6.6, latent variables are connected to each other by two headed arrows that represent the covariance between the constructs. On the other hand, the observable variable of each construct connects to it by one-headed arrow that represents the causal path from the construct to the indicator.

One of the objectives of the study sought to determine the factors that influence the supply of credit to SMEs by banks in South Africa. Based on the estimated multiple regression equation of the ordinary least squares, the following hypothetical structural equation model (Figure 6.6) was derived and the covariance among the explanatory variables estimated. The dependent and explanatory variables are defined in Table 6.33 and the proposed model is shown in Figure 6.6.

**Table 6.33:** Definition of variables

Variable	Definition
TC	Transaction costs
C	Collateral
LTech	Lending technology
CW	Creditworthiness
BSMER	Bank-SME relationship
IS	Innovative strategies
RM	Risk management
CS (Dependent)	Credit Supply

According to figure 6.6, the proposed model hypothesises that credit supply (CS) is predicted by transaction costs (TC), collateral (C), lending technology (LTech), creditworthiness (CW), Bank-SME relationship (BSMER), innovative strategies (IS) and risk management (RM).

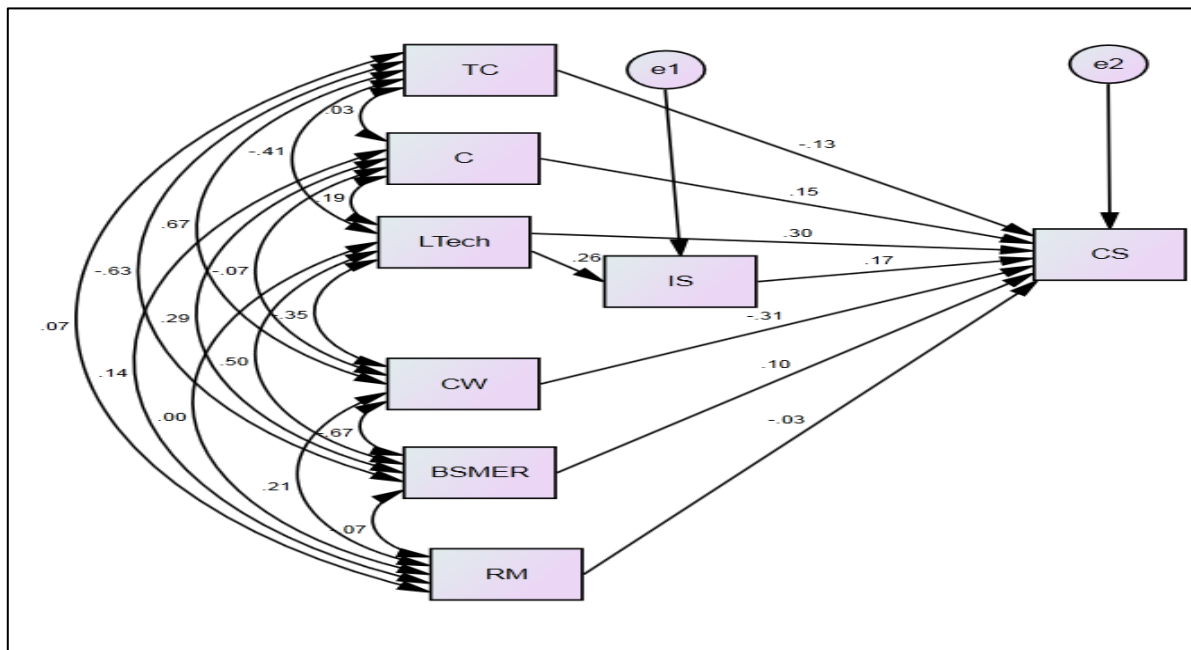

**Figure 6.6:** Proposed model for the determinants of credit supply.

Bank-SME relationship and risk management are observed to have the lowest predictive power of credit supply (0.10 and -0.3) respectively and are therefore excluded from further analysis.

### 6.9.1 Final Model generated through structural equation modelling (SEM)

After the preliminary analysis of the hypothesized model shown in Figure 6.9 above, the predictor variables transaction costs, collateral, lending technology, creditworthiness, innovative strategies and credit supply were retained. All the insignificant paths were dropped. The dependent and explanatory variables for the final model are defined in Table 6.34 below.

**Table 6.34:** Definition of variables in the final model

Variable	Definition
TC	Transaction costs
C	Collateral
LTech	Lending technology
CW	Creditworthiness
IS	Innovative strategies
CS	Credit supply
e1	Error term
e2	Error term

The final path diagram and parameter estimates for the model are shown in Figure 6.7 below.

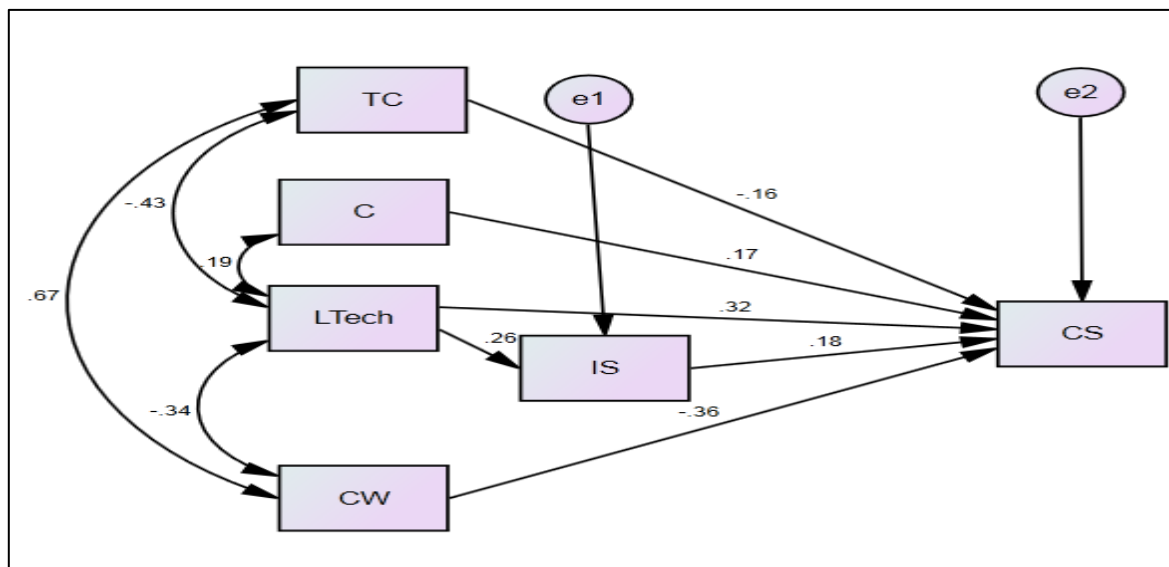

**Figure 6.7:** Determinants of supply of credit

Note: For each indicator an error term was appended. The error terms were arbitrary names with a term e and a numerical value. To indicate the relationships, double headed arrows were used to represent the covariance. The single-headed arrows were used to represent the causal relationship between decision variables. Rectangle shape indicates the constructs.

### 6.9.2 Maximum Likelihood estimates

As suggested by Dion (2008:366) the parameters are estimated by maximum likelihood (ML) methods rather than by ordinary least square (OLS) methods. According to Pallant (2010) OLS methods minimise the squared deviations between the values of the criterion variable and those predicted by the model. Also, Dion (2008) supports this position by observing that ML (an iterative procedure) attempts to maximise the likelihood that obtained values of the criterion variables are correctly predicted. Regression weights for the model variables were computed and presented in Table 6.35 below.

**Table 6.35:** Regression Weights: (Group number 1 – Default model)

			<b>Estimate</b>	<b>S.E.</b>	<b>C.R.</b>	<b>p</b>
Innovative Strategies	<---	Lending technology	0.328	0.091	3.608	0.000
Credit Supply	<---	Transaction costs	-0.174	0.098	-1.783	0.075
Credit Supply	<---	Collateral	0.258	0.093	2.778	0.005
Credit Supply	<---	Lending technology	0.419	0.080	5.240	0.000
Credit Supply	<---	Innovative strategies	0.183	0.054	3.365	0.000
Credit Supply	<---	Creditworthiness	-0.447	0.104	-4.308	0.000
Credit Supply	<---	Bank-SME relationship	0.140	0.108	1.298	0.194
Credit Supply	<---	Risk management	-0.086	0.144	-.599	0.549

Estimate = estimated path coefficient (prediction) for arrows in the model  
 Se = standard error  
 CR = critical ratio  
 P = probability value (<0.05 = significant at the 1% level \*\*\* [Garson, 2009]

### 6.9.3 Standardised regression weights

The path coefficients in Table 6.35 closely match those which are obtained from multiple regressions and are significant at the five percent error level, ranging from 0.000 to 0.075. Collateral, lending technology and innovative strategies were found to have a positive and significant relationship with the supply of credit ( $p < 0.05$ ). Transaction costs and creditworthiness had a negative and significant ( $p < 0.05$ ) influence on credit supply. However, the coefficient for transaction costs was (-0.174), indicating a significant negative influence on credit supply ( $p < 0.10$ ). It is observed that lending technology has the highest contribution to credit supply (.419 or approximately 42%). The contribution of the variable innovative strategies to credit supply (0.183), though significant, is observed to command the lowest direct effect. It

is interesting to note that bank-firm relationship ( $p=0.194$ ) and risk management ( $p=0.549$ ) have an insignificant relationship with credit supply, suggesting that they are not important predictors of SME lending.

Table 6.36 below shows the bidirectional correlations between dimensions and the simple correlations between exogenous variables (predictor variables). Most of them are significant, with the p-value ranging from 0.000 to 0.005.

**Table 6.36:** Co-variances: (Group number 1 – Default model)

			<b>Estimate</b>	<b>S.E.</b>	<b>C.R.</b>	<b>p</b>
Collateral	<-->	Risk management	0.274	0.037	7.473	0.054
Risk management	<-->	Lending technology	0.059	0.021	2.791	0.972
Creditworthiness	<-->	Risk management	-0.182	0.034	-5.432	0.006
Bank-SME relationship	<-->	Risk management	-0.013	0.014	-.940	0.347
Creditworthiness	<-->	Bank-SME r/s	-0.260	0.034	-7.553	0.000
Bank-SME relationship	<-->	Lending technology	0.201	0.033	6.131	0.000
Collateral	<-->	Bank-SME relationship	0.092	0.024	3.790	0.000
Transaction costs	<-->	Bank-SME relationship	-0.262	0.037	-7.145	0.000
Creditworthiness	<-->	Lending technology	-0.137	0.030	-4.534	0.000
Collateral	<-->	Creditworthiness	-0.022	0.023	-.969	0.333
Transaction costs	<-->	Creditworthiness	0.272	0.036	7.485	0.000
Collateral	<-->	Lending technology	0.059	0.024	2.509	0.012
Transaction costs	<-->	Lending technology	-0.171	0.033	-5.097	0.000
Transaction costs	<-->	Collateral	0.010	0.025	.415	0.678

Source: SPSS23

#### 6.9.4 Squared multiple correlations

**Table 6.37:** Squared multiple correlations: (Group Number 1 – Default model)

	<b>Estimate</b>
CQ28 Innovative strategies	0.067
CQ Credit supply	0.578



Finally, Table 6.37 above shows that about 58 percent of the credit supply model is explained by the predictor variables such as creditworthiness, collateral, innovative strategies and lending technologies as indicated in the model presented earlier in Figure 6.7. The squared multiple correlation coefficient gives the proportion of the variability in the item indicators, which is due to the respective latent construct; each having 0.067 for innovative strategies and 0.578 for credit supply. A high squared multiple coefficient ( $R^2$ ) implies that there is strong correlation between variables (Pallant, 2010).

### 6.9.5 Final model fit SEM using goodness of fit indices

In keeping with Hair et al. (2014), more robust tests were applied using the goodness of fit indices. Fit indices are used to inform the researcher how closely the data fit the model. Consequently, the analyses of the goodness of fit indices for the hypothesized model was done and the results are presented are shown in Table 6.38.

**Table 6.38:** Summary of the model evaluation regarding overall fit measurement

Index	Recommended value	Output	Remark
Likelihood ratio Chi Square (CMIN)	< 0.05	0.000	Very good
Goodness-Of Fit Index (GFI)	≥0.95 (not generally recommended)	1.000	Very good
Tucker Lewis Index (TLI)	≤ 1 (values close to 1 indicate a very good fit)	0.000	Good
Comparative Fit Index (CFI)	≤ 1 (values close to 1 indicate a very good fit)	1.000	Very good
Root Mean Square Error of Approximation (RMSEA)	<0.05 to 0.08 with confidence interval	0.214	Insignificant, therefore poor model fit
Normed Fit index (NFI)	≤1 (values close to 1 indicate a very good fit); indices < 0.9 can be improved substantially.	1.000	Very good

Source: SPSS 23

As shown in Table 6.38, the measurement model test presented a good fit between the data and the proposed measurement model. Almost all the indices confirm that all the sample data fit the model significantly. Only the root mean square error of

approximation (RMSEA) showed a poor model fit. However, as the majority of indices confirmed a good model fit, results of the RMSEA index were discarded. PCLOSE is the p-value which tests whether the null hypothesis of the RMSEA is less than 0.05. Consistent with Hair et al. (2014) it was concluded that the model fits the data being tested. Therefore, the hypothesized structural model for this study is validated and accepted.

Following on the above observation, it can be concluded that the model fits the data well and the next step is to consider the causal paths of the model. The path coefficients in the SEM model represent the unstandardized regression coefficients. Properties of the causal paths (unstandardized path coefficients ( $\beta$ ), standard error of regression weight, probability values and hypotheses result) are shown in Table 6.39 and 6.40 respectively. Unstandardised coefficients describe the association between credit supply and one unit change in the other variables. From Table 6.39, it is shown that one unit increase in lending technology leads to about 42% increase in credit supply.

**Table 6.39:** The unstandardized regression weights and the corresponding probability values

Construct	Path	Construct	Unstandardised Path coefficients ( $\beta$ )	Standard Error of Regression Weight	Probability	Hypothesis Result
Credit supply	<---	Transaction costs	-0.174	0.098	0.075	Reject $H_0$ at $\alpha = 0.10$
Credit supply	<---	Collateral	0.258	0.093	0.005	Reject $H_0$ at $\alpha = 0.05$
Credit supply	<---	Lending technology	0.419	0.080	0.000	Reject $H_0$ at $\alpha = 0.05$
Credit supply	<---	Innovative strategies	0.183	0.054	0.000	Reject $H_0$ at $\alpha = 0.05$
Credit supply	<---	Credit-worthiness	-0.447	0.104	0.000	Reject $H_0$ at $\alpha = 0.05$
Credit supply	<---	Bank-SME relationship	0.140	0.108	0.194	Fail to reject $H_0$ at $\alpha = 0.05$
Credit supply	<---	Risk Management	-0.086	0.144	0.549	Fail to reject $H_0$ at $\alpha = 0.05$
Innovative strategies	<---	Lending technology	0.328	0.091	0.000	Reject $H_0$ at $\alpha = 0.05$

Source: SPSS 23

Table 6.40 below presents a summary of the results of the hypotheses that have been tested through the use of the structural equation modelling technique.

**Table 6:40:** The result of the hypothesis testing

Hypothesis	Hypothesis statement	Result
H <sub>1</sub>	Transaction costs has an influence on credit supply	Supported
H <sub>2</sub>	Collateral has an influence on credit supply	Supported
H <sub>3</sub>	Lending technology has an influence on credit supply	Supported
H <sub>4</sub>	Innovative strategies has an influence on credit supply	Supported
H <sub>5</sub>	Creditworthiness has an influence on credit supply	Supported
H <sub>6</sub>	Bank-SME relationship has an influence on credit supply	Not supported
H <sub>7</sub>	Risk Management has an influence on credit supply	Not supported
H <sub>8</sub>	Lending technology has an influence on innovative strategies	Supported

This study is concerned with an empirical investigation of factors that could affect credit supply to SMEs in the Gauteng province of South Africa. The hypothesised structural model indicates that credit supply confirms a good model fit.

The results of this study have revealed that a new credit supply model (see Figure 6.7) can be compiled that would explain the factors that could influence the supply of credit to SMEs. As shown in Table 6.55 transaction costs ( $\beta = -0.174$ ,  $p = 0.075$ ) and creditworthiness ( $\beta = -0.447$ ,  $p = 0.000$ ) were found to have a negative and significant influence on credit supply. This implies that credit supply to SMEs decreases with increasing transaction costs associated with SME loan administration increases. This result is in line with the findings of Khan and Hussain (2011) who found transaction costs to have a negative influence on credit demand. This result is also consistent with the findings of Stiglitz and Weiss (1981) which indicate that credit supply decreases with increasing transaction costs due to information asymmetry. On the other hand, collateral ( $\beta = 0.258$ ;  $p = 0.005$ ), lending technology ( $\beta = 0.419$ ;  $p = 0.000$ ), and innovative strategies ( $\beta = 0.183$ ;  $p = 0.000$ ) were found to have a positive and significant influence on credit supply; whereas bank-SME relationship ( $\beta = 0.140$ ;  $p = 0.194$ ) and risk management ( $\beta = 0.381$ ;  $p = 0.549$ ) were reported to

have insignificant influences on credit supply. Bank-firm relationship was observed to be positive and insignificant, suggesting that it is a vital factor in the supply of credit to SMEs.

Lending technology is the most significant predictor ( $\beta = 0.419$ ) which influences credit supply in this study. Therefore, software technology makers and banks must focus on producing software that can easily be integrated and is compatible with the SMEs legacy. Easy integration is the key to determine whether a SME will adopt the new technology or vice versa. As a recommendation, a detailed descriptive research should be done in order to assess the credit supply level of the banks before identifying the predictors of credit supply.

These results suggest that banks need to concentrate more on improving the lending technologies in order to improve credit supply to SMEs. However, lending technology has a significant indirect effect on credit supply through innovative strategies as shown in Figure 6.7. This implies that banks have to use innovative strategies such as correspondent banking and psychometric testing in order to reach as many SMEs as possible. These results concur with those of Chironga et al. (2012), Stephanou and Rogriguez (2008) which were dealt with in Chapter 3.

## **6.10 SUMMARY OF THE RESULTS FOR THE BANK SURVEY**

The chapter reported and analysed the results from the empirical research. The descriptive statistics relating to each question of the questionnaire were presented, wherein the frequencies were described. Taking into account the weaknesses of the descriptive statistics, factor analysis, correlation, regression and structural equation modelling (SEM) methods were employed for robustness.

The majority of the banks were observed to be involved with SMEs to a very large extent with most of them having separate SME units responsible for SME relations. The study also revealed that the perceived profitability of the SME segment is the most important driver of the banks' involvement with SMEs. Despite their interest in getting involved with SMEs, banks are faced with a number of challenges that deter them from funding SMEs. The challenges include macroeconomic, bank specific and firm-specific factors. Consequently banks have to manage the credit risk associated

with SME lending in order to maximise the return while maintaining the operational risks at a minimum (Moosa, 2007).

Supply of credit was found to be a function of transaction costs, collateral, lending technology, creditworthiness and innovative strategies. However, bank-SME relationship and risk management were found to have an insignificant influence on credit supply. It can therefore be concluded that the chapter has demonstrated the endogenous and exogenous variables in the credit supply function by banks. The following section gives an analysis of results based on the SME questionnaire.

## **PART TWO: ANALYSIS OF THE RESULTS OF THE SMEs SURVEY**

### **6.11 INTRODUCTION**

As suggested by the literature, if SME access to finance is improved, this sector of the economy will be able to contribute more meaningfully to economic development and job creation in a country where almost a quarter of the total population is unemployed. The study aimed at uncovering the challenges that are confronted by SMEs and the factors that influence the SME access to bank finance. This section presents the findings of the questionnaire with reference to the SMEs survey. The overall objective of the SME survey was to shed some light on the problems and dilemmas associated with SME financing as perceived by the SMEs. Therefore, the results of the analysis should be seen as complementary to the conclusions drawn from the bank survey. The sixth objective of the study was to determine the challenges faced by SMEs in accessing bank finance. The seventh objective was to determine the factors which influence the access of bank credit by SMEs in South Africa. The next section presents the findings of the analysis of the SME survey.

### **6.12 CHARACTERISTICS OF THE SAMPLE**

A total of 262 SMEs owners/managers participated in the study out of an intended target of 400 respondents. The response rate was 65.5% which was an acceptable response since it was a self-administered questionnaire. According to Leedey and Ormrod (2010), the response rate of questionnaires is sometimes low, even below 50%. To that extent, the response rate for this study passes the basic requirement and it is thus considered a statistically good response rate. The socio-demographic information of the sample is presented in Table 6.41.

**Table 6.41:** Characteristics of the SMEs respondents in the sample

<b>VARIABLE</b>	<b>CATEGORY</b>	<b>F</b>	<b>%</b>
Gender	Male	148	56.5
	Female	114	43.5
	Total	262	100.0
Age in years	Below 30 years	82	31.3
	30 – 39 years	63	24.0
	40 – 49 years	75	28.6
	50 – 59 years	38	14.5
	60 years and above	4	1.5
	Total	262	100.0%
Level of education	None	5	1.9
	Standard 8/ Grade 10	23	8.8
	Standard 9/ Grade 11	12	4.6
	Standard 10/ Grade 12	53	20.2
	Diploma/certificate	78	29.8
	Professional (e.g. CA)	11	4.2
	University degree	52	19.8
	Post graduate degree	28	10.7
	Total	262	100.0
Ownership of business	Inherited from family	31	11.9
	Formed the business (started from scratch)	190	72.8
	Bought the business	31	11.9
	Franchise	9	3.4
	Total	261	100.0
Length of business in operation	At most a year	39	14.9
	2 - 3 years	65	24.9
	4 – 5 years	53	20.3
	6 – 10 years	58	22.2
	More than 10 years	46	17.6
	Total	261	100.0

### **6.12.1: Gender**

The respondents were asked to indicate their gender. This had a dual purpose; firstly, to determine whether there was a gender balance in the sector and secondly, to establish the influence, if any, of gender on the access of bank finance. As shown in Table 6.20, all respondents indicated their gender. About 56.5% (n=148) of the respondents were males whilst 43.5% (n=114) were females (n=32; 41.0%). Thus the ratio of males to females was almost 3:2.

The response shows that the SME industry in Gauteng is dominated by males. According to GEM (2010) the ratio of male to female participation in the SME sector may reflect the impact of culture and customs regarding female participation in the economy. This may also be an indication that more males are resorting to starting their own businesses in an effort to create employment.

### **6.12.2 Age of the entrepreneur**

In terms of age, 31.3% (n=82) of the respondents were below 30 years whilst 24 % (n=63) were between 30-39 years. It can be concluded that the majority of the respondents were below 40 years of age. This is normally the active workforce age group. Only 1.5% (n=4) are 60 years and above. It can be deduced that the need to start and operate a business tends to reduce with age. According to GEM (2010), increased entrepreneurial activity is an indication of a maturing entrepreneurial population in South Africa, who regard entrepreneurship as a career of choice. GEM (2010) further affirms that men in South Africa are 1.5 times more likely to be involved in entrepreneurial activities than women. Therefore, it can be safely concluded that the results of this study are a true reflection of the situation in South Africa.

### **6.12.3 Educational level**

According to the GEM (2010) education increases an individual's belief in starting a business and the possibility that the business will survive beyond the start-up phase. It is therefore important to understand the education levels of SME owner managers. Respondents were therefore asked to indicate their level of education. Close to 30% of the respondents have either a university degree or post graduate degree. Those with a diploma or a professional course were 34% while 64.5% of the respondents had tertiary qualifications. This observation may be attributed to the increasing



unemployment rate in South Africa. Due to the high level of unemployment, more graduates are turning to self-employment through the establishment of their own businesses. This is contrary to the traditional belief that SME operators are assumed to be those with no education.

#### **6.12.4 Business Ownership**

The majority of the respondents, that is, 72.8% indicated that they started their own businesses as entrepreneurs, whilst 11.9% inherited from family and the same proportion bought the business. A minority obtained their businesses through the Industrial Development Corporation (IDC). It can therefore be concluded that the majority of the participants started their business thus, in a way, alleviating the unemployment problem in South Africa.

#### **6.12.5 Age of the Enterprise**

The survey also sought to determine the age of the enterprises that were included in the sample. This was essential because enterprise age influences the use of different sources of financing, and hence the capital structure. In terms of the number of years in business, the largest proportion of 24.9% has been in existence for 2 – 3 years whilst 14.9% have been in business for at most a year. Thus 40% of the enterprises have been in existence for almost 3 years. The distribution of age of the business is almost normally distributed. About 22% of the respondents suggest that their businesses have been operating for between 6 and 10 years, whilst 17.6% of the enterprises are older than 10 years. It is believed that the reputational capital held by older firms is sufficient to ensure that the risk of default of the bank credit is minimized.

#### **6.12.6 Economic sector**

Some of the SMEs tend to be involved in more than one sector of the business. These are some of the strategies used by SMEs for survival in such a way that if one sector collapses then the other sector will still be viable. There were 257 participants who indicated the sector(s) they operated in.

**Table 6.42:** Economic sector SMEs are operating in

<b>Provider</b>	<b>Frequency</b>	<b>%</b>	<b>Rank</b>
Finance, real estate and business services	67	26.1	1
Wholesale, retail trade, hotels and restaurants	56	21.8	2
Transport, storage and communications	44	17.1	3
Manufacturing	25	9.7	4
Electricity, gas and water	24	9.3	5
Agriculture, forestry and fishing	23	8.9	6
Construction	16	6.2	7
Mining and quarry	8	3.1	8

Based on Table 6.42, the largest proportion of SMEs are in the finance, insurance, real estate and business services sector (26.1%), wholesale, retail trade, hotels and restaurants (21.8%) and transport storage and communications (17.1%). These are the sectors where the bank employee participants indicated that the funding has not increased. In comparison, the results of the bank questionnaire showed that the top most sectors where there had been an increase in loan approval was agriculture, forestry and fishing, and electricity, gas and water. It therefore means that most of the SMEs are not operating in the prioritised sectors for bank loans.

However, the results concur with those of the bank survey in that fewer firms operate in the mining and construction sectors, possibly due to the volatility sparked by labour strikes in these industries in recent years. The same findings are echoed by Drakos and Giannakopoulos (2012) who determined that firms operating in the mining sector in Italy witnessed the highest credit rationing. According to Musara and Fatoki (2012), SMEs in the Gauteng province contribute 52 - 57 percent to gross domestic product (GDP) at provincial level, and provide 61% of employment and 36% on GDP at national level. This affirms the importance of SMEs towards South Africa's economic growth.

### 6.12.7 Enterprise size

Enterprise size has been viewed as a determinant of a business' capital structure. Several reasons have been put forward to justify this assertion. Firstly, smaller enterprises find it costly to resolve information asymmetry problems with potential lenders, resulting in limited access to finance. Consequently they face higher transaction costs and interest rate charges, and this discourages the use of external financing. According to Berger and Udell (1998), such effects are more predominant among SMEs because they are more informationally opaque than large enterprises. For this study, size is measured using the number of employees as operationalized in section 1.2.5.

The empirical results indicate that the minimum number of employees was one and the maximum was 54. It can be noted that there are SMEs where the owner is the only employee. Thus on the average, the SMEs have nine employees. The distribution of the number of employees is shown in Figure 6.8.

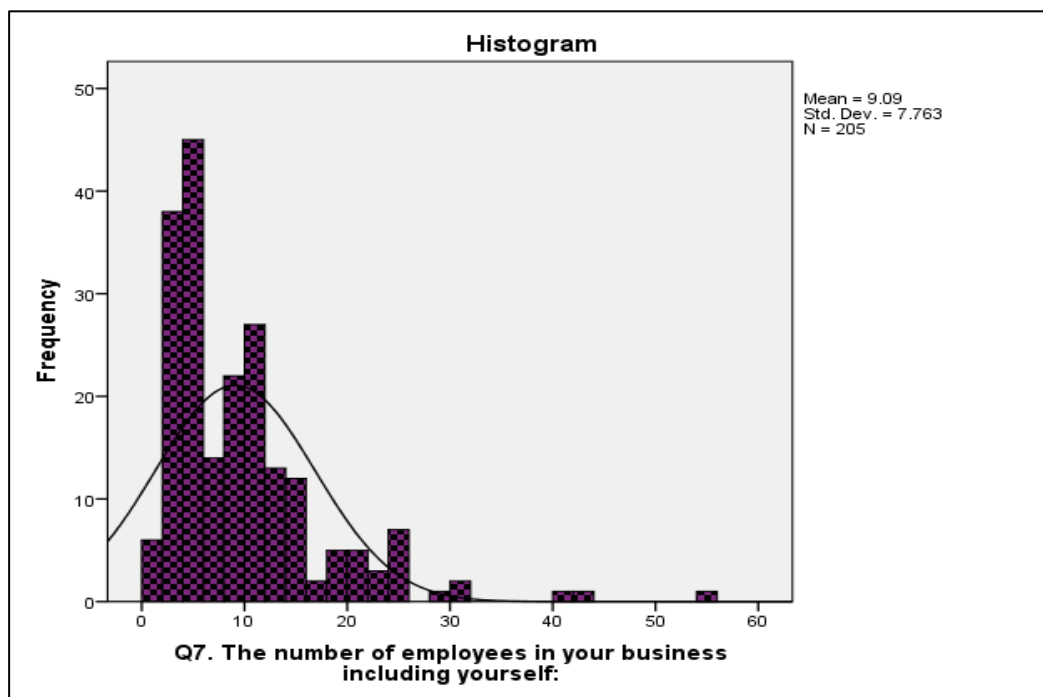

**Figure 6.8:** The number of employees in the business

As shown in Figure 6.8 approximately 50% of the SMEs have an average of nine employees in their organization. The standard deviation was 7.763 giving a coefficient variation of 78.41%. One can conclude that 68% of the SMEs employ between one and sixteen workers. The distribution of employees is positively

skewed as depicted in the histogram in Figure 6.8. Based on the average number of people employed by the SMEs in the sample, it can be concluded that the majority of the SMEs are small and would find it difficult to access external financing.

### 6.12.8 The classification of the enterprises

The respondents were asked to indicate the classification of their businesses. The purpose was to determine the relationship between the entrepreneurial classification of the businesses and access of these businesses to bank finance. The empirical survey found that the majority of the enterprises were private companies (43.2%) while 35% were close corporations as shown in Figure 6.9.

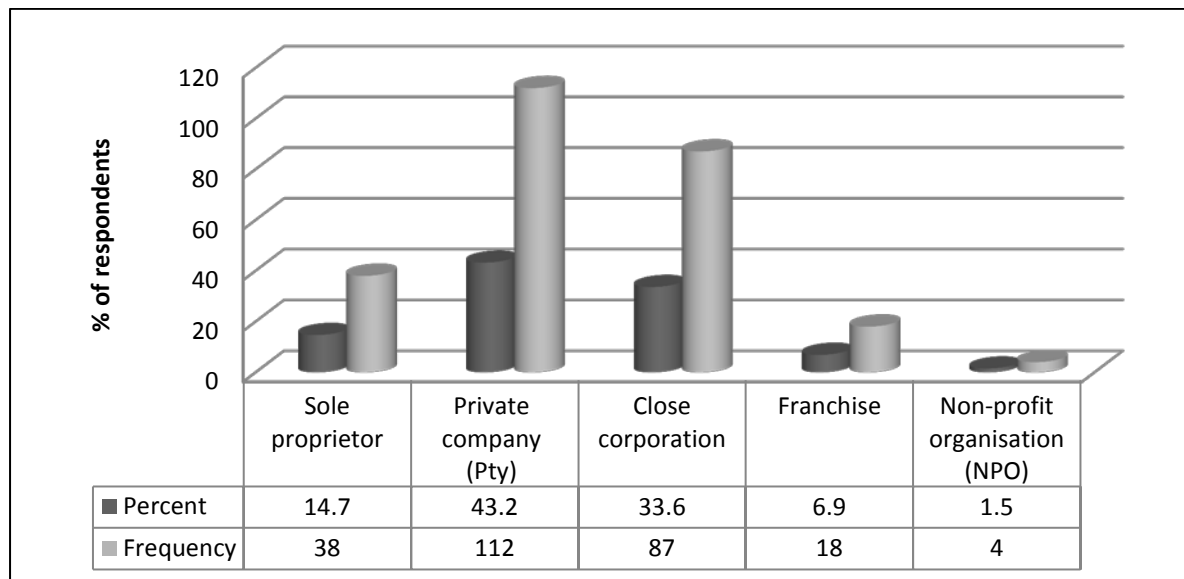

**Figure 6.9:** The classification of the enterprises

One can conclude that in terms of classification of a SME, some of the businesses are either private companies or close corporations. The number of private companies being registered is increasing due to the implementation of the new Companies Act 71 of 2008 which calls for the phasing out of the close corporations with effect from 1 May 2011. The new Act also made provision for the conversion of Close Corporations to private companies without cost. The more formal the SME, the greater its potential to contribute to the economy.

In addition, the postulated effect of the legal form of business on financing is related to the extent that it affects the availability of particular forms of financing. Storey (1994) argues that while some may consider the benefits of limited liability as the critical decision in the choice of legal form of the business, the limited liability gain is fictitious in reality (Migiro, 2005). Based on the argument above, banks may perceive incorporation as a good signal of credibility and formality of operations. It further serves as an indicator of growth potential. For example, Coleman and Cohn (2000) found evidence suggesting a positive relationship between leverage and incorporation. It may therefore be argued that since this form of business utilizes bank finance more efficiently, SMEs are therefore at an advantageous position to access bank financing.

### **6.13 FINANCIAL INFORMATION**

The choice of lending technology determines the availability and cost of finance for SMEs which consequently influences the firm's investment policy and ultimately the overall performance. In order to get views on SME access to finance, the owners/managers were asked to give their financial information and opinion on their experiences with the financial institutions. The next section reports on the findings pertaining to bank-SME relationships.

#### **6.13.1 Bank-SME relationship**

Close to 256 respondents indicated the banks they had a relationship with. As indicated in Table 6.43, about 50.4% of the respondents bank with the Amalgamated Banks of South Africa (ABSA), 41% with Standard bank South Africa, 32% with First national Bank (FNB) and 29% with Nedbank.

Thus, most of the SMEs have banking relationships mainly with the commercial banks of South Africa namely ABSA, Standard Bank of South Africa, First National Bank (FNB) and Nedbank. A few also deal with Investment banks (7.4%) and Post banks (4.7%). The results in Table 6.43 are an indication that commercial banks are still the financial institutions of choice for external financing for the sampled SMEs. Commercial banks have a competitive advantage over small banks in terms of size, value of assets and geographic distribution. It can be argued that although SMEs

have difficulty in accessing bank finance, they still look up to commercial banks for their financing needs.

**Table 6.43:** Bank-SME relationship with

<b>Provider</b>	<b>Frequency</b>	<b>%</b>	<b>Rank</b>
ABSA	129	50.4	1
Standard Bank South Africa	106	41.4	2
FNB	82	32.0	3
Nedbank	74	28.9	4
Investment banks e.g. Investec	19	7.4	5
Saving banks e.g. Post Office	12	4.7	6
Development banks e.g. Land bank	3	1.2	7
Micro Finance Institutions	1	0.4	8
Capitec	1	0.4	9

### 6.13.2 Duration of bank-firm relationship

The respondents were asked to indicate the duration they had maintained an account with their main bank. This information was important in order to determine whether a long relationship with one bank would enable the bank managers to understand the business of their clients and hence advance the required credit accordingly. According to the empirical results, the largest proportion, that is 25.1% had maintained an account with their main bank for a period between 2-3 years, followed by 4-5 years (23.2%) and 18.5% for 6-10 years and above shown in Table 6.44.

**Table 6.44:** Duration of bank-SME relationship

<b>Period</b>	<b>Frequency</b>	<b>%</b>	<b>Rank</b>
At most a year	38	14.7	1
2 -3 years	65	25.1	2
4 – 5 years	60	23.2	3
6 – 10 years	48	18.5	4
More than 10 years	48	18.5	5
	<b>233</b>	<b>100.00</b>	

The distribution of the duration of the relationship with the bank is also in line with the number of years the business has been operating. It might be suggesting that most of the SMEs have kept an account with one bank since the business inception. The results therefore suggest low bank mobility (SMEs maintain stable relationships with their main bank) among SMEs in the study. Theory suggests that SMEs that form long relationships with a principal bank secure several advantages, including lower interest costs, greater credit availability, lower collateral demands, and protection against credit rationing during periods of financial distress (Drakos and Giannakopoulos, 2012).

According to Diamond (1989:4), bank-firm relationships enhance reputation. The reputation of a firm may be measured as a function of variables such as firm age and the duration of the relationship with the main bank. A positive relationship may be expected between a long bank-SME relationship and access to finance.

### 6.13.3 Sources of finance

There were 255 respondents who indicated their source of finance for their businesses. The question was a multiple response where some respondents gave more than one source of finance. The information is shown in Table 6.45.

**Table 6.45:** Sources of SME finance

Source	Frequency	%	Rank
Personal savings	157	61.6	1
Loans from family/friends	106	41.6	2
Trade credit	99	38.8	3
Bank finance (overdraft, loans and credit cards)	83	32.5	4
Retained earnings	32	12.5	5
Leasing or hire purchase	27	10.6	6
Equity (shares, venture capital, business angels)	24	9.4	7
Microfinance (loan sharks)	14	5.5	8
Government guarantee scheme	7	2.7	9
Factoring (discounting of debts)	1	0.4	10

The results from Table 6.45 show that the most commonly used source of financing was personal savings (61.6%) followed by loans from family/friends (41.6%), trade credit (38.8%) and bank financing with 38.8% of the responses. This finding is consistent with previous research such as Migiro (2005) in Kenya, Akuetteh (2009) in Ghana, and Fatoki (2010) in South Africa. The findings are also consistent with those from developed countries (see section 3.4.1). For example in the US, 47% of small businesses relied on personal savings to finance their businesses. The results show that there is an increasing use of trade credit in an effort to close the financial gap created by the constrained access to bank finance. Only 9% of the respondents have access to equity finance due to the high trading requirements. However, most SMEs cannot meet these requirements as discussed in section 3.4.2.

Bank finance, comprising of bank loans, overdraft and credit card, was cited by 32.5% of the respondents as a source of finance for their business. The low use of bank loans is a result of information asymmetry which is higher with respect to small businesses (Stiglitz and Weiss, 1981). SMEs are unable to provide collateral as security for their loan applications (Bhaird and Lucey, 2008), and also lack credit history and business experience (Green, 2003).

#### **6.13.4 Access to finance**

The study also sought to establish financial information relating to the access to bank finance as discussed below.

##### **6.13.4.1**      *Number of loans received*

The respondents were asked to indicate the number of loans they had accessed in the past three years. About 57.4% of the respondents applied for a bank loan whilst 42.6% did not apply at all. Of those who applied, 59.9% had their loan applications approved whilst 40.1% had their applications rejected. Figure 6.10 below shows the number of bank loans received in the last three years.



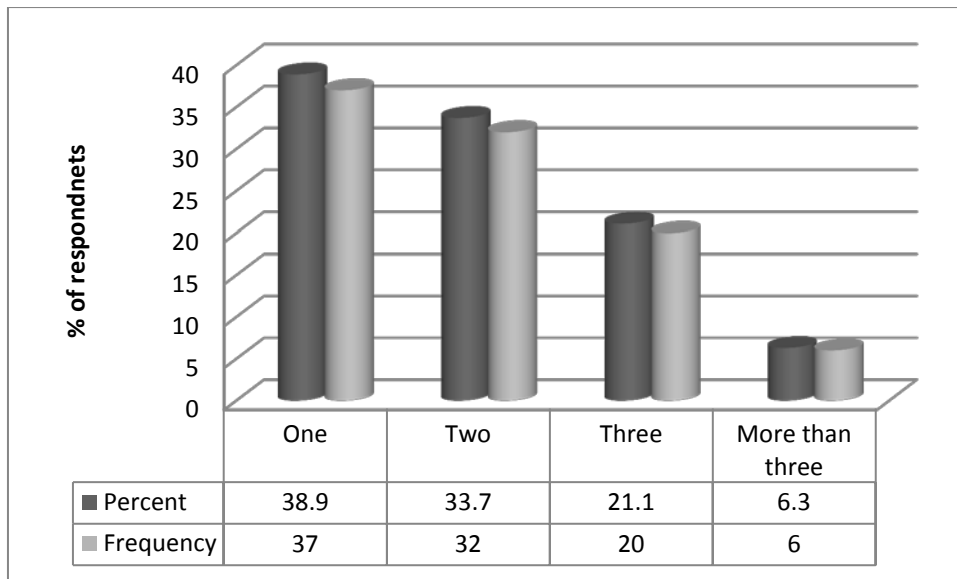

**Figure 6.10:** Number of loans received in the last three years

As shown in Figure 6.10, a large proportion of respondents either got one (38.9%) or two (33.7%) loans over the past three years. Only 6.3% received more than three loans. However, most respondents indicated that bank finance was mainly short-term in the form of credit card facility and bank overdraft.

#### 6.13.4.2 *Type of loans held with the main bank*

The respondents were asked to indicate the type of loans they have with their main bank. The results of the multiple response questions are presented in Table 6.46. The majority of the respondents tend to have a bank overdraft or credit card facility with the main bank. Close to half also have long term loans and almost 40% tend to have short-term loans and medium-term loans. The findings imply that most SMEs make use of short-term credit from the banks because it usually does not require collateral. Most of these short-term loans are unsecured, hence the interest rate charged on these loans is high (NCR, 2011).

**Table 6.46:** Type of loan sourced from main bank

Type of loan	Frequency	% of cases	Rank
Bank overdraft	73	64.0	1
Credit card	66	57.9	2
Long-term loans (over 5 years)	52	45.6	3
Short-term loans (up to 1 year)	47	41.2	4
Medium-term loans (1 - 5 years)	41	36.0	5
None	19	6.4	6

#### 6.13.4.3 *Collateral*

Previous studies on the relationship between collateral and access to bank finance have indicated that a lack of collateral to the satisfaction of the banks is a constraint to SMEs seeking external finance, particularly bank credit. It has also been established that the mismatch between supply and demand in the financial market is partly a result of lack of collateral (Stiglitz and Weiss, 1981; Levy, 1993). The results from the study indicate that collateral is a prerequisite for SMEs to access bank finance as shown in Table 6.47. The respondents were asked to indicate the extent to which they used property and investments, personal assets and accounts receivable as collateral to secure their bank loans. The categories to a “very large extent” and “to a large extent” were combined to give the rankings in Table 6.47.

Table 6.47 shows that very few SMEs make use of property and investment (9.6%), personal assets (8.3%) or accounts receivable (8.0%) as collateral. These are the types of collateral requested by the banks as security for loans taken. The findings imply that the majority of SME operators do not have sufficient collateral required by the bank as security against the loan applications. According to Drakos and Giannakopoulos (2012), collateral pledged by borrowers may help mitigate the problem of adverse selection faced by the banks when lending to SMEs. This could be a result of opaque information that characterises small businesses.

**Table 6.47:** The extent of use of collateral to source bank loans

Statement	Level of Extent				Sample Size	Rank
	To a very large extent and to a large extent	To some extent	To a little extent	No to an extent at all		
Property and investments	9.6% (8)	8.4% (7)	14.5% (12)	67.5% (56)	83	1
Personal assets of owner (e.g. house)	8.3% (7)	18.8% (16)	27.1% (23)	45.9% (39)	85	2
Accounts receivable (e.g. government contract)	8.0% (7)	21.8% (19)	33.3% (29)	36.8% (32)	87	3

These findings corroborate those of Van Aardt Smit and Fatoki (2012) in South Africa and the problems of information asymmetry can thus be mitigated through the pledging of collateral by the borrower so as to secure credit facility. This also confirms the findings by De la Torre, Martinez Peria and Schmukler (2010) that collateral reduces information asymmetry between the SME and the lender.

#### 6.13.4.4 *Reasons for rejection of loan application*

The respondents were further asked to indicate the reasons for the rejection of their loan applications. The scale items “to a large extent” and “to a very large extent” were combined to give the rankings in Table 6.48.

**Table 6.48:** Reasons for the rejection of SME loan applications

Statement	Level of Extent				Sample Size	Rank
	To a very large and to a large extent	To some extent	To a little extent	No to an extent at all		
Lack of collateral	84.1% (43)	7.9% (5)	3.2% (2)	4.8% (3)	63	1
Lack of contribution towards the project	82.6% (52)	9.5% (6)	-	7.9% (5)	63	2
Inadequate credit history of the firm	77.0% (50)	13.8% (9)	1.5% (1)	7.7% (5)	65	3
Inability to repay the loan	65.1% (41)	19.0% (12)	4.9% (3)	11.1% (7)	63	4
Poor credit record of applicant(s)	58.5% (38)	9.2% (6)	10.8% (7)	21.5% (14)	65	5
No relationship with the bank	54.1% (33)	31.1% (19)	1.6% (1)	13.1% (8)	61	6
Lack of comprehensive business plan	34.9% (22)	46.0% (29)	7.9% (5)	11.1% (7)	63	7
Non-compliance with the National Credit Act (NCA)	-	46.2% (30)	29.2% (19)	15.4% (10)	65	8
Project evaluated by bank as too risky	6.2% (4)	12.5% (8)	3.1% (2)	78.1% (50)	64	9
Lack of profitability of the firm	-	3.2% (2)	6.5% (4)	85.5% (53)	62	10

Table 6.48 indicates that the main reason for rejection of loan applications is the lack of collateral (84.1%), followed by lack of owner contribution towards the project (82.6%), inadequate credit history of the firm (77%), inability to repay the loan (65.1%), and lack of a relationship with the bank (54.1%). Other factors include lack of comprehensive business plans (34.9%) and projects being evaluated as too risky by the banks (6.2%). Lack of profitability was considered not to be important at all (85.5%) by the majority of the SMEs. It can thus be concluded that lack of collateral is the main reason for the rejection of SME loan applications by banks. These results are consistent with those of Akuetteh (2009) in Ghana and Newman (2010) in China. For the SMEs, non-compliance with the National Credit Act (NCA) is not an important reason for the rejection of their loan applications.

These findings are in line with those of the bank survey except for the issue of relationship with the bank. 54.1% of the SMEs were of the opinion that bank-SME relationship influences their access to bank credit whereas only 16.5% of the bank respondents indicated that a lack of banking relationship might contribute to a loan being rejected.

#### 6.13.4.5 *Reasons for not currently having a bank loan*

For the respondents who had not applied for a loan, the study sought to determine the reasons for not doing so. The results of the analysis are shown in Table 6.49.

**Table 6.49:** Reasons for not currently having a loan with bank

<b>Period</b>	<b>Frequency</b>	<b>%</b>	<b>Rank</b>
Our firm did not apply for a loan	118	69.4	1
Our application was turned down	50	29.4	2
Our application for the loan is still pending	2	1.2	3
	<b>170</b>	<b>100.00</b>	

From Table 6.49 it can be observed that the largest proportion of SMEs (69.4%) indicated that their firm did not apply for a loan, 29.4% had their loan applications declined whilst only 1% of the respondents had pending loan applications. This result indicates evidence of self-credit rationing as the majority of the SMEs did not apply for a loan possibly due to fear of rejection and lack of collateral. Similar findings have been established by Kundid and Ercegovac (2011) in Croatia and Akuetteh (2009) in Ghana.

For the respondents who had not applied for a bank loan, the study sought to determine the reasons for not applying. Research results indicated five main reasons why respondents would not apply for a loan. Scale items “to a very large extent” and “to a large extent” were grouped together to make up the rankings indicated in Table 6.50 below.

**Table 6.50:** Reasons for not applying for a bank loan

Statement	Level of Extent				Sample Size	Rank
	To a very large and large extent	To some extent	To a little extent	No to an extent at all		
High interest rates	80.4% (86)	10.3% (11)	1.9% (2)	7.5% (8)	107	1
Lack of collateral	74.2% (79)	16.8% (18)	2.8% (3)	6.5% (7)	107	2
Application procedures are too burdensome	47.6% (50)	38.1% (40)	1.9% (2)	12.4% (13)	105	3
Discouraged by bank requirements	46.2% (50)	22.2% (24)	4.6% (5)	26.9% (29)	108	4
Fear of rejection	19.6% (6)	30.8% (33)	4.7% (5)	44.9% (48)	107	5

According to Table 6.50 the main reasons given by the respondents were high interest rates (80.4%), lack of collateral (73.8%), burdensome application procedures, (47.6%), discouragement by the bank requirements (46.2%), and fear of rejection (19.6%). This implies that there is an element of self-credit rationing among the SMEs as evidenced by fear of rejection and discouragement by unattainable bank requirements. These findings concur with those of Akuetteh (2009) and Gianetti (2012). It can therefore be inferred that the study suggests that some of the SMEs perceive themselves as ineligible to obtain bank credit because of the inability to meet most of the bank lending conditions.

#### 6.13.4.6 *Asset structure*

The respondents were asked to indicate the capital structure of their businesses in the last calendar year. The results of the analysis are presented in Table 6.51.

**Table 6.51:** The estimated capital structure of the enterprise

Aspect	Value						Sample size
	Less than R50 000	R50000- R100000	R101000- R300000	R301000- R500000	R501000- R1000000	R1000000	
Fixed assets (buildings and machinery)	31.3% (72)	12.2% (28)	9.1% (21)	17.8% (41)	13.0% (30)	16.5% (38)	230
Total current assets (cash and debtors)	21.1% (51)	27.3% (66)	23.1% (56)	13.2% (32)	6.2% (15)	9.1% (22)	242
Total short-term loans (up to 12 months)	42.9% (36)	39.3% (33)	10.7% (9)	1.2% (1)	2.4% (2)	3.6% (3)	84
Long-term debt (more than 5 years e.g.	11.1% (10)	3.3% (3)	12.2% (11)	13.3% (12)	28.9% (26)	31.1% (28)	90
Debt (total bank loans)	14.3% (14)	7.1% (7)	5.1% (5)	16.3% (16)	21.4% (21)	35.7% (35)	98
Equity (personal savings, friends and family)	52.0% (103)	26.8% (53)	14.1% (28)	3.5% (7)	1.5% (3)	2.0% (4)	198
Retained income	16.1% (40)	16.1% (40)	19.4% (48)	18.1% (45)	10.9% (27)	19.4% (48)	248
Total market value of the assets (fixed, investments and cash)	8.0% (20)	15.4% (38)	13.8% (34)	13.8% (34)	18.6% (46)	30.4% (75)	247

The largest proportion of respondents, 31.3% have fixed assets of less than R50 000. On the other hand 29.5% indicated that they had more than R500 000 in fixed assets. In terms of total current assets, 27.3% indicated that their asset value is between R50 000 and R100 000 whilst 23.1% indicated that their asset values ranged between R101 000 and R300 000. The majority of the respondents (71.5%) indicated to have total current assets of not more than R300 000. Therefore, it can be concluded that small firms use internal sources of finance which do not require fixed assets as collateral in the short-term. This implies that the majority of the SMEs in the study do not have sufficient collateral to pledge to the bank as security for the loan. Therefore, these findings support the assertion by Newman (2013) that collateral is the most important constraint for SMEs to access bank credit.

In terms of total short term loans, 42.9% have loans below R50 000 whilst 39.3% have loans between R50 000 – R100 000. Only 7.1% have short-term loans to the value of more than R300 000. Close to 30% have long- term debt of between R501 000 and R1 000 000. The majority of respondents that is 58.1% indicated that they had a debt (total bank loans) of more than R500 000. In terms of value of equity 52.0% indicated the value was below R50 000 whilst 26.8% indicated that it was between R50 000 and R100 000. This serves to confirm that the majority of SMEs rely heavily on equity in the form of personal savings and loans from family and friends.

In general, it seems that the value of assets held by respondents, are too low to use as collateral for a loan. This might be the reason why the assets are not being accepted by banks as collateral since their value might be low as compared to the value of the loan. It can, however, be suggested that the firm's asset structure influences its use of debt finance. Without tangible assets the firm cannot access bank finance and has to investigate alternative sources such as suppliers' credit. These findings are consistent with Abor and Biepkke (2007) in Ghana. Empirical evidence discussed so far provides strong support for the positive relationship between asset structure and leverage predicted by capital structure theorists. The next section focuses on the products and financial services offered to SMEs by banks.

#### 6.13.4.7 *Bank products and financial services*

The respondents were further asked to indicate the extent to which SMEs use banking products and financial services. The scale items "to a large extent" and "to a very large extent" were combined together to give the rankings in Table 6.52.



**Table 6.52:** Use of banking products and services

Products and financial services	Level of Extent				Sample Size	Rank
	large and	some extent	a little extent	an extent		
Business cheque account	72.2% (179)	6.0% (15)	5.6% (14)	16.1% (40)	248	1
Supplier payments (trade credit)	51.9% (123)	22.4% (53)	7.6% (18)	18.1% (43)	237	2
Loan account	28.5% (64)	6.2% (14)	3.6% (8)	61.8% (139)	225	3
Insurance products (e.g. policies)	10.4% (24)	31.7% (73)	38.7% (89)	19.1% (44)	230	4
Collection of receivables	7.9% (18)	12.6% (29)	26.5% (61)	53.0% (122)	230	5
Leasing (hire purchase)	6.3% (14)	28.1% (63)	7.6% (17)	58.0% (130)	224	6
Foreign exchange (buying and selling foreign currency)	5.0% (11)	9.5% (21)	14.5% (32)	71.0% (157)	221	7
Consultation/advice in financial planning	4.7% (10)	19.9% (46)	55.8% (129)	19.5% (45)	231	8
Factoring – purchase of overdue accounts	1.0% (2)	3.2% (7)	6/3% (14)	89.6% (199)	222	9

The empirical evidence suggests that most respondents use the cheque account (72.2%) which offers an added benefit of the overdraft facility. This type of product usually does not require collateral for security purposes. Supplier's credit (51.9%) is the second most used form of credit as it allows those who cannot access bank loans to at least get access to some form of working capital without providing collateral. Other products and financial services offered to SMEs by banks include insurance products, collection of receivables, leasing, foreign exchange, factoring and financial planning consultation. Thus, on the part of the banks, there has been an increasing effort to introduce innovative products (Calice et al, 2012) and also cross-sell products and services (de la Torre et al (2010) so as to diversify their sources of income.

Respondents were also asked to indicate the extent to which they transact using the e-banking technology such as electronic funds payments (EFT), general internet

banking and cell phone banking. The scale items “to a large extent” and “to a very large extent” were combined together to give the rankings shown in Table 6.53.

**Table 6.53:** The level of extent SMEs use e-banking transactional methods

e-banking transactional methods	Level of Extent				Sample Size	Rank
	very large and large	To some extent	To a little extent	No to an extent at all		
Electronic Funds transfer (EFT)	46.2% (145)	12.4% (32)	5.8% (15)	25.6% (66)	258	1
Internet banking (accessing bank products via the internet)	57.1% (145)	15.4% (39)	6.3% (16)	21.3% (54)	254	2
Cell phone banking	16.9% (43)	37.8% (96)	14.6% (37)	30.7% (78)	254	3
Transfer of funds without a bank account (e.g. M-Pesa)	6.0% (15)	25.4% (64)	23.0% (58)	45.6% (115)	252	4

According to the response reflected in Table 6.53, 46.2 % of the respondents made use of electronic funds transfer (EFT) while 57.1% used general internet banking (accessing bank products via the internet). Similar results have been established in Colombia (Stephanou and Rodriguez, 2008) and de la Torre et al., (2010). This implies that a sizeable number of SMEs are adapting to new technologies, whereby business transactions are now done online. This may help to explain why distance to the bank is no longer an important factor that constraints SMEs from borrowing from the bank (see Table 6.55). This has consequently resulted in SMEs being able to transact from any geographic location.

The study also aimed to determine whether SME operators were satisfied with the overall bank loan application process, including the existing range of financial products and services offered by the banks. It emerged that about 45.1% of the SMEs seem to be very satisfied with the loan application process as shown in Table 6.54.

**Table 6.54:** Level of satisfaction of the bank loan application process

Factor	Level of satisfaction				Sample Size	Rank
	Extremely satisfied	Moderately satisfied	Slightly satisfied	Not satisfied at all		
The overall loan application process	50.0% (82)	28.7% (47)	10.4% (17)	11.0% (18)	164	1
The loan amount granted by the bank relative to the amount requested	43.2% (80)	14.8% (24)	4.9% (8)	27.0% (60)	162	2
The time taken to process the application	42.5% (70)	33.3% (55)	10.9% (18)	13.3% (22)	165	3
The simplicity of the application form	42.4% (70)	37.6% (62)	8.5% (14)	11.5% (19)	165	4
The collateral requirements	13.3% (21)	20.3% (32)	26.6% (42)	39.9% (63)	158	5
The interest rates (the cost of the loan)	7.4% (12)	25.3% (41)	29.6% (48)	37.7% (61)	162	6
The bank charges	4.2% (7)	9.1% (15)	25.0% (41)	61.7% (101)	164	7
The government guarantees	3.7% (5)	48.5% (66)	16.2% (22)	31.6% (43)	136	8

As shown in Table 6.54, 50% of the respondents indicated that they are generally satisfied with the loan application process. The majority of the SME owner/managers (37.7%) are not satisfied with the interest rates charged by the banks, while 61.7% are concerned with the high bank charges. About 40% of the respondents are not satisfied at all with the collateral requirements of the banks. Only 3.7% of the entrepreneurs are happy with government guarantee schemes. Thus, it can be concluded that SME owner/managers are generally not happy with the interest rate, bank charges and collateral requirements of the banks and therefore they may be forced to use alternative sources of funding to develop and grow their businesses.

#### 6.13.4.8 *Financing constraints*

The SMEs owners/managers were further asked to indicate the financing constraints that stop them from borrowing money from the bank. The empirical results are presented in ascending order of magnitude, with the most perceived constraint at the top of the table and the least at the bottom. The scale items “to a very large

extent” and “to a large extent” were combined to form the rankings used in Table 6.55 below.

**Table 6.55:** Factors limiting SMEs from borrowing from the banks

Factor	Level of extent					Sample	Rank
High bank charges	54.6% (136)	28.1% (70)	12.0% (30)	2.8% (7)	2.4% (6)	249	1
Lack of collateral	36.7% (91)	28.2% (70)	23.0% (57)	6.9% (17)	5.2% (13)	248	2
Fear of getting into debt	36.1% (88)	37.3% (91)	19.3% (47)	5.3% (13)	2.0% (5)	244	3
High interest rates	31.5% (79)	25.9% (65)	36.3% (91)	4.8% (12)	1.6% (4)	251	4
Lack of trust of banks	14.8% (36)	20.6% (50)	40.7% (99)	16.5% (40)	7.4% (18)	243	5
Inability to repay the loan	5.3% (13)	28.0% (69)	31.7% (78)	15.4% (38)	19.5% (48)	246	6
Banks do not understand the needs of SMEs	6.8% (17)	12.0% (30)	65.9% (164)	10.8% (27)	4.4% (11)	249	7
Poor credit record	3.7% (9)	13.9% (34)	29.5% (72)	13.1% (32)	39.8% (97)	244	8
Distance to the bank	2.1% (5)	2.9% (7)	5.4% (13)	25.7% (62)	63.9% (154)	241	9

The empirical findings indicate that high bank charges are perceived as a major financing constraint by 83% of the respondents, followed by fear of getting into debt by 73%, lack of collateral by 65%, high interest rates by 57%, lack of trust of banks by 35.4% and inability to pay the loan by 33% of the respondents respectively. The other problems identified include lack of viable business plans, banks failing to understand the needs of small businesses, and the poor credit records of the SMEs.

High interest rates could be attributed to the lack of bank-SME relationship. According to the lending relationship model by Boot and Thakor (1994), bank-firm relationships determine the collateral decision and the interest rate to be charged. Consequently, borrowers without a good credit history are charged high interest rates and high collateral provisions. Contrary to the findings of Akuetteh (2009) in

Ghana, distance to the bank is not a pressing constraint anymore due to the technological developments in online banking. High bank charges can be regarded as a result of information asymmetry on the part of SMEs.

It can therefore be concluded that the high-ranking factors that limit SMEs from borrowing from the bank include high bank charges, lack of collateral, fear of getting into debt, high interest rate, lack of trust of banks and inability to repay the loans. The following section presents the results of the validity and reliability tests for the SME survey.

## 6.14 VALIDITY AND RELIABILITY TESTS FOR THE SME SURVEY

The SME questionnaire used for this study was subjected to validity and reliability tests using confirmatory factor analysis (CFA) and Cronbach's alpha to determine its appropriateness. To test the convergent validity of the constructs, the exploratory factor analysis (EFA) was employed, firstly to determine whether the individual questions contributed to their respective constructs as contained in the questionnaire, and secondly, to identify the hidden constructs which may not be apparent from direct analysis. Bartlett's test of sphericity and the Kaiser Meyer-Olkin (KMO) measures were used to test the suitability of each question for factor analysis. The results of these tests are discussed in the following sub-section.

### 6.14.1 Validity tests: Confirmatory factor analysis

Table 6.56 depicts the results of the Bartlett's test of sphericity and the KMO value. The KMO showed a value equal to 0.902. The p-value of the Bartlett's test ( $p = 0.000$ ) is smaller than 0.05, is significant at the 99% confidence level. This result is an indication that the correlation structure of the construct is adequate to conduct a factor analysis on the items.

**Table 6.56:** KMO and Bartlett's Test

Kaiser-Meyer-Olkin Measure of Sampling Adequacy.		0.902
Bartlett's Test of Sphericity	Approx. Chi-Square	7292.55
	df	6
	Sig.	0.000

Using the Varimax rotation method (Kaiser, 1958), the factor analysis identified six components from the data. This means that there were six underlying dimensions which were identified as separate factors that relate to access to credit by SMEs as shown in Table 6.57.

**Table 6.57: Factor loadings**

Rotated Component Matrix							
Item		Component					
		1	2	3	4	5	6
20f	Poor credit record of applicant(s)	0.945					
20g	Inability to repay the loan	0.956					
20h	No relationship with the bank	0.951					
20j	Non-compliance with the National Credit Act (NCA)	0.947					
20k		0.952					
22b	Collateral requirements for bank loans are too strict			-0.768			
22e	We were afraid that our loan application would be rejected			-0.831			
22f	We were discouraged because we could not meet the bank requirements			-0.796			
27a	The loan amount granted by the bank relative to the amount we requested		0.737				
27b	The time taken to process the application		0.772				
27e	The personal guarantees required by the bank		0.839				
27f	The government guarantees		0.856				
27g	The collateral requirements		0.793				
27i	The simplicity of the application form		0.824				
18a	Bond over moveable assets				0.816		
18b	Accounts receivable				0.769		
18e	Inventories (stock)				0.715		
18f					0.833		
24a	Business cheque account					0.599	
24c	Loan account					0.623	
24d	Factoring					0.741	
24e	Leasing					0.566	
24g	Supplier payments					0.754	
26a	Electronic Funds transfer						0.891
26b	Cell phone banking						0.694
26c	Online banking						0.860
	Extraction method: PCA Rotation method: Varimax with Kaiser normalisation						
	a. Rotation converged in 6 iterations.						

(Source: SPSS 23)

As shown in Table 6. 57 factor loadings ranged from -0.831 to 0.956 surpassing the minimum threshold required of 0.4. The rotated component factor matrix converged after six iterations.

Factors extracted represented all variables in the research model. Credit worthiness (CW), credit rationing (CR), satisfaction (S), collateral (C), credit demand (CD) and e-banking (EB) loaded as expected on unique factors with significant loadings (loadings greater than 0.5, (Hair et al., 2006)). There was no problem with the nature of item loadings on each factor. As shown in Table 6.57, all items were loaded significantly onto the expected factors, with values higher than 0.4. This supports the discriminant validity of the measurement. It was therefore concluded that the 19-item scale measuring factors in access to credit were uni-dimensional, that is, all the scale indicators that were used in access to credit related questions maintained a single convergence in the analysis suggesting that there is a general agreement among the respondents on issues that relate access to credit by SMEs. The communalities of the identified components are described in the following section.

The results found in Table 6.58, indicate that the communality values for all the listed items exceeded the cut-off level of 0.4. The communalities considered acceptable given that their extraction ranges from 0.636 to 0.949 (see Table 6.58). This implies that there is a strong correlation amongst all the questions.

**Table 6.58: Communalities**

Communalities					
	Initial	Extraction		Initial	Extraction
Q24a.	1.000	.644	Q18.	.759	1.000
Q24c.	1.000	.717	Q18.	.827	1.000
Q24d.	1.000	.670	Q20f.	.932	1.000
Q24e.	1.000	.636	Q20g.	.941	1.000
Q24g.	1.000	.653	Q20h.	.944	1.000
Q27a.	1.000	.878	Q20j.	.925	1.000
Q27b.	1.000	.853	Q20k.	.949	1.000
Q27e.	1.000	.790	Q22b.	.852	1.000
Q27f.	1.000	.795	Q22e.	.837	1.000
Q27g.	1.000	.779	Q22f.	.859	1.000
Q27i.	1.000	.882	Q26a.	.842	1.000
Q18.	1.000	.784	Q26b.	.587	1.000
Q18.	1.000	.770	Q26c.	.848	1.000
Extraction Method: Principal Component Analysis.					

**Note:** items refer to components, factors and questions.

The next section deals with the extraction method based on the principal component analysis as applied to this study.

Since the study has employed the principal component analysis as the method of extraction, the total percentage of variance and cumulative percentage columns are similar to those of the first six components in the initial eigenvalues. The variance and the cumulative variance explained by the factors are shown in Table 6.59.

**Table 6.59:** Total variance explained

Component	Initial Eigenvalues		
	Total	% of Variance	Cumulative %
1	9.460	36.385	19.499
2	5.637	21.680	38.641
3	1.950	7.502	51.223
4	1.585	6.097	62.237
5	1.307	5.027	72.832
6	1.015	3.904	80.595

Table 6.59 shows that six components with eigenvalues greater than one account for 80.60% of the cumulative variance which is above the recommended threshold of 60 percent (Hair et al., 2014) to represent a good fit to the data. According to the rules of principal component analysis only factors that have eigenvalues greater than one should be retained (Ledesma and Valero-Mora, 2007). A further analysis was carried out using the scree plot. The scree plot supports the extraction method of principal component analysis from a diagrammatic point of view as shown in Figure 6.11.

The scree plot test is a graphical method of determining the number of appropriate factors to retain. In Figure 6.11 below, a cut-off of an eigenvalue  $> 1$  would give six factors. From the 6<sup>th</sup> factor on, the line is almost flat, meaning that each successive factor is accounting for smaller and smaller amounts of the total variance (Su and Yang, 2010). Thus, the scree plot test results also indicated that six factors should be retained, supporting the previous result based on the eigenvalue criterion method.



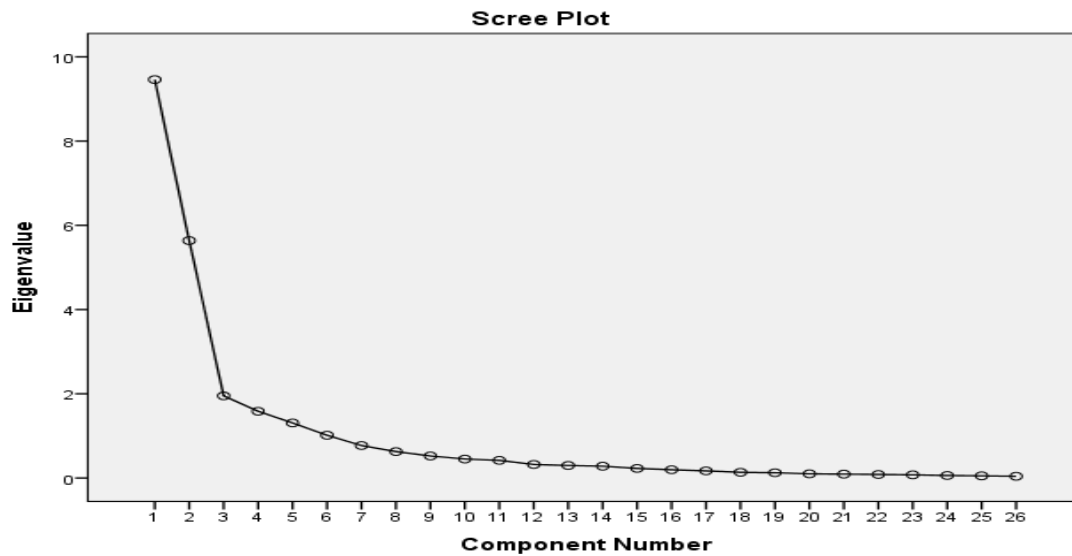

**Figure 6.11:** The Scree Plot test

Source: (SPSS 23)

Having concluded the evaluation of communalities among the determinants of access to finance by SMEs, the reliability of the constructs was tested.

### 6.15 RELIABILITY TESTS FOR THE SME SURVEY

In order to estimate the internal consistency and the reliability of factors, the questionnaire was subjected to the reliability test using Cronbach's alpha, where coefficients were computed for each of the six factors identified. The Cronbach's alpha value is a significant measure of the reliability and internal consistency among the constructs (Field, 2009). The Cronbach's alpha coefficients for the SME questionnaire are reported in Table 6.60.

The alpha coefficients of the constructs vary between 0.643 and 0.871, which suggests high reliability. The factors from the principal components analysis are grouped into six categories: creditworthiness, credit rationing, collateral, access to finance, e-banking and access to finance.

According to De Souza and Dick (2009) all coefficient alpha values of 0.6 are considered acceptable in statistical analysis. We can thus suggest that all the questionnaire items that are used in this study passed the reliability test.

**Table 6.60:** Cronbach's alpha for the constructs

Item	N	Mean	SD	Corrected item-Total Correlation	Cronbach's Alpha if item Deleted	Total Cronbach's Alphas
Information asymmetry						<b>0.842</b>
20f		13.85	11.561	.732	.788	
20g		13.59	13.413	.620	.818	
20h		13.87	13.316	.764	.779	
20j		14.67	15.724	.829	.827	
20k		12.80	14.494		.829	
Credit rationing						<b>0.737</b>
22b		5.37	6.159	.502	.720	
22e		7.18	5.477	.547	.668	
22f		6.36	4.233	.657	.532	
Collateral						<b>0.643</b>
18a		3.84	2.720	.442	.572	
18b		3.51	3.494	.378	.640	
18e		3.63	2.896	.555	.407	
Access to finance						<b>0.748</b>
24a		7.32	14.623	.513	.711	
24c		9.23	14.953	.588	.673	
24d		10.04	21.577	.396	.754	
24e		9.45	16.693	.650	.663	
24g		8.04	14.956	.535	.697	
E-Banking						<b>0.871</b>
26a		5.85	6.017	.823	.757	
26b		6.75	9.184	.635	.921	
26c		5.83	6.517	.844	.729	
Creditworthiness						<b>0.885</b>
27a		15.40	24.607	0.660	0.880	
27b		15.13	27.720	0.686	0.866	
27e		16.07	29.035	0.657	0.870	
27f		16.00	29.460	0.677	0.796	
27g		16.01	29.024	0.696	0.869	
27i		15.81	29.361	0.653	0.866	

In the following sections, correlation and regression analyses were performed to determine the associations between the dependent variable (access to credit) and independent variables (creditworthiness (CW), collateral (C), credit rationing (CR), information asymmetry (IA) and e-banking (EB)). To assess the type of relationship, a regression analysis was done to determine whether the correlation is significant.

## 6.16 CORRELATION ANALYSIS

The Pearson product-moment correlation of continuous variables was used. Table 6.61 indicates that all the factors had p-values less than 0.05 ( $p < 0.05$ ) and a coefficient higher than 0.30, meaning that they were all correlated and that the relationship was significant. Details of the correlations are presented in Table 6.61 where the green colour indicates positive and significant correlations while the green colour shows the negative but significant correlations.

**Table 6.61:** Pearson Correlation

		Correlations					
		CW	C	IA	CR	AF	EB
CW	Pearson Correlation	1	.556**	.104	-.558**	.573**	.472**
	Sig. (2-tailed)		.000	.092	.000	.000	.000
	N	262	262	262	262	262	262
C	Pearson Correlation	.556**	1	-.219**	-.429**	.507**	.333**
	Sig. (2-tailed)	.000		.000	.000	.000	.000
	N	262	262	262	262	262	262
IA	Pearson Correlation	.104	-.219**	1	-.349**	-.158*	-.118
	Sig. (2-tailed)	.092	.000		.000	.010	.055
	N	262	262	262	262	262	262
CR	Pearson Correlation	-.558**	-.429**	-.349**	1	-.412**	-.249**
	Sig. (2-tailed)	.000	.000	.000		.000	.000
	N	262	262	262	262	262	262
AF	Pearson Correlation	.573**	.507**	-.158*	-.412**	1	.530**
	Sig. (2-tailed)	.000	.000	.010	.000		.000
	N	262	262	262	262	262	262
EB	Pearson Correlation	.472**	.333**	-.118	-.249**	.530**	1
	Sig. (2-tailed)	.000	.000	.055	.000	.000	
	N	262	262	262	262	262	262
		**. Correlation is significant at the 0.01 level (2-tailed).					
		*. Correlation is significant at the 0.05 level (2-tailed).					

(Source: SPSS 23)

This leads to the following hypotheses which addresses some of the research questions posed in chapter 1 for further analysis.

- H1 There is a significant correlation (association) between creditworthiness and access to credit by SMEs
- H2 There is a significant correlation (association) between collateral and access to credit by SMEs
- H3 There is a significant correlation (association) between information asymmetry and access to credit by SMEs
- H4 There is a significant correlation (association) between credit rationing and access to credit by SMEs
- H5 There is a significant correlation (association) between e-banking (technology) and access to credit by SMEs

All the decision variables were significant and were therefore included for regression and structural equation modelling (SEM). The next section focuses on regression analysis.

## **6.17 REGRESSION ANALYSIS**

After the descriptive statistics and various diagnostic analyses it was considered important to investigate the strength of the relationships that exists among the market participants in the area of study. Hence various regression techniques were used to analyse these possible relationships and the strength of the convergence.

### **6.17.1 Model Summary (Access to finance)**

The output from the multiple regression analysis is shown in Tables 6.62 to 6.64. The overall multiple regression model is significant at a 95% level of significance ( $p < 0.05$ ). The regression model summary indicates that adjusted  $R^2$  value = .468. The  $p$ -value is less than 0.05 hence is significant as shown in Table 6.63. These results are acceptable, considering some of the previous results that are reported in similar studies on SME financing (Fatoki, 2012), or the  $R^2$  value in social sciences in general (Pallant, 2005).

The Durbin Watson score of 1.445 demonstrates that there is no auto correlation problems associated with the data used in this study. Two, is the “ideal” Durbin Watson measure of independence (Hair et al., 2006) (see Table 6.62). This indicates a high level of isolation among the independent variables of the model.

**Table 6.62: Model summary**

Model	R	R Square	Adjusted R Square	Std. Error of the Estimate	Change Statistics					Durbin-Watson
					R Square Change	F Change	df1	df2	Sig. F Change	
1	.692	.478	.468	.71958	.478	46.954	5	256	0.000	1.445
a. Predictors: (Constant), IA, C, CR, CW, EB										
b. Dependent Variable: AF										

(Source: SPSS 23)

**6.17.2 Analysis of Variance (ANOVA)**

The significance of adjusted R squared can be tested through the F-ratio and its associated probability. Meanwhile the F-value = 46.954, which is a ratio of the mean square for regression to the residual mean square (Pallant, 2010). The residual mean square indicates the difference between the actual value of the dependent variable, and the result of the regression equation (Tabachnik and Fidell, 2007). The residual difference is significant, with a p-value equal to 0.000 which is significant as shown in Table 6.63. The regression and residual are calculated from all independent variables or predictors. The F-ratio has two degrees of freedom, one related to the number of independent variables used in the model, and the other based on sample size.

**Table 6.63: Analysis of variance (ANOVA)**

ANOVA						
Model		Sum of Squares	df	Mean Square	F	Sig.
1	Regression	121.562	5	24.312	46.954	.000 <sup>b</sup>
	Residual	132.555	256	.518		
	Total	254.116	261			
a. Dependent Variable: AF						
b. Predictors: (Constant), IA, C, CR, CW, EB						

(Source : SPSS 23)

The F-ratio is significant for further analysis using the standardised coefficient regression.

### 6.17.3 Standardised coefficient

The result of the variance inflation factor (VIF) analysis (Table 6.64) demonstrates that the VIF values for all the variables do not exceed the threshold generally accepted in the literature with values of 3.3 (e.g. Petter, Straub and Rai, 2007), which indicate that no multicollinearity problems exist with the variables.

Betas represent the importance of each variable in explaining the independent variable (Tabachnik and Fidell, 2007). Also the values represent the change in the dependent variable associated with the change in the independent variable. The output from the multiple regression analysis is shown in Tables 6.62 to 6.64. The overall multiple regression model is significant at a 95% level of confidence with a p-value smaller than 0.05. There are four variables that make a statistically significant contribution (less than 0.05) (see Table 6.64). In order of importance they are creditworthiness (beta is 0.268), collateral ( $\beta = 0.178$ ), information asymmetry ( $\beta = -0.162$ ), credit rationing ( $\beta = -0.171$ ) and e-banking ( $\beta = 0.268$ ).

**Table 6.64:** Standardised coefficient

Coefficients									
Model	Unstandardized Coefficients		Standardized Coefficients	t	Sig.	95.0% Confidence Interval for B		Collinearity Statistics	
	B	Std. Error	Beta			Lower Bound	Upper Bound	Tolerance	VIF
(Constant)	1.415	.152		9.299	.000	1.115	1.714		
Ccreditworthiness	.189	.046	.268	4.144	.000	.099	.279	.488	2.051
Collateral	.182	.062	.178	2.919	.004	.059	.305	.547	1.829
Information asymmetry	-.105	.035	-.162	-2.965	.003	-.174	-.035	.686	1.457
Credit rationing	-.100	.036	-.171	-2.781	.006	-.171	-.029	.537	1.864
E-Banking	1.415	.038	.268	5.131	.000	.122	.273	.747	1.340

a. Dependent Variable: Access to finance

(Source: SPSS 23)

The derived causal relationships are indicated in Table 6.65 below.

**Table 6.65:** Factors that influence access to bank credit by SMEs

	Predictor	
H1	Creditworthiness has a positive and significant influence on access to credit by SMEs (p-value = 0.000, $\beta$ = 0.189)	Supported
H2	Collateral has a positive and significant influence on access to credit by SMEs (p-value 0.004, $\beta$ = 0.182)	Supported
H3	Information asymmetry has a negative and significant influence on access to credit by SMEs (p-value 0.003, $\beta$ = -0.105)	Supported
H4	Credit rationing has a negative and significant influence on access to credit by SMEs (p-value 0.006, $\beta$ = -0.100)	Supported
H5	Technology has a positive and insignificant influence on access to credit by SMEs (p-value 0.000, $\beta$ = 0.197)	Supported

The correlation and regressions above have highlighted the presence of associations between credit supply and its predictor variables. These relationships have portrayed interrelationships among variables. These relationships are subjected to more robust analyses in order to eliminate any noises inherent in regression analysis and report a more robust results using structural equation modelling.

## 6.18 STRUCTURAL EQUATION MODELLING

Structural Equation Modelling (SEM) was used to determine the main factors influencing access to finance by SMEs in South Africa. SEM was used to estimate all coefficients in the model in order to evaluate the significance and strength of the relationships within the model (Su and Yang, 2010).

Both latent and observable variables are represented by the rectangular shape on the model as shown in Figure 6.12. The constructs formed the latent variables while their indicators or metrics stood for the observable ones. Latent (silent) variables in SEM eliminate measurement errors leading to more valid coefficients being achieved (Pallant, 2005) as shown in Figure 6.12. As such an error term is appended to each observable variable. As shown in Figure 6.12, latent variables are connected to each other by two headed arrows that represent the covariance between the constructs. On the other hand, the observable variable of each construct connects to it by one-headed arrow that represents the causal path from the construct to the indicator as shown in Figure 6.12. Details of the proposed model are discussed in the subsequent section.

### 6.18.1 Proposed model

One of the objectives of the study sought to determine the factors that influence access to bank credit by SMEs in South Africa. Therefore a hypothetical structural equation model (Figure 6.12) was derived and the covariance among the explanatory variables thereof estimated. The dependent and explanatory variables are defined in Table 6.66 below.

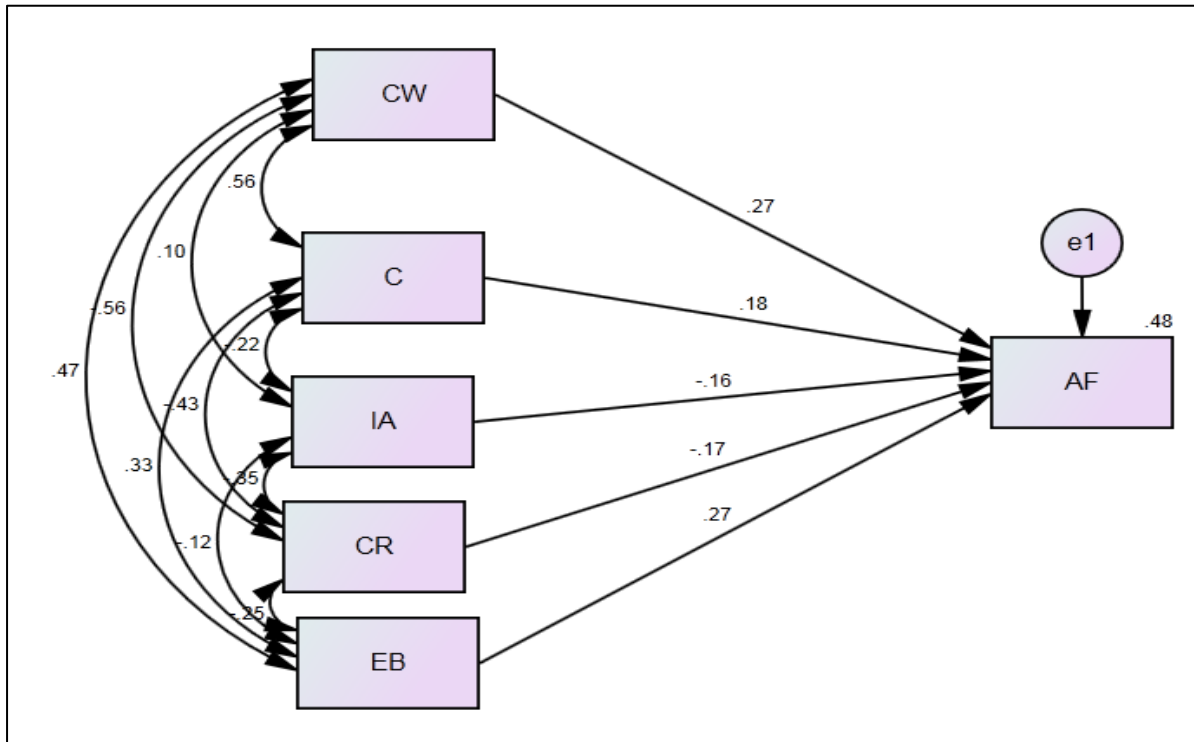

**Figure 6.12:** Proposed model for the determinants of access to finance by SMEs

**Table 6.66:** Definition of variables

Variable	Definition
CW	Creditworthiness of the firm
C	Collateral offered to the lender
IA	Information asymmetry
CR	Credit rationing
EB	E-banking
AF	Access to finance
E <sup>1</sup>	Denotes the error term



This model hypothesizes that access to finance is predicted by creditworthiness, collateral, information asymmetry, credit rationing and e-banking.

### 6.18.2 Maximum Likelihood estimates

The parameters are estimated by maximum likelihood (ML) methods rather than by ordinary least square (OLS) methods (Dion, 2008:366). OLS methods minimise the squared deviations between the values of the criterion variable and those predicted by the model (Pallant, 2010). ML (an iterative procedure) attempts to maximise the likelihood that obtained values of the criterion variables are correctly predicted (Dion, 2008).

**Table 6.67:** Regression Weights: (Group number 1 – Default model)

			Estimate	S.E.	C.R.	P
Access to credit	<---	Creditworthiness	.189	.045	4.184	***
Access to credit	<---	Collateral	.182	.062	2.947	.003
Access to credit	<---	Information asymmetry	-.105	.035	-2.993	.003
Access to credit	<---	Credit rationing	-.100	.036	-2.808	.005
Access to credit	<---	E-banking	.197	.038	5.181	***

Estimate = estimated path coefficient (prediction) for arrows in the model

SE = standard error

CR = critical ratio

P = probability value (<0.05 = significant at the 1% level \*\*\* [Garson, 2009]

The path coefficients in Table 6.67 closely match those which are obtained from multiple regressions and are significant ( $p < 0.05$ ), ranging from 0.000 to 0.005. Regression weights for the model variables were computed and presented in Table 6.68. Creditworthiness, collateral, and e-banking were found to have a positive and significant relationship with the access to bank credit ( $p < 0.05$ ) while information asymmetry and credit rationing have a negative but significant relationship with SME access to bank credit. It is observed that e-banking has a higher contribution to access to finance (0.197 or approximately 20%). Similarly a unit increase in collateral leads to an 18% increase in access to finance by SMEs holding other factors constant. These results confirm the theory of credit rationing.

**Table 6.68:** Covariances: (Group number 1 - Default model)

			Estimate	S.E.	C.R.	P	Label
Credit Rationing	<-->	E-Banking	-.560	.144	-3.901	***	
Information asymmetry	<-->	E-Banking	-.241	.127	-1.901	.057	
Collateral	<-->	E-Banking	.429	.084	5.111	***	
Creditworthiness	<-->	E-Banking	.882	.128	6.896	***	
Information asymmetry	<-->	Credit Rationing	-.894	.168	-5.325	***	
Collateral	<-->	Credit Rationing	-.695	.109	-6.371	***	
Creditworthiness	<-->	Credit Rationing	-1.313	.167	-7.874	***	
Collateral	<-->	Information asymmetry	-.320	.093	-3.452	***	
Creditworthiness	<-->	Information asymmetry	.222	.132	1.675	.094	
Creditworthiness	<-->	Collateral	.747	.095	7.850	***	

Table 6.68 above shows the bidirectional correlations between dimensions and the simple correlations between exogenous variables (predictor variables). Most of them are significant ( $p < 0.05$ ).

### 6.18.3 Squared multiple correlations

**Table 6.69** Squared multiple correlations: (Group Number 1 – Default model)

	Estimate
Credit Demand	.478

The results of the hypothesized model 1 showed that creditworthiness ( $\beta = .27$ ), collateral ( $\beta = .18$ ), information asymmetry ( $\beta = -.16$ ), credit rationing ( $\beta = -.17$ ) and e-banking ( $\beta = .27$ ) explain about 48% ( $R^2 = .48$ ) of the access to credit output model depicted in Figure 6.12 above. Finally, the Table 6.71 above shows that about 47.8 percent of the credit demand model is explained by the predictor variables in the model presented earlier as shown in Figure 6.13. The squared multiple correlation coefficients give the proportion of the variability in the item indicators which is due to the respective latent construct; having 0.478 for credit demand.

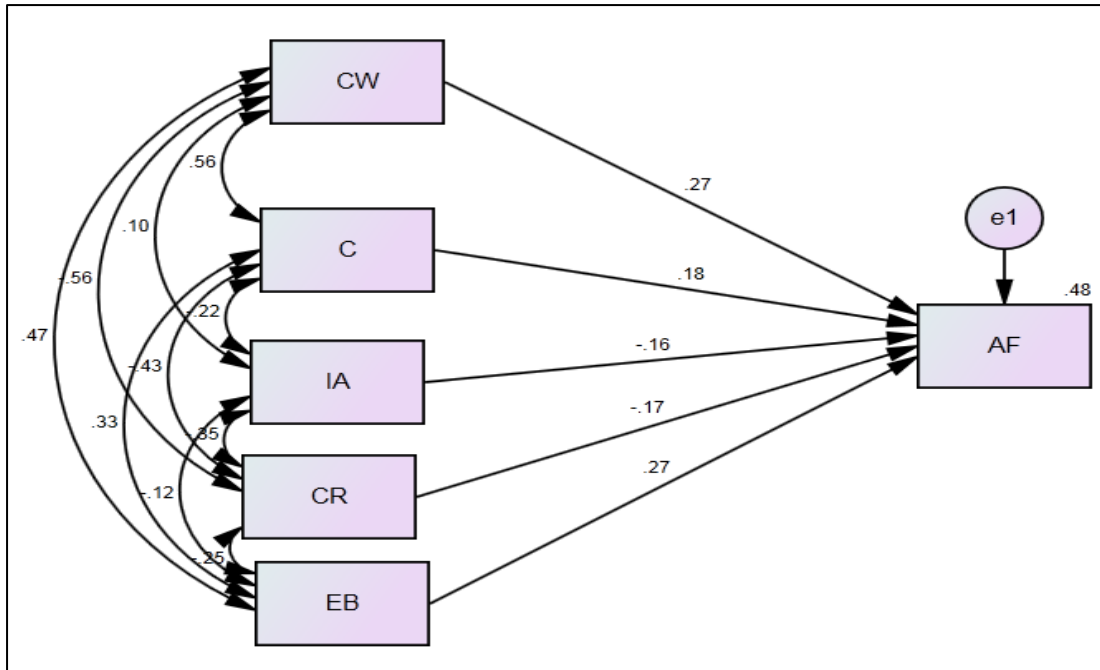

**Figure 6.13: Determinants of access to finance**

Note: For each indicator an error term was appended. The error terms were arbitrary names with a term e and a numerical value. To indicate the relationships, double headed arrows were used to represent the covariance. The single-headed arrows were used to represent the causal relationship between decision variables. Rectangle shape indicates the constructs.

Chi-Square, Root mean square error of approximation (RMSEA), Tucker Lewis Index (TLI) and Comparative Fit Index (CFI) were used to determine the goodness of fit for Model 1 above. The results are presented below.

#### **6.18.5 Results of the model evaluation regarding overall fit measurement**

The proposed model was evaluated using structural equation modelling (SEM). The data obtained was tested for reliability and validity using confirmatory factor analysis (CFA).

**Table 6.70:** Summary of the model evaluation regarding overall fit measurement

Index	Recommended value	Output	Remark
Likelihood ratio Chi square (CMIN)	< 0.05	0.000	Very good
Tucker Lewis Index (TLI)	≤ 1 (values close to 1 indicate a very good fit)	0.000	Good
Comparative Fit Index (CFI)	≤ 1 (values close to 1 indicate a very good fit)	1.000	Very good
Goodness of Fit (GFI)	Sensitive to model size	0.000	Very good
Root Mean Square Error of Approximation (RMSEA)	<0.05 to 0.08 with confidence interval	0.366	Insignificant, poor model fit
Normed Fit Index (NFI)	≤1 (values close to 1 indicate a very good fit); indices < 0.9 can be improved substantially.	1.000	Very good
PCLOSE	< 0.05	0.000	Very good

SEM was used to test if the empirical data conformed to the presumed model. The model included 21 items describing five latent constructs: creditworthiness, collateral, information asymmetry, credit rationing and e-banking. The measurement model test presented a good fit between the data and the proposed measurement model. The value of GFI is 1.000. RMSEA was less than the recommended range of acceptability (<0.05-0.08) suggested by MacCallum *et al.* (1996). Thus RAMSEA showed a poor model fit and hence the results of this index were discarded. Consistent with Hair *et al.* (2014) it was concluded that the measurement model provides a good fit with the data based on assessment criteria such as GFI, CMIN, PCLOSE, NFI, TLI and CFI and.

## 6.19 DISCUSSION OF RESULTS

Figure 7.6 above presents the significant structural relationships among the research variables and the standardised path coefficients. Since the model fit the data well, ideally we look at the paths. Properties of the causal paths (unstandardized path coefficients ( $\beta$ ), standard error of regression weight, probability values and hypotheses result) are shown in Table 6.71.

**Table 6.71:** Summary of the structural model

Construct	Path	Construct	Un- standardised Path coefficients ( $\beta$ )	Standard Error of Regression Weight	Pro- bability	Hypothesi s Result
Access to finance	<---	Creditworthiness	0.189	0.045	0.000	Reject $H_0$ at $\alpha = 0.05$
Access to finance	<---	Collateral	0.182	0.062	0.003	Reject $H_0$ at $\alpha = 0.05$
Access to finance	<---	Information asymmetry	-0.105	0.035	0.003	Reject $H_0$ at $\alpha = 0.05$
Access to finance	<---	Credit rationing	-0.100	0.036	0.005	Reject $H_0$ at $\alpha = 0.05$
Access to finance	<---	E-banking	0.197	0.038	0.000	Reject $H_0$ at $\alpha = 0.05$

Based on Figure 6.13 the results of the hypothesis testing are summarised in Tables 6.72. Most of the hypotheses were strongly supported. The results indicate a positive and significant influence of creditworthiness (p-value = 0.000,  $\beta$  = 0.189), collateral (p-value 0.004,  $\beta$  = 0.182) and e-banking (p-value 0.000,  $\beta$  = 0.197) on access to bank credit by SMEs. However, the influence of information asymmetry (p-value 0.003,  $\beta$  = -0.105) and credit rationing (p-value 0.006,  $\beta$  = -0.100) is negative but significant. These results are in support of the theory of credit rationing (Stiglitz and Weiss, 1981).

These results show that creditworthiness, collateral, information asymmetry, credit rationing, and e-banking are significant predictors of SME access to finance. This study established that possession of the appropriate collateral commensurate with loan term, creditworthiness and adoption of technology (e-banking) paves the way for SME access to bank credit. This finding corroborates Inderst and Muller (2007) who argue that collateral assures the banks of the entrepreneurs willingness to repay the loan thereby raising the probability that credit will be granted to the SME. Furthermore, collateral is believed to reduce information asymmetry between the SME and the lender.

**Table 6.72:** The result of the hypothesis testing

Hypothesis	Hypothesis statement	Result
H <sub>1</sub>	Creditworthiness has an influence on SME access to finance	Supported
H <sub>2</sub>	Collateral has an influence on SME access to finance	Supported
H <sub>3</sub>	Information asymmetry has an influence on SME access to finance	Supported
H <sub>4</sub>	Credit rationing has an influence on SME access to finance	Supported
H <sub>5</sub>	E-banking has an influence on SME access to finance	Supported

The study also established that information asymmetry has a negative and significant influence on SME access to credit. Thus, the higher the information asymmetry, the lower the probability of accessing finances. Therefore, this calls for a higher risk premium and collateral with a stable value. However, the findings of this study indicate that adoption of technology such as e-banking and cell phone banking increases the chances of accessing bank credit irrespective of geographical location or distance from the bank.

## **6.20 SUMMARY OF THE RESULTS OF THE SME SURVEY**

This chapter presented the results based on the methodology described in chapter five.

A total of 262 questionnaires were returned, which represents a 52.4%. The demographic profile of the 262 respondents indicated that 56.5% were males whilst 43.5% were females. In terms of age, 31% of the respondents were below the age of 30 years whilst 24% were aged between 30 and 39. About 30% of the respondents have a university degree. The majority of the businesses are in the finance, insurance, real estate and business services; retail and hotel services and transport and communications. The high-ranking factors that limit SMEs from borrowing from the bank include high bank charges, lack of collateral, fear of getting into debt, high interest rate, lack of trust of banks and inability to repay the loans.

The measuring instrument was tested for reliability and convergent validity before correlation; regression analysis and structural equation modelling were done. The Bartlett's test of sphericity and the Kaiser Meyer-Olkin (KMO) measures were used

to test the suitability of each identified construct. The results showed that the measurement instrument was reliable. However, one variable, bank-SME relationship was eliminated due to poor reliability results. Correlation between variables was deemed suitable for use in the regression and structural equation modelling (SEM). The correlation showed an association of all the decision variables for the access to finance model.

Multiple regression analysis and SEM showed that technology was the main contributing factor to access to finance. Access to SME credit was found to be a function of creditworthiness, collateral, technology (e-banking), information asymmetry and credit rationing. However, information asymmetry and credit rationing had a negative and significant influence on access to credit. It can therefore be concluded that the chapter has demonstrated endogenous and exogenous variables in the access to credit function.

## **6.21 CHAPTER SUMMARY**

This chapter has shown that banks are involved with SMEs to the extent of having separate units responsible for SME relations. However banks are faced with a number of challenges that deter them from funding SMEs. These challenges include macroeconomic, bank-specific and SME-specific factors. The chapter has also shown that bank credit supply to SMEs is influenced by transaction costs, collateral, lending technology, innovative strategies and creditworthiness of the SMEs. From the SME perspective, access to finance is influenced by creditworthiness, collateral, information asymmetry, credit rationing and e-banking in the form of internet and cell-phone banking. Both the SMEs and banks perceive creditworthiness, collateral and technology to be the most important factors influencing SME access to credit. From the supply side, lending technology had the greatest influence on credit supply while e-banking had the greatest influence on the demand side. The next chapter presents a summary and synthesis of the results, the contribution of this study to the body of knowledge and some recommendations for future studies.

## **CHAPTER 7**

### **SUMMARY OF FINDINGS, CONCLUSION AND RECOMMENDATIONS**

#### **7.1 Introduction**

It is a generally recognised fact that SMEs are the cornerstone of the industrial and commercial structure in developed, but more particularly in the developing countries, and are a major source of innovation and job creation. At the same time, it has been established that because of their very nature, SMEs are faced with many challenges, which are less relevant to large companies. One of the most enduring challenges they face pertains to their difficulty in obtaining external finance, especially medium- to long-term loans, which is indispensable for their development and expansion. In recognition of their contribution as catalysts of economic growth and development, as well as the challenges they encounter in raising external finance, many governments have devoted particular attention to them by way of initiating a wide range of interventions aimed at alleviating the severity of challenges confronting the SMEs.

Whilst profit maximisation is the prime objective of banks, SME financing is considered as risky due to default risk and lack of collateral. Furthermore, it seems that the drive to minimise risks, informs the decision of banks to minimise loan approvals for SMEs. This study therefore, aimed to establish the role of banks in financing this segment of the economy in order to reduce the failure rate of SMEs and ensure sustainable growth. SME financing is beset by major obstacles on both sides of the divide, namely the supply side as well as the demand side. Furthermore, the study sought to determine the reasons for the prevalence of such obstacles from the banks' and the SMEs' perspectives.

This chapter, firstly, recaps the objectives of the study. Secondly, it presents a summary of the findings of the study, and finally recommendations are made on further research as informed by the scope of this research.



## **7.2 Revisiting the research problem, research objectives and research hypotheses**

The main aim of this research was to investigate the credit rationing behaviour of banks towards SMEs in South Africa. According to FinMark Trust (2006), only two percent of new SMEs in South Africa are able to access bank loans. Previous studies have identified constrained access to external finance, especially bank credit, as a critical factor that inhibits the development and sustainable growth of SMEs. It was also observed that the largest proportion of the SME sector is unable to access loans from the commercial banks (Fatoki and Musara, 2012). The study was therefore motivated by the high failure rate of SMEs in South Africa, which is attributed to a lack of access to finance. Furthermore, with increasing unemployment, the SME sector is seen to have prospects for creating employment and improving the general standard of living in South Africa (NCR, 2012). In view of these observations, the study intended to address the following objectives:

- to investigate banks' involvement in SME financing.
- to determine the factors driving commercial banks' desire to become involved with SMEs.
- to investigate the obstacles to SME financing faced by commercial banks in South Africa.
- to determine how banks manage credit risk associated with credit supply (SME financing) to SMEs.
- to determine the factors which influence the supply of bank credit to the SME sector in South Africa.
- to investigate the challenges faced by SMEs in accessing bank finance.
- to determine the factors which influence the access to bank credit by SMEs in South Africa.

The following section presents the key findings of the study based on the research objectives, corresponding questions and the research hypotheses that were used to guide the investigation. Details of the results of the research hypotheses testing are summarised in Tables 7.1 and 7.2 relating to the questionnaires on the banks and the SMEs respectively.

**Table 7.1:** Research hypotheses (Credit supply)

<b>Hypothesis</b>	<b>Hypothesis statement</b>	<b>Result</b>
H <sub>1</sub>	Transaction costs have an influence on credit supply	Supported
H <sub>2</sub>	Collateral has an influence on credit supply	Supported
H <sub>3</sub>	Lending technology has an influence on credit supply	Supported
H <sub>4</sub>	Innovative strategies have an influence on credit supply	Supported
H <sub>5</sub>	Creditworthiness has an influence on credit supply	Supported
H <sub>6</sub>	Bank-SME relationship has an influence on credit supply	Not supported
H <sub>7</sub>	Risk Management has an influence on credit supply	Not supported
H <sub>8</sub>	Lending technology has an influence on innovative strategies	Supported

**Table 7.2:** Research hypotheses (Access to finance)

<b>Hypothesis</b>	<b>Hypothesis statement</b>	<b>Result</b>
H <sub>1</sub>	Creditworthiness has an influence on SME access to finance	Supported
H <sub>2</sub>	Collateral has an influence on SME access to finance	Supported
H <sub>3</sub>	Information asymmetry has an influence on SME access to finance	Supported
H <sub>4</sub>	Credit rationing has an influence on SME access to finance	Supported
H <sub>5</sub>	E-banking has an influence on SME access to finance	Supported

From the analysis contained in chapter six, it was found that most of the hypotheses were supported except for the bank-firm relationship and risk management variables which were dropped by the structural equation modelling test. The next section deals with the key findings of the research.

### **7.3 Key findings of the research**

In support of achieving the objectives of this study, two questionnaires were compiled, one directed to the identified respondent banks and the other to SME owners/managers. The rationale for these questionnaires was to solicit independent opinions from both the supply- and demand-sides on issues pertaining to SME access to finance and identify the variables that influence the supply of bank credit to

SMEs as well as the demand of credit by SMEs. Thus, the study analysed survey data collected during 2014 from the sampled province of Gauteng. The findings of the study are divided into two categories based on the two surveys, namely the findings from the banks' analysis and those from the SMEs. The next section focuses on the key findings from the analysis of the bank's survey.

### **7.3.1 Key findings from the bank analysis**

This section of the chapter provides the key findings based on the bank questionnaire. The discussion of this study is based on the results and interpretation as well as inferences made from the results in accordance with the research objectives. The bank questionnaire aimed to achieve the following five objectives:

- *To investigate the extent of banks' involvement with SMEs.*  
The majority of the respondents attested to having separate SME units responsible for managing SME relations, in a bid to be more responsive to the needs of their SME clients.
- *To determine the drivers of SME financing by banks in South Africa.*  
The study revealed that the perceived profitability of the SME segment is the most important driver of the banks' involvement with SMEs. It can therefore be inferred that most banks find it worthwhile to do business with SMEs that have a profitability potential on a sustainable basis. This finding is in line with that of De la Torre et al (2010) and Calice et al (2012), where it was observed that banks' interest towards dealing with SMEs appears to be motivated by the business objective of ensuring a profit.
- *To investigate the obstacles to SME financing.*  
The obstacles can be grouped into three categories, namely macroeconomic, firm-specific and bank-specific obstacles. According to the study, empirical results indicate that macroeconomic obstacles topped the list including the Financial Intelligence Centre Act (FICA) regulation which ranked highest, high interest rates and fluctuating exchange rates. Banks therefore see the regulatory environment as a major impediment or binding constraint in their involvement with SMEs. These obstacles are followed by firm-specific obstacles which include information asymmetry, lack of collateral, high SME

risk exposure and poor quality of financial statements. Information asymmetry makes it difficult for banks to ascertain whether the SMEs have the capacity to repay and/or willingness to repay the loans once issued. Consequently, this information asymmetry undermines financing from banks that require hard, objective and transparent information. Banks mainly accept fixed assets as security on medium- and long-term loans, while regulations prevent the use of receivables, inventory and equipment as collateral.

Lastly, bank-specific constraints were given the lowest importance and these included the inability to diversify risk across SME clients, and the difficulty in standardising products and procedures in the banks' bid to serve more SMEs in terms of credit provisioning. These findings are aligned with the literature review, where it was established that SMEs with demands for smaller loans face higher transaction costs and consequently higher risk premiums since they are typically more opaque and have less collateral to offer. Previous studies have also found information asymmetry to be a significant obstacle to SME financing (see section 3.6). Identification of these obstacles should be seen as a positive sign representing a forward-looking approach towards better quality and wider variety of bank services. Improvements on these fronts would certainly contribute to alleviating the problems of insufficient demand for credit; shorten the time and complexity of credit application and risk-evaluation procedures; and perhaps lower banks' requirements concerned with the level of loan collateralisation.

- *To determine how banks manage credit risk associated with SME financing.* Credit risk, defined in the literature as the risk that the borrower will not pay a loan as called for in the original loan agreement and eventually default on the obligation is one of the primary risks in SME financing. The magnitude of credit risk can be increased by changes in the macroeconomic environment such as interest rates and exchange rates. Amongst the banks surveyed, risk management is mainly centralised (done at the head office) and overseen by a credit analyst. Furthermore, most of the banks indicated that SME loans are monitored through automatically generated triggers such as default of payment in order to underpin SME efficiency.

Due to information asymmetry of small businesses, banks have to manage the risk associated with SME financing. Although there is a high demand for bank credit by SMEs, the survey response indicated that credit is not readily available to all SMEs. Based on the empirical findings it appears that banks respond to excess credit demand by increasing collateral requirements which, according to Stiglitz and Weiss (1981), is a form of credit rationing. Pledging of assets that do not lose much value overtime and are relatively easy to liquidate provides banks with greater assurance of repayment, even when contract enforcement processes are relatively imperfect. Therefore, collateral remains an important deterministic factor for SMEs to access bank credit. Thus, banks tend to impose stringent collateral requirements that are unattainable for the majority of the SMEs. Consequently SMEs are forced out of the market and rationed from the available bank credit or obliged to find another source of credit. Banks are therefore developing innovative strategies aimed at increasing SME access to credit which include correspondent banking and psychometric testing (see Table 6.18).

- *To determine the factors that influence credit supply to SMEs by banks in South Africa.*

The factors under investigation included transaction costs, collateral, lending technology, innovative strategies, creditworthiness, bank-SME-relationship and risk management. The correlation and multiple regressions found all variables to be significant except the bank-SME relationship factor. After applying the structural equation modelling, lending technology, collateral, transaction costs, creditworthiness and innovative technologies account for 48% of the credit supply to SMEs. Risk management and bank-firm relationship were insignificant in explaining credit supply to SMEs by banks.

Based on the empirical results, it can be concluded that lending technology is the most significant predictor which influences bank financing to SMEs. Therefore, software technology developers and banks should focus on producing software compatible with and can easily be integrated into the lending techniques developed for SME financing.

The Bank-SME relationship factor was found to have a positive but insignificant influence on credit supply. However, its coefficient was positive, indicating that the bank-SME relationship is an essential factor in determining credit availability to SMEs. A summary of the main findings from the analysis of the SME questionnaire is presented in Table 7.3.

**Table 7.3:** Summary of conclusions from the bank analysis

1	Banks regard the SME sector as a strategic sector; therefore have dedicated units to manage SME relations.
2	Banks predominantly offer SMEs short-term credit which does not need collateral for security.
3	Banks are offering diversified products and services, not just loans.
4	Main obstacles to SME financing include regulations such as FICA and the NCA, lack of collateral, information asymmetry and lack of a quality market. Thus, the ease of doing business in South Africa is hampered by regulation.
5	The criteria used to determine the creditworthiness of SMEs include credit quality, profitability of the firm, and size of exposure.
6	Banks respond to excess credit demand from SMEs by increasing the collateral requirements and declining credit to SMEs regarded as high risk borrowers.
7	The credit risk management function of the banks is largely centralised at the head office. The cost-reducing techniques used by banks include low-cost branches, correspondent banking, contact centre models and mobile-phone based products.
8	The most important lending technologies used by banks include financial-statement lending and asset-based lending based on hard information which SMEs cannot provide.
9	Innovative strategies used in SME financing include correspondent banking and psychometric testing.
10	Determinants of credit supply are transaction costs, collateral, technology, creditworthiness and innovative strategies.

Based on the above, it is clear that the findings support Kira and He (2012), who indicated that collateral requirement is a key determinant for SMEs to successfully access bank finance. In general, it seems that adequate collateral remains the primary factor for banks when considering credit provisioning for SMEs. In order to provide the view of credit from an SME's perspective, the next section provides a summary of the key results from the analysis of the SME survey.

### 7.3.2 Key findings from the SME analysis

As stated in chapter six, one of the objectives of the SME survey was to shed some light on the problems and dilemmas associated with SME financing as perceived by SMEs. Therefore, the results of the analysis of the SME questionnaire should be seen as complementary to the conclusions drawn from the empirical analysis of the same issues from the banks' perspective. In this section, the answers to the research questions, as set out in section 1.5 of chapter 1, are summarised, based on the findings reported and discussed in chapter six and the following objectives:

- *To investigate the challenges faced by SMEs in accessing bank finance.*

The analyses conducted and presented in chapter six addressed the objective that focused on the investigation of the challenges faced by SMEs in accessing bank finance. The empirical results indicate that high bank charges were the most significant challenge faced by SMEs when accessing bank finance. SMEs are particularly concerned about the costs associated with depositing and withdrawing money from their bank accounts. This suggests that banks tend to lose SME customers when they are forced to turn elsewhere for alternative cheaper sources of funding. Other challenges identified include lack of collateral, high interest rates, lack of trust of banks, over-indebtedness, poor credit record and lack of viable business plans. SME entrepreneurs and managers should seek to develop and improve their information management practices by keeping proper and accurate records of the firm's operations. However, it must be noted that about 66% of the respondents indicated that the banks do not understand the needs of small businesses (see section 7.3.10). Banks should therefore consider designing and customising products and services to suit the needs of SMEs.

- *To determine the factors which influence the access of bank credit by SMEs in South Africa.*

Another objective of the research focused on the investigation of the factors that influence SME access to bank finance. The output of the structural equation modelling presented in Figure 7.5 indicates that collateral, creditworthiness and technology are major determinants of SME access to bank finance in South Africa. These factors were reported to have a positive

and significant influence on SME access to bank finance. This suggests that SMEs that have adequate collateral, are credit-worthy, adopt the new e-banking technologies should have an increasing chance of acquiring credit from a bank. These results corroborate the literature study in chapter four.

The findings of the study revealed that information asymmetry and credit rationing variables have a negative and significant influence on SME access to finance. The implication seems to be that SMEs that have a high level of opaqueness have less chances of accessing bank credit. These findings are in line with those of Stiglitz and Weiss (1981) and Bellier, Sayeh & Serve (2012), who established that credit availability decreases with increasing information asymmetry.

The study has highlighted that the availability of collateral signifies a positive and significant relationship with SMEs access to credit. Collateral can therefore be a pivotal factor for SMEs to access finance from the banks. The results also indicate that SMEs' lack of tangible assets or collateral hinder their access to bank finance. Based on the findings of the study, most of the SMEs whose loan applications were rejected lacked tangible assets that can be pledged as collateral. A summary of the main findings from the analysis of the SME questionnaire is presented in Table 7.4.

**Table 7.4:** Summary of conclusions from the SME questionnaire

1	Challenges faced by SMEs include high bank charges, lack of collateral, high interest rates, and fear of getting into debt.
2	Banks do not understand the needs of SMEs. SME owners require relatively small loans which are payable over a short period of time without the collateral requirement.
3	Determinants of access to credit by SMEs include creditworthiness, collateral, information asymmetry, credit rationing and the adoption of e-technology.

Considering the findings from both the banks and SMEs, it can be concluded that collateral, technology, creditworthiness and information asymmetry are significant factors of SME financing in South Africa. This study has therefore proposed some policy recommendations in the next section for consideration by financial institutions to address SME access to external finance by minimising information asymmetry and improving credit accessibility and thus reducing credit rationing. The next section deals with the final recommendations of this study.



## **7.4 Recommendations**

Based on the literature and the findings of empirical analysis, this section elaborates on potential strategies to improve bank financing to South African SMEs.

### **7.4.1 Collateral**

According to the literature, collateral assures the bank of the entrepreneur's willingness to repay the loan and thus raises the probability that credit will be granted to the SME owner/manager. However, the study has revealed that the majority of SMEs do not have access to long-term credit such as mortgage bonds on land and buildings. SMEs need medium- to long-term credit for the acquisition of fixed assets in the form of land, buildings and capital equipment which may then be used as collateral to secure bank loans. The results also indicate that most SMEs lack the financial resources or capital equipment to use as collateral to secure bank loans.

Banks could also consider broadening the range of items they accept as collateral. According to the analysis (see Table 6.16) banks are increasingly using insurance policies (ranked 1) as security for the unsecured lending followed by property and investment. Use of insurance policies to secure SME loan applications is on the increase because the majority of the SMEs do not possess sufficient assets for collateral as per bank requirement. Therefore, banks should consider moving away from requiring solely physical collateral and propose alternative practices such as unsecured lending that may mitigate uncertainties in loan issuing transactions. The use of membership guarantees through a cooperative society, sales contracts and lien on equipment financed could also be considered. Furthermore, excessive and over complex regulations could be relaxed in order for SMEs to gain access to bank credit.

### **7.4.2 Loan products and financial services**

The study has highlighted that there is a high demand for short-term loans in the form of credit cards and overdraft. The obvious conclusion was that banks predominantly offer short-term credit to SMEs which does not need collateral for security as opposed to the asset-based finances. According to the findings of the SMEs' survey, it was established that banks do not understand the needs of SME borrowers (see section 6.3.10). The banks therefore need to recognise the needs of

the SMEs in order to come up with appropriate financing guidelines that would facilitate credit availability to SMEs. It is therefore recommended that:

- Banks should develop a wide range of fee-based, non-lending products and financial services for SMEs. Thus, in addition to lending, other lucrative fee-based services such as payments, savings and advisory services could be offered. Such a move can deepen the engagement of banks with SMEs in an effort to become the principal bank for the SMEs they engage. Consequently, this may facilitate increasing the amount of lending to each SME while attracting other clients (for example, SME employees, owner/managers and their family members). Therefore, banks should develop a wide range of complementary products and financial services that are attractive to SMEs.
- Banks can also offer customised products and financial services across SMEs and economic sectors so as to meet the firm specific or sector-specific needs. In so doing banks can broaden their sources of income and diversify risk in terms of deriving income from non-lending activities.

The study also established that SMEs usually require small loans on a short-term basis rather than large medium- to long-term loans, which require collateralisation.

#### **7.4.3 Lending technology and innovative strategies**

Based on the empirical findings of the study, it was established that lending technology is the most significant factor influencing the supply of credit to SMEs. The study established that financial statement lending is the most important technique used by banks to screen SMEs, followed by asset backed-lending and leasing. However, these traditional lending techniques are not suitable for screening SME loan applications because the majority of the SMEs do not possess the required documentation to enable this process.

The structural equation model indicated that lending technology has the greatest influence on credit supply via innovative strategies. This implies that banks should concentrate more on improving the lending techniques that they use for SMEs through the use of innovative approaches that increase SMEs access to finance

without hampering the performance and sustainability of banks. Fundamental innovation in both physical and virtual distribution channels can radically reduce the costs for banks and their SME customers alike. In terms of distribution, banks could use innovative strategies such as correspondent banking (use of retail outlets) in order to expand their distribution reach to as many SMEs as possible (see section 4.6). Other technology-led innovations that banks can embark on include implementation of the contact centre model, use of mobile-phone-based products such as M-Pesa and Point of Sale (POS) - enabled agents (see section 4.6 and Table 6.6).

In order to increase credit supply to SMEs, banks could radically lower transaction costs through the use of technology such as internet banking, so that more SMEs have access to banking products and services. Therefore, it is recommended that software technology developers and banks should focus on producing software that are compatible with and can easily be adopted by SMEs. Easy adoption and accessibility of e-banking by SMEs could be the key to accessing bank finance. If traditional lending strategies do not work for SME financing, then banks need to develop innovative techniques that will capture this supposedly potential market.

#### **7.4.4 Information asymmetry**

A number of studies have shown how SMEs have encountered difficulties in accessing bank credit as a result of the problems of information asymmetry (Akuetteh, 2009; Fatoki, 2010; Musara and Fatoki, 2012). The findings of this study have confirmed the difficulty that SMEs encounter in accessing bank financing due to problems of information asymmetry as most SMEs are unable to provide their banks with the requisite information. This is due to the fact that SMEs are unable to keep records, have unreliable financial statements and also lack collateral. In order to address the problem of information asymmetry, the following steps are recommended:

- Assist SME owner/managers to develop and improve information management practices by keeping proper and accurate records of their business operations. This can be achieved by training SME owner/managers. Such a move has the potential of reducing information asymmetry and consequently the banks' perception of risks. Ensuring proper accounting

practices, internal control systems and adequate information disclosure is likely to increase transparency.

- Encourage regular updating of information pertaining to changes in business ownership and structures. The filing of relevant documentation and mandatory returns regarding taxes and other regulations must be strictly enforced and adhered to.
- Improve the reliability of financial information provided by SMEs by encouraging them to adopt user-friendly accounting systems and reporting requirements consistent with international best practices and enforce such requirements.
- Proactively watch out for early warning signs of future loan repayment problems and initiate vigorous collection efforts to avoid default. This can be achieved by using both hard and soft information in their lending decisions; and
- Support the ability of business development service providers in order to make SMEs more creditworthy through support measures such as training on book-keeping, costing, marketing skills, financial and human resources management to ensure reliability of financial and business information.

#### **7.4.5 Bank-SME relationship**

In view of the benefits outlined in the literature study regarding durable relationship lending, the following recommendations are made to banks in order to enhance SME financing:

- Foster the development of a durable and comprehensive bank-SME relationship that extends beyond credit accessibility. This can be achieved by educating and encouraging small business owners/managers to practise regular banking and relationship building with their banks at all times other than when they are in need of funding.
- Encourage the formation of associations within sectors and communities to ensure uniformity in problem identification and structuring of solutions.
- Encourage SMEs to register and formalise their relationship with service providers such as business advisory services, legal, accounting and auditing services. This could help improve the reliability of financial information

provided and develop a culture of transparency and accountability in dealing with banks.

Contrary to claims in the literature, the analysis established that bank-SME relationship is not an important factor influencing credit supply to SMEs (positive and insignificant). Banks are therefore encouraged to foster relationship lending to SMEs who do not meet the collateral requirements for bank loans. If the bank-SME relationship is well developed, it can help reduce the information asymmetry problems through the provision of reliable information about an entrepreneur's credit quality.

#### **7.4.6 Risk Management**

The results of the study indicate that risk management has a negative and insignificant influence on the supply of credit to SMEs. Due to information asymmetry among SMEs, the traditional credit scoring models based on financial statements and collateral seems to be inappropriate for assessing SMEs in emerging markets where costs have to be kept low. It is therefore recommended that:

- Banks should develop new approaches to assess the creditworthiness of SMEs rather than the traditional credit scoring techniques. These new approaches include psychometric testing which uses test scores to separate good clients from bad ones; and the use of the Qualitative Credit Assessment – a 15-20 minute assessment tool (see section 4.6). As such, banks should manage risk innovatively by designing simple, data- and technology-enabled approaches which go beyond the standard risk management models, and accommodate the characteristics of their SME customers.
- Banks can also manage risk better through diversification of products and financial services offered to SMEs, a reduction of information asymmetry through bank-SME relationships and the use of more sophisticated risk management tools.

Given the importance of the SME sector to economic development in South Africa, particularly in terms of its contribution to innovative activity, productivity improvement and job creation, understanding the determinants of access to SME finance is a topic that deserves a closer attention by commercial banks. Banks need to recognise the

effect their lending policies might have on SMEs. Strict lending requirements and high levels of scrutiny from banks tend to intimidate SMEs, especially those without collateral. This discourages many SMEs seeking external financing, and may affect the growth of the SME sector, especially in technology-intensive industries where SMEs require substantial amounts of capital to grow rapidly in their initial stages of development. Banks should therefore consider changing their lending policies according to the characteristics of the market in which the SMEs operate and the SME's growth potential, and not simply base their lending decisions on the basis of past performance.

In view of the preceding recommendations, the contribution of this study to the body of knowledge is discussed in the ensuing section.

## **7.5 CONTRIBUTION OF THE STUDY**

The empirical results of the study provide new insights into SME financing, dispelling the myth that banks are not interested in financing SMEs. Following from the analysis, evidence emerged that banks have the potential to increase their share of the SME market in a sustainable way. Although previous studies focused on analysing the access of SMEs to finance (Fatoki, 2010; Musara and Fatoki, 2012), there seems to be a limited focus on the influence of technology and relationship lending of bank credit supply to SMEs. As such, this study focused on the influence of latent factors on SME financing from both the supply- and demand-sides. By and large, studies have not striven to establish the causal relationship between variables. They have been generally limited to establishing relationships between SME characteristics and access to finance from the demand side. In contrast, this study evaluates the contribution of individual factors to credit supply to SMEs.

In this study it is argued that bank credit supply to SMEs is a function of transaction costs, collateral, lending technology and creditworthiness; and that the relationship is significant. These findings corroborate those of Fenwick and Lyne (1998), who found that high transaction costs faced by households in the former KwaZulu homelands, limit their access to formal credit markets. Furthermore, the study empirically proved that lending technology has the greatest influence on credit supply. It has been

shown that lending technology positively and significantly influences credit supply. Therefore, banks need to invest more on lending technologies in order to increase credit supply to SMEs. On the other hand, an increase in the adoption of technology by SMEs leads to an increase in access of finance. Also, transaction costs and creditworthiness were found to have a negative and significant influence on credit supply to SMEs. Thus, it can be inferred that banks should strive to reduce transaction costs associated with SME financing in order to increase credit supply to SMEs. Therefore, banks can reduce SME information asymmetry through the fostering of relationships with SMEs and the cross-selling of non-lending products in order to reduce the risk associated with SME financing.

The study contributes to the existing body of knowledge by focusing on SME financing from both the supply- and demand-side perspective in order to get the opinions of both parties simultaneously. Therefore, the study will serve as a source of reference for subsequent research in the area of SME financing.

According to the findings of this study, the main obstacles to SME financing include compliance with the FICA and NCA regulations, lack of collateral, information asymmetry and lack of a quality market. Thus, it can be concluded that the ease of doing business in South Africa is hampered by regulation. Regulatory instruments such as the FICA and NCA Acts distort the credit attractiveness and the risk portfolios of some sectors whose performances are critical to the overall performance of the economy. It is therefore suggested that the application of such policies should be strategically guarded with sector singularity without compromising the consorted objective of such regulatory instruments.

## **7.6 LIMITATIONS OF THE STUDY**

This study focused on the access of SMEs to bank credit in South Africa. The main limitation of the study was the non-availability of borrower specific data on the amount of credit accessed from the banks by SMEs. This was mainly due to confidentiality reasons. To circumvent this challenge, the study used survey data based on the opinions of bank officials and SME owners.

Secondly, the survey was limited to banks and SMEs in the Gauteng province due to its accessibility and it being the economic hub of South Africa. However, the sampled province was considered sufficient to generalise the results for economies with similar circumstances. Thirdly, all data was gathered at a specific time, thus the variables, responses and findings may be limited to that point in time.

Lastly, no authentic database existed with respect to the number of SMEs nationally or in the sampled province. Hence, the study relied on registers of provincial organisations that have a direct relationship with SMEs. It was also recognised that there are other noticeable features such as political and socioeconomic variables which could possibly impact SMEs' access to debt financing since such variables are difficult to quantify.

## **7.7 SUGGESTIONS FOR FURTHER STUDY**

This study investigated the factors influencing SME financing by banks in South Africa. The findings of the study suggest that credit supply to SMEs hinges on lending technology, collateral, credit worthiness and transaction costs. Although this study advances the understanding of the relationship between banks and SMEs, much work remains for future research. Notably, the study could be extended to other financial institutions. Bearing in mind the importance of the SME sector to the development of the economy, the influence that the government could have on this issue could also be investigated.

While this study has succeeded in addressing several issues pertaining to SME financing, there may still be certain issues that require further research. For example, a longitudinal field survey may yield additional results, especially on the trends of SME financing over time. Another research angle would be to focus on the effects of risk management and SME-bank relationships on SME financing at the regional level, which could contribute to the body of knowledge of the credit rationing behaviour by banks. This study was limited to a selection of banks and SMEs in the Gauteng province and therefore the results can not be generalised to the rest of South Africa. It will be interesting to repeat the empirical part of the research with a geographically representative dataset of SME's and banks from all the nine provinces of South Africa.



Arguably, the application of FICA and the NCA regulations commingled with peculiar challenges that should be addressed through policy amendments and other relevant interventions. Further research is required to understand the specific impact of FICA and the NCA on investors in financial institutions like banks, as well as similar policies in other parts of the world.

## **7.8 FINAL CONCLUSION**

Contrary to the general view that commercial banks are disinclined to providing credit to SMEs, the study established that South African banks are keen to serve the SMEs and are therefore making efforts to penetrate this market segment. The results of the study indicate that banks consider the SME sector as a strategically profitable economic sector. However, several obstacles are holding back further involvement of banks with SMEs in South Africa. These include inherent SME characteristics such as information asymmetry and inability to post adequate collateral; problems of an organisational nature such as difficulty in standardising products and procedures (screening, origination, monitoring and risk management); inability to diversify risk across SME borrowers and high transaction costs; and lastly macroeconomic factors such as high interest rates.

According to the study, the determinants of credit supply to SMEs are collateral, creditworthiness, and transaction costs. The study also identified unconventional factors such as lending technology and innovative strategies as significant predictors of credit supply to SMEs in South Africa. From the demand-side, the results of the study identified creditworthiness, collateral, information asymmetry and technology (e-banking) to be important predictors of SME access to bank credit. It can be noted that collateral, creditworthiness and technology are significant factors for both the supply of bank credit to SMEs and the access of bank finance by SMEs. This implies that banks should strive to align their lending techniques with the dynamic technological developments so as to reach as many SMEs as possible even in the geographically dispersed regions. Ensuring cost-effective technology, enabling access to comprehensive and reliable information, and the securitisation and realisation of collateral are fundamental challenges that banks should address in order to service SMEs more effectively. It is foreseen that improving SME access to

bank credit could be a key to the growth and sustainability of SMEs, the alleviation of poverty and unemployment; and consequently leading to the growth of the South African economy.

## REFERENCES

- Abdulsaleh, A. M. and Worthington, A.C. 2013. Small and Medium-Sized Enterprises Financing: A Review of Literature, *International Journal of Business Management*, 8 (14): 36-54.
- Abor, J. 2007. Capital Structure and Financing of SMEs: Empirical evidence from Ghana and South Africa. Dissertation presented for the degree of Doctor of Philosophy at the University of Cape Town.
- Abor, J. and Quartey, P. 2010. Issues in SME Development in Ghana and South Africa. *International Research Journal of Finance and Economics*, 39: 218-228.
- Abor, J., and Biekpe, N. 2007. Small Business Reliance on Bank Financing in Ghana. *Emerging Market Finance and Trade*, Vol. 43(4): 93-102.
- Act 102 of 1996. Republic of South Africa. National Small Business Act, no 102 of 1996, Government Gazette, 377, 17612.
- Akinboade, O.A. and Kinfaek, E.C. 2013. Financial Sector Development Indicators and Economic Growth in Cameroon and South Africa. *Social Indicators Research* DOI10.1007/s11205-013-0236-8
- Akuetteh, C.K 2009. Entrepreneurship and Bank Credit Rationing in Ghana. Thesis submitted in fulfilment of the degree of Doctor of Philosophy. Durham Business School, Durham University, United Kingdom.
- Alexander, P. 2013. Marikana, turning point in South African history. *Review of African Political Economy*, 40 (138): 605-609.
- Anderson, R., Babin, B., Black, W. & Hair, J. 2010. *Multivariate Data Analysis*. New Jersey: Pearson.

- Andree, C. and Kallberg, C. 2008. The capital structure of SMEs: Evidence from the Swedish security industry. [online]. Retrieved from: <http://www.student.se/uppsok/search2.php?allasmes>. [Accessed 20 May 2013]
- Angela Motsa and Associates. 2004. *SMME Finance Sector Background Paper: A review of key documents on SMME Finance 1994-2004*. Johannesburg.
- Angelini, P., Di Salvo, R. & Ferri, G. 1998. Availability and cost of credit for small businesses: Customer relationships and credit cooperatives. *Journal of Banking and Finance*, 22: 925-954.
- Aregbeshola, R.A. 2010. The effect of FICA on the shareholders' interest of listed automobile firms on the JSE.
- Ardic, O.P., Mylenko, N. & Saltane, V. 2011. Small and Medium Enterprises: A Cross-Country Analysis with a New Data Set. Policy Research Working Paper 5538, The World Bank.
- Arroyo, M.R. 2007. Information asymmetries, credit rationing and banking concentration: The Argentinean case. Centro Internacional de Formación Financiera. Madrid.
- Ashton, J. and Keasey, K., 2005. Competition and the Provision of Banking Services to SMEs in the U.K. *Small Business Economics*, 24: 477-485.
- Atieno, R. 2009. Linkages, access to finance and the performance of small-scale enterprises in Kenya. *Journal of Accounting and Business Research*, 3(1), 33-48.
- Atkinson, D. 2012. Review of the efficiency and effectiveness of past and on-going SME development initiatives in the Free State Province. Report 2. Literature Review. International labour Organisation.

- Ayyagari, M., Beck, T., & Demirgüç-Kunt, A. 2007. Small and Medium Enterprises across the Globe. *Small Business Economics*, 29: 415-434.
- Baas, T. and Schrooten, M. 2006. Relationship banking and SMEs: a theoretical analysis. *Small Business Economics*. 27 (2-3): 127-137.
- Babbie, E. 2011. *The Practice of Social Science Research*. South African Ed. Cape Town: Oxford University Press.
- Babbie, E. and Mouton, J. 2011. *The Practice of Social Science Research*. South African Ed. Oxford University Press.
- Baker, M. and Wurgler, J. 2002. Market Timing and Capital Structure. *The Journal of Finance*, 57(1): 1-32.
- Barbosa, E.G. and Moraes, C.C. 2004. Determinants of the firm's capital structure: The case of the very small enterprises. Available Online: [http://econpa.wustl.edu.8089/eps/fin/papers\\_0302/0302001.pdf](http://econpa.wustl.edu.8089/eps/fin/papers_0302/0302001.pdf) [Accessed 10 May 2014]
- Barclay, M.J. and Smith, C.W. 2005. The Capital Structure Puzzle: The Evidence Revisited. *Journal of Applied Corporate Finance*, 17(1): 8-17.
- Bates, S. L., 1989. Capital Structure Decisions in Privately held Firms. A Summary of Owner Interviews. Working Paper. College of Business Administration, University of Cincinnati, Cincinnati, OH, pp. 1-12.
- Barton, S.L., Ned, C.H. & Sundaram, S. 1989. An empirical test of stakeholder theory predictions of capital. *Financial Management*, 18 (1,): 36-44.
- Bates, T. 1990. Entrepreneur human capital inputs and small business longevity. *Journal of Economics and Statistics* 7(4): 551-559.

- Bbenkhele, K.E. 2007. An Investigation of Small and Medium Enterprises Perceptions towards Services Offered by Commercial Banks in South Africa. *African Journal of Accounting, Economics, Finance and Banking Research*, 1(1): 13-25.
- Beck, T., Demirguc-Kunt, A. & Levine, R. 2005. SMEs, Growth, and Poverty: Cross-Country Evidence. *Journal of Economic Growth*, 10(3): 199-229.
- Beck, T., and A. Demirgüç-Kunt 2005. Small and medium-size enterprises: overcoming growth constraints. Policy Research Working Paper, No. WPS3127. Washington, D.C.: World Bank.
- Beck, T., Demirgüç-Kunt, A. and Maksimovic, V. 2005. Financial and legal constraints to Growth: Does Firm Size Matter? *The Journal of Finance*, 60(1): 137-177.
- Beck, T., Demirgüç-Kunt, A. and Maksimovic, V. 2005. The influence of financial and legal institutions on firm size. *Journal of Banking & Finance*, 30(11): 2895-3015.
- Beck, T., Demirgüç-Kunt, A., Laeven, L., & Maksimovic, V. 2006. The Determinants of Financing Obstacles. *Journal of International Money and Finance*, 25(6): 932-952.
- Beck, T. and A. Demirgüç-Kunt 2006. Small and Medium–Size Enterprises: Access to Finance as a Growth Constraint. *Journal of Banking and Finance*, 30(11): 2931-2943.
- Beck, T., Demirguc-Kunt, A. & Martinez Peria, M.S. 2008. Bank Financing for SMEs around the World: Drivers, Obstacles, Business Models and Lending Practices. World Bank Policy Research Working Paper 4785.
- Bellier, A., Sayeh, W. & Serve, S. 2012. What lies behind credit rationing? A survey of the literature. Thema Working Paper No. 2012-39, Université de Cergy Pontoise, France

- Berg, G. and Fuchs, M. 2013. Bank Financing of SMEs in Five Sub-Saharan African Countries: The Role of Competition, Innovation and the Government. Policy Research Working Paper 6563, The World Bank.
- Berger, A.N. and Udell, G.F. 1990. Collateral, loan quality and bank risk. *Journal of Monetary Economics*, 25(1): 21-42.
- Berger, A.N. and Udell, G. F. 1995. Relationship lending and lines of credit in small firm finance. *The Journal of Business*, 68: 351-381.
- Berger, A.N and Udell, G.F. 1994. Lines of credit and relationship lending in small firm finance. The Wharton Financial Institution Center Working Paper 94-11
- Berger, A.N. and Udell, G.F. 2002. Small Business Credit Availability and Relationship Lending: The Importance of Bank Organisational Structure. *The Economic Journal*, 112 (477): F32-F53. Oxford, Blackwell Publishers.
- Berger, A.N., Frame, W.S. & Miller, N.H. 2005. Credit scoring and the availability, price, and risk of small business credit. *Journal of Money, Credit & Banking*, 37: 191-122.
- Berger, A.N. and Udell, G.F. 2006. A more complete conceptual framework for SME finance. *Journal of Banking and Finance*, 30(11): 2945-2968. Oxford, Blackwell Publishers.
- Berger, A.N. and Frame, W.S. 2007. Small business credit scoring and credit availability. *Journal of Small Business Management*, 46: 5-22.
- Berger, A.N. and Udell, G.F. 1998. The economics of small business finance: The roles of private equity and debt markets in the financial growth cycle. *Journal of Banking and Finance*, 22: 613-673.

- Berger, A.N. and Black, L. 2011. Bank size, lending technologies and small business finance, *Journal of Banking and Finance*, 35:724-735.
- Berry, A., M. von Blottnitz, R. Cassim, A. Kesper, B. Rajaratnam, & van Seventer, D. E. 2002. The Economics of SMEs in South Africa. *Trade and Industrial Policy Strategies*, Johannesburg, South Africa.
- Besanko, D. and Thakor, A.V. 1987. Collateral and credit rationing: Sorting equilibria in monopolistic and competitive credit markets. *International Economic Review*, 28(3): 671–689.
- Bester, H. 1985. Screening vs. Rationing in Credit Markets with Imperfect Information. *The American Economic Review*, 75(4): 850-855.
- Bhaird, C. M. A. and Lucey, B. 2006. Capital structure and the financing of SMEs: Empirical evidence from an Irish survey, Working paper for conference Entrepreneurship: occupational choice and financing. Copenhagen: Centre for Economic and Business Research.
- Bhaird, C.M., and Lucy, B. 2008. Determinants of capital structure in Irish SMEs. *Small Business Economics*, 4(2): 310-326.
- Binks, M. R. and Ennew, C. T. 1996. Growing firms and the credit constraint. *Small Business Economics*, 8(1): 17-25.
- Blumberg, B.F. and Letterie, W.A. 2008. Business starters and credit rationing in small business. *Small Business Economics*, 3(1): 187-200.
- Bolton, J. E. (1971). *Small Firms*, Report of the Committee of inquiry on Small Firms, HMSO, London.
- Boot, A. W. A. and Thakor, A.V. 1994. Moral Hazard and Secured Lending in an Infinitely Repeated Credit Market Game. *International Economic Review*, 35: 899-920.



- Brace, I. 2008. *Questionnaire Design: How to Plan, Structure, and Write Survey material for Effective Market Research*, 2<sup>nd</sup> ed. London: Kogan Page.
- Bradley, N. 2007. *Marketing research, tools and techniques*. New York: Oxford.
- Brierley, N. 2001. The financing of technology-based small firms: A review of the literature. *Bank England Quarterly Bulletin*, 41(1): 64-78.
- Brink, A., Cant, M. and Ligthelm, 2003. Problems experienced by small businesses in South Africa. A paper for the Small Enterprise Association of Australia and New Zealand 16th Annual Conference, Ballarat, 28 Sept-1 Oct, 2003.
- Bruns, V. and Fletcher, M. 2008. Banks' risk assessment of Swedish SMEs, Venture capital: *International Journal of Entrepreneurial Finance*, 10(2): 171-194.
- Burney, S.M.A. 2008. Inductive and Deductive Research Approach. Briefing prepared for the Department of Computer Science, University of Karachi, 3/6/2008.
- Byiers, B.R., Tarp, F. and Bentzen, J. S. 2010. Credit demand in Mozambican manufacturing. *Journal of International Development*, 22(1): 37-55.
- Calice, P., Chando, M. & Sekioua, S. 2012. Bank Financing to Small and Medium Enterprises in East Africa: Findings of a Survey in Kenya, Tanzania, Uganda and Zambia.
- Carbó, S., Rodríguez, F. and Udell, G.F. 2011. Bank Market Power and SME Financing Constraints, *Review of Finance*, 13: 309-340.
- Carpenter, R.E. and Petersen, B.C. 2002. Capital market imperfections, high-tech investment, and new equity financing. *Economic Journal*, 112: F54–F72.

- Cassar, G. 2004. The financing of business start-ups. *Journal of Business Venturing*, 19 (2): 261-283.
- Cassar, G. and Holmes, S. 2003. Capital structure and financing of SMEs: Australian evidence. *Journal of Accounting and Finance*, 43: 123-147.
- Castelli, A., Dwyer, G.P. & Hasan, I. 2006. Banking Relationships and Small Firms Financial Performance. Federal Reserve Bank of Atlanta. Working paper Series No. 2006-5, pp. 1-28.
- Chakravarty, S., and Yilmazer, T. 2008. A multistage model of loans and the role of relationships. *Financial Management* (forthcoming), Available at <http://www.fma.org/forthcomingfm.htm>
- Chironga, M., Dahl, J., Goland, T., Pinshaw, G. and Marnus, S. 2010. Micro-, small and medium-sized enterprises in emerging markets: how banks can grasp a \$350 billion opportunity. McKinsey & Company.
- Chittenden, F., Hall, G. & Hutchinson, P. 1996. Small firm growth, access to capital markets and financial structure: Review of issues and an empirical investigation. *Small Business Economics*, 8(1): 59-67.
- Cieply, S. and Dejardin, M. 2010. Entrepreneur Finance in France: The persistent role of banks. in J. Bonnet, D. García-Pérez-de-Lema, and E. Van Auken (eds.) *The Entrepreneurial Society: How to Fill the Gap between Knowledge and Innovation* (pp. 54–79). Cheltenham: Edward Elgar Publishing.
- Coco, G. 2000. On the use of collateral. *Journal of Economic Surveys*, 14(2):191-214.
- Cole, R. A. 1998. The importance of relationships to the availability of credit. *Journal of Banking and Finance*, 22(6-8): 959–977.

- Cole, R.A. 2011. Bank Credit, Trade Credit or No Credit: Evidence from the Surveys of Small Business Finances. Unpublished manuscript, available at SSRN. <http://ssrn.com/abstract=1540221>, [Accessed 1 December 2012].
- Coleman, S. and Cohn, R. 2000. Small firm's use of financial leverage: evidence from 1993 national survey of small business finances. *Journal of Business Entrepreneurship*, 12(3): 81-98.
- Collis, J. and Hussey, R. 2009. *Business research: a practical guide for undergraduate and postgraduate students*. 3rd ed. New York: Palgrave Macmillan.
- Colquitt, J. 2007. *Credit Risk Management: How to Avoid Lending Disasters and Maximize Earnings*. 3rd ed. McGraw-Hill. USA.
- Cook, P. and Nixon, F. 2000. Finance and Small and Medium-Sized Enterprise Development. IDPM. University of Manchester, Finance and Development Research Programme Working Paper Series, Paper No. 14.
- Cooper, D.R., and Schindler, P.S. 2008. *Business Research Methods*. 12th ed. New York: McGraw Hill Inc.
- Creswell, J.W. 2009. *Qualitative inquiry and research design: Choosing among among five approaches*. 2<sup>nd</sup> Ed. Thousand Oaks, CA: Sage Publications.
- Creswell, J.W. 2014. *Research Designs: Qualitative, Quantitative, and Mixed Method Approaches*. 4<sup>th</sup> Ed. California; Sage Publications.
- Dabo, D.D. 2006. Financing small and medium-sized enterprises in Nigeria. (PhD) thesis, Loughborough University.
- Daskalakis, N. and Psillaki, M. 2009. Are the determinants of capital structure country or firm specific? *Small Business Economics*, 33(3): 319-333.

- Deakins, D., Whittam, G & Wyper, J. 2010. SMEs' access to bank finance in Scotland: an analysis of bank manager decision making, *Venture Capital*, 12(3): 193-209.
- Debabneh, R. and Tukan, F. 2007. *Booklet of Standardised Small and Medium Enterprises Definition – 2007*. United States Agency for International Development.
- DeGennaro, R. P. 2005. Market imperfections. *Journal of Financial Transformation*, Capco Institute, 14: 107-117.
- Degryse, H., de Goeij, P. & Kappert, P. 2012. The impact of firm and industry characteristics on small firms' capital structure. *Small Business Economics*, 38: 431-477. DOI 10.1007/s11187-010-9281-8
- Deesomsak, R., Paudyal, K. & Pescetto, G. 2004. The determinants of capital structure: evidence from the Asia Pacific region. *Journal of Multinational Financial Management*, 14(4-5): 387-405.
- De la Torre, A., Martinez Peria, M.S. & Schmukler, S.L. 2008. Bank Involvement with SMEs: Beyond Relationship Lending. *Journal of Banking and Finance*, 34: 2280-2293.
- De Meza, D. and Webb, D. 1987. Too Much Investment: a Problem of Information asymmetry. *The Quarterly Journal of Economics*, 102: 281-292.
- Demirguc-Kunt, A, Maksimovic, V, Beck, T. & Laeven, L. 2006. The determinants of financing obstacles. *International Journal of Money and Finance*, 25 (6): 932-52.
- Denzin, N.K. and Lincoln, Y.S. 2011. *The SAGE Handbook of Qualitative Research*. London, SAGE Publications Inc.

Department of Trade and Industry. 2005. *Integrated Strategy in the Promotion of Entrepreneurship and Small Enterprises*. Department of Trade and Industry.

Department of Trade and Industry. 2008) *Annual review of small business in South Africa 2005-2007*. Department of Trade and Industry.

Department of Trade and Industry (DTI). 2009. Mandisi Mpahlwa. General Notice of 2009. *Annual Review of Small Business in South Africa*.

Department of Trade and Industry. 2011. *Annual Review of Small Business in South Africa*. Pretoria. DTI - Enterprise Development Unit. Available at. <http://www.dti.gov.za/seda> (Accessed on 20 October 2012).

De Souza, Z. and Dick, G.W. 2009. Disclosure of information by children in social networking – Not just a case of “you show me yours and I will show you mine”. *International Journal of Information*, 29: 255-261.

Diamond, D.W. 1991. Optimal Release of information By Firms. *The Journal of Finance*, 40(4): 1071-1094.

Diamond, D. W. (1989) Reputation acquisition in debt markets. *Journal of Political Economy*, 97: 828- 862.

Diamond, D.W. 1984. Financial Intermediation and Delegated Monitoring. *The Review of Economic Studies*, 51(3): 393-414.

Dion, P.A. 2008. Interpreting structural equation modelling results: A reply to Martin and Cullen. *Journal of Ethics*, 83: 365-368.

Dollinger, M. J. 1995. *Entrepreneurship: Strategies and Resources*. Wellesley, MA: Irwin, Babson College, pp.131-144.

- Drakos, K. and Giannakopoulos, N. 2011. On the determinants of credit rationing: Firm-level evidence from transition economies. *Journal of International Money and Finance*, 30: 1773-1790
- Du, J., Guariglia, A. and Newman, A. 2010. Does Social Capital Affect the Financing Decisions of Chinese Small and Medium-Sized Enterprises?
- Dutta, D. and Magableh, I. 2006. A socio-economic study of the borrowing process: The case of micro entrepreneurs in Jordan. *Applied Economics*, 38 (14): 1627-1640.
- Easterby-Smith, M., Thorpe, R., Jackson, P. and Lowe, A. 2008. *Management Research*. 3rd ed. London: Sage.
- Ebrahim, N.A., Ahmed, S. & Taha, Z. 2010. Virtual R&D teams and SME growth: A comparative study between Iranian and Malaysian SMEs. *African Journal of Business Management*, 4: 2368-2379.
- Ehlers, M.B. and Lazenby, J.A.A. 2007. *Strategic Management: Southern African concepts and cases*. 2nd ed. Pretoria: Van Schaik.
- Eikebrokk, T.R. and Olsen, D.H. 2007. An empirical investigation of competency factors affecting e-business success in European SMEs. *Information and Management*, 44: 364-383.
- Ejembi, S.A. and Ogiji, P. 2007. "A comparative analysis of risks and returns of running small/medium and micro enterprises in North and Central Nigeria", *Journal of Social Science*, 15(1): 7-15.
- Esperanca, J.P., Ana, P.M.G. & Mohamed, A.G. 2003. Corporate debt policy of small firms: an empirical (re)examination. *Journal of Small Business and Enterprise Development*, 10(1): 62-80.

- Falkena, H., Abedian, I., Blottnitz, M., Coovadia, C., Davel, G., Madungandaba, J., Masilela, E. & Rees, S. 2001. "SMEs' Access to Finance in South Africa, A Supply-Side Regulatory Review", The Task Group of the policy Board for Financial Services and Regulation. Available from: [www.finance.gov.za/documents/smes](http://www.finance.gov.za/documents/smes). [Accessed 18 November 2012].
- Fatoki, O. and Aregbeshola, R.A. 2013. *SMEs, financial Reporting and Trade Credit: An International Study*. Certified Accountants Educational Trust: London.
- Fatoki, O. and Van Aardt, A. 2011. Constraints to Credit Access by New SMEs in South Africa: A supply-side analysis. *African Journal of Business Management*, 5(4): 1413-1425.
- Fatoki, O. 2012. The impact of Entrepreneurial Orientation on Access to Debt Finance and Performance of Small and Medium Enterprises in South Africa. *Journal of Social Science*, 32(2): 121-131.
- Fatoki, O. 2010. The Impact of the South African Business Environment on the availability of Debt Finance to New SMEs, Unpublished PHD Dissertation, University of the Free State
- Fatoki, O. and Odeyemi, A. 2010. Which New Small and Medium Enterprises in South Africa Have Access to Bank Credit? *International Journal of Business and Management*, 5(10): 128-136.
- Fatoki, O. and Garwe, D. 2010. Obstacles to the growth of new SMEs in South Africa: A principal component analysis approach. *African Journal of Business Management*, (5): 729-738.
- Fatoki, O. and Odeyemi, A. 2010. The determinants of access to trade credit by new SMEs in South Africa. *African Journal of Business Management*, 4(13): 2763-2770.

- Fazzari, S.M., Hubbard, R.G. & Petersen, B.C. 1988. Financing Constraints and Corporate Investment, *Brookings Papers on Economic Activity*, (1): 141-195.
- Fellows, R. and Liu, A. 2008. *Research methods for construction*, 3rd ed, Chichester, Wiley-Blackwell.
- Fenwick, L.J. and Lyne, M.C. 1998. Factors influencing internal and external credit rationing among small-scale farm households in Kwazulu-Natal. *Agrekon*, 37(4): 495-504.
- Field, A. 2009. *Discovering Statistics Using SPSS*, Sage Publications Inc, Thousand Oaks, CA.
- Finlayson, J.A. 2003. Gauging the Economic Contribution of Large and Small Businesses - Reassessment. *Policy Perspective*, 10(4): 1-5.
- FinMark Trust. 2006. Fin scope small business survey. [Online]. Available: <http://www.finmarktrust.org.za> [Accessed: 25 April 2011]
- Forte, D., Barros, L.A. & Nakamura, W.T. 2013. Determinants of the Capital Structure of Small and Medium Sized Brazilian Enterprises, *BAR – Brazilian Administration Review*, 10(3): 347-369.
- Frank, M.Z and Goyal, V.K. 2003. Testing the pecking order theory of capital structure. *Journal of Financial Economics*, 67: 217-248.
- Freel, M. 2007. Are small innovators credit rationed? *Small Business Economics*, 28: 23–35.
- FinMark Trust. 2006. FinScope Small Business Survey [online]. Available from: <http://www.finmarktrust.org.za> [Accessed: 25 April 2012].



- Foxcroft, M., Wood, E., Kew J., Herrington, M. & Segal, N. 2002. *Global Entrepreneurship Monitor, South African Executive Report*, Graduate School of Business: University of Cape Town.
- Frelinghaus, A., Mostert, B. & Firer, C. 2005. Capital structure and the firm's life stage. *South African Journal of Business Management*, 36(4): 9-18.
- Ganbold, B. 2008. Improving Access to Finance: International Good Experiences and Lessons for Mongolia. No. 438.
- Garriga, J.M. 2006. Relationship Lending and Small Business Finance: Empirical Analysis of Cost of Capital, Credit Rationing, and Firm Performance. Economics and Business Department, Universitat Pompeu Fabra, Barcelona.
- Garwe, D. and Fatoki, O. 2012. The impact of gender on SME characteristics and access to debt finance in South Africa. *Development Southern Africa*, 29(3): 448-461.
- George, D. and Mallery, P. 2003. *SPSS for Windows step by step: A simple Guide and reference 11.0 update* (4th ed.). Boston: Allyn & Bacon.
- Giannetti, C. 2012. Relationship Lending and Firm Innovativeness. *Journal of Empirical Finance*, doi: 10.1016/j.jempfin.2012.08.005.
- Gildert, S. 2009. Risk-reward and the SME-lending imperative. An Experian briefing paper.
- Gill, J. and Johnson, P. 2010. *Research Methods for Managers*, 4<sup>th</sup> ed. London: Sage.
- Gitman, L. 2009. *Principles of Managerial Finance*. Addison Wesley, New York.

- Gliem, J.A. and Gliem, R.R. 2003. Calculating, interpreting, and reporting Cronbach's alpha reliability coefficient for Likert-type scales, Midwest research to practice conference in adult, continuing, and community education.
- Gray, P.S., Williamson, J.B., Karp, D.A. & Dalphin, J.R. 2007. *The research imagination: an introduction to qualitative and quantitative methods*. New York: Cambridge.
- Green. A. 2003. Credit Guarantee Schemes for Small Enterprises: An Effective Instrument to Promote Private Sector-Led Growth, the United Nations Industrial Development Organization (UNIDO) Working Paper No. 10, August 2003.
- Global Entrepreneurship Monitor (GEM) 2008. Report on Higher Expectation Entrepreneurship from: [www.gemconsortium.org](http://www.gemconsortium.org) [Accessed on 3 June 2012].
- Global Entrepreneurship Monitor (GEM). 2010. 2010. Report on Higher Expectation Entrepreneurship from: [www.gemconsortium.org](http://www.gemconsortium.org) [Accessed on 1 June 2012].
- Gordon Institute of Business Science (n.d.). The Entrepreneurial Dialogues: State of Entrepreneurship in South Africa. [Online] Available from <http://www.gibs.co.za/SiteResources/documents/The%20Entrepreneurial%20Dialogues%20-0State%20of%20Entrepreneurship%20in%20South%20Africa.pdf> [Accessed 02 February 2013]
- Government Gazette of the Republic of South Africa. 2003. National Small Business Amendment Act (26) of 2003.
- Hair, J., Black, W., Babin, B. & Anderson, R., 2014. *Multivariate Data Analysis*, 7<sup>th</sup> ed. Pearson Prentice Hall, Auflage.
- Hair, J.F., Black, W.C. Babin, B.J., Andersen, R.E. & Tatham, R.L. 2006. *Multivariate Data*, 6<sup>th</sup> ed., Prentice Hall, Upper Saddle River, NJ.

- Hall, G.C., Hutchinson, P.J. & Michaelas, N. 2004, Determinants of the capital structures of European SMEs. *Journal of Business Finance and Accounting*, 31 (5/6): 711-28.
- Halov, N. and Heider, F. 2011. Capital Structure, Risk and Information asymmetry. *Quarterly Journal of Finance*, 1(4): 767-809.
- Harris, M. and Raviv, A. 1991. "The theory of capital structure", *Journal of Finance*, 46(1): 297-355.
- Hartarska, V. and Gonzalez-Vega, C. 2006. What affects new and established firms' expansion? Evidence from small firms in Russia. *Small Business Economics*, 27(2): 195-206.
- Hashi, I. and Toçi, V.Z. 2010. Financing constraints, credit rationing and financing obstacles: Evidence from firm-level data in South-Eastern Europe. *Economic and Business Review*, 12(1):29–60.
- Hernandez-Canovas, G. & Martinez-Solano, P. 2010. Relationship lending and SME financing in the continental European bank-based system. *Small Business Economics*, 34(40): 465-482.
- Herrington, M., Kew, J. & Kew, P. 2009. Tracking Entrepreneurship in South Africa: a GEM perspective [Online]. Available: <http://www.gemconsortium.org/article> (6 September 2012).
- Hoff, K. and Stiglitz, J.E. 1990. Introduction: Imperfect Information and Rural Credit Markets – Puzzles and Policy Perspectives. *The World Bank Economic Review*, 4(3): 235-250.
- Hollensen, S. (2003) *Marketing Management: A Relationship Approach*. Financial Times Prentice Hall, Harlow.

- Hooper, D., Coughlan, J. & Mullen, M. 2008. Structural Equation Modelling: Guidelines for Determining Model Fit. Dublin Institute of Technology.
- Huang, G. and Song, F.M. 2006. The determinants of capital structure: Evidence from China. *China Economic Review*, 17(1): 14-36.
- Hutchinson and Xavier: 2006. Comparing the impact of credit constraints on the growth of SMEs in a transition country with an established market economy. *Small Business Economics*, 27 (1): 169-79.
- Inderst, R. and Mueller, H.M. 2007. A lender-Based Theory of Collateral, *Journal of Financial Economics*, 84 (3): 826-859.
- Irwin, D. and Scott, J.M. 2010. Barriers faced by SMEs in raising bank finance. *International Journal of Entrepreneurial Behaviour & Research*, 16 (3): 245-259.
- Jaffee, D.M. and Russell, T. 1976. Imperfect information, uncertainty, and credit rationing. *Quarterly Journal of Economics*, 90: 651-66.
- Jaffee, D. and Stiglitz, J. 1990. Credit rationing. In B.M. Friedman and F.H. Hahn (eds.) *Handbook of Monetary Economics*, 2: 837–888. Amsterdam: North–Holland.
- Jensen, M. C. and Meckling, W. H. 1976. Theory of the firm: Managerial behaviour, agency costs and ownership structure. *Journal of Financial Economics*, 3(4): 305-360.
- Johannesburg Securities Exchange (JSE). (2009). [Online]. Available at: [www.jse.co.za/content/JSEProcessItems/AltX%20Listing%20Requirements.pdf](http://www.jse.co.za/content/JSEProcessItems/AltX%20Listing%20Requirements.pdf) [Accessed, 12 October, 2012].
- Jöreskog, K. and Sörbom, D. (1993) LISREL 8: Structural Equation Modeling with the SIMPLIS Command Language. Chicago, IL: Scientific Software International Inc.

- Kaiser, H.F. 1958. The varimax criterion for analytic rotation in factor analysis. *Psychometrika*, 23(3): 187-200.
- Kaplan, R. and Saccuzzo, D. 2008. *Psychological Testing: Principles, Applications and Issues*. 7<sup>th</sup> Ed. Belmont, CA: Wadsworth Cengage Learning.
- Kayanula, D. and Quartey, P. 2000. The Policy Environment for Promoting Small and Medium-Sized Enterprises in Ghana and Malawi, Finance and Development Research Programme, Working Paper Series, Paper No 15, IDPM, University of Manchester.
- Khan, R.E.A. and Hussain, T. 2011. Demand for formal and informal Credit in Agriculture: A case study of Cotton Growers in Bahawalpur. *Interdisciplinary Journal of Contemporary Research in Business*, 2(10): 308-314.
- Kim, W.S and Sorensen, E.H. 1986. Evidence on the impact of the Agency Costs of Debt on Corporate Debt Policy. *Journal of Financial and Quantitative Analysis*, 21 (2): 131-144.
- Kira, A.R. and He, Z. 2012. The Impact of Firm Characteristics on Access of Financing by Small and Medium-sized Enterprises in Tanzania. *International Journal of Business Management*, 7(24): 108-119.
- Kline, R. 2005. *Principles and Practice of Structural Equation Modelling*, 2<sup>nd</sup> ed., New York: Guilford Press.
- Klinger, B., Castro, L., Szenkman, P. & Khwaja, A. 2013. Unlocking SME Finance in Argentina with Psychometrics. Inter-America Development Bank, Technical Note No. IDB-TN-532.
- Kolb, B. 2008. *Marketing Research: A Practical Approach*. Thousand Oaks. London: Sage Publications.

- Kongolo, M. 2010. Job creation versus job shedding and the role of SMEs in economic development. *African Journal of Business Management*, 4 (11): 2288-2295.
- Kraus, A. and Litzenberger, R.H. 1973. A State-Preference Model of Optimal Financial Leverage. *Journal of Finance*, 28(4): 911-922).
- Krejcie, R.V. and Morgan, D.W. 1970. Determining sample size for research activities. *Educational and Psychological Measurement*, 30: 607-610.
- Kushnir, K. 2010. "How Do Economies Define MSMEs?" IFC and the World Bank [online]. Available from: <http://www.ifc.org/msmecountryindicators> [Accessed 23 June 2013].
- Kundid, A. and Ercegovac, R. 2011. Credit rationing in financial distress: Croatia SMEs' finance approach. *International Journal of Law and Management*, 53(1): 62-84.
- Lapar, M.L.A. and Graham, D. H. 1988. "Credit Rationing Under a Deregulated Financial System". Working Paper Series No. 88 – 19, <http://www3.pids.gov.ph/ris/wp/pidswp8819.pdf>
- Ledesma, R.D. and Valero-Mora, P. 2007. Determining the Number of Factors to Retain in EFA: an easy-to-use computer program for carrying out Parallel Analysis. *Practical Assessment, Research & Evaluation*, 12(2):1-11. ISSN 1531-7714.
- Leedy, P.D and Omrod, J.E. 2010. *Practical Research: Planning and Design*. 9th ed. Boston, MA: Pearson Education.
- Leedy, P.D and Omrod, J.E. 2014. *Practical Research: Planning and Design*. 10<sup>th</sup> Ed. Boston, MA: Pearson Education.

- Levitsky, J. and R. Prasad. 1987. Credit Guarantee Schemes for Small and Medium Enterprises. World Bank Technical Paper No. 58, Industry and Finance Series. The World Bank, Washington, D. C.
- Levy, B. 1993. Obstacles to Developing Indigenous Small and Medium Enterprises: An Empirical Assessment. *The World Bank Economic Review*, 7(1): 65-83.
- Levenson, A.R. and Willard, K.L. 2000. Do firms get the Financing they want? Measuring credit rationing experienced by small businesses in the US. *Small Business Economics* 14(1): 83-94.
- Li, K., Yue, H., & L. Zhao 2009. Ownership, institutions, and capital structure: Evidence from China. *Journal of Comparative Economics* 37(3): 471-490.
- Lucey, B.M. 2010. Determinants of capital structure of Irish SMEs. *Small Business Economics*, 35(3): 1-25.
- Luqman, A. and Abdullah, N.K. 2011. E-business adoption amongst SMEs: A Structural Equation Modelling Approach. *Journal of Internet Banking and Commerce*, 16(2): 1-20.
- Mahadea, D. and Pillay, M. 2008. Environmental conditions for SMME development in a South African province. *South African Journal of Economic and Management Sciences*, 11(4): 431-448.
- Malhotra, N.K. 2004. *Marketing research: an applied orientation*. 4th ed. Upper Saddle River, NJ: Pearson Education.
- Malhotra, M., Chen, Y., Criscuolo, A., Fan, Q., Hamel, I.I. & Savchenko, Y. 2006. *Expanding Access to Finance: Good Practices and Policies for Micro, Small and Medium Enterprises*. Washington DC. The World Bank Press.
- Marcus, J. 2012. Monetary policy and inflationary challenges in the face of the global economic crisis. Paper presented at the Numsa's 9<sup>th</sup> National Conference,

Johannesburg. Retrieved from <http://www.numsa.org.za/article/monetary-policy-and-inflationary-challenges-in-the-face-of-the-global-economic-crisis-2012-06-21>.

Maredza, A. and Ikhide, S. 2013. The Impact of Global Financial Crisis on Efficiency and Productivity of the Banking System in South Africa. Economic Research Southern Africa (ERSA) Working Paper 328.

McGivern, Y. 2006. *The practice of market and social research: an introduction*. 2nd ed. London: Prentice Hall.

Michaelas, N., Chittenden, F. & Poutziouris, P. 1999. Financial policy and capital structure choice in UK SMEs: empirical evidence from company panel data. *Small Business Economics*, 12(2): 113-30.

Migiro, S.O. 2005. Small and Medium-scale Manufacturing enterprises in Kenya: A perspective on alternative sources of financing. Thesis submitted in fulfillment of the requirements for the award of the Degree of Doctor of Commerce in Management at the University of Zululand. KwaDlangezwa.

Ministry of Economic Development. 2011. Small Firms in New Zealand: Structure and Dynamics 2011. Wellington: Ministry of Economic Development.

Modigliani, F and Miller, M.H. 1958. The Cost of Capital, Corporation Finance and the Theory of Investment. *American Economic Review*, 48(3): 261-295.

Modigliani, F. and Miller, M.H. 1963. Corporate Income Taxes and the Cost of Capital: A Correction. *American Economic Review*, 53(3): 433-444.

Moosa, I. 2007. Operational Risk: A Survey. *Financial Markets, Institutions and Instruments*, 16 (4): 167-200.  
<http://onlinelibrary.wiley.com/doi/10.1111/j.1468-0416.2007.00123.x/pdf>



- Musara, M. and Fatoki, O. 2012. Access to Finance in the SME Sector: A South African Perspective. *African Journal of Business management*, 4(1): 58-67.
- Mutezo, A. 2013. Credit rationing and risk management for SMEs: The way forward for South Africa. *Corporate Ownership & Control*, 10(2): 153-163.
- Mutezo, A.T. 2005. Obstacles in the access to SMME finance: an empirical perspective of Tshwane. Unpublished Masters Dissertation, University of South Africa.
- Myers, S.C. 1977. "Determinants of corporate borrowing", *Journal of Financial Economics*, 5(5): 147-75.
- Myers, S. 1984. The capital structure puzzle. *Journal of Finance*, 39(3): 575-592.
- Myers, S. C. and Majluf, N. S. 1984. Corporate financing and investment decisions when firms have information that investors do not have. *Journal of Financial Economics*, 13(2): 187-221.
- National Credit Regulator (NCR). 2011. Literature Review on Small and Medium Enterprises' Access to Credit and Support in South Africa (Pretoria: National Credit Regulator).
- Neuman, W.L. 2011. *Basics of Social Research: Qualitative and Quantitative Approaches*, 2<sup>nd</sup> Ed. Pearson Education.
- Newman, A. 2010. Capital Structure Determinants of Private Small and Medium-sized Enterprises in China. Thesis submitted to the University of Nottingham for the degree of Doctor of Philosophy
- Newman, A., Gunesse, S. & Hilton, B. 2013. The Applicability of Financial Theories of Capital Structure to the Chinese Cultural Context: A study of Privately-owned SMEs. *Small Business Journal*, 30(3): 65-83.

- Nieman, G. 2006. Small business management: A South African approach. Pretoria, Van Schaik.
- Nkuah, J.K., Tanyeh, J.P. & Gaeten, K. 2013. Financing Small and Medium enterprises (SMEs) in Ghana: Challenges and Determinants in Accessing Bank Credit, *International Journal of Research in Social Sciences*, 2 (3): 12-25.
- Nofsinger, J.R. and Wang, W. 2011. Determinants of start-up firm external financing worldwide. *Journal of Banking and Finance*, 35 (9): 2282-2294.
- Oja, K. and Pillay, K. 2009. Debt markets and corporate debt structure in an emerging market: The South African example. *Economic Modelling*, 26: 1215-1227.
- Okurut, F.N. and Botlhole, T. 2006. "Informal Financial Sector in Botswana: A Case Study of Gaborone City" Unpublished.
- Okurut, F.N., Olalekan, Y. & Mangadi, K. 2011. Credit Rationing and SME Development in Botswana: Implications for Economic Diversification. *Botswana Journal of Economics*, 8(12): 62-85.
- Organisation for Economic Cooperation and Development (OECD), 2007.
- Ortqvist, D., Mash, E. K., Rahman, S. F. & Selvarajah, C. 2006 Determinants of capital structure in new ventures: Evidence from Swedish longitudinal data. *Journal of Developmental Entrepreneurship*, 11(4): 277-296.
- Padachi, K., Narasimhan, M. S., Durbarry, R. & Howorth, C. 2008 An Analysis of Working Capital Structure and Financing Pattern of Mauritian Small Manufacturing Firms. *Journal of Applied Finance*, 14(7): 41-62.
- Padachi, K., Howorth, C. & Narasimhan, M.S. 2012. Working Capital Financing Preferences: The case of Mauritian manufacturing small and medium-sized

enterprises (SMEs). *Asian Academy of Management Journal of Accounting and Finance*, 8(1): 125-157.

Pallant, J 2010. *SPSS Survival Manual: A Step by Step Guide to Data Analysis using SPSS for Windows*, 4<sup>th</sup> ed. Open University Press

Pallant, J. 2005). *SPSS Survival Manual*, 2<sup>nd</sup> ed., Maidenhead: Open University Press.

Pang, P. 2008. The role of SMEs in Asian Development-Statement (From Kongolo).

Parker, S.C. and Van Praag, C.M. 2006. Schooling, capital constraints, and entrepreneurial performance. *Journal of Business and Economic Statistics*, 24(4): 416-431.

Parker, S.C. 2002. Do banks ration credit to new enterprises? And should governments intervene? *Scottish Journal of Political Economy*, 49(2): 162–195.

Parker, R., Riopelle, R & Steel, W. 1995. Small Enterprises Adjusting to Liberalisation in Five African Countries, World Bank Discussion Paper, No 271, African Technical Department Series, The World Bank, Washington DC

Peria, M.S.M. 2009. Bank financing to SMEs: What are Africa's specificities? SME financing in sub-Saharan Africa.

Petersen, M.A. and Rajan, R.G. 1994. The benefits of lending relationships: Evidence from small business data. *Journal of Finance*, 49: 3–37.

Petersen, M.A. and Rajan, R.G. 1997. Trade credit: Theories and Evidence. *Review of Financial Studies*, 10: 661-669.

Petter, S., Straub, D. and Rai, A. 2007. Specifying formative constructs in information systems research. *MIS Quarterly*, 31(4): 623-656.

- Quinlan, C. 2011. *Business Research Methods*. South Western Cengage Learning.
- Radipere, S.N and van Scheers, L.M. 2005. Perceptions of small business owners on managerial skills: problems in business development in South Africa. *World Review of Science, Technology and Sustainable Development*, 1741-2242.
- Rajan, R.G. 1992. Insiders and Outsiders: The Choice between Informed and arm's-Length Debt. *The Journal of Finance*, 47(4): 1367-1400).
- Ray, E.N. 2010. Small and Medium Enterprise (SME) Finance in South Africa: Implications for Private Sector-led Development. Submitted in partial fulfilment of the requirement for the degree of Master of Arts at Dalhousie University. Hali
- Robb, A. and Robinson, D.T. 2009. *The capital structure decision of new firms*. [Online]. Available from: [http://papers.ssrn.com/so13/papers.cfm?abstract\\_id=1345895](http://papers.ssrn.com/so13/papers.cfm?abstract_id=1345895) [Accessed on 30 October 2013]
- Rocha, R., Farazi, S.K.R. & Pearce, D. 2011. The status of Bank Lending in the Middle East and North Africa Region: The results of a Joint Survey of the Union of Arab Bank and the World Bank. *World Bank Policy Research Working Paper*, 5607. The World Bank, Washington DC.
- Rogerson, C.M. 2008. Tracking SMME development in South Africa: Issues of finance, training and the regulatory environment. *Urban Forum*, 19(1): 61-81.
- Romano, C.A., Tanewski, G.A. & Smyrniotis, K.X. 2001. Capital Structure Decision Making: A model for family business. *Journal of Business Venturing*, 16: 285-310.
- Rowe, J. 2008. "SME value and Contribution to UK Economy." Available from: [www.buzzle.com/.../sme-value-and-contribution-to-the-uk-economy.html](http://www.buzzle.com/.../sme-value-and-contribution-to-the-uk-economy.html) [Accessed on 18 August 2013]

- Salkind, N.J. 2012. *Exploring Research*. 8th ed. Upper Saddle River, NJ: Prentice Hall.
- Saunders, M., Lewis, P. & Thornhill, A. 2012. *Research Methods for Business Students*. Harlow: FT Prentice Hall.
- Schaper, M. 2010. *Making Ecopreneurs: Developing sustainable Entrepreneurship*. 2 ed. Surrey England: Gower Publishing Ltd.
- Sekaran, U. 2003. *Research methods for business*, 4th ed. Hoboken, NJ: John Wiley & Sons.
- Shane, S., and Cable, D. 2002. Network ties, reputation, and financing of new ventures. *Management Science*, 48(3): 364–381.
- Sharpe, S. 1990. Information asymmetry, Bank Lending and Implicit Contracts: A Stylized Model of Customer Relationships. *Journal of Finance*, 45: 1069-1087.
- Shikimi, M. 2013. Do firms benefit from multiple banking relationships? Evidence from small and medium- sized firms in Japan. *International Economic Policy*, 10: 127-157.
- Small Enterprise Development Agency (SEDA) 2010. Annual Report: 2010-2011.
- Small Enterprise Development Agency. 2008. The Importance of Small and Medium Enterprises (SMEs) in Economic Development. [Online]. Available at: [http://www.thefreelibrary.com/The+Importance+of+Small+and+Medium+Enterprises+\(SMEs\)+in+Economic...-a01073924138](http://www.thefreelibrary.com/The+Importance+of+Small+and+Medium+Enterprises+(SMEs)+in+Economic...-a01073924138)
- Sorgorb-Mira, F. 2005. How SME uniqueness affects capital structure: Evidence from a 1994-1998 Spanish data panel. *Small Business Economics*, 25(5): 447-457.

- Soufani, K. 2002. On the Determinants of Factoring as a Financing Choice: Evidence from the UK. *Journal of Economics and Business*, 54(2): 239-252.
- South African Police Service Crime Statistics. 2013 Crime Statistics [Online]. Available at: <http://www.saps.co.za> [August 2013].
- Statistics South Africa. 2013. Quarterly Labour Force Survey: Quarter 2 [Online]. Available from: [http://www.statssa.gov.za/publication/find\\_publication.asp](http://www.statssa.gov.za/publication/find_publication.asp) [Accessed 18 September 2013].
- StasSA (Statistics South Africa) 2014. Statistical release, P0441. Gross domestic Product. Available from: <http://Stassa.gov.za/publications/P0441/P04412ndQuarter2014.pdf> [Accessed on 15 October, 2014].
- Statistics Canada. 2007. Survey on Financing of Small and Medium Enterprises and Industry Canada.
- Stiglitz, J.E. and Weiss, A. 1981, "Credit rationing in Markets with Imperfect Information". *American Economic Review*, 71: 343-410.
- Steijvers, T. and Voordeckers, W. 2009 Collateral and credit rationing: A review of recent empirical studies as a guide for future research. *Journal of Economic Surveys*, 23(5): 924–946.
- Stephanou, C. and Rodriguez, C. 2008. Bank Financing to Small and Medium-Sized Enterprises (SMEs) in Colombia. Policy Research Working Paper 4481, The World Bank.
- Storey, D. J. 1994. The Role of Legal Status in Influencing Bank Financing and New Firm Growth. *Applied Economics*, 26(2): 129-136.
- Strydom, H. 2005. The pilot study. In De Vos, A. S., Strydom, H., Fouche, C.B. & Delport, C. S. L. : *Research at grassroots for the social service professions*. Pretoria: Van Schaik.

Su, Y. and Yang, C. 2010. A structural equation model for analyzing the impact of ERP on SCM. *Expert Systems with Applications*, 37: 456-469.

Sunday Times 2012.

Tabachnik, B. and Fidell, L. 2007. *Using Multivariate Statistics*, 5<sup>th</sup> ed., Boston: Pearson/Allyn & Bacon.

Timmons, J.A. and Spinelli, S. 2007. *New venture creation: Entrepreneurship for the 21st century*. Boston: McGraw Hill.

The South African Police Service. An Analysis of the National Crime Statistics 2012/2013.

Turyahebwa, A., Sunday, A. & Ssekajugo, D. 2013. Financial management practices and business performance of small and medium enterprises in western Uganda. *African Journal of Business Management*, 7(38): 3875-3885.

Tustin, D., Ligthelm, A., Martins, D. & Van Wyk, J. 2005. *Marketing Research in Practice*. Pretoria: Unisa University Press.

Uchida, H. 2011. What do banks evaluate when they screen borrowers? Soft Information, Hard Information and Collateral. *Journal of Financial Services Res*, 40: 29-48.

Uchida, H., Udell, G.F. & Yamori, N. 2011. What do banks evaluate when they screen borrowers? Soft information, hard information and collateral. *Journal of Financial Services Research*, 40(1/2): 29-48).

Uchida, H., Udell, G.F. and Yamori, N. 2012. Loan Officers and Relationship Lending to SMEs. *Journal of Financial Intermediation*, 21(1): 97-122.

- United Nations Economic Commission for Africa 2005. *Meeting the challenges of unemployment and poverty in Africa*. Addis Ababa.
- Van der Wal, DM. 2006. Factors eroding caring. *Africa Journal of Nursing and Midwifery*, 8(1): 55-75
- Voordckers, W. and Steijvers, T. 2006. Business collateral and personal commitments in SME lending. *Journal of Banking and Finance*, 30: 3067-3086.
- Voordckers, W. and Steijvers, T. 2008. Credit rationing for SME's in the corporate bank loan market of a bank-based economy. Working Paper, available at: [www.efmaefm.org/efma2005/papers/245-steijvers\\_paper.pdf](http://www.efmaefm.org/efma2005/papers/245-steijvers_paper.pdf) (Accessed 10 July 2012).
- Von Broembsen, M., Wood, E. & Herrington, E. 2008. *Global Entrepreneurship Monitor. The South African Report*. GEM, Cape Town.
- Vos, E., Yeh, A., Carter, S. & Tagg, S. 2007. The happy story of small business financing. *Journal of Banking and Finance*, 31(9): 2648-2672.
- Watson, J. and Newby, R. 2009. "Gender" and the SME "finance gap". *International Journal of Gender and Entrepreneurship*, 1(1): 42 – 56.
- Westhead, P and Storey, D.J. 1997. Financial constraints on the growth of high technology small firms in the United Kingdom. *Applied Financial Economics*, 7(2): 197-201.
- Winborg, J. and Landström, H. 2001. Financial bootstrapping in small businesses: Examining small business managers' resource acquisition behaviors, *Journal of Business Venturing*, 16(3): 235-254.
- World Bank, 2007a. Bank Financing to Small and Medium Enterprises: Survey Results from Argentina and Chile. Mimeo.



- World Bank, 2007b. Bank Lending to Small and Medium Enterprises: The Republic of Serbia. World Bank Country Study. The World Bank: Washington DC.
- World Bank 2008. Finance for all? Policies and Pitfalls in Expanding Access. World Bank Policy Research Report.
- Wu, J., Song, J. & Zeng, C. 2008. An Empirical Evidence of Small Business Financing in China. *Management Research News*, 31(12): 959-975.
- Yamane, T. 1967. *Statistics: An Introductory Analysis*, 2<sup>nd</sup> Ed, New York: Harper and Row.
- Yeboa, J., Asirifi, E.K. & Adigbo, E.D. 2014. The Role of Banks in Financing Small and Medium Scale Enterprises in Ghana – A Case Study of Universal Banks in Sekondi-Takoradi. *Journal of Education and Practice*, 5(11): 161-172.
- Young, J. 2006. Operational Risk Management: *The Practical Application of a Qualitative Approach*, Pretoria: Van Schaik.
- Zambaldi, F., Aranha, F., Lopes, H and Politi, R. 2009. Credit granting to small firms: A Brazilian case. *Journal of Business Research*, 64(3): 309-315.
- Zhou, W. 2009. Bank Financing in China's Private Sector: The Payoffs of Political Capital. *World Development*, 37(4),
- Zikmund, W. 2003. *Business Research Methods*, 7th ed., Mason, OH. and Great Britain, Thomson/South-Western.



## APPENDIX A: Bank Questionnaire

Resp.no.

### Small and Medium Enterprise Financing and Credit Rationing: The role of banks in South Africa

Dear respondent

Thank you for your willingness to participate in this survey. The purpose of the survey is to determine the factors that influence the availability of credit to small and medium enterprises (SMEs) and the credit risk management associated with SME financing. The survey should not take more than **30 minutes** to complete. This is an anonymous and confidential survey. You cannot be identified and the answers you provide will be used for academic research purposes only.

**Please answer all the questions as accurately as possible. Indicate your choice by marking the appropriate selected blank block with an "X".**

#### SECTION A: GENERAL INFORMATION

Q1. Years of experience in dealing with SME loan requests:

At most 2 years	1	
3-5 years	2	
6-10 years	3	
11-15 years	4	
Above 15 years	5	

Q2. Bank position occupied at present:

Banker	1	
Small Business Services (SBS) manager	2	
Relationship manager	3	
Credit manager	4	
Risk manager	5	
Supervisor	6	
Credit analyst	7	

Q3. Which of the following criteria does your bank use to define a SME?

Client size in terms of average sales	1	
Client size in terms of total assets	2	
Client size in terms of total employee	3	
Capital	4	
Other, specify	5	

**SECTION B: BANK INVOLVEMENT WITH SMES**

Q4. Does your bank have a separate unit responsible for managing SME relations?

Yes	1	
No	2	

Q5. What type of involvement do you have with SMEs?

The bank primarily offers deposits and cash management products	1	
The bank primarily offers loan product	2	
The bank offers both deposits and loan products	3	
Other, specify	4	

Q6. To what extent does your bank offer the following lending products to SMEs?

		Not to an extent at all	To a little extent	To some extent	To a large extent	To a very large extent
a	Term loans	1	2	3	4	5
b	Overdraft	1	2	3	4	5
c	Vehicle and asset finance	1	2	3	4	5
d	Credit cards	1	2	3	4	5
e	Home loan	1	2	3	4	5
f	Bond for factory/office premises	1	2	3	4	5

Q7. To what extent is your involvement with SMEs driven by the following?

		Not to an extent at all	To a little extent	To some extent	To a large extent	To a very large extent
a	Perceived profitability in the SME sector	1	2	3	4	5
b	Intense competition for large corporates	1	2	3	4	5
c	Intense competition for retail customers	1	2	3	4	5
d	Excessive exposure to large corporates	1	2	3	4	5
e	Excessive exposure to retail customers	1	2	3	4	5
f	Possibility to seek out SMEs through existing relations with large clients (e.g. reverse factoring)	1	2	3	4	5
g	For corporate social responsibility purposes	1	2	3	4	5

Q8. In your own opinion, indicate to what level the following factors are important **obstacles in lending** to SMEs.

		Not significant	Marginally significant	Significant	Very significant	Extremely significant
a	Increasing interest rates	1	2	3	4	5
b	Fluctuating exchange rate	1	2	3	4	5
c	Lack of adequate collateral	1	2	3	4	5
d	Information asymmetry	1	2	3	4	5
e	Bankruptcy regulations (e.g. Basel III)	1	2	3	4	5
f	FICA regulations	1	2	3	4	5
g	Inability of SMEs to manage risk	1	2	3	4	5
h	Interest rate ceilings imposed by regulation	1	2	3	4	5
i	Bank learning to do business with SMEs	1	2	3	4	5
j	High implementation and maintenance costs of lending technologies	1	2	3	4	5
k	Lack of adequate demand (there is demand but from customers that are not creditworthy)	1	2	3	4	5
l	Inability to diversify risk across borrowers	1	2	3	4	5
m	Difficulty in standardizing products and procedures (screening, origination, monitoring, risk management)	1	2	3	4	5

Q9. Indicate where the following activities normally occur when dealing with SMEs lending:

	Activity	Only done at headquarters	Only done at branches	Done primarily at headquarters	Done primarily at branches	Done at both HQ and branches
a	Loan pre-screening	1	2	3	4	5
b	Loan approval	1	2	3	4	5
c	Risk management	1	2	3	4	5
d	Non-performing loan recovery	1	2	3	4	5
e	Sale of non-lending products	1	2	3	4	5

Q10. Does your bank focus on dealing with SMEs in specific geographic areas?

Yes	1	
No	2	

Q11. Which particular criteria does the bank use to determine the SME clients it will target? **(Mark all applicable)**

Company size	1	
Geographic area where the firm operates	2	
Industry sector to which the firm belongs	3	
Product needs of the firm	4	
Expected profitability of the firm	5	
Exposure size	6	
Credit quality	7	

Q12. What types of products are offered to SMEs by your bank? **(Mark all applicable)**

Standardised (uniform)	1	
Tailored (designed to suit an individual customer)	2	
Both standardized and tailored	3	

Q13. To what extent is your bank aware of the following cost-reducing techniques in SME financing being implemented elsewhere in the world?

		Not at all aware	Slightly aware	Somewhat aware	Very aware	Extremely aware
a	Use of low-cost branches	1	2	3	4	5
b	Use of Correspondent banking	1	2	3	4	5
c	Use of contact centre models	1	2	3	4	5
d	Use of mobile phone-based products	1	2	3	4	5
e	Use of Laptop and Point of Sale (POS) -enabled agents	1	2	3	4	5

Q14. Indicate your level of agreement with the following statements relating to your bank's response to excess demand for credit by SMEs.

		Strongly disagree	Disagree	Neutral	Agree	Strongly agree
a	Increase interest rate to clear the excess demand					
b	Decline credit to customers because it is unprofitable at any interest rate	1	2	3	4	5
c	Increase collateral requirements to clear the excess demand	1	2	3	4	5
d	Keep interest rate low and randomly select loan applicants	1	2	3	4	5

**SECTION C: CREDIT RISK MANAGEMENT**

Q15. How is the credit risk management function organized in your bank?

Largely automated	1	
Done by the credit risk analyst	2	
Done by the relationship manager at the branch	3	
Done primarily at headquarters	4	

Q16. To what extent does your bank use the following lending technologies to screen SME loan applications?

		Not to an extent at all	To a little extent	To some extent	To a large extent	To a very large extent
a	Financial statement lending	1	2	3	4	5
b	Asset-based lending	1	2	3	4	5
c	Relationship-based lending	1	2	3	4	5
d	Leasing (property of the leased asset remains with the bank)	1	2	3	4	5
e	Factoring (business sells its accounts receivable to a third party at a discount.	1	2	3	4	5

Q17. Which of the following aspects characterize some of the ways the bank monitors credit risk over time for a particular SME? **(Mark all applicable)**

Automatically generated triggers	1	
Depends on the diligence of the Relationship Manager	2	
Depends on the diligence of the credit analyst	3	

Q18. Indicate your level of agreement on the use of the following measures by your bank to monitor SME activities.

		Strongly disagree	Disagree	Neutral	Agree	Strongly agree
a	Total debt outstanding	1	2	3	4	5
b	Repayment frequency	1	2	3	4	5
c	Regular reporting from the SME	1	2	3	4	5
d	Outstanding exposure	1	2	3	4	5

Q19. Indicate the nature of your bank's appetite by sector to extend finance to SMEs in the last five years:

		Increasing	Unchanging	Decreasing
a	Agriculture, forestry and fishing	1	2	3
b	Mining and quarrying	1	2	3
c	Manufacturing	1	2	3
d	Construction	1	2	3
e	Electricity, gas and water	1	2	3
f	Transport, storage and communications	1	2	3
g	Wholesale, retail trade, hotels and restaurants	1	2	3
h	Finance, insurance and business services	1	2	3

Q20. Please indicate your level of agreement with the following statements that describe your bank with respect to the screening of SME applications, where **1 = strongly disagree (SD)** and **5 = strongly agree (SA)**. The bank uses ...

	Statement	SD	D	N	A	SA
a	an increase in interest rate to screen applications.	1	2	3	4	5
b	increasing collateral to screen applications.	1	2	3	4	5
c	both interest rate and collateral requirements to screen loan applicants.	1	2	3	4	5
d	site visits to screen SMEs	1	2	3	4	5
e	personal interviews to screen SMEs	1	2	3	4	4
f	information from other banks to screen SMEs	1	2	3	4	5
g	third party evaluations to screen SMEs	1	2	3	4	5

Q21. Indicate your level of agreement to which you think the following factors lead to high transaction costs for SMEs for your bank where **1 = strongly disagree (SD)** and **5 = strongly agree (SA)**?

		SD	D	N	A	SA
a	High number of firms to investigate	1	2	3	4	5
b	The wide range of projects demanding specialized staff	1	2	3	4	5
c	High riskiness of the SMEs due to information asymmetry	1	2	3	4	5
d	Lack of standard accounting and auditing techniques	1	2	3	4	5

#### SECTION D: RELATIONSHIP LENDING

Q22. Indicate your level of agreement on how the bank-firm relationship helps to achieve the following objectives, where **1 = strongly disagree (SD)** and **5 = strongly agree (SA)**?

		SD	D	N	A	SA
a	Gather valuable information about the customer	1	2	3	4	5
b	Determine the customer's ability to pay	1	2	3	4	5



- Q23. To what extent does the approval of SME loan applications (availability of credit) depend on the following aspects of relationship lending?

		Not to an extent at all	To a little extent	To some extent	To a large extent	To a very large extent
a	Distance of the firm from the bank	1	2	3	4	5
b	The range of financial services purchased	1	2	3	4	5
c	Pre-existing relationship	1	2	3	4	5
d	Intended use of the loan	1	2	3	4	5

- Q24. To what extent are the following types of collateral important for your bank in approving loan applications?

		Not to an extent at all	To a little extent	To some extent	To a large extent	To a very large extent
a	Guarantee schemes in case of repayment default	1	2	3	4	5
b	Plant and equipment (e.g. machinery)	1	2	3	4	5
c	Vehicle asset	1	2	3	4	5

- Q25. Indicate your level of agreement with the following statements relating to SME lending where **1 = strongly disagree (SD)** and **5 = strongly agree (SA)**.

		SD	D	N	A	SA
a	Higher risk borrowers are willing to pledge higher interest rate with no collateral.	1	2	3	4	5
b	Pledging more collateral will not increase the supply of bank credit to SMEs.	1	2	3	4	5
c	Borrowers who already have current/saving accounts with our bank more easily comply with loan terms than first-time borrowers with no previous history with our institution.	1	2	3	4	5
d	Duration between a borrower and my bank is very important in availing credit facilities	1	2	3	4	5

- Q26. How would you rate the **importance** of the following factors in hindering the approval of SME loan applications?

		Very unimportant	unimportant	Neutral	Important	Very important
a	Perceived lack of profitability of the firm	1	2	3	4	5
b	<b>Inadequate</b> credit history of the firm	1	2	3	4	5
c	Lack of collateral to secure loan application	1	2	3	4	5
d	Poor cash flow projections	1	2	3	4	5
e	Lack of banking relationship	1	2	3	4	5

f	Capability of SME owner to partly fund the project	1	2	3	4	5
g	Compliance with the National Credit Act (NCA)	1	2	3	4	5
h	Education and experience of key management	1	2	3	4	5
i	Lack of financial literacy and business skills	1	2	3	4	5
j	Inadequate information to process loan applications	1	2	3	4	5

Q27. Indicate the level of extent to which the following innovative strategies (new technologies) have assisted in making your SME banking experience user friendly.

	Strategy	Not to an extent at all	To a little extent	To some extent	To a large extent	To a very large extent
a	Correspondent banking (Use of retailers to expand distribution)	1	2	3	4	5
b	Psychometric testing (using tests, profiles or a combination of the two to form a deeper understanding of the customer)	1	2	3	4	5

Q28. Please read the following statement carefully and then indicate your level of agreement with the factors that make SMEs risky enterprises for your bank to do business with **where 1 = strongly disagree (SD) and 5 = strongly agree (SA)**

	Statement	SD	D	N	A	SA
a	SMEs experience more variable rates of return than large firms	1	2	3	4	5
b	SMEs experience higher failure rates than large firms	1	2	3	4	5
c	SMEs are less equipped in human capital than large firms	1	2	3	4	5
d	SMEs are less equipped in terms of financial resources	1	2	3	4	5
e	SMEs use inadequate accounting systems	1	2	3	4	5
g	SMEs are characterised by information asymmetry	1	2	3	4	5
h	Most SMEs are not completely honest with their financial records and future business plans.	1	2	3	4	5
i	It is not easy to verify financial information for SMEs, and consequently we limit lending to the SME sector	1	2	3	4	5
j	SMEs are not properly managed	1	2	3	4	5

**END - Thank you for taking the time to complete this questionnaire.**

If you would like to receive a report on the findings, please e-mail the researcher, as it is on request.

**Ashley Mutezo** [muteza@unisa.ac.za](mailto:muteza@unisa.ac.za)

Resp.

no.

--	--	--

## APPENDIX B: SME Questionnaire

### Small and Medium Enterprise Financing and Credit Rationing: The role of banks in South Africa.

Dear SME owner/manager

Thank you for your willingness to participate in this survey. The purpose of the survey is to determine the factors that influence the availability of bank credit to small and medium enterprises (SMEs) in South Africa. The survey should not take more than 30 minutes to complete. This is an anonymous and confidential survey. You cannot be identified and the answers you provide will be used for academic research purposes only.

**Please answer all questions by marking the appropriate selected blank block with an "X". There are no right and wrong answers**

#### SECTION A: DEMOGRAPHIC CHARACTERISTICS

Q1. Please indicate your gender:

Male	1	
Female	2	

Q2. Please indicate your age group:

Below 30 years	1	
30–39	2	
40–49	3	
50–59	4	
60 years and above	5	

Q3. Please indicate your level of education:

None	1	
Standard 8/Grade 10	2	
Standard 9/Grade11	3	
Standard 10/Grade 12 (Matric)	4	
Diploma/certificate (vocational training)	5	
Professional (e.g. CA, CIMA, CIS)	6	
University degree	7	
Post graduate degree	8	

Q4. How did you come to own your SME business?

Inherited from family	1	
Formed the business (started from scratch)	2	
Bought the business	3	
Other, specify	4	

Q5. How long has your business been in operation?

At most a year	1	
2 - 3 years	2	
4 - 5 years	3	
6 - 10 years	4	
More than 10 years	5	

Q6. Which economic sector do you operate in?

Agriculture, forestry and fishing	1	
Mining and quarrying	2	
Manufacturing	3	
Construction	4	
Electricity, gas and water	5	
Transport, storage and communications	6	
Wholesale, retail trade, hotels and restaurants	7	
Finance, insurance, real estate and business services	8	

Q7. Please indicate the number of employees in your business including yourself.....

Q8. What is the legal status of your business?

Sole proprietor	1	
Private company (Pty)	2	
Close corporation	3	
Franchise	4	
Non-profit organisation (NPO)	5	

**SECTION B: FINANCIAL INFORMATION**

Q9. Which of the following banks do you do business with? (Choose all that is applicable)

ABSA	1	
FNB	2	
Nedbank	3	
Standard Bank South Africa	4	
Development banks e.g. Land Bank	5	
Investment banks e.g. Investec	6	
Savings banks e.g. Post Office	7	
Micro Finance Institutions	8	
Other (Please specify)	9	

Q10. Of the banks listed above, which one is the **main** bank for your business?  
 .....

Q11. How long have you been banking with your **main** bank?

At most a year	1	
2-3 years	2	
4-5 years	3	
6-10 years	4	
Over 10 years	5	

- Q12. Which of the following sources of finance did you use to finance your business activities?  
(Mark all applicable)

a	Personal savings	1	
b	Loans from family/friends	2	
c	Bank finance (overdraft, credit cards, personal loans)	3	
d	Microfinance (Loan sharks)	4	
e	Leasing arrangement or hire purchase (e.g. vehicle finance)	5	
f	Factoring (discounting of debts)	6	
g	Trade credit – purchase of goods or services from another business without making immediate cash payment.	7	
h	Government guarantee scheme (e.g. Khula)	8	
i	Equity (issue of new shares, venture capital and business angels)	9	
j	Retained earnings (Internal funds from savings or sale of assets)	10	

### SECTION C: ACCESS TO FINANCE

- Q13. Have you applied for a bank loan in the last three years?

Yes	1	
No	2	

If your answer to Q13 is **NO**, please proceed to **Q21**

- Q14. If your answer to Q13 above is **YES** were any of the loans approved?

Yes	1	
No	2	

- Q15. How many bank loans have you received in the last three years?

One	1	
Two	2	
Three	3	
More than three	4	

- Q16. If you were offered a loan by the bank, which of the following loan duration would you have preferred to pay it back? (**Choose one only**).

		0–3 mths	4–6 mths	7–12 mths	13–18 mths	19–24 mths	> 24 mths
a	Short-term loans (up to 12 months)						
b	Medium-term loans (1-5 years)						
c	Long-term loans e.g. mortgages (over 5 years)						
d	Overdraft						
e	Credit card						

Q17. Which of the following types of loans does your firm have with the main bank? (**Mark all applicable**)

Short-term loans (up to 12 months)	1	
Medium-term loans (1-5 years)	2	
Long-term loans e.g. mortgages (over 5 years)	3	
Bank overdraft	4	
Credit card	5	
None	6	

Q18. To what extent did you use the following types of collateral to secure your bank loans?

		Not to an extent at all	To a little extent	To some extent	To a large extent	To a very large extent
a	Bond over moveable assets (machinery, equipment)					
b	Accounts receivable (e.g. government contract)					
c	Inventories (stock)					

Q19. From the date of application, how many days did it take the bank to approve the following loans?

		1 day	2-3 days	4-7 days	More than a week
a	Short-term (up to 12 months)	1	2	3	4
b	Medium term (1-5 years)	1	2	3	4
c	Long-term (over 5 years)	1	2	3	4

Q20. If your loan application was **rejected**, to what extent do you think the following aspects led to the rejection of your application by the bank.

		Not to an extent at all	To a little extent	To some extent	To a large extent	To a very large extent
a	Lack of acceptable collateral	1	2	3	4	5
b	Lack of 10% contribution (deposit) towards the project	1	2	3	4	5
c	Inadequate credit history of the firm	1	2	3	4	5
d	Incompleteness of the loan application	1	2	3	4	5
e	Lack of comprehensive business plan	1	2	3	4	5
f	Poor credit record of applicant(s)	1	2	3	4	5
g	Inability to repay the loan	1	2	3	4	5
h	No relationship with the bank	1	2	3	4	5
i	Project evaluated by bank as too risky	1	2	3	4	5
j	Non-compliance with the National Credit Act (NCA)	1	2	3	4	5

Q21. If your firm **does not currently have** a loan, what is the reason?

Our firm did not apply for a loan	1	
Our application was turned down	2	
Our application for the loan is still pending	3	

Q22. If your firm **did not apply** for a loan, to what extent were the following statements reasons for not applying for a bank loan?

		Not to an extent at all	To a little extent	To some extent	To a large extent	To a very large extent
a	Application procedures for bank loans are too burdensome	1	2	3	4	5
b	Collateral requirements for bank loans are too strict	1	2	3	4	5
c	The interest rates charged by the banks are too high	1	2	3	4	5
d	It is necessary to make informal payments (bribes) to get bank loans	1	2	3	4	5
e	We were afraid that our loan application would be rejected	1	2	3	4	5
f	We were discouraged because we could not meet the bank requirements	1	2	3	4	5

Q23. Please indicate the estimated value of the following aspects for your firm in the last financial Year (where applicable).

		Less than R50 000	R50000 - R100 000	R101000 - R300 000	R301000 - R500 000	R501000 - R1000 000	Above R1 000 000
a	Fixed assets (buildings and machinery)	1	2	3	4	5	6
b	Total current assets (cash and debtors)	1	2	3	4	5	6
c	Total short-term loans (up to 12 months) if applicable	1	2	3	4	5	6
d	Long-term debt (more than 5 years e.g. mortgage and machinery)	1	2	3	4	5	6
e	Debt (total bank loans)	1	2	3	4	5	6
f	Value of equity (own contribution, friends and family, venture capital, business angels and shares sold)	1	2	3	4	5	6
g	Income for your business in the last financial year	1	2	3	4	5	6
h	Total market value of the assets (fixed, investments and cash)	1	2	3	4	5	6

Q24. To what extent does your firm use the following banking products and services?

		Not to an extent at all	To a little extent	To some extent	To a large extent	To a very large extent
a	Business cheque account	1	2	3	4	5
b	Consultation/advice in financial planning	1	2	3	4	5
c	Loan account	1	2	3	4	5
d	Factoring – purchase of overdue accounts	1	2	3	4	5
e	Leasing (hire purchase)	1	2	3	4	5
f	Foreign exchange (buying and selling foreign currency)	1	2	3	4	5
g	Supplier payments (trade credit)	1	2	3	4	5
h	Collection of receivables	1	2	3	4	5
l	Insurance products (e.g. policies)	1	2	3	4	5

Q25. In your opinion, indicate the level of the willingness of banks to grant credit to SMEs by sector over the last 5 years:

		Increased	Stayed the same	Decreased	Don't know
a	Agriculture, forestry and fishing	1	2	3	4
b	Mining and quarrying	1	2	3	4
c	Manufacturing	1	2	3	4
d	Construction	1	2	3	4
e	Electricity, gas and water	1	2	3	4
f	Transport, storage and communications	1	2	3	4
g	Wholesale, retail trade, hotels and restaurants	1	2	3	4
h	Finance, insurance, real estate and business services	1	2	3	4

Q26. To what extent does your firm use the following e-banking transactional methods?

		Not to an extent at all	To a little extent	To some extent	To a large extent	To a very large extent
a	Electronic Funds transfer (EFT)	1	2	3	4	5
b	Cell phone banking	1	2	3	4	5
c	Internet banking (accessing bank products via the internet)	1	2	3	4	5
d	Transfer of funds without a bank account (e.g. E-wallet)	1	2	3	4	5



Q27. Indicate your level of satisfaction with each of the following aspects of the loan application process?

		Not satisfied at all	Slightly satisfied	Moderately satisfied	Very satisfied	Extremely satisfied
a	The loan amount granted by the bank relative to the amount we requested	1	2	3	4	5
b	The time taken to process the application	1	2	3	4	5
c	The interest rates (the cost of the loan)	1	2	3	4	5
d	The bank charges (administrative costs)	1	2	3	4	5
e	The personal guarantees required by the bank	1	2	3	4	5
f	The government guarantees	1	2	3	4	5
g	The collateral requirements	1	2	3	4	5
h	The overall loan application process	1	2	3	4	5
i	The simplicity of the application form	1	2	3	4	5

Q28. To what extent do the following factors limit you from borrowing from the banks?

		Not to an extent at all	To a little extent	To some extent	To a large extent	To a very large extent
a	High interest rates charged reduce our profits	1	2	3	4	5
b	High bank charges (costs for depositing and withdrawing our money are too high)	1	2	3	4	5
c	Lack of collateral	1	2	3	4	5
d	Distance to the bank (location of firm from the bank)	1	2	3	4	5
e	Poor credit record (blacklisted by the credit bureau)	1	2	3	4	5
f	Fear that loan application might be rejected by bank	1	2	3	4	5
g	Lack of a viable business plan	1	2	3	4	5
h	Too many documents requested by the banks	1	2	3	4	5
i	Over-indebtedness – (inability to repay the loan)	1	2	3	4	5
j	Lack of trust of banks with our money	1	2	3	4	5
k	Banks do not understand the needs of small businesses	1	2	3	4	5
l	Fear of getting into debt	1	2	3	4	5
m	Non-compliance with the National Credit Act (NCA)	1	2	3	4	5

Q29. Any other comment.....  
 .....  
 .....

**Thank you for taking part in this survey.**

If you would like to receive a report on the findings, please e-mail the researcher, as it is on request.

**Ashley Mutezo** [muteza@unisa.ac.za](mailto:muteza@unisa.ac.za)

## APPENDIX C: Items dropped during factor analysis

The following table gives the items removed from dimension to increase reliability

Dimension	Items removed from dimension	Old reliability value	Current reliability value
Obstacles in SMEs lending	Small size of the SME sector	0.405	0.708
	Weakness in the judicial system		
	Interest rate ceilings imposed by regulation		
	Bank learning to do business with SMEs		
	Limited geographic presence of the bank within the country		
	Lack of expertise in dealing with SME financing		
	Informality of SMEs (not formally registered)		
	Inability to prosecute owner in case of default		
Response to excess demand	Increase interest rate to clear the excess demand	0.552	0.727
Lending technology	Relationship-based lending	0.697	0.730
Measures of creditworthiness	Regular visits to the SME premises	0.453	0.757
	Regular reporting from the SME		
Transactional costs	Lack of long-term relationships established with SMEs	0.546	0.790
Objection on bank firm relationship	Use the information to refine the loan contract terms	0.670	0.752
	Make a decision on the loan rate		
	Make a decision on collateral requirements		
Bank firm relationship	Distance of the firm from the bank	0.512	0.702
	Pre-existing relationship		
Collateral	Vehicle asset	0.361	0.671
	Someone to guarantee the loan in case of repayment default		
Risk management	Lower risk borrowers are willing to pledge more collateral with low interest rate.	0.209	0.611
	Pledging more collateral will not increase the supply of bank credit to SMEs.		
	Banks do not lend to SMEs without a banking history with them.		
	Pledging more collateral will not increase the supply of bank credit to SMEs.		
	Banks do not lend to SMEs without a banking history with them.		
Factors hindering approval of SME lending application	Poor credit record of applicant(s)	0.377	0.726
	Project evaluated by the bank as too risky		
	Lack of financial literacy and business skills		
	Poor financial records of small businesses		
	Poor cash flow projections		

Innovative strategies	Cell phone banking (accessing bank products on mobile phones)	0.278	0.622
	Unsecured credit (not backed by collateral)		
	Qualitative Credit Assessment (QCA) questions to determine probability of default		
	Internet or on-line banking (accessing bank products via the internet)		
Risky nature of SMEs	Most SMES businesses are not viable	0.579	0.706

## **APPENDIX D**      Informed consent letter for banks

Contact person

Bank

Small Business Services

E-mail address:

Dear Sir/ Madam

I, Mrs Ashley Mutezo am doing research with Prof Jackie Young in the Department of Finance, Risk Management & Banking towards a D.Com degree at the University of South Africa. We are inviting you to participate in a study entitled: “**Small and Medium Enterprise Financing and Credit Rationing: The role of banks in South Africa.**”

The aim of the study is to investigate the significance of credit rationing in SME financing by commercial banks in a South African context. Also the study attempts to investigate the process of SME lending and importance of relationship lending and its impact on the access to bank finance by SMEs.

The study will entail a survey of commercial banks located in the Gauteng province of South Africa. The survey will comprise of a sample of commercial banks of South Africa who have a banking relationship with SMEs. A questionnaire will be sent out to selected bank officials who are involved one way or another with the SME loan application process and the management of the risks involved.

Being in this study is voluntary and you are under no obligation to consent to participation. You are free to withdraw (opt-out) at any time or stage during the completion of the questionnaire without giving a reason. The survey should not take more than 30 minutes to complete. All data obtained from you will be kept confidential and will only be reported in an aggregate format (by reporting only combined results and never reporting individual ones). All questionnaires will be concealed, and no one other than the primary investigator and promoter will have access to them.

There are no direct benefits to participants in this study. However, we hope that the information obtained from this study may be used to simplify the bank lending process to SMEs and improve SME access to bank finance. The results from this study will be presented in a thesis and possibly articles at a later stage. At no time, however, will your organisation's name be used or any identifying information revealed. If you wish to receive a copy of the results from this study, you may contact one of the researchers at the contact details given below.

Electronic copies of your answers will be stored by the researcher for a period of five years on a password protected computer. Future use of the stored data will be subject to further Research Ethics Review and approval if applicable. After the 5 year period all information will be permanently deleted.

If you require any information about this study, or would like to speak to one of the researchers, please call Mrs Ashley Mutezo at 012 429 4595 or e-mail [muteza@unisa.ac.za](mailto:muteza@unisa.ac.za) or Professor Jackie Young on 012 429 3010 or e-mail [youngj@unisa.ac.za](mailto:youngj@unisa.ac.za) at the University of South Africa.

If you have any other questions regarding your rights as a participant in this research, you may also contact the College Research Ethics Review Committee of the University of South Africa via email at [uysm@unisa.ac.za](mailto:uysm@unisa.ac.za)

Thank you for taking the time to read this information sheet and for choosing to participate in this study. Please note that by completing the questionnaire you agree that you understand the information shared with you and that you voluntarily participate.

Yours Sincerely,

.....

Ashley Mutezo (Mrs)

## **APPENDIX E: Informed consent for the SME owner/manager**

Dear SME owner/manager

I, Mrs Ashley Mutezo am doing research with Prof Jackie Young, in the Department of Finance, Risk Management & Banking towards a D.Com Degree at the University of South Africa. We are inviting you to participate in a study entitled: **“Small and Medium Enterprise Financing and Credit Rationing: The role of banks in South Africa.”**

The aim of the survey is to investigate the factors that influence the availability of bank credit to small and medium enterprises (SMEs) in South Africa. Despite the efficiency of the banking sector in South Africa, SMEs still experience problems in accessing bank credit. The study therefore involves a survey questionnaire which will focus on the problems and challenges that SMEs located in the Gauteng province of South Africa experience.

Being in this study is voluntary and you are under no obligation to consent to participation. You are free to withdraw (opt-out) at any time or stage during the completion of the questionnaire without giving a reason. The survey should not take more than 30 minutes to complete. All data obtained from you will be kept confidential and will only be reported in an aggregate format (by reporting only combined results and never reporting individual ones). All questionnaires will be concealed, and no one other than the primary investigator and promoter will have access to them.

There are no direct benefits to participants in this study. However, we hope that the information obtained from this study may be used to simplify the bank lending process to SMEs and improve SME access to bank finance. The results from this study will be presented in a thesis and possibly articles at a later stage. At no time, however, will your organisation's name be used or any identifying information revealed. If you wish to receive a copy of the results from this study, you may contact one of the researchers at the contact details given below.

Electronic copies of your answers will be stored by the researcher for a period of five years 1) on a password protected computer. Future use of the stored data will be subject to further Research Ethics Review and approval if applicable. After the 5 year period all information will be permanently deleted.

If you require any information about this study, or would like to speak to one of the researchers, please call Mrs Ashley Mutezo at 012 429 4595 or e-mail [muteza@unisa.ac.za](mailto:muteza@unisa.ac.za) or Professor Jackie Young on 012 429 3010 or e-mail [youngj@unisa.ac.za](mailto:youngj@unisa.ac.za) at the University of South Africa.

If you have any other questions regarding your rights as a participant in this research, you may also contact the College Research Ethics Review Committee of the University of South Africa via email at [uysm@unisa.ac.za](mailto:uysm@unisa.ac.za)

Thank you for taking the time to read this information sheet and for choosing to participate in this study. Please note that by completing the questionnaire you agree that you understand the information shared with you and that you voluntarily participate.

Yours Sincerely,

.....

Ashley Mutezo (Mrs)

COLLEGE OF ECONOMIC AND MANAGEMENT SCIENCES  
RESEARCH ETHICS REVIEW COMMITTEE

18 June 2014

Dear Mrs Mutezo,

**Decision: Ethics Approval**

Ref #: 2014\_CRERC\_020 (FA)  
Name of applicant: Mrs Ashley T Mutezo  
Student #: 31629148  
Supervisor: Prof Jackie Young  
Staff #: 90074904

**Principal applicant:** Mrs Ashley Teedzwi Mutezo, muteza@unisa.ac.za, 012-429 4595

**Supervisor:** Prof Jackie Young, youngj@unisa.ac.za, 012-429 3010

**Proposal:** Credit rationing and risk management for SMEs – the case of leading South African commercial banks.

**Qualification:** D.Com Business Management

Thank you for the application for research ethics clearance submitted to the College of Economic and Management Sciences Research Ethics Review Committee for the above mentioned research. Final approval is granted for the duration of the project.

The application [was reviewed in compliance with the Unisa Policy on Research Ethics by a sub-committee of the CRERC on 17 June 2014. The decision will be tabled at the next CRERC meeting on 23 June 2014 for notification.

The proposed research may now commence with the proviso that:

- 1) The researcher/s will ensure that the research project adheres to the values and principles expressed in the UNISA Policy on Research Ethics.
- 2) Any adverse circumstance arising in the undertaking of the research project that is relevant to the ethicality of the study, as well as changes in the methodology, should be communicated in writing to the College of Economic and Management Sciences





Ethics Review Committee. An amended application could be requested if there are substantial changes from the existing proposal, especially if those changes affect any of the study-related risks for the research participants.

- 3) The researcher will ensure that the research project adheres to any applicable national legislation, professional codes of conduct, institutional guidelines and scientific standards relevant to the specific field of study.

**Note:**

The reference number [top right corner of this communiqué] should be clearly indicated on all forms of communication [e.g. Webmail, E-mail messages, Letters] with the intended research participants, as well as with the CRERC.

Kind regards,



Prof JS Wessels

Deputy Chairperson of the CRERC, CEMS, UNISA

012-429 6099/ wessejs@unisa.ac.za



Prof Valiant Clapper

Executive Dean: CEMS

