

3 *Risk analysis strategies in the water utility sector: an inventory*
4 *of applications for better and more credible decision-making*

5
6 MacGillivray, B.H., Hamilton, P.D., Strutt, J.E. and Pollard, S.J.T. *

7
8 *School of Water Sciences, Cranfield University, Cranfield, Bedfordshire, MK43 0AL,*
9 *UK.*

10
11 * *Corresponding author*

12
13 **ABSTRACT**

14
15 Financial pressures, regulatory reform and sectoral restructuring are requiring
16 water utilities to move from technically inclined, risk-averse management approaches
17 toward more commercial, business-oriented practices. Risk analysis strategies and
18 techniques traditionally applied to public health protection are now seeing broader
19 application for asset management, assessing competition risks and potential threats to
20 the security of supplies. Water utility managers have to consider these risks alongside
21 one another and employ a range of techniques and devise business plans that prioritise
22 resources on the basis of risk. We present a comprehensive review of risk analysis
23 and management strategies for application in the water utility sector at the strategic,
24 programme, and operational levels of decision making.

25
26 **Keywords:** decision making, risk analysis, utilities, water safety plans.

1 INTRODUCTION

2

3 A. Background

4

5 Providing wholesome, affordable and safe drinking water that has the trust of
6 customers are the overarching goals of the water utility sector. The sector has publicly
7 stated⁸ that achieving this requires, at a minimum, that water is safe in microbiological
8 and chemical terms; that it is acceptable to consumers in terms of taste, odour and
9 appearance; and that the supply is reliable in terms of quality and quantity. Delivering
10 these objectives in the context of an increasingly demanding consumer and regulatory
11 environment, under constraints imposed by ageing infrastructure and the trend
12 towards financial self-sufficiency is challenging. Many within the industry, spurred
13 on by developments in international regulation and guidance, are now promoting a
14 business-wide approach to risk management as a means to ease and exploit this
15 transition (*e.g.* Lifton and Smeaton⁸²). In practice, water quality managers and
16 internal audit functions within the sector are working more closely to address issues of
17 business risk and many of the larger international water companies now have ‘group
18 risk managers’ in place to manage business and consumer risks within a single
19 portfolio. Implementation of this business-wide approach to risk management is not
20 straightforward, however - it requires:¹²¹

21

- 22 (i) integrated frameworks for the management of internal risks (*e.g.* from
23 ageing infrastructure) and external risks (*e.g.* from ‘competitor’ actions) to
24 the utility;
- 25 (ii) the support of Board level, executive management and operational staff as
26 well as that of external stakeholders; and

1 (iii) the effective communication of risk and engagement within decision-
2 making processes both within companies and with external stakeholders.

3

4 Furthermore, as illustrated in this review, there are potential tensions between
5 managing the risks of a commercial water business and the overarching public health
6 goal of the water industry, stated above. Critically in this regard, the transition to an
7 explicit risk management philosophy within the water utility sector is now reflected in
8 recent revisions to the World Health Organisation's (WHO) Guidelines for Drinking
9 Water Quality.^{167,168,45} This is placing an emphasis on the development and
10 implementation of 'water safety plans' for water quality management and, within
11 these, the application of risk frameworks and risk tools such as the 'hazard analysis
12 and critical control points' (HACCP)^{34,64} approach as a basis for prioritising risk
13 management measures within the water supply chain from catchment to tap. The risk
14 management approach is becoming increasingly embedded within utilities and with it
15 a maturing view of risk analysis, shifting from that of a one-off technique to 'placate'
16 regulators towards that of a practical methodology to facilitate process control,
17 optimisation and corporate decision-making within a cost-effective framework.
18 Despite a growing consensus, there remain significant barriers to the implementation
19 of risk management within utilities. These can be categorised as business-related, the
20 challenge of integrating risk management within organisational cultures and decision-
21 making processes (*e.g.* Pollard *et al.*¹²¹); and technical, relating to the selection and
22 application of risk analysis tools. One of the key difficulties all organisations face in
23 implementing risk management is managing the interfaces between high level
24 corporate objectives, business plans and operational reality. Here then, we critically
25 review the risk analysis strategies and tools and techniques available for risk analysis
26 within the sector, with particular emphasis on decision-making at the corporate

1 (strategic), business (programme level) and operational levels in water utilities.
2 Necessarily the discussion requires excursions into the management and technical
3 environmental literature. However, we view the juxtaposition of these aspects of risk
4 management as central to providing a well-round examination of the prior art in the
5 current context of its application within the sector.

6
7

8 **B. Risk analysis and decision-making**

9 Before entering a discussion on risk analysis, we must be clear in our
10 terminology. In simple terms, risk is widely accepted to consist of a combination
11 of probabilities and consequences. However, further clarity is required. Adapting
12 Hrudey's⁶⁸ elaboration, we consider the notion of risk to be a prediction or
13 expectation that involves:

- 14 • an agent with the potential to cause either harm and/or benefit (*e.g.* a
15 chemical contaminant, or an investment opportunity);
- 16 • uncertainty of occurrence and outcomes (expressed by the probability or
17 likelihood of occurrence);
- 18 • consequences (the possible outcomes);
- 19 • a specified time frame.

20
21 The exploration of these facets provides us with an analysis of risk (note that the
22 authors consider the terms risk assessment and risk analysis to be interchangeable).
23 Risk is inextricably linked to uncertainty. Thus uncertainty analysis plays a
24 prominent role in many risk analysis strategies. Finally, and in a distinct business
25 context, we consider risk management as the sum of the constituent sets of socio-
26 technical decisions and actions taken by staff to optimise their organisation's exposure
27 to risk.

1 Risk analysis plays a role alongside other decision tools for risk management.¹²¹
2 Detailed risk analysis is not a prerequisite for effective risk management. In many
3 industries there are accepted standards of performance and codes of practice (*e.g.*
4 engineering standards; accepted best practice; Figure 1) that, if adhered to, provide
5 high degrees of control. These are applied in familiar and well-characterised
6 situations where uncertainties and system vulnerabilities are well understood.
7 However, complex, uncertain and novel systems, that deviate from routine operation,
8 may require risk analysis, so as to better understand what drives the risk from or to the
9 plant, process or operation, thereby allowing management measures for the reduction
10 of unacceptable risks to be targeted for greatest effect.¹²¹ This principle extends
11 beyond the operation of technical systems to embrace all aspects of managing a
12 business. This said, risk analysis is, in many respects, a practitioner-driven discipline.
13 Its application within water utilities has its roots firmly in the protection of public
14 health from pathogens afforded by the multiple barrier approach to raw water
15 treatment. Whilst the extension of risk analysis to asset management, water supply
16 security and catchment (watershed) management is clearly evident, these applications
17 and the use of risk-based techniques for optimising treatment plant performance, on-
18 site energy use, maintenance programmes and compliance monitoring regimes can
19 inadvertently but easily detract from and confuse the principal purpose of the water
20 supply industry – to provide wholesome, affordable and safe drinking water that has
21 the trust of customers. In all these applications this goal must remain paramount.

22

23

24 **C. The risk hierarchy**

25

1 The organisational hierarchy that exists even within ‘flat’ organisations requires
2 that risks are actively managed at the strategic, programme and operational levels of
3 an organisation (Figure 2). Typically, there are split accountabilities for these risks
4 such that the chief financial officer / financial director and Board have overall
5 responsibility, supported by an internal audit or control function for the management
6 of strategic risks; executive and senior management address programme level risks
7 (*e.g.* asset management, maintenance planning); and operational (*e.g.* site) managers
8 bear responsibility for operational risks (*e.g.* treatment plant performance).¹²¹ A range
9 of strategies exist for assessing and managing these risks in a business context. The
10 focus in this review is sector-specific, addressing ‘process’ risk analysis (*i.e.* risks at
11 the operational and programme level), but in establishing a business-wide context for
12 this activity we also draw upon the experiences of organisations assessing risk at the
13 strategic level.

14
15

16 **2. STRATEGIC RISK ANALYSIS**

17

18 Within an overarching context of public health protection and the maintenance
19 of process reliability, utility managers are increasingly concerned with managing the
20 risks inherent to corporate level decision-making. Critical issues include decisions on
21 outsourcing asset maintenance, billing and monitoring, the management of change,
22 staff retention, the long-term viability of investment decisions, and the management of
23 external interfaces with regulators and ‘competing’ utilities. Risk analysis tools are
24 available to inform decisions on these issues (Table 1).

25

26 **A. Regulatory risk**

27

1 Throughout the 20th Century, the central role of water quality to the protection
2 and preservation of public health encouraged governments to manage utilities within
3 the public sector.¹³⁸ Regulation was historically self-imposed and limited in scope,
4 and, by extension, posed relatively low risk to municipalities and utilities (in terms of
5 both the likelihood of non-compliance and the associated penalties). In contrast, more
6 recent (since the 1980s) regulatory pressures and drives to impose market discipline
7 on the sector, whether directly (privatisation) or by proxy (*e.g.* corporitisation or
8 required self-sufficiency), have externalised and broadened the role of regulatory
9 scrutiny and intervention. Here our discussion is largely restricted to economic
10 regulation.

11 A concept of regulatory risk is difficult to grasp. Parker^{114,115} contends that it
12 arises from the nature of the regulatory rules and practices, with rules determining the
13 extent to which interventions are discretionary, and practices relating to the
14 interpretation the regulators and others (particularly government) place on the rules.
15 Kilpatrick and Lapsey⁷⁵ consider regulatory risk as the uncertain impact of regulatory
16 decisions on regulated companies. Regulatory risk may best be considered as a
17 combination of the above interpretations, encompassing both the uncertainty of the
18 decision-making process and of its impact on utilities.

19 The core issues of regulatory risk are: regulatory independence; regulatory
20 discretion; transparency and accountability. Independence is critical to minimising
21 the risk of political interference in a regulatory regime. For example, in England and
22 Wales, the economic regulator (the Office of Water Services; Ofwat), acting in the
23 public interest, is vested with a high degree of autonomy from central government,
24 ensuring that the regulatory process is not subject to direct political interference. In
25 contrast, in South Australia (SA), the state government directly controls the tariff
26 setting process, and as the dividend from SA Water is a significant contributor to the

1 state budget, there is the danger that political considerations, as well as commercial
2 ones, might be perceived to influence regulatory pricing.⁷

3 Regulatory discretion refers to the freedom afforded to regulators to interpret
4 the importance of set duties and objectives and to determine how best to accomplish
5 them.^{114,75} In the UK, Ofwat's Director General is free to identify and change the
6 importance attached to set objectives within the regulatory system, within broadly
7 defined constraints.¹¹⁴ Arguably, the greater the discretion afforded to the regulator,
8 the greater the uncertainty related to future regulatory decisions. Ofwat's regulatory
9 practices are characterised by high levels of transparency and accountability. In
10 practice, utilities are fully engaged in regulatory decision-making, with avenues for
11 consultation and appeal established should companies wish to challenge the outcome.
12 Similarly, the New Jersey Board of Public Utilities, which regulates all investor-
13 owned utilities in the State, publishes reports on its activities and is transparent and
14 accountable in its decisions and processes.⁷ These arrangements compare to the
15 German system. Water and sewerage in Germany is the responsibility of the
16 municipalities and the municipalities regulate and manage the water supply based on
17 European, national, state and municipal legislation. Though many are satisfied with
18 these relationships, there has been criticism in a recent report,⁷ where regulatory
19 decisions were viewed as being taken in a closed fashion with little clear
20 accountability.

21 The nature of a regulatory system (*i.e.* its objectives and the systems in place for
22 their achievement) represents a core strategic risk for water utilities. For example, in
23 many developing countries, regulatory scrutiny is largely confined to ensuring a safe,
24 secure water supply,⁷ which, whilst introducing inherent operational risks, does not
25 invoke strategic uncertainty. In contrast, main goal of Ofwat is to facilitate

1 competition within the sector, an objective that introduces utilities to a range of
2 hitherto unknown risks.

3 Quantitative treatments of regulatory risk within the literature are restricted to
4 *ex-post* analyses of the relationship between utility share price volatility and the
5 regulatory process. Buckland and Fraser¹⁹ modelled variations in the systemic
6 (market) risk, using a variable β (which measures the variability in returns of a stock
7 relative to the variability of the broader market), of UK water utilities over time,
8 examining the extent to which observed variations were associated with the regulatory
9 process. A key finding was the surge in the market's assessment of the systemic risk
10 to the industry accompanying the 'surprise' result of the 1992 general election. The
11 authors' analysis illustrates the influence of politics in even the most independent of
12 regulatory systems. Similarly, Morana and Sawkins⁹⁸ modelled the London stock
13 market's response to the 1994 'periodic review' of water price setting in the England
14 and Wales utility sector, finding a significant reduction in share price volatility, which
15 they postulated to be a reflection of shareholder confidence in the credibility and
16 sustainability of the settlement.

17 Ideally, for the active management of regulatory risk, analyses should extend to
18 *ex-ante* treatments of risk. This is of particular relevance to the modern water utility
19 sector, where widespread structural reforms are requiring utilities to operate under
20 rapidly evolving regulatory systems – creating unprecedented uncertainty. In such a
21 market, there has been no historical evolution and the participants, including the
22 regulatory institutions, have a limited understanding of how it will operate in the short
23 term and evolve in the future.⁷⁸ In such situations, analytical models may offer value
24 in alerting utilities to unintended consequences of their actions that may trigger the
25 regulator into reaction.⁷⁸ Larsen and Bunn⁷⁸ argue that system dynamics, which
26 incorporates systems thinking into simulation modelling, is conducive to the dynamic,

1 uncertain and subjective nature of assumptions inherent to strategic analysis. To
2 illustrate, Bunn *et al.*²⁰ developed a system dynamics model to simulate regulatory
3 problems in the restructured UK gas and electricity markets. Following problem
4 definition and hypothesis formulation, the authors constructed a simulation model
5 describing the main feedbacks involved in the exercise of ‘latent’ market power.
6 Their analysis explored the relationship between corporate strategies designed to
7 exercise this power and the risk of regulatory scrutiny. The authors concluded that
8 market mechanisms were open to exploitation. Such analysis, and assessments of
9 system sensitivity, could provide utility managers with *a priori* insights into
10 opportunities for exploiting market ‘imperfections’, thus aiding the development of
11 corporate strategies.

12

13

14 **B. Competition risks**

15

16 *Comparative competition*

17

18 On account of the water industry’s inherent monopolistic nature, many
19 governments and their regulators have sought to expand the role of sectoral
20 competition. None more prominently perhaps than in the UK, where the concept of
21 comparative competition underpins the regulatory regime.^{137,135} The theory of
22 comparative, or ‘yardstick competition’ may be traced to the work of Shleifer,¹⁴³ who
23 proposed a regime in which the price (or financial rewards) received by a regulated
24 firm depends not on its costs (as in traditional ‘cost-of-service’ or ‘rate-of-return’
25 regulation), but rather on the costs of ‘identical’ firms operating within the same
26 sector. Shleifer reasoned that by breaking the dependence between the price a firm

1 received and its own costs, and ensuring that the rewards for a given firm depended
2 on its standing *vis-à-vis* a ‘shadow firm’ (a weighted average of other firms operating
3 within the sector – an idealised benchmark), each firm would be forced to ‘compete’
4 with its shadow, providing incentives for cost efficiency (widely perceived as lacking
5 from rate of return regulation). In practice, the inherent risks of this ‘competition by
6 proxy’ pale in comparison to those found in fully liberalised markets because market
7 share is not directly threatened.

8 Techniques for evaluating the ‘explicit’ risks posed by competitors have been
9 well developed in the business and economic literature. A notable example is
10 competitor analysis, with its potential to reduce the uncertainty of the price review
11 process (as price setting is linked to competitor performance). Its application is
12 helped by the tendency for regulatory bodies to disclose company performance data in
13 the interests of transparency. In addition to reducing uncertainty, competitor analysis
14 represents a strategic tool which assists managers in: evaluating competitors’
15 strengths and weaknesses; identifying sources of competitive advantage; and
16 assessing the implications of competitors’ strategies on both the sector and their own
17 utility.^{38,133}

18

19 *Capital market competition*

20

21 As Cowan²⁷ contends, competition in the capital market can be thought of as a
22 private-sector version of yardstick regulation, in that it derives from the ability of
23 investors to make comparisons between different companies in the same sector.
24 Littlechild,⁸⁵ in his report to the UK Department of the Environment on the prospects
25 for water privatisation, emphasised that this would be an important incentive
26 mechanism for utilities, as inefficient firms would be reflected in their share price and

1 be vulnerable to take-over, in addition to facing higher costs of capital. Although
2 Ofwat's restrictions on mergers within the UK water sector, in the interests of
3 maintaining sufficient comparators, act as a constraint on capital market
4 competition,²⁷ the growing internationalisation of the industry increases the risk of
5 'external' mergers, whilst firms looking to diversify remain a threat to existing
6 utilities.

7 Furthermore, the quality and quantity of comparative information available
8 under the 'yardstick' system assists predators in identifying and assessing potential
9 take-over targets.¹³⁶ Singh and Harianto,¹⁴⁵ in reviewing the acquisition literature,
10 surmised that profitability, size, leverage, and dividends were negatively correlated
11 with the risk of being acquired. In contrast, profitability and liquidity were positively
12 correlated with the probability of a firm acquiring, with leverage and dividends
13 negatively so. In light of this information, the dynamic risk of take-over can be
14 tracked both in real-time (*e.g.* with respect to the transfer of, for example, more than
15 5% of firm stocks to a potential acquirer and, in the US, the filing of 13D statements
16 indicating investor intent) and pro-actively (by 'screening' the external environment
17 for trends and potential hostile bodies). Of further interest to corporate strategists,
18 recent research by Dickerson *et al.*³⁵ suggests that acquisition can be used as a
19 strategy to reduce the risk of take-over. The researchers concluded this strategy
20 allows firms to grow quickly, thus protecting them from subsequent take-over. For
21 utilities considering expansion or diversification strategies, take-over represents not
22 just a threat but also an opportunity.

23

24 *Competition for the market*

25

1 Another means of fostering competition is to encourage the private sector
2 (perhaps along with the incumbent public utility) to bid competitively for a
3 concession, lease, tender, or management contract.²⁷ The two key vehicles for doing
4 so are franchising and, more conservatively, contracting out (not involving the
5 transfer of assets). Numerous variants of these processes are adopted internationally,
6 including: build, operate and transfer (BOT) arrangements; finance, operate and own
7 (concession); and operate and provide working capital (*affermage*). The inherent
8 complexity of many of these arrangements, the generally low equity in the project
9 vehicle,⁵⁵ and the often significant investment obligations required of the sponsor,
10 create a pressing need for comprehensive risk assessment.

11 The project and financial risks associated with public-private partnerships have
12 been reviewed by Grimsey and Lewis.⁵⁵ Using the financing of Stirling Water, a
13 Scottish design-build-operate contractor as an illustrative example, they discuss the
14 complexity of the contractual arrangements within such partnerships and use a
15 quantitative analysis of returns on investment to characterise the robustness of cash
16 flows from each of the senior lenders to this joint public-private venture. From the
17 procurer's perspective, project risks (*e.g.* delays and claims) are valued and
18 incorporated within the NPV calculation, whilst the impact of financial risks (inflation
19 and interest rate changes) are evaluated through sensitivity analysis. From the
20 sponsor's perspective, risk analysis centres on simulating the effect of the underlying
21 variables (*e.g.* operating performance) upon the equity return. Ranasinghe¹²⁸ uses
22 water supply projects in Sri Lanka to outline a methodology based on financial risk
23 analysis that a government or public utility can use to assess the viability of private
24 sector participation in new infrastructure projects. The author links a commercially
25 available simulation package to the financial model to analyse the uncertainty
26 associated with the underlying variables (*e.g.* escalation in cost).

1

2 *Product market competition*

3

4 The traditional approach to introducing direct product market competition into
5 utility services has been to separate the monopolistic component of the industry and
6 regulate it, and to encourage competition in all other areas, *e.g.* the UK model of
7 separating the gas, electricity and railway networks (monopolistic) from the supply of
8 services over the network.²⁷ This so-called ‘vertical disaggregation’, although
9 promoted by the World Bank,¹⁷² has not been widely adopted in the water sector, the
10 implicit assumption being that the industry is naturally monopolistic.^{27,138} The UK
11 has led the way in adopting alternative approaches to facilitate product market
12 competition. This can be traced back to the 1991 Water Industry Act, which
13 introduced the concept of ‘Inset’ appointments, whereby a utility can apply for an
14 appointment to provide water to a ‘large’ customer located within the statutory area of
15 an existing company, usually by seeking a bulk supply from the incumbent.⁶⁵
16 Sawkins¹³⁶ reports that the first Inset appointment was granted in May 1997, when
17 Anglian replaced Essex and Suffolk Water (ESW) as the supplier to Buxted Chickens
18 Ltd. Company licences were altered and a new pipe constructed linking the site with
19 an Anglian water main.

20 In practice, various restrictions, recently eased, have meant that this form of
21 competition has been slow to develop.¹³⁶ Similarly, although the 1992 Competition
22 and Service Act allows for cross-border competition, the costs are prohibitive in the
23 majority of cases. Perhaps the most significant recent development has been the
24 introduction of the 1998 Competition Act, which created the possibility for common
25 carriage agreements, or network sharing, in the water industry. Here, the shared use
26 of an incumbent’s infrastructure by a third party enables the latter to provide services

1 within the incumbent's area. To aid this, Ofwat now requires that all water utilities
2 publish 'Access Codes' that set out their terms and conditions for common carriage,
3 and has published guidance on this procedure.¹¹⁰ Hern⁶⁵ reports that under the Act,
4 utilities risk infringement if they refuse access to any parts of their infrastructure
5 deemed 'essential' without objective justification, or if their access terms are
6 considered unreasonable. Although no successful applications for common carriage
7 have resulted to date, the threat alone acts as a catalyst for performance
8 improvements.

9 The authors were unable to uncover literature quantitatively addressing the risks
10 of product market competition within the water utility sector, a reflection of its
11 nascent development and descriptive nature. It seems appropriate here, however, to
12 introduce an oft-neglected truism: quantitative risk analysis is not a prerequisite of
13 effective risk management. This is apt in addressing the threats introduced by
14 product-market competition, where competitor identification and analysis, in concert
15 with a critical appraisal of self-performance and room for improvement, often provide
16 an appropriate foundation for minimising competitive threats. In contrast, harnessing
17 the opportunities presented by product-market competition requires more detailed
18 analysis, and in the absence of a relevant body of literature, the authors suggest
19 treating what are effectively, at least in the UK model, potential acquisitions of
20 company operations in the manner of strategic investment decisions.

21

22 **C. Business process re-engineering risks**

23

24 Our discussion thus far has focused on the strategic approaches to risk
25 management within the sector. The pressures described are having important impacts
26 on the performance of the water sector. Structural changes to utility markets, an

1 increasingly demanding political and consumer environment, and more stringent
2 regulation are requiring utilities to improve financial and operational efficiencies. As
3 Westerhoff¹⁶⁶ notes, water utilities are responding by rethinking their operations,
4 finding new ways to address problems, and revamping traditional business models –
5 in other words, re-engineering. According to Clemons,²³ major business process re-
6 engineering (BPR) initiatives – which range from the redesign of existing processes
7 for efficiency improvements, to the development of novel processes in support of a
8 new corporate vision – require the commitment of substantial resources and often
9 constitute a lasting legacy. If we define the risk of a project as the deviation in results
10 from the established goals, then there is substantial empirical evidence marking BPR
11 as a high risk endeavour. Many, if not most re-engineering efforts ultimately ‘fail’
12 (see Crowe *et al.*,²⁸ Remenyi and Heafield¹³⁰). Of particular relevance is the work of
13 Dean *et al.*,³¹ whose analysis of change programmes undertaken in the UK water
14 industry suggests that re-engineering efforts, whilst often effective, produce highly
15 variable outcomes. On account of this, project risk analysis should be an integral part
16 of any re-engineering effort.

17 Clemons²³ considers the core determinants of the risk profiles associated with
18 large scale BPR efforts to be: (a) functionality risk – the risk of making inadequate or
19 incorrect changes to systems or processes; and (b) political risk – the risk that the
20 organisation will not complete the project, either because of significant internal
21 resistance to the proposed changes or due to a more gradual loss of will. Clemons
22 promotes scenario planning – a strategic planning tool that embraces uncertainty – as
23 a means for assessing and subsequently managing the risks associated with re-
24 engineering efforts. Rather than determining a single ‘correct’ view of the future with
25 its implicit single response, scenario planning acknowledges the key sources of
26 uncertainty and incorporates these in developing a range of future scenarios and

1 strategic responses for exploration. Clemons argues that its use is suited to the
2 context of re-engineering efforts as it encourages the critical examination of potential
3 futures and strategies, reduces functionality risk and helps ensure the need for change
4 is internally addressed and accepted, thus reducing political risk. Scenario planning
5 has been embraced by the majority of UK water utilities.¹²⁰ A 2001 study¹²⁰ explicitly
6 linked the tool's use with improved financial performance on the part of utilities,
7 although notably the authors suggest that scenario planning may implicitly encourage
8 firms to focus on financial returns at the expense of customer service levels.

9 Recent work by Crowe *et al.*²⁸ has led to the development of a semi-quantitative
10 tool for estimating the 'risk of failure' of companies about to undertake re-engineering
11 efforts. The tool, developed through a survey of BRP-experienced organisations, is
12 based on measures of the core success (*e.g.* egalitarian leadership; collaborative
13 working environment; top management commitment; and change management
14 systems) and failure (middle management fear of losing authority; fear of job loss;
15 scepticism; discomfort of new working environment) factors of implementing change.
16 Raw data is extracted by questionnaire (*e.g.* "do managers usually share vision and
17 information with their subordinates") is used to mine information on the general
18 leadership style), and refined *via* fuzzy mathematics. Crowe *et al.*'s model is intended
19 to provide companies with an estimate of the likelihood of success or failure of
20 proposed efforts prior to committing resources and to improve management's *a priori*
21 insights into the potential outcomes of re-engineering. Similarly, Remenyi and
22 Heafield¹³⁰ outline a methodology for evaluating the key risk issues relating to re-
23 engineering efforts. The methodology centres on a risk matrix (Table 2) that groups a
24 variety of potential BPR risks under the categories of business risk, financial risk,
25 corporate structure, corporate culture, technology and human. Organisations identify,
26 weight and rank what they consider to be the ten factors most pertinent to their

1 proposed re-engineering efforts. The framework represents a succinct method for
2 appraising and comparing the risks associated with BPR strategies. A perceived
3 failure of much of the BPR literature is the limited emphasis placed on the risks
4 introduced by adopting new technologies, an aspect critical to many re-engineering
5 efforts.

6

7 *Technological risk*

8

9 Clark *et al.*²² report that technology adoption is increasingly becoming a
10 concern of strategic planners and policy makers within the water industry. The
11 introduction of novel technology poses risks due to the inherent difficulty of preparing
12 accurate estimates of the costs, performance and system-wide effects of new
13 components and processes; and the long development cycles required for changes in
14 regulations and consumer demands.²⁶ This has led many researchers to advocate the
15 incorporation of risk management techniques for the effective implementation of new
16 technologies (*e.g.* Colmer *et al.*²⁶; Fitzpatrick⁴⁷). This is highly relevant to the water
17 sector, where, as Maxwell⁹¹ notes, the advance of modern technology is illustrated by
18 such trends as the replacement of traditional methods of water treatment with
19 advanced oxidation and other novel physical and mechanical technologies; the broad
20 use of membrane systems to desalinise seawater for human consumption; and the
21 increasingly widespread use of recycling systems and technologies.

22 McGaughey *et al.*⁹² describe a framework for viewing and comparing the risks
23 inherent in the adoption of new technologies, specifically relating to IT. Initially,
24 proposed projects are assessed, through value chain analysis, in terms of their
25 potential positive and negative outcomes – these are then mapped onto a ‘speculative’
26 risk matrix to provide management with an initial screening of alternatives. In later

1 stages of planning, specific threats and opportunities associated with the project are
2 identified and ranked, by likelihood and consequence, for prioritisation purposes.
3 Hartmann and Lakatos⁶² drew on case studies monitoring the pace and quality of
4 technology delivery within two product development programmes and generated an
5 algorithm characterising the risk of each technology problem (Figure 3). The authors
6 suggest that its use can aid in the refinement of technology development and
7 implementation plans following risk identification. Hartmann and Lakatos define
8 technology problems as those arising:

9

- 10 • from the application of a new process, material or subsystem before fully
11 understanding parameters that control cost, latitudes and failure modes;
- 12 • when a previously commercialised technology is extended outside the
13 known domains of the pertinent design rules; and
- 14 • from unexpected interactions arising from a new or unique combination of
15 known subsystems of components.

16

17 Of further interest, the authors⁶² developed a checklist to help technology and
18 product developers audit technology progress, which we have adapted to serve as a
19 tool for minimising the risk associated with introducing new technologies (*i.e.* beyond
20 the development stage):

21

- 22 • Implementation goals confirmed
 - 23 - validate business assumptions and technology specifications for cost,
24 performance and reliability
- 25 • Technology mastery demonstrated
 - 26 - critical parameters identified

- 1 - failure modes identified
- 2 - set risk tolerances relating to the critical parameters so as to avoid
- 3 failure modes and deliver the required performance
- 4 - performance demonstrated using a combination of hardware and
- 5 mathematical simulation
- 6 - manufacturing feasibility established
- 7 • System specifications re-established
- 8 - system and subsystem financial and operational performance targets
- 9 are re-established and re-assessed based on technology specifications
- 10 • Additional assessments completed
- 11 - supporting assessments completed, such as safety and environmental
- 12 impact study
- 13 • Contingency planning
- 14 - develop contingency plans should critical risks materialise in spite of
- 15 control procedures in place

16

17 Wildemann¹⁷⁰ describes a framework for guiding technology planning. Risk

18 profiles are constructed displaying the relative importance of identified threats and

19 opportunities, and thus the inherent ‘attractiveness’ of the technology, complemented

20 by a strengths-weaknesses analysis that estimates the ability of the firm to

21 successfully implement the technology. The author’s aim was to provide an analytical

22 basis upon which strategies may be developed for the introduction of new

23 technologies.

24

25

1 **D. Outsourcing risks**

2

3 Our discussion of risk analysis strategies moves to one of the key features of the
4 international water business – outsourcing. A significant feature of water utility
5 management in recent years has been the growth in outsourcing, defined as the
6 transfer of previously in house activities to a third party. Outsourcing allows utilities
7 to focus on critical functions (core business), access economies of scale, minimise
8 investment, increase quality of service, transfer risk, and reduce administrative
9 burdens including regulatory compliance.^{116,42,36} Common candidates for outsourcing
10 include information technology, maintenance, distribution, manufacturing, and
11 customer care and billing.¹¹⁶ A widely held view is that the potential for outsourcing
12 is far from exhausted. A holistic approach to risk being promoted in this review
13 requires that in addition to the traditional review of legal and regulatory
14 responsibilities following contractual agreement, the process of outsourcing should
15 fall within the remit of corporate risk management. That is, outsourcing alters the
16 boundaries of the firm, and the scope of risk analysis and risk management
17 programmes should be extended to reflect this.

18 Risks are inherent in the process of outsourcing, from the decision to outsource,
19 to the management of agreed contracts. Received wisdom has been that companies
20 should focus on ‘core competencies’ and outsource the remaining parts of the
21 business (although the validity of this distinction has been questioned of late, notably
22 by Heikkilä and Cordon⁶³). The core risks discussed in the literature relating to
23 decisions over what to outsource and who to outsource to include: the loss of key
24 capabilities, developing dependence on the vendor, and risks linked to the service
25 provider’s deficient capabilities. Each decision to outsource must be carefully
26 assessed from a risks and benefits perspective.³⁶ Decision-making frameworks are

1 available for this purpose. Lonsdale's⁸⁶ decision tree for outsourcing provides a
2 framework for evaluating what constitutes an organisation's core competencies, and
3 analysing market opportunities for outsourcing the remaining parts of the business.
4 The framework seeks to ensure managers retain those resources responsible for
5 competitive advantage, avoid monopolistic or oligopolistic supply markets, and
6 effectively manage the risk of post-contractual dependency. A similar model,
7 although focussed at the policy level, is provided by Quélin and Duhamel.¹²⁵ Of
8 course, successful outsourcing further depends on managing supply risks, defined as
9 the transpiration of failures with in-bound goods and services.¹⁷⁶ Core categories of
10 supply risk discussed in the literature include: the financial stability of the supplier;
11 cost fluctuations; capacity constraints of the market and specific suppliers; variations
12 in quality; the ability of the supplier to adapt to required changes in design or
13 technology; and natural disasters. Two diametrically opposed approaches to
14 managing supply risk are the active management of risk interfaces with the intention
15 of reducing vendor failures,¹⁷⁶ and the construction of barriers (*e.g.* safety stock,
16 multiple sources) to buffer the effects of inherent uncertainties.^{46,104} Tools in support
17 of the former approach include qualitative assessments of the financial stability of
18 potential suppliers; formal models for the demonstration of supplier capacity
19 performance; 'what-if' scenario planning; and statistical process control to detect
20 deviations from desired quality.¹⁷⁶

21

22

23 **E. Employee retention**

24

25 Retaining valued employees has long been an implicit component of good
26 utility management. The recent emphasis on people as *the* resource, along with the

1 external realities of an increasingly dynamic and pressurised labour market, have led
2 to the sector embracing employee retention as a critical risk issue – particularly in the
3 technically specialised areas of the water business. This focus is exemplified in recent
4 sectoral research initiatives (e.g. American Water Works Association Research
5 Foundation (AwwaRF) project #2850 ‘Succession planning for a vital workforce in
6 the information age’), and a recent (2001) policy statement from AWWA calling on
7 utilities to establish formal employee retention plans.

8 Maintaining employee retention, thus managing the risk of losing organisation
9 capacity, begins at the recruitment stage (e.g. Barney,⁹ McNally,⁹⁴ Denton³³).
10 Empirical evidence suggests that ensuring a ‘cultural match’ between employees and
11 the organisation plays a critical role in reducing staff turnover.¹⁴¹ The tool applied by
12 Sheridan¹⁴¹ to ‘measure’ culture (beliefs and values) was the Organisational Culture
13 Profile (OCP) instrument developed by O’Reilly *et al.*¹⁰⁹ The OCP assesses
14 candidates by encouraging them to sort value statements on: norms regarding the
15 completion of work tasks; norms regarding interpersonal relationships; and norms
16 regarding individual actions. Utilising the OCP as a part of the recruitment process
17 could provide utilities with a proactive tool for minimising staff turnover, by filtering
18 those most likely to leave the organisation early from the selection process.
19 Additionally, it enables the risk-based targeting of retention efforts, for example by
20 focusing efforts on employees hired regardless of ‘cultural misfit’.

21 This philosophy is mirrored in the work of McNally,⁹⁴ who promotes the use of
22 more traditional tools such as personality assessments at the recruitment stage to
23 ensure ‘good fits’ of personality and work ethic. As Denton³³ notes, whilst “*good
24 recruitment is certainly important, it is what happens to recruits after joining an
25 organisation that determines whether a company will retain them.*” In relation to
26 this, McNally⁹⁴ encourages organisations to develop ‘early warning systems’ to

1 identify employees at risk of leaving. Such a system requires the collection and
2 analysis of retention data by subgroup (*e.g.* ethnicity, gender, function, organisational
3 level, *etc.*) to facilitate identification of ‘at-risk’ groups. Following identification,
4 tools such as employee surveys, employee reviews, mentor or manager feedback,
5 local economic trends, head-hunter activity, and, crucially, the exit interview may be
6 used to determine factors driving high rates of defection.⁹⁴ Adherence to such a
7 system would provide utilities with comprehensive data on who is leaving and why,
8 providing the foundation for developing effective, tailored retention strategies. A
9 recurrent theme of the retention literature is that incentives (*e.g.* salaries and benefits)
10 alone are not enough for achieving high levels of retention, the contention being that
11 retention is related more closely to employee development and intrinsic benefits such
12 as working relationships, job satisfaction and a sense of empowerment (*e.g.*
13 Hagevik,⁶⁰ McNally,⁹⁴ Thompson,¹⁵⁸ Denton³³). Accordingly, utilities may consider
14 undertaking a gap analysis of their employee development schemes (interestingly,
15 Brueck¹⁸ reports that water utilities spend as little as 1% or less of their labour budget
16 on nonmandatory employee training) and benefit programmes before remedying
17 deficiencies in order to minimise turnover rates. An alternative approach to
18 identifying the level of retention risk is to undertake an informal risk assessment⁴
19 which is essentially a checklist addressing the core issues influencing turnover (*e.g.*
20 employee-manager relationships, communication, job satisfaction, *etc.*).

21 The negative consequences of employee turnover are clearly emphasised
22 throughout the literature, leading to the implicit assumption that organisations should
23 ‘pull out all the stops’ to minimise defection rates. However, as Sigler¹⁴⁴ and
24 Mowday¹⁰⁰ contend, the costs of reducing retention may, in some cases, exceed the
25 benefits to be derived. It is thus incumbent on organisations to critically analyse the

1 costs and benefits of implementing retention strategies; the cost-benefit analysis
2 approach offers a promising framework for this purpose.

3

4 **F. Assessing investment risks**

5

6 Behind each strategic investment an organisation considers lies some
7 calculation of the move's worth.⁸⁷ Following Rothstein and Kiyosaki,¹³⁴ we define
8 strategic investments as those resource allocations that will yield substantial advances
9 toward the achievement of a utility's strategic goals. Whether considering a joint
10 venture, acquisition, or a major extension of an existing facility, how the utility
11 estimates value is a critical determinant of how it allocates its resources, which is in
12 turn a key driver of its overall performance.⁸⁷ Valuation methodologies range from
13 the formal (comprising an appraisal model and a supporting theory) to the informal
14 (based on heuristics).⁸⁷ However, since the 1970s there has been a trend towards
15 applying valuation methods that are more formal, explicit, and institutionalised.⁸⁷ The
16 most widely adopted framework is the Net Present Value (NPV) model, which
17 estimates value by capitalising (discounting) future streams of cash flow that the
18 investor expects to receive from an asset. The capitalisation rate is the minimum
19 expected rate of return needed to induce an investor to acquire. Capitalisation is
20 comprised of two components, the risk-free rate of return (accounting for the time
21 value of money) and the risk premium (the additional compensation demanded by
22 investors for assuming risk). Although issues have been raised regarding the
23 applicability of conventional appraisal methodologies to the water industry,
24 specifically relating to the long lifespans of many capital projects and the fact that
25 they often do not generate revenues in the traditional sense (*e.g.* Tebbutt *et al.*¹⁵⁵),
26 they remain favoured by academics and industrialists. Our subsequent discussion

1 focuses on three distinct investment problems: valuation of assets-in-place; valuation
2 of ‘opportunities’; and the valuation of joint ventures.

3

4 *Assets-in-place*

5

6 The most basic valuation problem is valuing assets-in-place, *i.e.* the valuation of
7 an ongoing business or some part of one, for the purposes of informing decisions
8 ranging from a change in suppliers to an acquisition.⁸⁷ It is for such situations that
9 Discounted Cash Flow (DCF) techniques (methodologies for determining the
10 capitalisation rate) are suited.⁸⁷ In brief, the established DCF methodologies include
11 the weighted-average cost of capital (WACC),⁹⁷ the capital asset pricing model
12 (CAPM)¹⁴⁰ and the adjusted present value (APV).¹⁰² The WACC, which establishes
13 the risk premium on the basis of the ‘cost of capital’ financing the investment,
14 remains the most commonly practised approach,⁸⁷ though is increasingly criticised in
15 academic circles (*e.g.* Luehrman,⁸⁷ Gregory⁵⁴). The fundamental idea behind CAPM
16 is to use β , a measure of systemic (market) risk, to adjust cash flows. In contrast,
17 APV seeks to unbundle the various components of value (*i.e.* cash flows), analyse
18 them separately, and then add up the present values. For a fuller discussion of these
19 and other DCF techniques see *e.g.* Modigliani and Miller,⁹⁷ Sharpe,¹⁴⁰ Myers,¹⁰² Berry
20 *et al.*,¹² Gregory,⁵⁴ Luehrman,⁸⁷ and Ye and Tiong.¹⁷³

21 Regardless of the individual strengths and limitations of the above models, a
22 common deficiency is that there is no indication of the confidence level on the
23 determined capitalisation rates.¹⁷³ Following on from Hertz,⁶⁶ who highlighted the
24 misleading nature of single-point estimates in investment analysis, most researchers
25 advocate the appraisal of investments within a non-deterministic framework; the
26 principle being that investment forecasts are, by definition, uncertain. Reflecting this

1 uncertainty in model outputs lends some assurance to the decision-makers that the
2 available information has been used with maximum efficiency.⁶⁶ This is reflected in
3 Guidelines published (1999) by the Asian Development Bank⁶ on the application of
4 financial evaluation methodologies to water supply projects. Risk analysis, in the
5 form of sensitivity analysis and stochastic simulation, is promoted as a means to
6 examine the influence of changes in key underlying variables on forecast cash flows,
7 and the probability that project NPV will fall below zero. Incorporating these
8 principles, Barriex *et al.*¹⁰ describe the application of the NPV framework to the
9 proposed restructuring, privatisation and optimisation of water utility operations in
10 Panama. The focus of their study is on the proposed rehabilitation of systems
11 supplying water to Arraijan, Chorrera, Colon and Panama City, a ‘holistic’
12 programme entailing the upgrading of commercial, technical and operational aspects.
13 Through stochastic simulation and sensitivity analysis of forecast financial returns, the
14 authors confirmed the project’s robustness from a financial standpoint, determining a
15 ‘zero’ probability of negative NPV.

16 Thomas¹⁵⁷ uses an illustrative example to examine the role of CAPM in
17 adjusting for the risk inherent to acquisition / diversification appraisals (using internal
18 rate of return (IRR), an appraisal framework similar to NPV). Accounting for the
19 unique nature of acquisition / diversification appraisals, the author provides a
20 methodology for integrating expected financial and operational synergies (*e.g.* derived
21 from financial and operating economies, or the pooling of functional areas) within the
22 analysis. However, through applying a risk premium to projected cash flows (which
23 by definition accounts for the increased returns investors demand for variable cash
24 flows) and undertaking simulation of the variables influencing future cash flows (thus
25 explicitly modelling the variability of returns), Thomas¹⁵⁷ is effectively ‘double
26 counting’ for risk, introducing a bias against investment decisions. This criticism is

1 supported in the work of Burchett and Tummala,²¹ who apply Monte Carlo simulation
2 to an NPV based appraisal of an infrastructure capital investment decision. These
3 researchers argue that applying specific probability distributions to the relevant
4 variables captures all potential risks relating to the investment, thus negating the
5 requirement for incorporating a risk premium as part of the capitalisation rate.

6 Although it is widely accepted that a probabilistic approach to investment risk
7 analysis is desirable, problems exist. As Songer *et al.*¹⁴⁸ assert, the failure to identify
8 all significant risks (*i.e.* to apply appropriate probability distributions to all relevant
9 underlying variables) quickly undermines model validity and output. A further pitfall
10 is identified by Mosca *et al.*,⁹⁹ who in applying simulation methodologies to a
11 proposed plant investment, found that the choice of frequency distribution chosen
12 (often arbitrarily) for the independent variables can have a marked effect on the
13 process outcome. These are important observations in that they highlight the biases
14 inherent to all risk models, reminding of us of the need to use risk analysis output
15 diagnostically rather than to over-invest belief in quantitative risk estimates.

16 In financial circles, recent times have seen an increasing adoption of tools that
17 can perform economic evaluation and modelling on the combined entity of
18 investments (portfolio) as well as for each individual project. This trend extends
19 beyond the financial sphere, as is illustrated in the work of Rothstein and Kiyosaki,¹³⁴
20 who describe the application of portfolio management theory to water utility
21 investment planning. The philosophy of their approach is to create a portfolio
22 representing a balanced array of investments that mitigate uncertainties and that are
23 likely to realise potential returns. Of particular interest is their use of multi-attribute
24 analysis, which allows the risk-based prioritisation of monetary and non-monetary
25 investment decisions within a single analytical framework.

26

1

2 *Opportunities*

3

4 It is relevant here to further discuss the work of Luerhman,⁸⁷ who categorises a
5 second type of valuation problem – the valuation of opportunities (*i.e.* possible future
6 operations) – as distinct from the valuation of operations (assets-in-place). The
7 distinction is that with the former, the decision to invest may be deferred. In
8 opportunity valuation, risk matters in two ways: the risk of the investment, and the
9 risk that circumstances will change before a decision has to be made – such
10 contingencies are not well handled by the traditional DCF approach.⁸⁷ Luerhman⁸⁷
11 states that a common approach in the valuation of opportunities is simply not to value
12 them formally until they mature to the point where a decision can no longer be
13 deferred, where they can then be valued, in effect, as assets-in-place. Critics have
14 decried this practice, on the premise that it leads companies to undervalue the future
15 and hence underinvest.⁸⁷ In response, Luerhman⁸⁷ discusses the potential of ‘option-
16 pricing theory’¹⁴ - an analytical strategy that allows managers to handle the
17 contingencies created by the time-dependant nature of opportunity valuation - as a
18 supplement, not a replacement, for the valuation method for in place assets.

19

20 *Joint-ventures*

21

22 A further category of investment decisions is found where firms participate in
23 joint ventures, partnerships, or strategic alliances. This takes on particular resonance
24 in the water industry, where recent years have seen a proliferation in public / private
25 partnerships. In such cases, where ownership is shared with other parties, managers

1 need to understand both the value of the venture as a whole *and* the value of their
2 company's interest in it.⁸⁷

3 The investment risks associated with public-private partnerships have been
4 reviewed by Grimsey and Lewis.⁵⁵ Using the financing of Stirling Water, a Scottish
5 design-build-operate contractor as an illustrative example, apply quantitative analysis
6 of returns on investment from the perspective of the private (sponsor) and public
7 (procurer) sector entities.

8 A common observation of the risk management literature is an all too
9 obvious gap between theory and practice. Much of the highly theorized investment
10 literature does not reflect standard industry practice, particularly that relating to the
11 application of complex methodologies such as simulation and scenario analysis. The
12 discrepancy is explained, in part, in that such techniques do not fit naturally into most
13 companies' skill sets or capital-budgeting systems.⁸⁷ Despite this, there is a dearth of
14 literature focussing on the practicalities of integrating such tools deep within company
15 structures. To address this issue and as part of the research that has informed this
16 review, the authors will be undertaking a benchmarking of risk management
17 capabilities within the international water utility sector.

18

19

20 **3. PROGRAMME RISK ANALYSIS**

21

22 We turn to a more familiar discussion of the application of risk analysis to the
23 water utility sector. The revised WHO guidelines¹⁶⁷ are promoting the implementation
24 of water safety plans for water quality management from catchment management,
25 through process control, distribution and on to the tap.¹⁶⁰ Application of risk analysis
26 to these aspects of the water 'supply chain' extends to programmes of work as well as

1 individual plant operations. A discussion of the latter, operational risk analysis
2 follows, but here we are concerned with the analysis of risks associated with
3 programmes of activity that are ‘rolled-out’ across organisations, such as asset
4 management and maintenance planning. Here, managers are responsible for the
5 implementation of strategies across company functions, multiple sites and geographic
6 regions. They are concerned with: evaluating the risks posed by a similar hazard at a
7 variety of locations (*e.g.* mains bursts, network intrusion – in asset management, for
8 example); the risk-based appraisal of operational strategies and long-term planning in
9 relation to the water supply-demand equilibrium; and the wide variety of risks
10 existing within a catchment or watershed. Table 3 summarises the portfolio of
11 analysis techniques available at the programme level.

12

13

14 **A. Asset management**

15

16 In line with Booth and Rogers,¹⁶ we consider asset management as ‘*managing*
17 *infrastructure capital assets to optimise the total cost of owning and operating them*
18 *while delivering the service levels customers desire.*’ Managing risk in the face of
19 limited resources has long been an implicit component of asset management. Within
20 the UK, pressure from the economic regulator has ensured that the explicit
21 incorporation of risk analysis into asset management programmes has taken on added
22 momentum. Water utilities are expected to:

23

24 ‘*demonstrate how the flow of services to customers can be maintained at least*
25 *cost in terms of both capital maintenance and operating expenditure, recognising the*

1 *trade off between cost and risk, whilst ensuring compliance with statutory duties''*
2 *(Ofwat letter MD 161, April, 2000).*

3

4 In addition to regulatory pressures, the global trend towards requiring financial
5 self-sufficiency on the part of public and private utilities has created a climate in
6 which management can no longer seek to 'over-engineer' facilities with the
7 presumption of screening out technical risk. A recent (2004) report¹⁶³ to the US
8 Senate cites "*mounting evidence suggest[ing] that the integrity of the nation's*
9 *[water] infrastructure is at risk without a concerted effort to improve the management*
10 *of key assets...and a significant investment in maintaining, rehabilitating and*
11 *replacing these assets''*. The report goes on to explicitly endorse the role of risk
12 analysis in asset management. More than ever, utilities must now seek to balance
13 spending with risk minimisation. A risk-based approach to asset management
14 requires an integrated, systematic process drawing upon a broad range of
15 methodologies for the identification, analysis and prioritisation of assets-at-risk, from
16 the process to the component level (*e.g.* Lifton and Smeaton;⁸² Booth and Rogers¹⁶).

17 On a national scale, the US Natural Resources Defence Council (NRDC)¹⁰⁶
18 recently (2003) reported on the risk to drinking water quality from ageing pipes and
19 process plant across the US with individual city 'rankings' being informed by water
20 quality data, USEPA compliance records and water utility annual reports. Many
21 water companies have in place risk-ranking procedures to evaluate and rank potential
22 risks across a variety of categories, and thus help inform and prioritise risk
23 management procedures.¹²¹ For example, Radovanovic and Marlin¹²⁶ describe the
24 risk-based approach to water mains asset management in place at Sydney Water
25 (Australia). Budgetary requirements are estimated through the application of
26 KANEW, a statistically based survival model which aids the calculation of pipe

1 rehabilitation and replacement needs for distribution networks. The identification of
2 specific pipes requiring work is external to the model, with separate approaches for
3 trunk and reticulation mains (the latter generally being run to failure). Critical trunk
4 mains are identified by means of a checklist-aided screening approach, wherein
5 preliminary assessments of failure likelihood and consequence are combined to create
6 an overall risk score. This combined risk score is used to identify critical water mains
7 deemed to require more detailed analysis (*e.g.* condition-based assessments). This
8 methodology allows Sydney Water to identify and prioritise water mains in need of
9 rehabilitation / renewal, and to proactively assess budgetary requirements.

10 Louisville Water Company (Kentucky) apply their Pipe Evaluation Model,
11 which integrates data such as pipe age and maintenance history, as a tool for
12 prioritising pipe and water mains for rehabilitation and replacement.¹⁶³ Utility
13 managers report that this model, in combination with wider asset management
14 practices, has helped reduce the frequency of water mains breaks from 26 to 22.7 per
15 hundred miles and the frequency of joint leaks from 8.2 to 5.6 per hundred miles.¹⁶³
16 Seattle Public Utilities adopt a risk-based approach to asset management, considering
17 likelihood and impact of pipe rupture with reference to such factors as age, material,
18 location and historical cost of repair.¹⁶³ Drawing upon this analysis, utility officials
19 were able to delineate their pipe network into areas of critical and non-critical risk,
20 and allocate maintenance and rehabilitation resources accordingly. Through adopting
21 this approach, officials believe that they are using staff resources more efficiently and
22 that, over time, the programme will lead to a reduction in maintenance costs.¹⁶³

23 Kent *et al.*⁷³ describe how risk analysis informs the prioritisation of investment
24 strategies for trunk main maintenance at *Dwr Cymru* Welsh Water. The methodology
25 is based on the available records of asset performance, condition and serviceability,
26 which are stored on the company's WAM (Water Asset Management) database.

1 STRUMAP, a software-based mapping system, allows clustered failures to be
2 considered separately from ‘random’ bursts, a task performed as the former are
3 considered likely to be representative of underlying susceptibilities. For each location
4 where a cluster is identified, specific failure rates are derived. For random bursts,
5 failure data is separated according to pipe material and diameter, with failure
6 likelihood determined by group. STRUMAP further enables consideration of failure
7 consequences, in terms of the number of properties potentially affected by an event,
8 taking into account service reservoir storage. Failure likelihood and consequence are
9 then combined to derive an overall severity score, which in turn informs the
10 derivation of investment requirements. The National Research Council of Canada are
11 currently developing a prototype Water Mains Renewal Planner (WARP),¹²⁷ which is
12 aimed at integrating the most promising breakage analysis models into one discrete
13 decision support tool. At present, WARP consists of three modules: a) analysis of
14 water main breakage patterns; b) short-term operational forecasting; and c) long-term
15 renewal planning. A fourth module is to be added to enable prioritisation of
16 individual water mains for renewal.

17 Foster *et al.*⁵⁰ detail a risk-ranking approach for estimating the relative
18 likelihood of failure of embankment dams by piping. Failure likelihood is assessed by
19 weighting the historical frequency of piping failure with respect to dam zoning, filters,
20 dam age, core soil types, compaction, foundation geology, dam performance, and
21 monitoring and surveillance. The methodology allows the prioritisation of dams-at-
22 risk for more detailed analysis, and is further offered as a check on traditional event-
23 tree methods (see also Seker *et al.*¹³⁹).

24 Failure modes and effects analysis (FMEA), developed by the US military, is an
25 engineering technique that tabulates failure modes of equipment and their effects on a
26 system¹ (Table 4). The failure mode describes how equipment fails (open, closed, on,

1 off, leaks, *etc.*). The failure effect is determined by the system's response to the
2 equipment failure. When FMEA is extended by a criticality analysis, it is known as
3 failure modes, effects and criticality analysis (FMECA).

4 Lifton and Smeaton⁸² detail how Scottish Water apply source-to-tap FMECA
5 studies across their water supply systems as part of their 'asset management toolkit'.
6 This allows priority risks to be identified and subsequently compared across the utility
7 portfolio (*e.g.* various mains, raw and treated reservoirs, treatment works *etc.*) in order
8 to focus attention on the most serious threats to system performance. Infrastructure
9 investment strategies are further informed by the HYSIM-AQUATOR supply-demand
10 model. Of particular interest is their description of the asset risk and criticality
11 scoring system implemented at Scottish Water. The system is designed to assess the
12 relative 'total business impact' of asset failures across the company by reference to a
13 'common currency of risk' (one point equates to £1000 of business impact),
14 facilitating a consistent approach to risk scoring across Scottish Water. Additionally,
15 this scoring system guides the prioritisation of reliability studies at the operational
16 level, which further informs asset management strategy.

17 Given the complexity inherent in describing modes of structural failure and
18 assessing their likelihoods,⁵³ logic models (visual risk schematics, *e.g.* reliability
19 block diagrams, fault tree analysis (FTA) and event tree analysis (ETA), see Figures 4
20 and 5) have found application in support of asset management. Parr and Cullen,¹¹⁷
21 through examining the applicability of logic modelling techniques to dam failure
22 analysis, illustrate how such an approach can inform the prioritisation of expenditure
23 on monitoring, maintenance and remedial works. Similarly, Gray and Powell⁵³
24 promote the use of logic diagrams in aiding the development of risk-based strategies
25 for maintaining asset security. The authors model the interactions leading to failure
26 for each class of aqueduct structure. To this, historic data, or where data is deficient,

1 engineering judgement, are applied in order to derive failure probabilities. A
2 cautionary note is sounded by Latiffe,⁷⁹ who contends that risk analysis, specifically
3 logic modelling, is not yet effective in modelling dam failure. The author cites
4 insufficient statistical data on the deficiencies of structural components as the core
5 drawback.

6

7 *Spatial context of risk*

8

9 Geographic Information System (GIS) technologies now play a critical role in
10 asset management. At its most basic level, GIS allow utilities to convert data
11 ordinarily displayed on paper maps into one single, easily accessible digital format,
12 representing an excellent method for storing and collating data for future use.⁴⁹ The
13 level of detail (*i.e.* the layers of spatial data) contained within such systems varies
14 widely. Kaufman and Wurtz⁷² describe the evolution of a GIS for a small utility
15 (Beecher Water District, Michigan). An extensive inventory of asset condition
16 records and failure and maintenance data is collated within the system, supporting the
17 risk-based planning of capital improvement and maintenance works. Pertinently, the
18 system took only three months and less than \$3,000 to develop. Similarly, Booth and
19 Rogers¹⁶ illustrate how the implementation of GIS technologies within an asset
20 management decision support system can allow for the visual tracking of
21 infrastructure assets and their associated risk factors.

22 Although applications of GIS technologies in support of asset management have
23 proven to be powerful risk-tracking, visualisation and communication tools,¹⁶ they
24 rarely utilise the capabilities of GIS to spatially analyse data in the classical sense.⁴⁹
25 Doyle and Grabinski³⁷ illustrate these capabilities through quantitatively relating
26 Toronto's infrastructure deterioration to spatially variable corrosion risk factors,

1 providing a basis for the identification of network areas most at risk from external
2 corrosion. Such an approach may allow utility managers to better focus rehabilitation
3 efforts through having a more complete understanding of the causative factors behind
4 water main deterioration. Of further interest is the work of Ta,¹⁵³ who describes the
5 application of a probability model for burst risk studies of water mains. Contributing
6 factors (*e.g.* pipe number density, pipe age, material and diameter, soil corrosivity,
7 *etc.*) are represented as GIS data layers and correlated with past failure data in order to
8 deduce burst probability scores for each water main. The tool, developed for Thames
9 Water Utilities Ltd. (UK), is not intended to predict the likelihood of pipe bursts,
10 rather to aid utilities in sourcing the origin of an area burst (*i.e.* following a pipe burst
11 in the area, the value of probability evaluated for a particular pipe section would
12 indicate the likelihood that the burst actually occurred at that section).

13 While GIS represent powerful tools for spatial data analysis, their inherent
14 capabilities for complex and dynamic analysis are limited.^{152,43} In contrast, traditional
15 simulation models are powerful tools for complex and dynamic situations, but often
16 lack the intuitive visualisation and spatial-analysis functions that GIS offers.^{152,43}
17 Consequently, researchers have sought to couple these systems. Lindley and
18 Buchberger⁸³ describe the integration of hydraulic modelling within a GIS for the
19 purpose of assessing intrusion susceptibility in distribution systems. The holistic
20 methodology enables the synthesis of multiple risk factors describing the three key
21 (geographically variable) susceptibility conditions of adverse pressure gradient,
22 intrusion pathway, and contaminant source, thus identifying areas susceptible to
23 intrusion (accidental or intended). Susceptible locations are then prioritised for
24 attention by considering how they are hydraulically connected to local sensitive
25 populations. In addition to informing asset management programmes, this framework
26 may also be applied in a reliability context at the design stage. Similarly, Besner *et*

1 *al.*¹³ illustrate *via* case study how the coupling of a GIS containing structural,
2 operational and water quality parameters with simulation model EPANET facilitates
3 the identification of key factors responsible for water degradation in the distribution
4 network. Through identifying network areas presenting the greatest risk, this
5 technique can inform the prioritisation of risk management strategies.

6

7

8 **B. Catchment management**

9

10 The concept of catchment (or watershed) management has gained widespread
11 international support, representing a shift from the sole reliance on end-of-pipe
12 treatment technologies for point sources towards the watershed-specific prioritisation
13 of water quality problems and their integrated solution.⁴⁸ An outcome of this is that
14 the assessment of hazards to the quality of water resources within a catchment is
15 increasingly subject to formal risk assessment and can be expected as part of routine
16 water safety plans.^{160,161,167} In Europe, the DPSIR approach to identifying key
17 hazards within a watershed, by reference to the driving forces (*e.g.* population growth),
18 pressures (sewer discharge), state (increased nutrient load), impacts (anthropogenic
19 eutrophication) and policy response (discharge control) is being adopted under the
20 European Water Framework Directive.⁷⁰ Here, risk assessments of activities posing a
21 an actual or potential threat to the quality of water bodies in ‘river basin districts’ are
22 intended to inform and help prioritise a programme of multi-agency action plans
23 targeted at raising the overall ecological status of the watershed within statutory
24 timescales. Given the plethora of potential catchment management issues in any
25 improvement programme, there is a need to prioritise risk management efforts within
26 the watershed by concentrating on those measures that reduce the significant

1 likelihood of severe impacts being realised. Southern Water (UK) adopt a semi-
2 quantitative ranking scheme in screening their groundwater sources for
3 *Cryptosporidium* contamination risk, as described by Boak and Packman.¹⁵ The
4 methodology consists of ranking source waters across ten risk categories (*e.g.* land
5 use) using pre-determined scoring hierarchies (*e.g.* occasional livestock grazing: 2),
6 before combining these category rankings into an overall weighted risk score.
7 Through this approach the utility identifies those sources deemed to be at significant
8 risk of oocyst contamination, and which therefore require continuous monitoring (in
9 line with regulations).

10 Given the improved capabilities and functionality of modern GIS and their
11 inherent ability to map and analyse data that is spatially variable in nature, many
12 catchment-level ranking methodologies have sought to incorporate their benefits.
13 Various authors^{88,146,169,49,111,51} describe the use of map overlay techniques (which
14 essentially combine the attributes of two or more data layers across geographic space)
15 in the identification and mapping of areas critical to catchment water quality. These
16 risk-mapping (essentially spatial risk-ranking) methodologies centre on the analysis of
17 those spatial attributes considered to play a significant role in pollutant transport (*e.g.*
18 geology, rainfall, soil type, agricultural activities *etc.*) according to pre-defined
19 formulae (*e.g.* a weighted runoff-potential index). Their focus may be generic or
20 targeted towards specific hazards (*e.g.* animal feeding operations) or pollutants (*e.g.*
21 through incorporating measures of their leaching potential).

22 Risk-ranking methods are applied to help target more detailed analysis towards
23 critical risks and to inform the prioritisation of catchment management activities,
24 specifically monitoring programmes. Of course, the potential exists that as the costs
25 of planned monitoring decrease on the one hand, the risks may increase on the other.
26 When designed well, piloted and implemented with feedback, risk-based resourcing

1 strategies (Figure 6) can provide a sound basis for distinguishing greater risks from
2 lesser ones, and for investing resources in risk management that are proportional to
3 the risks posed.¹²²

4 Most critically, however, these risk-based optimisation tools, whether intended
5 to drive monitoring regimes, maintenance schedules or workforce planning, may
6 themselves incur significant risk unless the consequences of resource trade-offs are
7 themselves assessed. Consider the actions of the Saskatchewan Department of
8 Environment and Resource Management (SERM) prior to the North Battleford
9 *cryptosporidiosis* outbreak in April 2001.¹²¹ SERM held legislative responsibility for
10 the Saskatchewan drinking water programme and, partly in response to budget cuts in
11 the mid 1990s, drastically reduced the already limited field inspection and
12 enforcement of municipal utilities. This culminated in SERM proposing to eliminate
13 its drinking water programme altogether, a motion tentatively approved by the
14 Treasury Board in 2000/01 and justified as being ‘risk-based’. The subsequent North
15 Battleford outbreak, infecting between 5800 to 7100 persons in the immediate
16 community plus a large number of visitors from three other provinces, led to a public
17 inquiry into the outbreak and the provincial drinking water regulatory system. Justice
18 Laing⁷⁶ concluded in his Inquiry report: “*that the current risk-based model employed*
19 *by SERM since 1996 is arrived at on the basis of economics, and has nothing to do*
20 *with how best to safeguard the health of the population, all of whom consume water*”.
21 The example aptly illustrates the inappropriate use of risk analysis as a justification
22 for the removal of processes critical to public health protection. Tensions that arise
23 between those seeking economic efficiencies and preservation of the principal goal of
24 providing safe drinking water are often played out in the conflicting expectations and
25 presumed purposes of risk analysis made by different professionals. The real
26 consequences of stripping away levels of safety, precaution and protection using ‘risk

1 analysis' as a justification can be to render the system as a whole less safe, more
2 precarious and more susceptible to catastrophic failure and so optimisation
3 programmes, maintenance schedules and risk-based monitoring require special
4 scrutiny as to the balance between risk and the full cost of implementing these
5 programmes.

6 Where more detailed analysis is deemed necessary, a common recourse is to
7 model-based approaches. Water quality and flow / transport models represent core
8 tools for this purpose, due to their combined ability to model the dispersal of
9 pollutants and predict the resultant deterioration of water quality. Aside from the
10 inherent value of fostering an increased understanding of catchment water quality
11 issues, the core benefits of model-based analysis stems from their ability to test
12 management scenarios (through *e.g.* sensitivity and scenario analysis), thus enabling
13 informed decisions on how best to manage the resource. A range of models are
14 available that apply to catchment risk analysis, from micro to landscape scales, from
15 deterministic to stochastic approaches (Table 3).

16 Common practices of hydrological and water quality modelling have been based
17 mostly on deterministic analysis, producing single point estimates that neglect
18 prediction uncertainty.² Determinism has been embraced by many risk analysts, for
19 example, Gündüz *et al.*⁵⁶ describe the use of the combined hydrodynamic and water
20 quality model CE-QUAL-W2 in projecting potential water quality degradation
21 patterns under different pollution loads. The tool is intended to aid management in
22 the development of appropriate strategies for the management of water quality.
23 Similarly deterministic approaches to catchment analysis are described by various
24 other researchers (*e.g.* Cole *et al.*²⁵). The limitations of determinism in risk analysis,
25 discussed earlier, are particularly relevant in the context of hydrological and water
26 quality modelling, considering the often scarce or incomplete data available.⁸⁹ This

1 uncertainty takes on particular importance from the utility standpoint, as their
2 assessments of catchment water quality are performed with regard to set regulatory
3 standards. To illustrate this point, the uncertainties inherent in flow and contaminant
4 transport modelling (from *e.g.* spatial variability, data scarcity, model imperfections)
5 imply that there will always be a risk of exceeding a given standard at some point
6 over space or time following a pollution event, regardless of the estimated single-
7 point (mean) contaminant levels.²

8 An argument can thus be forwarded for the explicit consideration of prediction
9 uncertainties in catchment level risk modelling. There exist two dominant approaches
10 towards this task: stochastic modelling; and deterministic modelling allied with
11 uncertainty analysis of the output. Adopting the former approach, Andersson and
12 Destouni² outline the application of stochastic transport modelling to quantify the risk
13 of exceeding regulatory standards for groundwater at any point on the compliance
14 boundary. This quantification is coupled with an analysis of the abatement costs
15 required to attain an ‘acceptable’ risk level. Halfacree,⁶¹ for example, describes the
16 use of PRAIRIE, an aquatic dispersion modelling tool for assessing chemical
17 pollution risks to water bodies. The main elements are an aquatic dispersion model;
18 hydrological, substance and standards databases; and a tabular / graphical output
19 facility. The model has a deterministic mode used to ‘screen out’ low risk sites, and a
20 probabilistic mode for more detailed analysis of high risk sites. The output results
21 (*e.g.* frequency versus concentration curves) are compared with pre-determined
22 criteria to inform regulatory actions on risk management from hazardous activities
23 within a sensitive catchment. An advantage of the stochastic approach is that
24 uncertainty is interwoven within the model.¹⁷⁵ However, the solution of stochastic
25 equations is often impractical for complex problems.⁸¹ This explains, in part, the

1 preference for deterministic approaches to water quality / hydrological modelling,
2 creating the subsequent need for external consideration of output uncertainty.

3 In this context, uncertainty analysis is performed to estimate the probability of
4 obtaining a given output value when uncertainties on input variables and parameters
5 are known.⁸⁹ Liou and Yeh⁸⁴ outline the use of a groundwater transport model in
6 deriving the risk of contaminant concentration exceeding a maximum acceptable
7 upper limit (*e.g.* regulatory standard). The analytical uncertainty of the predicted
8 contaminant concentration is derived by first-order mean-centred uncertainty analysis,
9 prior to the application of Monte Carlo simulation in order to compute the mean risk
10 and associated confidence interval of exceeding standards. For detailed discussions of
11 the forms of uncertainty in water quality modelling and the techniques for their
12 analysis, see Mailhot and Villeneuve,⁸⁹ Portielje *et al.*,¹²³ and Beck.¹¹

13 In the event of pollution leading to a violation of water quality standards,
14 remediation may be required. Researchers have developed methodologies for
15 optimising remediation strategies (*e.g.* Rogers *et al.*¹³²). However, as Latinopoulos *et*
16 *al.*⁸⁰ contend, if the inability to meet the constraints of a groundwater quality
17 programme is considered a significant risk, then quantifying the risk of remediation
18 failure in terms of failure to comply with regulatory standards is a primary task. In
19 relation to this, Latinopoulos *et al.*, through coupling stochastic flow and transport
20 simulations with a risk-cost-benefit objective function, have developed a methodology
21 facilitating the risk-based evaluation of remediation strategies (costing the risk of
22 failure in terms of regulatory fines and the need to import / develop alternative
23 supplies).

24 An alternative approach to characterising the extent and severity of source
25 contamination is that of geostatistical inference (*e.g.* Passarella *et al.*,¹¹⁸ Wingle *et*
26 *al.*,¹⁷¹ Rautman and Istok¹²⁹). These kriging methods – essentially a form of least

1 squares linear regression – focus on providing an estimate of a spatially distributed
2 variable (*e.g.* contaminant concentration) at unsampled locations as a function of a
3 limited set of sample values taken from surrounding locations.¹²⁹ As such, they are
4 ideally suited to groundwater quality issues, where data collection is limited by
5 expense and access. Of particular relevance to risk analysis is the discipline of
6 geostatistical simulation, where multiple, unique estimates of site conditions that
7 mimic the random variability of the parameter(s) of concern are produced.¹⁷¹ Various
8 authors^{118,171,129} have illustrated how such an approach may answer the following
9 questions: what is the probability that contaminant levels exceed regulatory standards;
10 where are the compliance boundaries (and what is the associated level of confidence);
11 and how much contaminant is present (and hence, how much must be removed)?
12 Although the principles of geostatistical simulation are well established, the technique
13 has yet to be widely applied to problems of groundwater contamination.¹²⁹

14 Applications of GIS to catchment risk analysis were discussed earlier in the
15 context of risk-mapping. Although representing efficient risk screening tools, their
16 ability to quantify risk over space *and* time is limited. To counter this, researchers
17 have sought to integrate these systems with simulation models. Feijtel *et al.*⁴⁴
18 illustrate that the embedding of chemical fate prediction models within a GIS allows
19 for calculation of the distribution of predicted environmental concentrations, both in
20 space and time, of ‘down-the-drain’ chemicals in catchment surface waters. Similar
21 approaches are adopted by Dabrowski *et al.*³⁰ and Verro *et al.*¹⁶⁴ to assess surface
22 water pesticide loading.

23

24

25 **C. Network analysis**

26

1 A water distribution system may be viewed as an interconnected collection of
2 sources, pipes, and hydraulic control elements (*e.g.* pumps, valves, regulators, tanks)
3 delivering water to consumers in prescribed quantities and at desired pressures.¹¹²
4 System behaviour, which is governed by hydraulics, supply, demand, and system
5 layout, may be described mathematically.¹¹² This description forms the basis of water
6 supply and distribution modelling (network analysis), a discipline practised in the
7 water industry for many years, particularly to inform the development of operational
8 strategies.^{154,17} Water utilities routinely apply network analysis in order to assess their
9 ‘security of supply’, defined as the probability of being able to meet consumer
10 demands (*i.e.* network reliability). ‘Best practice’ utilities extend their analysis
11 beyond routine operating conditions to examine network performance under various
12 supply-demand scenarios, thus reflecting the inherent uncertainty of the supply-
13 demand balance. The standard Scottish Water methodology of yield assessment uses
14 the software tool HYSIM-AQUATOR.⁸² HYSIM, a hydrological rainfall-runoff
15 simulation model, is used to derive historic inflow series, based on historic rainfall,
16 potential evapotranspiration, and if necessary any artificial influences (*e.g.*
17 abstractions). AQUATOR, a water resource system model, uses the output from
18 HYSIM to simulate reservoir storage based on system demands and compensation
19 flows. The model assists Scottish Water in understanding the level of supply
20 availability risk in the current system and in determining the impact of prospective
21 investment strategies to mitigate this risk.

22 Stevens and Lloyd¹⁵⁰ describe the application of the resource modelling package
23 WRAPsim, with reference to the Yorkshire Water (UK) Grid. The model contains
24 over 1200 components including all river and reservoir sources, boreholes, water
25 treatment works, pipelines and demand centres. Through simulation of the
26 conjunctive use of Yorkshire Water’s sources over a given time period, model output

1 provides the decision-maker with an accurate assessment of the behaviour of each
2 source, its ability to meet demand, and the frequency of restrictions that would need to
3 be imposed. Further insights are gleaned through the application of scenario analysis,
4 wherein the supply-demand balance for each zone under variable scenarios (*e.g.*
5 average year, dry year, peak week, *etc.*) allows an assessment of security of supply
6 over a range of timescales and operating conditions. The authors report that
7 WRAPsim's ability to predict future supply conditions, to optimise allocation of water
8 resources, and to rebalance stocks, has significantly increased the yield and reliability
9 of Yorkshire Water's supply system.¹⁵⁰

10 Stahl and Elliott¹⁴⁹ discuss Essex and Suffolk Water (ESW)'s use of the risk-
11 based resource planning and operational support model DROP (Drought Reliable
12 Output Programme), an adaptation of WRAPsim designed to accommodate the
13 utility's specific technical requirements. The model has been applied in a variety of
14 areas, particularly in support of investment planning and the determination of
15 operational strategies. The authors state that DROP has enabled ESW to improve
16 their understanding of system performance, identify new schemes or short term
17 options to improve reliability of supply, and to more accurately determine future
18 operating costs associated with new developments. Such methodologies, although
19 able to examine system reliability under a range of operating conditions, do not
20 adequately address whether the system is *sufficiently* reliable, as this requires the
21 definition and quantification of appropriate and meaningful reliability measures, a
22 computationally difficult task.¹¹³ Harnessing developments in computer processing
23 power and operability, Ostfeld¹¹³ has developed a methodology for the explicit
24 reliability analysis of water distribution networks, with reliability defined, quantified
25 and measured as the probability of zero annual shortfalls. The methodology, whose
26 development was funded with the intention of practical application by the Israeli

1 Water Commission, is comprised of two interconnected stages: (i) analysis of the
2 storage-conveyance properties of the system; and (ii) implementation of stochastic
3 simulation through use of RAPTOR (Rapid Availability Prototyping for Testing
4 Operational Readiness) software.

5 However, researchers in the field of network analysis are increasingly aware of
6 the need to take account of both the frequency and severity of modelled failures, and
7 as a result analyses are often suggested to extend beyond measures of reliability to
8 incorporate resiliency (*e.g.* the capacity of a system to recover to a satisfactory state
9 from a state of failure) and vulnerability (*e.g.* a measure of failure significance).^{165, 71}
10 Adopting this paradigm, Zongxue *et al.*¹⁷⁴ describe the coupling of a risk model
11 (comprising measures of reliability, resiliency and vulnerability), which incorporates
12 predictions of water demand, with a traditional network simulation model. The
13 approach aids the identification of operational strategies of minimum risk under given
14 supply and demand scenarios, and is illustrated by application to Fukuoka Water
15 Supply System, Japan (see also Jinno *et al.*⁷¹). Similar methodologies are described
16 by Wang *et al.*;¹⁶⁵ Merabtene *et al.*;⁹⁶ and Andreu *et al.*³ though supplemented with
17 formal optimisation procedures to assist derivation of the most appropriate operational
18 policies of minimum risk.

19 To summarise, network analysis can: (a) allow utilities to assess their
20 susceptibility to various supply-demand scenarios (*e.g.* drought or increases in
21 demand); (b) aid decision-makers in determining ‘optimal’ supply strategies and
22 policies; (c) assist in the design phase of distribution networks; and (d) inform the
23 need for capital expenditure.

24

25

1 **D. Vulnerability assessments**

2

3 Operational disruptions are the inevitable result of large-scale disasters (*e.g.*

4 flooding, drought, earthquakes, terrorism). To minimise the risks posed by such

5 ‘uncontrollable’ events, utilities must seek to eliminate or reduce their potential

6 consequences – this is best achieved through contingency and emergency planning.¹⁴²

7 The role of formal risk analysis in emergency planning, long restricted to drought

8 management, is now being widely adopted to address security risks. This is largely in

9 response to the events of September 11th, 2001. In relation to this, a methodology for

10 vulnerability assessments has been developed by Sandia National Laboratories (SNL)

11 – known as Risk Assessment Methodology for Water Utilities (RAM-W). The

12 methodology allows utilities to conduct a detailed assessment of their system

13 vulnerabilities and to develop measures to reduce the risks and mitigate the

14 consequences of terrorist or other criminal attacks.¹⁴⁷ The assessment comprises three

15 steps:¹⁴⁷

16

- 17 1) determine how well the system detects a problem, which involves
 - 18 surveying all security and monitoring features (*e.g.* how quickly could it
 - 19 detect an undesired chemical being introduced to the supply);
 - 20 2) measure delay capabilities in order to determine how well a system can
 - 21 stop undesired events (*e.g.* security in place, length of storage time); and
 - 22 3) measure the capacity of private guard forces and local, state and federal
 - 23 authorities to respond to an event.
- 24

1 Perhaps a more pragmatic approach, particularly for smaller utilities, is found in
2 the questionnaire-based self-assessment developed by the National Rural Water
3 Association.¹⁰⁷

6 **4. OPERATIONAL RISK ANALYSIS**

8 Our review now progresses to the analysis of individual plant. Operational risk
9 managers are responsible for the risks associated with specific operations at plant
10 level – for example, the risk of failure of a device or process component, or the risk of
11 exceeding a particular water quality standard and they are increasingly responsible for
12 the health and safety of plant operatives. Analysis at this level is largely concerned
13 with the ‘classic’ risk analysis methodologies developed and established within other
14 process industries, most notably the oil and chemical sectors (Table 5).

17 **A. Public health and compliance risk**

19 Here, we are primarily concerned with the risk posed by specific contaminants
20 at the plant and distribution system level, particularly relating to the hazards posed to
21 human health and the related risk of exceeding regulatory standards. The multiple
22 barrier approach to water treatment has been the central tenet of modern water
23 treatment systems and relies upon the use of ‘in-series’ water treatment processes to
24 remove hazardous agents from the public water supply. Failure or inadequacy of the
25 treatment and distribution process can result in an interruption of supply and / or
26 derogation in water quality (microbiological or chemical) with potential impacts on

1 public health. The underlying causes may include source contamination, human error,
2 mechanical failure or network intrusion. The consequences of process failure can be
3 immediate, there is very little time if any to reduce exposure because of the lag in
4 securing monitoring data and the impacts can affect a large number of people
5 simultaneously.¹²¹ Beyond the paramount impacts on public health through the direct
6 ingestion of contaminated drinking water, financial and consumer confidence impacts
7 invariably ensue. The financial costs to the community of the fatal Walkerton
8 outbreak for example, were in excess of Cdn\$65 million, with one time costs to
9 Ontario estimated at more than Cdn\$100 million.¹⁰⁸ Compounding this, the loss of
10 consumer confidence following disease outbreaks is often enormous.⁶⁷ Even when
11 there is no legislation covering certain aspects there can be claims of negligence
12 against operating companies. Litigation for civil damages have been prominent
13 features following both the Walkerton outbreak (settled out of court) and the Sydney
14 Water crisis (largely dismissed, costs still incurred).¹²¹

15 Conventionally, the public health impacts of drinking water consumption have
16 been assessed retrospectively using epidemiological studies.⁶⁹ Recognition of the
17 need for a preventative approach to managing risk and providing safe drinking water,
18 however, has driven international interest in the application of risk assessment
19 methodologies within the sector, for both chemical and microbiological hazards.^{5, 59}
20 The generic approach is based on the risk assessment framework developed by the
21 National Academy of Sciences (NAS),¹⁰³ which consists of four key steps:⁵⁹

- 22 • problem formulation and hazard identification – to describe the human health
23 effects derived from any particular hazard (e.g. infection, carcinogenicity, etc.)
- 24 • exposure assessment – to determine the size and characteristics of the
25 population exposed and the route, amount, and duration of exposure

- 1 • dose-response assessment – to characterize the relationship between the dose
- 2 exposure and the incidence of the health effects
- 3 • risk characterization – to integrate the information from exposure, dose-
- 4 response, and health interventions in order to estimate the magnitude of the
- 5 public health problem and to evaluate variability and uncertainty

6

7 Several substantive differences exist between assessment of risk of microbial
8 agents and assessment of risk of chemicals.⁵⁸ Accordingly, the NAS approach has
9 been adapted to account for the dynamic and epidemiologic characteristics of
10 infectious disease processes,⁴⁵ to form what is known as quantitative microbial risk
11 assessment (QMRA). The application of these models has long been the basis for the
12 derivation of water quality guidelines for drinking water.¹⁶⁸ The substance-specific
13 health risk assessments that have historically informed the guidelines may, however,
14 be somewhat distanced from the immediate operational context of individual
15 utilities.¹²¹ However, recent work has extended the application of these models to the
16 operational (plant-specific) context. For example, Medema *et al.*,⁹⁵ Masago *et al.*,⁹⁰
17 and Teunis *et al.*¹⁵⁶ describe the application of QMRA in determining the public
18 health risks posed by the presence of microbial contaminants in treated water. The
19 first step in the process is to define the relationship between measured pathogen
20 source levels and the consumed dose (incorporating analytical detection levels,
21 treatment removal efficiencies, drinking water consumption), followed by the
22 construction of a deterministic model mathematically describing this relationship.
23 Monte Carlo simulation (a method of uncertainty analysis) is then applied to the
24 output of the deterministic model to determine the distribution of the daily consumed
25 dose, to which the relevant dose response relationship is applied in order to determine

1 the cumulative distribution of the probability of infection. From this, the mean annual
2 individual risk of infection may be determined. Such approaches are of particular
3 relevance in areas, such as the Netherlands, where water supply legislation expresses
4 acceptable health risks in terms of infections per year.⁹⁵ Of course, core microbial
5 standards generally refer to a maximum level of organisms in the treated water, and so
6 consideration of consumption levels and the dose-response relationship is superfluous
7 to compliance risk assessment. The approach perhaps has most utility in ‘what-if’
8 mode to answer questions such as: “*what are the public health implications of a*
9 *failure of part of the treatment process or of a re-designing of the treatment*
10 *process*”.⁵²

11 Tools are available to assess the risk of exceeding water quality standards
12 relating to physical or chemical parameters. For example, Demotier *et al.*³² describe
13 an integrated FTA / FMEA approach to determining the risk of producing non-
14 compliant drinking water across a range of parameters, taking into account the quality
15 parameters of raw water and the removal efficiencies and reliability of the full set of
16 treatment processes. Similar methodologies are described by Eisenberg *et al.*⁴¹ and
17 Haas and Trussell⁵⁷ in assessing the reliability of multiple, independent barriers in
18 water treatment. These three pieces of research explicitly consider the performance
19 variability of individual processes along the treatment line, an approach rarely
20 described in operational QMRA. Not only does this offer a more realistic appraisal of
21 compliance risk, it is in line with recent proposals from regulatory bodies (*e.g.*
22 National Health and Medical Research Council (NHMRC))¹⁰⁵ calling on utilities to
23 formally adopt the multiple barrier approach to risk management to ensure multiple
24 levels of protection are afforded against specific contamination threats (see Rizak *et*
25 *al.*¹³¹).

1 Of course, limitations in resources (human and financial) and in the data to
2 underpin such sophisticated analyses often restrict the practical application of these
3 more advanced methodologies within the sector. A more pragmatic analysis of the
4 risks of process failure is commonly undertaken using a semi-quantitative risk-
5 ranking of hazards according to their likelihood and consequence. Egerton⁴⁰
6 describes the application of ranking techniques for the prioritisation of contamination
7 risks at a water treatment plant. Risks are scored according to the frequency with
8 which they may occur, the ability to take action to contain the event, and the
9 consequence of subsequent contamination. The methodology is intended to aid the
10 targeting and prioritisation of remedial actions. Such approaches rely heavily on the
11 experience and judgement of the assessment team, and depending on the level of
12 guidance provided for scoring within these criteria, remain open to bias especially
13 from unforeseen circumstances that often fall beyond the process boundary, *e.g.*
14 deliberate or accidental human error.

15 Finished water can undergo a variety of physical, chemical, and biological
16 changes during transportation through a distribution system.¹³ Understanding the
17 nature and likelihood of these risks has become a priority for water producers,¹³ in
18 part due to research linking such degradation to the incidence of gastrointestinal
19 illnesses (*e.g.* Payment *et al.*¹¹⁹). Application of the methodologies developed by
20 Lindley and Buchberger⁸³ and Besner *et al.*,¹³ described earlier (see *Asset*
21 *management*), would provide utilities with a means to distinguish areas of the
22 distribution system at greatest risk of degradation, providing a framework for
23 prioritising risk management activities.

24

25 **B. Reliability analysis**

26

1 It is implicit in the planning, design and operation of water utilities that risk
2 analysis is a qualitative component of the intellectual process of the experienced
3 engineer / operator. Reliability analysis seeks to formalise, systemise, and, where
4 necessary, quantify this process. Assessments of operational reliability range from
5 component (*e.g.* risk of valve failure), process (*e.g.* risk of failure of treatment step) to
6 network (*e.g.* network reliability under drought conditions, see *Network analysis*)
7 level analysis. Regardless of focus, the aim is to identify the potential failures that
8 may occur in a system, their effects and their likelihood, thus aiding the identification
9 of critical components and processes where design and operational changes are
10 required to meet safety and / or production targets.¹⁵¹ Analysis may be summarised as
11 follows:¹⁵¹

12

- 13 • system definition – defining the level of analysis;
- 14 • failure identification – identifying potential hazards (*e.g.* HACCP, hazard and
15 operability studies, FMEA / FMECA);
- 16 • reliability modelling – to describe failure behaviour of system as a whole
17 (*e.g.* FTA, ETA, reliability block diagrams); and
- 18 • sensitivity analysis

19

20 The National Health and Medical Research Council (NHMRC), the body
21 responsible for issuing drinking water guidelines to Australian water utilities, in their
22 ‘Framework for Management of Drinking Water Quality’^{131,105} advocated the
23 application of a HACCP (hazard analysis critical control points) methodology, namely
24 the determination of ‘critical control points’ whereupon risks can be monitored and
25 reduced.²⁴ Hellier⁶⁴ describes the implementation of this approach within Melbourne
26 Water (Australia). The process begins with the division of the water system into four

1 discrete subsystems: catchment, treatment, distribution and customer premises.
2 Across each subsystem (*e.g.* catchment) the sources of risk to water quality (*e.g.*
3 native animals) and the associated hazards (*e.g.* bacteria, viruses) are identified and
4 plotted on a simple risk matrix; those risks deemed to be significant are evaluated
5 further for their critical control points. Assessors then identify the critical limits,
6 monitoring systems and corrective actions for each CCP. The application of HACCP
7 to South East Water Ltd.'s (Australia) distribution and reticulation systems is
8 described in Mullenger *et al.*¹⁰¹ Through implementing their HACCP plan, the
9 company has developed a greater understanding of water quality issues, refined and
10 optimised operating procedures, and observed a net decrease in customer complaints.
11 These benefits stem from an increased knowledge and understanding of the water
12 supply system and an improved ability to identify potential risks to water supply /
13 quality.¹⁰¹ Beyond managing existing process control, HACCP may also be used to
14 assess and manage the risks from proposed operational changes, such as the
15 integration of treated domestic wastewater to an existing potable production process
16 (*e.g.* Dewettinck *et al.*³⁴).

17 HAZOP (hazard and operability study), a technique developed by Imperial
18 Chemical Industries Ltd., systematically evaluates the process and engineering
19 intentions of new or existing facilities in order to identify the hazards that may arise
20 due to deviations from design specifications.¹ Typically, a carefully selected team
21 examines a process (*e.g.* disinfection) subdivided into 'nodes', at each node, the team
22 applies guidewords (*e.g.* low) to process parameters (*e.g.* ozone levels) to identify
23 ways in which the process may deviate from its design intention, before evaluating the
24 causes and consequences of the deviation. A technical document published by the US
25 Department of Energy¹⁶² describes the undertaking of a HAZOP study on the partially
26 installed chlorination process of a water treatment facility. The analysis, conducted in

1 response to regulatory requirements, identified the key areas of uncertainty (*e.g.*
2 chlorine cylinder received overfilled). ‘Action items’ and recommendations were
3 formulated to clarify these uncertainties and to verify process conditions (*e.g.* check
4 pressure potential from the chlorine cylinder and the system response).

5 The practical implementation of many of these techniques is often constrained
6 by the institutional capacity of organisations and the skill sets available at the
7 operational level. Risk analysis remains an expert discipline and many organisations
8 are more comfortable with the historic and proven implicit approach to risk
9 management. Nevertheless, we are witnessing a growing number of utilities making
10 their analysis more explicit and using these tools for better decision-making,
11 identifying risk issues early rather than later, when their ability to respond may be
12 compromised. At Scottish Water, for example, FMECA-based studies are performed
13 at the operational level. Targeted by a risk criticality scoring system, the analysis
14 systematically considers various components of the water supply system and their
15 respective failure modes.⁸² As the scoring system is ‘pseudo-economic’, decision-
16 makers are empowered to assess the costs and benefits in terms of risk reduction per
17 pound of mitigation efforts through undertaking simple scenario modelling.⁸² Where
18 identified failure modes are traced to specific mechanical or electrical equipment, the
19 equipment is subject to reliability centred maintenance – the risk-based prioritisation
20 of maintenance activities. In recognition of the dangers of ill-informed risk-based
21 resourcing, select critical-risk assets undergo formal optimisation of maintenance task
22 cost-risk-performance using a suite of asset performance tools (APT).

23 These methodologies represent an informed and structured, if time-consuming,
24 framework for pinpointing weaknesses in utility design and operation. Applied
25 effectively using personnel with appropriate skills, experience and resources, they
26 provide operational management with a basis for improving process reliability and

1 identifying issues early. Ineffectively applied, they become little more than acronyms
2 for complacency. As discussed, reliability analysis may require a quantitative
3 treatment of the effect of identified risks at the system level. The importance and
4 complexity of this task has increased in recent years, due in part to the increased range
5 of available technologies and the tighter operational margins imposed by regulators.⁴¹

6 For unreliable or heavily used equipment, an analysis of historic data may be
7 sufficient for this purpose. In the absence of such data, there is a requirement for the
8 formal modelling of risk consequences. There exist a range of techniques for this
9 task, including logic modelling (*e.g.* Demotier *et al.*;³² Cyna²⁹), ‘quantitative’ FMECA
10 (*e.g.* Cyna), and multiple barrier approaches to treatment reliability (*e.g.* Demotier *et*
11 *al.*; Eisenberg *et al.*⁴¹; Haas and Trussell⁵⁷). An illustration of an integrated approach
12 to evaluating plant reliability is provided by Cyna, who describes the methodology
13 developed and applied by the *Compagnie Generale des Eaux* (France) (Figure 7).
14 Following system definition and modelling (*via* reliability block diagrams), risks are
15 identified and classified using HAZOP. Risk consequences are subsequently
16 quantified *via* FMECA, allowing the computation of system availability (the
17 probability of the system to be found operative at a given time). Cyna describes how
18 the methodology was applied to a proposed post-chlorination system in *Neuilly-sur-*
19 *Marne* plant, arguing that its employment helped conceive a reliable system and
20 verified the adequacy of plant availability. The author concludes that reliability
21 analysis is an essential tool at ‘conception’, which allows the adjustment of project
22 design, and thus cost, to the level of reliability required, and, when associated with
23 maintenance procedures, can provide insurance of design quality.

24

25

26 **5. CONCLUSION**

1

2 Risk management for water utilities is fast becoming an explicitly-stated
3 paradigm, recognising the implicit approach performed over the last 150 years. With
4 increasing globalisation, outsourcing and increased regulation of the industry, tools
5 that allow system vulnerabilities to be identified before failures occur are essential. In
6 many ways, however, the industry is discovering risk analysis afresh and there is a
7 learning curve to climb in terms of the capabilities and limitations of these tools and
8 techniques. The international water sector has helpfully restated its overarching goal
9 reminding us that even in the face of rationalisation and economic pressure, public
10 health protection⁸ is the principal business of the water industry. Risk analysis has a
11 part to play in focussing effort in the right places, but should not be treated as a
12 panacea or substitute for managing risk and neither allowed to dictate the outcome of
13 decisions without recourse to the fundamental goal of the business. Flexibility of
14 approach is key to the successful application of these tools, as is their appropriate
15 selection within the organisational context and legal framework. For large multi-
16 utilities, one can expect high developed business risk capabilities, whereas for smaller
17 and single utilities, an approach based on accepted codes and standards may be more
18 suitable. Our analysis provide a comprehensive inventory of the current state-of-the-
19 art as a reference for developing a risk analysis strategy that is fit for purpose.

20

21 **ACKNOWLEDGEMENTS**

22

23 This work has been funded by the American Water Works Association Research
24 Foundation (AwwaRF project RFP2939), Yorkshire Water Services, the Canadian
25 Water Network and a consortium of international water utility companies and
26 organisations. The comments and views herein are the authors' alone. Brian

1 MacGillivray is co-funded on a UK Engineering and Physical Sciences Research
2 Council Doctoral Training Account.

3

4 **REFERENCES**

5

- 6 1. American Institute of Chemical Engineers, *Guidelines for Hazard Evaluation*
7 *Procedures, 2nd Edition*, American Institute of Chemical Engineers, New York,
8 1992, 64-67
- 9 2. Andersson, C. and Destouni, G., Risk-cost analysis in ground water contaminant
10 transport: the role of random spatial variability and sorption kinetics, *Ground*
11 *Water*, **39**(1), 35, 2001.
- 12 3. Andreu, J., Capilla, J. and Sanchis, E., AQUATOOL, a generalized decision-
13 support system for water resources planning and operational management, *J.*
14 *Hydrol.*, **177**, 269, 1996.
- 15 4. Anon., Retention risk assessment, *Incentive*, **175**(2), 68, 2001.
- 16 5. Ashbolt, N.J., Risk analysis of drinking water microbial contamination versus
17 disinfection by-products (DBPs), *Toxicology*, **198**, 255, 2004.
- 18 6. Asian Development Bank (ADB), *Handbook for the Economic Analysis of*
19 *Water Supply Projects*, ADB, 1999. (website:
20 http://www.adb.org/Documents/Handbooks/Water_Supply_Projects/default.asp)
- 21 7. Asian Development Bank (ADB), *Proceedings of the regional forum on*
22 *regulatory systems and networking of water utilities and regulatory bodies*,
23 ADB, 2001. (website:
24 http://www.adb.org/Documents/Conference/Water_Uilities/default.asp).

- 1 8. AWWA, EUREAU, WSAA and DVGW, *Bonn Workshop 2001 – Key principles*
2 *in establishing a framework for assuring the quality of drinking water: a*
3 *summary*, AWWA, Denver, CO., 2001.
- 4 9. Barney, S.M., Retaining our workforce, regaining our potential, *J. Healthcare*
5 *Manage.*, **47**(5), 291, 2002.
- 6 10. Barreix, A., Jenkins, G.P. and Marchesini, M., *Case 1. Restructuring the water*
7 *and sewer utility in Panama*, World Bank, 2003. (website:
8 http://130.15.74.22/publications/panama_water.pdf).
- 9 11. Beck, M.B., Applying systems analysis in managing the water environment:
10 towards a new agenda, *Wat. Sci. Tech.*, **36**(5), 1, 1997.
- 11 12. Berry, M.A., Burmeister, E. and McElroy, M.B., Sorting out risks using known
12 APT factors, *Financial Analysts J.*, **44**(2), 29, 1988.
- 13 13. Besner, M-C., Gauthier, V., Barbeau, B. and Millette, R., Understanding
14 distribution system water quality, *J. AWWA*, **93**(7), 101, 2001.
- 15 14. Black, F. and Scholes, M., The pricing of options and corporate liabilities, *J.*
16 *Politic. Econ.*, **81**(3), 637, 1973.
- 17 15. Boak, R.A. and Packman, M.J., A methodology for the assessment of risk of
18 *Cryptosporidium* contamination of groundwater, *Quarterly J. Engg. Geol.*
19 *Hydrogeol.*, **34**(2), 187, 2001.
- 20 16. Booth, R. and Rogers, J., Using GIS technology to manage infrastructure capital
21 assets, *J. AWWA*, **93**(11), 62, 2001.
- 22 17. Brammer, L.F. and Schulte, A.M., A joint US and UK approach to water supply
23 and distribution modelling, *J. IWEM*, **7**, 471, 1993.
- 24 18. Brueck, T., Facing the workforce reality: making more out of less, *J. AWWA*,
25 **94**(6), 34, 2002.

- 1 19. Buckland, R. and Fraser, P., Political and regulatory risk in water utilities: Beta
2 sensitivity in the United Kingdom, *Journal of Business Financing and*
3 *Accounting*, **28**(7/8), 877, 2001.
- 4 20. Bunn, D.W., Dyner, U. and Larsen, E.R., Modelling latent market power across
5 gas and electricity markets, *Syst. Dynam. Rev.*, **13**, 271, 1997.
- 6 21. Burchett, J.F. and Tummala, V.M.R., The application of risk management
7 process in capital investment decisions for EHV transmission line projects,
8 *Constr. Manage. Econ.*, **16**, 235, 1998.
- 9 22. Clark, T., Jeffrey, P. and Stephenson, T., Complex agendas for new technology
10 adoption in the UK water industry, *Technovation*, **20**, 247, 2000.
- 11 23. Clemons, E.K., Using scenario analysis to manage the strategic risks of
12 reengineering, *Sloan Manage. Rev.*, **36**(4), 61, 1995.
- 13 24. Codex Alimentarius, *Guidelines for the Application of the Hazard Analysis and*
14 *Critical Control Point (HACCP) System*, ALINORM 93 / 13A, Appendix 2,
15 WHO, Geneva, 1993.
- 16 25. Cole, J.A., Hawker, P.J., Lawson, J.D. and Montgomery, H.A.C., Pollution risks
17 and countermeasures for surface water intakes, *J. IWEM*, **2**, 603, 1988.
- 18 26. Colmer, G., Dunkley, M., Gray, K., Pugh, P. and Williamson, A., Estimating the
19 cost of new technology products, *Intl. J. Technol. Manage.*, **17**(7/8), 840, 1999.
- 20 27. Cowan, S., Competition in the water industry, *Oxford Rev. of Econ. Policy*,
21 **13**(1), 83, 1997.
- 22 28. Crowe, T.J., Fong, P.M., Bauman, T.A. and Zayas-Castro, J.L., Quantitative risk
23 level estimation of business process reengineering efforts, *Business Proc.*
24 *Manage. J.*, **8**(5), 490, 2002.
- 25 29. Cyna, B., Reliability analyses of water treatment plants, *Water Supply*
26 *(Amsterdam)*, **15**(2), 65, 1997.

- 1 30. Dabrowski, J.M., Peall, S.K.C., Van Niekerk, A., Reinecke, A.J., Day, J.A. and
2 Schulz, R., Predicting runoff-induced pesticide input in agricultural sub-
3 catchment surface waters: linking catchment variables and contamination, *Wat.*
4 *Res.*, **36**, 4975, 2002.
- 5 31. Dean, A., Carlisle, Y. and Baden-Fuller, C., Punctuated and continuous change:
6 the UK water industry, *Brit. J. Manage.*, **10**, S3, 1999.
- 7 32. Demotier, S., Odeh, K., Schon, W., Charles, P., Fotoohi, F. and Allieux, J-F.,
8 *Risk assessment for drinking water production process*, 2002. (website:
9 <http://www.hds.utc.fr/~tdenoeux/sime/publis/esrel2002.pdf>).
- 10 33. Denton, D.K., Keeping employees: the Federal Express approach, *S.A.M. Adv.*
11 *Manage. J.*, **57**(3), 10, 1992.
- 12 34. Dewettinck, T., Van Houtte, E., Geenens, D., Van Gege, K. and Verstraete, W.,
13 HACCP (Hazard Analysis and Critical Control Points) to guarantee safe water
14 reuse and drinking water production – a case study, *Water Science and*
15 *Technology*, **43**(12), 31, 2001.
- 16 35. Dickerson, A.P., Gibson, H.D. and Tsakalotos, E., Is attack the best form of
17 defence? A competing risk analysis of acquisition activity in the UK,
18 *Cambridge J. Econ.*, **27**(3), 337, 2003.
- 19 36. Downey, J.M., Risks of outsourcing – applying risk management techniques to
20 staffing methods, *Facilities*, **13**(9/10), 38, 1995.
- 21 37. Doyle G. and Grabinsky, M., Applying GIS to a water main corrosion study. *J.*
22 *AWWA*, **93**(5), 90, 2003.
- 23 38. Drohan, W.M. and O'Connor, K., Competitor analysis can give your association
24 the edge, *Association Management*, **50**(1), 103, 1998.
- 25 39. Egerton, A.J., *FMEA – water flowsheet*, Lectures in risk management for water
26 and wastewater engineers, Egerton Consulting Ltd., 2004.

- 1 40. Egerton, A.J., Minimising the risk of contamination in water treatment, Lecture
2 given at a Pipeline Industries Guild/Institute of Water Officers meeting, Bristol
3 Water, United Kingdom, 14th February, 2004. (website:
4 www.egertonconsulting.co.uk).
- 5 41. Eisenberg, D., Soller, J., Sakaji, R. and Olivieri, A., A methodology to evaluate
6 water and wastewater treatment plant reliability, *Wat. Sci. Technol.*, **43**(10), 91,
7 2001.
- 8 42. Elias, D., Allocating capital risk: Who should pay?, *Wat. Engg. Manage.*,
9 **148**(5), 61, 2001.
- 10 43. Fedra, K., Integrated risk assessment and management: overview and state of
11 the art, *J. Haz. Mat.*, **61**, 5, 1998.
- 12 44. Feijtel, T., Boeije, G., Matthies, M., Young, A., Morris, G., Gandolfi, C.,
13 Hansen, B., Fox, K., Matthijs, E., Koch, V., Schroder, R., Cassani, G.,
14 Schowanek, D., Rosenblom, J. and Holt, M., Development of a geography-
15 referenced regional exposure assessment tool for European rivers – GREAT-ER,
16 *J. Haz. Mat.*, **61**, 59, 1998.
- 17 45. Fewtrell L. and Bartram J., *Water quality: guidelines, standards and health –*
18 *Assessment of risk and risk management for water-related infectious disease*,
19 IWA Publishing, London, 2001.
- 20 46. Fisher, M.L., What is the right supply chain for your product?, *Harvard*
21 *Business Review*, **75**(2), 105, 1997.
- 22 47. Fitzpatrick, E.W., Assessing the worth of new technology, *J. Amer. Soc. of CLU*
23 *and ChFC*, **49**(4), 37, 1995.
- 24 48. Foran, J., Brosnan, T., Connor, M., Delfino, K., Depinto, J., Dickson, K.,
25 Humphrey, H., Novotny, V., Smith, R., Sobsey, M. and Stehman, S., A

- 1 framework for comprehensive, integrated, watershed monitoring in New York
2 City. *Environ. Monit. Assess.* **62**, 147, 2000.
- 3 49. Foster, J.A. and McDonald, A.T., Assessing pollution risks to water supply
4 intakes using geographic information systems (GIS), *Environ. Modelling and
5 Software*, **15**, 225, 2000.
- 6 50. Foster, M., Fell, R. and Spannagle, M., A method for assessing the relative
7 likelihood of failure of embankment dams by piping, *Can. Geotechn. J.* **37**(5),
8 1025, 2000.
- 9 51. Fuest, S., Berlekamp, J., Klein, M. and Matthies, M., Risk hazard mapping of
10 groundwater contamination using long-term monitoring data of shallow drinking
11 water wells, *J. Haz. Mat.*, **61**, 197, 1998.
- 12 52. Gale, P., Developments in microbiological risk assessment for drinking water, *J.
13 Appl. Microbiology*, **91**, 191, 2001.
- 14 53. Gray, R.S. and Powell, E., Risk management of major aqueducts, *J. IWEM*, **2**,
15 594, 1988.
- 16 54. Gregory, A., The usefulness of Beta in the investment-appraisal process,
17 *Financial Management*, **68**(1), 42, 1990.
- 18 55. Grimsey, D. and Lewis, M.K., Evaluating the risks of public private partnerships
19 for infrastructure projects, *Int. J. Proj. Manage.*, **20**, 107, 2002.
- 20 56. Gündüz, O., Soyupak, S. and Yurteri, Development of water quality
21 management strategies for the proposed Isikli Reservoir, *Wat. Sci. Technol.*,
22 **37**(2), 369, 1998.
- 23 57. Haas, C.N. and Trussell, R.R., Frameworks for assessing reliability of multiple,
24 independent barriers in potable water reuse, *Wat. Sci. Technol.*, **38**(6), 1, 1998.
- 25 58. Haas, C.N., Progress and data gaps in quantitative microbial risk assessment,
26 *Wat. Sci. Tech.*, **46**(11), 277, 2002.

- 1 59. Haas, C.N., Rose, J.B., Gerba, C.P., *Quantitative Microbial Risk Assessment*,
2 Wiley, NY, 1999.
- 3 60. Hagevik, S., What keeps 'em? *J. Environ. Hlth.*, **63**(6), 50, 2001.
- 4 61. Halfacree, S., Pollution risk management, *Issues in Environ. Sci. Technol.*, **9**, 37,
5 1998.
- 6 62. Hartmann, G.C. and Lakatos, A.I., Assessing technology risk – a case study,
7 *Res. Technol. Manage.*, **41**(2), 32, 1998.
- 8 63. Heikkilä, J. and Cordon, C., Outsourcing: a core or non-core strategic
9 management decision?, *Strategic Change*, **11**, 183, 2002.
- 10 64. Hellier, K., Hazard analysis and critical control points for water supplies, *Proc.*
11 *63rd Annual Water Industry Engineers and Operator's Conference*,
12 Warrnambool, 6-7 September, 2000.
- 13 65. Hern, R., Competition and access pricing in the UK water industry, *Utilities*
14 *Policy*, **10**, 117, 2001.
- 15 66. Hertz, D.B., Risk analysis in capital investment, *Harvard Business Review*,
16 **42**(1), 95, 1964.
- 17 67. Hrudey, S.E. and Leiss, W., Risk management and precaution – insights on the
18 cautious use of evidence, *Environ. Health Persp.*, **111**, 1577, 2003.
- 19 68. Hrudey, S.E., Limits to Science for Assessing and Managing Environmental
20 Health Risks, *Science, Truth and Justice*, Canadian Institute for the
21 Administration of Justice, Les Éditions Thémis. Faculté de Droit. Université de
22 Montréal, pp. 128-150, 2000.
- 23 69. Hunter, P.R., Waite, M., Ronchi, E., *Drinking Water and Infectious Disease:*
24 *Establishing the Links*, IWA Publishing, London, 2002.

- 1 70. IMPRESS Management, *IMPRESS Guidance*, Guidance for the analysis of
2 pressures and impacts in accordance with the water framework directive, Draft
3 5.2, European Commission, Brussels, 2002.
- 4 71. Jinno, K., Zongxue, X, Kawamura, A. and Tajiri, K., Risk assessment of a water
5 supply system during drought, *Wat. Resource Develop.*, **11**(2), 185, 1995.
- 6 72. Kaufman, M.M. and Wurtz, M., Small system maintenance management using
7 GIS, *J. AWWA*, **90**(8), 70, 1998.
- 8 73. Kent, N.A., Treece, D. and Davies, M., Asset management through risk
9 assessment for Welsh Water's water trunk mains, *Proc. ICE/CIWEM*
10 *Conference: Risk and reward in asset management delivery – who is best*
11 *prepared for the challenges ahead?*, 14th November, 2003, London, UK.
- 12 74. Khan, F.I. and Abbasi, S.A., Towards automation of HAZOP with a new tool
13 EXPERTOP, *Environ. Modelling and Software*, **15**, 67, 2000.
- 14 75. Kilpatrick, K. and Lapsley, I., "Trust us" – Regulators and the governance of
15 privatized utilities, *Public Money Manage.*, **16**(2), 39, 1996.
- 16 76. Laing, R.D., *Report of the Commission of Inquiry into matters relating to the*
17 *safety of the public drinking water in the City of North Battleford,*
18 *Saskatchewan.*, The Queen's Printer, Regina, Saskatchewan, March 28th, 2002.
19 (website: <http://www.northbattlefordwaterinquiry.ca>.)
- 20 77. Lantzy, R.J., Cichy, P.T. and Leitzinger, A.H., Use of geographical maps to
21 manage risk from groundwater contamination, *Journal of Hazardous Materials*,
22 **61**, 319, 1998.
- 23 78. Larsen, E.R. and Bunn, D.W., Deregulation in electricity: understanding
24 strategic and regulatory risk, *J. Oper. Res. Soc.*, **50**, 337, 1999.
- 25 79. Latiffe, R., Probabilistic risk analysis of large dams: its value and limits, *Intl.*
26 *Wat. Power and Dam Constr.*, **45**(3), 13, 1993.

- 1 80. Latinopoulos, P., Mylopoulos, N. and Mylopoulos, Y., Risk-based decision
2 analysis in the design of water supply projects, *Wat. Resources Manage.*, **11**,
3 263, 1997.
- 4 81. Li, S.G. and McLaughlin, D., A nonstationary spectral method for solving
5 stochastic groundwater problems – unconditional analysis, *Wat. Resources Res.*,
6 **27(7)**, 1589, 1991.
- 7 82. Lifton, G. and Smeaton, P., Asset risk management in Scottish Water, *Proc. of*
8 *the ICE/CIWEM Conference: Risk and reward in asset management delivery –*
9 *who is best prepared for the challenges ahead?*, 14th November, 2003, London,
10 UK.
- 11 83. Lindley, T.R. and Buchberger, S.G., Assessing intrusion susceptibility in
12 distribution systems, *J. AWWA*, **94(6)**, 66, 2002.
- 13 84. Liou, T-S. and Yeh, H-D., Conditional expectation for evaluation of risk
14 groundwater flow and solute transport: one-dimensional analysis, *J. Hydrol.*,
15 **199**, 378, 1997.
- 16 85. Littlechild, S.C., *Economic Regulation of Privatised Water Authorities*, London,
17 HMSO, 1986.
- 18 86. Lonsdale, C., Effectively managing vertical supply relationships: a risk
19 management model for outsourcing, *Supply Chain Manage.*, **4(4)**, 176, 1999.
- 20 87. Luehrman, T.A., What's it worth? A general manager's guide to valuation,
21 *Harvard Business Review*, **75(3)**, 132, 1997.
- 22 88. Lytton, L., Howe, S., Sage, R. and Greenaway, P., Groundwater abstraction
23 pollution risk assessment, *Wat. Sci. Technol.*, **47(9)**, 1, 2003.
- 24 89. Mailhot, A. and Villeneuve, J-P., Mean-value second-order uncertainty analysis
25 method: application to water quality modelling, *Advances in Wat. Resources*,
26 **26**, 491, 2003.

- 1 90. Masago, Y., Katayama, H., Hashimoto, A., Hirata, T. and Ohgaki, S.,
2 Assessment of risk of infection due to *Cryptosporidium parvum* in drinking
3 water, *Wat. Sci. Tech.*, **46**, 319, 2002.
- 4 91. Maxwell, S., Where are we headed? Ten key trends and developments in the
5 water industry, *J. AWWA*, **93**(4), 114, 2001.
- 6 92. McGaughey Jr., R.E., Synder, C.A. and Carr, H.H., Implementing information
7 technology for competitive advantage: risk management issues, *Information and*
8 *Manage.*, **26**, 273, 1994.
- 9 93. McIntyre, N.R., Wagener, T., Wheeler, H.S. and Chapra, S.C., Risk-based
10 modelling of surface water quality: a case study of the Charles River,
11 Massachusetts, *J. Hydrol.*, **274**, 225, 2003.
- 12 94. McNally, J.S., Retaining valued employees, *Pennsylvania CPA J.*, **71**(4), 24,
13 2001.
- 14 95. Medema, G.J., Hoogenboezem, W., van der Veer, A.J., Ketelaars, H.A.M.,
15 Hijnen, W.A.M. and Nobel, P.J., Quantitative risk assessment of
16 *Cryptosporidium* in surface water treatment, *Wat. Sci. Technol.*, **47**(3), 241,
17 2003.
- 18 96. Merabtene, T., Kawamura, A., Jinno, K. and Olsson, J., Risk assessment for
19 optimal drought management of an integrated water resources system using a
20 genetic algorithm, *Hydrological Processes*, **16**, 2189, 2002.
- 21 97. Modigliani and Miller, The cost of capital, corporation finance and the theory of
22 investment, *Amer. Econ. Rev.*, **48**(3), 261, 1958.
- 23 98. Morana, C. and Sawkins, J.W., Regulatory uncertainty and share price volatility:
24 the English and Welsh water industry's periodic price review, *J. Regul. Econ.*,
25 **17**(1), 87, 2000.

- 1 99. Mosca, R., Schenone, M. and Bonello, A.F., Risk analysis in the evaluation of
2 plant investments: the contribution of a non-deterministic approach, *Proj.*
3 *Manage. J.*, **32**(3), 4, 2001.
- 4 100. Mowday, R.T., Strategies for adapting to high rates of employee turnover,
5 *Human Resource Manage.*, **23**(4), 365, 1984.
- 6 101. Mullenger, J., Ryan, G., and Hearn, J., A water authority's experience with
7 HACCP, *Wat. Sci. Tech: Wat. Supply*, **2**(5/6), 149, 2002.
- 8 102. Myers, S.C., Interactions of corporate financing and investment decisions –
9 implications for capital budgeting, *J. Finance*, **29**(1), 1, 1974.
- 10 103. National Academy of Sciences, *Risk Assessment in the Federal Government:*
11 *Managing the Process*, National Academy Press, Washington, DC, 1983.
- 12 104. Newman, W.R., Hanna, M. and Maffei, M.J., Dealing with the uncertainties of
13 manufacturing: flexibility, buffers and integration, *Intl. J. Operations and*
14 *Production Manage.*, **13**(1), 19, 1993.
- 15 105. NHMRC, *Framework for Management of Drinking Water Quality*, NHMRC,
16 New Zealand, 2001.
- 17 106. NRDC, *What's on tap? Grading drinking water in US cities*, Natural Resources
18 Defense Council, Washington DC, 2003. (website:
19 <http://www2.nrdc.org/water/drinking/uscities/pdf.>).
- 20 107. NRWA, Security vulnerability self-assessment guide for small drinking water
21 systems, 2002. (website:
22 <http://www.health.ri.gov/environment/dwq/security/vulnerability.htm>).
- 23 108. O'Connor D.R., *Report of the Walkerton Inquiry. Part 1. The events of May*
24 *2000 and related issues*, The Attorney General of Ontario, Toronto, Canada,
25 2002.

- 1 109. O'Reilly, C.A., Chatman, J.A. and Caldwell, D., People and organizational
2 culture: A profile comparison approach to assessing person-organization fit,
3 *Academy of Manage. J.*, **34**(3), 487, 1991.
- 4 110. Ofwat, *Access codes for common carriage: guidance*, Ofwat, 2002. (website:
5 <http://www.ofwat.gov.uk>).
- 6 111. Osowski, S.L., Swick Jr, J.D., Carney, G.R., Pena, H.B., Danielson, J.E. and
7 Parrish, D.A., A watershed-based cumulative risk impact analysis:
8 Environmental vulnerability and impact criteria, *Environ. Monit. Assess.*, **66**,
9 159, 1999.
- 10 112. Ostfeld, A., Kogan, D. and Shamir, U., Reliability simulation of water
11 distribution systems – single and multiquality, *Urban Water*, **4**, 53, 2002.
- 12 113. Ostfeld, A., Reliability analysis of regional water distribution systems, *Urban*
13 *Water*, **3**, 253, 2001.
- 14 114. Parker, D., Performance, risk and strategy in privatised, regulated industries,
15 *Intl. J. Public Sector Manage.*, **16**(1), 75, 2003.
- 16 115. Parker, D., Reducing regulatory risk: the case for a new regulatory contract with
17 the privatized utilities, *Public Money Manage.*, **18**(4), 51, 1998.
- 18 116. Parmelee, M.A., Trends in outsourcing for water utilities, *J. AWWA*, **94**(9), 54,
19 2002.
- 20 117. Parr, N.M. and Cullen, N., Risk management and reservoir maintenance, *J.*
21 *IWEM*, **2**, 587, 1988.
- 22 118. Passarella, G., Vurro, M., D'Agostino, V., Guiliano, G. and Barcelona, M.J., A
23 probabilistic methodology to assess the risk of groundwater quality degradation,
24 *Environ. Monit. Assess.*, **79**, 57, 2001.
- 25 119. Payment, P., Richardson, L., Siemiatycki, J., Dewar, R., Edwardes, M. and
26 Franco, E., A randomized trial to evaluate the risk of gastrointestinal disease due

- 1 to consumption of drinking water meeting currently accepted microbial
2 standards, *Amer. J. Public Hlth.*, **81**(6), 703, 1991.
- 3 120. Phelps, R., Chan, C., Kapsalis, S.C., Does scenario planning affect
4 performance? Two exploratory studies, *J. Business Res.*, **51**, 223, 2001.
- 5 121. Pollard, S.J.T., Strutt, J.E., MacGillivray, B.H., Hamilton, P.D. and Hrudey,
6 S.E., Risk analysis and management in the water utility sector – a review of
7 drivers, tools and techniques, *Trans. IChemE, Part B: Proc. Safety Environ.*
8 **82**(B6): 453, 2004
- 9 122. Pollard, S.J.T., Yearsley, R., Reynard, N., Meadowcroft, I.C., Duarte-Davidson,
10 R. and Duerden, S., Current directions in the practice of environmental risk
11 assessment in the United Kingdom, *Environ. Sci. Technol.*, **36**(4): 530, 2002.
- 12 123. Portielje, R., Hvitved-Jacobsen, T. and Schaarup-Jensen, K., Risk analysis using
13 stochastic reliability methods applied to two cases of deterministic water quality
14 models, *Wat. Res.*, **34**(1), 153, 2000.
- 15 124. Prime Minister's Strategy Unit, *Risk: improving Government's capability to*
16 *handle risk and uncertainty*, The Strategy Unit, London, 2002. (website:
17 <http://www.number-10.gov.uk/SU/RISK/risk/home.html>).
- 18 125. Quélin, B. and Duhamel, F., Bringing together strategic outsourcing and
19 corporate strategy: outsourcing motives and risks, *Eur. Manage. J.*, **21**(5), 647,
20 2003.
- 21 126. Radovanovic, R. and Marlin, A., Critical water mains – the need for risk
22 analysis, *Water (Australia)*, **30** (2), 42, 2003.
- 23 127. Rajani, B.B. and Kleiner, Y., *WARP – Water Mains Renewal Planner*, National
24 Research Council Canada, 2001. (website: [http://irc.nrc-](http://irc.nrc-cnrc.gc.ca/fulltext/nrcc44680/)
25 [cnrc.gc.ca/fulltext/nrcc44680/](http://irc.nrc-cnrc.gc.ca/fulltext/nrcc44680/))

- 1 128. Ranasinghe, M., Private sector participation in infrastructure projects: a
2 methodology to analyse viability of BOT, *Constr. Manage. Econ.*, **17**, 613,
3 1999.
- 4 129. Rautman, C.A. and Istok, J.D., Probabilistic assessment of ground-water
5 contamination: 1. Geostatistical framework, *Ground Water*, **34**(5), 899, 1996.
- 6 130. Remenyi, D. and Heafield, A., Business process re-engineering: some aspects of
7 how to evaluate and manage the risk exposure, *Intl. J. Proj. Manage.*, **14**(6),
8 349, 1996.
- 9 131. Rizak, S., Cunliffe, D., Sinclair, M., Vulcano, R., Howard, J., Hrudey, S. and
10 Callan, P., Drinking water quality management: a holistic approach, *Wat. Sci.*
11 *Tech.*, **47**(9), 31, 2003.
- 12 132. Rogers, L.L., Dowla, F.U. and Johnson, V.M., Optimal field-scale groundwater
13 remediation using neural networks and the genetic algorithm, *Environ. Sci.*
14 *Technol.*, **29**, 1145, 1995.
- 15 133. Rothschild, W.E., Competitor analysis: the missing link in strategy, *The*
16 *McKinsey Quarterly*, **3**, 42, 1979.
- 17 134. Rothstein, E. and Kiyosaki, D., Development of a strategic plan: Portfolio
18 management for public utilities, *J. AWWA*, **95**(1), 52, 2003.
- 19 135. Saal, D.S. and Parker, D., Productivity and price performance in the privatized
20 water and sewerage companies of England and Wales, *Journal of Regul. Econ.*,
21 **20**(1), 61, 2001.
- 22 136. Sawkins, J.W., The development of competition in the English and Welsh water
23 and sewerage industry, *Fiscal Studies*, **22**(2), 189, 2001.
- 24 137. Sawkins, J.W., Yardstick competition in the English and Welsh water industry:
25 Fiction or reality?, *Utilities Policy*, **5**(1), 27, 1995.

- 1 138. Seidenstat, P., *Emerging competition in water and wastewater industries*.
2 Universities Council on Water Resources, 2000. (website:
3 www.ucowr.siu.edu/updates/pdf/V117_A2.pdf).
- 4 139. Seker, D.Z., Kadbasli, S. and Rudvan, B., Risk assessment of a dam-break using
5 GIS technology, *Wat. Sci. Technol.*, **48**(10), 89, 2003.
- 6 140. Sharpe, W.F., Capital asset prices: a theory of market equilibrium under
7 conditions of risk, *J. Finance*, **19**(3), 425, 1964.
- 8 141. Sheridan, J.E., Organizational culture and employee retention, *Academy*
9 *Manage. J.*, **35**(5), 1036, 1992.
- 10 142. Shimoda, T.A., Emergency preparedness and response, *J. AWWA*, **86**, 84, 1994.
- 11 143. Shleifer, A., A theory of yardstick competition, *Rand J. Econ.*, **16**(3), 319, 1985.
- 12 144. Sigler, K.J., Challenges of employee retention, *Manage. Res. News*, **22**(10), 1,
13 1999.
- 14 145. Singh, H. and Harianto, F., Management-board relationships, takeover risk, and
15 the adoption of golden parachutes, *Academy Manage. J.*, **32**(1), 7, 1989.
- 16 146. Sivertun, A. and Prange, L., Non-point source critical area analysis in the
17 Gisselö watershed using GIS, *Environ. Modelling and Software*, **18**, 887, 2003.
- 18 147. SNL news release, *Sandia develops program to assess water infrastructure*
19 *vulnerabilities*, October 3rd, 2001. (website:
20 <http://www.sandia.gov/media/NewsRel/NR2001/watinftr.htm>).
- 21 148. Songer, A.D., Diekmann, J. and Pecsok, R.S., Risk analysis for revenue
22 dependent infrastructure projects, *Constr. Manage. Econ.*, **15**, 377, 1997.
- 23 149. Stahl, G.R. and Elliott, J.C., ‘New generation’ computer models for risk-based
24 planning and management, *Water Supply (Australia)*, **17**(3/4), 289, 1999.

- 1 150. Stevens, I.M. and Lloyd, R.I., *Water resources: Sustainable optimisation and*
2 *security of supply, a proven example*, A paper presented to the 2004 Water
3 sources conference and exposition, Jan 11-14th, 2004, Austin, Texas.
- 4 151. Strutt, J.E., *Reliability data and sources*, Lectures in risk management for water
5 and wastewater engineers, Cranfield University, Cranfield, UK, 2004.
- 6 152. Sweeney, M.W., Geographic information systems, *Wat. Environ. Res.*, **71**(5),
7 551, 1999.
- 8 153. Ta, C.T., A probability model for burst risk studies of water mains, *Wat. Sci.*
9 *Technol.: Water Supply*, **2**(4), 29, 2001.
- 10 154. Tanyimboh, T.T., Availability of water in distribution systems, *Proc. Decision*
11 *Support in the Water Industry Under Conditions of Uncertainty, ACTUI2004.*
12 24-25th March, 2004, Exeter, UK.
- 13 155. Tebutt, R.J., Guy, J.A., Gochin, R.J. and Lester, J.N., Requirements of a capital
14 investment appraisal technique for the water industry in England and Wales,
15 *Eur. Wat. Manage.*, **4**(3), 47, 2001.
- 16 156. Teunis, P.F.M., Medema, G.J, Kruidenier, L. and Havelaar, A.H., Assessment of
17 the risk of infection by *Cryptosporidium* or *Giardia* in drinking water from a
18 surface water source, *Wat. Res.*, **31**(6), 1333, 1997.
- 19 157. Thomas, H., Risk analysis and the formulation of acquisition / diversification
20 strategies, *Long Range Planning* **16**(2), 28, 1983.
- 21 158. Thompson, R., Secrets to keeping good employees, *Business Credit*, **102**(1), 68,
22 2000.
- 23 159. UK Offshore Oil Operators Association (UKOOA), *Industry guidelines on a*
24 *framework for risk related decision support*, UKOOA, London, 1999.
- 25 160. UKWIR, *Managing microbial and chemical risks from source to tap*, Report
26 03/DW/02/31, UK Water Industry Research Limited, London, 2003.

- 1 161. Umweltbundesamt, Water safety conference abstracts, Scholl, O. and Chorus, I.,
2 Eds., Berlin, 28-30th April 2003.
- 3 162. US Department of Energy (USDOE), *Example process hazard analysis of a*
4 *department of energy water chlorination process*, USDOE, Washington DC,
5 1993. (website: http://tis-hq.eh.doe.gov/chem_safety/haz_analysis.html)
- 6 163. US General Accounting Office (USGAO), *Water infrastructure: Comprehensive*
7 *asset management has potential to help utilities better identify needs and plan*
8 *future investments*, USGAO, 2004. (website:
9 <http://www.gao.gov/new.items/d04461.pdf>).
- 10 164. Verro, R., Calliera, M., Maffioli, G., Auteri, D., Sala, S., Finizio, A. and Vighi,
11 M., GIS-based system for surface water risk assessment of agricultural
12 chemicals. 1. Methodological approach, *Environ. Sci. Technol.*, **36**, 1532, 2002.
- 13 165. Wang, J., Yuan, X., Zhang, Y. and Zhang, Y., A reliability and risk analysis
14 system for multipurpose reservoir operation, *Environ. Fluid Mech.*, **3**, 289,
15 2003.
- 16 166. Westerhoff, G.P, Pathways to higher performance, *J. AWWA*, **95**(7), 50-57,
17 2003.
- 18 167. WHO, *Guidelines for drinking water quality, 3rd Edition* (draft), WHO, 2003.
19 (website: http://www.who.int/water_sanitation_health/dwq/guidelines3rd/en/).
- 20 168. WHO, *Water safety plans (revised draft)*, Report publication
21 WHO/SDE/WSH/02.09, World Health Organisation, 2002.
- 22 169. Wickham, J.D. and Wade, T.G., Watershed level risk assessment of nitrogen
23 and phosphorus export, *Computers and Electronics in Agriculture*, **37**, 15, 2002.
- 24 170. Wildemann, H., Justification on strategic planning for new technologies, *Human*
25 *Syst. Manage.*, **6**, 253, 1986.

- 1 171. Wingle, W.L., Poeter, E.P. and McKenna, S.A., UNCERT: geostatistics,
2 uncertainty analysis and visualization software applied to groundwater flow and
3 contaminant transport modeling, *Computers and Geosciences*, **25**, 365, 1999.
- 4 172. World Bank, *Toolkits for private participation in water and sanitation*, World
5 Bank, 1997. (website:
6 <http://www.worldbank.org/html/fpd/water/wstoolkits/index.html>).
- 7 173. Ye, S. and Tiong, R.L.K., NPV-at-risk method in infrastructure project
8 investment valuation, *J. Constr. Engg. Manage.*, **126**(3), 227, 2000.
- 9 174. Zongxue, X., Jinno, K., Kawamura, A., Takesaki, S. and Ito, K., Performance
10 risk analysis for Fukuoka water supply system, *Wat. Resources Manage.*, **12**, 13,
11 1998.
- 12 175. Zoppou, C., Review of urban storm water models, *Environ. Modelling and
13 Software*, **16**, 195, 2001.
- 14 176. Zsidisin, G.A., Panelli, A. and Upton, R., Purchasing organization involvement
15 in risk assessments, contingency plans, and risk management: an exploratory
16 study, *Supply Chain Manage.*, **5**(4), 187, 2000.

17
18
19
20
21
22
23
24
25
26
27
28

1
2
3
4
5
6
7
8
9
10
11
12
13
14
15
16
17
18
19
20
21
22
23
24
25
26

Figure Captions

Figure 1. Decision Framework for the Offshore Oil Industry (UK Oil Operators Association¹⁵⁹ with permission).

Figure 2. The risk hierarchy (adapted from Prime Minister’s Strategy Unit¹²⁴).

Figure 3. Technology risk algorithm (Hartmann and Lakatos⁶²).

Figure 4. Illustrative fault tree for turbidity non-compliance (Demotier *et al.*³¹).

Figure 5. Reliability block diagrams (Cyna²⁹).

Figure 6. Risk-based workforce planning (after Pollard *et al.*¹²²).

Figure 7. Methodology for reliability analysis of a water treatment plant (Cyna²⁹).

1

2

3

4

5

6

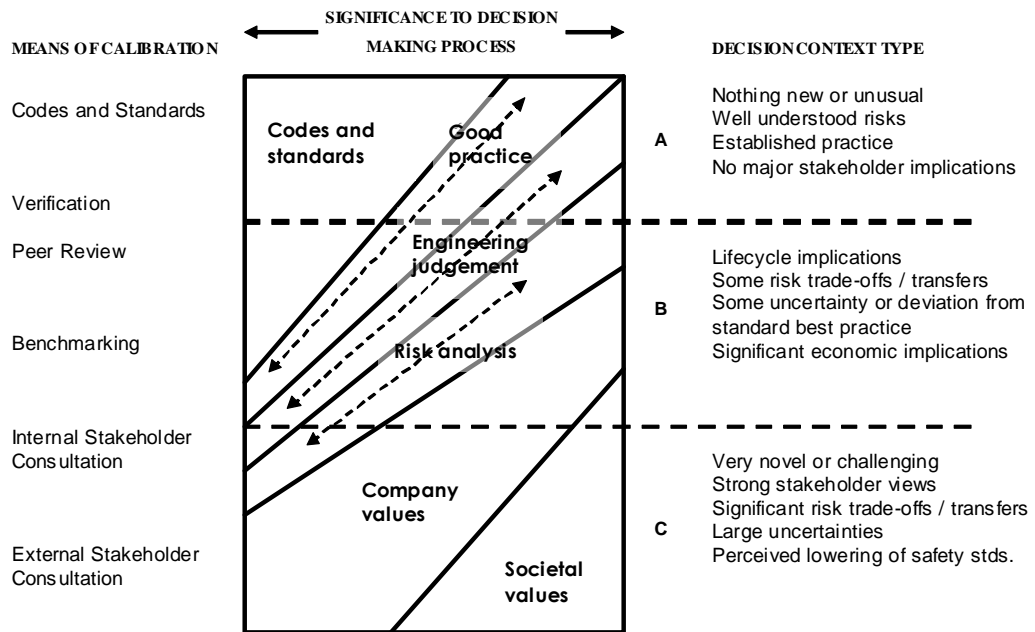

1
2
3
4
5
6
7
8
9
10

Figure 1. Decision Framework for the Offshore Oil Industry (UK Oil Operators Association¹⁵⁹ with permission).

1
2



3
4

5 *Figure 2. The risk hierarchy (adapted from Prime Minister's Strategy Unit¹²⁴).*

6

7

8

9

10

11

12

13

14

15

16

17

18

19

20

21

22

23

24

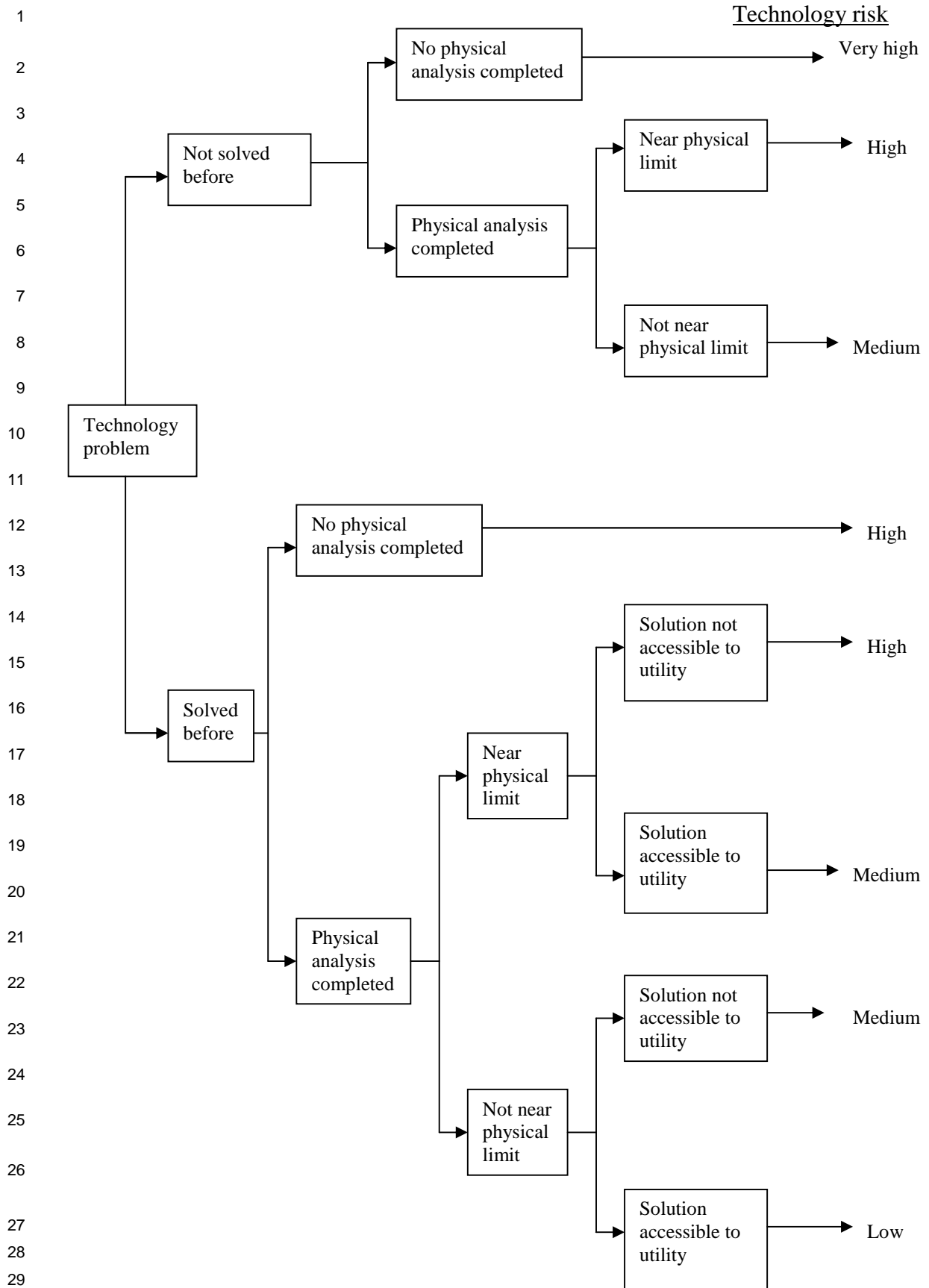
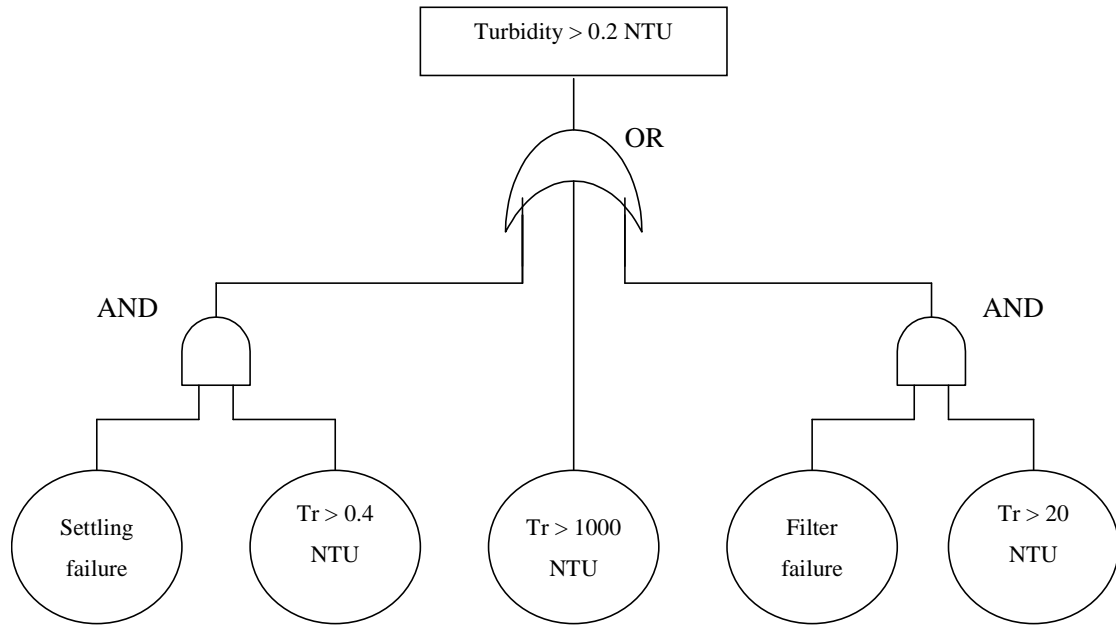

Figure 3. Technology risk algorithm (Hartmann and Lakatos⁶² with permission).

1



2

3 Tr = resource turbidity

4 The probability of the top-event may be calculated if the probabilities of the sub-events are known or
5 estimable.

6

7 *Figure 4.* Illustrative fault tree for turbidity non-compliance (after Demotier *et al.*³¹).

8

9

10

11

12

13

14

15

16

17

18

19

1
2
3
4
5
6
7
8
9
10
11
12
13
14
15
16
17
18
19
20
21
22
23
24
25
26
27
28
29
30
31
32
33
34
35
36
37
38
39
40
41
42
43
44
45
46
47
48
49

a) Series diagram – here, the system / process is working if A1 and A2 are working

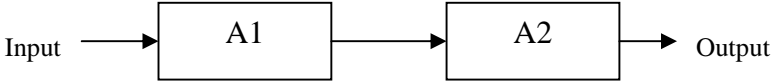

b) Parallel diagram – here, the system / process is working if A1 or A2 are working

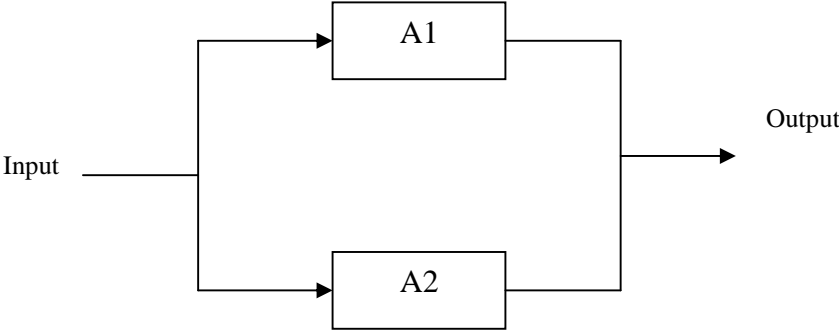

c) Redundancy diagram – here, the system / process is working if at least r elements among n are working

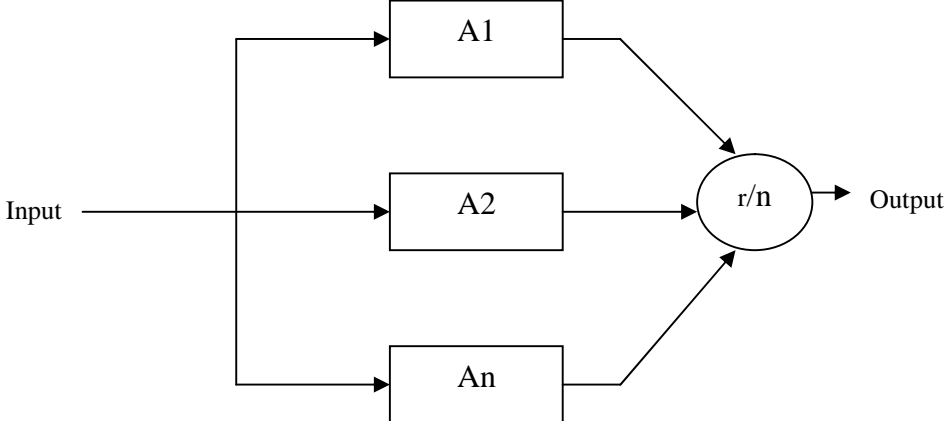
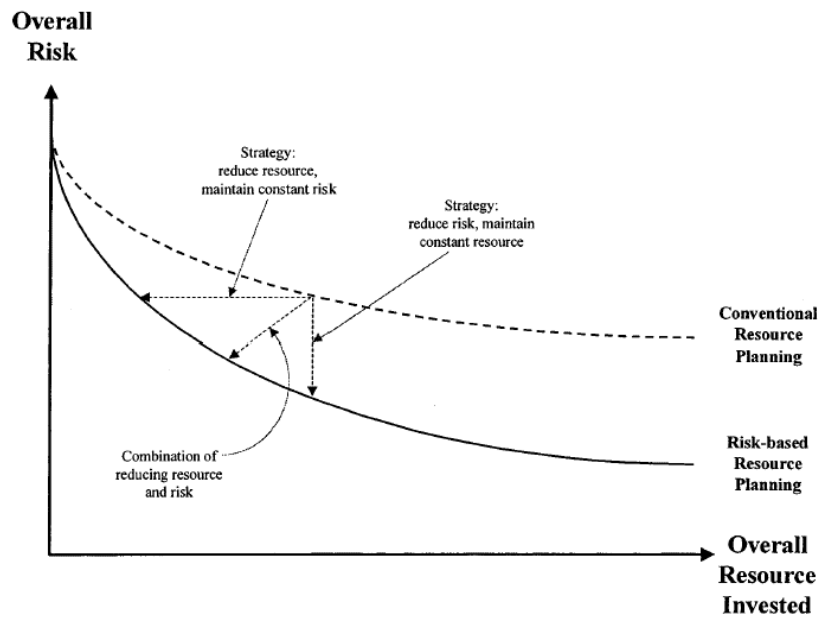

Figure 5. Reliability block diagrams (after Cyna²⁹).

1



2

3

4

5

Figure 6. Risk-based workforce planning (after Pollard *et al.*¹²²).

6

7

8

9

10

11

12

13

14

15

16

17

18

19

20

21

22

23

24

25

26

27

28

29

30

1
2
3
4
5
6
7
8
9
10
11
12
13
14
15
16
17
18
19
20
21
22
23
24
25
26
27
28
29
30
31
32
33
34
35
36
37
38
39
40
41
42

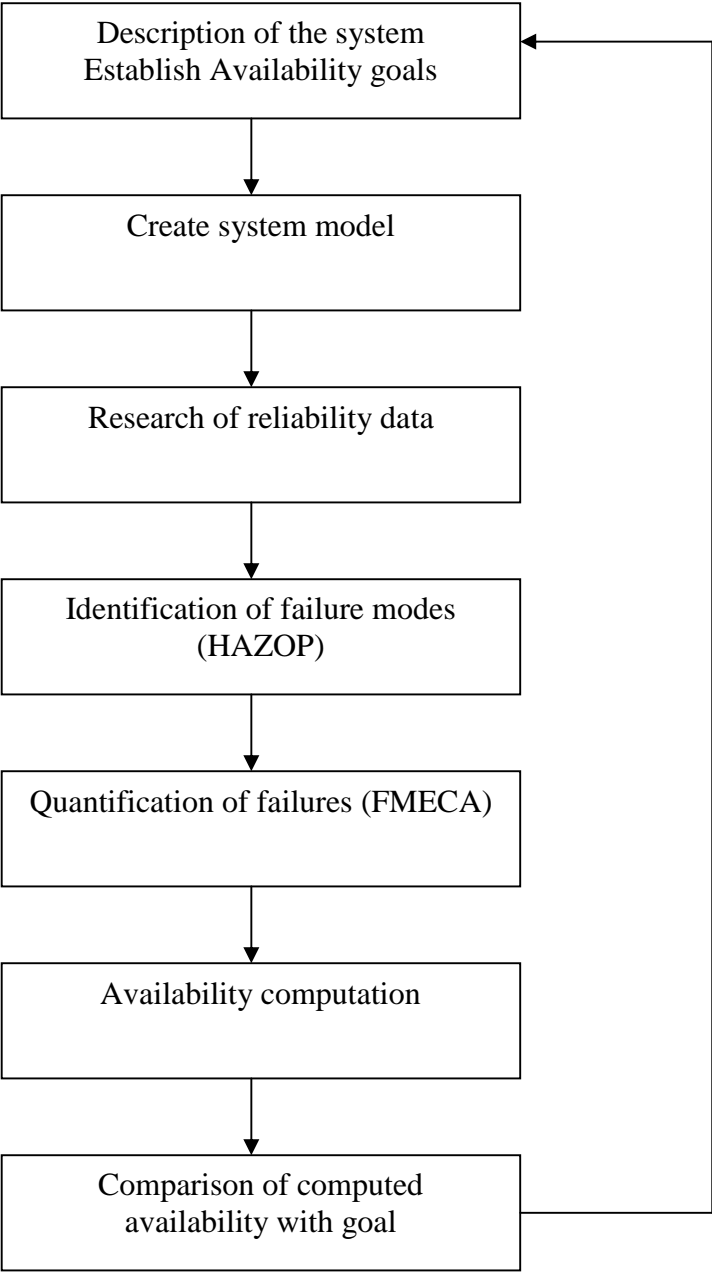

Figure 7. Methodology for reliability analysis of a water treatment plant (after Cyna²⁹).

Table 1. Strategic risk portfolio.

Context	Tool / Technique	Application	Reference
Regulatory risk	Ex-post modelling	Interpreting / evaluating the relationship between stock risk and regulatory events	Buckland and Fraser, ¹⁹ Morana and Sawkins. ⁹⁸
	Ex-ante modelling	Modelling evolution of regulatory environment	Larssen and Bunn, ⁷⁸ Bunn <i>et al.</i> ²⁰
Competition risks			
1) Comparative	Competitor analysis	Reducing price review uncertainty (and conventional benefits)	Drohan and O' Connor, ³⁸ Rothschild. ¹³³
2) Capital market	Screening	Tracking take-over risk	
	Investment analysis	Evaluating take-over opportunity	Thomas. ¹⁵⁷
3) For the market	Investment analysis	Evaluating joint venture	Ranasinghe, ¹²⁸ Grimsey and Lewis. ⁵⁵
4) Product market	Competitor identification / analysis	Minimising competitive threats	Rothschild, ¹³³ Drohan and O' Connor. ³⁸
	Investment analysis	Evaluating <i>de facto</i> take-over	
BPR risks	Scenario planning	Exploring potential BPR outcomes	Clemons. ²³
	Quantitative 'risk of failure'	Evaluating success likelihood of BPR efforts	Crowe <i>et al.</i> ²⁸
	Risk matrix	Appraising and comparing risks of BPR strategies	Remeyi and Heafield. ¹³⁰
1) New technology	Risk matrix	Appraising and comparing risks of new technology projects	McGaughey <i>et al.</i> ⁹²
	Risk algorithm	Characterising risk of new technology 'problems'	Hartmann and Lakatos. ⁶²
	Checklist	Minimising risk of new technology introduction	Hartmann and Lakatos. ⁶²
	Profile	Guiding strategic technology planning	Wildemann. ¹⁷⁰
Outsourcing	Outsourcing decision models	Evaluating core competencies and appraising market opportunities for outsourcing candidates	Quélin and Duhamel, ¹²⁵ Lonsdale. ⁸⁶
	Scenario planning	Exploring 'what-if' scenarios	Zsidisin <i>et al.</i> ¹⁷⁶
Employee retention	OCP	Evaluating 'cultural fit' of prospective employees	Sheridan, ¹⁴¹ O'Reilly <i>et al.</i> ¹⁰⁹
	Early warning system	Identification of 'at-risk' employee groups	McNally. ⁹⁴
	Gap analysis	To assess employee development and benefit schemes	
	Checklist	Informal assessment of retention risk	Anon. ⁴
Investment analysis			
1) Assets-in-place	NPV / IRR	Valuation of an ongoing business or some part of one	Barriex <i>et al.</i> , ¹⁰ Mosca <i>et al.</i> , ⁹⁹ ADB, ⁶ Burchett and Tummala, ²¹ Luehrman, ⁸⁷ Thomas. ¹⁵⁷
	Strategic portfolio planning	Creating a balanced utility investment portfolio	Rothstein and Kiyosaki. ¹³⁴
2) Opportunities	Option pricing theory	Valuation of possible future operations	Luehrman, ⁸⁷ Black and Scholes. ¹⁴
3) Joint Ventures	NPV / IRR	Valuation of prospective partnerships, strategic alliances	Grimsey and Lewis, ⁵⁵ Ranasinghe, ¹²⁸ Luehrman. ⁸⁷

Table 2. BPR risk matrix (after Remenyi and Heafield¹³⁰).

<i>Indicate the 10 most relevant factors</i>	
FACTORS	FACTORS
BUSINESS RISKS	CORPORATE CULTURE
Change to business scope (<i>e.g.</i> from diversifying)	Staff attitude to technology
Change to market structures	Staff attitude to changes
Change of regulatory relationship	Staff attitude to senior managers
Change of supplier relationship	Managerial style
Impact on (potential) ‘competitors’	Positive shared vision
FINANCIAL RISKS	TECHNOLOGY
Funded from current cash flow	Size of project
Funded from new equity	Structuredness of project
Funded from long term debt	Complexity of technology
Funded from short term debt	Complexity of application
	Novelty of technology
CORPORATE STRUCTURE	Novelty of application
Bureaucratic structure	Impact on technical infrastructure
Outsourcing utilisation	
Flexibility of job positions	HUMAN
	Skills base

Table 3. Programme level risk portfolio.

<i>Context</i>	<i>Tool / Technique</i>	<i>Application</i>	<i>Reference</i>
Asset management	Risk ranking	Prioritisation of remedial work on infrastructure assets	Kent <i>et al.</i> , ⁷³ Radovanovic and Marlin, ¹²⁶ Foster <i>et al.</i> ⁵⁰
	FMECA	'Source to tap' risk identification and prioritisation	Lifton and Smeaton. ⁸²
	Logic models	Evaluating structural failure modes	Gray and Powell, ⁵³ Parr and Cullen. ¹¹⁷
	GIS risk tracking	Infrastructure risk-tracking, visualisation and communication	Kaufman and Wurtz. ⁷²
	GIS spatial analysis	Risk-mapping of infrastructure	Doyle and Grabinski, ³⁷ Ta. ¹⁵³
	GIS risk simulation	Evaluating degradation risk	Lindley and Buchberger, ⁸³ Besner <i>et al.</i> ¹³
Catchment management	Risk ranking	Prioritisation of monitoring strategies	Dabrowski <i>et al.</i> , ³⁰ Verro <i>et al.</i> , ¹⁶⁴ Boak and Packman, ¹⁵ Feijtel <i>et al.</i> ⁴⁴
	GIS risk mapping	Mapping areas of catchment critical to water quality	Lytton <i>et al.</i> , ⁸⁸ Sivertun and Prange, ¹⁴⁶ Wickham and Wade, ¹⁶⁹ Foster and McDonald, ⁴⁹ Osowski <i>et al.</i> , ¹¹¹ Fuest <i>et al.</i> , ⁵¹ Lantzy. ⁷⁷
	Contaminant flow / transport modelling	Projecting degradation patterns / assessing risk of water quality violation	Anderson and Destouni, ² Gündüz <i>et al.</i> , ⁵⁶ Halfacree, ⁶¹ Liou and Yeh, ⁸⁴ Cole <i>et al.</i> ²⁵
	Kriging	Projecting degradation patterns with limited sample data (<i>e.g.</i> groundwater)	Passarella <i>et al.</i> , ¹¹⁸ Wingle <i>et al.</i> , ¹⁷¹ Rautman and Istok. ¹²⁹
	GIS risk simulation	Quantified risk mapping over space <i>and</i> time	Dabrowski <i>et al.</i> , ³⁰ Verro <i>et al.</i> , ¹⁶⁴ Feijtel <i>et al.</i> ⁴⁴
Network analysis	Network reliability modelling	a) Assess susceptibility to supply-demand scenarios; b) aid development of supply strategies and policies; c) assist design of distribution networks; and d) inform the need for capital expenditure.	Stevens and Lloyd, ¹⁵⁰ Lifton and Smeaton, ⁸² Wang <i>et al.</i> , ¹⁶⁵ Merabtene <i>et al.</i> , ⁹⁶ Ostfeld, ¹¹³ Stahl and Elliot, ¹⁴⁹ Zongxue <i>et al.</i> , ¹⁷⁴ Andreu <i>et al.</i> , ³ Jinno <i>et al.</i> ⁷¹
Vulnerability assessment	RAM-W	To assess system vulnerabilities and develop measures to reduce risks of attack.	SNL news release. ¹⁴⁷
	Questionnaire-based self assessment	As above	NRWA. ¹⁰⁷

Table 4. Component FMEA for chlorine cylinder and outlet valve (Egerton³⁹ with permission of Egerton Consulting Ltd.).

Failure mode	Failure effect on process	Failure effect on system	Methods of Detection	Comments
Fail to open / Reduced output / No output	Loss of adequate chlorination	Non-potable water will leave plant	Changeover should detect loss of supply	System failure would require combination of loss of flow and failure of changeover
Fail to close	None – changeover should transfer to standby cylinders	None	None	
Excess output	Excess chlorination	Possible taste and odour complaints. No serious consequences	Changeover should detect excess chlorine flow	
Outside specification (wrong or contaminated gas)	Outside specification (wrong or contaminated gas)	Non-potable water will leave plant. POTENTIAL FOR MAJOR SAFETY HAZARD	QA checks on delivery. Low chlorine residual readings and alarm	

Table 5. Operational level risk portfolio.

Context	Tool / Technique	Application	Reference
Compliance risk	Risk ranking	Prioritisation of plant contamination risks	Egerton. ⁴⁰
	QMRA	Assessing public health risk from microbial source contamination	Medema <i>et al.</i> , ⁹⁵ Teunis <i>et al.</i> ¹⁵⁶
	End-of-pipe compliance models	Assessing risk of exceeding water quality standards	Demotier <i>et al.</i> , ³ Trussell. ⁵⁷
	GIS simulation	Assessing risk of distribution system water quality degradation	Lindley and Buch <i>et al.</i> ¹³
Reliability analysis	HACCP	Identifying 'critical control points'	Mullenger <i>et al.</i> , <i>al.</i> , ³⁴ Hellier. ⁶⁴
	HAZOP	Evaluating deviations from design intent	US Department o and Abassi. ⁷⁴
	FMECA	Evaluating component failures	Lifton and Smea
	Logic modelling	Modelling process risk interactions	Demotier <i>et al.</i> , ³
	Multiple barrier approach	Assessing the reliability of multiple barrier treatment processes	Demotier <i>et al.</i> , ³ Haas and Trussel