

Christof Külske · Frank Redig

Loss without recovery of Gibbsianness during diffusion of continuous spins

Received: 19 September 2004 / Revised version: 3 June 2005 /
Published online: 12 September 2005 – © Springer-Verlag 2005

Abstract. We consider a specific continuous-spin Gibbs distribution $\mu_{t=0}$ for a double-well potential that allows for ferromagnetic ordering. We study the time-evolution of this initial measure under independent diffusions.

For ‘high temperature’ initial measures we prove that the time-evolved measure μ_t is Gibbsian for all t . For ‘low temperature’ initial measures we prove that μ_t stays Gibbsian for small enough times t , but loses its Gibbsian character for large enough t . In contrast to the analogous situation for discrete-spin Gibbs measures, there is no recovery of the Gibbs property for large t in the presence of a non-vanishing external magnetic field. All of our results hold for any dimension $d \geq 2$. This example suggests more generally that time-evolved continuous-spin models tend to be non-Gibbsian more easily than their discrete-spin counterparts.

1. Introduction

In a recent paper [8] it was discovered that a stochastic spin-flip time-evolution of a low-temperature Ising Gibbs-measure $\mu_{t=0}$ on $\{-1, 1\}^{\mathbb{Z}^d}$ at time $t = 0$ can lead to a non-Gibbsian measure μ_t on $\{-1, 1\}^{\mathbb{Z}^d}$ at time $t > 0$. The authors of [8] investigated a high-temperature Glauber dynamics applied to an initial low-temperature measure. They proved that for small times the time-evolved measure is always Gibbsian. For vanishing external magnetic field the time-evolved measure μ_t is non-Gibbsian for large enough t . For a non-vanishing external magnetic field there can be even an in- and out of Gibbsianness. This means that, either for small enough times or for large enough times the time-evolved measure μ_t is always Gibbsian, while for intermediate times the time-evolved measure is not a Gibbsian measure. See also [13] for a proof of propagation of Gibbsianness under more general stochastic dynamics for sufficiently small times.

In a different line of research going back to Deuschel [6] and put forward by Roelly, Zessin and coauthors [1, 14], the connection between interacting diffusions, indexed by the sites on the lattice \mathbb{Z}^d and Gibbs measures is investigated.

C. Külske: University of Groningen, Department of Mathematics and Computing Sciences, Blauwborgje 3, 9747 AC Groningen, The Netherlands.
e-mail: kuelske@math.rug.nl, <http://www.math.rug.nl/~kuelske/>

F. Redig: Mathematisch Instituut Universiteit Leiden, Snellius, Niels Bohrweg 1, 2333 CA Leiden, The Netherlands.
e-mail: redig@math.leidenuniv.nl, <http://www.math.leidenuniv.nl/~redig/>

Research carried out at EURANDOM and supported by Deutsche Forschungsgemeinschaft

In this context one asks whether the resulting measure on the path space of continuous functions from time to the infinite volume spin configurations can be interpreted as a Gibbs measure in a suitable sense. Moreover, also the Gibbsian character of the fixed-time projections μ_t is studied when the initial law is a continuous-spin Gibbs measure on $\mathbb{R}^{\mathbb{Z}^d}$. Since it is generally known that projections of Gibbs measures need not be Gibbs this question needs an independent investigation. For the latter question [4] announced a proof (full proof to be given in [5]) of the following ‘propagation of Gibbsianness for continuous spins under continuous time dynamics’: Suppose that the initial measure obeys a ‘strong Dobrushin uniqueness condition’. Then, either for small times t or weak interactions of the dynamics the time-evolved measure μ_t is again a continuous-spin Gibbs measure for an absolutely summable interaction. Let us point out however that their definition of Dobrushin uniqueness using the sup-norm is very restrictive in the case of unbounded variables. In particular it does not incorporate Gaussian fields that are not independent over the sites since these clearly have unbounded (quadratic) interactions.

The purpose of this paper is the study of the time evolution of a continuous-spin initial measure which is a Gibbs measure for a Hamiltonian with a quadratic nearest neighbor interaction and an a priori single-site double-well potential that has a specific form. This Hamiltonian has two phases of a ferromagnetic type at low temperatures. The specific choice of the Hamiltonian is made in order to obtain an elegant analysis of the problem. In particular we do not have to rely on cluster expansion techniques since we can use a precise correspondence between the continuous-spin model and a discrete-spin model which can be analyzed by monotonicity arguments. From our analysis it will be clear however that the phenomena which are present in this model are generic and not dependent on the specific choice of the single-site double-well potential. In particular with expansion techniques (cf. [11]) one could consider a cut-off version of this potential in order to deal with compact continuous spins. More precisely, the unboundedness of the spins is not essential for the transition Gibbs-non-Gibbs, but we believe it is responsible for the fact that there is no reentrance in the Gibbsian class.

In order to state our main result let us introduce the model.

1.1. The Gibbs distribution at time $t = 0$

Our model is given in terms of the formal infinite-volume Hamiltonian

$$H_{q,\rho^2,h}(\sigma) = \frac{q}{2} \sum_{\substack{\{x,y\} \\ d(x,y)=1}} (\sigma_x - \sigma_y)^2 + \sum_x V_{\rho^2}(\sigma_x) - qh \sum_x \sigma_x \quad (1)$$

for a spin-configuration $\sigma = (\sigma_x)_{x \in \mathbb{Z}^d}$ in the state space $\mathbb{R}^{\mathbb{Z}^d}$. Here we choose the single-site potential to be of the specific form

$$V_{\rho^2}(\sigma_x) = \frac{\sigma_x^2}{2\rho^2} - \log \cosh\left(\frac{\sigma_x}{\rho^2}\right) = -\log\left(\sum_{\tau_x=\pm 1} e^{-\frac{(\sigma_x-\tau_x)^2}{2\rho^2}}\right) + \text{Const} \quad (2)$$

The specifications in finite volume Λ are given in the standard way by restricting this Hamiltonian to terms that depend on Λ and writing the corresponding exponential factors w.r.t. to the Lebesgue-measure.

It is the specific choice of the potential that will simplify the analysis a lot. Note first of all, it is a simple exercise to verify that this potential has two different quadratic symmetric absolute minima if $\rho^2 < 1$. For $\rho^2 \geq 1$ the potential does not have a double well structure and hence it is not surprising that in that case the Gibbs measure is in fact unique, for all q .

The regime for which one could hope for ferromagnetic order is then for small ρ^2 and large couplings q . Indeed, we have the following result.

Theorem 1.1. *Let $h = 0$.*

(i) *Suppose that*

$$q^{-1} < \beta_d^{-1} - 2d\rho^2 \tag{3}$$

Then there exist different translation-invariant Gibbs measures μ^+ and μ^- . Moreover we have $\mu^+ > \mu^-$ stochastically.

Here β_d denotes the inverse critical temperature of the usual ferromagnetic nearest neighbor Ising model in dimension d with Hamiltonian $\beta \sum_{d(x,y)=1}^{\{x,y\}} \tau_x \tau_y$ and Ising variables $\tau_x = \pm 1$.

(ii) *Suppose that*

$$q^{-1} > 2d(1 - \rho^2) \tag{4}$$

Then the Gibbs measure is unique in the class of measures μ with $\sup_{x \in \mathbb{Z}^d} \mu(e^{\varepsilon|\sigma_x|}) < \infty$ for some $\varepsilon > 0$.

In the case (i) the state μ^+ (resp. μ^-) concentrates on configurations that live around the positive (resp. negative) wells of the potential. We will give a more detailed description below. For a brief reminder on stochastic domination, see the beginning of Section 2.2.

1.2. The dynamics

For the sake of concreteness let us just give our result on the time-evolution in the introduction only for the Ornstein-Uhlenbeck semigroup, applied site-wise independently to the spins of the lattice.

The Ornstein-Uhlenbeck process at a single site x is defined as the solution to the stochastic integral equation

$$d\sigma_x(t) = -\frac{1}{2}\sigma_x(t) + \rho_\infty dB_x(t) \tag{5}$$

where $\rho_\infty > 0$ is a parameter and $B_x(t)$ are Brownian motions that are independent over the sites. The solution with initial condition $\sigma_x(0) = \sigma_x$ is given by

$$\sigma_x(t) = e^{-\frac{t}{2}}\sigma_x + \rho_\infty e^{-\frac{t}{2}} \int_0^t e^{\frac{s}{2}} dB_x(s) \tag{6}$$

This implies that the single-site transition kernels giving the probabilities to see a spin value η_x at time $t > 0$ when one starts from a spin-value σ_x at time $t = 0$ are given by the Gaussian expression

$$p_t(\sigma_x, \eta_x)d\eta_x = \frac{e^{-\frac{1}{2\rho_t^2}(\eta_x - r_t\sigma_x)^2}}{\sqrt{2\pi\rho_t}}d\eta_x \tag{7}$$

with

$$\begin{aligned} r_t &= e^{-\frac{t}{2}} \\ \rho_t^2 &= \rho_\infty^2(1 - e^{-t}) \end{aligned} \tag{8}$$

Note that the only parameter of this dynamics is ρ_∞^2 which is the variance of the stationary distribution.

Keeping track of the parameters from the initial distribution and of the dynamics we use the following notation for the time-evolved measure at time t

$$\mu_{q, \rho^2, h; t, \rho_\infty^2}^{+, \text{OU}}(d\eta) = \int \mu_{q, \rho^2, h}^+(d\sigma) \prod_x p_t(\sigma_x, \eta_x)d\eta_x \tag{9}$$

It is immediate to see that this measure converges weakly to an infinite product over the lattice sites of centered Gaussians with variance ρ_∞^2 , when the time t tends to infinity. It is the purpose of this paper to understand what happens for $t < \infty$, in particular the properties of the conditional probabilities of the time-evolved measure, even if it is close to a product measure.

1.3. The notion of Gibbsianness for unbounded continuous-spin models

Since we are dealing with unbounded spins we need to be careful to give a reasonable definition of Gibbsianness. We will make the following definition.

Definition 1.2. We call $\xi \in \mathbb{R}^{\mathbb{Z}^d}$ a **good configuration** for μ if and only if, for all fixed $M < \infty$,

$$\begin{aligned} \sup_{\Lambda: \Lambda \supset V} \sup_{\substack{\omega^+, \omega^-: \\ \omega^+, \omega^- \in [-M, M]^{\mathbb{Z}^d}}} \left| \int f(\sigma_x)\mu(d\sigma_x | \xi_{V \setminus x} \omega_{\Lambda \setminus V}^+) \right. \\ \left. - \int f(\sigma_x)\mu(d\sigma_x | \xi_{V \setminus x} \omega_{\Lambda \setminus V}^-) \right| \rightarrow 0 \end{aligned} \tag{10}$$

with $V \uparrow \mathbb{Z}^d$, for any site $x \in \mathbb{Z}^d$, all any bounded continuous function $f : \mathbb{R} \mapsto \mathbb{R}$. We call μ **Gibbs** iff every configuration is good.

Note: In our definition we demand only continuity w.r.t. uniformly bounded perturbations. A measure whose finite-volume conditional probabilities correspond to a nice Hamiltonian of the form $H(\sigma) = \sum_{x,y} J_{x,y}\sigma_x\sigma_y$, where the $J_{x,y}$'s are rapidly decaying but not finite range, would never be Gibbs if arbitrary growing perturbations were allowed. This definition of Gibbsianness is less restrictive than

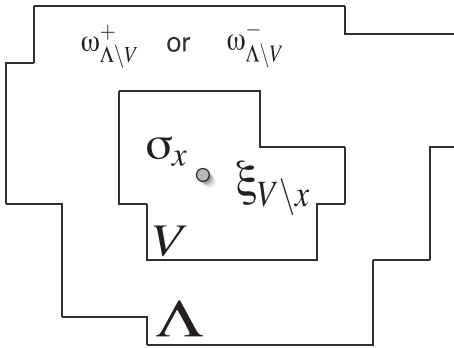

A conditioning ξ is perturbed outside the volume V .

the definition in terms of a uniformly summable potential given in [4] which is formulated in terms of a sup-norm of a potential. It is also less restrictive than the notion of a quasilocal specification, formulated without regard to a potential in terms as found in Georgii [9]. Both notions would imply that the convergence in (10) is uniform in M .

1.4. Main result

Now we are able to present our main result about the Gibbsian nature of the time-evolved measure.

Theorem 1.3. Assume that $d \geq 2, h \in \mathbb{R}$.

High-temperature regime. Assume that $q^{-1} > 2d(1 - \rho^2)$. Then:

(0) Then $\mu_{q, \rho^2, h; t, \rho_\infty^2}^{+, OU}$ is a Gibbs measure for all $t \geq 0$

Low-temperature regime. Assume that $q^{-1} < \beta_d^{-1} - 2d\rho^2$. Then there exist $t_0 \equiv t_0(q, \rho^2; \rho_\infty^2)$ and $t_1 \equiv t_1(q, \rho^2; \rho_\infty^2)$, independent of h , such that

- (i) $\mu_{q, \rho^2, h; t, \rho_\infty^2}^{+, OU}$ is a Gibbs measure for all $0 \leq t \leq t_0(q, \rho^2; \rho_\infty^2)$.
- (ii) $\mu_{q, \rho^2, h; t, \rho_\infty^2}^{+, OU}$ is not a Gibbs measure for all $t \geq t_1(q, \rho^2; \rho_\infty^2)$.

Note that part (ii) of the theorem is different in an important aspect from the result of [8] for discrete spins. In their case, for h different from zero, one encounters Gibbsianness again for sufficiently large times which is not the case here. Thus, for continuous unbounded spins there is no *out-and in of Gibbsianness*, but only an *out-of Gibbsianness*. Also, their proof of non-Gibbsianness for intermediate times in a non-vanishing external magnetic field requires that $d \geq 3$, while in our case we can do with $d \geq 2$.

Our proof of the failure of Gibbsianness consists in showing that the homogeneous configuration given by $\eta_x = -qhr_t^{-1}\rho_t^2 = -2qh\rho_\infty^2 \sinh \frac{t}{2}$ for all lattice sites $x \in \mathbb{Z}^d$ is a bad configuration (i.e. not good in the sense of Definition 1.2) for the time-evolved measure. As in [8] one needs to look at a quenched model which is obtained by conditioning the measure governing the initial spins on spin-values

observed at time t . In this quenched model the continuous-spin configuration $\eta = (\eta_x)_{\mathbb{Z}^d}$ that appears as a conditioning of the time-evolved measure acquires the role of quenched magnetic fields. Non-Gibbsianness of the time-evolved model then arises as a sensitive dependence of the quenched model under variation of the quenched magnetic field outside of arbitrary large volumes. This sensitivity will occur precisely for certain ‘balancing configurations’ η for which the quenched model has a phase transition. Now, the particular value of the homogeneous balancing configuration is determined by the requirement that the term coming from the transition kernels which is linear in σ , namely the sum $+\frac{1}{\rho_t^2} \sum_x r_t \eta_x \sigma_x$ cancels with the term in the initial Hamiltonian which is caused by the external magnetic field, namely $qh \sum_x \sigma_x$.

Note at this point already that for continuous-spin models it should be easier to find balancing configurations than for discrete models, since there are homogeneous configurations available at any possible constant spin value. The explicit analysis of our model one needs to perform is greatly simplified by the specific choice of the double-well potential in its definition. This relies on the fact that it can be written as a logarithm of two Gaussian densities centered at different values. By means of this property one discovers an underlying ‘hidden’ auxiliary discrete-spin model which can be used to control the low-temperature behavior of the continuous model without involved expansion techniques for continuous spins. In fact, potentials of this sort (or perturbations thereof) were already used in [11] to reduce the analysis of disordered continuous-spin models to discrete models.

Let us also point out that in the case of non-vanishing h the height of the balancing configuration diverges to infinity exponentially fast in t . In this sense ‘non-Gibbsianness is non-uniform in t ’. This phenomenon could not happen for a compact spin-space which is in accordance with the large- t Gibbsianness in the corresponding Ising model that was proved in [8].

Note the scaling-property of the Ornstein-Uhlenbeck process X_t to Brownian motion. It says that the rescaled path $r_t^{-1}X_t$ is the path of a Brownian motion at the rescaled time $s = r_t^{-2}\rho_t^2 = \rho_\infty^2(e^t - 1)$. So the measure μ_t^{OU} with Ornstein-Uhlenbeck time-evolution is related to a measure μ_t^{BM} obtained for independent Brownian motions by the formula

$$\int \mu_t^{\text{OU}}(d\eta)\varphi(r_t^{-1}\eta) = \int \mu_s^{\text{BM}}(d\eta)\varphi(\eta) \quad (11)$$

when both are started in the same measure. So, all properties of the finite-time Gibbs-measure μ_t can be studied for a measure that is evolved according to independent Brownian motions. This implies in particular that the dependence of the (bounds on the) threshold times t_0 and t_1 on the variance of the limiting distribution is trivially given by the rescaling formula for the time-change to Brownian motion. Obviously then, we could have formulated our theorem for Brownian motions. However we chose the present Ornstein-Uhlenbeck formulation to make obvious that, although there is a simple limiting distribution which is approached rapidly, non-Gibbsian behavior persists for any finite time.

It can be seen that the time at which some homogeneous configuration becomes a point of discontinuity for the conditional expectations of μ_t appears is sharp.

Since this configuration should be “the first point of discontinuity to appear” we conjecture that $t_1 = t_2$.

Note however that a sharp transition of an in- and out of Gibbsianness can be shown in the corresponding mean-field models [12]. Here a complete analysis can be given in terms of a bifurcation analysis of the rate function of the magnetisation of the quenched model conditioned on the empirical average of the spins. Let us just mention that, even for $h = 0$, also bad configurations are appearing that are not spin-flip symmetric. This phenomenon is not expected to occur here (but possibly in long-range lattice models).

The rest of the paper is organized as follows: In Section 2 we discuss the phase structure of the Hamiltonian of the initial measure and the relation to an underlying discrete Ising model, making use of the specific choice of the single-site potential. In Section 3 we study the conditional probabilities of the time-evolved measure and their relation to expectations in a discrete Ising model in a quenched random field. In Section 4 we prove our main result by showing presence or absence of phase transition in the quenched discrete Ising model of Section 3.

2. The initial measure - Gibbs measures of the log-double Gaussian model

The main purpose of this chapter is to give a proof of the phase transition result about the log-double Gaussian model Theorem 1.1.

To do so we discuss the precise relationship between the continuous model in the infinite volume, and an underlying Ising model whose couplings are given by the matrix elements of the resolvent of the lattice Laplacian. The brief message is that the reduction from continuous to discrete works fine at this point, and there are no worrisome infinite-volume pathologies arising at this step. The precise result is given in the ‘construction theorem’, Theorem 2.1, and in Theorem 2.2. Similar arguments will be used in the analysis of the time-evolved measure below.

Then, by simple stochastic domination arguments (Theorem 2.3), and comparison of the underlying Ising model with the nearest-neighbor Ising model, we get a sufficient condition for ferromagnetic order, as promised in Theorem 1.1. On the other hand, the unicity conditions follow from carrying over unicity for the discrete model, for which we just utilise Dobrushin uniqueness arguments.

Now, let us start with some definitions. We are interested in the analysis of the Gibbs measures on the state space $\Omega = \mathbb{R}^{\mathbb{Z}^d}$ of the continuous-spin model given by the Hamiltonians in finite-volume Λ by

$$\begin{aligned}
 H_{\Lambda}^{\tilde{\sigma}_{\partial\Lambda}}(\sigma_{\Lambda}) &= \frac{q}{2} \sum_{\substack{\{x,y\} \subset \Lambda \\ d(x,y)=1}} (\sigma_x - \sigma_y)^2 + \frac{q}{2} \sum_{\substack{x \in \Lambda; y \in \partial\Lambda \\ d(x,y)=1}} (\sigma_x - \tilde{\sigma}_y)^2 \\
 &\quad -qh \sum_{x \in \Lambda} \sigma_x + \sum_{x \in \Lambda} V_{\rho^2}(\sigma_x)
 \end{aligned} \tag{12}$$

for a configuration $\sigma_{\Lambda} \in \Omega_{\Lambda} = \mathbb{R}^{\Lambda}$ with boundary condition $\tilde{\sigma}_{\partial\Lambda}$. Here we write $\partial\Lambda = \{x \in \Lambda^c; \exists y \in \Lambda : d(x, y) = 1\}$ for the outer boundary of a set Λ where $d(x, y) = \|x - y\|_1$ is the 1-norm on \mathbb{R}^d .

The log-double Gaussian potential V_{ρ^2} has two different quadratic symmetric absolute minima if and only if $\rho^2 < 1$. We note that the positions of the minimizers are given by $m = \pm m^{CW}(\beta = \rho^{-2})$. Here $m^{CW}(\beta)$ denotes the largest solution of the well known equation $m = \tanh(\beta m)$. It happens to describe the magnetisation of the ordinary Ising mean field model, although this has no particular relevance in our model.

The Gibbs-specification (or ‘finite-volume Gibbs measures’) corresponding to this double-well model $\gamma_\Lambda^{dw}(d\sigma_\Lambda | \tilde{\sigma}_{\partial\Lambda})$ is then defined as usual through the expressions

$$\gamma_\Lambda^{dw}(f | \tilde{\sigma}_{\partial\Lambda}) = \frac{1}{Z_\Lambda^{\tilde{\sigma}_{\partial\Lambda}}} \int_{\mathbb{R}^\Lambda} d\sigma_\Lambda f(\sigma_\Lambda, \tilde{\sigma}_{\Lambda^c}) e^{-H_\Lambda^{\tilde{\sigma}_{\partial\Lambda}}(\sigma_\Lambda)} \tag{13}$$

for any bounded continuous f on Ω with the partition function

$$Z_\Lambda^{\tilde{\sigma}_{\partial\Lambda}} = \int_{\mathbb{R}^\Lambda} d\sigma_\Lambda e^{-H_\Lambda^{\tilde{\sigma}_{\partial\Lambda}}(\sigma_\Lambda)} \tag{14}$$

A different way of looking at this model is the following. Remember that

$$e^{-V_{\rho^2}(\sigma_x)} = C_1(\rho) \sum_{\tau_x = \pm 1} e^{-\frac{(\sigma_x - \tau_x)^2}{2\rho^2}} \tag{15}$$

Let us introduce new, auxiliary variables $\tau_x = \pm 1$ at each lattice site x . Then we introduce the so-called *joint Hamiltonian*

$$\begin{aligned} H_\Lambda^{\tilde{\sigma}_{\partial\Lambda}}(\sigma_\Lambda, \tau_\Lambda) &= \frac{q}{2} \sum_{\substack{\{x,y\} \subset \Lambda \\ d(x,y)=1}} (\sigma_x - \sigma_y)^2 + \frac{q}{2} \sum_{\substack{x \in \Lambda; y \in \partial\Lambda \\ d(x,y)=1}} (\sigma_x - \tilde{\sigma}_y)^2 - qh \sum_{x \in \Lambda} \sigma_x \\ &+ \frac{\rho^{-2}}{2} \sum_{x \in \Lambda} \sigma_x^2 - \rho^{-2} \sum_{x \in \Lambda} \sigma_x \tau_x \end{aligned} \tag{16}$$

This Hamiltonian thus corresponds to keeping only the Gaussians corresponding to τ_x in (15) at each lattice site x in the partition sum. We note that we have by definition of the potential the identity

$$\exp\left(-H_\Lambda^{\tilde{\sigma}_{\partial\Lambda}}(\sigma_\Lambda)\right) = C_2(\rho)^{|\Lambda|} \sum_{\tau_\Lambda} \exp\left(-H_\Lambda^{\tilde{\sigma}_{\partial\Lambda}}(\sigma_\Lambda, \tau_\Lambda)\right) \tag{17}$$

In this way one can view the model defined in terms of the Gibbs specification corresponding to the joint Hamiltonian (16) for the joint variables $(\sigma_x, \tau_x)_{x \in \mathbb{Z}^d}$. Here the interaction is only through the σ -part of the model. We also note that, conditional on a configuration of the τ -variables, the σ -variables have a Gaussian distribution. These facts will be the reason for the simplicity of the model.

A complementary view on the introduction of the τ -variables is by the introduction of a stochastic transition from the σ -variables to the τ -variables. So, let us now introduce the following stochastic kernels T describing the probabilities for

transitions from a continuous-spin configuration σ to a discrete configuration τ . We define

$$T(\tau_x|\sigma_x) := \frac{e^{\frac{\sigma_x \tau_x}{\rho^2}}}{2 \cosh(\frac{\sigma_x}{\rho^2})} = \frac{1}{2} \left(1 + \tau_x \tanh(\rho^{-2} \sigma_x) \right) \tag{18}$$

so that the conditional expectation becomes $\sum_{\tau_x = \pm 1} \tau_x \nu(\tau_x|\sigma_x) = \tanh(\frac{\sigma_x}{\rho^2})$. So, T corresponds to a randomized sign-map under which the continuous spins σ_x take their sign with probability $\frac{1}{2} \left(1 + \tanh(\rho^{-2} |\sigma_x|) \right)$

We will then also write T for the stochastic kernel obtained by sitewise independent application of (18). We note that we have by definition of the potential the identity

$$\exp \left(-H_{\Lambda}^{\tilde{\sigma}_{\partial \Lambda}}(\sigma_{\Lambda}, \tau_{\Lambda}) \right) = 2^{|\Lambda|} \exp \left(-H_{\Lambda}^{\tilde{\sigma}_{\partial \Lambda}}(\sigma_{\Lambda}) \right) \prod_{x \in \Lambda} T(\tau_x|\sigma_x) \tag{19}$$

2.1. Relation to Ising model with resolvent-interaction

We will now state the precise relation between the Gibbs measure in *infinite* volume of the measure on the continuous variables and the measure on the discrete variables. We remind the reader of the fact that, in general, taking projections of Gibbs-measures does not necessarily preserve the Gibbsian nature of the measure. So, e.g. it is not immediate a priori that the infinite-volume marginal distribution on the τ -variables should be described by a Gibbs measure. We will however prove that this is the case. Loosely speaking, the measure $T(\mu)$ projected on the τ 's is Gibbs, because the measure on the σ 's conditional on the τ 's does not show a phase transition when we vary the τ 's. This will be clear because, as we will see, it is a massive Gaussian with τ -dependent expectation, and this dependence is effectively local because of the exponential decay of the matrix elements of the resolvent.

In some sense $T(\mu)$ contains the relevant information of μ . Since $T(\mu)$ shows a phase transition, as we will see, this carries over also to μ .

For finite volumes the corresponding results are direct consequences of simple Gaussian computations. To carry over these relations to the infinite volume is not too difficult but needs care.

Define the *Ising Hamiltonian with resolvent interaction* by the expression

$$H^{\text{Ising}}(\tau) = -\frac{\rho^{-4}}{2} \sum_{x,y} \left(\rho^{-2} - q \Delta_{\mathbb{Z}^d} \right)_{x,y}^{-1} \tau_x \tau_y - qh \sum_x \tau_x \tag{20}$$

where $\Delta_{\mathbb{Z}^d}$ is the lattice Laplacian in the infinite volume, i.e. $\Delta_{\mathbb{Z}^d;x,y} = 1$ iff $x, y \in V$ are nearest neighbors, $\Delta_{\mathbb{Z}^d;x,y} = -2d$ iff $x = y$ and $\Delta_{\mathbb{Z}^d;x,y} = 0$ else.

Note that the couplings $\rho^{-4} \sum_{x,y} \left(\rho^{-2} - q \Delta_{\mathbb{Z}^d} \right)_{x,y}^{-1}$ are decaying exponentially fast in the distance between x and y and so the interaction potential is in particular absolutely summable.

For every infinite-volume discrete-spin configuration $\tau_{\mathbb{Z}^d}$ define an ‘interpolating’ continuous configuration by

$$\sigma_{\mathbb{Z}^d}(\tau_{\mathbb{Z}^d}) = (1 - q\rho^2 \Delta_{\mathbb{Z}^d})^{-1} \tau_{\mathbb{Z}^d} + \rho^2 q h 1_{\mathbb{Z}^d} \tag{21}$$

Then we have the following statements.

Theorem 2.1. *Suppose that ν is a Gibbs measure for the Ising Hamiltonian (20). Then the measure*

$$\mu(d\sigma) = \int \nu(d\tau_{\mathbb{Z}^d}) N \left[\sigma_{\mathbb{Z}^d}(\tau_{\mathbb{Z}^d}); \left(\rho^{-2} - q \Delta_{\mathbb{Z}^d} \right)^{-1} \right] (d\sigma) \tag{22}$$

is a Gibbs measure for the continuous specification γ^{dw} .

The symbol $N \left[a; \left(\rho^{-2} - q \Delta_{\mathbb{Z}^d} \right)^{-1} \right]$ denotes the massive Gaussian field on the infinite lattice \mathbb{Z}^d , centered at $a \in \mathbb{R}^{\mathbb{Z}^d}$ with covariance matrix given by the second argument (i.e. $\int N \left[a; \left(\rho^{-2} - q \Delta_{\mathbb{Z}^d} \right)^{-1} \right] (d\sigma) (\sigma_x - a_x) (\sigma_y - a_y) = \left[\left(\rho^{-2} - q \Delta_{\mathbb{Z}^d} \right)^{-1} \right]_{x,y}$).

We see that, when the strength q of the continuous model tends to zero, the massive Gaussian field will converge to a collection of independent Gaussians with variance ρ^2 .

Note that Theorem 2.1 allows us to construct continuous-spin Gibbs measures from discrete-spin Gibbs measures.

Theorem 2.2. *Suppose that μ is a continuous-spin Gibbs-measure in the sense of the DLR equation for the specification γ^{dw} corresponding to the Hamiltonian (20), such that $\sup_{x \in \mathbb{Z}^d} \mu(e^{\varepsilon |\sigma_x|}) < \infty$ for some $\varepsilon > 0$.*

(i) *Then, the infinite-volume image measure $T(\mu)$ on $\{-1, 1\}^{\mathbb{Z}^d}$ is a Gibbs measure for the absolutely summable Ising-Hamiltonian (20).*

(ii) *The continuous-spin measure obtained by conditioning on the discrete variables in infinite volume is Gaussian. Moreover, for all $\tau_{\mathbb{Z}^d}$ we have the limit*

$$\lim_{\Lambda \uparrow \mathbb{Z}^d} \mu(\cdot | \tau_\Lambda) = N \left[\sigma_{\mathbb{Z}^d}(\tau_{\mathbb{Z}^d}); \left(\rho^{-2} - q \Delta_{\mathbb{Z}^d} \right)^{-1} \right] \tag{23}$$

Before we give the proofs of the theorems let us compute the distribution of the σ_Λ conditional on the τ_Λ in a finite volume Λ . Using an obvious vector notation let us first rewrite

$$H_\Lambda^{\sigma_\Lambda}(\sigma_\Lambda, \tau_\Lambda) = \frac{1}{2} \langle \sigma_\Lambda, (\rho^{-2} - q \Delta_\Lambda) \sigma_\Lambda \rangle - \langle \sigma_\Lambda, q h 1_\Lambda + \rho^{-2} \tau_\Lambda + q \partial_{\Lambda, \Lambda^c} \sigma_{\partial \Lambda} \rangle \tag{24}$$

Here Δ_Λ is the lattice Laplacian with Dirichlet boundary conditions in Λ , i.e. $\Delta_{\Lambda; x,y} = \Delta_{\mathbb{Z}^d; x,y}$ for $x, y \in \Lambda$, and zero otherwise. Furthermore we have put

$\partial_{\Lambda, \Lambda^c; x, y} = 1$, if $x \in \Lambda$, $y \in \Lambda^c$ and x, y are nearest neighbors. Now, plugging in the value at the minimizer for given τ ,

$$\sigma_{\Lambda}^{\sigma_{\partial\Lambda}}(\tau_{\Lambda}) := (\rho^{-2} - q\Delta_{\Lambda})^{-1}(qh1_{\Lambda} + \rho^{-2}\tau_{\Lambda} + q\partial_{\Lambda, \Lambda^c}\sigma_{\partial\Lambda}) \tag{25}$$

gives us in (24)

$$\begin{aligned} &-\frac{1}{2}\langle (qh1_{\Lambda} + \rho^{-2}\tau_{\Lambda} + q\partial_{\Lambda, \Lambda^c}\sigma_{\partial\Lambda}), (\rho^{-2} - q\Delta_{\Lambda})^{-1} \\ &\quad \times (qh1_{\Lambda} + \rho^{-2}\tau_{\Lambda} + q\partial_{\Lambda, \Lambda^c}\sigma_{\partial\Lambda}) \rangle \end{aligned} \tag{26}$$

Collecting τ -dependent terms we get the ‘finite-volume Ising-Hamiltonian’

$$\begin{aligned} H_{\Lambda}^{\text{Ising}, \sigma_{\partial\Lambda}}(\tau_{\Lambda}) := &-\frac{\rho^{-4}}{2}\langle \tau_{\Lambda}, (\rho^{-2} - q\Delta_{\Lambda})^{-1}\tau_{\Lambda} \rangle \\ &-\rho^{-2}\langle \tau_{\Lambda}, (\rho^{-2} - q\Delta_{\Lambda})^{-1}(qh1_{\Lambda} + q\partial_{\Lambda, \Lambda^c}\sigma_{\partial\Lambda}) \rangle \end{aligned} \tag{27}$$

This is the finite-volume version of (20), still including the dependence on the *continuous-spin* boundary condition $\sigma_{\partial\Lambda}$.

With this notation, it is clear that the measure on the σ_{Λ} conditional on the τ_{Λ} can be written as

$$\begin{aligned} &\exp\left(-H_{\Lambda}^{\sigma_{\partial\Lambda}}(\sigma_{\Lambda}, \tau_{\Lambda})\right)d\sigma_{\Lambda} \\ &= C \exp\left(-H_{\Lambda}^{\text{Ising}, \sigma_{\partial\Lambda}}(\tau_{\Lambda})\right)N\left[\sigma_{\Lambda}^{\sigma_{\partial\Lambda}}(\tau_{\Lambda}); \left(\rho^{-2} - q\Delta_{\Lambda}\right)^{-1}\right](d\sigma_{\Lambda}) \end{aligned} \tag{28}$$

This follows by centering the quadratic form in the exponent on the l.h.s. at its minimizer. Of course the τ -independent constant C is just the usual Gaussian normalization constant that is provided by the determinant of the covariance operator.

Now, the proofs of the Theorems 2.1 and 2.2 both use at some step (28). One then takes the infinite-volume limit in a suitable way, making use of good approximation properties of the infinite-volume resolvent by the finite-volume resolvent.

Proof of Theorem 2.1. We need to verify the DLR equation for the continuous-spin measure μ , defined by the r.h.s. of (22), assuming that ν satisfies the discrete-spin DLR equation for the Ising Hamiltonian (20). It suffices to look at single-site sets $\{x\}$ and so we must check that

$$\begin{aligned} &\int \nu(d\tau_{\mathbb{Z}^d})N\left[\sigma_{\mathbb{Z}^d}(\tau_{\mathbb{Z}^d}); \left(\rho^{-2} - q\Delta_{\mathbb{Z}^d}\right)^{-1}\right](d\sigma_{x^c})\gamma_x^{\text{dw}}(d\sigma_x|\sigma_{\partial x}) \\ &= \int \nu(d\tau_{\mathbb{Z}^d})N\left[\sigma_{\mathbb{Z}^d}(\tau_{\mathbb{Z}^d}); \left(\rho^{-2} - q\Delta_{\mathbb{Z}^d}\right)^{-1}\right](d\sigma_{x^c}d\sigma_x) \end{aligned} \tag{29}$$

The above continuous-spin DLR-equation (29) follows for any discrete-spin Gibbs measure ν by means of the discrete DLR-property for ν if we can check that

$$\begin{aligned} & \sum_{\tau_x} \nu(\tau_x | \tau_{x^c}) \\ & \int N \left[\sigma_{\mathbb{Z}^d}(\tau_x, \tau_{x^c}); \left(\rho^{-2} - q \Delta_{\mathbb{Z}^d} \right)^{-1} \right] (d\sigma_{x^c}) \int \gamma_x^{\text{dw}}(d\sigma_x | \sigma_{\partial x}) \varphi(\sigma_x, \sigma_V) \\ & = \sum_{\tau_x} \nu(\tau_x | \tau_{x^c}) \int N \left[\sigma_{\mathbb{Z}^d}(\tau_x, \tau_{x^c}); \left(\rho^{-2} - q \Delta_{\mathbb{Z}^d} \right)^{-1} \right] (d\sigma_{x^c} d\sigma_x) \varphi(\sigma_x, \sigma_V) \end{aligned} \tag{30}$$

holds for all τ_{x^c} , and for all local observables φ , i.e. V finite. Indeed, integrating (30) in the measure $\nu(d\tau_{x^c})$ implies (29).

We will verify the latter equation (30) by a finite-volume approximation of the objects appearing. From the exponential convergence $\lim_{\Lambda \uparrow \mathbb{Z}^d} (\rho^{-2} - q \Delta_\Lambda)_{x,y}^{-1} = (\rho^{-2} - q \Delta)_{x,y}^{-1}$ we have for any boundary condition $\bar{\sigma}$ with $\sup_x |\bar{\sigma}_x| < \infty$ that

$$\begin{aligned} & \lim_{\Lambda \uparrow \mathbb{Z}^d} \nu_\Lambda^{\text{Ising}, \bar{\sigma}_{\partial \Lambda}}(\tau_x | \tau_{\Lambda \setminus x}) = \nu(\tau_x | \tau_{x^c}), \\ & \lim_{\Lambda \uparrow \mathbb{Z}^d} \int N \left[\sigma_\Lambda^{\bar{\sigma}_{\partial \Lambda}}(\tau_\Lambda); \left(\rho^{-2} - q \Delta_\Lambda \right)^{-1} \right] (d\sigma_W) \psi(\sigma_W) \\ & = \int N \left[\sigma_{\mathbb{Z}^d}(\tau_{\mathbb{Z}^d}); \left(\rho^{-2} - q \Delta_{\mathbb{Z}^d} \right)^{-1} \right] (d\sigma_W) \psi(\sigma_W) \end{aligned} \tag{31}$$

for any bounded local function $\psi(\sigma_W)$.

Therefore, it suffices to show the following finite-volume identity

$$\begin{aligned} & \sum_{\tau_x} \int \nu_\Lambda^{\text{Ising}, \sigma_{\partial \Lambda}}(\tau_x | \tau_{\Lambda \setminus x}) \\ & N \left[\sigma_\Lambda^{\sigma_{\partial \Lambda}}(\tau_x, \tau_{\Lambda \setminus x}); \left(\rho^{-2} - q \Delta_\Lambda \right)^{-1} \right] (d\sigma_{\Lambda \setminus x}) \gamma_x^{\text{dw}}(d\sigma_x | \sigma_{\partial x}) \\ & = \sum_{\tau_x} \int \nu_\Lambda^{\text{Ising}, \sigma_{\partial \Lambda}}(\tau_x | \tau_{\Lambda \setminus x}) \\ & N \left[\sigma_\Lambda^{\sigma_{\partial \Lambda}}(\tau_x, \tau_{\Lambda \setminus x}); \left(\rho^{-2} - q \Delta_\Lambda \right)^{-1} \right] (d\sigma_{\Lambda \setminus x} d\sigma_x) \end{aligned} \tag{32}$$

for all $\sigma_{\partial \Lambda}$ and all Λ .

Indeed, then the desired consistency equation (30) follows by taking Λ going to \mathbb{Z}^d in (32) and choosing one particular bounded σ , e.g. $\sigma \equiv 0$, ensuring that (31) holds.

In order to prove (32) first we add τ_x -independent terms to the Ising-Hamiltonian appearing in the explicit expression for $\nu_\Lambda^{\text{Ising}, \sigma_{\partial\Lambda}}(\tau_x | \tau_{\Lambda \setminus x})$ to rewrite (32) in the form

$$\begin{aligned} & \sum_{\tau_x} \exp\left(-H_\Lambda^{\text{Ising}, \sigma_{\partial\Lambda}}(\tau_x, \tau_{\Lambda \setminus x})\right) \\ & N \left[\sigma_\Lambda^{\sigma_{\partial\Lambda}}(\tau_x, \tau_{\Lambda \setminus x}); \left(\rho^{-2} - q\Delta_\Lambda\right)^{-1} \right] (d\sigma_{\Lambda \setminus x}) \gamma_x^{\text{dw}}(d\sigma_x | \sigma_{\partial x}) \\ & = \sum_{\tau_x} \exp\left(-H_\Lambda^{\text{Ising}, \sigma_{\partial\Lambda}}(\tau_x, \tau_{\Lambda \setminus x})\right) \\ & N \left[\sigma_\Lambda^{\sigma_{\partial\Lambda}}(\tau_x, \tau_{\Lambda \setminus x}); \left(\rho^{-2} - q\Delta_\Lambda\right)^{-1} \right] (d\sigma_{\Lambda \setminus x} d\sigma_x) \end{aligned} \quad (33)$$

Reading (28) from the right to the left we see that (33) is equivalent to the simple equation

$$\begin{aligned} & \sum_{\tau_x} \int d\tilde{\sigma}_x \exp\left(-H_\Lambda^{\sigma_{\partial\Lambda}}(\tilde{\sigma}_x \sigma_{\Lambda \setminus x}, \tau_x, \tau_{\Lambda \setminus x})\right) d\sigma_{\Lambda \setminus x} \gamma_x^{\text{dw}}(d\sigma_x | \sigma_{\partial x}) \\ & = \sum_{\tau_x} \exp\left(-H_\Lambda^{\sigma_{\partial\Lambda}}(\sigma_x \sigma_{\Lambda \setminus x}, \tau_x, \tau_{\Lambda \setminus x})\right) d\sigma_{\Lambda \setminus x} d\sigma_x \end{aligned} \quad (34)$$

But substituting the definition of the double-well specification

$$\gamma_x^{\text{dw}}(d\sigma_x | \sigma_{\partial x}) = \frac{\sum_{\tilde{\tau}_x} \exp\left(-H_x^{\sigma_{\partial x}}(\tilde{\sigma}_x, \tau_x)\right)}{\int d\tilde{\sigma}_x \sum_{\tilde{\tau}_x} \exp\left(-H_x^{\sigma_{\partial x}}(\tilde{\sigma}_x, \tilde{\tau}_x)\right)} \quad (35)$$

we see that (34) is in fact an identity. \square

Proof of Theorem 2.2. Let us prove (i). To show the Gibbs-property of $T(\mu)$ we will show that, for any infinite-volume spin configuration τ , we have

$$\lim_{\Lambda \uparrow \mathbb{Z}^d} T(\mu)(\tau_x | \tau_{\Lambda \setminus x}) = \frac{\exp\left(\tau_x \left(\sum_{y \in \Lambda \setminus x} \rho^{-4} (\rho^{-2} - q\Delta_{x,y})^{-1} \tau_y + qh\right)\right)}{\sum_{\tilde{\tau}_x = \pm 1} \exp\left(\tilde{\tau}_x \left(\sum_{y \in \Lambda \setminus x} \rho^{-4} (\rho^{-2} - q\Delta_{x,y})^{-1} \tau_y + qh\right)\right)} \quad (36)$$

where we take the limit along growing cubes.

Writing the finite-volume conditional probability in the form

$$T(\mu)(\tau_x | \tau_{\Lambda \setminus x}) = \frac{\int \mu(d\sigma_{\partial\Lambda}) \int \gamma_\Lambda^{\text{dw}, \sigma_{\partial\Lambda}}(d\sigma_\Lambda) T_\Lambda(\tau_x \tau_{\Lambda \setminus x} | \sigma_\Lambda)}{\sum_{\tilde{\tau}_x = \pm 1} \int \mu(d\sigma_{\partial\Lambda}) \int \gamma_\Lambda^{\text{dw}, \sigma_{\partial\Lambda}}(d\sigma_\Lambda) T_\Lambda(\tilde{\tau}_x \tau_{\Lambda \setminus x} | \sigma_\Lambda)} \quad (37)$$

we get

$$T(\mu)(\tau_x | \tau_{\Lambda \setminus x}) = \frac{\exp\left(\tau_x \left(\sum_{y \in \Lambda \setminus x} J_{x,y}^\Lambda \tau_y + h_x^\Lambda\right)\right) R_x^\Lambda(\tau_x)}{\sum_{\tilde{\tau}_x = \pm 1} \exp\left(\tilde{\tau}_x \left(\sum_{y \in \Lambda \setminus x} J_{x,y}^\Lambda \tau_y + h_x^\Lambda\right)\right) R_x^\Lambda(\tilde{\tau}_x)} \quad (38)$$

with

$$\begin{aligned}
 J_{x,y}^\Lambda &= \rho^{-4}(\rho^{-2} - q\Delta_\Lambda)_{x,y}^{-1} \\
 h_x^\Lambda &= \rho^{-2}qh \sum_{y \in \Lambda} (\rho^{-2} - q\Delta_\Lambda)_{x,y}^{-1} \\
 R_x^\Lambda(\tau_x) &= \int \mu(d\sigma_{\partial\Lambda}) \exp\left(\rho^{-2}\tau_x \sum_{y \in \Lambda, z \in \partial\Lambda} (\rho^{-2} - q\Delta_\Lambda)_{x,y}^{-1} q\partial_{y,z}\sigma_z\right) \quad (39)
 \end{aligned}$$

But note that $R_x^\Lambda(\tau_x) \rightarrow 1$, as Λ goes to \mathbb{Z}^d , is implied by the existence of exponential moments of μ , uniformly in x . This can be seen using Hölder’s inequality to estimate the r.h.s. in terms of $\mu(e^{\varepsilon\sigma_z})$, where ε can be made arbitrarily small for large Λ , by the exponential decay of $(\rho^{-2} - q\Delta_\Lambda)_{x,y}^{-1}$ in $|x - y|$.

But from the properties of the resolvent it is clear that $J_{x,y}^\Lambda$ and h_x^Λ converge to their infinite-volume counterparts. So we have the convergence (36), and moreover this convergence is uniform in τ .

To prove (ii) let us rewrite

$$\mu(d\sigma_\Lambda | \tau_\Lambda) = \int \mu(d\sigma_{\partial\Lambda}) N \left[\sigma_\Lambda^{\sigma_{\partial\Lambda}}(\tau_\Lambda); \left(\rho^{-2} - q\Delta_\Lambda\right)^{-1} \right] (d\sigma_\Lambda) \quad (40)$$

But from here follows the expression for the limit from the convergence of the resolvent and the existence of exponential moments of μ , uniformly in x . \square

2.2. Phase transitions in the log-double Gaussian model

Note first that for both continuous-spin and discrete-spin measures we have the notion of stochastic domination between measures. (Recall that for two measures one says that $\rho_1 \geq \rho_2$ stochastically iff $\rho_1(f) \geq \rho_2(f)$ for all monotone functions f , the latter meaning that $f(\sigma) \leq f(\sigma')$ if $\sigma_x \leq \sigma'_x$ for all $x \in \mathbb{Z}^d$.)

But then the representation formula of Theorem 2.2 tells us that stochastic domination carries over from the discrete-spin measures to the continuous-spin measures. More precisely we have the following.

Theorem 2.3. *Suppose that ν_1 and ν_2 are Gibbs measures for the Ising-Hamiltonian (20), and assume that $\nu_1 \leq \nu_2$ stochastically.*

Define corresponding continuous-spin measures μ_1, μ_2 in terms of (22).

Then we have $\mu_1 \leq \mu_2$ stochastically.

Proof. This is clear since the interpolating continuous-spin configuration (21) is a monotone function of the discrete-spin configuration τ , by the positivity of the matrix elements of $(\rho^{-2} - q\Delta_{\mathbb{Z}^d})^{-1}$. Since the massive Gaussian field behaves monotone under monotone change of the centering this proves the claim. \square

We note that there is monotonicity of the Gibbs measures also in the external magnetic field h , that is $\mu_{h_1} \leq \mu_{h_2}$ for $h_1 \leq h_2$ when both measures are constructed from discrete-spin measures obtained with the same boundary condition. This is clear for the same type of reasoning.

Let us now focus on the resolvent-coupling Ising model. To make things more transparent let us rewrite its formal infinite-volume Hamiltonian (20) in the form

$$H_{a_0, \lambda}^{\text{Ising}}(\tau) = -a_0 \sum_{\substack{x, y \\ x \neq y}} \sum_{n=1}^{\infty} \lambda^n (\partial^n)_{x, y} \tau_x \tau_y - qh \sum_x \tau_x \tag{41}$$

where we have written ∂ for the non-diagonal part of the lattice Laplacian, i.e. $\partial_{x, y} = 1$ iff $x, y \in \mathbb{Z}^d$ are nearest neighbors, $\partial_{x, y} = 0$ else. So we have $\Delta_{\mathbb{Z}^d} = \partial - 2dI$.

In (41) we have introduced the ‘natural parameters’

$$a_0 = \frac{1}{\rho^2(1 + 2dq\rho^2)}, \quad \lambda = \frac{q\rho^2}{1 + 2dq\rho^2} \in [0, \frac{1}{2d}) \tag{42}$$

This representation is obtained from the series expansion of $\rho^{-4}(\rho^{-2} - q\Delta_{\mathbb{Z}^d})^{-1} = a_0(I - \lambda\partial)^{-1}$. Note that we have dropped the $n = 0$ -term since it contributes just a constant w.r.t. the spin configurations τ to the Ising Hamiltonian.

We may now formulate the following result about the Gibbs measures.

Theorem 2.4. *Consider the Ising model with Hamiltonian given (41), parametrized by the natural parameters $a_0 > 0$ and $\lambda > 0$, with zero external magnetic field $h = 0$. Then the following is true.*

(i) *There is a non-increasing function $\lambda \mapsto a_0^*(\lambda)$ from the interval $(0, \frac{1}{2d})$ to the positive real numbers such that, for all $\lambda \in (0, \frac{1}{2d})$:*

- *For $a_0 < a_0^*(\lambda)$ the Gibbs measure is unique.*
- *For $a_0 > a_0^*(\lambda)$ the infinite-volume plus state ν^+ (constructed with plus-boundary conditions) is different from the corresponding minus state ν^- .*

(ii) *We have the bounds*

$$\frac{1}{2d\lambda} - 1 \leq a_0^*(\lambda) \leq \frac{\beta_d}{\lambda} \tag{43}$$

Proof. Note that all coupling constants $a_0\lambda^n(\partial^n)_{x, y}$ are non-negative, and monotone functions of the parameters a_0 and λ , for any n . So, by monotonicity there exists an infinite-volume measure $\mu_{a_0, \lambda}^+$, obtained as a finite-volume limit with plus boundary conditions.

To prove (i) use Holley’s inequality to see that the expectation $\mu_{a_0, \lambda}^+(\tau_x = 1)$ is a monotone function of a_0 and λ , by the positivity of all the couplings in the Hamiltonian (41).

Let’s prove the r.h.s. of (ii). By monotonicity we can estimate the transition temperature of the model by keeping just the nearest neighbor term obtained from $n = 1$ with the coupling $a_0\lambda = \beta$. Denoting the corresponding measures by the superscript nn we have $\mu_{a_0, \lambda}^+ \geq \mu_{\beta}^{\text{nn}, +} \geq \mu_{\beta}^{\text{nn}, -} \geq \mu_{a_0, \lambda}^-$. So $a_0\lambda$ greater or equal than the critical inverse temperature β_d implies $\mu_{a_0, \lambda}^+ > \mu_{a_0, \lambda}^-$. This proves the upper estimate on the critical value $a_0^*(\lambda)$.

Let's prove the l.h.s. of (ii). This is based on Dobrushin uniqueness. Introduce the Dobrushin interaction matrix

$$C_{x,y} := \sup_{\xi=\xi' \text{ on } y^c} \|\mu(\cdot | \xi_{x^c}) - \mu(\cdot | \xi'_{x^c})\|_x \tag{44}$$

and put for the Dobrushin constant

$$c \equiv \sup_{x \in \Gamma} \sum_{y \in \Gamma} C_{x,y} \tag{45}$$

If $c < 1$ one says that the specification obeys the Dobrushin-uniqueness condition, and this implies unicity of the Gibbs measure.

It is a standard estimate in the context of Dobrushin-uniqueness that we have for the Dobrushin-interaction matrix associated to any interaction potential Φ the bound $C_{x,y} \leq \frac{1}{2} \sum_{A \supset \{x,y\}} \delta(\Phi_A)$. Here $\delta(\Phi_A) = \sup_{\sigma,\sigma'} |\Phi_A(\sigma) - \Phi_A(\sigma')|$ denotes the variation of Φ_A .

In our case (41) we have $\Phi_{\{x,y\}}(\tau_x, \tau_y) = -a_0 \sum_{n=1}^{\infty} \lambda^n (\partial^n)_{x,y} \tau_x \tau_y$ which implies the simple estimate

$$C_{x,y} \leq a_0 \sum_{n=1}^{\infty} \lambda^n (\partial^n)_{x,y} \tag{46}$$

But this gives the upper bound on the Dobrushin constant

$$c \leq a_0 \sum_{n=1}^{\infty} \lambda^n \sum_y (\partial^n)_{0,y} \leq a_0 \sum_{n=1}^{\infty} \lambda^n (2d)^n = a_0 \frac{2d\lambda}{1 - 2d\lambda} \tag{47}$$

and this gives the estimate on the l.h.s. of (43). □

Proof of Theorem 1.1. The proof follows in an obvious way from the results of this chapter. We define μ^+ by

$$\mu_{q,\rho^2,h}^+(d\sigma) := \int v_{q,\rho^2,h}^+(d\tau) N \left[\sigma_{\mathbb{Z}^d}(\tau_{\mathbb{Z}^d}); \left(\rho^{-2} - q \Delta_{\mathbb{Z}^d} \right)^{-1} \right] \tag{48}$$

μ^- is defined similarly via v^- . The conditions given in Theorem 1.1 on q^{-1} are a reformulation of the conditions from Theorem 2.4 (ii) in terms of the original parameters. The stochastic domination $\mu^+ > \mu^-$ for $h = 0$ in the continuous model follows from the stochastic domination $v^+ > v^-$ in the Ising model (which holds by non-negativity of the couplings) and Theorem 2.3. □

3. Time evolution-quenched model

Let us now come back to the time evolution involving independent diffusions with transition kernels given by the Ornstein-Uhlenbeck semigroup (7). Using the scaling of the Ornstein-Uhlenbeck paths to Brownian motions (11) it suffices to consider the Brownian semigroup at the rescaled time s , given by

$$p_s^{\text{BM}}(\sigma_x, \eta_x) = \frac{e^{-\frac{1}{2s}(\eta_x - \sigma_x)^2}}{\sqrt{2\pi s}} \tag{49}$$

We start the time evolution from the continuous-spin plus state $\mu_{q,\rho^2,h}^+(d\sigma)$, see (48).

Let us write for the resulting time-evolved measure

$$\mu_{q,\rho^2,h;s}^{+, \text{BM}}(d\eta) = \int \mu_{q,\rho^2,h}^+(d\sigma) \prod_x p_s^{\text{BM}}(\sigma_x, \eta_x) d\eta_x \tag{50}$$

So, a density for the finite-volume single-site conditional probabilities is given by

$$\mu_{q,\rho^2,h;s}^{+, \text{BM}}(d\eta_0 | \eta_{V \setminus 0}) = \frac{\int \mu_{q,\rho^2,h}^+(d\sigma) \prod_{x \in V \setminus 0} \frac{e^{-\frac{1}{2s}(\sigma_x - \eta_x)^2}}{\sqrt{2\pi s}} \times \frac{e^{-\frac{1}{2s}(\sigma_0 - \eta_0)^2}}{\sqrt{2\pi s}} d\eta_0}{\int \mu_{q,\rho^2,h}^+(d\sigma) \prod_{x \in V \setminus 0} \frac{e^{-\frac{1}{2s}(\sigma_x - \eta_x)^2}}{\sqrt{2\pi s}}} \tag{51}$$

Spelling out the μ^+ -Gibbs expectation over σ we obtain an expectation of a function of σ_0 in a quenched random field model. Here the ‘random fields’ η are present only in the finite set $V \setminus 0$. In the sequel it is necessary that we will keep finite this volume $W \equiv V \setminus 0$ where the conditioning η is fixed.

Let us summarize how we will proceed now in the investigation of the continuity properties of the conditional probabilities of the time-evolved measure $\mu_{q,\rho^2,h;s}^{+, \text{BM}}(d\eta)$.

(51) is a σ -expectation in a quenched random field model where η is acting as a random field. To this quenched random field model in σ there corresponds a quenched random field model in the discrete τ -variables. This is very much analogous to the translation-invariant case.

To show the presence (resp. absence) of discontinuous behavior of the conditional probabilities of the time-evolved measure we study presence (resp. absence) of a phase transition in the quenched τ -model, as a function of η , when we let V tend to \mathbb{Z}^d . More precisely, a discontinuity will occur if there is an η for which there is a phase transition in the quenched τ -model.

3.1. Relation to quenched Ising model with resolvent-interaction - Reducing Gibbs versus non-Gibbs to a discrete-spin question

To analyse the model we will use the same continuous-to-discrete reduction strategy as in Chapter 2. The difference is, obviously, the presence of the fixed random fields.

Let us present a formal computation in the infinite volume in order to motivate the definitions to follow. This computation is the formal infinite-volume version of the steps given in (24) ff. in the present η -dependent context. We do the same transformation to discrete variables τ as we did before. In matrix notation this gives us (in the infinite volume) the quadratic expression

$$\sigma \mapsto \frac{1}{2} \langle \sigma, (\rho^{-2} + s^{-1} I_W - q \Delta_{\mathbb{Z}^d}) \sigma \rangle - \langle qh1 + \rho^{-2} \tau + s^{-1} \eta_W, \sigma \rangle \quad (52)$$

for the conditional expectation of σ 's given the τ -variables.

The ‘minimizer’ of this functional is obtained by taking the gradient w.r.t. σ . This minimizer is the generalization of the ‘interpolating’ τ -dependent infinite-volume continuous configuration (21). It will now depend on the random field η_W in the finite volume W , and we will use the following notation:

$$\sigma_{\mathbb{Z}^d}^{W,s}[\eta_W](\tau_{\mathbb{Z}^d}) := (\rho^{-2} + s^{-1} I_W - q \Delta_{\mathbb{Z}^d})^{-1} (qh1 + \rho^{-2} \tau_{\mathbb{Z}^d} + s^{-1} \eta_W) \quad (53)$$

For $s \uparrow \infty$ this becomes identical to (21).

Substituting formally (53) into the infinite-volume functional (52) gives us a quadratic expression in τ that depends also on η . So, collecting τ -dependent terms, let us first define the absolutely summable quenched random field Ising-Hamiltonian

$$\begin{aligned} H^{\text{Ising}, W, s}[\eta_W](\tau) &:= -\frac{\rho^{-4}}{2} \sum_{x,y} (\rho^{-2} + s^{-1} I_W - q \Delta_{\mathbb{Z}^d})_{x,y}^{-1} \tau_x \tau_y \\ &\quad - \rho^{-2} \sum_x \tau_x \sum_y (\rho^{-2} + s^{-1} I_W - q \Delta_{\mathbb{Z}^d})_{x,y}^{-1} (qh + s^{-1} I_W \eta_y) \end{aligned} \quad (54)$$

Here we have dropped the parameters of the time zero measure q, ρ^2, h in order not to overburden the notation, however we have kept the time s in the notation.

The negative exponential of this Hamiltonian should give us the weight for the τ -configuration. Of course this expression is infinite because we just used a formal manipulation with infinite quantities. Let us make sense out of this by going through finite volumes in a suitable way, like we described in detail in Section 2 for the translation-invariant model.

Note that definition (54) is a generalization of the translation-invariant definition for the Ising Hamiltonian with resolvent interaction given by (20). With this notation we have in particular that $H^{\text{Ising}, W=\emptyset, s}(\tau) = H^{\text{Ising}}(\tau)$, and also $\lim_{s \uparrow \infty} H^{\text{Ising}, W, s}[\eta_W](\tau) = H^{\text{Ising}}(\tau)$.

Denote the specification corresponding to the Hamiltonian (54) by $\gamma_{\Lambda}^{\text{Ising}, W, s}[\eta_W](\tau_{\Lambda} | \tau_{\Lambda^c})$.

The first theorem says that putting random fields in a finite volume introduces only a finite energy change and so the construction of the infinite-volume Gibbs measures is reduced to the case without random fields. More precisely, it says the following.

Theorem 3.1. Fix any finite subset $W \subset \mathbb{Z}^d$, and configuration $\eta_W \in \mathbb{R}^W$.

Then the limit weak limit (w.r.t. product topology)

$$v^{W,s,+}[\eta_W] := \lim_{\Lambda \uparrow \mathbb{Z}^d} \gamma_{\Lambda}^{Ising,W,s}[\eta_W](\cdot | +_{\Lambda^c}) \tag{55}$$

exists and is absolutely continuous w.r.t. $v^+ = \lim_{\Lambda \uparrow \mathbb{Z}^d} \gamma_{\Lambda}^{Ising}(\cdot | +_{\Lambda^c})$. More precisely we have that

$$\int v^{W,s,+}[\eta](d\tau)\varphi(\tau) = \frac{\int v^+(d\tau)\varphi(\tau) \exp(-H^{Ising,W,s}[\eta_W](\tau) + H^{Ising}(\tau))}{\int v^+(d\tau) \exp(-H^{Ising,W,s}[\eta_W](\tau) + H^{Ising}(\tau))} \tag{56}$$

where

$$\tau \mapsto H^{Ising,W}[\eta_W](\tau) - H^{Ising}(\tau) \tag{57}$$

is a bounded continuous function (w.r.t product topology).

The measure (55) gives the relevant expectation over the τ -variables to control the conditional probabilities (51).

Proof. To see the continuity w.r.t. product topology of the difference Hamiltonian (57) we use the exponential decay of the resolvents appearing. E.g. for the terms that are quadratic in τ we write

$$\begin{aligned} & -\frac{\rho^{-4}}{2} \sum_{x,y} \left((\rho^{-2} + s^{-1}I_W - q\Delta_{\mathbb{Z}^d})_{x,y}^{-1} - (\rho^{-2} - q\Delta_{\mathbb{Z}^d})_{x,y}^{-1} \right) \tau_x \tau_y \\ & = \frac{\rho^{-4}}{2} \sum_{x,y} \left[(\rho^{-2} + s^{-1}I_W - q\Delta_{\mathbb{Z}^d})^{-1} s^{-1}I_W (\rho^{-2} - q\Delta_{\mathbb{Z}^d})^{-1} \right]_{x,y} \tau_x \tau_y \end{aligned} \tag{58}$$

It is clear now that the matrix elements $[\dots]_{x,y}$ decay exponentially in the distance of x and y from W . This shows the continuity of the quadratic part of the difference Hamiltonian in τ w.r.t. product topology because any variation w.r.t. τ outside of a large volume has a vanishing effect when this volume tends to the whole lattice. For the part of the Hamiltonian that is linear in τ the same argument applies.

The existence of (55) is clear by the continuity of (57). Indeed, it follows by re-expressing the expectation $\int \gamma_{\Lambda}^{Ising,W,s}[\eta_W](d\tau | +_{\Lambda^c})(d\tau)\varphi(\tau)$ for a local function $\varphi(\tau)$ in terms of an expectation w.r.t. $\int \gamma_{\Lambda}^{Ising}(d\tau | +_{\Lambda^c})(d\tau)\tilde{\varphi}(\tau, \eta_W)$ with a modified local function containing the difference Hamiltonian (57). So the existence of the limit $\Lambda \uparrow \mathbb{Z}^d$ of the first quantity follows by the existence of the latter, for all continuous $\tilde{\varphi}$. (Of course, in our case the existence of the limit is also granted by monotonicity.)

From this argument also the absolute continuity of the infinite-volume Gibbs measures (56) follows. □

Let us now give a reformulation for the single-site conditional probabilities (51), using the η -dependent discrete-spin states from the last theorem. The precise result is given in the next theorem. Remember the interpolating σ -configuration given by (53).

Theorem 3.2. *The finite-volume conditional expectations of the continuous time-evolved model can be written as an expectation w.r.t. a quenched discrete-spin Gibbs measure of a weakly discrete-spin dependent Gaussian in the form*

$$\mu_{q,\rho^2,h;s}^{+,BM}(d\eta_0|\eta_{V\setminus 0}) = \int v_{q,\rho^2,h}^{V\setminus 0,s,+}[\eta_{V\setminus 0}](d\tau_{\mathbb{Z}^d})$$

$$N\left[\left[\sigma_{\mathbb{Z}^d}^{W,s}[\eta_W](\tau_{\mathbb{Z}^d})\right]_0;\left[(\rho^{-2} + s^{-1}I_{V\setminus 0} - q\Delta_{\mathbb{Z}^d})^{-1}\right]_{0,0} + s\right](d\eta_0) \quad (59)$$

Proof. To show the equality we show that (remember (48))

$$\frac{\int v_{q,\rho^2,h}^+(d\tau) \int N\left[\sigma_{\mathbb{Z}^d}(\tau_{\mathbb{Z}^d}); (\rho^{-2} - q\Delta_{\mathbb{Z}^d})^{-1}\right](d\sigma) \prod_{x \in V\setminus 0} \frac{e^{-\frac{1}{2s}(\sigma_x - \eta_x)^2}}{\sqrt{2\pi s}} \times \varphi(\sigma_0)}{\int v_{q,\rho^2,h}^+(d\tau) \int N\left[\sigma_{\mathbb{Z}^d}(\tau_{\mathbb{Z}^d}); (\rho^{-2} - q\Delta_{\mathbb{Z}^d})^{-1}\right](d\sigma) \prod_{x \in V\setminus 0} \frac{e^{-\frac{1}{2s}(\sigma_x - \eta_x)^2}}{\sqrt{2\pi s}}}$$

$$= \int v^{V\setminus 0,s,+}[\eta_{V\setminus 0}](d\tau_{\mathbb{Z}^d})$$

$$\int N\left[\left[\sigma_{\mathbb{Z}^d}^{W,s}[\eta_W](\tau_{\mathbb{Z}^d})\right]_0;\left[(\rho^{-2} + s^{-1}I_{V\setminus 0} - q\Delta_{\mathbb{Z}^d})^{-1}\right]_{0,0}\right](d\sigma_0) \times \varphi(\sigma_0) \quad (60)$$

for all local bounded continuous $\varphi(\sigma_0)$.

Using Theorem 3.1 we replace the η -dependent discrete-spin measure on the r.h.s. and rewrite this equation as

$$\frac{\int v_{q,\rho^2,h}^+(d\tau) \int N\left[\sigma_{\mathbb{Z}^d}(\tau_{\mathbb{Z}^d}); (\rho^{-2} - q\Delta_{\mathbb{Z}^d})^{-1}\right](d\sigma) \prod_{x \in V\setminus 0} \frac{e^{-\frac{1}{2s}(\sigma_x - \eta_x)^2}}{\sqrt{2\pi s}} \times \varphi(\sigma_0)}{\int v_{q,\rho^2,h}^+(d\tau) \int N\left[\sigma_{\mathbb{Z}^d}(\tau_{\mathbb{Z}^d}); (\rho^{-2} - q\Delta_{\mathbb{Z}^d})^{-1}\right](d\sigma) \prod_{x \in V\setminus 0} \frac{e^{-\frac{1}{2s}(\sigma_x - \eta_x)^2}}{\sqrt{2\pi s}}}$$

$$= \frac{\int v_{q,\rho^2,h}^+(d\tau) \exp(-H^{\text{Ising},W,s}[\eta_W](\tau) + H^{\text{Ising}}(\tau))}{\int v_{q,\rho^2,h}^+(d\tau') \exp(-H^{\text{Ising},W,s}[\eta_W](\tau') + H^{\text{Ising}}(\tau'))}$$

$$\int N\left[\left[\sigma_{\mathbb{Z}^d}^{W,s}[\eta_W](\tau_{\mathbb{Z}^d})\right]_0;\left[(\rho^{-2} + s^{-1}I_{V\setminus 0} - q\Delta_{\mathbb{Z}^d})^{-1}\right]_{0,0}\right](d\sigma_0) \times \varphi(\sigma_0) \quad (61)$$

Since the l.h.s. and the r.h.s. describe probability averages over the local observable $\varphi(\sigma_0)$, the denominators providing the correct normalization constants, it suffices to show that

$$\int v_{q,\rho^2,h}^+(d\tau) \left(\int N\left[\sigma_{\mathbb{Z}^d}(\tau_{\mathbb{Z}^d}); (\rho^{-2} - q\Delta_{\mathbb{Z}^d})^{-1}\right](d\sigma) \right.$$

$$\left. \times \prod_{x \in V\setminus 0} \frac{e^{-\frac{1}{2s}(\sigma_x - \eta_x)^2}}{\sqrt{2\pi s}} \times \varphi(\sigma_0) \right)$$

$$\begin{aligned}
 &= \int \nu_{q,\rho^2,h}^+(d\tau) \left(\text{Const} \exp \left(-H^{\text{Ising},W,s}[\eta_W](\tau) + H^{\text{Ising}}(\tau) \right) \right. \\
 &\quad \int N \left[\left[(\rho^{-2} + s^{-1} I_{V \setminus 0} - q \Delta_{\mathbb{Z}^d})^{-1} \right. \right. \\
 &\quad \quad \left. \left. \times (qh1 + \rho^{-2} \tau_{\mathbb{Z}^d} + s^{-1} \eta_{V \setminus 0}) \right]_0; \right. \\
 &\quad \left. \left[(\rho^{-2} + s^{-1} I_{V \setminus 0} - q \Delta_{\mathbb{Z}^d})^{-1} \right]_{0,0} \right] (d\sigma_0) \times \varphi(\sigma_0) \Big) \quad (62)
 \end{aligned}$$

with some φ -independent and τ -independent constant.

To see this is essentially a computation with quadratic forms. Indeed, (62) follows from the equation

$$\begin{aligned}
 &\frac{1}{2} \langle \sigma - \sigma(\tau), (\rho^{-2} - q \Delta_{\mathbb{Z}^d}) (\sigma - \sigma(\tau)) \rangle + \frac{1}{2s} \sigma_{V \setminus 0}^2 - \langle \sigma, I_{V \setminus 0} \eta \rangle \\
 &\quad - \left(\frac{1}{2} \langle \sigma - \sigma^{V \setminus 0}[\eta_{V \setminus 0}](\tau), (\rho^{-2} - q \Delta_{\mathbb{Z}^d} + s^{-1} I_{V \setminus 0}) \right. \\
 &\quad \quad \left. \times (\sigma - \sigma^{V \setminus 0}[\eta_{V \setminus 0}](\tau)) \right) \\
 &\quad \left. - H^{\text{Ising},W,s}[\eta_W](\tau) + H^{\text{Ising}}(\tau) \right) = \text{Const} \quad (63)
 \end{aligned}$$

and a finite-volume approximation for the massive Gaussian fields under the τ -integral in (62), like we were using in Chapter 2. □

The nice representation given in (59) gives us control over the conditional probabilities of the time-evolved measure in terms of a model for discrete spins with ferromagnetic interaction. Moreover, the normal distribution appearing under the discrete integral in (59) has τ -independent variance. Its expectation is a strictly increasing function in τ . Therefore the problem of continuity the conditional probabilities of the time-evolved measure is boiled down to the investigation of the measure $\nu_{q,\rho^2,h}^{V \setminus 0,s,+}[\eta_{V \setminus 0}]$ as a function of η in growing volumes V . We immediately have the following result.

Theorem 3.3. *The time-evolved measure $\mu_{q,\rho^2,h,s}^{+,BM}(d\eta)$ is Gibbs in the sense of Definition 1.2 (see the Introduction) if and only if the following is true:*

For all sites $x \in \mathbb{Z}^d$ and for all continuous-spin ('random field'-) configurations η , for all $0 < M < \infty$, and for all $\varepsilon > 0$ there exists a volume $V_0 \ni x$ such that we have that

$$\begin{aligned}
 &\sup_{V:V \supset V_0} \sup_{\substack{\omega^+,\omega^-: \\ \omega^+,\omega^- \in [-M,M]^{\mathbb{Z}^d}}} \\
 &\quad \times \left| \nu_{q,\rho^2,h}^{V \setminus x,s,+}[\eta_{V_0 \setminus x} \omega_{V \setminus V_0}^+](\tau_x = +) - \nu_{q,\rho^2,h}^{V \setminus x,s,+}[\eta_{V_0 \setminus x} \omega_{V \setminus V_0}^-](\tau_x = +) \right| < \varepsilon \quad (64)
 \end{aligned}$$

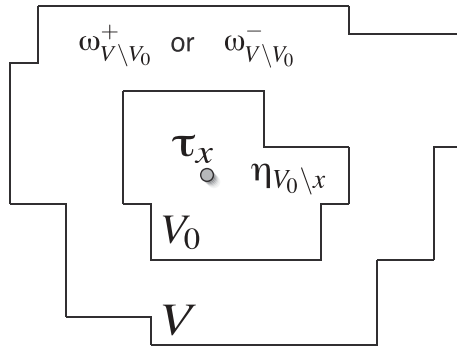

A random field configuration η is perturbed outside the volume V_0 .

4. Proof of main result

4.1. Proof of Theorem 1.3 (0)

We need to ensure the hypothesis of Theorem 3.3 on the random field-dependence of the local magnetization in the discrete-spin measures. For these we will prove the following precise and surprisingly simple estimate. It shows that a bounded variation of the random field configuration only has an influence on a local observable that is exponentially small in the distance between the support of this observable and the set where this variation takes place. The estimate is uniform in the time, and holds as long as the initial measure satisfies the criterion ensuring Dobrushin uniqueness, stated in the hypothesis of Theorem 1.3 (0).

We have the following theorem.

Theorem 4.1. *Consider the model (54), in any external magnetic field h . Recall the definition of the natural parameters $a_0 > 0$ and $\lambda > 0$ and suppose that $a_0 < a_0^*(\lambda)$.*

Then the model (54) is in the Dobrushin-uniqueness regime, with a bound on the Dobrushin constant that is uniform for any time s and any subset V .

Moreover we have the exponential bound

$$\begin{aligned} & \left| v_{q,\rho^2,h}^{V \setminus 0,s,+}[\eta_{V \setminus 0}](\tau_x = +) - v_{q,\rho^2,h}^{V \setminus 0,s,+}[\eta'_{V \setminus 0}](\tau_x = +) \right| \\ & \leq \frac{\rho^2 a_0}{2s} \sum_{z \in V \setminus 0} \left(I - \lambda(1 + a_0)\partial \right)_{x,z}^{-1} |\eta_z - \eta'_z| \end{aligned} \tag{65}$$

Remark 1. The condition $a_0 < a_0^*(\lambda)$ is equivalent to $\lambda(1 + a_0)2d < 1$ which implies exponential decay of the matrix elements of $\left(I - \lambda(1 + a_0)\partial \right)^{-1}$ in their distance.

Remark 2. Note that the bound diverges with $s \downarrow 0$. This is an artefact of the estimate. To improve on in for the case of small s we may apply the somewhat more complicated estimate given in the next subsection.

Proof. The proof is based on Dobrushin-uniqueness. We have for the single-site local specification of the quenched model

$$\gamma_x^{\text{Ising}, W, s}[\eta_W](\tau_x | \tau_{x^c}) = \frac{\exp\left(\tau_x \sum_y (\rho^{-2} + s^{-1}I_W - q\Delta_{\mathbb{Z}^d})_{x,y}^{-1}(\rho^{-4}\tau_y + \rho^{-2}(qh + s^{-1}I_{y \in W}\eta_y))\right)}{\text{Norm}} \tag{66}$$

Let us denote the corresponding Dobrushin interaction matrix by $C_{x,y}^{W,s}$. Recall (46,47). Using the fact that $(\rho^{-2} + s^{-1}I_W - q\Delta_{\mathbb{Z}^d})_{x,y}^{-1} \leq (\rho^{-2} - q\Delta_{\mathbb{Z}^d})_{x,y}^{-1}$ we get, along with the estimates for the Dobrushin interaction matrix from the translation-invariant case the same estimate

$$C_{x,y}^{W,s} \leq a_0 \sum_{n=1}^{\infty} \lambda^n (\partial^n)_{x,y} = a_0 \left(\frac{\lambda \partial}{1 - \lambda \partial} \right)_{x,y} \tag{67}$$

where a_0, λ were defined in (42).

To estimate the influence of the ‘random fields’ on the quenched measure we apply a general estimate on the change of the measure under change of the specification in the Dobrushin regime.

This estimate relies on the following piece of information (see [Geo88], Theorem 8.20).

Fact about Dobrushin uniqueness: Suppose that the random variables $(X_x)_{x \in \mathbb{Z}^d}$ are distributed according to a Gibbs measure ρ for a specification γ that obeys the Dobrushin uniqueness condition. Put $D = \sum_{n=0}^{\infty} C^n$ where C is the interdependence matrix of γ . Suppose that we are given another Gibbs measure $\tilde{\rho}$ such that the variational distance of the single-site conditional probabilities is uniformly bounded by

$$\sup_{\xi} \|\rho(\cdot | \xi) - \tilde{\rho}(\cdot | \xi)\|_x \leq b_x \tag{68}$$

with constants b_x for $x \in \Gamma$. Then the expectations of any function $f(\xi)$ on the infinite-volume configurations ξ don’t differ more than

$$|\rho(f) - \tilde{\rho}(f)| \leq \sum_{y,x \in \mathbb{Z}^d} \delta_y(f) D_{y,x} b_x \tag{69}$$

To apply this we note that in the course of the proof of Proposition 8.8 of [?] the following is shown. Suppose that $\lambda_x^{(i)}(d\omega_x) = e^{u^{(i)}(\omega_x)} \lambda(d\omega_x) / \int \lambda(d\tilde{\omega}_x) e^{u^{(i)}(\tilde{\omega}_x)}$, $i = 1, 2$ are two measures on the single-site space E , given in terms of the functions $u^{(i)}$. Then their variational distance can be bounded in terms of the variation of the function $u^{(1)} - u^{(2)}$ so that one has $\|\lambda_x^{(1)} - \lambda_x^{(2)}\|_x \leq \frac{1}{4} \sup_{\omega_x, \omega'_x} |u^{(1)}(\omega_x) - u^{(2)}(\omega_x) - u^{(1)}(\omega'_x) + u^{(2)}(\omega'_x)|$.

Applying this to the above local specification $\gamma_x^{\text{Ising}, W, s}[\eta_x | \eta_{x^c}]$ with random field configuration η_{x^c} resp. η'_{x^c} we thus get

$$\begin{aligned} b_x &\leq \frac{1}{2} \rho^{-2} s^{-1} \sum_{z \in W} (\rho^{-2} + s^{-1} I_W - q \Delta_{\mathbb{Z}^d})_{x,z}^{-1} |\eta_z - \eta'_z| \\ &\leq \frac{1}{2} \rho^{-2} s^{-1} \sum_{z \in W} (\rho^{-2} - q \Delta_{\mathbb{Z}^d})_{x,z}^{-1} |\eta_z - \eta'_z| \\ &\leq \frac{\rho^2 a_0}{2s} \sum_{z \in W} \left(\frac{I}{I - \lambda \partial} \right)_{x,z} |\eta_z - \eta'_z| \end{aligned} \tag{70}$$

Then we note that we can bound the positive matrix $D = (I - C)^{-1}$ by the element-wise estimate

$$D \leq \left(I - a_0 \frac{\lambda \partial}{1 - \lambda \partial} \right)^{-1} = \frac{I - \lambda \partial}{I - \lambda(1 + a_0) \partial} \tag{71}$$

The combination of (69), (70), (71) gives the desired estimate (65). Note that a cancellation in the matrix multiplication makes the structure of the bound particularly nice. \square

4.2. Proof of Theorem 1.3 (i)

Next we focus on the case of small s , but arbitrary initial measure. Of course we have in mind also the case of phase transitions in the initial model.

There is now a subtlety in the argument because the measures corresponding to the infinite-volume random field Hamiltonian (54) will not be in the Dobrushin regime any more. This is because the suppression of the couplings for small s acts only in the finite set W instead of in all of \mathbb{Z}^d . Let us therefore introduce the following artificial model that will be used as a comparison model in the ‘Fact’.

$$\begin{aligned} &\gamma_x^{\text{Ising}, W, s}[\eta_W] (\tau_x | \tau_{x^c}) \\ &= \frac{\exp\left(\tau_x \sum_y \left[(\rho^{-2} + s^{-1} - q \Delta_{\mathbb{Z}^d})_{x,y}^{-1} \rho^{-4} \tau_y + (\rho^{-2} + s^{-1} I_W - q \Delta_{\mathbb{Z}^d})_{x,y}^{-1} \rho^{-2} (q h + s^{-1} I_{y \in W} \eta_y) \right]\right)}{\text{Norm}} \end{aligned} \tag{72}$$

Here we have simply changed the interaction-part by definition, replacing the term $s^{-1} I_W$ by s^{-1} everywhere. The advantage of the above specification is that, for small enough s (depending on q, ρ^2) we are again in the Dobrushin-uniqueness regime. Indeed, note that in (72) the coupling between the τ -variables in the whole lattice disappears when s tends to zero.

On the other hand, the reason why this replacement is fruitful is that for x sufficiently far away from W^c , the interaction to the other τ_y is practically unchanged.

Let us introduce the natural s -dependent parameters

$$a_0(s) = \frac{1}{\rho^2(1 + 2dq\rho^2 + s^{-1}\rho^2)}, \quad \lambda(s) = \frac{q\rho^2}{1 + 2dq\rho^2 + s^{-1}\rho^2} \in [0, \frac{1}{2d}) \tag{73}$$

Let us denote the Dobrushin interaction matrix corresponding to this specification by $\bar{C}_{x,y}(s)$. We get with the usual arguments from the geometric series expansion for the interaction term the bound

$$\bar{C}_{x,y}(s) \leq a_0(s) \sum_{n=1}^{\infty} \lambda(s)^n (\partial^n)_{x,y} = a_0(s) \left(\frac{\lambda(s)\partial}{1 - \lambda(s)\partial} \right)_{x,y} \tag{74}$$

The corresponding Dobrushin constant $\bar{c}(s)$ then has a bound

$$\bar{c}(s) \leq a_0(s) \frac{\lambda(s)2d}{1 - \lambda(s)2d} \tag{75}$$

Indeed, for s sufficiently small, meaning that $a_0(s) \leq a_0^*(\lambda(s))$, there is Dobrushin uniqueness for the auxiliary model and we will denote its unique Gibbs measure by $\bar{\nu}^{W,s}[\eta_W]$. Assuming Dobrushin-uniqueness for the auxiliary measure $\bar{\nu}^{W,s}[\eta_W]$ it is then completely analogous to what was just done in the previous subsection to estimate the influence of the measure under the change of random fields.

So, let us focus on the estimation of the difference between the true measure $\nu^{V \setminus \{0,s\} + [\eta_W]}$ and the auxiliary measure $\bar{\nu}^{W,s}[\eta_W]$. Then the continuity property for the true measure follows by an obvious $\varepsilon/3$ -argument.

To do the former, we must estimate the variational distance between the specifications $\bar{\gamma}_x^{-\text{Ising}, W, s}[\eta_W](\tau_x | \tau_{x^c})$ and $\gamma_x^{\text{Ising}, W, s}[\eta_W](\tau_x | \tau_{x^c})$. The difference is due to the change in the couplings, and not the random fields, and we get for the corresponding quantity

$$\begin{aligned} \bar{b}_x(W) &\leq \frac{1}{2} \rho^{-4} \sum_{z \in \mathbb{Z}^d \setminus x} \left| (\rho^{-2} + s^{-1} I_W - q \Delta_{\mathbb{Z}^d})_{x,z}^{-1} - (\rho^{-2} + s^{-1} - q \Delta_{\mathbb{Z}^d})_{x,z}^{-1} \right| \\ &= \frac{1}{2} \rho^{-4} s^{-1} \sum_{z \in \mathbb{Z}^d \setminus x} \left((\rho^{-2} + s^{-1} I_W - q \Delta_{\mathbb{Z}^d})^{-1} I_W (\rho^{-2} + s^{-1} - q \Delta_{\mathbb{Z}^d})^{-1} \right)_{x,z} \\ &\leq \frac{1}{2} \rho^{-4} s^{-1} \sum_{z \in W^c} (\rho^{-2} + s^{-1} I_W - q \Delta_{\mathbb{Z}^d})_{x,z}^{-1} (\rho^{-2} + s^{-1})^{-1} \\ &\leq \frac{1}{2\rho^2(s + \rho^2)} \sum_{z \in W^c} (\rho^{-2} - q \Delta_{\mathbb{Z}^d})_{x,z}^{-1} \\ &\leq \rho^{-4} \sum_{z \in W^c} (\rho^{-2} - q \Delta_{\mathbb{Z}^d})_{x,z}^{-1} \end{aligned} \tag{76}$$

The point is that for x very far away from W^c the quantity $\bar{b}_x(W)$ becomes very small. Note also that this bound is uniform in s .

Now the ‘Fact about Dobrushin uniqueness’ gives us the following. For the auxiliary measure $\bar{\nu}$ we have for $\bar{D}(s) = (I - \bar{C}(s))^{-1}$ the element-wise estimate

$$\bar{D}(s) \leq \frac{I - \lambda(s)\partial}{I - \lambda(s)(1 + a_0(s))\partial} \tag{77}$$

Recall that by a_0 and λ we denote the natural parameters of the model at time zero (not assuming Dobrushin uniqueness). Then we have

$$\begin{aligned} \sum_y \bar{D}_{x,y}(s) \bar{b}_y(W) &\leq a_0 \sum_{y \in W^c} \left(\frac{I - \lambda(s)\partial}{(I - \lambda(s)(1 + a_0(s)\partial))(I - \lambda\partial)} \right)_{x,y} \\ &\leq \text{Const } e^{-\text{const dist}(x, W^c)} \end{aligned} \tag{78}$$

as soon as $a_0(s) < a_0^*(\lambda(s))$.

So we also have

$$\left| \bar{v}_{q,\rho^2,h}^{V \setminus x, s, +} [\eta_{V \setminus x}](\tau_x = +) - \bar{v}_{q,\rho^2,h}^{V \setminus x, s} [\eta_{V \setminus x}](\tau_x = +) \right| \leq \text{Const } e^{-\text{const dist}(x, V^c)} \tag{79}$$

This estimate says that the difference between the probabilities to see a plus at x between the original measure involving the non-translation invariant resolvent containing the term $s^{-1}I_{V \setminus 0}$ and the bar-measure with translation-invariant couplings is exponentially bounded in the distance from x to the boundary of V .

Note that it is simple to get from (77) and (69) [confer (70)] the estimate

$$\begin{aligned} &\left| \bar{v}_{q,\rho^2,h}^{V \setminus 0, s} [\eta_{V \setminus 0}](\tau_x = +) - \bar{v}'_{q,\rho^2,h}^{V \setminus 0, s} [\eta'_{V \setminus 0}](\tau_x = +) \right| \\ &\leq \frac{\rho^2 a_0(s)}{2s} \sum_{z \in V \setminus 0} \left(I - \lambda(s)(1 + a_0(s)\partial) \right)_{x,z}^{-1} |\eta_z - \eta'_z| \end{aligned} \tag{80}$$

This is completely identical to the proof given in the previous subsection. But from here the proof of the statement of the theorem follows by the said $\varepsilon/3$ -argument.

Referring to Remark 2 after Theorem 4.1 we now note that $\lim_{s \downarrow 0} \frac{a_0(s)}{s} = \rho^{-4}$ which gives uniformity as s goes to zero, instead of the simpler bound given in Theorem 4.1 . □

4.3. Proof of Theorem 1.3 (ii)

Return to the Hamiltonian (54). We fix an obvious candidate for a bad configuration, putting $\eta_x^{\text{spec}} \equiv -qhs$. Next we consider bounded perturbations, chosen to be $\omega_x^\pm \equiv \rho^2(\pm K - qhs)$, with some positive constant K .

Rewriting the Hamiltonian for these specific magnetic fields we have

$$\begin{aligned} H^{\text{Ising}, V \setminus 0, s} [\eta_{V_0 \setminus 0}^{\text{spec}} \omega_{V \setminus V_0}^\pm](\tau) &= -\frac{\rho^{-4}}{2} \sum_{x,y} (\rho^{-2} + s^{-1}I_{V \setminus 0} - q\Delta_{\mathbb{Z}^d})_{x,y}^{-1} \tau_x \tau_y \\ &+ \sum_x \tau_x \left(\sum_{y \in \mathbb{Z}^d \setminus V_0} (\rho^{-2} + s^{-1}I_{V \setminus 0} - q\Delta_{\mathbb{Z}^d})_{x,y}^{-1} (\mp K 1_{y \in V \setminus V_0} + qh 1_{y \in \mathbb{Z}^d \setminus V}) \right) \end{aligned} \tag{81}$$

It will be convenient to be a little more general even and consider Hamiltonians of the form where we allow for a different set V in the definition of the coupling-terms and for the annulus where the magnetic field term is $\pm K$. Let us consider

$$\begin{aligned}
 & -\frac{\rho^{-4}}{2} \sum_{x,y} (\rho^{-2} + s^{-1} I_{V \setminus 0} - q \Delta_{\mathbb{Z}^d})_{x,y}^{-1} \tau_x \tau_y \\
 & + \sum_x \tau_x \left(\sum_{y \in \mathbb{Z}^d \setminus V_0} (\rho^{-2} + s^{-1} I_{V \setminus 0} - q \Delta_{\mathbb{Z}^d})_{x,y}^{-1} (\mp K 1_{y \in V_1 \setminus V_0} + qh 1_{y \in \mathbb{Z}^d \setminus V_1}) \right)
 \end{aligned} \tag{82}$$

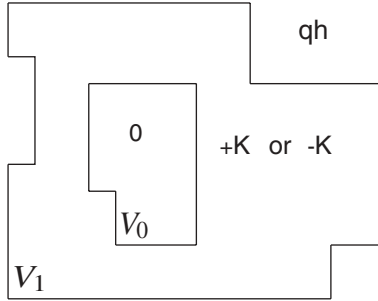

Let us comment on the structure of this Hamiltonian. For sites within V_0 , there is essentially no magnetic field and so the measure on such spins should be close to a (convex combination of) Gibbs measure(s) of a zero-field Ising model. The spins in the annulus $V_1 \setminus V_0$ feel a positive or negative magnetic field that can be made arbitrarily large by choosing K large. The spins even further outside in the region V_1^c won't be relevant any more when the annulus $V_1 \setminus V_0$ is chosen to be very large.

So it is intuitively clear that the distribution within the set V_0 will look like a plus state, for large V_0 and even larger V_1 , in the case of $-K 1_{y \in V_1 \setminus V_0}$. It will look like a minus state for $+K 1_{y \in V_1 \setminus V_0}$.

We will perform now a number of weak limits for the corresponding infinite-volume Gibbs measures.

Do be definite, (also in the case $h = 0$), define $\nu_1[\pm K, qh, V_0, V, V_1]$ to be the limit of the local specification with plus boundary conditions) corresponding to (82). We note that this limit exists, by monotonicity, and is a Gibbs measure for the above Hamiltonian (82).

Let us next assume that $K \neq qh$. Let us keep V fixed in (82) where it appears only in the coupling-term. Then we put $\nu_2[\pm K, V_0, V] = \lim_{V_1 \uparrow \mathbb{Z}^d} \nu_1[\pm K, qh, V_0, V, V_1]$. By monotonicity of the Hamiltonian in V_1 , also this limit exists and is a Gibbs measure for the Hamiltonian

$$\begin{aligned}
 & -\frac{\rho^{-4}}{2} \sum_{x,y} (\rho^{-2} + s^{-1} I_{V \setminus 0} - q \Delta_{\mathbb{Z}^d})_{x,y}^{-1} \tau_x \tau_y \\
 & \mp \sum_x K \tau_x \sum_{y \in \mathbb{Z}^d \setminus V_0} (\rho^{-2} + s^{-1} I_{V \setminus 0} - q \Delta_{\mathbb{Z}^d})_{x,y}^{-1}
 \end{aligned} \tag{83}$$

Let us denote by $\nu_{2,\Lambda}^+[\pm K, V_0, V]$ the finite-volume Gibbs measure corresponding to the Hamiltonian (83) in finite volume Λ , with plus boundary condition. We use a similar notation for minus boundary conditions with the same Hamiltonian.

For $K > 0$ sufficiently large (large field region) it is a simple exercise to see that Hamiltonian (83) obeys the Dobrushin uniqueness condition and so the resulting Gibbs measure is unique.

It now suffices to show (cf. Theorem 3.3) that in that regime of values of K we have

$$\nu_2[+K, V_0, V](\tau_x = 1) - \nu_2[-K, V_0, V](\tau_x = 1) > \delta \quad (84)$$

for some $\delta > 0$, uniformly in V_0 .

For any finite Λ we have the inequalities

$$\nu_{2,\Lambda}^+[+K, V_0, V] \geq \nu_{2,\Lambda}^+[0, V_0, V] \geq \nu_{2,\Lambda}^-[0, V_0, V] \geq \nu_{2,\Lambda}^-[-K, V_0, V] \quad (85)$$

From Theorem 2.4 it now follows easily that

$$\lim_{\Lambda \uparrow \mathbb{Z}^d} \nu_{2,\Lambda}^+[0, V_0, V](\tau_x = 1) - \lim_{\Lambda \uparrow \mathbb{Z}^d} \nu_{2,\Lambda}^-[0, V_0, V](\tau_x = 1) > \delta \quad (86)$$

uniformly in V_0, V . Indeed, there is no dependence on V_0 , for $K = 0$. Next we have the inequality

$$(\rho^{-2} + s^{-1} I_{V \setminus 0} - q \Delta_{\mathbb{Z}^d})_{x,y}^{-1} \geq (\bar{\rho}^{-2} - q \Delta_{\mathbb{Z}^d})_{x,y}^{-1} \quad (87)$$

where $\bar{\rho}$ on ρ are arbitrary close for s sufficiently large, uniformly in V . \square

References

1. Cattiaux, P., Røelly, S., Zessin, H.: Une approche Gibbsienne des diffusions Browniennes infini-dimensionnelles. *Probab. Theory Relat. Fields* **104**, 147–179 (1996)
2. Dai Pra, P., Røelly, S., Zessin, H.: A Gibbs variational principle in space-time for infinite-dimensional diffusions. *Probab. Theory Relat. Fields* **122**, 289–315 (2002)
3. Dai Pra, P., Røelly, S.: An existence result for infinite-dimensional Brownian diffusions with non-regular and non-Markovian drift. *Markov Proc. Rel. Fields* **10**, 113–136 (2004)
4. Dereudre, D., Røelly, S.: On Gibbsianness of infinite-dimensional diffusions. *Markov Proc. Rel. Fields* **10**, 395–410 (2004)
5. Dereudre, D., Røelly, S.: Propagation of Gibbsianness for infinite-dimensional Brownian diffusions. In preparation
6. Deuschel, J.D.: Infinite-dimensional diffusion processes as Gibbs measures on $C[0, 1]^{\mathbb{Z}^d}$. *Probab. Theory Relat. Fields* **76**, 325–340 (1987)
7. Doss, H., Royer, G.: Processus de diffusion associé aux mesures de Gibbs. *Z. Wahrsch. Verw. Geb.* **46**, 125–158 (1978)
8. van Enter, A.C.D., Fernández, R., den Hollander, F., Redig, F.: Possible loss and recovery of Gibbsianness during the stochastic evolution of Gibbs measures. *Commun. Math. Phys.* **226**, 101–130 (2002)
9. Georgii, H.-O.: *Gibbs Measures and Phase Transitions*. de Gruyter, New York, 1988
10. Griffiths, R.B., Pearce, P.A.: Position-space renormalization-group transformations: Some proofs and some problems. *Phys. Rev. Lett.* **41**, 917–920 (1978)

11. Külske, C.: The continuous-spin random field model: Ferromagnetic ordering in $d \geq 3$. *Rev. Math. Phys.* **11**, 1269–1314 (1999)
12. Külske, C., Le Ny, A.: Gibbs properties of mean-field models under time evolution. In preparation
13. Le Ny, A., Redig, F.: Short time conservation of Gibbsianness under local stochastic evolutions. *J. Stat. Phys.* **109** (5–6), 1073–1090 (2002)
14. Minlos, R.A., Røelly, S., Zessin, H.: Gibbs states on space-time. *Potential Analysis* **13**, 367–408 (2000)