

Malaysian Polymer Journal, Vol. 5, No. 2, p 1-36, 2010
Available online at www.fkkksa.utm.my/mpj



Recent Development of Polymer Electrolyte Membranes for Direct Methanol Fuel Cell Application – A Review

M. H. D. Othman, A. F. Ismail*, A. Mustafa

Advanced Membrane Technology Research Center (AMTEC),
Universiti Teknologi Malaysia, 81310 Johor Bahru, Johor, Malaysia

ABSTRACT: Direct methanol fuel cell (DMFC) system has tremendous potential to be developed as energy converters due to the simplicity and low temperature of its operation. However, the weaknesses of commercial polymer electrolyte membrane of the cell, perfluorinated ionomer (PFI) membrane, such as methanol crossover, limited operating temperature, susceptibility to osmotic swelling and high costs are among the factors hindering the commercialization of DMFC. This paper reviews a number of studies that have been recently performed in order to overcome the weaknesses. This review has classified the membrane development into three different branches, namely the modification of PFI membranes, the development of other fluoropolymer membranes, and the development of non-fluorinated polymers membranes.

Keywords: direct methanol fuel cell, polymer electrolyte membrane, perfluorinated ionomer, methanol crossover, non-fluorinated polymer

1. INTRODUCTION

Nowadays, direct methanol fuel cell (DMFC) is deemed as a potential option for energy converters, apart from proton exchange membrane fuel cell (PEMFC). In DMFC, methanol is fed directly to the cell without any fuel processing beforehand and as a result, DMFC does not require any fuel processing equipment. This leads to simplicity of operation in DMFC as compared to systems using a reformer to produce hydrogen from liquid fuel, i.e. indirect methanol fuel cell. Furthermore, methanol can be operated in the fuel cell system even at room temperature, compared to hydrogen, which operate at temperature higher than 80 °C. Although the technology behind DMFC is still at the early stages of development, it has been successfully demonstrated in powering mobile phones and other portable devices. The bright prospect of DMFC can also be foreseen in other applications such as transportation and power generation.

In a DMFC system as illustrated in Figure 1, methanol at the anode is oxidized to hydrogen ion (H⁺) and electron (e⁻) (Equation (1)). The electrons released flow through an electrical circuit that extends from the anode to the cathode. The hydrogen ions travel simultaneously to the cathode through the electrolyte membrane. At the cathode, the electron and hydrogen ion will react with oxygen to form water and release heat (Equation (2)).



*Corresponding author: A.F. Ismail, Email: afauzi@utm.my

Accordingly, the net cell reaction in a DMFC is the production of CO₂ and H₂O as,



The direct conversion of the chemical energy of reaction from CH₃OH into electrical energy is an advantage of DMFC compared to conventional combustor.

DMFC technology is similar to proton exchange membrane fuel cell (PEMFC), in which a polymer electrolyte membrane (PEM) is used as electrolyte. In DMFC operation, PEM plays three primary function roles, which are [1]:

- (1) as an ion conductor between anode and cathode;
- (2) as a separator for the fuel (methanol) and oxidant (oxygen or air), and
- (3) as an insulator between the cathode and anode so that electrons conduct through an electronic circuit and not directly through the membrane.

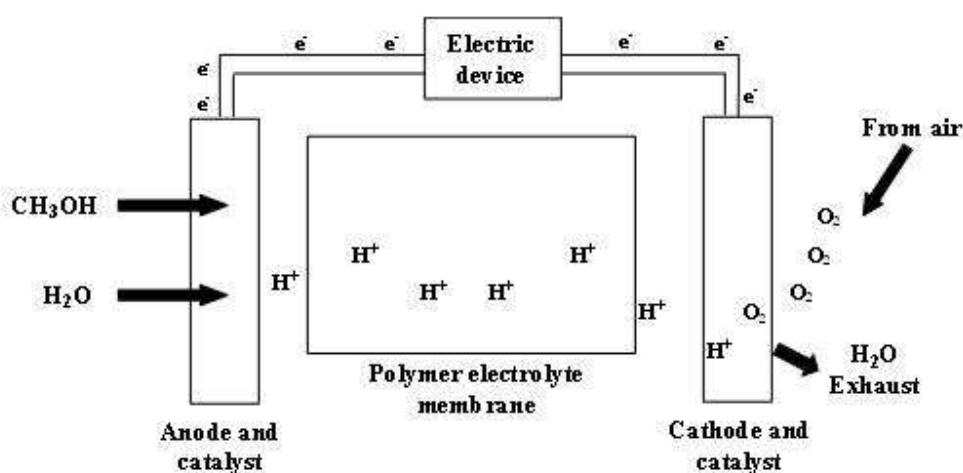

Figure 1: Schematic of direct methanol fuel cell system

PEM has been found to possess several desired properties such as chemical and electrochemical stability, adequate mechanical strength, low permeability to reactant liquids/gases, and also high proton conductivity that warrant its usage in DMFC application.

Previous paper reviewed more on electrolyte membrane for PEMFC [2-3]. However, in this paper, a review on current DMFC's electrolyte membrane has been specifically done, where the literatures for the commercial DMFC's electrolyte membranes is presented in the first part. The emphasis is given on Nafion[®] membrane as it is the most frequently used membrane compared to other PFI membranes. Then, in the second part, the recent developments of alternative polymer electrolyte membrane for direct methanol fuel cells (DMFC) application are reviewed in detail.

2. Commercial Polymer Electrolyte Membranes for Direct Methanol Fuel Cell System

The first PEM used in a fuel cell system was sulfonated polystyrene membrane. It was developed by General Electric for NASA in the early 1960s, as an on-board power source in the Apollo flight space mission [4]. However, this material was found to have several major weaknesses such as lack of stability and limited power density [5]. Since then, a number of studies have been conducted in order to discover a new PEM with better properties for fuel cell system. Later, in the middle of 1960s, two types of aliphatic perfluorinated ionomer (PFI) membranes, known as Nafion[®] and Flemion[®], were produced by Du Pont and Asahi Glass, respectively. After a couple of years, other PFI membranes like Aciplex[®] (Asahi Chemical), and Dow[®] (Dow Chemical), were discovered. To date, these PFI membranes are still practical for both PEMFC and DMFC, and currently remain as the only commercial membranes. The discussion on the characteristics of PFI membranes including their properties and limitations is covered in this topic.

2.1 The characteristics of perfluorinated ionomer (PFI) membranes

The fabrication processes of PFI membranes are as follows; the starting material of PFI is from polyethylene, as shown in Figure 2. This basic polymer is modified by substituting hydrogen by fluorine and is called polytetrafluoroethylene or PTFE. The modified polymer is also known as Teflon[®] [6]. Fluorine is chosen due to the small size and the high electronegativity of the fluorine atom and these features confer a strong C-F bond [5]. Chemically, the bond strength for C-F is about 485 kJ/mol, higher than that for C-H bonds (typically 350-435 kJ/mol) or C-C bonds (typically 350-410 kJ/mol) [7]. The strong bonds make it resistant to chemical attack and durable. Another important property is that, PTFE is strongly hydrophobic, and therefore, it is always used as electrodes for fuel cell, to drive the water product out of the electrode, and thus prevents flooding.

However, a further stage is needed to fabricate PFI membranes. The basic PTFE polymer is added with a perfluorinated side chain with sulfonic acid (SO₃H) group [6, 8]. The sulfonic acid group added is ionically bonded, and so the end of the side chain is actually an SO₃⁻ ion. For this reason, the resulting structure is called a "perfluorinated ionomer". Nafion[®] (DuPont), Aciplex[®] (Asahi Chemical), Flemion[®] (Asahi Glass), and Dow[®] (Dow Chemical) are examples of commercially available PFI membranes [9].

Among PFI membranes, Nafion[®] membrane, which has been developed through several modifications since the 1960s [10-11], is the most advanced commercially available PEM, and has become the preferred electrolyte material for both PEMFC and DMFC. Nafion[®] membrane is much cheaper than Dow[®] membrane, although the performance of Dow[®] membrane is superior, i.e. a fourfold increase in power density compared to the Nafion[®] 117 [12]. Furthermore, Nafion[®] has over 50,000 h lifetime which approximately 5 times longer than Dow[®] [5].

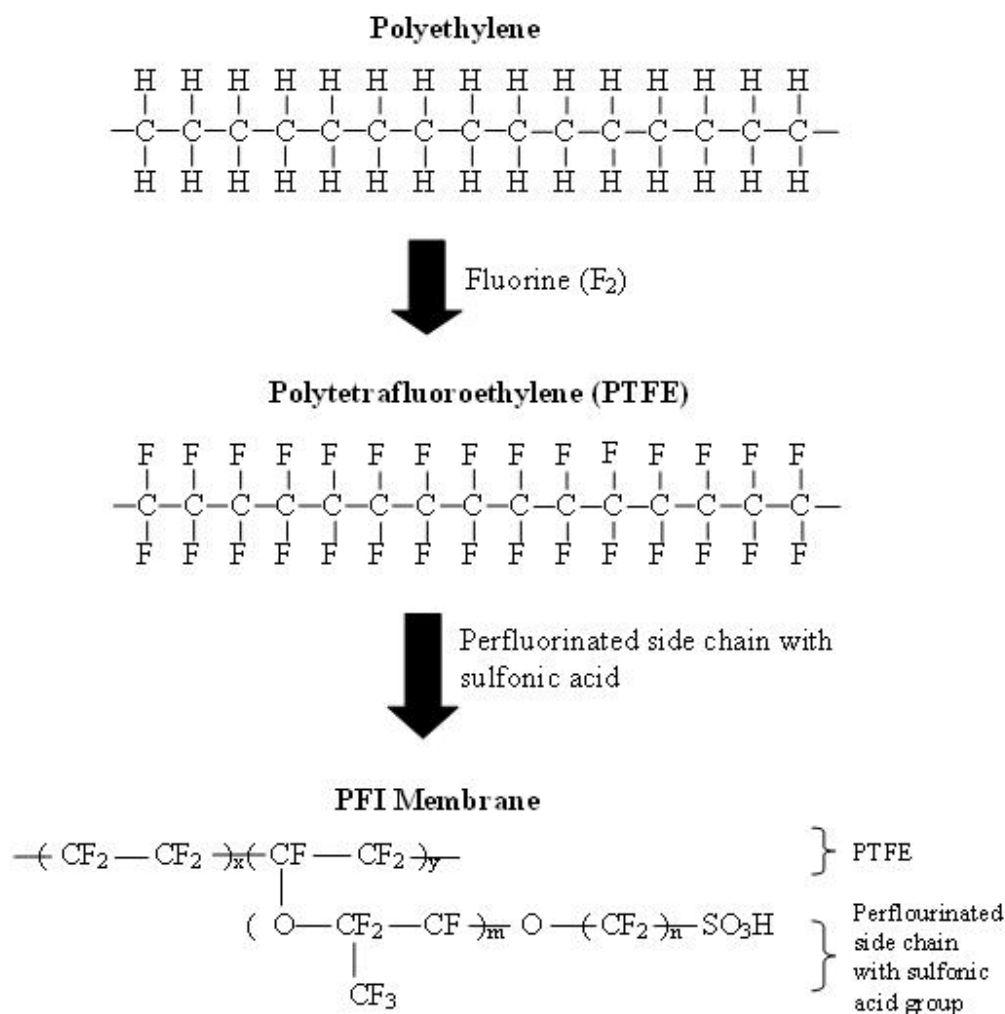

Figure 2: Fabrication step for Nafion[®], Flemion[®], Aciplex[®] and Dow[®] membranes

Nafion[®] membranes can be classified according to their thickness (Table 1). For example, Nafion[®] 117, 115 and 112 have thicknesses of 175 μm, 125 μm and 80 μm, respectively. Jung *et al.* [13] reported that the difference in thickness gives different performance in fuel cell operation when tested in an *active* DMFC system (require pump and fan to feed methanol and oxygen into a cell) operating at 110-130 °C. Their experiment also revealed that the cell performance increased with decreasing membrane thickness as a result of lower resistances. The similar result was also found by Liu *et al.* [14] for the performance of a *passive* DMFC system (require no pump or fan, and use the concentration gradient to deliver and circulate methanol and oxygen in the cell) at higher current densities as a thinner membrane exhibited better performance. However, the thinner membrane led to lower performance when the system was operated at lower current densities. Another study on the effect of thickness on membrane performance was carried out by Tsampas and co-workers [15].

Table 1: The properties of Nafion[®], Flemion[®], Aciplex[®] and Dow[®] membranes

Structure Parameter	Trade Name and Membrane Type	Equivalent Weight (EW)	Thickness (μm)
x = 5-13.5; y = 1; m = 1; n = 2	<i>DuPont</i>		
	Nafion [®] 120	1200	260
	Nafion [®] 117	1100	180
	Nafion [®] 115	1100	125
	Nafion [®] 112	1100	80
x = 1.5-14; m = 0; n = 2-5	<i>Asahi Chemical</i>		
	Aciplex [®] -S	1000-1200	25-100
m = 0, 1; n = 1-5	<i>Asahi Glass</i>		
	Flemion [®] -T	1000	120
	Flemion [®] -S	1000	80
	Flemion [®] -R	1000	50
x = 3.6-10; m = 0; n = 2	<i>Dow Chemical</i>		
	Dow [®]	800	125

* Structure parameters are referring to Figure 2

The hydrophobic and hydrophilic properties that come from the long chain molecules and the sulfonic acid (SO₃H) side chains, respectively, are the most interesting feature of Nafion[®] membranes. Two models that have been proposed to describe this feature, as illustrated in Figure 3. As depicted in Figure 3(a), the presence of this hydrophilic property produces a strong mutual attraction between the SO₃⁻ and H⁺ ions and increases the tendency of the side chain molecules to “cluster” within the overall structure of the material. This cluster network model as proposed by Hsu and Gierke [16] describes that the formation of spherical clusters (pores), which are connected by short narrow channels, is due to the separation of ion-exchange sites from the fluorocarbon backbone. When the membrane is dry, an average cluster has a radius of about 1.8 nm and it contains about 26 SO₃⁻ groups distributed on the inner pore surface. In the swollen state, the diameter increases to about 4 nm and the number of fixed SO₃⁻ groups goes up to about 70. Under these conditions, each pore is filled with about 1000 water molecules. Another Nafion[®] structure model, known as the three-region model, was proposed by Yeager and Steck [17]. This model distinguishes polymer backbone regions, proton conducting (aqueous) regions and narrow bridge-like transition regions connecting the larger aqueous regions as shown in Figure 3(b). Within the hydrated regions for both models, the H⁺ ions are relatively weakly attracted to the SO₃⁻ group and then move freely and enabling the membrane to transfer hydrogen ions, from one side (anode) of the membrane to the other side (cathode). Therefore, these hydrophilic and hydrophobic properties result in five important properties of the Nafion[®] material [6], which are high chemical resistant, mechanically strong, acidic, very absorptive to water, and also good proton conductors. For example Nafion[®] 117 exhibits 0.1 S/cm when it is measured at room temperature [18].

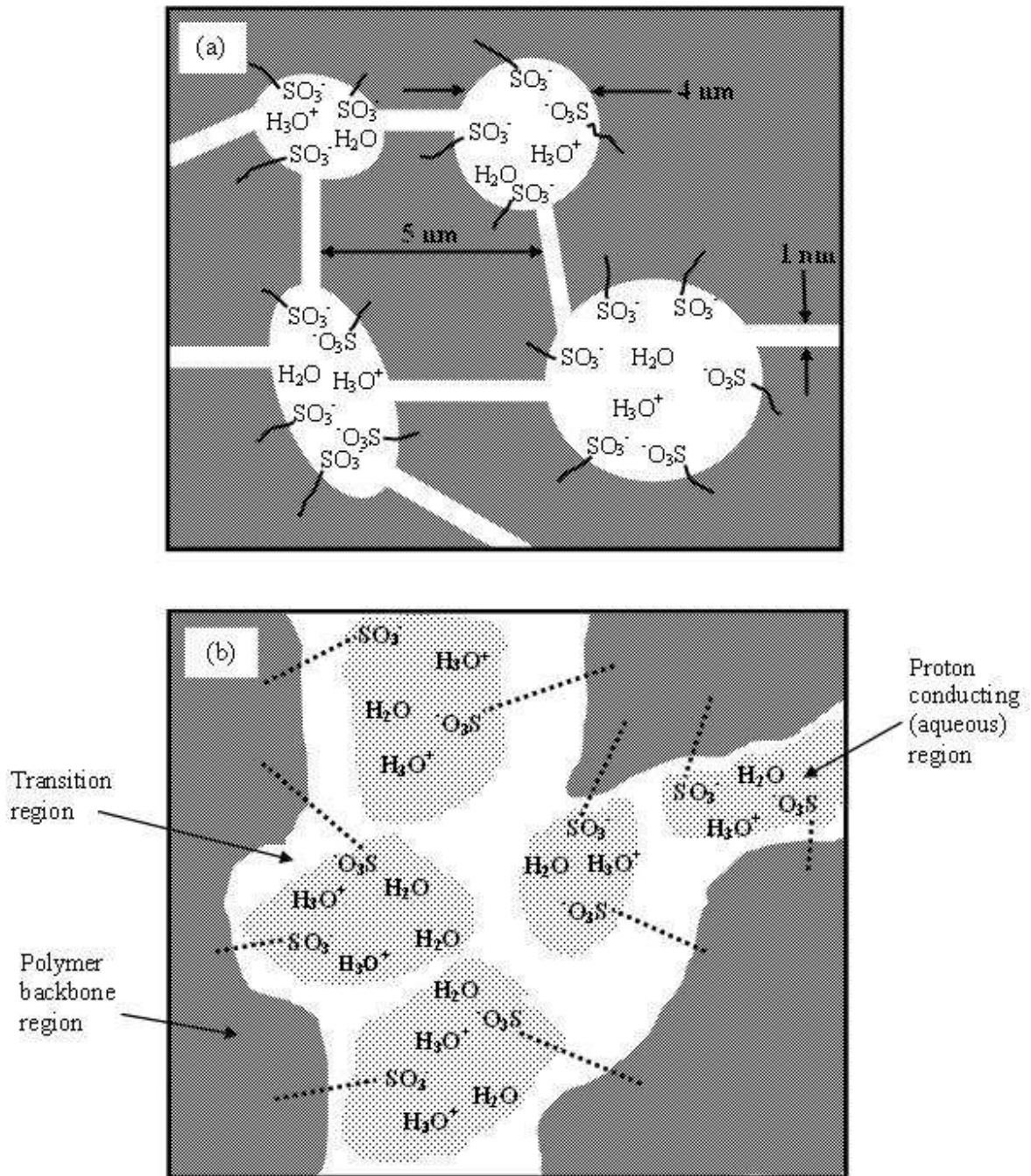

Figure 3: Hydrophobic/hydrophilic domains in Nafion[®] membrane; (a) Cluster network model, and (b) Three region model

2.2 Limitations of perfluorinated ionomer membranes

Despite showing an effective performance in PEMFC, the PFI membranes (especially Nafion[®]) have a variety of limitations that hamper the emergence of the DMFC design. One of the main drawbacks is methanol crossover through the membrane from anode to cathode. For example, high hydrophobicity perfluorinated backbone and high hydrophilicity of the sulfonic acid functional groups in Nafion[®] membranes would give rise to the formation of hydrophobic/hydrophilic domains, especially in the presence of water. According to the cluster network model, these hydrophilic domains formed by the sulfonic acid groups are interconnected in Nafion[®] membranes. Not only proton and water can transport through these domains, but a smaller polar molecule such as methanol can also permeate through these domains [19]. As a result, it leads to methanol crossover. The methanol crossover is a relevant problem since it has two bad effects to the cells. Firstly, the chemical energy of methanol is lost when it crosses through the membrane, thus severely lowering the efficiency of fuel utilization [20]. Secondly, as methanol arrives the other side of the PEM, it is oxidized by the cathodic electro-catalyst, which depolarizes the electrode and subsequently increases the amount of air or oxygen. Since none of the energy from this oxidation is extracted as electricity, it all ends up as waste heat that increases the cooling load on the cell [21].

Another Nafion[®] membrane drawback is related to its conductivity mechanism. Nafion[®] membrane conducts protons with the aid of water, but if it is not properly hydrated, proton conduction becomes slow. As highlighted in Table 2, at relative humidity 100 %, the membrane conductivity is 6.2×10^{-2} S/cm but it decreases drastically, more than a magnitude order of two at relative humidity 9 %. It means that membrane needs humidification in order to maintain or increase its conductivity characteristics. The level of humidification may vary depending on the operating temperature of the DMFC and it has been proven that this membrane could not sustain prolonged operation at temperatures higher than 130 °C due to dehydration phenomenon occurring at high temperature, with consequent lower conductivity and performance losses [22-23].

Table 2: Ionic conductivity of Nafion[®] [2]

Relative humidity (%)	Conductivity (S/cm)
100	6.2×10^{-2}
81	2.1×10^{-2}
58	8.0×10^{-3}
31	1.4×10^{-3}
9	1.1×10^{-4}

Nafion[®] is also very susceptible to osmotic swelling. There is a significant size difference between 0 % hydrated Nafion[®] and 100 % hydrated Nafion[®], and this feature is a determinative factor in the longevity and performance of a DMFC. This osmotic swelling is of particular note in the cycle times of DMFC that use Nafion[®]. If this fuel cell requires many cycle times for operation, it will deteriorates faster than if continually in operation. This is mainly due to the swelling and shrinking of Nafion[®] during DMFC cycles. Other than osmotic swelling problem, Nafion[®] membrane is also potentially dissolved in methanol solution. Siroma *et al.* [24] reported that the dissolved fractions of Nafion[®] membrane increased with increasing methanol concentration and temperature.

High production cost is other major drawback of Nafion[®]. Owing to its relatively complicated and time-consuming manufacturing process, Nafion[®] is very expensive and this affects significantly the cost of a DMFC, which represents from 10 to 15 % of the overall cost of the stack [1].

3. Recent Development of Alternative Polymer Electrolyte Membranes for Direct Methanol Fuel Cells Application

Before further reviewing the recent development of PEM in this section, it is good to know and understand the characterization methods that are usually implemented by PEM researchers to determine the performances of their membranes with respect to DMFC applications. There are several types of fundamental measurements such as water uptake, methanol permeability and proton conductivity. Water uptake measurement is used to determine the water content of the membranes through the difference of wet and dry membranes weight.

Diffusion [18, 25-27] and pervaporation techniques [28-30] have been found as the popular techniques among researchers to measure the methanol permeability of membranes. The first technique employs a diaphragm diffusion cell containing solutions of methanol-water mixture and water in two compartments separated by the test membranes. The concentration of methanol that diffuses through membranes will be estimated using differential refractometer or gas chromatography. Meanwhile, the latter technique also comprises of two compartments, one containing methanol solution which is known as the feed side, and the other side is evacuated, and is known as the permeate side. The permeate will be collected in a trap immersed in liquid nitrogen after certain time intervals. The amount of permeate will be weighed before the permeate concentration determined by differential refractometer or gas chromatography. The methanol permeability for both techniques will be calculated from the slope of a straight-line plot of methanol concentration versus permeation time.

Proton conductivity measurement is frequently performed using an impedance/gain-phase analyzer. The membrane to be tested will be placed between two electrodes connecting to the analyzer. The proton conductivity, σ (Siemens per centimeter (S/cm)), will be calculated from impedance data, using the relation $\sigma = l/RS$, where l and S are the thickness and area of the membrane, respectively, and R is derived from the low intersect of the high frequency semi-circle on a complex impedance plane with the $\text{Re}(z)$ axis, as depicted in Figure 4.

There are a number of studies that have been recently performed in order to overcome the weaknesses of commercial membrane as mentioned in the previous section. Three different pathways are established to achieve those purposes:

- a) the modification of Nafion[®] membranes;
- b) the development of other fluoropolymer membrane; and
- c) the development of non-fluorinated polymers and their composites.

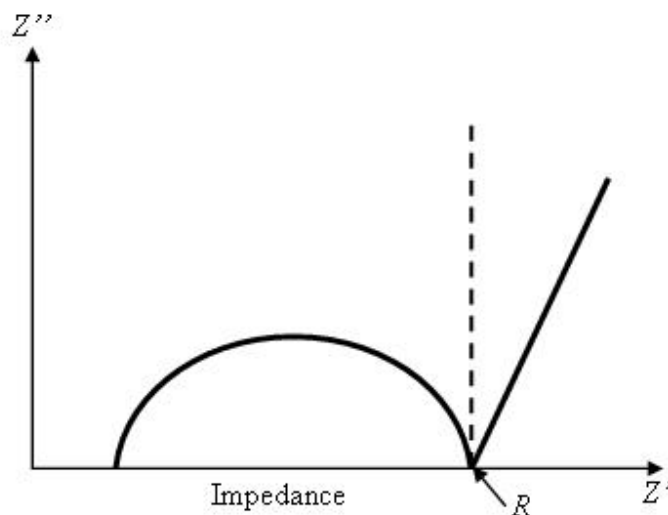

Figure 4. Impedance spectrum

3.1 The modification of Nafion[®] membranes

The modification efforts of Nafion[®] membrane have recently been focused on minimizing the methanol crossover, which is particularly serious in the DMFC system. One of the modifications is the depositing of thin plasma polymerized barrier films on Nafion[®] membrane in a low-pressure microwave generated plasma [31]. Two barrier films, hydrocarbon films deposited from a hexane plasma and fluorocarbon films deposited from a tetrafluoroethane ($C_2F_4H_2$) plasma, have been used in this study and both films showed very effective barrier layers to reduce the methanol permeability. These hydrocarbon films exhibit good barrier properties against methanol and other polar solvents. Jung *et al.* [23] investigated Nafion[®]/silicon composite membrane via the *in-situ* acid-catalyzed sol-gel reaction of tetraethylorthosilicate (TEOS). The experimental results showed that the modified Nafion[®] membrane had significant reduced the methanol permeability but at the same time detrimental to the membrane conductance.

Palladium (Pd) [32] was also used to modify Nafion[®] membrane by coating it with a different thickness of Pd film, using sputtering method. Scanning electron microscopy (SEM) micrographs in Figure 5 (a-c) showed that the 10 and 30 nm Pd film were dense and appeared to be well attached to the membrane. However, some cracks were found on the surface of the 100 nm Pd film. It was believed that the cracks were caused by the difference in expansion coefficient between Nafion[®] membrane and Pd film that took place when the composite membrane is immersed in water. From the findings, a trade-off between proton conductivity and methanol crossover is noted, similar to Nafion[®]/silicon oxide composite membrane results. The presence of Pd film not only diminishes methanol crossover, but also reduces the proton conductivity of the membrane. Ma *et al.* [33] reported that the addition of silver (Ag) into Pd improved the proton conductivity of Pd film as the Pd-Ag alloy film had higher proton conductivity than the pure palladium film. The presence of platinum on the membrane surface as illustrated in Figure 6 acted as a bridge to transfer proton from Pd-Ag film to Nafion[®] due to the different mechanism of proton transport between them.

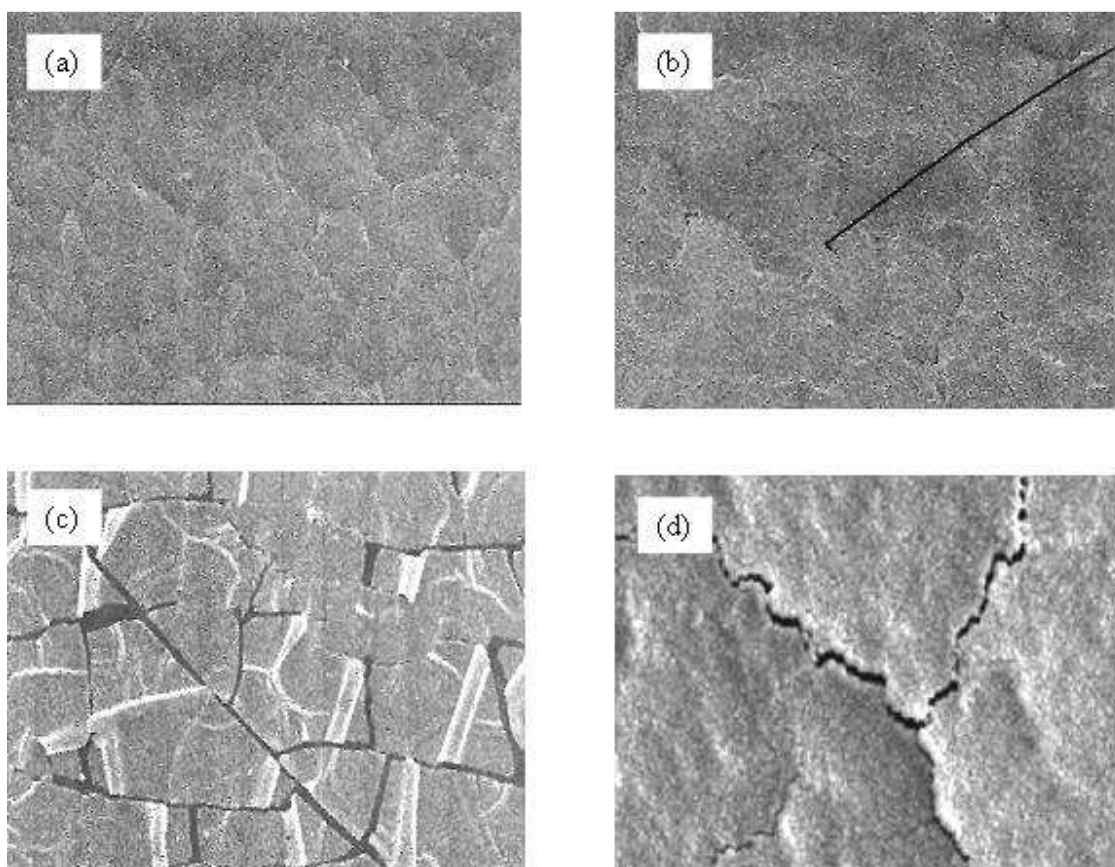

Figure 5: SEM micrographs of Pd and Pd/Ag sputtered Nafion[®] membranes; (a) 10 nm Pd film, (b) 30 nm Pd film, (c) 100 nm Pd film [32], and (d) 1000 nm Pd/Ag film [33]

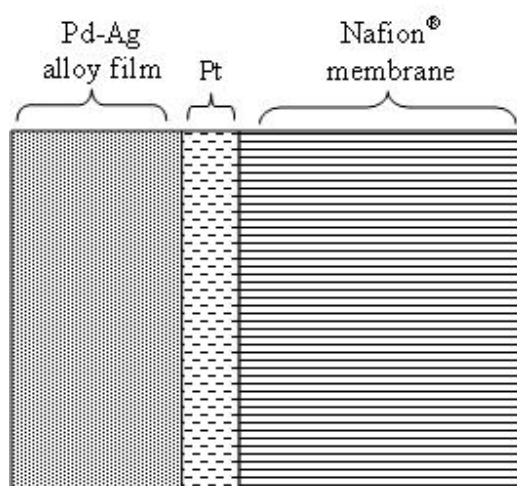

Figure 6: Illustration of Pd–Ag film deposited Nafion[®] membrane

Choi *et al.* [26] combined plasma-modification of the membrane surface and palladium-sputtering techniques in an attempt to reduce the methanol crossover problem. Three types of modified membranes, i.e. plasma-etched membrane, Pd-sputtered membrane, and plasma etched and Pd-sputtered membrane, were prepared and their permeability including unmodified Nafion[®] membranes, were measured in a diffusion cell. The graph of the methanol amount that crossed through the membrane and diffused on the other side of the compartment versus permeation time is shown in Figure 7. Then the methanol permeability was calculated from the straight-line slope of the above graph and listed in Table 3. Clearly, all modified membranes effectively reduced the methanol permeability. Nafion[®] with montmorillonite (MMT) and MMT containing dodecylamine (m-MMT) membranes were also developed [34] by melt intercalation method using internal mixer between Nafion[®] R-1100 resin, MMT and m-MMT.

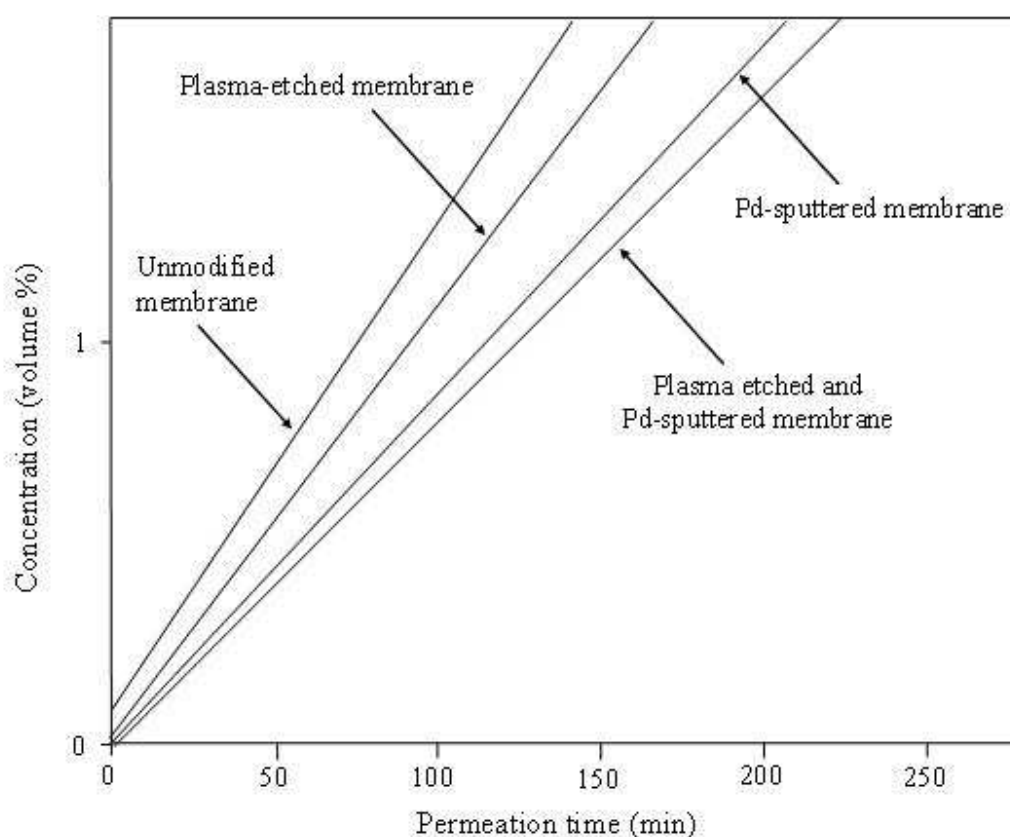

Figure 7: Concentration of permeated methanol as a function of time (Reproduced from [26])

Table 3: Methanol permeabilities of unmodified and modified membranes (at room

temperature) [26]

Type of membrane	Methanol permeability (cm ² /s)
Unmodified membrane	2.392 x 10 ⁻⁶
Plasma-etched membrane	2.106 x 10 ⁻⁶
Pd-sputtered membrane	1.700 x 10 ⁻⁶
Plasma etched and Pd-sputtered membrane	1.598 x 10 ⁻⁶

Several polymers such as polypyrrole [22] and polyvinyl alcohol (PVA) [35] have also been considered as the supporting materials for Nafion[®] membrane. Smit *et al.* [22] have synthesized a thin layer of polypyrrole inside the nanopores of the existing Nafion[®] membrane. Polypyrrole has the potential to reduce the methanol cross-over without detrimenting proton conductivity of membrane. For PVA, it was chosen as a modifying agent due to its capability to separate water from organic compounds like methanol. The modification approach of Nafion[®]/PVA composite membrane was almost similar to Nafion[®]/Pd and Nafion[®]/Pd-Ag composite membranes, which by coating technique [35]. The cell polarization test at 80 °C was used to evaluate membrane's relative selectivity, α , which is defined as the ratio of the multiplication of the methanol permeation current density, i_d , and area resistance, R , of the modified membrane to that the Nafion[®] membrane, as shown in Equation (4).

$$\alpha = \frac{R_N i_{dN}}{R_M i_{dM}} \quad (4)$$

where N and M refer to Nafion[®] and modified membranes, respectively.

The best results as summarized in Table 4 show that the modified membrane of 50:50 ratio exhibits the lowest methanol permeability as indicated by the highest relative selectivity. Table 5 shows that the performance of the 50:50 modified membrane can be further improved by sulfonation.

Table 4: Limiting methanol permeation current density, i_d and area resistance, R of Nafion[®] membrane coated with different PVA and Nafion[®] ratio (after one immersion treatment) [35]

Ratio of PVA to Nafion [®]	i_d at 80 °C (mA/cm ²)	R at 80 °C (μm^2)	Relative selectivity, α
10:90	288	0.65	1.04
25:75	261	0.70	1.07
50:50	238	0.74	1.11
85:15	111	1.89	0.93
100:0	93	2.42	0.87

Table 5. Effect of sulfonation on the modified Nafion[®] membrane by a cast film ratio of PVA to

Nafion[®] 50:50 (after two immersion treatment) [35]

Sulfonation step	i_d at 80 °C (mA/cm ²)	R at 80 °C (μm ²)	Relative selectivity, α
No	36	5.85	0.93
Yes	229	0.65	1.31

Apart from methanol crossover, Nafion[®] membrane also suffers from low proton conductivity when operating at high temperature due to dehydration phenomena. The inclusion of inorganic fillers inside the Nafion[®] membrane has been found as an alternative to enhance water retention of the membrane for operation temperature at above 100 °C. Several workers [36-39] prepared composite membrane solution by mixing Nafion[®] ionomer with inorganic fillers such as phosphotungstic acid-impregnated silicon dioxide (SiO₂/PWA), silicon dioxide (SiO₂) and alumina (b-Al₂O₃) powders. Figure 8 compares the water retention performance and it shows that the composite membranes exhibited higher retention capability in the high temperature range than the bare recast Nafion[®] membranes. In addition, zirconium phosphate (ZrP) was also reported as a promising filler in Nafion[®] membrane, due to the additional H⁺-ions of the phosphate-moiety and bound crystal water [40]. Bauer and Porada [40] examined the DMFC performance of ZrP-modified Nafion[®] membranes and found that the inorganic fraction slightly enhanced water content as compared to the untreated membrane. The permeation tests also showed that the inorganic compound reduced the methanol permeability.

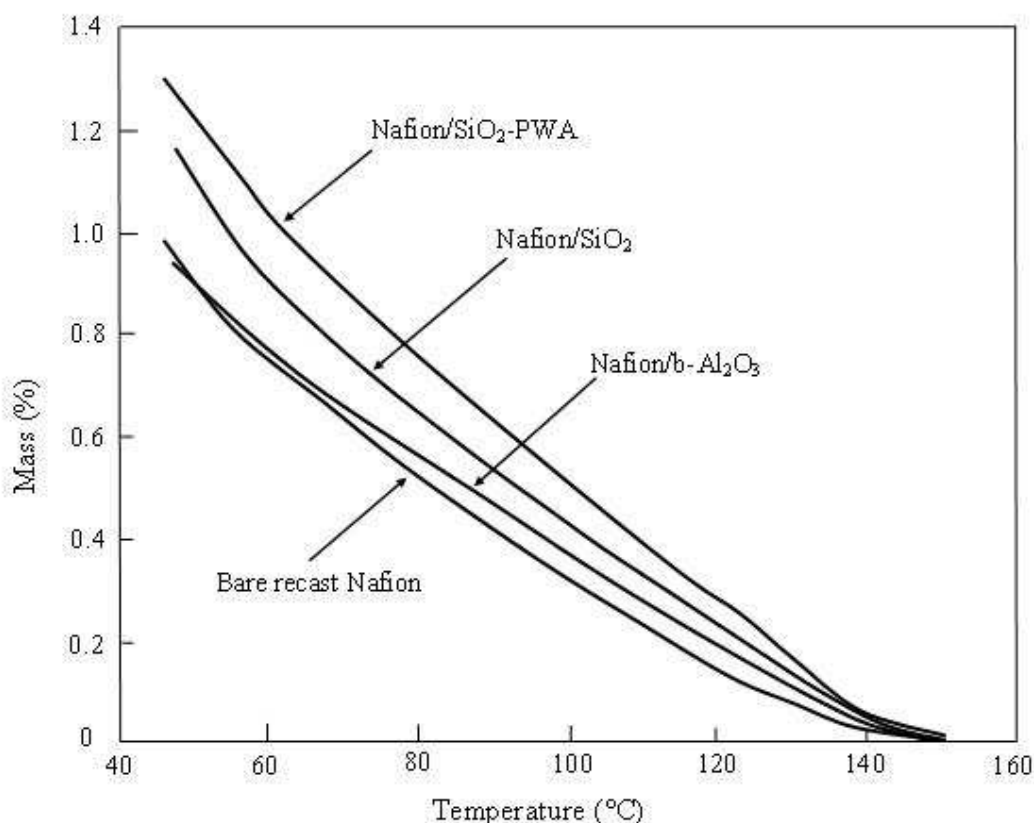

Figure 8: Thermogravimetric analysis of the water retention (Reproduced from [36])

3.2 The development of other fluorinated polymer membranes

Fuel cells research has nowadays been emphasizing on aromatic fluorinated polymers like α,β,β -trifluorostyrene (TFS) not only due to the high cost of PFI but also other fuel cell associated characteristics such as high mechanical and thermal stability, chemical inertness (to solvents, chemicals, acids and bases), good resistance to oxidation and very interesting surface properties [41].

The synthesis of TFS polymer involving several steps such as multiple-step synthetic route (required benzene, trihalogeno acid chloride and Lewis acid to catalyze the electrophilic aromatic substitution), chlorination and also halogen substitution was reported for the first time in 1949 by Cohen *et al.* [42]. Further improvements on the development of TFS production have been extensively studied by several researchers [43-50]. In addition to TFS production, efforts have also been made to co-polymerize THS. Prober [43] initiated polymerized TFS by several radical organic initiators and then co-polymerized TFS with styrene in the presence of potassium persulfate. Tevlina *et al.* [50] copolymerized TFS with vinyl fluoro monomers like *N*-vinylpyrrolidone, $H_2C=CF-CN$, $FHC=CF-COOMe$ and $F_2C=C(CF_3)-COOMe$ in the presence of azobisisobutyronitrile (AIBN).

There was renewed interest in co-polymerization of TFS in the middle of 1990s. Stone *et al.* [51] and Wei *et al.* [52] discovered that this polymer has the potential to be developed as an electrolyte membrane in fuel cell application and Ballard Advanced Materials Corporation (BAM) successfully patented co-polymerized TFS membrane under the registered name, BAM[®] membrane. Figure 9 shows the general formula of this membrane, where at least two of m , n , p , q are integers greater than zero and A_1 , A_2 , A_3 are selected from the group consisting alkyls, halogens, O-R (R is selected from the group consisting of alkyls, perfluoroalkyls and aryls), $CF=CF_2$, CN, NO_2 and OH. The A_1 , A_2 , A_3 substituents may be located in the ortho, meta and/or para positions [52]. The BAM[®] membrane possessed equivalent weights (EW) ranging from 735 to 407 $g\ mol^{-1}$ [12, 53]. Beattie and co-workers [53] found that the water content and conductivity of BAM[®] membrane are strongly dependent on the value of EW as shown in Table 6.

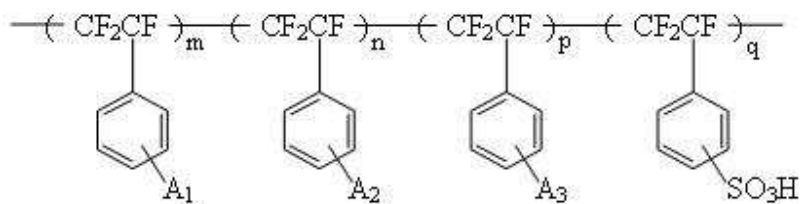

Figure 9: General chemical structure of BAM[®] membrane [12]

Table 6: Equivalent weight, water content and conductivity of BAM[®] membrane [53]

Equivalent weight (g mol ⁻¹)	Water content (wt.%)	Conductivity (S cm ⁻¹)
407	89.5	0.09
436	81.3	0.09
455	79.5	0.11
509	55.9	0.17
542	46.5	0.15
735	31.6	0.05

One of the best-known BAM[®] membranes is 3rd Generation Ballard Advanced Material (BAM3G). The structure of BAM3G membrane, as shown in Figure 10, consists of α,β,β -trifluorostyrene-*m*-CF₃- α,β,β -trifluorostyrene (TFS-*m*-CF₃-TFS). The BAM3G membrane has been demonstrated to have about 15 000 h of cumulated lifetime in commercially available Ballard Mark V single cell fuel cell [12] and Stone [52] also reported that the BAM3G membrane with EW of 427 and water content of 145 %, exhibited higher cell voltage than Nafion[®] 117 and Dow[®] membranes.

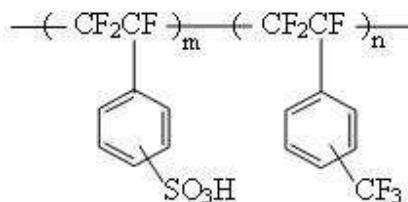

Figure 10: The structure of BAM3G membrane [52]

Other than TFS, polytetrafluoroethylene (PTFE) is also categorized in the fluorinated polymer group. Although PTFE is highly hydrophobic and not suitable to be used as electrolyte membrane, a number of modifications have been done to this membrane to improve its properties. Among of the modifications were by dispersing zeolite in the PTFE matrix [54], by preparing a pore-filling type PEM using porous PTFE substrates with an acrylic acid-vinylsulfonic acid crosslinked gel [55], and also by crosslinking of PTFE films by electron-beam irradiation and used them as substrates for grafting of two alkyl vinyl ether monomers, propyl vinyl ether (*n*PVE) and isopropyl vinyl ether (*i*PVE), followed by sulfonation reactions [56].

Poly(ethylene-*alt*-tetrafluoroethylene) (ETFE) is another fluorinated polymer of a special position among fluorinated polymers as it contains alternating structural units of polyethylene (PE) and PTFE that confers it a unique combination of properties imparted from both fluorinated resin and hydrocarbon resin. For instance, ETFE is less dense, tougher, stiffer and higher mechanical strength than fully fluorinated polymer, i.e. PTFE. It also offers an excellent thermal stability and superior resistance to common solvents. Efforts to modify ETFE are aimed at improving the selectivity and chemical stability of this membrane. By graft-copolymerizing of four styrene derivative monomers, *m,p*-methylstyrene (MeSt), *p-tert*-butylstyrene (*t*BuSt), divinylbenzene (DVB) and bis(*p,p*-vinyl phenyl) ethane (BVPE) into

ETFE films, followed by sulfonation and hydrolysis [57], the newly membrane possesses significantly higher chemical stability than the traditional styrene/DVB-grafted membrane and six times lower methanol permeability compared to the Nafion[®] 112 membrane. ETFE was also grafted with polystyrene sulfonic acid (PSSA) [58] as proton-conducting groups and this modified ETFE membrane could provide an attractive alternative to the expensive Nafion[®] membrane for DMFC application.

Other studies of fluorinated polymer for DMFC application were conducted by Nasef *et al.* [59] and Nasef *et al.* [60] when they pore filling of porous poly(vinylidene fluoride) (PVDF) films with PSSA using radiation-induced grafting. The experimental result exhibits the proton conductivity of the membrane exceeds that of the Nafion[®] 117 membrane, at a grafting yield of 46 % and the methanol permeabilities of 40 and 46 % pore-filled membranes are lower than that of Nafion[®] 117 by 53 and 71 %, respectively. This result suggests that PVDF membrane is also potential candidate as DMFC's electrolyte membrane, beside TFS, PTFE and ETFE.

3.3 The development of non-fluorinated polymers and their composites

Various polymer materials without fluorine compound in their chain have also been developed in order to overcome the limitation of PFI membrane. A number of non-fluorinated polymer membranes will be discussed in this part, stressing on their molecular structures and performance as PEM for DMFC. Some of the literatures about the composite polymer with other materials like inorganic compound, additive or other polymer, or the so-called composite membrane, are included.

3.3.1 Homo polymer membrane of non-fluorinated polymer

These non-fluorinated polymer membranes can be differentiated into two categories based on their proton conduction mechanisms. The first category involves water molecules, where sulfonated polysulfone (SPSf) and sulfonated poly (ether ether ketone) (SPEEK) are included into this category since they need humidification to maintain or increase the conductivity characteristics. Some other electrolytes like polybenzimidazole (PBI), which do not necessarily involve water molecules in the mechanism of proton conduction, are classified into the second category. The general structure, proton conduction mechanism, and performances (proton conductivity and methanol permeability at room temperature) of the most non-fluorinated polymers for DMFC are summarized in Table 7.

a) Sulfonated polyimides

Sulfonated polyimides (SPI) can be synthesized from 1,4,5,8-naphthalenetetracarboxylic dianhydride (NTDA) [18] with different types of sulfonated diamines such as 2,20-benzidinedisulfonic acid (BDSA) [18, 70-71], 4,4'-diaminodiphenyl ether-2,2'-disulfonic acid (ODADS) [72], 9,9-bis(4-aminophenyl)fluorene-2,7-disulfonic acid (BAPFDS) [73], 4,4'-bis(4-sulfophenoxy)biphenyl-3,3'-disulfonic acid (BAPBDS) [74, 75], and 3-(2',4'-diaminophenoxy) propane sulfonic acid (DAPPS) [76]. One of the possible structures that can be produced through these syntheses is shown in Table 7, which was prepared from BTDA and BDSA. This structure is categorized in the main-chain-type where the sulfonic acid groups are directly bonded to the polymer backbone. Another one is the side-chain-type where sulfonic acid groups are attached to the side chains. The typical example of this type is SPI derived from NTDA and BSPBs. Both types of SPI have the potential to be promising alternatives for DMFC electrolyte because they exhibited good performances in DMFC measurements. These have been experimentally proven by Woo *et al.* [18] and Okamoto *et*

al. [75] when they respectively prepared main-chain-type and side-chain-type of SPI and found that the SPI membrane exhibited high proton conductivity and extremely low methanol permeability. Furthermore, Woo *et al.* [18] also reported that polyimide was thermally stable, mechanically strong and chemically resistant.

b) Sulfonated polystyrene

Polystyrene sulfonic acid (PSSA) can be synthesized using two techniques. The first technique involves sulfonation process using sulfonation agent like sulfuric acid [25]. Through this technique, the sulfonic acid groups will directly attach to the phenyl ring of the base polymer. In another technique known as radiation-induced grafting, a side chain containing sulfonic acid groups will be grafted onto the main polymer [77]. Caretta *et al.* [25] reported that the sulfonation technique offers a number of important advantages compared to the radiation-induced technique. Since the reaction is carried out in a homogeneous liquid phase, the product is homogeneously sulfonated. Moreover, this procedure is more prone than radiation-grafting to be implemented in a large-scale process. In terms of membrane performances, they discovered that the membranes cast from sulfonated polystyrene exhibited proton conductivity equal to that of Nafion[®] membrane and the permeability of PSSA is comparatively smaller, which is about two times lower than that of Nafion[®] membrane.

c) Sulfonated poly(ether ether ketone)

Research on sulfonated poly(ether ether ketone) (SPEEK) has also been extensively carried out worldwide. Its interesting features such as adequate proton conductivity, low methanol permeability, good mechanical strength and high thermal stability has upgraded this polymer as one of the most potential PEM for DMFC. The sulfonation of poly(ether ether ketone) (PEEK) is similar to the sulfonation technique for PSSA using sulfonation agent. The degree of sulfonation (DS) of SPEEK can be controlled by varying reaction time and temperature [78]. The work of Li *et al.* [27] showed that the proton conductivity of SPEEK membrane depends on the DS, which the proton conductivity increased with DS. It is believed that with the increment of DS, the polymer becomes more hydrophilic and absorbs more water, and this phenomenon gives opportunity to the formation of water-mediated pathways for protons. Methanol permeation measurement indicates that its rate increases with the increment of DS but at a much lower rate than Nafion[®] membrane. The different methanol permeation of SPEEK and Nafion[®] membranes can be explained by the difference in their microstructures [27].

d) Poly(vinyl alcohol)

Libby *et al.* [20] showed that poly(vinyl alcohol) (PVA) can be easily formed into membrane and its permeability can be altered with heat. PVA is also a good methanol barrier and the methanol permeability of its membrane decreases with increasing methanol concentration (it does the reverse for Nafion[®]) [62]. Thus, at higher methanol concentrations, PVA becomes a better methanol barrier, while Nafion[®] becomes an even poorer barrier. PVA has also comparatively high conductivity at approximately 10^{-2} cm/s.

e) Sulfonated poly(arylene ether sulfone)

Sulfonated poly(arylene ether sulfone) (BPSH) is commonly prepared through the direct polymerization of sulfonated monomer because several distinctive advantages; the precise control of disulfonation, with up to two sulfonic acid groups per repeat unit, and the option of making higher molecular weight, more durable and ductile films [63]. The method of fabricating BPSH membrane is similar to other membranes, i.e. dissolving of BPSH into a solvent and casting of the solution onto a clean glass plate. Then, two methods of

acidification treatment can be applied to convert the membrane to the required acid form [63-64]; *Method 1* involves the immersion of cast membrane in 1.5 M sulfuric acid solution at 30 °C for 24 h, followed by immersion of sulfonated membrane in deionized water at 30 °C for 24 h. In contrast to *Method 1*, *Method 2* uses immersion of cast membrane in 0.5 M boiling sulfuric acid solution for 2 h, followed by treatment with boiling deionized water for 2 h. As reported elsewhere [63-64, 79], the morphology of BPSH membrane is relatively dependent on the degree of disulfonation (DDS) and acidification treatment. It was also found that the BPSH membrane showed much lower methanol permeability and higher selectivity than Nafion[®] 117.

f) *Polyphosphazene*

Two types of polyphosphazene (PPh) group such as sulfonated and phosphonated PPh have been developed recently for DMFC application [66, 80-81]. The synthesis of both sulfonated and phosphonated materials begins with poly(dichlorophosphazene), which is then modified through macromolecular substitution to produce PPh intermediate (the structure of this polymer is shown in Table 7). The polymer is consequently treated with SO₃ and dichloroethane to functionalize sulfonated PPh or treated with dialkyl phosphonate before going through hydrolysis process to produce phosphonated PPh. Zhou *et al.* [66] reported that the methanol crossover of sulfonated membrane was about 8 times lower than that of Nafion[®] 117 membrane at room temperature even though the values were comparable at 120 °C. The permeability of phosphonated PPh derivative was about 40 times lower than that of the Nafion[®] 117 membrane at room temperature and about 9 times lower at 120 °C. Although the conductivities of both PPh membranes were lower than that of Nafion[®] 117 membrane, they are still practical for DMFC applications since the selectivity of both sulfonated PPh (at temperature < 85 °C) and phosphonated PPh (at temperature 22 to 125 °C) are higher than that of Nafion[®] 117.

g) *Polybenzimidazole*

Polybenzimidazole (PBI) polymer is synthesised from aromatic bis-*o*-diamines and dicarboxylates (acids, esters, amides), either in molten state or in solution [82]. It is an amorphous thermoplastic polymer with a glass transition temperature, T_g, of 425–436 °C [83] and demonstrates an excellent thermal and chemical stability and good mechanical properties [84]. Moreover, PBI exhibits a good protonic conductivity even at low relative humidity [67]. Like the sulfonation process for SPEEK, SPI and other polymers, PBI has to be doped with several acids in order to improve its conductivity. Various doping acids such as sulfuric acid, phosphoric acid, boric acid, hydrochloric acid and nitric acid were investigated and of these sulfuric acid and phosphoric acid were found to give high conductivity [83]. The acids act both as donors and acceptors in proton transfer and therefore allow for proton migration along the anionic chain. PBI also showed a lower methanol permeability [62, 82].

h) *Sulfonated polysulfone*

Aromatic polysulfone (PSf) based membranes are attractive for fuel cell applications due to its good thermal stability and mechanical properties. However, studies on the performance of this membrane in DMFC application are very limited. Fu and Manthiram [68] synthesized sulfonated polysulfone (SPSf) by dissolving PSf in chloroform and treating with trimethylsilyl chlorosulfonate to produce a silyl sulfonate PSf intermediate (SSPI). Subsequently, sodium methoxide was added to the solution to cleave the SSPI and then to produce SPSf. To fabricate SPSf membranes, the SPSf were dissolved using *N,N*-dimethylacetamide (DMAc) solution and the polymer solution were then cast onto a glass. To obtain a membrane thickness of around 100 to 120 μm. Proton conductivity measurement showed that the conductivity of the SPSf membranes increase with increasing temperature

(from 65 to 80 °C), which is similar to that found in Nafion[®]. However, the corresponding conductivity values are lower as compared to those of Nafion[®] 115. The methanol crossover limiting current densities are only one-third of that found in Nafion[®] 115, indicating much lower methanol permeability even the thickness of SPSf membranes is similar to that of Nafion[®] 115. Although SPSf membrane has lower proton conductivity than Nafion[®], the lower production cost and methanol crossover make them promising alternatives for DMFC.

i) Sulfonated poly(phthalazinone ether ketone)

Sulfonated poly(phthalazinone ether ketone) (SPPEK) has been discovered as a new kind of PEM for DMFC due to its superior performance in terms of chemical and oxidative resistance, mechanical strength, thermal stability, glass transition temperature (about 263 °C) and proton conductivity [69, 85-86]. It also has a lower methanol permeation rate compared to Nafion[®] membrane because of a less permeable membrane material [29]. As reported elsewhere [69, 85, 87], SPPEK can be prepared by both post-sulfonation of PPEK and direct polymerization of pre-sulfonated monomers. Tian *et al.* [69] reported that SPPEK prepared from direct polymerization of pre-sulfonated monomer has better performance in terms of thermal stability, water affinity and proton conductivity than that of post-sulfonation as the post-sulfonation technique may not only deteriorate the mechanical and thermal stabilities of resulting membrane material (because of the cleavage of ether bond), but also fail to control the degree and location of sulfonation.

Table 7: Non-fluorinated polymer membranes used in DMFC

Polymer	Structure	Conduction Mechanism	Proton Conductivity (S/cm)	Methanol Permeability (cm ² /s)
Sulfonated polyimides		Involve water [18]	(0.17-4.10) $\times 10^{-2}$ [18]	(0.9-73.4) $\times 10^{-7}$ [18]
Polystyrene sulfonic acid		Does not involve water [25]	(0.15-5.0) $\times 10^{-2}$ [25]	(2.7-52.0) $\times 10^{-6}$ [25]
Sulfonated poly(ether ether ketone)		Involve water [27]	(1.30-5.05) $\times 10^{-3}$ [27]	(2.0-9.07) $\times 10^{-8}$ [27]

Table 7 (continued)

Polymer	Structure	Conduction Mechanism	Proton Conductivity (S/cm)	Methanol Permeability (cm ² /s)
Poly (vinyl alcohol)	 $\left[\text{CH}_2 - \underset{\text{OH}}{\text{CH}} \right]_n$	Involve water [61]	(1.4-5.3) × 10 ⁻² [62]	(1.4-5.5) × 10 ⁻⁷ [62]
Sulfonated poly (arylene ether sulfones)	 $\left[\text{O} - \text{C}_6\text{H}_4 - \text{C}_6\text{H}_4 - \text{O} - \text{C}_6\text{H}_4 - \text{SO}_2 - \text{C}_6\text{H}_4 \right]_{1-x} \text{CO} \left[\text{O} - \text{C}_6\text{H}_4 - \text{C}_6\text{H}_4 - \text{O} - \text{C}_6\text{H}_3(\text{SO}_3\text{H}) - \text{SO}_2 - \text{C}_6\text{H}_3(\text{SO}_3\text{H}) \right]_x$	Involve water [63]	(0.70-50) × 10 ⁻² [64]	7.7 × 10 ⁻⁶ [65]
Polyphosphazene	 $\left[\text{N} = \text{P} \left(\text{O} - \text{C}_6\text{H}_4 - \text{R} \right) \right]_n$	Involve water [66]	(3.49-5.65) × 10 ⁻² [66]	(2.77-14.1) × 10 ⁻⁸ [66]

Table 7 (continued)

Polymer	Structure	Conduction Mechanism	Proton Conductivity (S/cm)	Methanol Permeability (cm ² /s)
Poly-benzimidazole		Does not involve water [67]	5.6×10^{-3} [62]	8.3×10^{-9} [62]
Sulfonated polysulfone		Involve water [68]	No information	No information
Sulfonated poly (phthalazinone ether ketone)		Involve water [69]	1.06×10^{-2} [69]	No information

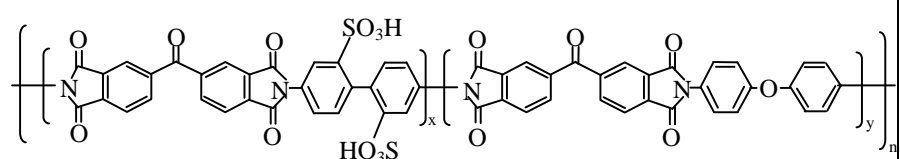
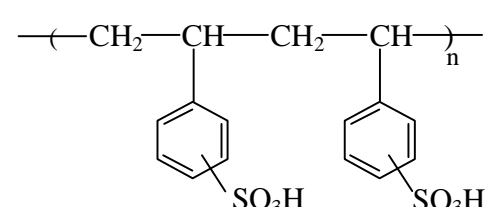
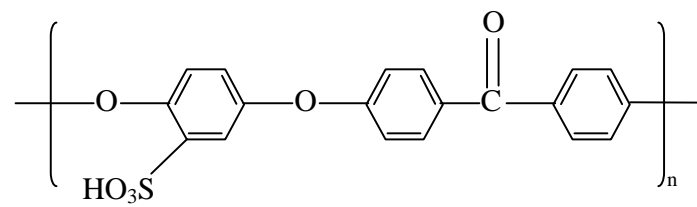
3.3.2 Composite membranes of non-fluorinated polymers

Composite membrane incorporates inorganic materials, acids or other polymers into a polymer matrix. Therefore, the term “composite membrane” can be used to describe any membrane made of:

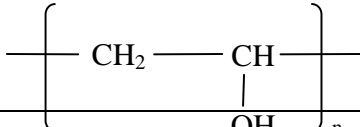
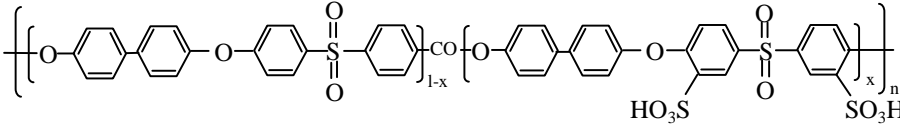
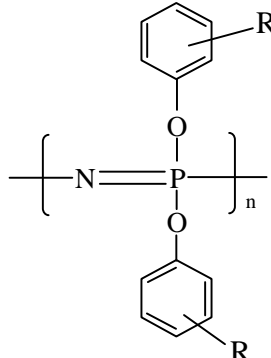
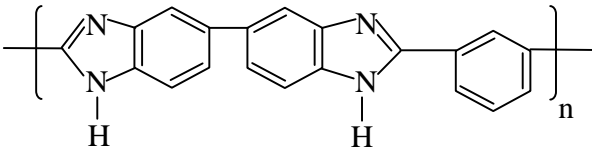
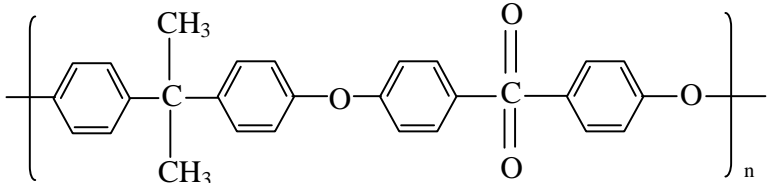
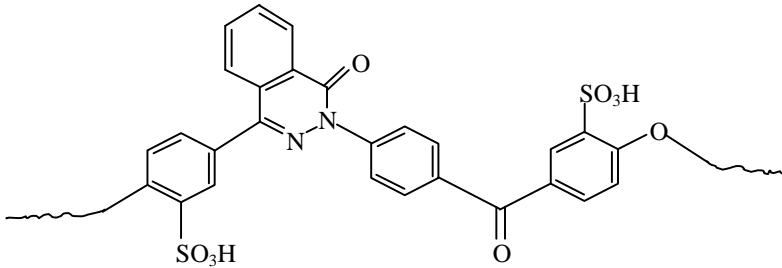
- a) polymer and inorganic materials/acids (at least one of each of the polymer and inorganic materials), or
- b) several polymer components (at least two different organic components which may have complementary properties).

Composite allows a blending/modification of the different properties of each component to improve an overall material performance. The addition of an inorganic material/acid or other polymer into a polymer membrane can alter and improve physical and chemical polymer properties of interest (such as proton conductivity, methanol permeation rate, thermal stability and mechanical strength) while retaining its important properties to enable DMFC operation. Table 8 summarizes the modifications of non-fluorinated based polymers.

From the above table, it indicates that SPEEK has been frequently used as base polymer membrane for fabricating PEM in DMFC. SPEEK has also been shown to have more advantages compared than other polymers, such as high mechanical strength, high thermal stability, cheap, easily to handle and low methanol crossover. In addition, the moderate proton conductivity of SPEEK, which is only around $1.30\text{-}5.05 \times 10^{-3}$ S/cm [27], is the main reason for researchers to adopt composite membrane of SPEEK in efforts to enhance the conductivity of SPEEK. It is also worth taking note that zirconium phosphate has the potential to be a “partner” for SPEEK as this inorganic compound has a good chemistry with SPEEK. This would enhance the conductivity of SPEEK without seriously detracting other SPEEK properties [29, 82, 96].

In term of fabrication techniques, most researchers used blending and *in-situ* methods for the incorporation of inorganic material into composite membranes as the blending technique is easy to prepare and low time consuming, and the *in-situ* technique is generally avoids any sedimentation of the inorganic material and assures the greatest possible interface due to the intimacy of contact between the inorganic material and polymer. Other techniques adopted by researchers are plasma-induced polymerization and pore-fill methods.

Table 8. Composite membranes of non-fluorinated based polymers for DMFC

Category	Polymer	Inorganic / acid / polymer	Modification technique	Research Intention	Reference
Polymer - Inorganic Material/ Acid	Sulfonated poly(ether ketone) (SPEK) and sulfonated poly(ether ether ketone) (SPEEK)	SiO ₂ , TiO ₂ or ZrO ₂ , Zirconium phosphate (ZrP)	Generated SiO ₂ , TiO ₂ or ZrO ₂ network in the SPEK and SPEEK solution by hydrolysis and condensation and added ZrP into polymers solution	To provide a general method for reducing the methanol permeability in PEM by inorganic modification. The first approach consists of <i>in situ</i> generation of SiO ₂ , TiO ₂ , ZrO ₂ and the second approach is the incorporation of ZrP	[29]
	Polyethylene glycol (PEG)	SiO ₂ , Proton carrier: 4 - dodecylbenzene sulfonic acid (DBSA)	Prepared hybrid precursor by mixed PEG & SiO ₂ precursor before added chemical stabilizer and DBSA	To synthesize a series of hybrid membranes based on PEG/SiO ₂ through sol-gel processes and using much lower cost proton carrier, DBSA, to provide conductivity to membranes	[88]
	Poly (vinyl alcohol) (PVA)	Mordenite	Mixed mordenite suspension with PVA solution	To seek a new membrane with lower methanol crossover	[20]
	Poly (vinyl alcohol) (PVA)	Phosphotungstic acid (PWA)	Mixed different % of PWA with PVA solution	To prepare a membrane based on PVA with embedded PWA and study their proton conductivity and methanol permeability	[90]
	Sulfonated poly(ether ketone) (SPEK)	Zirconium oxide (ZrO ₂) and Zirconium phosphate (ZrP)	Formed ZrO ₂ by <i>in situ</i> hydrolysis and condensation in the SPEK solution and then added ZrP as dispersion to the polymer solution	To present a critical comparison of different characterisation methods to determine the swelling, the water/methanol crossover, the proton conductivity and the performance in a DMFC test stand	[91]
	Sulfonated poly(ether ketone) (SPEK)	Heteropolyacids (HPA), ZrO ₂ , RSiO _{3/2}	Formed ZrO ₂ & RSiO _{3/2} by <i>in situ</i> hydrolysis and condensation in the SPEK solution and added HPA to the solution	To investigate fundamental points such as methanol and water permeabilities of membrane containing HPA, in combination with its ability of transporting protons	[89]

Table 8 (continued)

Category	Polymer	Inorganic / acid / polymer	Modification technique	Research Objective	Reference
Polymer - Inorganic Material/ Acid	Sulfonated poly(ether ether ketone) (SPEEK)	Divacant tungstosilicate (DTS) and silica	Added silica precursor and DTS into SPEEK solution	To prepare SPEEK membrane containing heteropolyacid and an oxide phase	[92]
	Poly (vinyl alcohol) (PVA)	Phosphotungstic acid (PWA) and silica	Added silica precursor into PVA / PWA solution	To fabricate a series of new proton conductivity composite PVA membranes for DMFC application	[61]
	Sulfonated poly(ether ether ketone) (SPEEK)	Synthetic non-spherical silicates (Laponite and MCM-41)	Added the SPEEK polymer to the silicate dispersion solution	To prepare SPEEK/silicates nanocomposite membrane and compare the results with spherical silica and <i>in situ</i> generated silica, in order to understand the influence of silicates shape on membrane performances	[93]
	Poly (vinyl alcohol) (PVA)	Phosphotungstic acid (PWA)	Added desired concentration of PWA solution into PVA solution	To prepare PWA/PVA hybrid membrane via slightly modified solution-blending method and to study the influence of the dispersed PWA on the membrane	[94]
	Sulfonated poly(ether ether ketone) (SPEEK)	Zirconia (ZrO ₂)	Prepared composite membrane using <i>in situ</i> formation of ZrO ₂ with zirconium tetrapropylate as alkoxide and acetyl acetone as chelating agent.	To characterize a series of organic-inorganic composite membrane with an extended range of zirconium oxide contents (2.5-12.5 wt.%), from standard characterization methods to field tests under DMFC conditions	[95]
	Sulfonated poly(ether ether ketone) (SPEEK)	Zirconium phosphate (ZrP) and poly-benzimidazole (PBI)	Added ZrP/PBI dispersion solution into SPEEK solution	To characterize the composite membrane via impedance spectroscopy and DMFC tests at medium temperature (110 °C)	[96]

Table 8 (continued)

Category	Polymer	Inorganic / acid / polymer	Modification technique	Research Objective	Reference
Polymer - Inorganic Material/ Acid	Sulfonated poly(ether ether ketone) (SPEEK)	Zirconium phosphate (ZrP) and poly-benzimidazole (PBI)	Added ZrP/PBI dispersion solution into SPEEK solution	To evaluate DMFC performances at low/medium temperatures using SPEEK/ZrP/PBI composite membrane	[97]
	Sulfonated poly(phthalazinone ether ketone) (SPPEK)	Silica	Added silica nanoparticle into SPPEK solution	To prepare organic-inorganic nanocomposite membrane and to examine the properties of membrane and the single cell performance	[87]
	Cross-linked polyethylene (CLPE)	Acrylamide <i>tert</i> -butyl sulfonate (ATBS)	Filled ATBS into CLPE membrane pore	To study the effect of methanol concentration on the membrane performance	[98]
	Sulfonated poly(ether ether ketone) (SPEEK)	Zirconium phosphate (ZrP)	Incorporated ZrP precipitated <i>in situ</i> in SPEEK membrane	To evaluate non-commercial MEA comprising fabricated composite membrane in a high temperature DMFC stack	[82]
	Sulfonated poly(ether ether ketone) (SPEEK)	Organic-montmorillonite (OMMT)	Added appropriate weights of OMMT to SPEEK solution	To prepare SPEEK/OMMT nanocomposite membrane using intercalation technique and compare the microstructures of SPEEK/MMT and SPEEK/OMMT	[99]
	Sulfonated poly(ether ether ketone) (SPEEK)	Boron orthophosphate (BPO ₄)	Added BPO ₄ into SPEEK solution	To develop and characterize composite SPEEK/BPO ₄ membrane for DMFC application	[100]
Polymer - Polymer	Polyvinyl alcohol (PVA)	Polystyrene sulfonic acid (PSSA)	Dissolved both PVA and PSSA in solvent	To seek methanol barrier membrane that has proper hydrophobic-hydrophilic balance by blending two polymers, each with relatively hydrophobic backbones and hydrophilic side chains, under different ratios	[101]

Table 8 (continued)

Category	Polymer	Inorganic / acid / polymer	Modification technique	Research Objective	Reference
Polymer - Polymer	Polyethersulfone (PES)	Sulfonated poly-sulfone (PSf) and sulfonated poly(ether ether ketone) (SPEEK)	Dissolved appropriate ratio of PES/SPSf and PES/SPEEK in solvent	To fabricate blend membranes of PES/SPSf and PES/SPEEK, and to define the properties of blend membranes which may be applied to DMFC system	[28]
	Polybenzimidazole (PBI)	Sulfonated polysulfone (SPf)	Dissolved appropriate ratio of PBI and SPf in solvent	To compare PBI/SPf composite membrane with SPf homopolymer membrane, blend of polyethersulfone/SPf and Nafion® 117	[102]
	Polypropylene (PP)	Polystyrene sulfonic acid (PSSA)	Grafted PSSA on the surface of microporous PP membranes via a plasma-induced polymerization method	To prepare PSSA-g-PP composite membrane and characterize its physical and electro-chemical properties for the application of PEM in the DMFC.	[9]
	Polystyrene sulfonic acid (PSSA)	Sulfonated poly(2,6-dimethyl-1,4-phenylene oxide) (SPPO)	Prepared PSSA/SPPO blend solution by dissolved the both polymer in toluene/methanol mixture solvent	To perform the structural analysis of blend membrane, the transport properties through the blend membrane, and a feasibility test of the blend membrane for DMFC	[103]
	Poly(vinyl alcohol) (PVA) and Poly(vinyl pyrrolidone) (PVP)	2-acrylamido-2-methyl-1-propane-sulfonic acid (PAMPS)	Prepared water solutions of PVA and PVP separately, then mixed appropriate amounts of the two solutions with PAMPS	To prepare new proton-conducting ternary blend polymer membrane with PVA-PAMPS-PVP in combination with chemical crosslinking.	[104]
	Polysulfone (PSf)	Poly(ethylene glycol) (PEG)	Deposited PEG solution onto the top surface of support PSf membrane	To prepare the membrane and determine the experimental diffusivity, proton conductivity, methanol permeability and other properties	[105]

4. Future Directions

The fabrication of composite polymer/inorganic material membrane is considered to be the most promising development in polymer electrolyte membrane (PEM) for direct methanol fuel cell (DMFC) application as the inorganic material could enhance the properties of polymer membrane. Its becomes even more attractive when the composite has the potential to balance between two important characteristics in DMFC, i.e. proton conductivity and methanol permeability. Therefore, special attention has to be given to composite techniques in developing electrolyte membrane since these techniques have proven their effectiveness. For instant, the function of acidity of inorganic fillers such as silica and alumina is able to facilitate the proton transfer mechanism of the membrane, the proton conduction from the surface of the zirconium phosphate itself, is also improving the overall proton conductivity of the membrane, and the ability of Pd film to reduce the methanol crossover of membrane.

Glossary/Nomenclature

σ	-	Proton conductivity
α	-	Selectivity
C	-	Coulomb
EW	-	Equivalent weight
i	-	Current density
I-V	-	Current-voltage
l	-	Membrane thickness
R	-	Resistance
S	-	Membrane area
S	-	Siemen

References

- [1] Taft, K.M., Kurano, M.R.: Composite electrolyte for fuel cells. 6,630,265, United States (2003).
- [2] Savadogo, O., Emerging membranes for electrochemical systems: Part II. High temperature composite membranes for polymer electrolyte fuel cell (PEFC) applications, *Journal of Power Sources*, 127: 135-161 (2004).
- [3] Smitha, B., Sridhar, S., Khan, A.A., Solid polymer electrolyte membranes for fuel cell applications - a review, *Journal of Membrane Science*, 259: 10-26 (2005).
- [4] Zaidi, S.M.J., Development of proton conducting composite membranes for fuel cell applications, PhD Thesis, Laval University (2000).
- [5] Souzy, R., Ameduri, B., Functional fluoropolymers for fuel cell membranes, *Progress Polymer Science*, 30: 644-687 (2005).
- [6] Larminie, J., Dicks, A., *Fuel Cell Systems Explained*, John Wiley & Sons, West Sussex, England (2000).

- [7] Li, Q., He, R., Jensen, J.O., Bjerrum, N.J., Water uptake and acid doping of polybenzimidazoles as electrolyte membranes for fuel cells, *Solid State Ionics*, 15: 4896-4915 (2003).
- [8] Kawamura, J., Hattori, K., Hongo, T., Asayama, R., Kuwata, N., Hattori, T., Mizusaki, J., Microscopic states of water and methanol in Nafion membrane observed by NMR micro imaging, *Solid State Ionics*, 176: 2451-2456 (2005).
- [9] Bae, B., Kim, D., Sulfonated Polystyrene Grafted polypropylene composite electrolyte membranes for direct methanol fuel cells, *Journal of Membrane Science*, 220: 75–87 (2003).
- [10] Gibbs, H.H., Vienna, V.W., Griffin, R.N.: Fluorocarbon sulfonyl fluorides. 3,041,317, United States (1962).
- [11] Connolly, D.J., Longwood, Gresham, W.F.: Fluorocarbon vinyl ether polymers. 3,282,875, United States (1966).
- [12] Basura, V.I., Chuy, C., Beattie, P.D., Holdcroft, S., Effect of equivalent weight on electrochemical mass transport properties of oxygen in proton exchange membranes based on sulfonated α,β,β -trifluorostyrene (BAM[®]) and sulfonated styrene-(ethylene-butylene)-styrene triblock (DAIS-analytical) copolymers, *Journal of Electroanalytical Chemistry*, 501: 77-88 (2001).
- [13] Jung, D.H., Lee, C.H., Kim, C.S., Shin, D.R., Performance of a direct methanol polymer electrolyte fuel cell, *Journal of Power Sources*, 71: 169-173 (1998).
- [14] Liu, J.G., Zhao, T.S., Liang, Z.X., Chen, R., Effect of membrane thickness on the performance and efficiency of passive direct methanol fuel cells, *Journal of Power Sources*, 153: 61-67 (2005).
- [15] Tsampas, M.N., Pikos, A., Brosda, S., Katsaounis, A., Vayenas, C.G., The effect of membrane thickness on the conductivity of Nafion, *Electrochimica Acta*, 51: 2743-2755 (2005).
- [16] Hsu, W.Y., Gierke, T.D., Ion transport and slustering in Nafion perfluorinated membrane, *Journal of Membrane Science*, 13: 307-326 (1983).
- [17] Yeager, H.L. and Steck, A., Cation and water diffusion in Nafion ion exchange membranes: Influence of polymer structure, *Journal Electrochemical Society*, 128: 1880-1884 (1981).
- [18] Woo, Y., Oh, S.Y., Kang, Y.S., Jung, B., Synthesis and characterization of sulfonated polyimide membranes for direct methanol fuel cell, *Journal of Membrane Science*, 220: 31-45 (2003).
- [19] Tricoli, V., Proton and methanol transport in poly(perfluorosulfonate) membranes containing Cs⁺ and H⁺ cations, *Journal Electrochemical Society*, 45: 3798-3810 (1998).

- [20] Libby, B., Smyrl, W.H., Cussler, E.L., Polymer-zeolite composite membrane for direct methanol fuel cells, *AIChE Journal*, 49: 991-1001 (2003).
- [21] Murphy, J.O., Cisar, A.L.: Composite membrane suitable for use in electrochemical devices. 6,387,230, United States (2002).
- [22] Smit, E.A., Ocampo, A.L., Espinosa-Medina, M.A, Sebastian, P.J., A modified Nafion membrane with in situ polymerized polypyrrole for the direct methanol fuel cell, *Journal of Power Sources*, 124: 59-64 (2003).
- [23] Jung, D.H., Cho, S.Y., Peck, D.H., Shin, D.R., Kim, J.S., Performance evaluation of a Nafion/silicon oxide hybrid membrane for direct methanol fuel cell. *Journal of Power Sources*, 106: 173-177 (2002).
- [24] Siroma, Z., Fujiwara, N., Ioroi, T., Yamazaki, S., Yasuda, K. and Miyazaki, Y., Dissolution of Nafion[®] membrane and recast Nafion[®] film in mixtures of methanol and water, *Journal of Power Sources*, 126: 41-45 (2003).
- [25] Carretta, N., Tricoli, V, Picchioni, F., Ionomeric membranes based on partially sulfonated poly(styrene): Synthesis, proton conduction and methanol permeation, *Journal of Membrane Science*, 166: 189-197 (2000).
- [26] Choi, W.C., Kim, J.D., Woo, S.I., Modification of proton conducting membrane for reducing methanol crossover in a direct-methanol fuel cell, *Journal of Power Sources*, 96: 411-414 (2001).
- [27] Li, L., Zhang, J., Wang, Y., Sulfonated poly (ether ether ketone) membranes for direct methanol fuel cell, *Journal of Membrane Science*, 226: 159-167 (2003).
- [28] Manea, C., Mulder, M., New polymeric electrolyte membranes based on proton donor-proton acceptor properties for direct methanol fuel cells, *Journal of Membrane Science*, 206: 443-453 (2002).
- [29] Nunes, S.P., Ruffmann, B., Rikowski, E., Vetter, S., Richau, K., Inorganic modification of proton conductive polymer membranes for direct methanol fuel cells, *Journal of Membrane Science*, 203: 215-225 (2002).
- [30] Sun, Y.M., Wu, T.C., Lee, H.C., Jung, G.B., Guiver, M.D., Gao, Y., Liu, Y.L., Lai, J.Y., Sulfonated poly(phthalazinone ether ketone) for proton exchange membranes in direct methanol fuel cells, *Journal of Membrane Science*, 265: 108-114 (2005).
- [31] Feichtinger, J., Galm, R., Walker, M., Baumgartner, K.M., Schulz, A., Rauchle, E., Schumacher, U., Plasma polymerized barrier films on membranes for direct methanol fuel cells, *Surface and Coatings Technology*, 142-144: 181-186 (2001).
- [32] Yoon, S.R., Hwang, G.H., Cho, W.I., Oh, I.H., Hong, S.A., Ha, H.Y., Modification of polymer electrolyte membranes for DMFCs using Pd films formed by sputtering, *Journal of Power Sources*, 106: 215-223 (2002).
- [33] Ma, Z.Q., Cheng, P., Zhao, T.S., A palladium-alloy deposited Nafion membrane for direct methanol fuel cells, *Journal of Membrane Science*, 215: 327-336 (2003).

- [34] Jung, D.H., Cho, S.Y., Peck, D.H., Shin, D.R., Kim, J.S., Preparation and performance of a Nafion[®]/montmorillonite nanocomposite membrane for direct methanol fuel cell, *Journal of Power Sources*, 118: 205-211 (2003).
- [35] Shao, Z.G., Wang, X., Hsing, I.M., Composite Nafion/polyvinyl alcohol membranes for the direct methanol fuel cell, *Journal of Membrane Science*, 210: 147-153 (2002).
- [36] Arico, A.S., Baglio, V., Blasi, A.D., Creti, P., Antonucci, P.L., Antonucci, V., Influence of the acid-base characteristics of inorganic fillers on the high temperature performance of composite membranes in direct methanol fuel cells, *Solid State Ionics*, 161: 251– 265 (2003).
- [37] Arico, A.S., Baglio, V., Blasi, A.D., Modica, E., Antonucci, P.L. and Antonucci, V., Surface properties of inorganic fillers for application in composite membranes-direct methanol fuel cells, *Journal of Power Sources*, 128: 113-118 (2003).
- [38] Staiti, P., Arico, A.S., Baglio, V., Lufrano, F., Passalacqua, E., Antonucci V., Hybrid Nafion-silica membranes doped with heteropolyacids for application in direct methanol fuel cells, *Solid State Ionics*, 145: 101–107 (2001).
- [39] Antonucci, P.L., Arico, A.S., Creti, P., Ramunni, E., Antonucci, V., Investigation of a direct methanol fuel cell based on a composite Nafion-silica electrolyte for high temperature operation, *Solid State Ionics*, 125: 431-437 (1999).
- [40] Bauer, F. and Porada, M.W., Microstructural characterization of Zr-phosphate-Nafion[®] membranes for direct methanol fuel cell (DMFC) applications, *Journal of Membrane Science*, 233: 141-149 (2004).
- [41] Souzy, R., Ameduri, B., Boutevin, B., Functional fluoropolymers for fuel cell membranes, *Progress in Polymer Science*, 29: 75-106 (2004).
- [42] Cohen, S.G., Wolosinski, H.T., Scheuer, P.J., α,β,β -trifluorostyrene and α -chloro- β,β -difluorostyrene, *Journal Am Chemistry Society*, 71: 3439-3440 (1949).
- [43] Prober, M., The synthesis and polymerization of some fluorinated styrenes, *Journal Am Chemistry Society*, 75: 968-973 (1953).
- [44] Dixon, S., Elimination reaction of fluoro-olefins with organolithium compounds, *Journal Organic Chemistry*, 21: 400-403 (1956).
- [45] Kazennikova, G.V., Talamaeva, T.V., Zimin, A.V., Simonov, A.P., Kocheshkov, K.A., Fluorinated Styrenes. V. α,β,β -Trifluorostyrenes, *Izv Akad Nauk, SSSR, Otd Khim Nauk*, 1063-1065 (1961).
- [46] Rybakova, L.F., Panov, E.M., Nikitina, A.A., Kocheshkov, K.A., Karandi, I.V., Synthesis and properties of trimethylsilyl esters of fluoro-containing vinylbenzenesulfonic acids, *Zh Obshch Khim*, 46: 117-121 (1976).

- [47] Sorokina, R.S., Rybakova, L.F., Kalinovskii, I.O., Chernoplekova, V.A., Beletskaya, I.P., Synthesis of trifluorostyrene and its derivatives by the reaction of (trifluorovinyl)trimethyltin aryl iodides in the presence of palladium complexes, *Zh Org Khim*, 18: 2458-2459 (1982).
- [48] Heinze, P.L. and Burton, D.J., Palladium-catalyzed coupling of (trifluorovinyl)zinc reagents with aryl iodides. An improved synthesis of α,β,β -trifluorostyrenes and the stereospecific preparation of fluorinated 1-phenylpropenes, *Journal Fluorine Chemistry*, 31: 115-119 (1986).
- [49] Heinze, P.L. and Burton, D.J., Palladium-catalyzed coupling of (trifluorovinyl)zinc reagents with aryl iodides. A new, simple synthesis of α,β,β -trifluorostyrenes and the stereoselective preparation of 1-arylperfluoropropenes, *Journal Organic Chemistry*, 53: 2714-2720 (1988).
- [50] Tevlina, A.S., Ivankin, A.N., Korshak, V.V., Baranova, N.P., Nikitina, T.S., Rokhlin, E.M., Copolymerization of α,β,β -trifluorostyrene with some vinyl monomers, *Viniti Chem. Abst.*, 127-81: 12 (1981).
- [51] Stone, C, Steck, A.E., Lousenberg, R.D.: Substituted trifluorostyrene compositions. 5,602,185, United States (1997).
- [52] Wei, J., Stone, C., Steck, A.E.: Trifluorostyrene and substituted trifluorostyrene copolymeric compositions and ion-exchange membranes formed therefrom. 5,422,411, United States (1995).
- [53] Beattie, P.D., Orfino, F.P., Basura, V.I., Zychowska, K., Ding, J., Chuy, C., Schmeisser, J., Holdcroft, S., Ionic conductivity of proton exchange membranes, *Journal of Electroanalytical Chemistry*, 503: 45–56 (2001).
- [54] Połtarzewski, Z., Wieczorek, W., Przyłuski, J., Antonucci, V., Novel proton conducting composite electrolytes for application in methanol fuel cells, *Solid State Ionics*, 119: 301-304 (1999).
- [55] Yamaguchi, T., Miyata, F., Nakao, S., DMFC performances using a pore-filling polymer electrolyte membrane for portable usages, *Journal of Membrane Science*, 214: 283-292 (2003).
- [56] Chen, J., Asano, M., Yamaki, T., Yoshida, M., Preparation of sulfonated crosslinked PTFE-*graft*-poly(alkyl vinyl ether) membranes for polymer electrolyte membrane fuel cells by radiation processing, *Journal of Membrane Science*, 256: 38-45 (2005).
- [57] Chen, J., Asano, M., Yamaki, T., Yoshida, M., Preparation and characterization of chemically stable polymer electrolyte membranes by radiation-induced graft copolymerization of four monomers into ETFE films, *Journal of Membrane Science*, 269: 194-204 (2005).
- [58] Shen, M., Roy, S., Kuhlmann, J.W., Scott, K., Lovell, K., Horsfall, J.A., Grafted polymer electrolyte membrane for direct methanol fuel cells, *Journal of Membrane Science*, 251: 121-130 (2005).

- [59] Nasef, M.M., Zubir, N.A., Ismail, A.F., Dahlan, K.Z.M., Saidi, H. and Khayet, M., Preparation of radiochemically pore-filled polymer electrolyte membranes for direct methanol fuel cells, *Journal of Power Sources*, 156: 200-210 (2005).
- [60] Nasef, M.M., Zubir, N.A., Ismail, A.F., Khayet, M., Dahlan, K.Z.M., Saidi, H., Rohani, R., Ngah, T.I.S., Sulaiman, N.A., PSSA pore-filled PVDF membranes by simultaneous electron beam irradiation: Preparation and transport characteristics of protons and methanol, *Journal of Membrane Science*, 268: 96-108 (2005).
- [61] Xu, W., Liu, C., Xue, X., Su, Y., Lv, Y., Xing, W., Lu, T., New proton exchange membranes based on poly (vinyl alcohol) for DMFCs, *Solid State Ionics*, 171: 121-127 (2004).
- [62] Pivovar, B.S, Wang, Y., Cussler, E.L., Pervaporation membranes in direct methanol fuel cells, *Journal of Membrane Science*, 154: 155-162 (1999).
- [63] Kim, Y.S., Hickner, M.A., Dong, L., Pivovar, B.S., McGrath, J.E., Sulfonated poly(arylene ether sulfone) copolymer proton exchange membranes: Composition and morphology effects on the methanol permeability, *Journal of Membrane Science*, 243: 317-326 (2004).
- [64] Kim, Y.S., Dong, L., Hickner, M.A., Pivovar, B.S., McGrath, J.E., Processing induced morphological development in hydrated sulfonated poly(arylene ether sulfone) copolymer membranes polymer, 44: 5729-5736 (2003).
- [65] Every, H.A., Hickner, M.A., McGrath, J.E., Zawodzinski, J.T.A., An NMR study of methanol diffusion in polymer electrolyte fuel cell membranes, *Journal of Membrane Science*, 250: 183-188 (2005).
- [66] Zhou, X., Weston, J., Chalkova, E., Hofmann, M.A., Ambler, C.M., Allcock, H.R., Lvov, S.N., High temperature transport properties of polyphosphazene membranes for direct methanol fuel cells, *Electrochimica Acta*, 48: 2173-2180 (2003).
- [67] Bouchet, R., Siebert, E., Proton conduction in acid doped polybenzimidazole, *Solid State Ionics*, 118: 287-299 (1999).
- [68] Fu, Y.Z., Manthiram, A., Synthesis and characterization of sulfonated polysulfone membranes for direct methanol fuel cells, *Journal of Power Sources*, 157: 222-225 (2005).
- [69] Tian, S.H., Shua, D., Chen, Y.L., Xiao, M., Meng, Y.Z., Preparation and properties of novel sulfonated poly(phthalazinone ether ketone) based PEM for PEM fuel cell application, *Journal of Power Sources*, 158: 88-93 (2005).
- [70] Genies, C., Mercier, R., Sillion, B., Cornet, N., Gebel, G., Pineri, M., Soluble sulfonated naphthalenic polyimides as materials for proton exchange membranes, *Polymer*, 42: 359-373 (2001).

- [71] Vallejo, E., Porucelly, G., Gavach, C., Mercier, R., Pineri, M., Sulfonated polyimides as proton conductor exchange membranes. Physicochemical properties and separation H^+/M^{z+} by electro dialysis comparison with a perfluorosulfonic membrane, *Journal of Membrane Science*, 160: 127-137 (1999).
- [72] Fang, J., Guo, X., Harada, S., Watari, T., Tanaka, K., Kita, H. and Okamoto, K., Novel sulfonated polyimides as polyelectrolytes for fuel cell application. 1. Synthesis, proton conductivity, and water stability of polyimides from 4,4'-diaminodiphenyl ether-2,2'-disulfonic acid, *Macromolecules*, 35: 9022-9028 (2002).
- [73] Guo, X., Fang, J., Watari, T., Tanaka, K., Kita, H., Okamoto, K., Novel Sulfonated polyimides as polyelectrolytes for fuel cell application. 2. Synthesis and proton conductivity of polyimides from 9,9-bis(4-aminophenyl)fluorene-2,7-disulfonic acid, *Macromolecules*, 35: 6707-6713 (2002).
- [74] Yamada, O., Yin, Y., Tanaka, K., Kita, H., Okamoto, K., Polymer electrolyte fuel cells based on main-chain-type sulfonated polyimides, *Electrochimica Acta*, 50: 2655-2659 (2005).
- [75] Okamoto, K., Yin, Y., Yamada, O., Islam, M.N., Honda, T., Mishima, T., Suto, Y., Tanaka, K., Kita, H., Methanol permeability and proton conductivity of sulfonated copolyimide membranes, *Journal of Membrane Science*, 258: 115-122 (2005).
- [76] Yin, Y., Fang, J., Cui, Y., Tanaka, K., Kita, H., Okamoto, K., Synthesis, proton conductivity and methanol permeability of a novel sulfonated polyimide from 3-(20,40-diaminophenoxy)propane sulfonic acid, *Polymer*, 44: 4509-4518 (2003).
- [77] Ismail, A.F., Zubir, N., Nasef, M.M., Dahlan, K.M., Hassan, A.R., Physico-chemical study of sulfonated polystyrene pore-filled electrolyte membranes by electrons induced grafting, *Journal of Membrane Science*, 254: 189-196 (2005).
- [78] Xing, P., Robertson, G.P., Guiver, M.D., Mikhailenko, S.D., Wang, K., Kaliaguine, S., Synthesis and characterization of sulfonated poly(ether ether ketone) for proton exchange membranes, *Journal of Membrane Science*, 229: 95-106 (2004).
- [79] Wang, F., Hickner, M., Kim, Y.S., Zawodzinski, T.A., McGrath, J.E., Direct polymerization of sulfonated poly(arylene ether sulfone) random (statistical) copolymers: Candidates for new proton exchange membranes, *Journal Membrane Science*, 197: 231-242 (2002).
- [80] Guo, Q., Pintauro, P.N., Tang, H., O'Connor, S., Sulfonated and crosslinked polyphosphazene-based proton-exchange membranes, *Journal Membrane Science*, 154: 175-181 (1999).
- [81] Allcock, H.R., Hofmann, M.A., Ambler, C.M., Chalkova, E., Lvov, S.N., Zhou, X.Y., Weston, J.A., Phenyl phosphonic acid functionalized poly[aryloxyphosphazenes] as proton-conducting membranes for direct methanol fuel cells, *Journal Membrane Science*, 201: 47-54 (2002).

- [82] Jones, D.J., Rozière, J., Marrony, M., High temperature DMFC stack operating with non-fluorinated membranes, *Fuel Cells Bulletin* (October 2005).
- [83] Li, Q., He, R., Berg, R.W., Hjuler, H.A., Bjerrum, N.J., Water uptake and acid doping of polybenzimidazoles as electrolyte membranes for fuel cells, *Solid State Ionics*, 168: 177-185 (2004).
- [84] Samms, S.R., Wasmus, S., Savinell, R.F., Thermal stability of proton conducting acid doped polybenzimidazole in simulated fuel cell environments, *Journal Electrochemical Society*, 143: 1225-1232 (1996).
- [85] Gao, Y., Robertson, G.P., Guiver, M.D., Jian, X., Mikhailenko, S.D., Wang, K., Kaliaguine, S., Sulfonation of poly(phthalazinones) with fuming sulfuric acid mixtures for proton exchange membrane materials, *Journal of Membrane Science*, 227: 39-50 (2003).
- [86] Gao, Y., Robertson, G.P., Guiver, M.D., Jian, X., Mikhailenko, S.D., Kaliaguine, S., Proton exchange membranes based on sulfonated poly(phthalazinone ether ketone)s/aminated polymer blends, *Solid State Ionics*, 176: 409-415 (2005).
- [87] Su, Y.H., Liu, Y.L., Sun, Y.M., Lai, J.Y., Guiver, M.D., Gao, Y., Using silica nanoparticles for modifying sulfonated poly(phthalazinone ether ketone) membrane for direct methanol fuel cell: A Significant improvement on cell performance, *Journal of Power Sources*, 155: 111-117 (2005).
- [88] Chang, H.Y., Lin, C.W., Proton conducting membranes based on PEG/SiO₂ nanocomposites for direct methanol fuel cells, *Journal of Membrane Science*, 218: 295-306 (2003).
- [89] Ponce, M.L., Prado, L., Ruffmann, B., Richau, K., Mohr, R., Nunes, S.P., Reduction of methanol permeability in polyetherketone-heteropolyacid membranes, *Journal of Membrane Science*, 217: 5-15 (2003).
- [90] Li, L., Xu, L., Wang, Y., Novel proton conducting composite membranes for direct methanol fuel cell, *Materials Letters*, 57: 1406-1410 (2003).
- [91] Ruffmann, B., Silva, H., Schulte, B., Nunes, S.P., Organic/inorganic composite membranes for application in DMFC, *Solid State Ionics*, 162-163: 269-275 (2003).
- [92] Ponce, M.L., Prado, L.A.S.D.A., Silva, V., Nunes, S.P., Membranes for direct methanol fuel cell based on modified heteropolyacids, *Desalination*, 162: 383-391 (2004).
- [93] Karthikeyan, C.S., Nunes, S.P., Prado, L.A.S.A., Ponce, M.L., Silva, H., Ruffmann, B., Schulte, K., Polymer nanocomposite membranes for DMFC application, *Journal of Membrane Science*, 254: 139-146 (2005).
- [94] Lin, C.W., Thangamuthu, R., Yang, C.J., Proton-conducting membranes with high selectivity from phosphotungstic acid-doped poly(vinyl alcohol) for DMFC applications, *Journal of Membrane Science*, 253: 23-31 (2005).

- [95] Silva, V.S., Ruffmann, B., Silva, H., Gallego, Y.A., Mendes, A., Madeira, L.M., Nunes, S.P., Proton electrolyte membrane properties and direct methanol fuel cell performance: I. Characterization of hybrid sulfonated poly(ether ether ketone)/zirconium oxide membranes, *Journal of Power Sources*, 140: 34-40 (2005).
- [96] Silva, V.S., Ruffmann, B., Vetter, S., Mendes, A., Madeira, L.M., Nunes, S.P., Characterization and application of composite membranes in DMFC, *Catalysis Today*, 104: 205-212 (2005).
- [97] Silva, V.S., Weisshaar, S., Reissner, R., Ruffmann, B., Vetter, S., Mendes, A., Madeira, L.M., Nunes, S.P., Performance and efficiency of a DMFC using non-fluorinated composite membranes operating at low/medium temperatures, *Journal of Power Sources*, 145: 485-494 (2005).
- [98] Yamaguchi, T., Kuroki, H., Miyata, F., DMFC performances using a pore-filling polymer electrolyte membrane for portable usages, *Electrochemistry Communications*, 7: 730-734 (2005).
- [99] Gaowen, Z., Zhentao, Z., Organic/inorganic composite membranes for application in DMFC, *Journal of Membrane Science*, 261 (2005) 107-113.
- [100] Othman, M.H.D., MSc. Thesis, Universiti Teknologi Malaysia, Johor Bahru, Malaysia (2006).
- [101] Wu, H., Wang, Y., Wang, S., A methanol barrier polymer electrolyte membrane in direct methanol fuel cells, *Journal of New Materials for Electrochemical Systems*, 5: 251-254 (2002).
- [102] Manea, C., Mulder, M., New polymeric electrolyte membranes based on proton donor-proton acceptor properties for direct methanol fuel cells, *Desalination*, 147: 179-182 (2002).
- [103] Jung, B., Kim, B., Yang, J.M., Transport of methanol and protons through partially sulfonated polymer blend membranes for direct methanol fuel cell, *Journal of Membrane Science*, 245: 61-69 (2004).
- [104] Qiao, J., Hamaya, T., Okada, T., New highly proton-conducting membrane poly(vinyl pyrrolidone)(PVP) modified poly(vinyl alcohol)/2-acrylamido-2-methyl-1-propanesulfonic acid (PVA-PAMPS) for low temperature direct methanol fuel cells (DMFCs), *Polymer*, 46: 10809-10816 (2005).
- [105] Zhang, X., Filho, L.P., Torras, C., Valls, R.G., Experimental and computational study of proton and methanol permeabilities through composite membranes, *Journal of Power Sources*, 145: 223-230 (2005).