

ADAPTIVE BEAM STEERING OF RLSA ANTENNA WITH RFID TECHNOLOGY

M. F. Jamlos, T. A. Rahman, and M. R. Kamarudin

Wireless Communication Centre (WCC)
Faculty of Electrical Engineering
Universiti Teknologi Malaysia
81310 UTM Skudai, Johor, Malaysia

P. Saad

Faculty of Computer Science and Information System (FSKSM)
Universiti Teknologi Malaysia
81310 UTM Skudai, Johor, Malaysia

O. A. Aziz

Wireless Communication Centre (WCC)
Faculty of Electrical Engineering
Universiti Teknologi Malaysia
81310 UTM Skudai, Johor, Malaysia

M. A. Shamsudin

Mechatronics and Robotics (MER)
Faculty of Electrical Engineering
Universiti Teknologi Malaysia
81310 UTM Skudai, Johor, Malaysia

Abstract—A form of a novel adaptive antenna system that combines radio frequency identification (RFID) technology, programmable intelligent computer (PIC) microcontroller and reconfigurable beam steering antenna is proposed. Localization and adaptive response are the most challenging issues in smart antenna system. In this research, the localization technique relying on the received signal strength (RSS) signals has been done intensively where the capability of the RFID tag in producing certain level of signal strength has been exploited as a

stimulator for the system to adaptively activate certain PIN diode switches of reconfigurable beam steering antenna. It is found that the detecting ability of the RSSI signals is extremely influenced by the 45° angle of the RFID reader's directive antenna. The combination of four 90° triangles which have 'adjacent' and 'opposite' angle of 45° forming pyramid antenna which has four sections; 1, 2, 3 and 4 enable the RFID readers to receive the RSS signals from the angles of $0^\circ/360^\circ$, 90° , 180° and 270° respectively. When the RFID tag is directly facing a certain section, certain RSS signals will 'flow' from a particular section into their respected RFID readers to automatically detect the range and angles' location of the RFID tag through the input ports of PIC microcontroller: A1, A4, C4 and C7. The PIN diode switches of the reconfigurable beam steering antenna are then activated by the output ports of PIC microcontroller: B0 up to B4, to steer the beam adaptively towards the RFID tag at four different angles: $0^\circ/360^\circ$, 90° , 180° , and 270° according to the algorithm programmed in the microcontroller. It is found that the Ground Reflection (Two-Ray) propagation model is very crucial in determining the projection and height of reconfigurable antenna to efficiently cover the scattered measurement points of 1 up to 10 at four angles with different ranges of distance. The proposed antenna has a great potential in realizing the new smart antenna system replacing the conventional adaptive array antenna and Wimax application.

1. INTRODUCTION

A conventional smart antenna system can be defined as a system which uses an array of antenna elements with a signal processing capability to automatically respond to changes of the local environment. This can be visualized by focusing the beam of the antenna towards a particular user only [1]. Although a smart antenna system is favorable in many ways, there are drawbacks including more complex structure and the need to develop efficient algorithm for signal tracking purpose [2–5].

Experimentally, antennas are front-end transducers, transforming free electromagnetic waves into radio frequency signals which are traveling through a shielded cable, or vice-versa [6]. Hence, the antenna alone is not smart, but rather the system in which the antenna is integrated to could add the intelligence characteristics. Normally, the smart antenna system consists of radiating antennas and digital signal processor (DSP) as a control unit [1, 7–10]. To the author's knowledge, no transceiver system has demonstrated the combination of RFID technology and reconfigurable beam steering antenna in locating and adaptively response to user's location using PIC microcontroller as a

control unit which is less complicated and cheaper than DSP.

Another prominent advantage of the proposed system lies in its mobility of the RFID tag as a device to track the location of a particular user. Conventionally, RFID technology is specially created for the security purpose. However, in this research, the capability of the RFID tag in producing certain level of signal strength has been exploited as a stimulator for the system to adaptively activate certain PIN diode switches of reconfigurable beam steering antenna. The technology is realized by two components, which are the mobile RFID tag as the transmitter and four units of low power data radio modules, (LPDRM) as the RFID readers. In [2, 11–17], RSSI is a parameter that has been used in predicting the location of a wireless device and estimating the distance traveled by a transmitted signal to reach the receiver. Instead of using complicated localization algorithm such as MUSIC algorithm [17], the mobility of the RFID tag and the ‘pyramid’ structure of the RFID readers’ antenna which has four sections with leaned at 45° angle for every single section enable the proposed system to perform the same function efficiently as an easier approach.

The RSSI signals from the RFID readers are then transferred and processed by the PIC microcontroller. The section which is directly facing the RFID tag automatically is regarded as “the tag location angle”. Indirectly, the value will lead to the location of the tag, and the PIC microcontroller will respond by activating certain configuration of PIN diodes at the reconfigurable antenna to radiate the beam towards that location. Hence, the proposed system which is developed using RFID technology, PIC microcontroller and reconfigurable beam steering antenna, is better in terms of less complexity, mobile, cheaper and remains effective compared to the conventional smart antenna system.

The paper is organized as follows: In Section 2, the system design which consists of RFID tag, PIC development board (PIDB), reconfigurable RLSA beam steering antenna and 4 units of RFID readers are explained, and the effects of pyramid configuration of the antenna are investigated. The measurement setup of the system is shown in Section 3. The results of simulation and measurement are revealed in Section 4. Finally, conclusion will be drawn in Section 5.

2. SYSTEM DESIGN

The proposed adaptive antenna is composed of four major devices such as RFID tag, PIC development board (PIDB), reconfigurable RLSA beam steering antenna and 4 units of RFID readers as shown in Figure 1. In Figure 2, the control unit which is the PIC development

board (PIDB) is developed by several electronic components such as PIC microcontroller, crystal clock oscillator, voltage regulator, latch, buffer, capacitors, transistors, diodes, resistors and liquid crystal display (LCD). The RFID readers are interfaced with the PIC microcontroller through the universal synchronous and asynchronous receiver/transmitter (USART) protocol through the input ports: A1, A4, C4 and C7 as shown in Figure 2. The protocol required to act as a medium to ensure the communication link can be realized between the two types of devices.

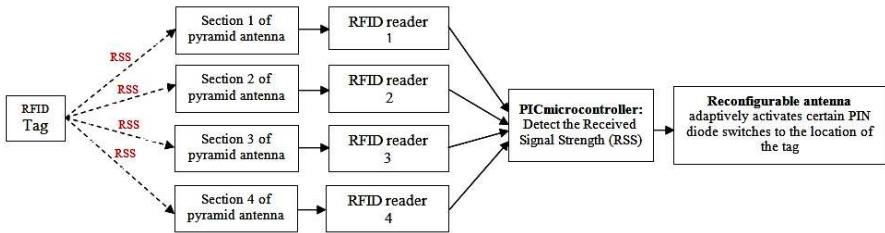

Figure 1. Framework diagram of adaptive antenna system.

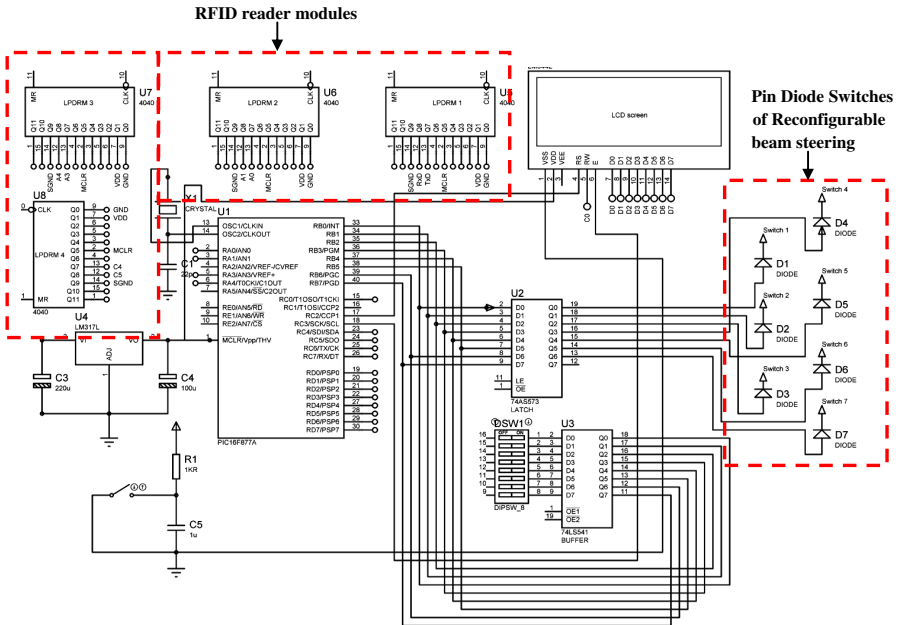

Figure 2. The schematic of the PIDB.

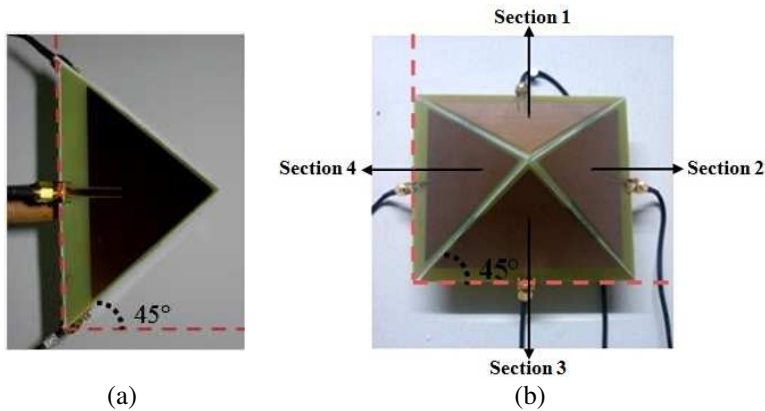

Figure 3. The ‘pyramid’ directive antenna of the RFID reader. (a) Side view. (b) Top view.

2.1. RFID Sensing Circuit

The RFID tag is a mobile wireless long distance transmitter which is able to produce the RSS signals. Meanwhile, the RFID readers act as the receiver to that signals through its directive antennas at 0.433 GHz. The four different section antennas with the four different RFID readers are combined to form a pyramid structure which makes up FR4 dielectric substrates as shown in Figure 3. Each section is designed based on 90° triangle that has the ‘adjacent’ and ‘opposition’ leaned at 45°. This configuration with Sections 1, 2, 3 and 4 enables the antennas to detect the location of the user proficiently by receiving the received signal strength (RSS) signals from the RFID tag at four different angles: 0°/360°, 90°, 180° and 270° respectively. The section which is directly facing the RFID tag is automatically regarded as the tag location angle. The RSS signals that are received by the RFID readers then transferred to the central processing unit of the PIDB which is the PIC microcontroller.

2.2. Reconfigurable Beam Steering of RLSA Antenna

In Figure 4, the RLSA antenna [1] is used as reconfigurable beam steering antenna to trace the current position of the RFID tag. The reconfigurable antenna is made of two types of switches, which are the reconfigurable beam steering switches (RBS) and reconfigurable frequency switches (RFS). In Figure 4(a), the first up to the fourth switches are the RBS, while the other switches that are not pointed

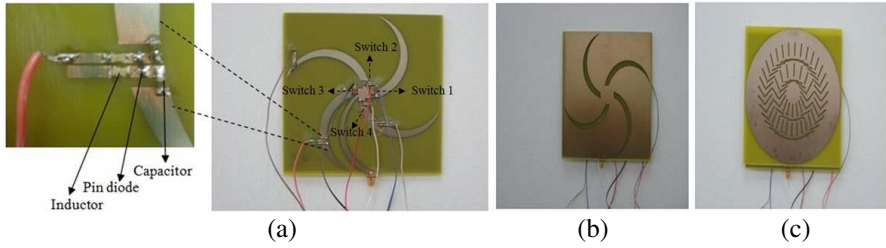

Figure 4. The reconfigurable beam steering antenna [1]. (a) Feed line with PIN diode switches. (b) Aperture slots. (c) RLSA radiating surface.

Table 1. Configuration of PIN diode switches.

Type of switch	Number of PIN diode switch	PIN diode status			
		reconfigurable beam steering switches (RBS)	i	ON	ON
	ii	ON	OFF	ON	ON
	iii	ON	OFF	OFF	ON
	iv	ON	OFF	OFF	OFF
Degree of steering beam		0°/360°	90°	180°	270°
Gain (dB)		10.15	10.4	11.8	14.2

out make up the RFS. However, research has been focusing only on the beam steering at a single frequency which is 2.3 GHz and the RFS of which no significant effects could be ignored. This antenna is capable to steer the beam from 0° up to 360° in order to detect the RFID tag as mentioned before. The RBS PIN diodes switches are connected to the output ports of PIC microcontroller through port of B0 up to port B4 as shown in Figure 2.

2.3. Measurement Setup

The prototype test is implemented by taking 50 measurements of RSS within 100 m of radius at four different angles. In this research, there are two opposite trajectories of RSS signals coming out from two different sources, the mobile RFID tag at the measurement points and reconfigurable beam steering antenna at the base station. The first trajectory occurs when the mobile RFID tag emitting certain level of RSS signals to the pyramid antenna at base station, to stimulate certain PIN diode switches of reconfigurable beam steering antenna. The beams will then steer adaptively to the location of the tag with certain RSS signals, referred as a second trajectory.

All the experiments have been carried out in Marching-Field of Universiti Teknologi Malaysia (UTM) as shown in Figure 5. These measurements can be reasonably approximated as a Ground Reflection (Two-Ray) propagation model because it involves the direct path and ground reflected propagation path since the marching field is covered by pavement with no electromagnetically significant objects between the transmitter and the receiver.

A wireless mobile spectrum analyzer produced by Rohde and Schwarz (RS) with horn antenna is deployed as a device to verify the strength of incoming signals from the reconfigurable beam steering antenna and RFID tag as shown in Figure 6. The measurements are performed at frequencies of 2.3 GHz and 0.433 GHz for reconfigurable

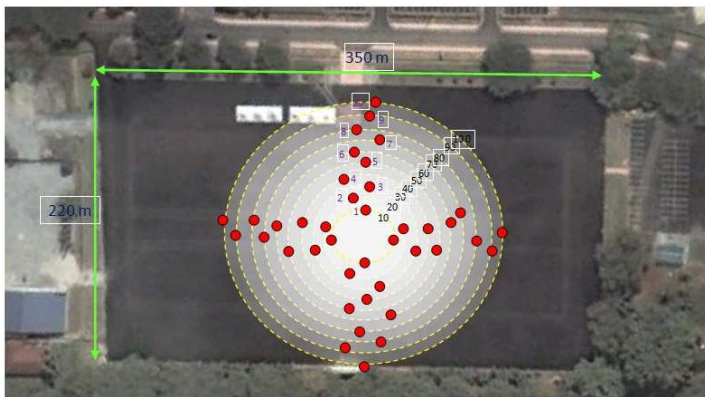

Figure 5. Measurement points (point 1 up to 10) within 100 m radius of the marching-field.

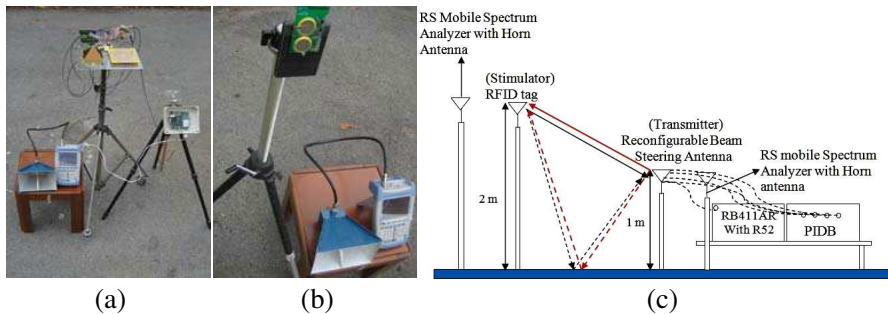

Figure 6. Measurement setup. (a) Base station. (b) Measurements point. (c) Ground reflection (two-ray) propagation model.

beam steering antenna and RFID tag respectively. All of the devices are located at the base station except the RFID tag and another RS spectrum analyzer which are located at the measurement points as shown in Figure 6(b). The beam steering antenna height is fixed at 2m above ground while the horn antenna height is fixed at 4 m above ground. The RFID tag and RS spectrum analyzer are moved to the measurement points as shown by red circular dots in Figure 5.

The expression to determine the received power or received signal strength at a certain distance from the transmitter is given by Equation (1). The value of p_t , g_t , g_r , h_t and h_r for the first trajectory is 0.01 W, 1 dB, 1 dB, 4 m and 2 m respectively. Meanwhile the value of p_t , g_r , h_t and h_r for the second trajectory is 0.075 W, 1 dB, 2 m and 4 m respectively. The value of g_t is dependent on the degree of steering beam as shown in Table 1; 10.15 dB, 10.4 dB, 11.8 dB and 14.2 dB. The p_r 's value is dependent on d .

$$P_r = P_t G_t G_r (h_t^2 h_r^2 / d^4) \quad (1)$$

where P_r = Received power, g_t = Gain of transmitting antenna, g_r = Gain of receiving antenna (Horn antenna), h_t = High of transmitting antenna, h_r = High of receiving antenna, d = Distance between the transmitter and receiver.

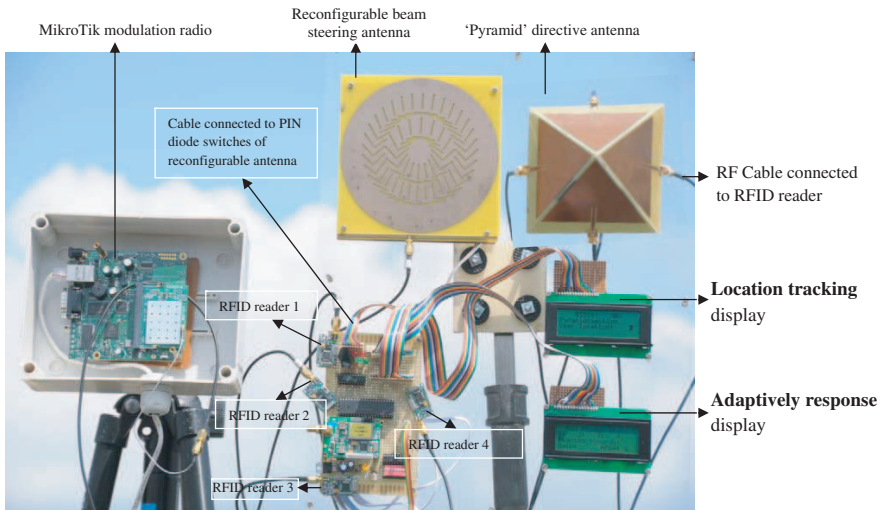

Figure 7. Adaptive antenna system at base station.

3. RESULT AND DISCUSSION

The pyramid shaped antenna of RFID reader is working at 0.433 GHz with gain of 1.6 dB as depicted by Figure 8. As mentioned earlier, this shape with Sections 1, 2, 3 and 4 allows the antenna to detect the location of the RFID tag or user at the angle of $0^\circ/360^\circ$, 90° , 180° and 270° respectively. In order to detect the RFID tag position efficiently, the pyramid antenna is designed in circular polarization. The section which is directly facing the RFID tag automatically regarded as “the tag location angle” as shown in Figure 9. At each angle, the four different sections received different levels of the RSS signal where the closer the range of the RFID tag to the base station, the higher value of the RSS signal achieved.

The difference in operating frequency and transmitting power between the RFID tag and reconfigurable beam steering antenna contributed to the different signal strength and path loss at the same measurement point. Moreover, investigation on those parameters at each measurement point and base station is crucial in finding optimum values of height and projection for both components. Hence, the mobile RS spectrum analyzer and Equation (1) are used to respectively measure and calculate both parameters. When the RFID tag is activated from point 1 up to point 10 within frequency range of 0.430 GHz up to 0.439 GHz and centered at 0.433 GHz, the measured RSS values are decreased between -44.0385 dBm down to -74.6807 dBm as shown in Figure 10(a). The measured values are then transferred to Figure 10(b) to be compared with calculated values. The

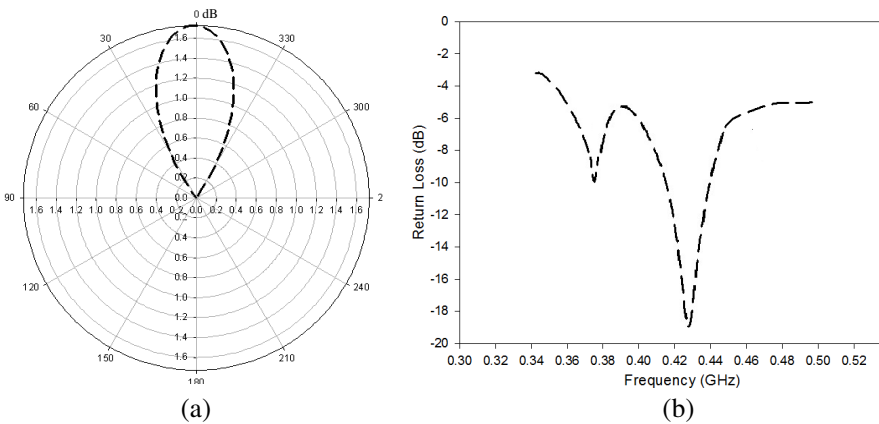

Figure 8. Measurement single section of pyramid antenna. (a) Radiation pattern. (b) Return loss.

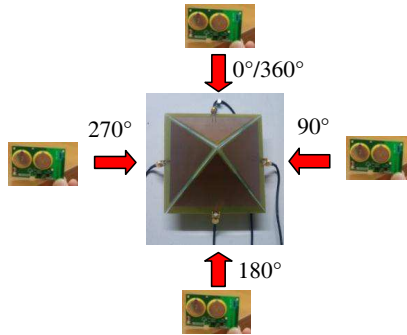

Figure 9. Detecting the location of RFID tag by pyramid antenna.

results have emphasized that the RFID tag which is deployed in the measurements is an accurate device of RSS signals over distance for Ground Reflection (Two-Ray) propagation model.

It is also shown that the pyramid antenna is capable of receiving the RSS signals efficiently from the four angles with different values at different ranges. It is worth noting that the detection of RSS signals are effectively achieved only by the 45° angle of the pyramid antenna as shown in Figure 3. Such a feature is therefore unattainable with the ordinary RFID reader antenna shapes.

The PIC microcontroller is programmed to be sensitive in detecting any changes of RSS signals received by a certain section of pyramid antenna. Consequently, when certain RSS signals ‘flow’ from a particular section into its respected modules, the range and angle of the RFID tag are automatically detected by the input ports of PIC microcontroller. Once the location of the tag is known, the PIC microcontroller responds adaptively by activating the PIN diodes of reconfigurable antenna based on Table 1 through its output port B0 up to port B4.

As a result, the beam will tailor the location of the tag, which has been verified by the RS spectrum analyzer as shown in Figure 11, Figure 12 and Figure 13. An adaptive change in the main beam radiation angle, gain and RSS of reconfigurable beam steering antenna is achievable by activating the RFID tag from a certain angle.

The reconfigurable beam steering antenna has a radiation pattern at $0^\circ/360^\circ$ with a gain of 10.15 dB, beamwidth of 60° and signal strength between -78 dBm and -70 dBm, when the RFID tag is activated at angle of $0^\circ/360^\circ$ from point 1 up to point 10 as shown by red circular dots in Figures 11(a) and 12(a). By activating the RFID tag at 90° angle, the main beam of reconfigurable antenna would then

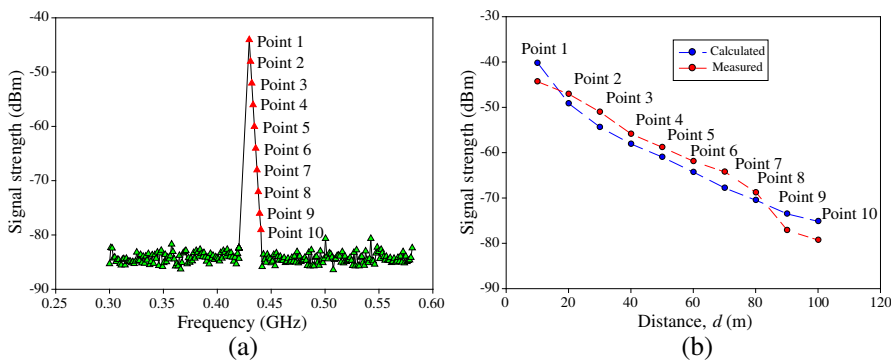

Figure 10. Measured and calculated of RSS's RFID tag at each angle. (a) Measurement with respect to the frequency. (b) Comparison between measured and calculated based on range, d .

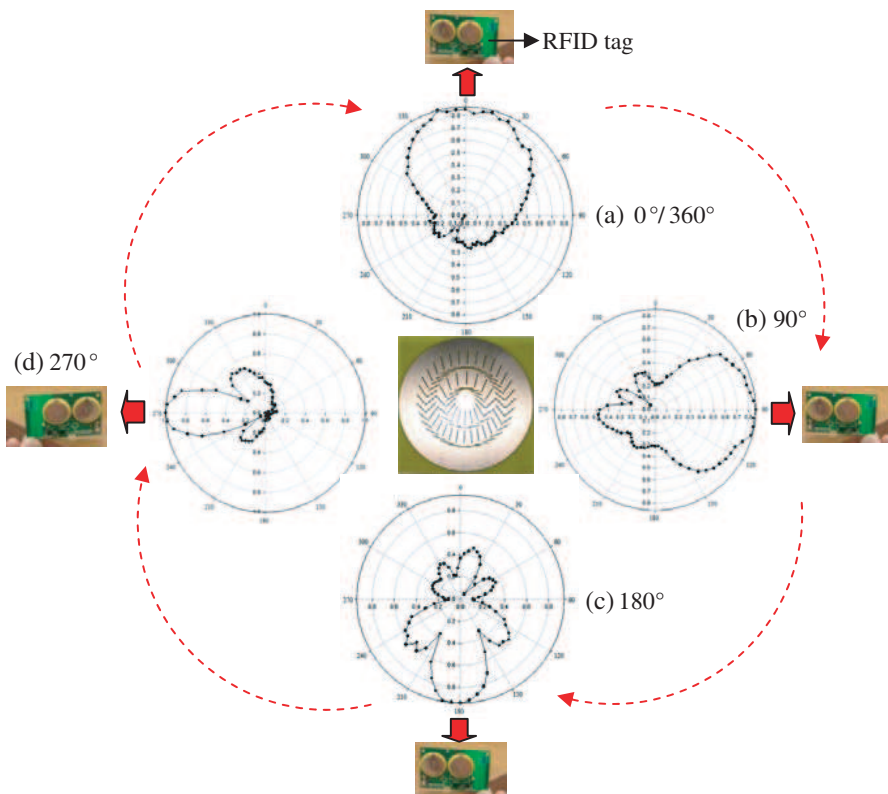

Figure 11. The measurement beam of reconfigurable beam steering antenna [1] adaptively steered to the location of the tag.

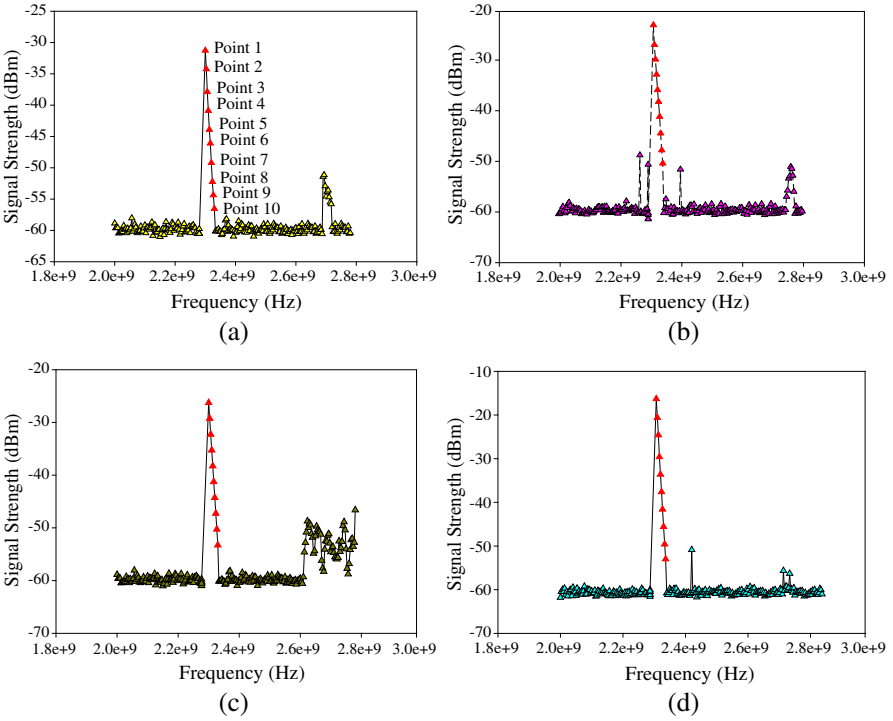

Figure 12. The RSS measurements of reconfigurable beam steering antenna over frequency. (a) 0°/360°, (b) 90°, (c) 180°, (d) 270°.

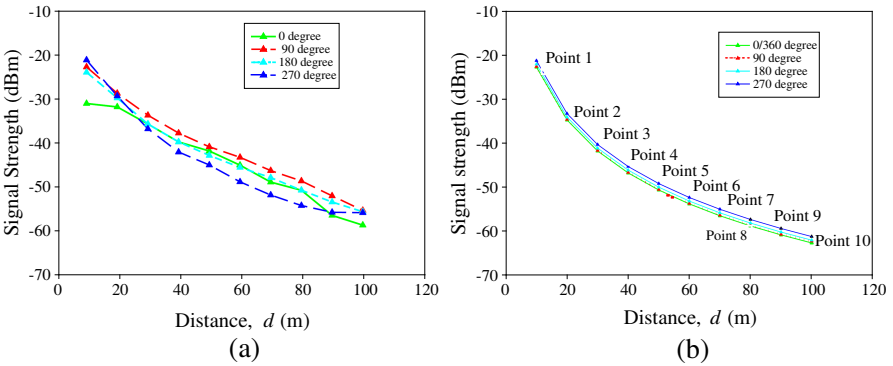

Figure 13. The signal strength of reconfigurable beam steering antenna. (a) Calculated. (b) Measured.

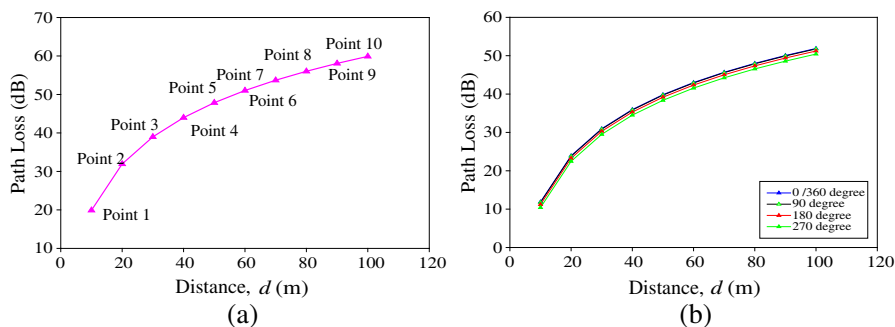

Figure 14. The calculated path loss. (a) RFID tag. (b) Reconfigurable beam steering antenna.

be adaptively steered to 90° and would have a gain of 10.4 dB as well as beamwidth of 70° and signal strength of -85 dBm to -77 dBm, as depicted by Figures 11(b) and 12(b).

Figures 11(c) and 12(c) demonstrate an increment of gain up to 11.8 dB, a narrower beamwidth of 50° with signal strength between -85 and -77 dBm, with the main beam steered to 180° by activating the RFID tag from the angle of 180° . In Figures 11(d) and 12(d), the main radiated beam is shifted to 270° with a gain of 14.2 dB, beamwidth of 30° and signal strength from -78 dBm to -70 dBm when the RFID tag is activated at the angle of 270° . The measured RSS signals are then transferred to Figure 13(b) to be compared with calculated values. All the measurements show a very good concurrence with the calculations.

4. CONCLUSION

The novel adaptive antenna system consisting of RFID technology, reconfigurable beam steering antenna and PIC microcontroller is introduced. The ability of the RFID readers in receiving the RSSI signals from the RFID tag are dependent on the shape and angle of its antennas. The 45° ‘adjacent’ and ‘opposite’ angles of four 90° triangles combined to form a ‘pyramid’ structure antenna are exploited to allow the RFID readers to receive the RSS signals efficiently from the angle of $0^\circ/360^\circ$, 90° , 180° and 270° . The diffraction has affected the four different sections to receive different levels of the RSS signals but the section directly facing the RFID tag is proven to have received the highest value of the RSS signals and automatically detect the location of the tag. Once the location of the tag is detected, the reconfigurable antenna activates certain PIN diode switches to adaptively steer its

beam towards that location. However, the capability of the beam steering antenna to cover all the measurement points of the tag is dependent on the RSS signals from the RFID tag and beam steering antenna. Even though the base station has a MikroTik modulation radio with transmitting power of 0.075 W and a beam steering antenna which has high different gains of 10.15 dB, 10.4 dB, 11.8 dB and 14.2 dB at the angles of $0^\circ/360^\circ$, 90° , 180° and 270° respectively. It is proven from the measurements that the 10 dBm transmitting power and 1 dB gain of RFID tag could produce almost the same value with 0.075 W transmitting power at base station in terms of RSS signals which is between -39.48 dBm and -75.184 dBm. The average RSS signals produced by four different angles of beam steering antenna are measured between -38.210 dBm and -70.8970 dBm. It is realized that higher operating frequency of 2.3 GHz at base station resulting higher signal losses compared to 0.433 GHz of the RFID tag. The path loss attenuations of RFID tag and beam steering antenna are laid between 19.8967 dB and 55.842 dB and between 27.874 dB and 66.682 dB respectively at the same measurement points. The capability of the mobile RFID tag in producing a comparable RSS signals with the base station is exploited as a stimulator to adaptively allow the activation of certain PIN diode switches of reconfigurable beam steering antenna. The calculated RSS signals and path loss have a good agreement with the measurements. It is also proven from the calculated RSS signals that the beamwidth of reconfigurable antenna is capable to efficiently cover the scattered measurement points of 1 up to 10 at four angles with different ranges of distance based on Ground Reflection (Two-Ray) propagation model. This clearly shows that the beams of the reconfigurable antenna have steered according to the location of the tag. The RFID technology and reconfigurable beam steering antenna have a great potential in realizing the new smart antenna system replacing the conventional adaptive array antenna for Wimax application.

REFERENCES

1. Jamlos, M. F., O. A. Aziz, T. A. Rahman, M. R. Kamarudin, P. Saad, M. T. Ali, and M. N. Md Tan, "A beam steering radial line slot array (RLSA) antenna with reconfigurable operating frequency," *Journal of Electromagnetic Waves and Applications*, Vol. 24, No. 8–9, 1079–1088, 2010.
2. Jeon, S.-S., Y. X. Wang, Y. X. Qian, and T. Itoh, "A novel smart antenna system implementation for broad-band

- wireless communications,” *IEEE Transactions on Antennas and Propagation*, Vol. 50, No. 5, 2002.
3. Tayebi, A., J. Gomez, F. Saez De Adana, and O. Gutierrez, “The application of ray-tracing to mobile localization using the direction of arrival and received signal strength in multipath indoor environments,” *Progress In Electromagnetics Research*, Vol. 91, 1–15, 2009.
 4. Seow, C. K. and S. Y. Tan, “Localization of omni-directional mobile device in multipath environments,” *Progress In Electromagnetics Research*, Vol. 85, 323–348, 2008.
 5. Song, H. B., H.-G. Wang, K. Hong, and L. Wang, “A novel source localization scheme based on unitary esprit and city electronic maps in urban environments,” *Progress In Electromagnetics Research*, Vol. 94, 243–262, 2009.
 6. Bi, S. Z. and X. Y. Ren, “Maneuvering target doppler-bearing tracking with signal time delay using Interacting multiple model algorithms,” *Progress In Electromagnetics Research*, Vol. 87, 15–41, 2008.
 7. Ouyang, J., F. Yang, S. W. Yang, Z. P. Nie, and Z. Q. Zhao, “A novel radiation pattern and frequency reconfigurable microstrip antenna on a thin substrate for wide-band and wide-angle scanning application,” *Progress In Electromagnetics Research*, Vol. 4, 167–172, 2008.
 8. Alfred, Q. M., K. Bishayee, T. Chakravarty, and S. K. Sanyal, “A dsp based study of pattern nulling and pattern shaping using transform domain window technique,” *Progress In Electromagnetics Research C*, Vol. 2, 31–45, 2008.
 9. Hyeon, S., Y. Yun, and S. Choi, “Novel automatic calibration technique for smart antenna systems,” *Digital Signal Processing*, Vol. 19, No. 1, 14–21, Elsevier, 2009.
 10. Jeon, S.-S., Y. X. Wang, Y. X. Qian, and T. Itoh, “A novel planar array smart antenna system with hybrid analog-digital beamforming,” *IEEE MTT-S International Microwave Symposium Digest*, Vol. 1, 121–124, 2001.
 11. Abdolee, R., W.-P. Zhu, and M. Sawan, “Digital beam-forming implementation for downlink smart antenna system,” *52nd IEEE International Midwest Symposium on Circuits and Systems*, 615–619, 2009.
 12. Helhel, S., Ş. Özen, and H. Göksu, “Investigation of GSM signal variation depending weather conditions,” *Progress In Electromagnetics Research B*, Vol. 1, 147–157, 2008.

13. Wu, R.-H., Y.-H. Lee, H.-W. Tseng, Y.-G. Jan, and M.-H. Chuang, "Study of characteristics of RSSI signal," *IEEE International Conference on Industrial Technology (IEEE ICIT)*, 1–3, 2008.
14. Nafarieh, A. and J. Ilow, "A testbed for localizing wireless LAN devices using received signal strength," *IEEE Communication Networks and Services Research Conference*, 481–487, 2008.
15. Bouchereau, F. and D. Brady, "Bounds on range-resolution degradation using RSSI measurements," *IEEE International Conference on Communications*, Vol. 6, 3246–3250, 2004.
16. Ridgers, T. J., C. Boucey, J.-P. Frambach, L. R. Du Roscoat, and P. Gamand, "Challenges in integrating embedded RF within a SOC," *IEEE Radio and Wireless Symposium (RWS)*, 547–550, 2008.
17. Zhang, L. and Z. Wang, "Integration of RFID into wireless sensor networks: Architectures, opportunities and challenging problems," *IEEE Proceedings of the Fifth International Conference on Grid and Cooperative Computing Workshops (GCCW)*, 463–469, 2006.