

Secured Indoor Powerline Communication Using CDMA Technique

Mohamed Sherfi Omer AbuElHassan and Razali Ngah

Wireless Communication Centre,
Faculty of Electrical Engineering
Universiti Teknologi Malaysia
81310 UTM Skudai Johor

sherfi4@gmail.com, and razalin@fke.utm.my

Abstract - With the rapid growth of home networks, there is an ongoing need for an economical and reliable communications system that can be implemented in any building. Powerline channel has been considered as a medium not only for low-rate, control communications, but also for high-speed data communications, such as home networking and Internet access. Communication over the power line has become an opportunity for the power distributors to implement new services. The focus of this paper is to address the challenges in PLC such as noise and security. The techniques to overcome these challenges are presented.

Keywords: Powerline communication, CDMA, Coupling Circuit, Security

1. Introduction

Powerline communication (PLC) is a technique which provides the ability to transfer data over standard AC wiring, uses the existing public power wiring system network to carry information. It is somehow a kind of "wireless" communication because PLC technology can supersede the installation of dedicated wiring in some applications. Various applications use PLC technology from power company equipment controlling to computer networking.

The design and implementation of interface circuit that can transfer the data within the available range will be considered, that means many applications can be used using PLC.

Powerline networking uses existing electrical wiring can be used to create a home network. Since most homes have plenty of power outlets, then this technology can be considered as an easy and eventually less expensive than other types of networking, as it is already exists.

PLC has several advantages which can lead to use it as communication channel. Using AC power lines to transmit data eliminates the cost of installing special wiring between distributed system elements and can be used for all type of communications.

2. PLC Challenges

Power lines and their associated networks are not designed for communications use. They are a hostile environment that makes the accurate propagation of communication signals difficult. The biggest challenges faced in PLC are noise, attenuation, interference and security. The main reason is that powerline where designed to deliver power not data, most design effort where only done to minimize the circuit resistance between the power injection point and the load.

Powerline is already established, therefore, many plugs installed around the building and this make powerline is unsecure. To design suitable circuits such as coupling circuit, power line modem, etc., the behaviour of powerline must be studied to avoid the above problems.

3. Indoor PLC Channel Noise

From the basic approach provided in [1] and extended in [2], powerline noise can be generally classified into three types:

1) **Colored background noise:** This noise is mainly caused by summation of numerous noise sources with low power, and also consistent with the load capacity of distributed transformer. Its power spectral density (PSD) varies over time in terms of minutes or even hours.

Figure 1 shows the best, average and worst cases of colored background noise PSD. The dynamic range was up to 40 dB over the 100 MHz bandwidth. Its feature appears to be white noise.

Generally, background noise PSD can be written as [3]:

$$N(f) = 10^{b-c \cdot f^d} \quad (\text{W/Hz}) \quad (1)$$

where b , c and d are constant and f is frequency.

The maximum, minimum and the average values for the parameters of b , c and d in equation (1) are shown below depending on measurement over 100MHZ [3]:

At maximum: $b = -55$, $c = -40$, $d = -0.4$

At minimum: $b = -85$, $c = -50$, $d = -0.6$

Average: $b = -70$, $c = -60$, $d = -0.5$

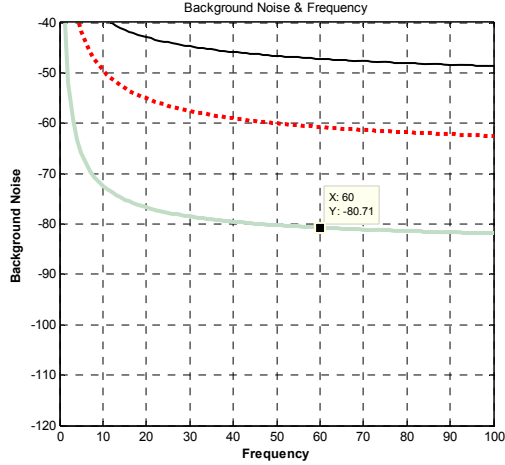

Figure 1: Maximum, average, and minimum of background noise

2) **Narrow band noise:** It is mainly produced by the horizontal scanning signals of the TV set and monitors, the peak on the power spectrum graph appears at the horizontal scanning signal and its harmonic frequency points. The repeating frequency is usually 50 to 200Hz [2].

3) **Impulse Noise-Random Pulse Noise:** It is mainly occurred when the protection switch turning off or on. Each pulse noise will affect a very broad band. Its arrival time is random, and it can last from several μs to several ms . the pulse wave shape is like damping sine wave or serried damping sine wave. Switching ON/OFF of appliances is unpredictable [1].

Figure 2 shows the sample of impulse noise with the impulse amplitude, $A = \max(A_i^+, A_i^-)$. The impulse width t_w , and the arrival time $t_{arr,i}$. The distance between two impulse events is described by the interarrival time t_{LAT} or impulse distance t_d . The distance between two impulse events is described by the t_{LAT} is given by [1].

$$t_{LAT} = t_w + t_d = t_{arr,i+1} - t_{arr,i} \quad (2)$$

The train of impulses $\eta_{imprain}(t)$ can be described by the time behaviour and given by [1],

$$\eta_{imprain}(t) = \sum_{i=1}^N A_i * \text{imp}\left(\frac{t - t_{arr,i}}{t_w, i}\right) \quad (3)$$

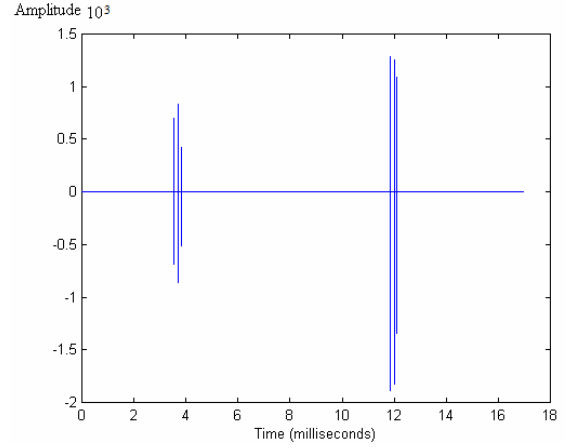

Figure 2: Impulse noise

4. Attenuation

A power line is a transmission line designed for transmitting commercial power of 50 Hz and 60 Hz frequencies, not a line designed for communications. For this reason, the signal attenuation characteristics are affected to a greater extent by cable types or wiring methods and loads connected to the cable terminals (electric equipment, wall outlets, etc.), as compared to lines of coaxial cable or twist pair cable, etc., which are used for normal wire communications.

Distance on the power line is one of the major factors in signal attenuation increases. Reflection from the terminals of branch lines on the power line also is one of the major factors in signal attenuation increases. In power lines, cable types are generally different in major lines and branch lines; therefore, they have different characteristic impedances, causing mismatching.

Basically, reflection is assumed to be related to the distance from the branch line to the terminals; however, since the number of branches and the distance vary and they are intricately combined in the actual power line configuration, as was previously stated, reflection occurs on various frequencies. When these coincide, a great amount of unexpected signal attenuation will occur on certain frequencies.

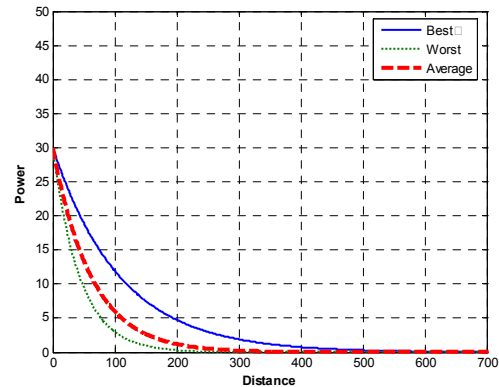

Figure 3: Attenuation

Figure 3 shows the relationship between transmitted power (P) and distance (d) at the best, average and worst channel cases. As shown in the figure the transmitted power decreases when distance increases. It's possible to avoid attenuation by increase the transmitted power.

The received signal powers, S for the best and worst case at a distance, d from the transmitter are given by [4]:

$$S_{best}(d) = P * 10^{-0.004*d} \quad [W] \quad (4)$$

$$S_{worst}(d) = P * 10^{-0.010*d} \quad [W] \quad (5)$$

5. Shannon's Theory for the Powerline Channel

The ability to transfer data can be estimated for a channel with knowledge of the essential used in Shannon's formula,

$$C = B * \log_2 \left(1 + \frac{S}{N} \right) \quad (6)$$

C indicates the maximum data rate in (bits/s) for which a theoretically error-free transmission is possible normally cannot be achieved by technically realizable and also profitable systems in practice. i.e., the use of [8] is not immediately feasible for powerline channels, since the signal to noise ratio is not constant within the bandwidth B , but may vary substantially. In practice therefore the transmitted signal-power density spectrum $S_{rr}(f)$ and a frequency-dependent noise-power spectral $S_{nn}(f)$ density must be taken into account, so that equation (6) has to be modified as follows [2]:

$$C = \int_{f_u}^{f_0} \log_2 \left(1 + \frac{S_{rr}(f)}{S_{nn}(f)} \right) df \quad (7)$$

$$\text{where } \int_{f_u}^{f_0} = B$$

In order to be able to use equation (7) the transmission power density spectrum $S_{tt}(f)$, the channel transfer function $H(f)$ as well as noise power density spectrum $S_{nn}(f)$ receiver should be determined. The received signal power density spectrum is then:

$$S_{rr}(f) = S_{tt}(f) * H(f)^2 \quad (8)$$

$$S_{tt}(f) = \frac{E(f)^2}{K(f,d)^2 * B} \quad (9)$$

where E is electrical field strength, and B is available band width, $K(f,d)$ is decoupling factor.

Now it is possible to calculate $S_{tt}(f)$, $S_{nn}(f)$ and also C depending on system components parameter such as available bandwidth.

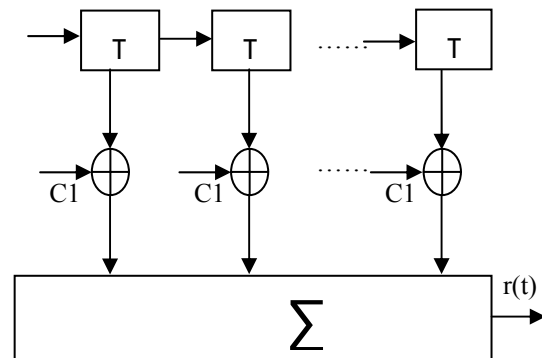

Figure 4: Basic structure of echo-model definition

Figure .4 shows the echo model that affect by the echo delay and attenuation. The basic behaviour of a transmission channel incorporating N echoes can be described by an impulse response [2]:

$$h(t) = \sum_{i=1}^N c_i * \delta(t - \tau_i) \quad (10)$$

where the coefficients τ_i denote the echo delays

and the factors c_i is the echo attenuation.

From Figure 4, the transfers function can be rewrite as,

$$h(t) = \sum_{i=1}^N c_i * e^{-j2\pi f \tau_i} \quad (11)$$

6. Coupling Circuit

To be able to design an optimum coupling circuit, appropriate components must be chosen and their operation must be understood. The components of the coupling circuit are:

(1) *Coupling capacitors* [5]: These are extensively used in power line communications, most commonly to couple the PLC signal to the power line but also as a part of more sophisticated, higher-order filters. Coupling capacitors carry the communication current and thus have to be high-frequency capacitors (self-resonant frequency has to be higher than the modulation frequency). Conversely, they have to filter the power voltage (dropped across the component), as well as voltage surges and therefore need to be high-voltage capacitors.

(2) *Isolation transformer*: used to isolate high voltage.

Coupling circuit is as a protecting circuit used as interface circuit between powerline and modem circuit. The common LC high pass filters must have some large inductive components when they are working at lower frequencies. In order to

eliminate the filter itself to produce some harmonic intermodulation products, the RC- type high pass filter is adopted [6].

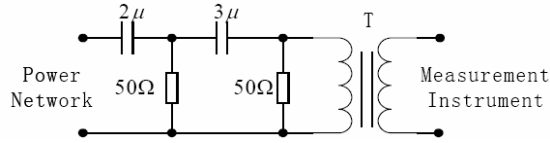

Figure 5: Coupling Circuit

Figure 6 shows the signal of powerline before coupling by applying 1 kV, 60 Hz:

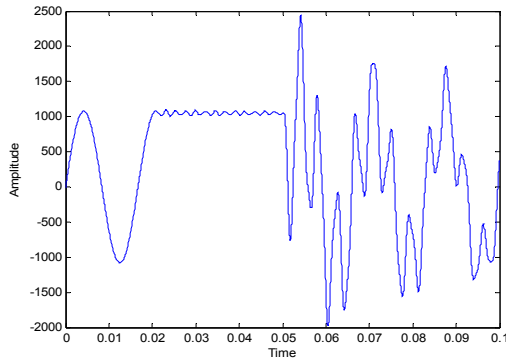

Figure 6: Powerline signal before coupling circuit

Figure 7 shows the powerline signal after coupling. It shows that the coupling circuit has successfully removed the AC voltage.

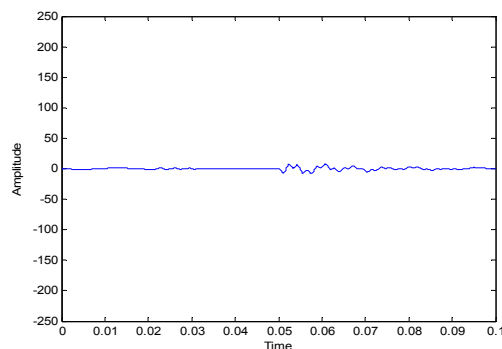

Figure 7: Powerline signal after coupling circuit

7. FSK Modulation

Frequency shift keying (FSK) modulation is a form of FM modulation where the frequency of the carrier wave is varied by the binary input stream. As the binary input signal changes from a logic 0 to a logic 1, and vice-versa, the FSK output shifts between two frequencies: a mark or logic 1 frequency and a space, or logic 0 frequency.

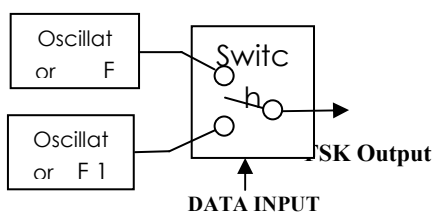

Figure 8: DPFSK schematic

Here, the discontinuous-phase frequency-shift keying (DPFSK) is chosen for modulation in simulation. Equation (12) and (13) give the expression of the DPFSK output signal and Figure 8 shows the schematic of the DPFSK as described in [7], where is called the mark (binary 1) frequency and is called the space (binary 0) frequency.

$$S(t) = A_c[w_c + \theta(t)] = S(t) = A_c[w_1 + \theta_1] \quad (12)$$

for t in the time interval when a binary 0 is being sent

$$S(t) = A_c[w_c + \theta(t)] = S(t) = A_c[w_2 + \theta_2] \quad (13)$$

for t in the time interval when a binary 1 is being sent.

Figure 9 shows the DSFSK output using Matlab simulink:

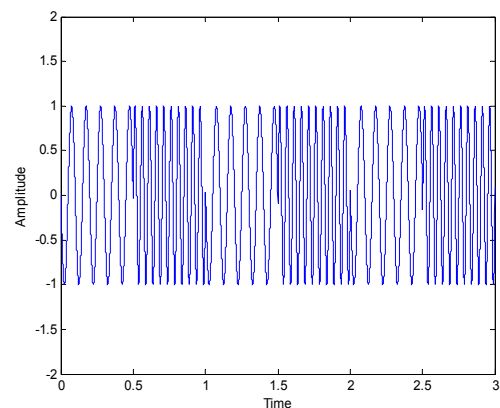

Figure 9: FSK Output

8. Spread spectrum Techniques DS-CDMA

The investigations show that the powerline must be regarded as a slightly time-variant and frequency-selective channel. These properties will have an effect on the selection of a suited transmission scheme. The main problem that powerline is already established within the buildings, and there are many plenty's (plugs) distributed around the building, and this will cause a big problem.i.e.if computer network is used over indoor powerline, that means any one can access this network.

All these reasons lead to a system design which is based on the spread spectrum technique to overcome the mentioned problems. By spreading the signal over a wide frequency range is that the influence by jammers with small bandwidth is very low. By using DS-CDMA or direct sequence spread spectrum,data will be more secure. With direct sequence spread spectrum (DSSS), each bit in the signal represented by multiple bits in transmitted signal, using spreading code spread the signal across a wider frequency band in direct

proportion and this code generated by pseudorandom noise [7].

Figure 10 shows DSSSS using PN code: (11011).

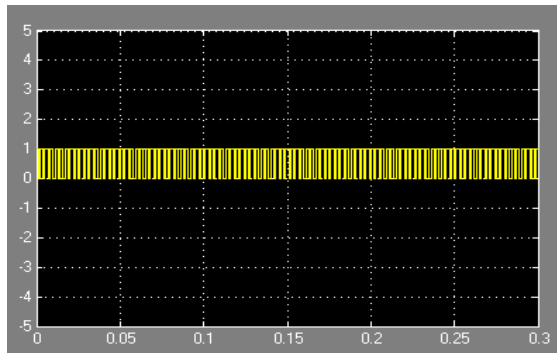

Figure 10: Pseudorandom code

By using FSK modulation as first modulation, the FSK output will be the input to the DSSS.

Figure 11 shows the FSK spreading signal by using DSSSS .i.e, DSSS output:

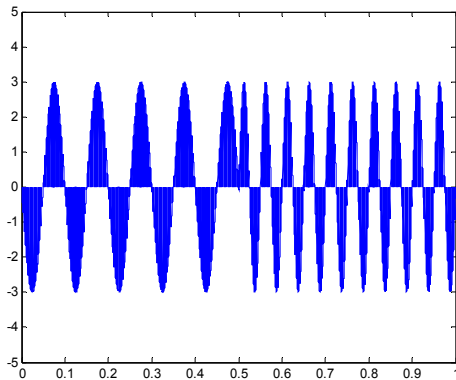

Figure 11: FSK spreading signal

9. Error Control Methods

To avoid the signal errors, the coupling circuit and high pass filter is not enough, because there are some errors can be detected duo to impulse noise and other factors, therefore error control will be good solution beside the other components.

Forward Error Correction (FEC) is used to detect and correct errors at the receiving end without calling for retransmission. With FEC, a number of bits are added to the message. These extra bits are coded in a way that allows for a certain number of errors per message to be detected and corrected.

10. Summary

Due to the inherent characteristics of the low-voltage power line, the transmitted signal is seriously polluted for the influence of noise, attenuation. In this paper, the optimized methods to enhance the communication reliability of the low-voltage PLC have been presented. A method for DSFSK modulation also has been presented. The

method is uncomplicated, fast and easy to implement, thus it is suitable for low-cost architectures, eliminating the need for high-speed processing hardware. The demodulation method is also direct.

The application of spread spectrum technology has been presented, which is effective in improving the noise-resisting ability of the communication system. And also solved the major problem of powerline by using pseudo noise random to make it secure. Decreasing of the spread spectrum carrier frequency band of the circuits used and the amplification of transmission power can effectively counter line attenuation. Effective coupling circuit has been presented to withstand 220v-50/60Hz and also some noises. FEC used to detect and correct the errors can be detected due to impulse noise; also channel capacity has been discussed. By using high frequency above 1MHz up to 30 MHz the noise and also interference can be overcome.

11. References

- [1] Manfred Zimmermann and Klaus Dostert "Analysis and modeling of impulsive noise in broad-band powerline communications," *IEEE Trans. Electromagn. Compat.*, vol. 44, no. 1, pp 249-258, Feb. 2002.
- [2] Halid Hrasnica, Abdelfatteh Haidine, Ralf Lehnert, *Broadband Powerline Communication Networks*, John Wiley, 2004.
- [3] T. Esmailian, P. Gulak, and F. Kschischang, "A discrete multitone power line communications system," Proc. of ICASSP '00. vol. 5, pp. 2953 – 2956, Jun. 2000.
- [4] X H Zhang, L Y Zhang, B Zou and Z L Du *The Design of Virtual Low-Voltage Power Line Noise Generator*, IOP Publishing Ltd, 2006.
- [5] Osama Bilal, Er Liu, Yangpo Gao and Timo O. Korhonen "Design of broadband coupling circuits for powerline communication," in *Proc. of ISPLC Zaragoza*, Spain, 2004.
- [6] Yang Xiaoxian, Zheng Tao, and Zhang Baohui, "Measurement and research of channel noise distributed characterization in low voltage networks," in *Proc. of Transmission and Distribution Conference and Exhibition: Asia and Pacific Dalian*, China, 2005.
- [7] William Stalling, *Data and Computer Communication*, Prentice Hall, 2004.
- [8] Mohammad Sharawi "Codes and Modulation for spread spectrum and broadband wireless communications," M. Sc. Thesis, Oakland University, US, 2002.