

MODELLING AND OPTIMIZATION OF *EURYCOMA LONGIFOLIA* WATER EXTRACT PRODUCTION

A. ATHIMULAM¹, S. KUMARESAN^{2*}, D. C. Y. FOO³, M. R. SARMIDI¹ and R. A. AZIZ¹

¹Chemical Engineering Pilot Plant (CEPP), Universiti Teknologi Malaysia, Johor, Malaysia

²School of Engineering and Information Technology, University Malaysia Sabah, Sabah, Malaysia

³School of Chemical and Environmental Engineering, University of Nottingham (Malaysia Campus), Selangor, Malaysia

Eurycoma longifolia or Tongkat Ali water extract is a valued product in the phytochemical industry. This work features the modelling and optimization of a Tongkat Ali water extract production using SuperPro Designer[®], a commercial batch process simulator. The objective of this work is to design an economically viable production scheme for a locally developed Tongkat Ali extract production process. The current pilot scale production scheme with an annual production rate of 390 kg of Tongkat Ali extract was used to simulate the base case process. Four alternative production schemes were further developed with several debottlenecking and optimization strategies. The final alternative scheme was reported to achieve a product yield of 3.00%, with an annual production of 1137.72 kg of Tongkat Ali extract. The minimum batch cycle time was reduced from 24.44 h in the base case to 8.32 h. Economic analysis determined that the proposed alternative production scheme has an annual revenue of \$6.32M, with a 86% gross margin and a 55% return on investment (ROI). The payback period of this scheme was estimated to be less than two years.

Keywords: phytochemical processing; process simulation; optimization; batch processes; process debottlenecking; economic analysis.

INTRODUCTION

Eurycoma longifolia or more commonly known as Tongkat Ali, is a tropical herbal plant found in several parts of South East Asia such as Malaysia, Indonesia, and Vietnam. Locally it is also known as Payung Ali, Penawar Pahit, Setunjang Bumi, Bedara Pahit, Tongkat Baginda, Pokok Syurga, Tongkat Ali Hitam, Pokok Jelas and Jelaih. There are four different species of Tongkat Ali plant, namely *Eurycoma longifolia*, *Eurycoma apiculata*, *Polyathia bullata* and *Goniothalamus sp.* (Aziz *et al.*, 2003). Among the four, *Eurycoma longifolia* is the most commonly used species for the extract production. This plant bears fruit after 2½ years of cultivation while the root is usually taken to be processed after 4 years of cultivation.

Traditionally, Tongkat Ali is used for its aphrodisiac, anti-pyretic and anti-malarial effects as well as a general tonic (Kuo *et al.*, 2003). A decoction of its long woody tap root is taken orally. The benefits of the roots of Tongkat Ali include restoring energy and vitality, enhancing blood flow and functioning as a herbal ingredient for women

after child birth (Ismail *et al.*, 1999). The leaves cure malaria, ulcers, syphilis and gonorrhoea, prevents gum diseases, and relieves insect bites (Adenan, 2003).

The herbal-based phytochemical industry is a new and upcoming industrial sector in Malaysia. Common phytochemicals or herbal products in the market include Tongkat Ali, Misai Kucing (*Orthosiphon stamineus*) and Hempedu Bumi (*Andrographis paniculata*) extracts. Misai Kucing can be used for kidney related and joint ailments while Hempedu Bumi is used for its anti-diabetic and anti-hypertensive properties (Aziz *et al.*, 2003). Due to the high market demand and their medicinal effects, these phytochemical products have a high commercial value in the local and global market (Aziz *et al.*, 2003). For instance, Tongkat Ali water extracts can be sold for up to USD26 per bottle of 60 capsules, which is equivalent to USD8700/kg extract (Kaur *et al.*, 2003).

However, a common pitfall associated with this industrial sector is that the production of these phytochemicals (such as Tongkat Ali water extract) is mainly carried out through various traditional methods (e.g., boiling or soaking) which often lead to high losses and low product yield. Hence more effort is needed to develop this 'backyard' industry into a viable and profitable industrial sector. Various engineering contribution and practises are needed for this transformation. This includes the various

*Correspondence to: Mr S. Kumaresan, School of Engineering and Information Technology, University Malaysia Sabah, Locked Bag 2073, 88999 Kota Kinabalu, Sabah, Malaysia.
E-mail: shiva@ums.edu.my

stages of phytochemical processing, e.g., planting and harvesting, raw material preparation, processing as well as value added production (Aziz *et al.*, 2005). Engineering practices such as processing (extraction) technology, process synthesis and optimization, and product formulation hence play important roles in ensuring the 'modernization' of phytochemical industry to be successful (Aziz *et al.*, 2005).

This work presents the use of a batch process simulator in modelling and optimizing a locally developed process for Tongkat Ali water extract production. It aims to develop an economically viable production scheme via the use of computer aided process design (CAPD) and simulation tools. CAPD and simulation are important tools in the process industries since the late 1960s. It involves the use of computers to perform steady-state heat and mass balancing and sizing and costing calculations for a process (Westerberg *et al.*, 1979). However, this tool is still relatively new to the field of bio-related process engineering (Shanklin *et al.*, 2001), such as that in the biochemical and phytochemical industries. Works on bio-related process modelling and simulation were only found in the last decade (Petrides, 1994; Petrides *et al.*, 1995; Ernst *et al.*, 1997; Evangelista *et al.*, 1998; Rouf *et al.*, 2001).

In this work, SuperPro Designer[®] v6.0 (Intelligen, 2005), a commercial process simulation tool, is used to develop an economically viable scheme for the production of Tongkat Ali water extract. SuperPro Designer[®] is a window-based simulation software for modelling biochemical, food, pharmaceutical, specialty chemical, as well as other continuous and batch manufacturing processes. The base case simulation model is based on the current operating condition of a pilot scale production at Chemical Engineering Pilot Plant, Universiti Teknologi Malaysia (CEPP, UTM). To achieve industrial scale production, it is important to consider the various process and scheduling bottlenecks in the current production setup. Four alternative production schemes were further developed in the simulation model by incorporating various debottlenecking strategies to overcome the current process limitations. Value added steps were introduced to produce a final Tongkat Ali extract product of higher commercial value. Results reveal that the industrial scale production scheme is of good economic performance, with a return on investment (ROI) figure of 55% and a payback period of approximately two years.

PROCESS DESCRIPTION

Figure 1 shows the process flow diagram of a pilot scale production of *Eurycoma longifolia* water extract developed and operated at CEPP, UTM. The two main processing steps in this water extract production consists of the two stage counter-current solid-liquid extraction (leaching) process as well as the spray drying operation. The current process is operated at a batch throughput of 40 kg of ground Tongkat Ali root, which is supplied in chip form. The processing steps are explained in detail as follows.

In the first operating step, the two stage counter-current solid-liquid extraction process, fresh ground Tongkat Ali root chips are sent to the extraction vessel to be extracted using the solvent of boiled water. The ratio of water volume to the root chips weight is maintained at 6 L: 1 kg. In the first stage of extraction, Tongkat Ali roots are

boiled with fresh water (or recycled water for the second batch and above) at a temperature range of 110–120°C. This boiling operation is maintained for 2 h to provide sufficient time for the phytochemicals in the root chips to be leached into the extraction solvent (water).

Upon the completion of the first stage of extraction the extracted liquid is pumped and stored in a holding tank to be later sent for spray drying. The leftover chips are then extracted again using fresh solvent in the second stage of extraction with the same operating conditions as the first extraction stage. Upon the completion of the second stage extraction the solvent is removed and stored for reuse in the following batch and the leftover chips are discharged. Approximately 35% of the solvent (water) is absorbed in the discharged chips and this is taken as process losses.

The extract from the first extraction stage is sent to the spray dryer operated at 170°C to produce Tongkat Ali extract powder. Due to the limitation of the spray drier capacity (a feed rate of 7 L h⁻¹ of spray liquid), the drying operation takes approximately 22 h to complete. Spray drying is widely used in most herbal-based phytochemical processing to produce extract powders, mainly due to its relatively shorter process time and lower process economics, as compared to other product drying techniques such as freeze drying. In the current production scheme, the spray dried extract powder is sold as the final product in bulk form.

In this pilot scale production, the overall process yield of Tongkat Ali extract is estimated at 3.0 wt%. A detailed simulation has been performed to model the production and to assess the annual process throughput as well as its economic performance, as described in the following section.

BASE CASE PROCESS SIMULATION

In the development of the base case simulation model (Figure 2), user-defined components were approximated within the simulator database due to the absence of Tongkat Ali substances in the simulator component database. This includes the Tongkat Ali root chips, fibre, residue and extract. Due to the nature of the process that is operated in batch mode, the base case simulation model was developed to reflect the actual operating condition of the process. In the modelling environment of SuperPro Designer[®], this involves the modelling of a few *operations* that take place sequentially in a single *unit procedure* (Intelligen, 2005). For instance, vessel procedure P-1 in the Extraction section of Figure 2 was used to model the first stage of extraction process that consists of sequential operations of raw material charges, material heating, extraction process as well as product discharge. All these individual operations took place in the single vessel of V-101. The modelling of these single operations is described next.

The first operation in P-1 involves the charging of the raw material, i.e., 40 kg of ground Tongkat Ali root chips (denoted as 'TA root' in Figure 2) into the extraction vessel. Extraction solvent charging is the next subsequent operation in the procedure. As mentioned earlier, the solvent for the first extraction stage mainly consists of the recycle water (denoted as 'R.water') from the second stage of the extraction process. After the transferring of recycle water has taken place, 30 L of fresh water is next charged into P-1 as solvent make-up, to supplement the losses of

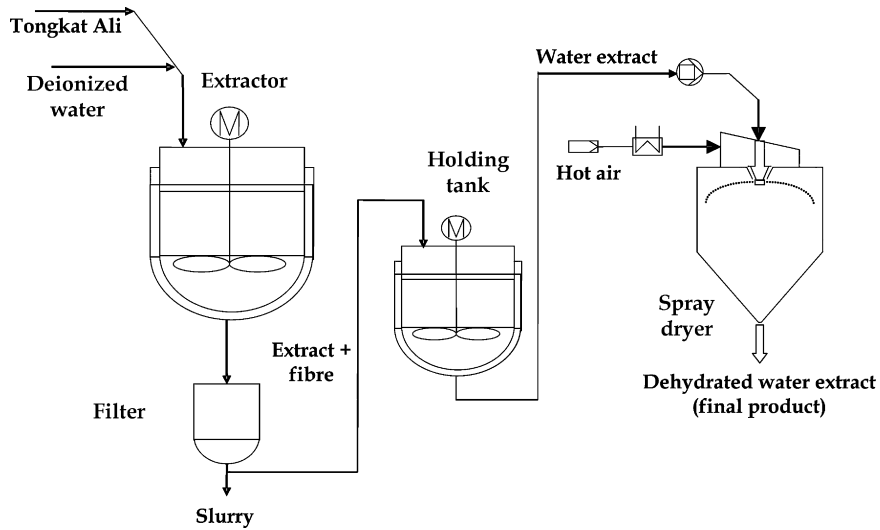

Figure 1. Process flow diagram of pilot scale Tongkat Ali water extract production.

recycle water in the solid residue from the extraction process. The operation that follows is the heating of solvent-root mixture from room temperature to 110°C. The extraction process was assumed to take place at the beginning of the heating operation. The extraction vessel was maintained at 110°C for 2 h. Based on the product yield of 3.0 wt% in the pilot scale operation, Tongkat Ali extract produced in the extraction vessel was determined as 1.2 kg per batch of extraction operation.

Upon the completion of the extraction process, the resulting extract-water and solid mixture was sent to the

centrifugation procedure P-2, that took place in the Bowl Centrifuge BC-101. This procedure is used to model the siphon system in the current pilot plant production scheme for the removal of wood chips from the effluent of extraction vessel V-101. In modelling the centrifugation procedure P-2, complete removal is set for the Tongkat Ali fibre (denoted as ‘TA fibre’); while 35% removal for extract–water mixture to represent the product losses. The remaining extract–water mixture (denoted as ‘Ext. water’) is transferred to be temporarily stored in the storage procedure P-5 (in vessel V-103 in Drying section).

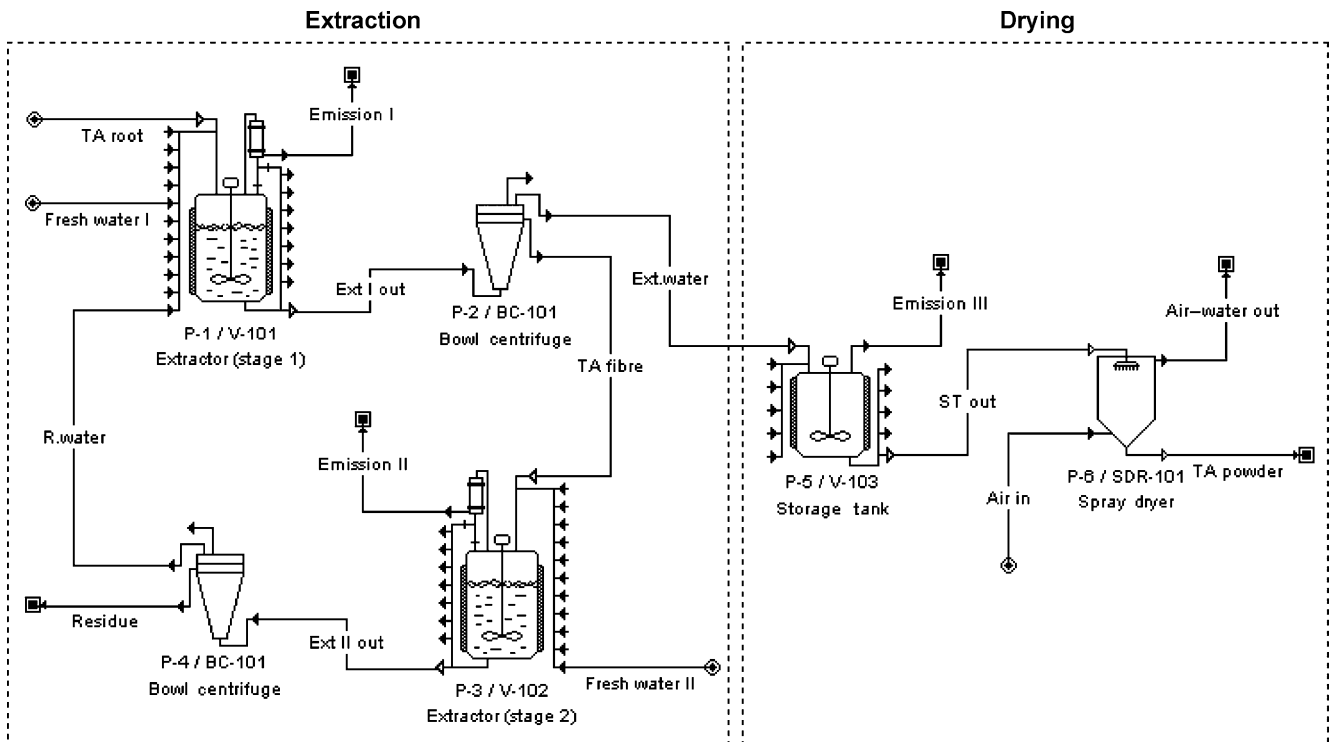

Figure 2. Simulation flowsheet for base case process.

The separated solids from P-2 are transferred into vessel procedure P-3 (in V-102) to undergo the second stage of the extraction process. The operating condition for the second stage of the extraction process is the same with that in the first stage in procedure P-1. Note that due to the counter-current mode of extraction process, 240 L of fresh water is fed at this second stage of extraction process. Product yield at this stage is assumed at 1%. The effluent from vessel procedure P-3 is separated by the centrifugation procedure P-4, which utilizes the same equipment of BC-101 in procedure P-2. The extract water leaving P-4 is recycled to P-1 (in stream 'R.water') while the solid content leaves as process residue. The operating parameter for this procedure was also set to be the same with that in procedure P-2.

Upon the completion of extract mixture transfer-in operation of P-5, the stored extract-water mixture is sent to the spray drying procedure (P-6/SDR-101) at a flowrate of 0.12 L min^{-1} (equivalent to a feed rate of 7 L h^{-1} of spray liquid). Ambient air is heated to 170°C before it is fed into SDR-101 as the drying medium. Hot air and evaporated water vapour is emitted from the top stream of SDR-101 while TA powder leaves at the bottom stream at 70°C . It is assumed that 1% of the Tongkat Ali extract is lost together with the emitted air. Upon the completion of the spray drying operation, spray dryer SDR-101 undergoes a cleaning-in-place operation, which is the last operation for the complete batch recipe for the Tongkat Ali extract production.

As the manufacturing process is carried out in batch operation, efforts have been made to document the scheduling details of each processing steps. This includes the *setup time*, *process time*, and *start time* of each individual operation in each unit procedure. Setup time (SUT) is the preparation time needed before an operation takes place. Often, this involves the loading of raw material (e.g., from loading area), equipment preparation or setup that often occur in batch processing. Process time (PT), on the other hand, represents the actual processing duration needed for each operation. Finally, start time (ST) documents the beginning of an operation. The details of this scheduling summary are shown in Table 1, with the Operation Gantt Chart shown in Figure 3.

Note that the process time for certain operations are dependant upon other operations of the same or different procedure. In SuperPro Designer[®], this inter-dependency of operation durations is termed as the Master-Slave Relationship (Intelligen, 2005). For example, the transfer in operation of recycle water (R.water) in procedure P-1 (termed as the *slave* operation) is set to follow the duration of centrifugation operation in procedure P-4 (termed as *master* operation).

Process throughput analysis is next performed on the base case simulation model. The model reports an overall product yield of 3.02%, with the batch production of 1.21 kg Tongkat Ali extracts. Based on the annual operating time of 7920 h and minimum cycle time of 24.44 h, the annual production for the process model is calculated as 323 batches. This corresponds to 390.73 kg of Tongkat Ali extract produced per annum. Currently this production rate is not sufficient for present local demand and increasing international orders.

Preliminary economic analysis is also conducted on the base case model. The raw material price for the case study

includes the Tongkat Ali root chips purchased at a price of \$6.55/kg and fresh water supplied at 0.06 cent/kg while the final product of bulk Tongkat Ali powder is sold at a price of \$660/kg. Results reveal that the current production scheme has relatively high capital (assuming that all process equipment are newly purchased) and operating cost (a break down of annual operating cost is shown in Table 2) as compared to its annual revenue. A negative value is reported for gross margin of the model and its return on investment (ROI) is as low as 5.35% compared to the minimum preferred ROI value of 30%. Hence efforts are needed to improve the economic performance of the production scheme for a more economically viable production.

BOTTLENECK IDENTIFICATION STRATEGIES

In order to increase the process throughput, one will have to identify the process bottleneck that limits the current production. Bottlenecks are process limitations that are related to either equipment or resource such as demand for various utilities, labour, raw material, and so on. In batch manufacturing, two types of process bottlenecks can be identified, i.e., size bottleneck and scheduling bottleneck.

Similarly, for batch processes, equipment utilization can be measured through its capacity utilization and equipment uptime (Koulouris *et al.*, 2000; Petrides *et al.*, 2002). Capacity utilization is defined as the fraction of equipment's capacity used during an operation while equipment uptime is the measure of how effective a piece of equipment is utilised in time. The product of equipment capacity utilization and its uptime defines the combined utilization of the respective equipment. This measures how certain equipment utilised its capacity (size) and uptime (Koulouris *et al.*, 2000; Petrides *et al.*, 2002). The processing step with the highest combined utilization is in general the first candidate equipment to become process bottleneck.

Figure 4 shows the Throughput Analysis Chart that displays capacity utilization, equipment uptime and combined utilization for each procedure/equipment pair. As shown, the spray drying procedure (P-6/SDR-101) is identified as the process bottleneck due to its highest combined utilization. The capacity utilization of this procedure has reached its maximum of 100% (due to the limitation of its feed flowrate of 0.12 L min^{-1}); while its equipment uptime is relatively high (drying operation duration of 22.11 h, Table 1). P-6 can also be classified as the process scheduling bottleneck which limits the annual production of 323 batches per year. Hence, in order to increase the annual production, debottlenecking strategies should focus on the reduction of the drying operation time which will enable more batches to be produced annually.

DEBOTTLENECKING SCHEMES TO INCREASE PRODUCTION AND IMPROVE PROFITABILITY

The previous section determined that the current production of Tongkat Ali extract powder is economically infeasible due to the low revenue generated by the low annual production rate. However efforts to increase production were limited by the process scheduling bottleneck, i.e., spray drying procedure of P-6/SDR-10. Three

Table 1. Scheduling summary for base case model.

Procedure	Operation	Process scheduling	Remarks
P-1/V-101	Charge TA root (CHARGE-TA)	SUT = 10 min PT = based on mass flowrate of 2.5 kg min ⁻¹ ST = beginning of batch	Preparation of Tongkat Ali root chips from storage Manual charging
	Transfer in R.water (TRANS-IN-R.H2O)	SUT = 10 min PT = based on Master-slave Relationship with P-4 ST = after CHARGE-TA ends	Pipe fixing and to avoid overlapping R.water recycle stream fed from P-4
	Charge in fresh water (CHARGE-H2O)	SUT = 10 min PT = based on volumetric flowrate of 4.8 L min ⁻¹ ST = after TRANS-IN-R.H2O ends	Pipe fixing, manual start-up Fresh water charge in as make-up solvent
	Heat (HEAT-1)	SUT = 5 min PT = 30 min ST = after CHARGE-H2O ends	Manual start-up Final temperature = 110°C
	Extraction (EXTRACT-1)	PT = 2 h ST = starts with HEAT-1	First stage of counter-current leaching process Leaching is assumed to start when the root chips contact with solvent
	Transfer out extraction mixture (TRANS-OUT-1)	SUT = 10 min PT = Master-slave Relationship with P-2 ST = after EXTRACT-1 ends	Pipe fixing, manual start Extraction mixture is transferred to P-2
	P-2/BC-101	Solid liquid separation (CENTRIFUGE-1)	SUT = 10 min PT = 2 h ST = starts with TRANS-OUT-1 in P-1
P-3/V-102		Transfer in TA fibre (TRANS-IN-TA-FIBRE)	SUT = 10 min PT = Master-slave Relationship with P-2 ST = starts with CENTRIFUGE-1 in P-2
	Charge in fresh water II (CHARGE-H2O)	SUT = 10 min PT = based on volumetric flowrate of 4.8 L min ⁻¹ ST = after TRANS-IN-TA-FIBRE ends	Manual start-up Fresh solvent is fed
	Heat (HEAT-1)	SUT = 5 min PT = 30 min ST = after CHARGE-H2O ends	Manual start-up Final temperature = 110°C
	Extraction (EXTRACT-1)	PT = 2 h ST = starts with HEAT-1	Second stage of counter-current leaching process
	Transfer out extraction mixture (TRANS-OUT-1)	SUT = 10 min PT = Master-slave Relationship with P-4 ST = after EXTRACT-1 ends	Manual start-up Extraction mixture is transferred to P-4
P-4/BC-101	Solid liquid separation (CENTRIFUGE-1)	SUT = 10 min PT = 2 h ST = starts with TRANS-OUT-1 in P-3	Manual start-up Solids separation from P-3 effluent
P-5/V-103	Transfer in Ext. water (TRANS-IN-1)	SUT = 10 min PT = Master-slave Relationship with P-2 ST = starts with CENTRIFUGE-1 in P-2	Manual start-up Extract-water transfer from P-2
	Temporary storage (STORE-1)	PT = 2 h ST = starts with TRANS-IN-1	Stores liquid for P-6 feed
	Transfer out storage product (TRANS-OUT-1)	SUT = 20 min PT = based on volumetric flowrate of 0.12 L min ⁻¹ ST = after STORE-1 ends	Manual start-up Based on the feed flowrate of P-6
P-6/SDR-101	Spray drying (DRY-1)	SUT = 20 min PT = 22.11 h ST = starts with TRANS-OUT-1 of P-5	Manual start-up, fixing Production of Tongkat Ali extract powder
	Chamber cleaning (CIP-1)	PT = 15 min ST = after DRY-1 ends	Cleaning of SDR-101

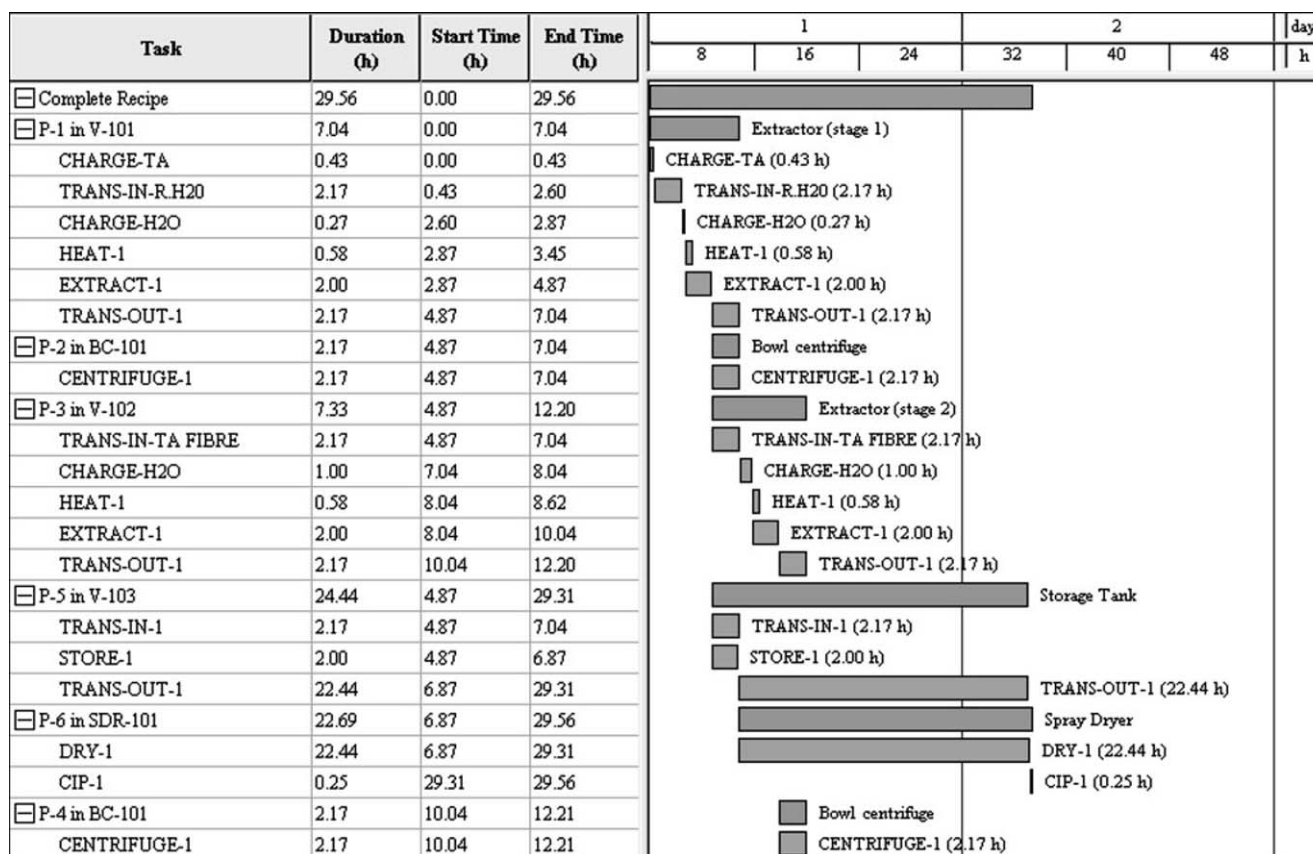

Figure 3. Operations Gantt Chart of base case simulation.

Table 2. Annual operating cost break down of base case simulation.

Cost item	USD/year	% contribution
Raw material	84 721	20.18
Labour-dependant	287 652	68.50
Laboratory/QC/QA	43 148	10.28
Utilities	1931	0.46
Waste treatment/disposal	2450	0.58
Total	419 902	100.00

debottlenecking schemes were developed based on the base case simulation. These schemes were analysed to evaluate their viability to increase the plant annual production. Economic evaluation was also performed to evaluate all debottlenecking schemes to identify the most economically attractive option.

ALTERNATIVE DEBOTTLENECKING SCHEMES

In Scheme 1 (Figure 5), a new spray drying procedure (P-8/SDR-102) was added in parallel with the existing spray dryer (P-7/SDR-101) to reduce the process time for spray drying operation by half. The process time of spray drying operation was reduced significantly from 22.11 h to 11.05 h while other equipment and scheduling setup remained unchanged. The losses of Tongkat Ali extract in both spray drying procedures were assumed to remain at 1%.

Scheme 2 adds a new double effect forward feed evaporator (P-6/EV-101) to concentrate the water extract prior to the spray dryer (Figure 6). Due to the reduction of volume in the Tongkat Ali water extract, the process time for the spray drying operation is assumed to reduce by half, i.e., from 22.11 h to 11.05 h. Operating conditions for all other unit procedures remain unchanged.

Figure 7 shows the simulation flowsheet of Scheme 3, which combines the strategies in the previous two schemes. Extract water from P-5/V-103 is transferred to the newly added double effect forward feed evaporator (P-6/EV-101) to be concentrated before it is sent to the two parallel spray dryers, P-8/SDR-101 and P-9/SDR-102 (newly added). The process time of spray drying operation was reduced significantly from 22.11 h to 5.17 h.

Table 3 shows the process throughput and economics summary of the three debottlenecking schemes as compared to the base case simulation model. All debottlenecking schemes demonstrate significant improvement on the annual production. This is mainly due to the reduction of minimum cycle time associated with spray drying procedures. Note that Scheme 2 and Scheme 3 exhibit lower value of overall product yield due to additional losses in the evaporator (P-6/EV-101). Among all schemes, Scheme 3 has the highest annual production and hence identified as the debottlenecking strategy.

However economic analysis of the proposed schemes reveals that these three schemes are still economically infeasible as the ROI values are still well below the desired 30% although the annual throughput has been increased.

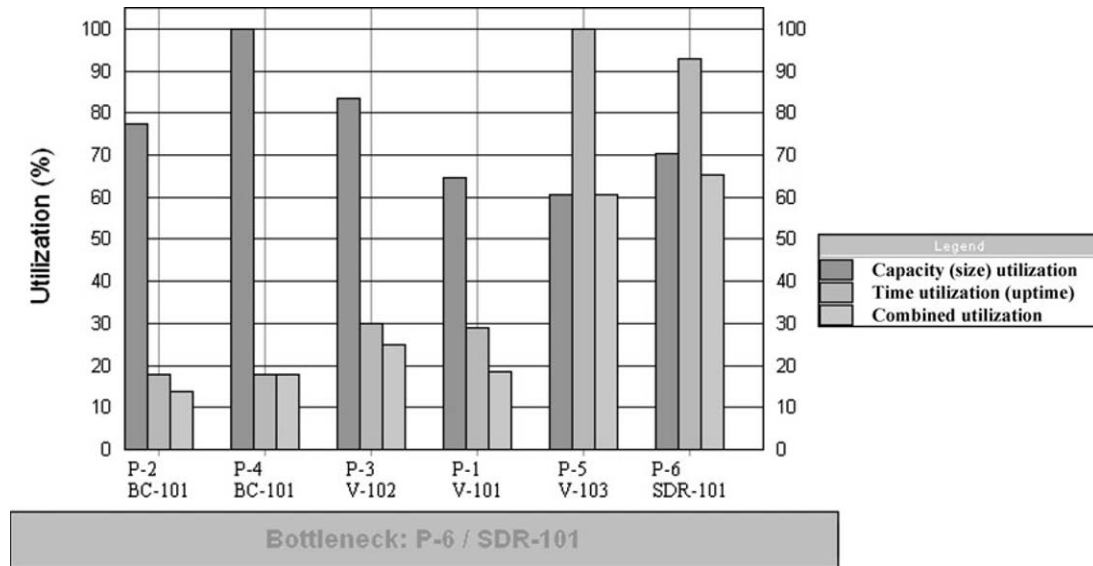

Figure 4. Throughput Analysis Chart for base case simulation.

All proposed schemes have seen an increase in capital and operating costs due to addition of new equipments. As shown in Table 3, the operating cost for all the debottlenecking schemes are higher than the total revenues. This leads to the low ROI values and therefore a payback period for all schemes is unachievable. The main reason for this defect is the low revenue of the final product. Therefore, in the final scheme proposed, Scheme 4, alternatives to produce a value-added product are implemented.

Attention is given on efforts to reduce process operating cost and to add value to the final product.

Economic Optimization Scheme

The first effort in Scheme 4 (Figure 8) is to reduce the raw material cost of the process by adding a new grinder (P-1/GR10) in the Extraction section. Raw material in the base case simulation is taken as the ground Tongkat

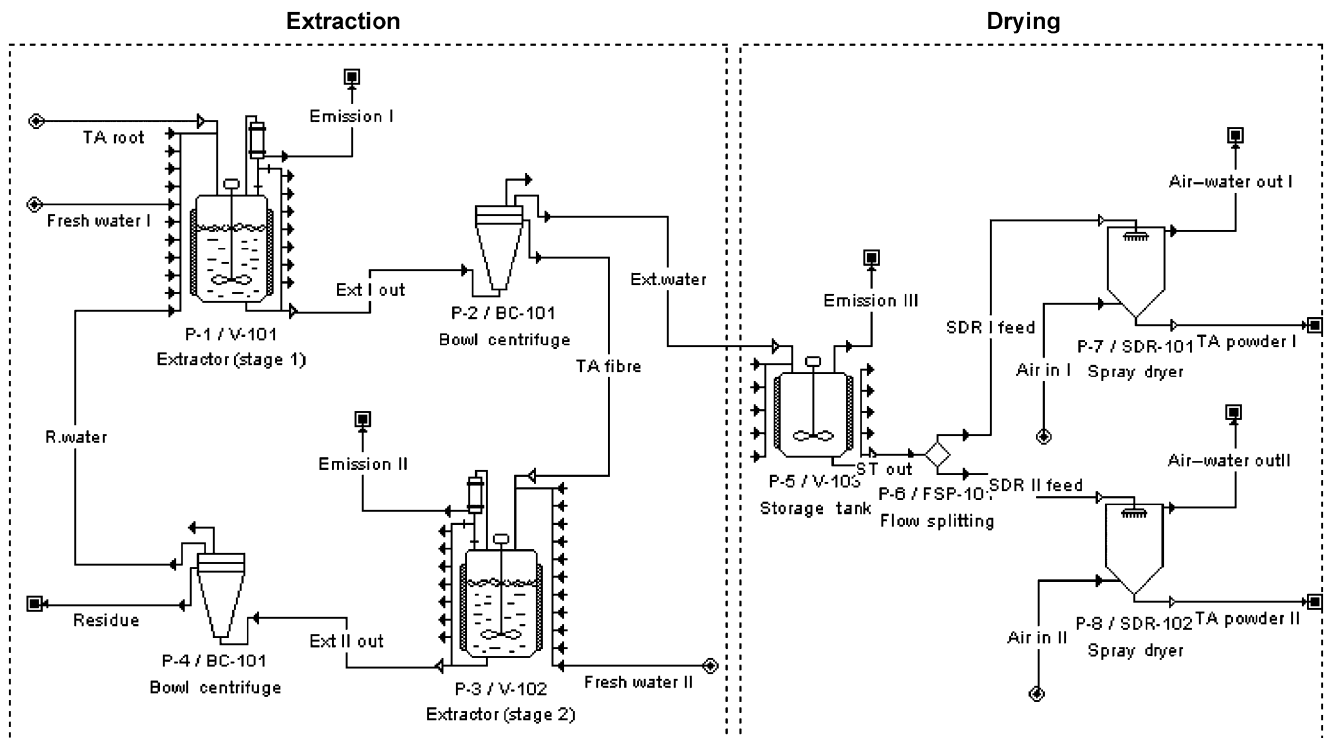

Figure 5. Simulation flowsheet of debottlenecking Scheme 1.

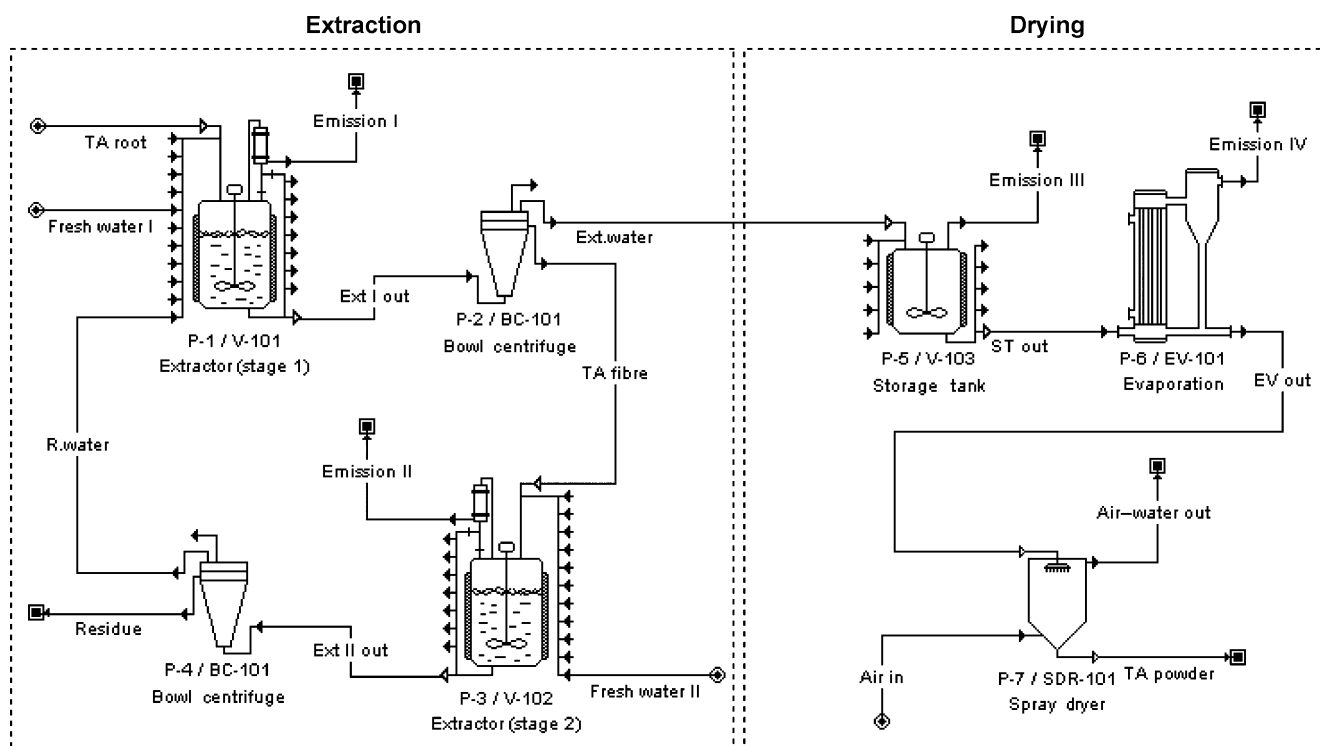

Figure 6. Simulation flowsheet of debottlenecking Scheme 2.

Ali wood chips with a cost of \$6.55/kg. With the addition of a grinder, the raw material can be substituted with fresh Tongkat Ali roots which cost \$3.20/kg, approximately half of the original cost.

Effort is next made to improve the process economics by producing a value-added final product. In all previous proposed schemes, the final product of Tongkat Ali extract powder is sold at a price of \$660/kg. An alternative to

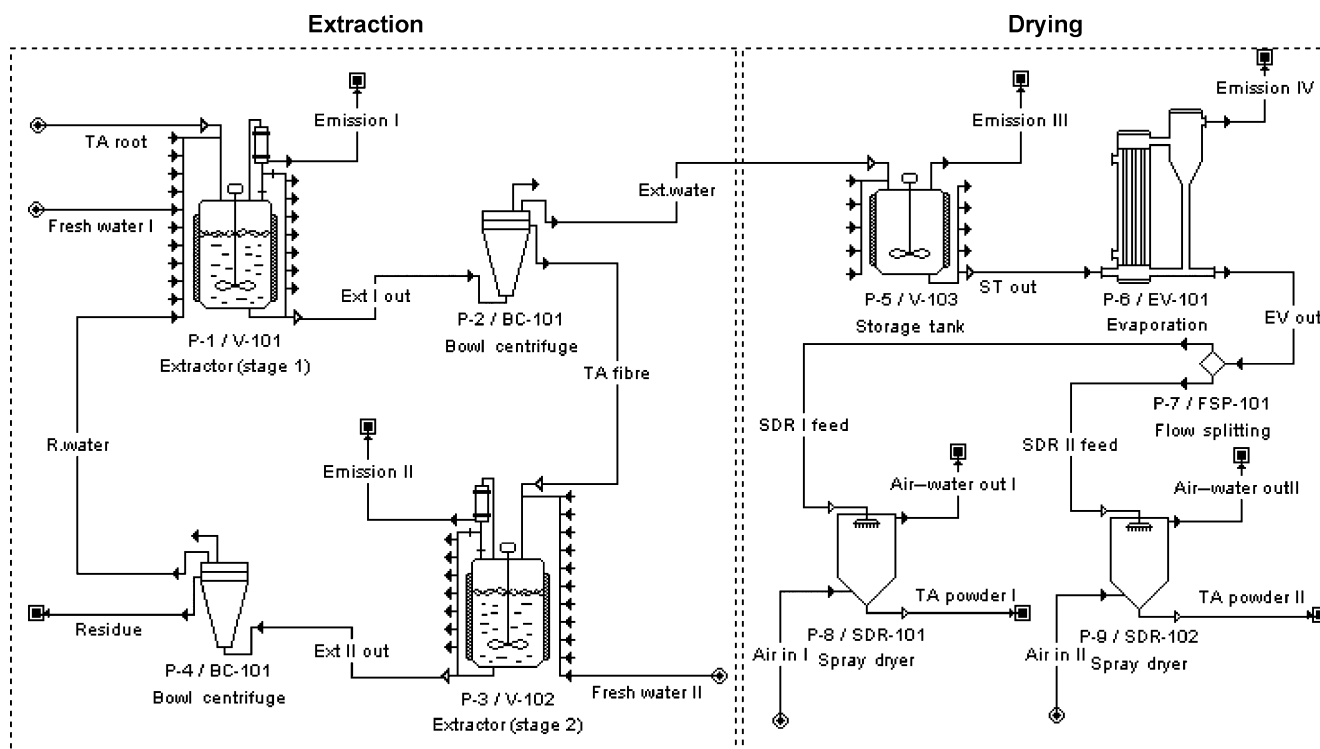

Figure 7. Simulation flowsheet of debottlenecking Scheme 3.

Table 3. Throughput and economic analysis results (2004 cost).

Process parameters	Base case	Scheme 1	Scheme 2	Scheme 3	Scheme 4
Throughput					
Overall product yield (%)	3.02	3.02	3.00	3.00	3.00
Batch production (kg/batch)	1.21	1.21	1.20	1.20	1.20
Minimum cycle time (h)	24.44	13.39	13.39	8.04	8.32
Plant batch time (h)	29.56	18.50	18.50	13.16	24.25
Number of batches per year	323	591	591	984	950
Annual production (kg y ⁻¹)	390.73	714.93	707.78	1178.44	1137.72
Economics					
Capital cost (\$)	2 982 306	4 708 959	3 536 058	5 268 828	5 910 770
Operating cost (\$/y)	419 901	627 088	662 102	935 159	883 852
Total revenues (\$/y)	257 883	471 854	467 136	777 769	6 321 297
Gross margin (%)	-62.83	-32.90	-41.74	-20.24	86.02
Return on investment, ROI (%)	5.43	3.30	5.51	2.99	55.20

produce a higher value-added product is the Tongkat Ali extract capsules which are sold at a price of \$26 per bottle of 60 capsules, which is equivalent to \$8700/kg of Tongkat Ali extract. To produce Tongkat Ali extract capsules, new equipment are needed in the Packing section. As shown in Figure 8, the newly added equipment include the procedures of capsule mixture preparation (P-12/MX-102),

capsuling (P-13/TB-101), bottling (P-14/BX-101) and boxing (P-15/BX-102).

The Tongkat Ali extract powder from the spray dryers is mixed with the filler of Maltodextrin, an easily digestible carbohydrate made from natural corn starch (user-defined component, purchase cost: \$1.50/kg) in procedure P-12/MX-102 at a ratio of 1 kg extract:8 kg Maltodextrin. The

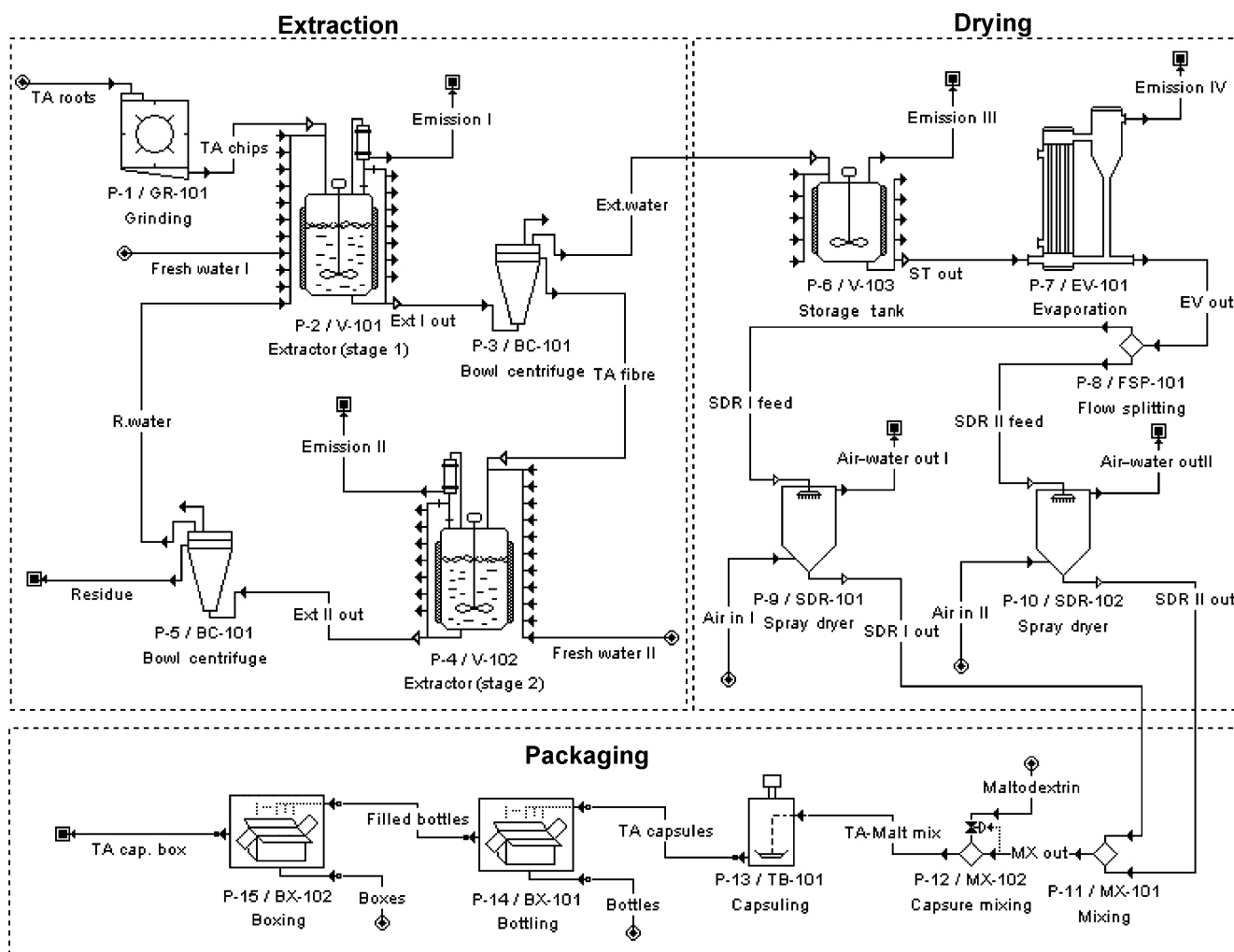

Figure 8. Simulation flowsheet of Scheme 4.

extract-Maltodextrin mixture is fed into a capsuling machine (P-13/TB-101) where the mixture is capsuled at a rate of 50 capsules min^{-1} containing 450 mg extract each. Once the capsuling operation begins in P-13, the capsules produced are fed into bottling machine (P-14/BX-101) where they are filled in plastic bottles (purchase price of \$0.10/bottle) at a rate of 60 capsules/bottle. When this operation is completed, the filled bottles are sent to the boxing operation (P-15/BX-102) where the bottles are packed in boxes (purchase price of \$0.13/box) with each box containing 12 bottles of Tongkat Ali extract capsules.

The final column of Table 3 shows that the process throughput of Scheme 4 has decreased due to the decrease in number of batches per year. This is mainly due to the installation of packaging equipment that results in longer minimum cycle time (the time bottleneck is now shifted to the bottling procedure P-14 in the Packaging section). The scheduling summary for Scheme 4 can be shown in Operation Gantt Chart (Figure 9).

The final product of Scheme 4 is no longer Tongkat Ali extract powder but extract capsules in a bottle packed in boxes. The total capital and operating cost has increased in Scheme 4 due to the installation of new grinding and packaging equipment as shown in Table 3. However this increase is justified by a drastic increase in the process revenues. This fulfils the objective to increase the total revenues with higher margin. As a result of the increase in revenues the gross margin and ROI have improved significantly. In the previous schemes calculations show that the capital investment was not recoverable since the operating cost exceeded the total revenues. If this scheme is implemented the capital investment can be recovered in 1.82 years with a ROI of 55%. Table 4 shows the main specifications and purchase cost of equipment utilised in Scheme 4, excerpted from the software SuperPro Designer[®]. Note that the purchase cost of these equipment is based on the local quoted rate. Also, the unlisted equipment (e.g., pumps, valves, and so on) cost is assumed to be 20% of the major equipment cost.

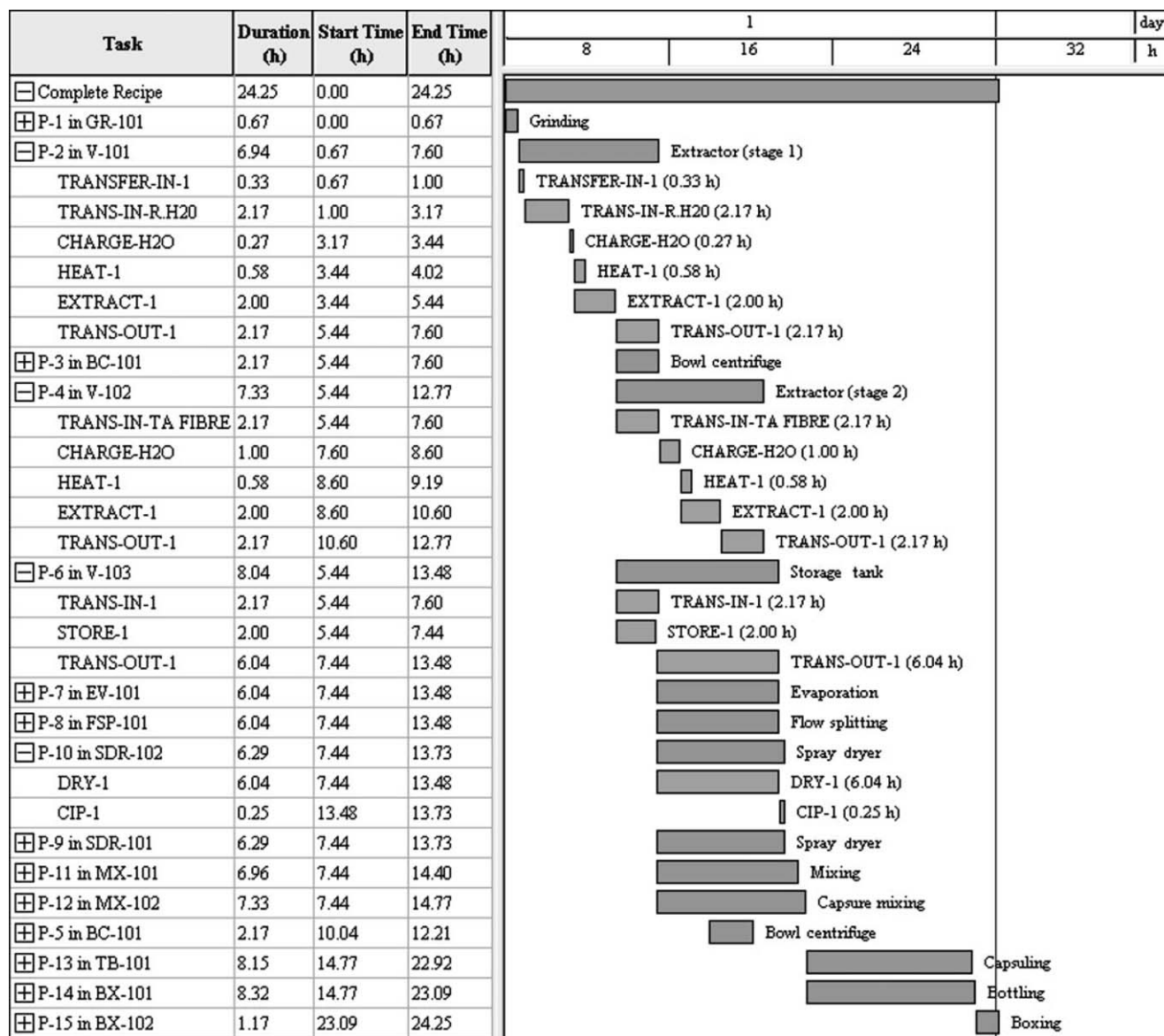

Figure 9. Operations Gantt Chart of Scheme 4.

Table 4. Equipment specifications and purchase cost for Scheme 4 (2004 cost).

Tag ID	Description	Specification	Purchase cost (\$)
GR-101	Grinder	Rated throughput = 80.00 kg h ⁻¹	10 000
V-101	Extraction vessel	Volume = 500.00 L Diameter = 0.63 m	21 000
V-102	Extraction vessel	Volume = 500.00 L Diameter = 0.63 m	21 000
V-103	Storage tank	Volume = 300.00 Diameter = 0.50 m	3000
BC-101	Bowl centrifuge	Sigma factor = 15 833.70 m ²	98 000
EV-101	Forward feed evaporator	Number of effects = 2 Area per effect = 0.03 m ²	65 000
SDR-101	Spray dryer	Diameter = 1.35 m Height = 1.75 m	209 000
SDR-102	Spray dryer	Diameter = 1.35 m Height = 1.75 m	209 000
MX-102	Capsule mixer	Rated throughput = 10.00 kg h ⁻¹	10 000
TB-101	Capsuling machine	Rated throughput = 50.00 parts/min	39 000
BX-101	Bottling machine	Rated throughput = 2.00 parts/min	10 000
BX-102	Boxing machine	Rated throughput = 1.00 parts/min	10 000
	Cost of unlisted equipment		177 000
	Total equipment purchase cost		883 000

CONCLUSION

Tongkat Ali extract production is modelled and optimized in this work based on an existing pilot scale manufacturing setup. The base case process is analysed and the spray drying section is identified as the overall process bottleneck. Three debottlenecking schemes are proposed and analysed through simulation. The debottlenecking scheme with the highest throughput that fulfils the customers' need is further analysed to assess its economic performance. Due to the unattractive economic performance a new grinder and packaging section were proposed to add value to the final product. The modification yields an annual revenue of \$6.3M with a gross margin of 86%, a return on investment of 55% and a payback period of less than 2 years.

REFERENCES

- Adenan, M.I., 2003, Malaysian herbs and herbal products, in a two and half day course of herbal and phytochemical processing, CEPP short course notes (Chemical Engineering Pilot Plant, Universiti Teknologi Malaysia, Malaysia).
- Aziz, R.A., Sarmidi, M.R., Kumaresan, S., Taher, Z.M. and Foo, D.C.Y., 2003, Phytochemical processing: the next emerging field in chemical engineering—aspects and opportunities, *Jurnal Kejuruteraan Kimia Malaysia*, 3: 45–60.
- Aziz, R.A., Sarmidi, M.R., Kumaresan, S. and Foo, D.C.Y., 2005, Engineering aspects of herbal and phytochemical processing: a Malaysian perspective, *Bulletin of Institution of Engineers Malaysia*, December: 10–19.
- Ernst, S., Garro, O.A., Winkler, S., Venkataraman, G., Langer, R., Cooney, C.L. and Sasisekharan, R., 1997, Process simulation for recombinant protein production: Cost estimation and sensitivity analysis for Heparinase I expressed in *Escherichia coli*, *Biotechnology and Bioengineering*, 53(6): 575–582.
- Evangelista, R.L., Kusnadi, A.R., Howard, J.A. and Nikolov, Z.L., 1998, Process and economic evaluation of the extraction and purification of recombinant β -Glucuronidase from transgenic corn, *Biotechnology Progress*, 14: 607–614.
- Intelligen, Inc., 2005, *SuperPro Designer® User's Guide* (Intelligen, Inc., Scotch Plains, New Jersey, USA).
- Ismail, Z., Ismail, N. and Lassa, J., 1999, *Malaysian Herbal Monograph* (Malaysian Monograph Committee, Kuala Lumpur).
- Kaur, I., Kumaresan, S. and Sarmidi, M.R., 2003, A study into the effect of laboratory scale processing parameters and scale up on *Eurycoma longifolia* water extract yield, *Proceedings of the 17th Symposium of Malaysian Chemical Engineers*, 29–30 December 2003, Penang, 294–299.
- Koulouris, A., Calandranis, J. and Petrides, D., 2000, Throughput analysis and debottlenecking of integrated batch chemical processes, *Comput Chem Eng*, 24: 1387–1394.
- Kuo, P.C., Shi, L.S., Damu, A.G., Su, C.R., Huang, C.H., Ke, C.H., Wu, J.B., Lin, A.J., Bastow, K.F., Lee, K.H. and Wu, T.S., 2003, Cytotoxic and antimalarial beta-carboline alkaloids from the roots of *Eurycoma longifolia*, *Journal of Natural Products*, 66(10): 1324–1327.
- Petrides, D.M., 1994, BioPro Designer: an advanced computing environment for modeling and design of integrated biochemical processes, *Comput Chem Eng*, 18: S621–S625.
- Petrides, D., Sapidou, E. and Calandranis, J., 1995, Computer-aided process analysis and economic evaluation for biosynthetic human insulin production—a case study, *Biotechnology and Bioengineering*, 48: 529–541.
- Petrides, D., Kououris, A. and Siletti, C., 2002, Throughput analysis and debottlenecking of biomanufacturing facilities: a job for process simulators, *BioPharm*, August: 2–7.
- Rouf, S.A., Douglas, P.L., Moo-Yoong, M. and Scharer, J.M., 2001, Computer simulation for large scale bioprocess design, *Biochemical Engineering Journal*, 8: 229–234.
- Shanklin, T., Roper, K., Yegneswaran, P.K. and Marten, M.R., 2001, Selection of bioprocess simulation software for industrial applications, *Biotechnology and Bioengineering*, 72(4): 483–489.
- Westerberg, A.W., Hutchison, H.P., Motard, R.L. and Winter, P., 1979, *Process Flowsheeting* (Cambridge University Press, Cambridge, UK).

ACKNOWLEDGEMENTS

The authors would like to thank Mr Norman Shah Md. Nor, the Technical Assistant of CEPP who provided necessary information for the case study of Tongkat Ali water extract production. The authors would also like to thank Dr Alexandros Koulouris, the Managing Director of Intelligen Europe, for his constructive feedback with this project. The financial support of Universiti Malaysia Sabah (UMS) through Academic Staff Training Scheme for the corresponding author is gratefully acknowledged.

The manuscript was received 5 January 2006 and accepted for publication 1 March 2006.