

Model Following Control with Discrete Time SMC for Time-Delayed Bilateral Control Systems

Cenk Oguz Saglam, Eray A. Baran, Ahmet O. Nergiz and Asif Sabanovic

*Faculty of Engineering and Natural Sciences
Sabanci University, Istanbul, Turkey*

{saglam, eraybaran, ahmetn, asif}@sabanciuniv.edu

Abstract—This paper proposes a new algorithm based on model following control to recover the uncompensated slave disturbance on time delayed motion control systems having contact with environment. In the previous works, a modified Communication Disturbance Observer (CDOB) was shown to be successful in ensuring position tracking in free motion under varying time delay [11], [12]. However, experiments show that due to the imperfections in slave plant Disturbance Observer (DOB) when there is rapid change of external force on the slave side, as in the case of environment contact, position tracking is degraded. This paper first analyzes the effect of environment contact for motion control systems with disturbance observers. Following this analysis, a model following controller scheme is proposed to restore the ideal motion on the slave system. A virtual plant is introduced which accepts the current from the master side and determines what the position output would be if there was no environment. Based on the error between actual system and model system, a discrete time sliding mode controller is designed which enforces the real slave system to track the virtual slave output. In other words, convergence of slave position to the master position is achieved even though there is contact with environment. Experimental verification of the proposed control scheme also shows the improvement in slave position tracking under contact forces.

Keywords—Bilateral control, teleoperation, motion control, time delay, disturbance observer, sliding mode control

I. INTRODUCTION

Bilateral control systems take place among the most popular branches of control research. Recently, bilateral teleoperation systems have been paid considerable attention and are expected to be one of the emerging points of modern developments in robotics science. The potential applications of the teleoperation systems include network robotics, tele-surgery, space and seabed telemanipulation, micro-nano parts handling, inspection and assembly.

As the name dictates, an ideal bilateral control system has two major objectives: tracking of master system position reference by the slave system and force feedback to the master system from the slave system. Although position and force synchronization between the master and slave devices can be achieved in laboratory environment,

network delays create very serious problems in implementing bilateral control over far distant regions. Time delay has the potential to destabilize an otherwise stable control system.

In the literature, many methods have been proposed that contribute to the stability and tracking performance in time delayed control systems. Among those, methods based on passivity theory [1], [2], wave variables [3], [4], optimal [5] and predictive [6] control schemes can be counted. A detailed historical review of time delayed control can be found in [7].

Regarding the time delayed bilateral control, recently proposed Communication Disturbance Observer (CDOB) seems to bring a conclusion to stability problem originated from a variable delay of any magnitude [8], [9]. Disregarding the model of the time delay, this method approaches the problem by lumping all undesired effects of time delay to a concept called network disturbance. This network disturbance is then estimated via DOB and compensated accordingly. In [11] and [12], it is also shown that with the addition of PD convergence terms with equal gains to both observer and slave plant, position tracking of CDOB structure can be assured even though the initial positions and velocities of master and slave systems are different. However, the CDOB based structures developed in [8], [9], [11] and [12] assume that there is perfect disturbance cancelation on the slave plant, which is a weak assumption in general. When there are rapid changes in the external forces, such as rapid contact with environment, position tracking of slave system deteriorates basically due to the limitations of DOB used in the slave plant. Correspondingly, the force feedback to the master side is also affected and overall system performance is degenerated.

In this paper, a model following controller with discrete time SMC structure is proposed to recover the uncompensated disturbance of the remote plant on time delayed motion control systems having contact with environment. The organization of the paper is as follows. In section II, first a background information is given on robust motion control with DOB. Following that the general structure of a system with time delay is briefly investigated and the solution achieved with CDOB is summarized. In section III, problem created by rapid contact forces is formu-

lated. In section IV, a model following control structure is proposed and a discrete time sliding mode controller is constructed to compensate the non-idealities in position tracking when there is environment contact. Section V presents the experiment results. And finally, in section VI, concluding remarks are given.

II. BACKGROUND

A. System Definition

In the following analysis, demonstration of the controller design will be made on a single DOF motion control system for which the plant dynamics can be given as

$$a_n \ddot{q}(t) = \tau(t) - \tau_{dis}(t) \quad (1)$$

where, a_n and $\tau_{dis}(t)$ represent the nominal plant inertia and disturbance torque acting to the plant respectively. The input torque to the system can be modeled as a scalar multiple of the input current and nominal torque constant (i.e. $\tau(t) = K_n i_c(t)$). Substituting into (1) gives the following

$$a_n \ddot{q}(t) = K_n i_c(t) - \tau_{dis}(t) \quad (2)$$

In equation (2), it is assumed that the term τ_{dis} lumps all undesired effects, including the viscous friction ($b(q, \dot{q})$), deviations from the nominal values for torque constant (ΔK_n) and inertia (Δa_n), gravitation ($g(q)$) and all other non-modeled external torques (τ_{ext}). This way the model of disturbance torque can be given as

$$\tau_{dis} = \Delta a_n \ddot{q} + \Delta K_n i_c + b(q, \dot{q}) \dot{q} + g(q) + \tau_{ext} \quad (3)$$

B. Disturbance Observer and Acceleration Control

For the dynamic system given in (2), removing the disturbance torque is of crucial importance for the applicability of acceleration control. To estimate and cancel the disturbance acting to the system, a disturbance observer (DOB) can be realized [13]. The internal structure of disturbance observer includes a low pass filter. Having a high filter gain, disturbance observer can be designed to cancel the disturbance torque as quickly as possible. The estimated disturbance can be obtained from the velocity response \dot{q} and current input i_c of the system and be fed back to the plant. The velocity response is calculated from the position data using a velocity observer. However, although in many applications disturbance observer can effectively increase the robustness of a system, due to the low pass filter used in the structure, the disturbance might not always be fully compensated, which in turn leads to imperfections in estimation. Having this in mind, the motion control system given in (2), with the addition of disturbance observer, can be re-formulated as follows

$$a_n \ddot{q}(t) = K_n i_c(t) - \delta \tau_{dis}(t) \quad (4)$$

where, $\delta \tau_{dis}(t) = \tau_{dis}(t) - \hat{\tau}_{dis}(t)$ stands for the disturbance estimation error. When there is perfect disturbance cancelation the plant behaves like a double integrator

system. But because of the imperfection on DOB output, the estimation error is also double integrated. So, without additional control loop, the velocity and position responses can diverge from the corresponding references, which can be modeled as

$$\begin{aligned} \dot{q}^{res}(t) &= \dot{q}^{ref}(t) + \frac{1}{a_n} \int_0^t \delta \tau(\zeta) d\zeta \\ q^{res}(t) &= q^{ref}(t) + \frac{1}{a_n} \int_0^t \int_0^\zeta \delta \tau(\zeta) d\zeta d\xi \end{aligned} \quad (5)$$

where, the superscripts *ref* and *res* represent the reference and response of the corresponding variable respectively. The structure of disturbance observer is given in Fig. 1.

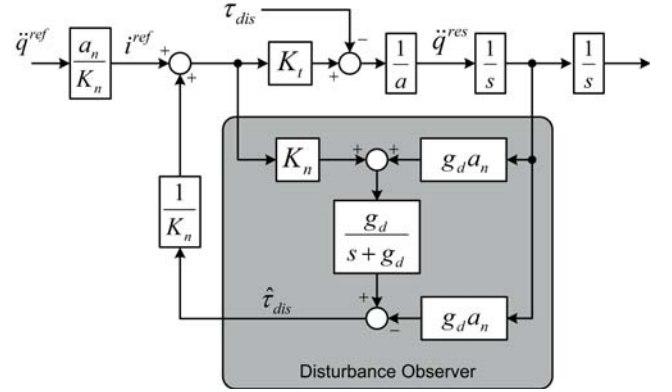

Fig. 1. Structure of the Disturbance Observer

C. Overview of Time Delayed Effect and CDOB

A time delayed motion control system is one that does not allow real time signal transmission through either control or measurement or (in general) both channels. As shown in Fig. 2, when there are delays in the signal transmission channels, controller cannot obtain the information of states on time and cannot generate the necessary control input. Under these conditions, solution can be obtained by estimating the future states of the remote plant via an observer/predictor structure.

One such predictive scheme is Communication Disturbance Observer (CDOB). In that scheme, the effect created by the time delay is considered as a disturbance in acceleration dimension which can be given by

$$\tau_{dis}^{nw}(t) = K_n i_c(t) - a_n \ddot{q}_s(t - D_m) \quad (6)$$

where $\tau_{dis}^{nw}(t)$ represents the network disturbance, D_m stands for the delay in the measurement channel and q_s represents the slave position. Once the problem is put into this format, estimation of network disturbance can be made with a DOB which is termed as the Communication Disturbance Observer due to obvious reasons. Just like the conventional disturbance observer structure, the estimation of this network disturbance can be made using delayed slave plant velocity and a low pass filter. The estimated network disturbance stand for the torque that is supposed

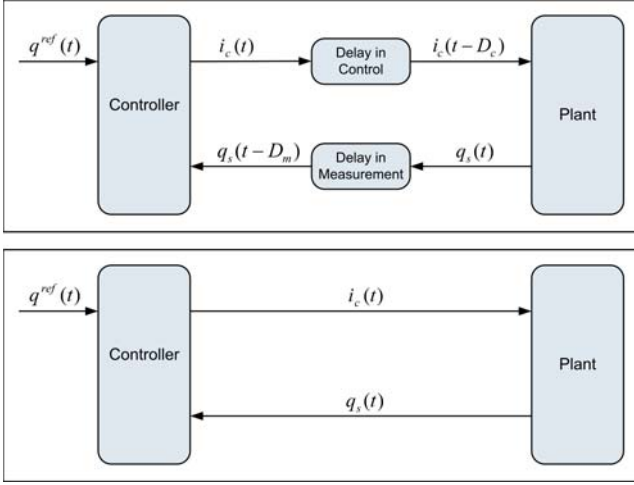

Fig. 2. Structure of system with and without delay

to act on the slave plant during measurement delay. Since the slave plant is enforced to behave nominal with DOB, the estimated network disturbance can be passed through the nominal inertia of slave plant and be integrated to give the velocity difference that is supposed to exist during the delay time. In mathematical terms, this can be expressed as

$$\Delta \dot{q}_s(t) = \frac{1}{a_n} \int \tau_{dis}^{nw}(\varphi) d\varphi \quad (7)$$

Addition of this velocity difference to the delayed slave velocity gives the estimated velocity of the slave plant as shown below

$$\hat{q}_s(t) = \dot{q}_s(t - D_m) + \Delta \dot{q}_s(t) \quad (8)$$

The depiction of CDOB structure is given in Fig. 3 below. Further information about CDOB can be found in [8] and [9], whereas a stability analysis is given in [12].

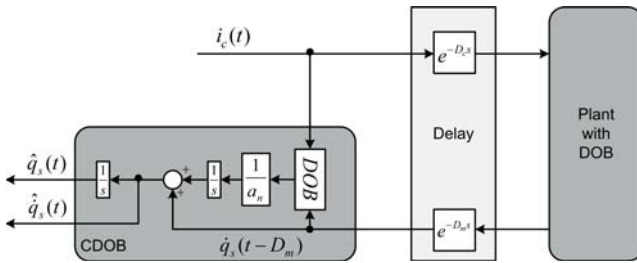

Fig. 3. Structure of CDOB

III. PROBLEM DEFINITION

For the time delayed system given above, an observer can only be constructed based on nominal slave system behavior. So, in order to use predictive schemes, one has to make sure that the remote plant has nominal behavior (i.e. acting as a double integrator). The remote plant acts as a nominal plant when all the disturbances are rejected. In order to provide disturbance rejection, usually the slave plant is supplied with a disturbance observer.

Recalling from equation (2), DOB alone is not enough to fully compensate the disturbance in the system. Switching to frequency domain, the disturbance compensation error given in (2) can more explicitly be written as

$$\begin{aligned} \delta \tau_{dis}(s) &= \tau_{dis}(s) - \tau_{dis}(s) \left(\frac{g_d}{s + g_d} \right) \\ \delta \tau_{dis}(s) &= \tau_{dis}(s) s \frac{1}{g_d} \left(\frac{g_d}{s + g_d} \right) \end{aligned} \quad (9)$$

As obvious from (9), the remaining disturbance estimation error in classical DOB scheme include the filtered and scaled derivative of the disturbance acting on the system. Since it is impossible to have an infinite filter gain g_d , there is always an error proportional to the derivative of the total disturbance. Because of this, in cases where disturbance torque changes very fast and with a uniform sign (i.e. either increase or decrease), the total error in disturbance rejection becomes effective. The environment contact forces, unlike the other disturbances acting on the plant, has such a structure.

The remaining disturbance creates a difference between the acceleration reference and response on the slave side. Recalling from (5), the difference in the acceleration goes through a double integrator which results in a divergence of position and velocity responses from their corresponding reference values. An experimental verification of this phenomena is given in Fig. 4 in which the master reference is sent to the slave plant after a time delay and both ideal reference and the actual responses are plotted. As it is obvious from the figure, the tracking error is proportional to the speed of motion (i.e. rate of change of disturbance).

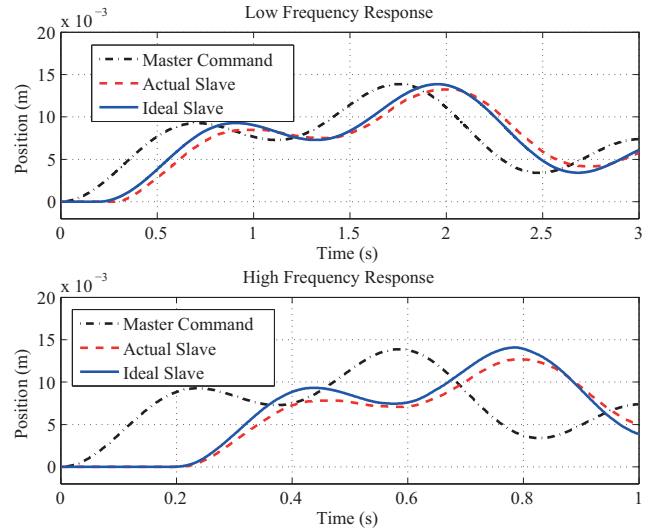

Fig. 4. Slave system position responses for motion under environment contact

In order to analyze the effect of this divergence on the

master side, one can make the following definitions:

$$\begin{aligned}\Delta\ddot{q}_s(t) &= \ddot{q}_s^{ref}(t) - \ddot{q}_s^{res}(t) \\ \Delta\dot{q}_s(t-D_m) &= \dot{q}_s^{ref}(t-D_m) - \dot{q}_s^{res}(t-D_m)\end{aligned}\quad (10)$$

where, $\Delta\ddot{q}_s$ represent the difference between the slave system acceleration reference and its corresponding response. Recalling that the term $\tau_{dis}(t)$ in (2) is equal to zero for a nominal system and substituting the corresponding values to (6), the network disturbance can be given as

$$\tau_{dis}^{nw}(t) = a_n \ddot{q}_s^{ref}(t) - a_n \ddot{q}_s^{res}(t-D_m) \quad (11)$$

Using the identity given in (10), one can arrange (11) to get

$$\tau_{dis}^{nw}(t) = a_n \ddot{q}_s^{ref}(t) - a_n \ddot{q}_s^{ref}(t-D_m) + a_n \Delta\ddot{q}_s(t-D_m) \quad (12)$$

Now, by using equations (7) and (8), the estimated slave velocity on the master side can be obtained as

$$\begin{aligned}\hat{q}_s(t) &= \dot{q}_s^{res}(t-D_m) + \dot{q}_s^{ref}(t) - \dot{q}_s^{ref}(t-D_m) + \Delta\dot{q}_s(t-D_m) \\ \hat{q}_s(t) &= \dot{q}_s^{res}(t-D_m) + \dot{q}_s^{ref}(t) - \dot{q}_s^{res}(t-D_m) \\ \hat{q}_s(t) &= \dot{q}_s^{ref}(t)\end{aligned}\quad (13)$$

Equation (13) clearly shows that the observer/predictor structure of master side is blind to the divergence on the slave side. This is basically due to the intrinsic assumption of the observer that the slave system behaves nominal.

The incapability of CDOB to observe the divergence of slave position becomes even more important when force control is integrated to the system. So far, the solution for force control in time delayed systems depend on the estimation of remote environment parameters and reconstruction of a virtual environment on the master side [15]. When there is a mismatch between the reference slave position and its corresponding response, the estimation of environment parameters on the master side is also affected. So, the overall control loop performance degrades considerably.

IV. MODEL FOLLOWING CONTROLLER WITH DISCRETE TIME SMC

A. Controller Structure

For the problem described in the previous section, a model following control scheme is proposed. The structure of the controller is based on the use of a virtual slave plant model that is identical to the actual slave system except the fact that it does not include any environment model. In this structure, since the virtual model is fed with the same input to the slave plant and since it does not involve the effect of environment on total disturbance, it can generate the ideal trajectory for the slave plant motion. Once this ideal reference is generated, additional compensation can be inserted to the actual slave plant using the error between actual slave and virtual slave model. For the generation of additional compensation, a

discrete time sliding mode controller (SMC) is used. The block diagram of the model following controller is given in Fig. 5 below. The derivation of the controller is made in the following subsection

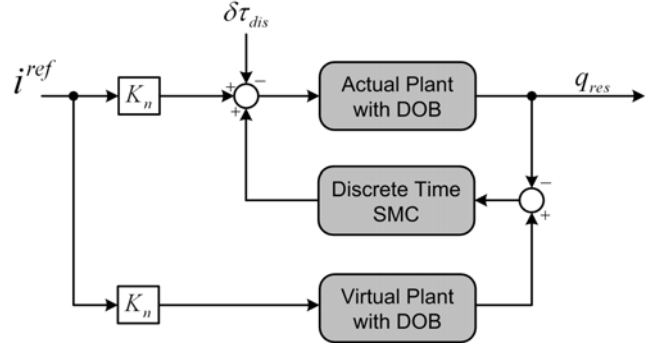

Fig. 5. Model following controller structure

B. Discrete Time SMC Controller Derivation

The error between virtual and actual plants can be represented in the following vector form:

$$\xi = \begin{bmatrix} \Delta x \\ \Delta \vartheta \end{bmatrix} \doteq \begin{bmatrix} x^{vir} - x^{act} \\ \vartheta^{vir} - \vartheta^{act} \end{bmatrix} \quad (14)$$

where, the superscripts "vir" and "act" represent the virtual and actual plant outputs respectively. For sliding mode design, one can pick the following manifold to enforce a zero rate of change for a general linear combination of the position and velocity errors;

$$\sigma = G\xi = \begin{bmatrix} \alpha & \beta \end{bmatrix} \begin{bmatrix} \Delta x \\ \Delta \vartheta \end{bmatrix} \quad (15)$$

with $G \in \mathbb{R}^{1 \times 2}$. For this system, in order to enforce finite time convergence, the following dynamics can be written on σ

$$\dot{\sigma} + \lambda\sigma + \mu \cdot \text{sign}(\sigma) = 0 \quad (16)$$

where λ is necessarily positive definite in order to satisfy the Lyapunov stability condition. From the definition of sliding mode, the derivative of the manifold can also be expressed in terms of the equivalent control as follows:

$$\dot{\sigma} = GB(u^{eq} - u) \quad (17)$$

Inserting (17) back to the imposed finite time converging dynamics (16), one can come up with the following equation:

$$GB(u^{eq} - u) + (\lambda\sigma + \mu \cdot \text{sign}(\sigma)) = 0 \quad (18)$$

Now, in light of equation (18) and keeping in mind that the implementation will be made on a discrete time system, one can finally write down the following recursion for the controller:

$$u[k] = u[k-1] + (GB)^{-1}(\lambda\sigma + \mu \cdot \text{sign}(\sigma)) \quad (19)$$

For the system under scope, the matrices G and B can be given as:

$$G = \begin{bmatrix} \alpha & \beta \end{bmatrix}$$

$$B = \begin{bmatrix} 0 & \frac{K_n}{a_n} \end{bmatrix}^T$$

Substituting these matrices and σ from (15) back to equation (19), the recursion can be put to the following final form

$$u[k] = u[k-1] + \Theta \quad (20)$$

where,

$$\Theta = \frac{a_n}{K_n} \left\{ \frac{\lambda}{\beta} (\alpha \Delta x + \beta \Delta \vartheta) + \frac{\mu}{\beta} (\text{sign}(\alpha \Delta x + \beta \Delta \vartheta)) \right\}$$

Equation (20) enforces condition to have zero position and velocity tracking error which means that the actual plant output is enforced to follow the virtual plant output (i.e. ideal slave motion).

V. EXPERIMENTS

A. Experimental Setup

Illustration of the closed loop system behavior is verified on an experimental setup consisting of linear motors. Two Hitachi-ADA series linear AC motors and drivers are used as the experimental platform. The linear motors had Renishaw RGH41 type incremental encoders with $1\mu\text{m}$ resolution. So the error bound to define the overall system performance is $1\mu\text{m}$. MATLAB-Simulink environment along with Matlab-Executable (MEX) subroutines were used as the implementation software and real time processing was enabled by a D-Space DS1103 card. The experiments are conducted with time delay in both measurement and control channels. In order to approximate the most realistic scenario, the structure of the time delay is adjusted to have variation within a certain range over a constant value. A sampling frequency of 1KHz was used for the overall control loop. A picture of the experimental setup is provided in Fig. 6.



Fig. 6. Experimental Setup

B. Experiment Results

The developed model following controller scheme is tested on the experiments. In order to put more emphasis on position error, the error cost was selected as $\begin{bmatrix} \alpha & \beta \end{bmatrix} = \begin{bmatrix} 5 & 1 \end{bmatrix}$. Moreover, in order to reduce the chattering effect, a very small coefficient was selected for the signum function (i.e. $\mu = 0.001$). And finally, the exponential convergence rate was selected to be $\lambda = 10$.

During implementation, two different computer generated reference trajectories were imposed on the system. The first trajectory included a combination of sinusoidal waves with different amplitudes and frequencies while the second reference contained a triangular wave form. After the addition of the proposed controller, it is observed that the slave system can exhibit perfect tracking of master reference after the control channel delay. The results of the experiments are depicted in Fig. 7 and Fig. 9 for the sinusoidal and triangular references respectively. The tracking errors corresponding to uncompensated and compensated systems are shown in Fig. 8 for sinusoidal trajectory and Fig. 10 for triangular trajectory respectively.

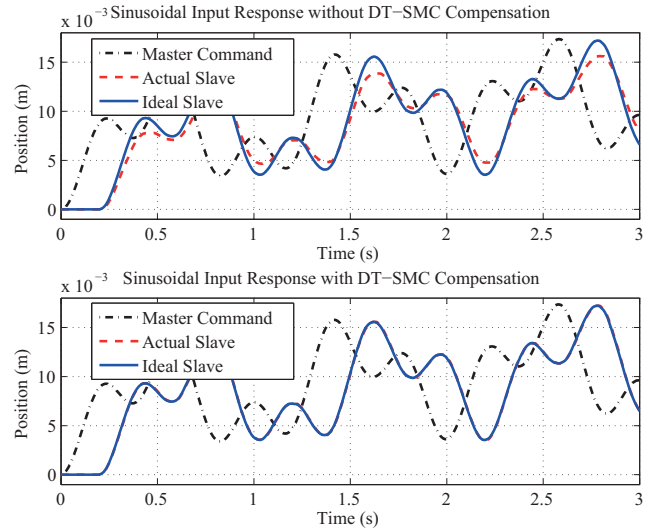

Fig. 7. Environment contact motion with sinusoidal input

VI. CONCLUSION AND FUTURE WORK

A. Conclusion

In this paper, a model following controller scheme is developed to provide additional disturbance compensation to the slave plant in time delayed control systems. In that sense, first the problem arising due to the DOB based structure is analyzed and it is shown that for rapid changes of external force like the environment contact forces, DOB is not able to fully compensate the disturbance. It is proven that the CDOB on the master side is blind to such uncompensated disturbances on the slave side. The developed controller is based on a virtual plant model in which the effect of environment is disregarded. Convergence of error between the actual and virtual model is achieved via a discrete time sliding mode controller. Experimental results

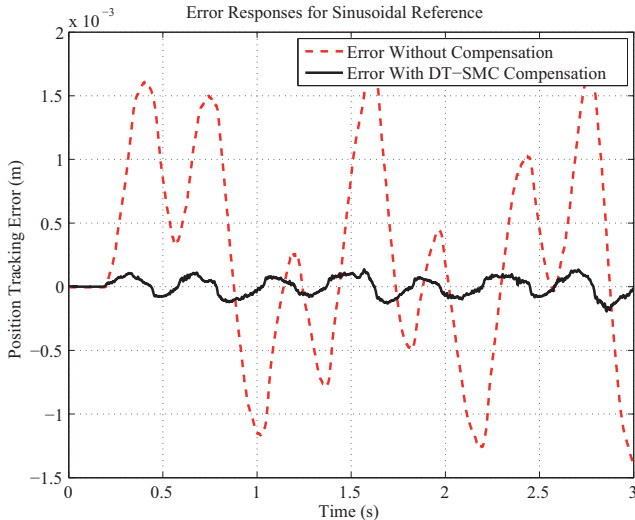

Fig. 8. Compensated and uncompensated tracking errors

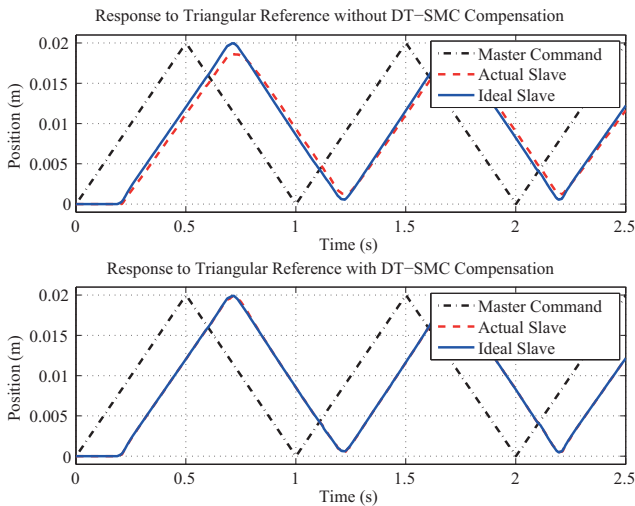

Fig. 9. Environment contact motion with triangular input

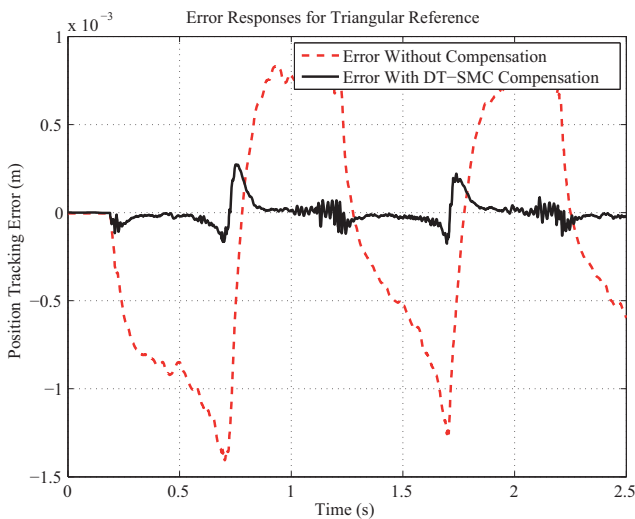

Fig. 10. Compensated and uncompensated tracking errors

confirmed the success of the proposed model following controller structure.

B. Future Work

Further research can be made about the force estimation of the slave plant on the master side. The errors between the virtual and actual slave system responses can be used as identifiers in a proper setting since they contain the information related to the slave environment. Combined with a good estimation structure on the master side, these identifiers might be used to reconstruct the slave environment or slave contact forces without delay.

VII. ACKNOWLEDGEMENTS

This work was supported partially by TUBITAK-Bideb and partially by TUBITAK project 108M520.

REFERENCES

- [1] R. J. Anderson and M. W. Spong, "Bilateral Control of Teleoperators with Time Delay", *IEEE Transactions on Automatic Control*, vol. 34, no. 5, pp 494-501, May 1989.
- [2] J. H. Ryu, D. S. Kwon, B. Hannaford, "Stable Teleoperation with Time Domain Passivity Control", *IEEE Transactions on Robotics and Automation*, vol. 20, no. 2, pp 365-373, April 2004.
- [3] G. Niemeyer and J. Slotine, "Stable Adaptive Teleoperation", *IEEE Journal of Ocean Engineering*, vol. 16, no. 1, pp 152-162, Jan. 1991.
- [4] G. Niemeyer, "Using Wave Variables in the Time Delayed Force Reflecting Teleoperation", *PhD Thesis, MIT, Cambridge, MA*, 1996.
- [5] G. M. H. Leung, B. A. Francis, J. Apkarian, "Bilateral Controller for Teleoperators with Time Delay via μ -Synthesis", *IEEE Transactions on Robotics and Automation*, vol. 11, no. 1, pp 105-116, 1995.
- [6] T. Slama, D. Aubry, R. Oboe, F. Kratz, "Robust Bilateral Generalized Predictive Control for Teleoperation Systems", *Mediterranean Conference on Control and Automation*, June 2007, pp 1-6
- [7] P. F. Hokayem and M. W. Spong, "Bilateral teleoperation: An historical survey", *Automatica*, vol. 42, no. 12, pp 2035-2057, September 2006.
- [8] K. Natori, "Time Delay Compensation for Motion Control Systems", *PhD Thesis, Keio University, Yokohama, Japan*, 2008.
- [9] K. Natori, R. Oboe, K. Ohnishi, "Analysis and Design of Time Delayed Control Systems with Communication Disturbance Observer", *IEEE International Symposium on Industrial Electronics*, Vigo, Spain, June 2007, pp 3132-3137
- [10] K. Natori, T. Tsuji, K. Ohnishi, "Time Delay Compensation by Communication Disturbance Observer in Bilateral Teleoperation Systems", *IEEE International Workshop on Advanced Motion Control*, Istanbul, Turkey, March 2006, pp 218-223
- [11] A. Sabanovic, K. Ohnishi, D. Yashiro, M. Acer, N. S. Behlilovic, "Control Systems with Network Delay", *International Conference on Electrical Drives and Power Electronics*, Dubrovnik, Croatia, October 2009
- [12] A. Sabanovic, K. Ohnishi, D. Yashiro, N. Sabanovic, Eray A. Baran, "Motion Control Systems with Network Delay", *Automatika*, vol. 51, no. 2, pp 119-126, 2010.
- [13] K. Ohnishi, M. Shibata, T. Murakami, "Motion Control for Advanced Mechatronics", *IEEE Transactions on Mechatronics*, vol. 1, no. 1, pp 56-67, 1996.
- [14] T. Murakami, F. Yu, K. Ohnishi, "Torque Sensorless Control in Multidegree-of-Freedom Manipulator", *IEEE Transactions on Industrial Electronics*, vol. 40, no. 2, pp 259-265, 1993.
- [15] K. Kitamura, D. Yashiro, K. Ohnishi, "Bilateral Control using Estimated Environmental Stiffness as the Master Position Gain", *The 35th Annual Conference of IEEE Industrial Electronics Society (IECON)*, Porto, Portugal, November 2009, pp 2981-2986