

15<sup>th</sup> International Power Electronics and Motion Control Conference, EPE-PEMC 2012 ECCE Europe, Novi Sad, Serbia

# A multi-purpose control and power electronic architecture for active magnetic actuators

A. Bonfitto<sup>1</sup>, G. Botto<sup>2</sup>, M. Chiaberge<sup>3</sup>, L.D. Suarez<sup>1</sup>, A. Tonoli<sup>4</sup>

<sup>1</sup>Mechatronics Laboratory - LIM, Politecnico di Torino, Torino, Italy, [lim@polito.it](mailto:lim@polito.it)

<sup>2</sup>Istituto Superiore Mario Boella, Torino, Italy, [botto@ismb.it](mailto:botto@ismb.it)

<sup>3</sup>Department of Electronics and Telecommunications, Politecnico di Torino, Torino, Italy, [marcello.chiaberge@polito.it](mailto:marcello.chiaberge@polito.it)

<sup>4</sup>Department. of Mechanical and Aerospace Engineering, Politecnico di Torino, Torino, Italy, [andrea.tonoli@polito.it](mailto:andrea.tonoli@polito.it)

**Abstract** — This paper shows the results related with the design and implementation of a multi-purpose electronic architecture used to drive magnetic actuators by means of a three-phase independent-legs module in place of the commonly used H-bridge modules. The typical application is the magnetic actuators drive used in active magnetic bearings. The architecture is composed of a control unit with a floating point Digital Signal Processor (DSP), a power board with six independent phase legs and a carrier board to interconnect them. When more than one module is required by the application, the communication between them is guaranteed by means of CAN bus interconnection.

The proposed system allows to drive two pairs of opposite electromagnets, such as those typically used to control active magnetic bearings. The study is motivated by the opportunity of reducing the amount of power and control electronic components resulting in a more straightforward, efficient and cost reduction design.

**Keywords** — Active magnetic actuators, DSP-based control, AMB.

## I. INTRODUCTION

Magnetic actuators found a great spread in many fields in the last decades with the related development of new driving and control technologies. This is due mostly to their versatility leading to the possibility of using them in different application areas. Indeed, they offer several technological advantages which allow to improve performance with respect to classical actuation strategies and allow to overcome many issues during the design phase and in working conditions.

Magnetic bearings establish themselves as one of the most demanding application of magnetic actuators. The promising aspects of this technology lead in recent times to a considerable research effort and nowadays is quite common to find magnetic actuators and bearings in areas like turbomachinery, vibrations isolation, kinetic energy storage, vacuum techniques, e.g. [1,2,3,4,5].

The main advantages lie in the absence of all fatigue and tribology issues due to mechanical contact, in the predictability of the behaviour, in the high temperature ranges and in the possibility to tune bearings stiffness and damping.

Magnetic bearings exploit magnetic fields which generate forces on ferromagnetic targets [6,7,8]. They are always inherently unstable systems and require the presence of a closed-loop control to counteract the negative stiffness generated by electromagnetic forces.

Current and/or voltage commands are generated sampling the displacement of the suspended object in order to produce the required force command. However, the amplitude and frequency ranges are limited by the voltage and current ratings of the power electronic circuits and the bearing winding inductances. If the current response is not fast enough the feedback loop becomes unstable which results in shaft touch-down.

Recent studies on magnetic bearings are focused mostly on two subsystems: the control algorithms and the power electronic architecture. The control aspects are treated in deep in literature. The high number of proposed strategies is the proof of the potential and versatility of this kind of solution [9,10]. In some applications the choice of the power amplifier stage is strictly related to the control technique such as in the case of self-sensing technique based on switching amplifiers [11,12,13,14].

The work described in this paper deals with switched mode amplifiers for magnetic bearings applications. Typically AMB applications include five couples of electromagnets, each controlling one rotor degree of freedom. Each electromagnet is driven by an H-bridge. The aim of the proposed architecture is to drive both electromagnets of an actuation axis by using a three-phase inverter instead of two H-bridges.

This configuration allows to reduce the costs increasing performance and overall efficiency of the system: moreover the proposed control system can be used also with three-phase AMB coil topology just adding a single active leg (one leg per coil plus one common leg).

## II. ELECTRONIC SYSTEM ARCHITECTURE

The electronic architecture, called Multi-Purpose Power Module (MPPM), is constituted of three modules:

- Control Card (a in Figure 1): based on a DSP, is dedicated to the digital control
- Carrier Board (b in Figure 1): interconnects the Control Card with the power stage
- Power Module (c in Figure 1.c): power module including six phase legs

The Control Card is based on a Texas Instruments floating point Digital Signal Processor (DSP); the card is also equipped with an asynchronous RAM which allows to perform real time acquisition of the main control variables. The DSP has many integrated control

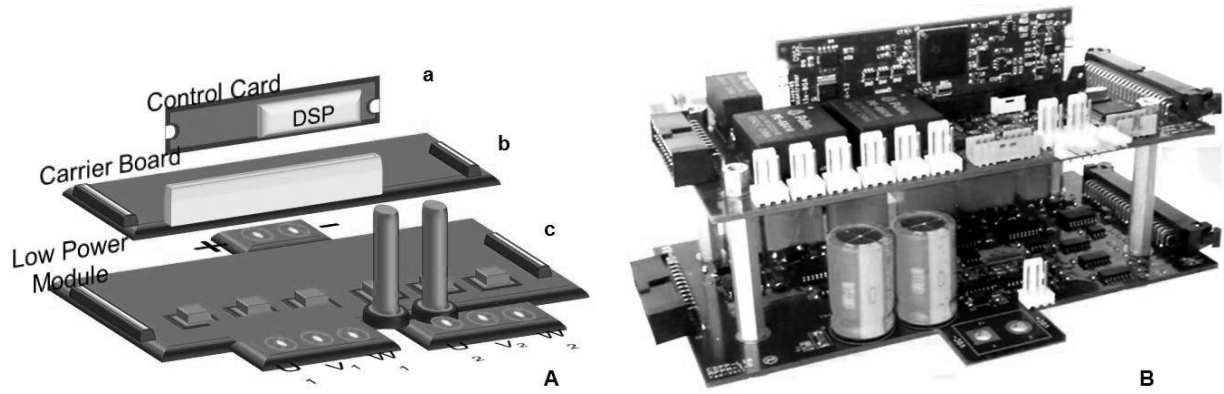

Figure 1. A) MPPM scheme: a) Control Card b) Carrier Board c) Low Power Module (LPM) B) real MPPM photo

peripherals like PWM signal generator, 16 ADC channels (12bit), 32 bit timers, capture and quadrature encoder modules and communication peripherals like a dual CAN core used, in this application, to interface different MPPM systems to a main controller or/and a host PC.

The Carrier Board hosts the DSP Control Card; it is equipped with analog and digital conditioning circuits and provides power supplies needed by the DSP and the Low Power Module. The DSP is supplied with 5V while the gate drivers need power supplies between -8V and +16V which are generated by on-board DC/DC converters.

Each phase leg is provided with isolated power supply. High side and low side commands are implemented on Carrier Board with minimum controlled dead time to avoid cross conduction; additional dead time can be added by software in the DSP PWM generator peripheral.

Protection circuits are implemented on the same board to protect phase legs from over-temperature, short circuit, under and over-voltage. This configuration allows MPPM system to drive also up to two three-phase electric motors. For this reason the Carrier board is also equipped with Hall sensors, ABZ encoder and resolver conditioning circuits.

The Low Power Module (LPM) is based on a double three phase leg architecture (Figure 2) implemented using six Hyper-FET FMM110-015X2F components, with the

following ratings:

- up to 150V of DC link voltage
- up to 53A
- 20mΩ of  $R_{DSon}$

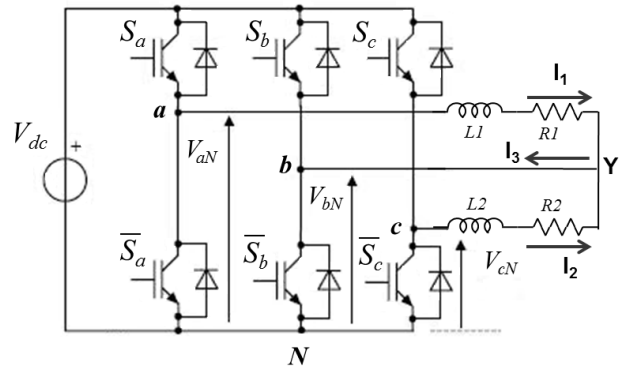

Figure 2. Basic architecture of a three phase leg module used to drive two loads

### III. DRIVE TECHNIQUE

The control of one axis AMB actuator is normally performed by using a classical 2-phase inverter with two nested loops, the inner one to achieve a direct actuator effort (force) while the outer to compensate the position error of the suspended mass from the nominal air-gap.

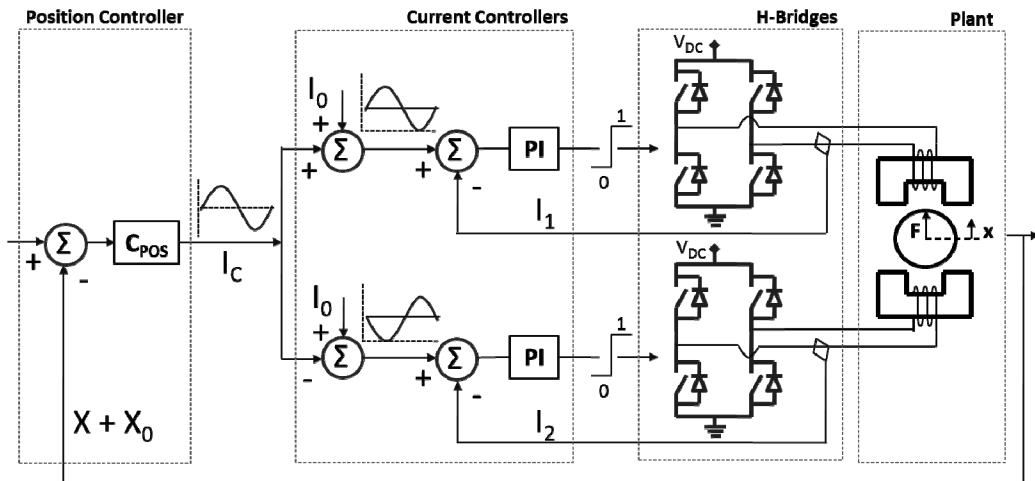

Figure 3. Classical H-bridges technique overall scheme

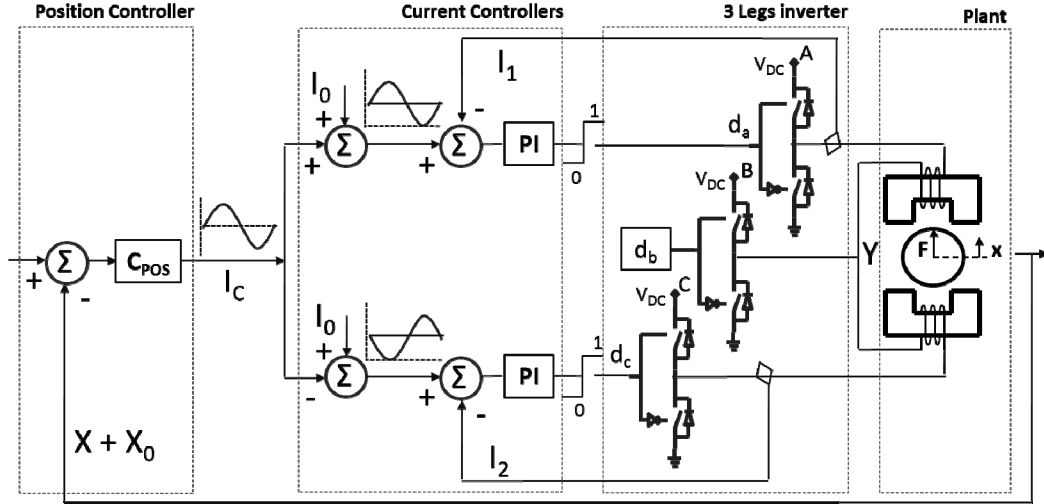

Figure 4. 3-Phases module load interconnection scheme

Hence, the driving of one axis is performed with two separate H-bridges. The outer controller computes reference for the inner current loop starting from the position error.

To exert a positive force on the rotor, current  $I_1$  in the upper coil is increased by the control current  $I_C$  while the current in the lower coil  $I_2$  is decreased by current  $I_C$  and vice versa for negative forces. A constant bias current  $I_0$  is applied to both coils, to linearize the current to force characteristic of an electromagnet.

$$\begin{aligned} I_1 &= I_0 + I_C \\ I_2 &= I_0 - I_C \end{aligned} \quad (1)$$

The architecture proposed in this work, allows to perform the same control action for a complete magnetic bearing axis with a single three-phase inverter instead of two separate H-bridges.

The basis for this new method is the projection of the three-phase quantities onto two-axis components. Accordingly, the bias current  $I_0$  and the control current  $I_C$  are transformed into the phase currents  $I_1, I_2$  and  $I_3$ .

The basic architecture of this technique is illustrated in Figure 2 while coils connections are exposed in Figure 4.

#### IV. EXPERIMENTAL RESULTS

The proposed technique is actually under test on an experimental test rig performing an active magnetic damping action. The behavior is perfectly similar to active magnetic bearing in terms of control and driving technique, except for a mechanical stiffness which allows the system to be intrinsically stable.

This case of study fits well with the explanation of the proposed technique but does not allow to provide details about the communication between multiple modules, since the application does not require it. However, this feature is dealt with in next section.

Figure 5.A and Figure 5.B show the setup used for the experimental characterization. A stiff aluminum arm is hinged at one end while the other end is connected to the moving part of the damper. The geometry adopted for the damper is the same of a heteropolar magnetic bearing.

This leads to small stray fluxes, and makes the one-

dimensional approximation acceptable for the analysis of the circuit. The mechanical stiffness required to compensate the negative stiffness due to the electromagnets so to avoid instability is provided by two sets of coil springs.

Two sets of three cylindrical coil springs are used to provide the arm with the required stiffness. They are preloaded with screws that allow to adjust the equilibrium position of the arm. Attention has been paid to limit as much as possible the friction in the hinge and between the springs and the base plates. To this end the hinge is realized with two ball bearings.

The contact between adjustment screws and the end of adjusting screws is realized by means of steel balls. Mechanical stops limit to  $\pm 5$  degrees the oscillation of the arm relative to the centered position.

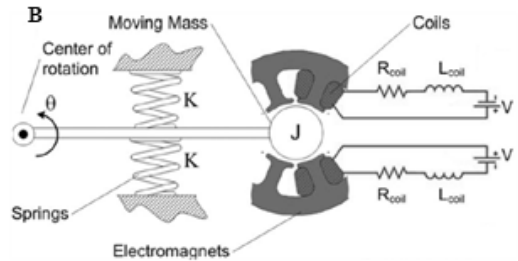
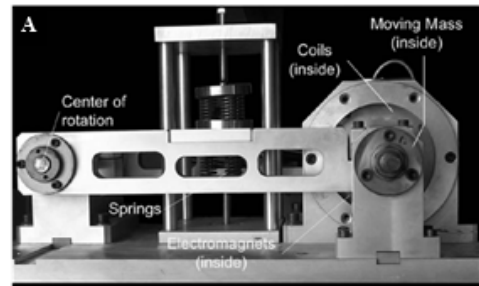

Figure 5. Single degree of freedom test bench.  
A) Test bench; B) Sketch

The value of the additional resistance can be modified to tune the electrical pole frequency. The natural frequency of the mechanical system can be modified

selecting coil spring with appropriate stiffness. During tests the mechanical frequency was set at 19 Hz and the electrical pole at 10.9 Hz. The main numerical parameters of the experimental setup are collected in Table 1.

TABLE I  
TEST RIG MAIN PARAMETERS

Symbol	Value	Unit
<b>Mechanical parameters</b>		
k (Mechanical stiffness)	46.5	kN/m
m (Mass)	3.42	kg
$c_0$ (Damping)	0	Ns/m
<b>Actuators parameters</b>		
N (Number of turns)	98	-
Airgap ( $x_0$ )	0.6	mm
Airgap Area (A)	4.8e-5	m <sup>2</sup>
R (Coil resistance)	0.4	$\Omega$
$L_0$ (Coil inductance)	8.9	mH
$k_f$ (Force-current factor)	7.39	N/A
$k_m$ (Back-electromotive force factor)	7.39	Vm/s
$k_x$ (Negative stiffness)	-6.16	kN/m

The position was measured with a Bently Proximitor 3300XL eddy current sensor. AMP25 Hall current sensors (range  $\pm 5$  A) were used for the current measurement in the two coils (lower than 100 mA, peak-to-peak, of noise).

The DC value of the PWM power amplifier was set to 20 V, and the switching frequency was set to 36.6 kHz. Thus, as both the sampling rate and the switching frequency of the PWM were far above the mechanical frequency of the system (around 20 Hz), their dynamics was neglected during the study.

The experimental tests have been performed to validate the effectiveness of the approach and to prove that the proposed technique acts as the standard method.

In Figure 6 the measured displacements during impact test in open and closed loop are illustrated. It is visible that the first mode is well controlled. However an harmonic oscillation is present both in closed and in open

loop. This is due to the second dynamic of the plant which is not controlled. The comparison between the H-bridges and three-legs inverter approaches is not shown here because the responses are perfectly superimposed.

This allows to conclude that the proposed method permits to save electronics with respect to standard configuration obtaining the same performance level.

## V. COMMUNICATION NETWORK

The proposed architecture allows to drive two pairs of opposite electromagnets which is a typical configuration used for the control of rotating machines equipped with magnetic actuators. As a matter of fact, the control of rotors is performed with two actuation stages for radial displacements and one actuation stage for axial displacement.

A special configuration is the one with conical actuators which allow to obtain radial and axial control by means of just two actuation stages. Indeed the approach described in this paper allows to drive a whole actuation plane with one actuation module. The full architecture is then composed of three MPPM modules for classical configurations (two radial and one axial) or of two for conical ones.

Furthermore, depending on the implemented control strategy, the control can be performed with centralized SISO control laws or with a centralized MIMO approach. In the first case the control loops (current and position) are closed locally and there is no need for communication between the control units.

In the second case, on the contrary, since a single control law provides the commands for all the actuators, a communication with the central control unit is required to share data necessary for the control action. Hence the electronic architecture here proposed allows to perform three different control approaches, summed up graphically in Figure 7.

a) Decentralized control: three MPPM modules are required (two for conical actuators), one for each actuation stage; the current control is performed locally for each actuator as well as the position control performed with a SISO strategy. No communication between the modules is required.

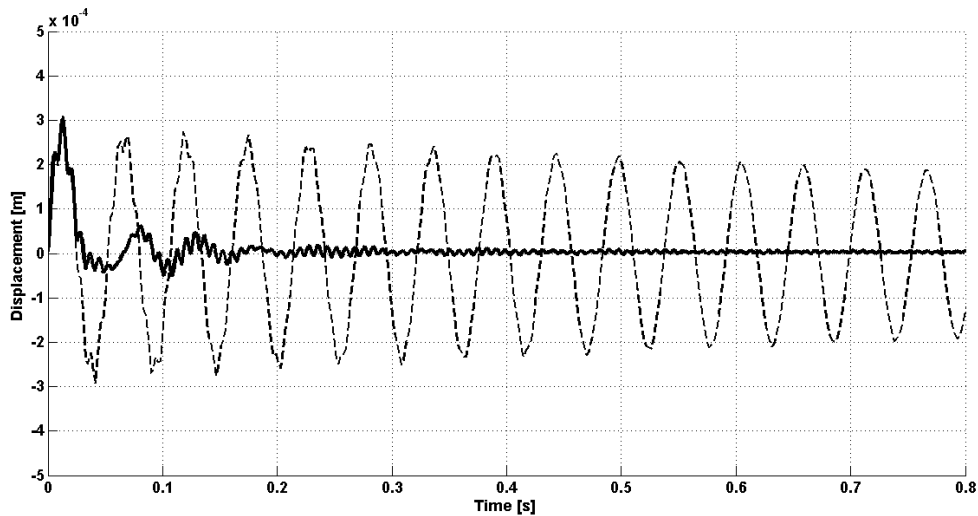

Figure 6. Position time response. Solid line: Closed loop response. Dashed line: Open loop response.

This solution is recommended when a classical control action on the rotating machine is required and in particular there are no stringent requirements about robustness. In Figure 7 the blocks involved in this kind of solution are: Plant, MPPM\_1 and MPPM\_2. The communication with Host\_PC block can be performed for control activation, monitoring and diagnostics.

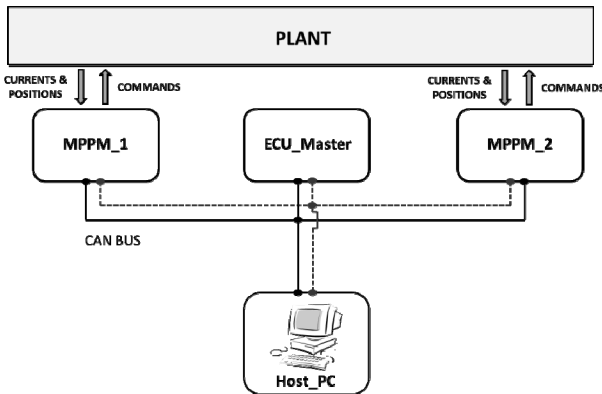

Figure 7. Communication architecture.  
Solid line: Shared CAN bus for position measurements  
Dashed line: Shared CAN bus for position references

a) Decentralized control: three MPPM modules are required (two for conical actuators), one for each actuation stage; the current control is performed locally for each actuator as well as the position control performed with a SISO strategy. No communication between the modules is required. This solution is recommended when a classical control action on the rotating machine is required and in particular there are no stringent requirements about robustness. In Figure 7 the blocks involved in this kind of solution are: Plant, MPPM\_1 and MPPM\_2. The communication with Host\_PC block can be performed for control activation, monitoring and diagnostics.

b) Decentralized control with no master control unit: the number of MPPM modules is the same of the previous case as well as the control actions. In this case a communication between the control units is possible by means of a shared CAN channel. All components in Figure 7 are used except the ECU\_Master block. This solution is suggested when a decentralized control with SISO strategy is required but each control unit need information of all the plant.

c) Centralized control with a master control unit: in this case the number of required MPPM modules is three (two for conical) plus a further control unit which acts as master (ECU\_Master block in Figure 7). Current controls keep to be performed locally by the MPPM, position measurements and commands are sent separately on the two shared CAN channels. The master is supposed to perform a centralized MIMO control action on the position, the Host\_PC keeps playing the user interface role. This solution is designed to face the need of accuracy in the control and to allow the design of centralized robust and weighted strategies.

## VI. CONCLUSION

In this paper the design and the realization of a multi-purpose electronic architecture able to drive electrical

loads with three-phase legs in place of the standard H-bridges has been exposed. As shown, this technique allows to save electronics by keeping the same performance level. The study has been performed on a single degree of freedom mechanical oscillator provided with a mechanical spring. The system acts as a damper by using a couple of opposite magnetic actuators.

The modeling approach used and the experimental results obtained are reported in order to prove the effectiveness of the approach. Finally, the communication architecture between different modules and with eventual master control unit and user interface has been described in the case of rotating machines control.

## ACKNOWLEDGEMENT

This research was funded by Regione Piemonte within Polo della Meccatronica (MESAP), Project APMD (Active and Passive Magnetic Devices).

## REFERENCES

- [1] [1] Kasarda, M., Johnson, M., Imlach, J., Mendoza, H., Kirk, G., and Bash, H., 2000, "Applications of a magnetic bearing acting as an actuator in conjunction with conventional support bearings," Proceedings of the Ninth International Symposium on Magnetic Bearings, University of Kentucky, 3-6 Aug., Lexington, KY, pp. 1-6.
- [2] Vance, J. M., Ying, D., and Nikolajsen, J. L., 2000, "Actively controlled bearing dampers for aircraft engine applications," ASME J. Eng. Gas Turbines Power, 122(3), pp. 466-472.
- [3] Tonoli A., Amati N., Bonfitto A., Silvagni M., Staples B., Karpenko E., "Design of Electromagnetic Dampers for Aero-Engine Applications", Journal of engineering for gas turbines and power, 132(11), 112501-1 - 112501-11.
- [4] Genta, G., Tonoli, A., Amati, N., Macchi, P., Silvagni, M., and Carabelli, S., 2006, "More electric aeroengines: tradeoff between different electromagnetic dampers and supports," Tenth International Symposium on Magnetic bearings, EPFL, 21-23 Aug., Martigny, Switzerland.
- [5] Maruyama Y, Mizuno T, Takasaki M, Ishino Y, Ishigami T, Kamenno H. Estimation method and measurement bandwidth of gyroscopic sensor using active magnetic bearing. In: Proceedings of annual conference of the IEEE industrial electronics society; 2007. p. 2230-2235
- [6] Schweitzer G., Bleuler H., Traxler A., "Active Magnetic Bearings", vdf Hochschulverlag ac an der ETH Zurich, Zurich, 1994.
- [7] Schweitzer G., Maslen E., "Magnetic bearings: theory, design and applications to rotating machines", Springer, Berlin, 2009.
- [8] Chiba A., Fukao T., Ichikawa O., Oshima M., Takemoto M., Dorrell D.G., "Magnetic Bearings and Bearingless Drives" Elsevier, Oxford, 2005.
- [9] Mizuno T, Higuchi T. Design of the control system of totally active magnetic bearings – structures of the optimal regulator. In: Proceedings of international symposium on design and synthesis; 1984. p. 534-539.
- [10] Thibeault, N. M., Smith, R., 2002, "Magnetic bearing measurement configurations and associated robustness and performance limitations," J. Dyn. Syst., Meas. Contr., 124, pp. 589-598.
- [11] Noh, M. D., and Maslen, E. H., 1997, "Self-sensing magnetic bearings using parameter estimation," IEEE Trans. Instr. Meas., 46(1), pp. 45-50.
- [12] Mizuno, T., Araki, and K., Bleuler, H., 1996, "Stability analysis of self-sensing magnetic bearing controllers," IEEE Trans. Contr. Syst. Tech., 4(5), pp. 572-579.
- [13] Tonoli, A., Bonfitto, A., De Lépine, X., Silvagni, M., 2009, "Self-sensing Active Magnetic Dampers for vibration control", J. Dyn. Syst., Meas. Contr., 131, pp.
- [14] Walter H., Denk J., Stoiber D., Kopken H.G., "Industrialization of AMB system with standard drive technology", PCIC Europe, Jun 15-17, 2010, Oslo, Norway.