



Politecnico di Torino

## Porto Institutional Repository

[Proceeding] Time Domain Reflectometry Coaxial Probe for Water Content Measurements of Soil

*Original Citation:*

M. Hajj Yahya; P. Savi; D. Canone; S. Ferraris (2012). *Time Domain Reflectometry Coaxial Probe for Water Content Measurements of Soil*. In: 4th EGU Leonardo Conference: Hydrology and Society, Torino, November 14-16.

*Availability:*

This version is available at : <http://porto.polito.it/2503098/> since: October 2012

*Terms of use:*

This article is made available under terms and conditions applicable to Open Access Policy Article ("Public - All rights reserved") , as described at [http://porto.polito.it/terms\\_and\\_conditions.html](http://porto.polito.it/terms_and_conditions.html)

Porto, the institutional repository of the Politecnico di Torino, is provided by the University Library and the IT-Services. The aim is to enable open access to all the world. Please [share with us](#) how this access benefits you. Your story matters.

(Article begins on next page)

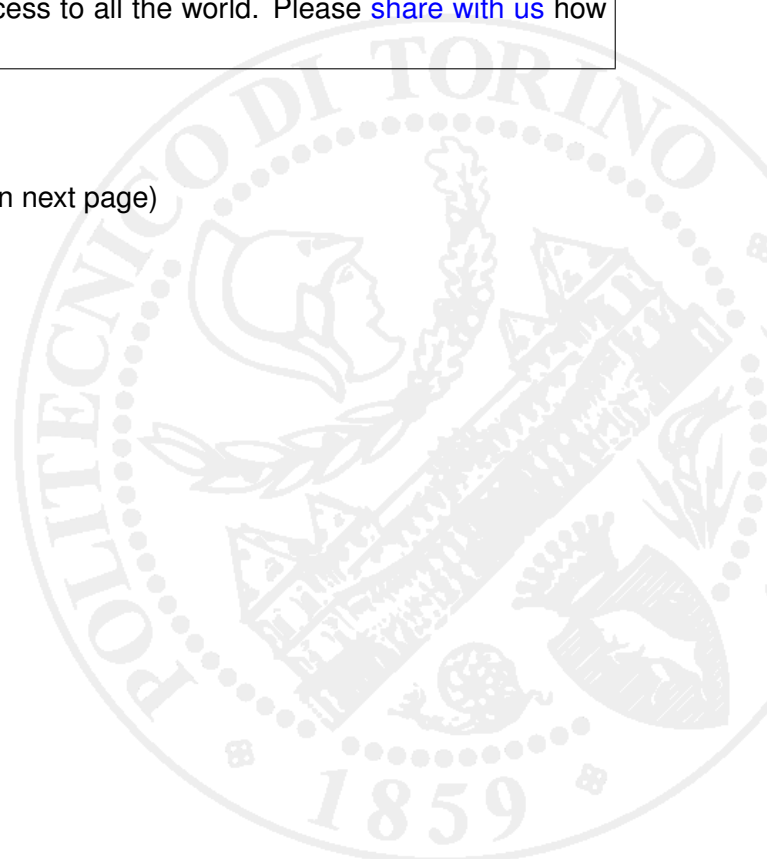



# TIME DOMAIN REFLECTOMETRY COAXIAL PROBES FOR WATER CONTENT MEASUREMENTS OF SOIL

M. Hajj Yahya, P. Savi, D. Canone, S. Ferraris

Department of Elettronics e Telecommunications (DET), Politecnico di Torino, Italy

Interuniversity Department of Regional and Urban Studies and Planning (DIST),

Politecnico e Università di Torino, Italy.

## ABSTRACT

Water resources are utilized for many human activities. However, there is often a mismatch between the water requirements and the withdrawal actually available and sustainable. This mismatch may become even worse as a consequence of climate change. In fact, climate change affect both water demand and water resources and it is highly probable that society will suffer increased water requirements without having a proportional increase of available water resources. Irrigation is demanding huge withdrawals of water. One region where these problems are self evident is North-Western Italy, where the water requirements for agriculture are important in large parts of the territory. Knowledge of water content is thus important for water resources management and risk prevention. Volumetric water content of soil may be measured in situ using Time Domain Reflectometry (TDR). The TDR measurement setup is mainly formed by a cable tester connected to a three-rod probe by means of a flexible coaxial cable.

The aim of this work was to develop a TDR coaxial-like probe that can be used for loose materials while ensuring optimum working conditions in terms of ease of insertion into and contact with the surrounding porous medium, and homogeneity and confinement of electrical energy storage.

First, the behaviour of a commercial coaxial probe was investigated with a laboratory TDR measurement setup. Then, a coaxial probe with eight brass blades long disposed along a cylinder and a stainless steel rod in the center was realized. Once calibrated, the new probe allows measuring volumetric water content within a small error range. The performance of the new probe was tested on various porous media.

## 1. LAB TDR MEASUREMENT SETUP



TEK TRONICS 1502C

Risetime: 0.3ns  
3dB Bandwidth 12MHz-1GHz  
Serial port

OR



HP 54120B Oscilloscope

Risetime 60ps  
3dB Bandwidth 10MHz-12GHz  
GPIB (IEEE 488.2 standard)

## LAB COAXIAL PROBE

Maury Microwave Airline (2653S10)



Length 10.5 cm  
shield conductor radii 3.5 mm  
Inner conductor radii 1.5 mm

## RESULTS

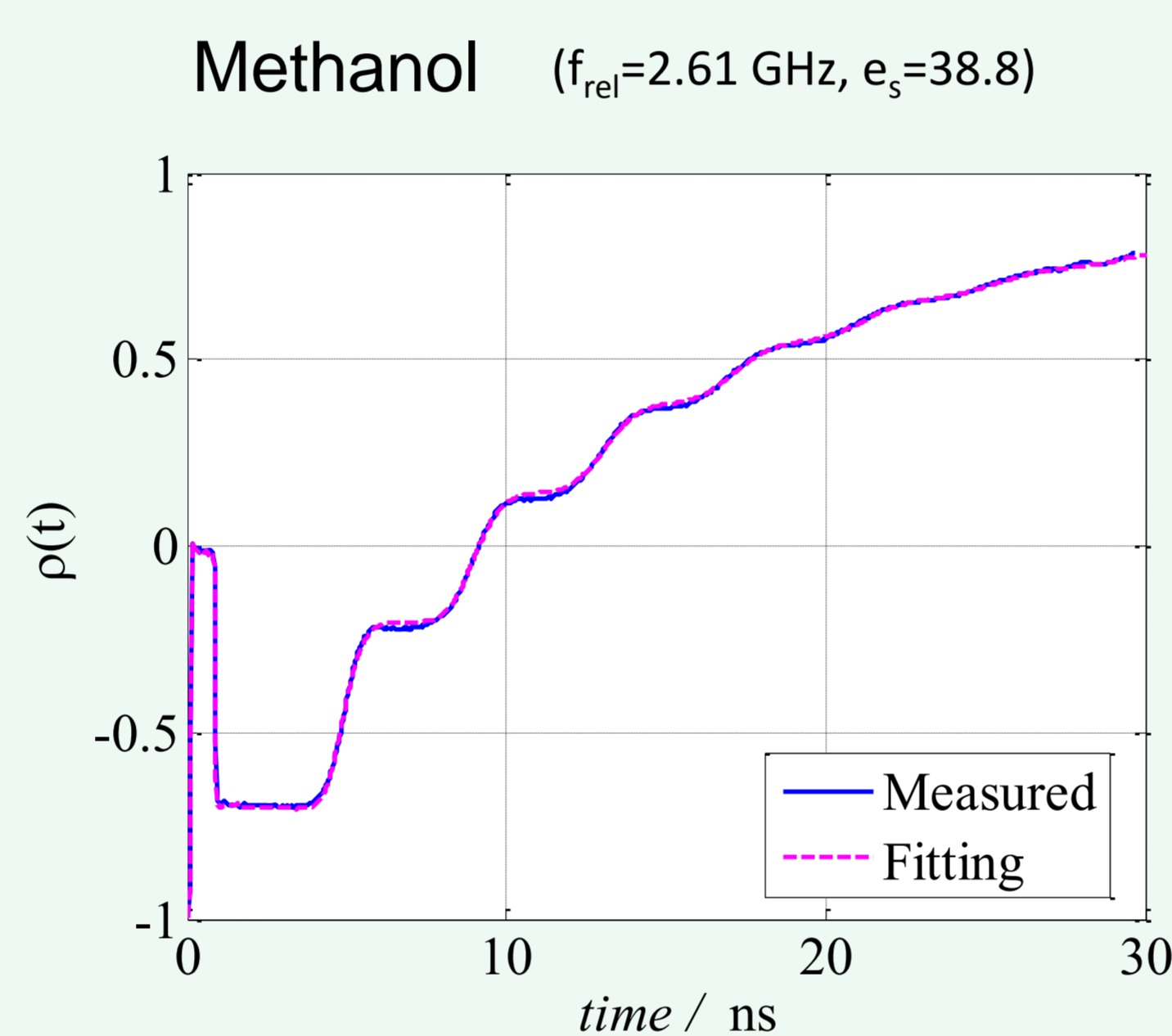

## Frequency Domain Model and Fitting by an inversion parametric approach (see [1])

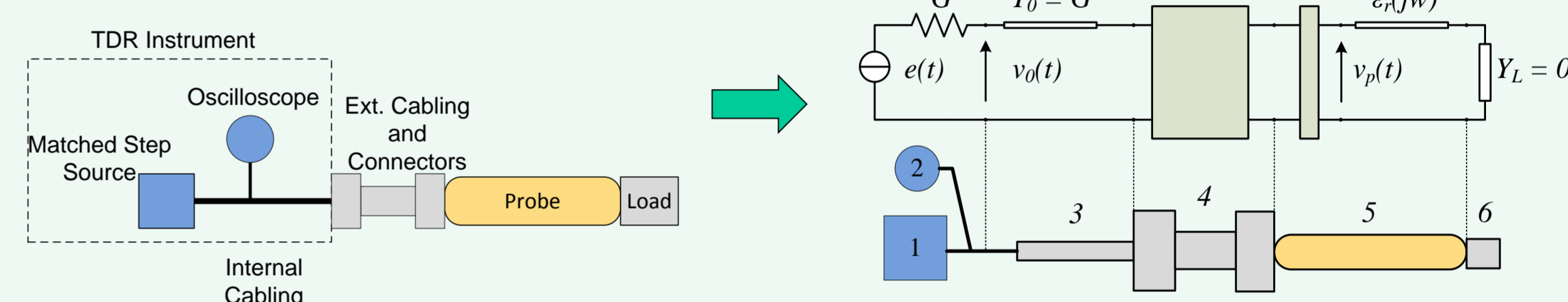

System	1 and 2	3	4	5	6
Model	Ideal step source and internal admittance	Ideal lossless TL	Lumped distributed 2-port element	2-port element and a lossy and dispersive TL	Open Circuit Load

## 2. IN-SITU COAXIAL PROBE

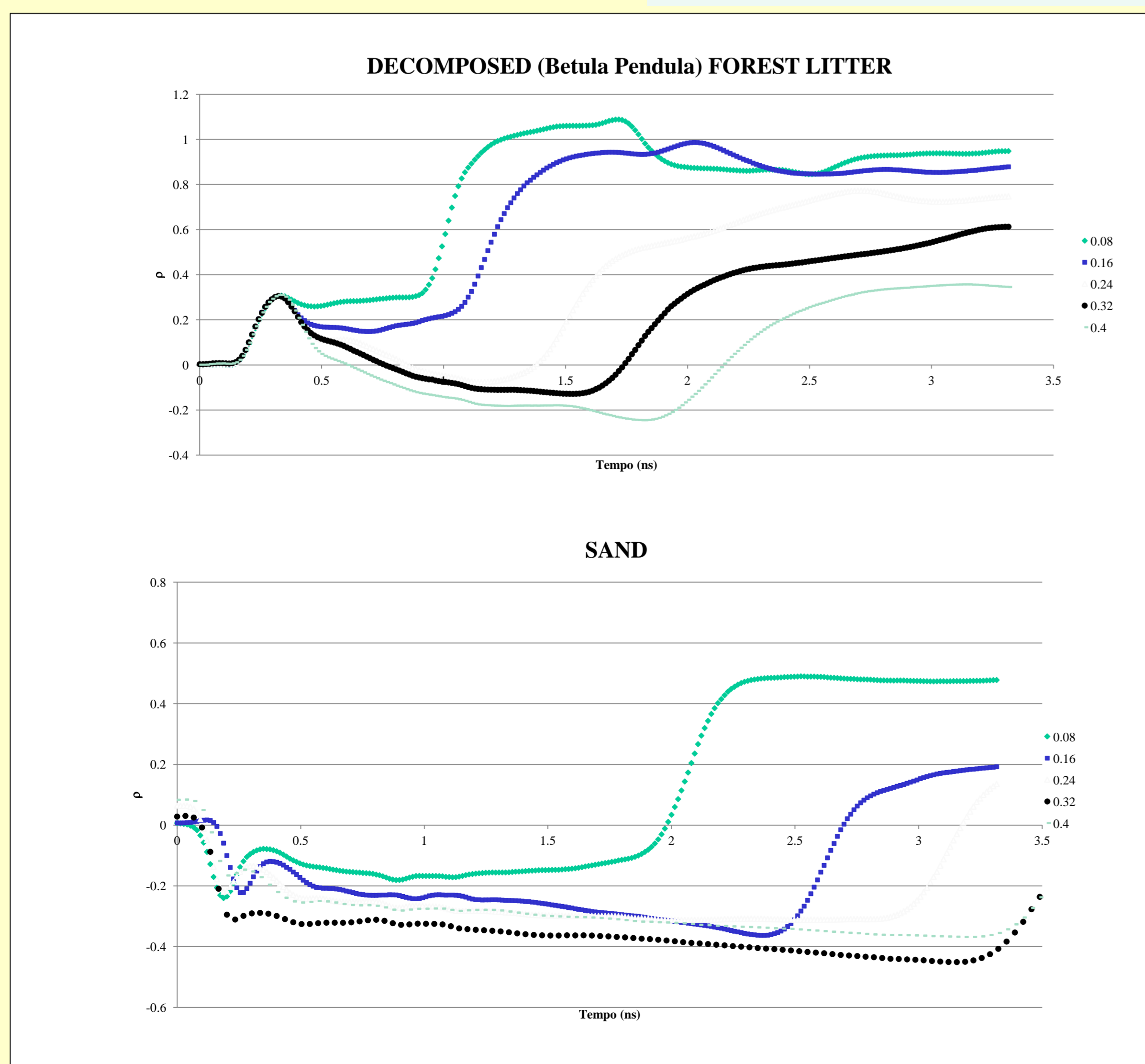
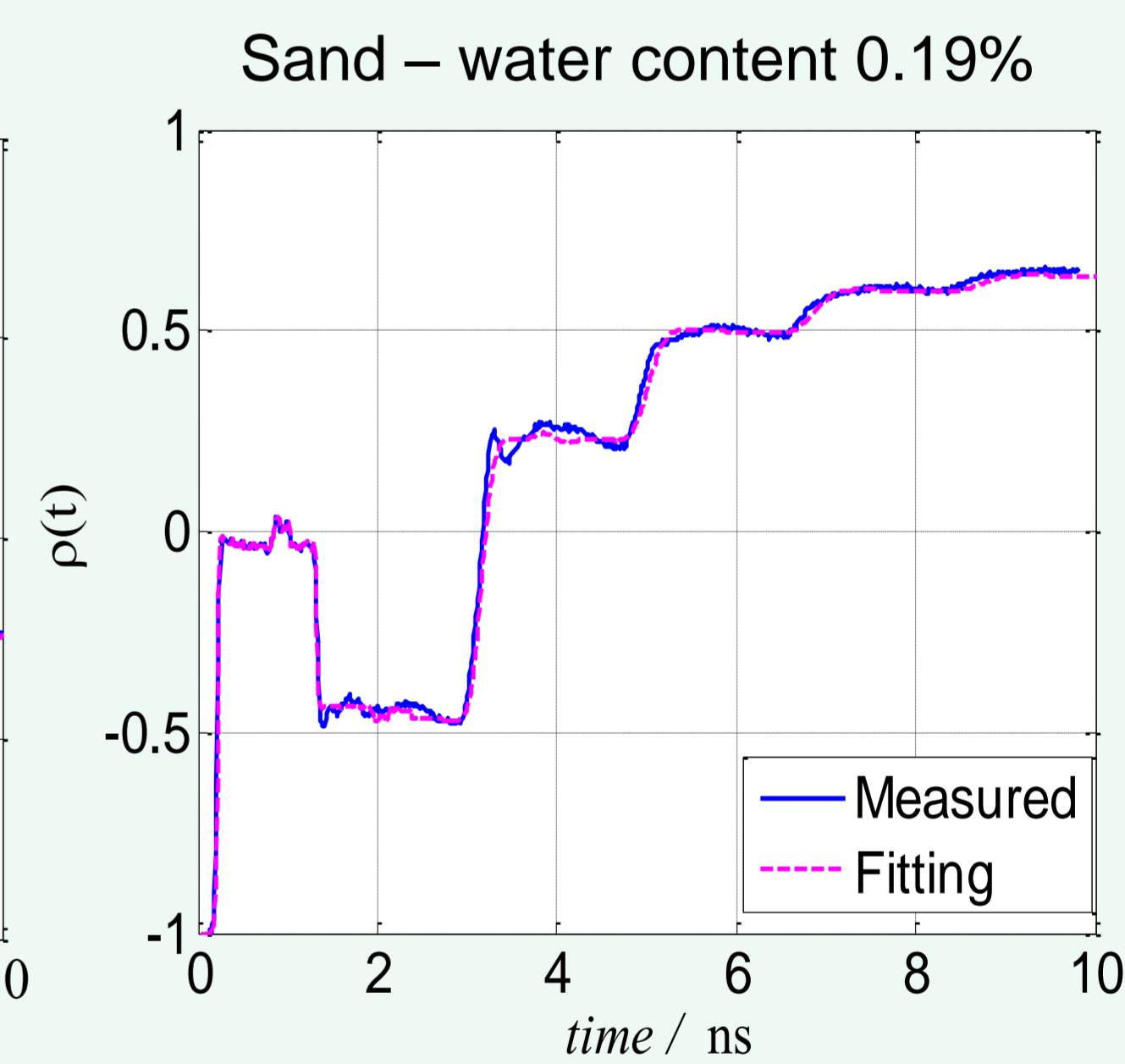
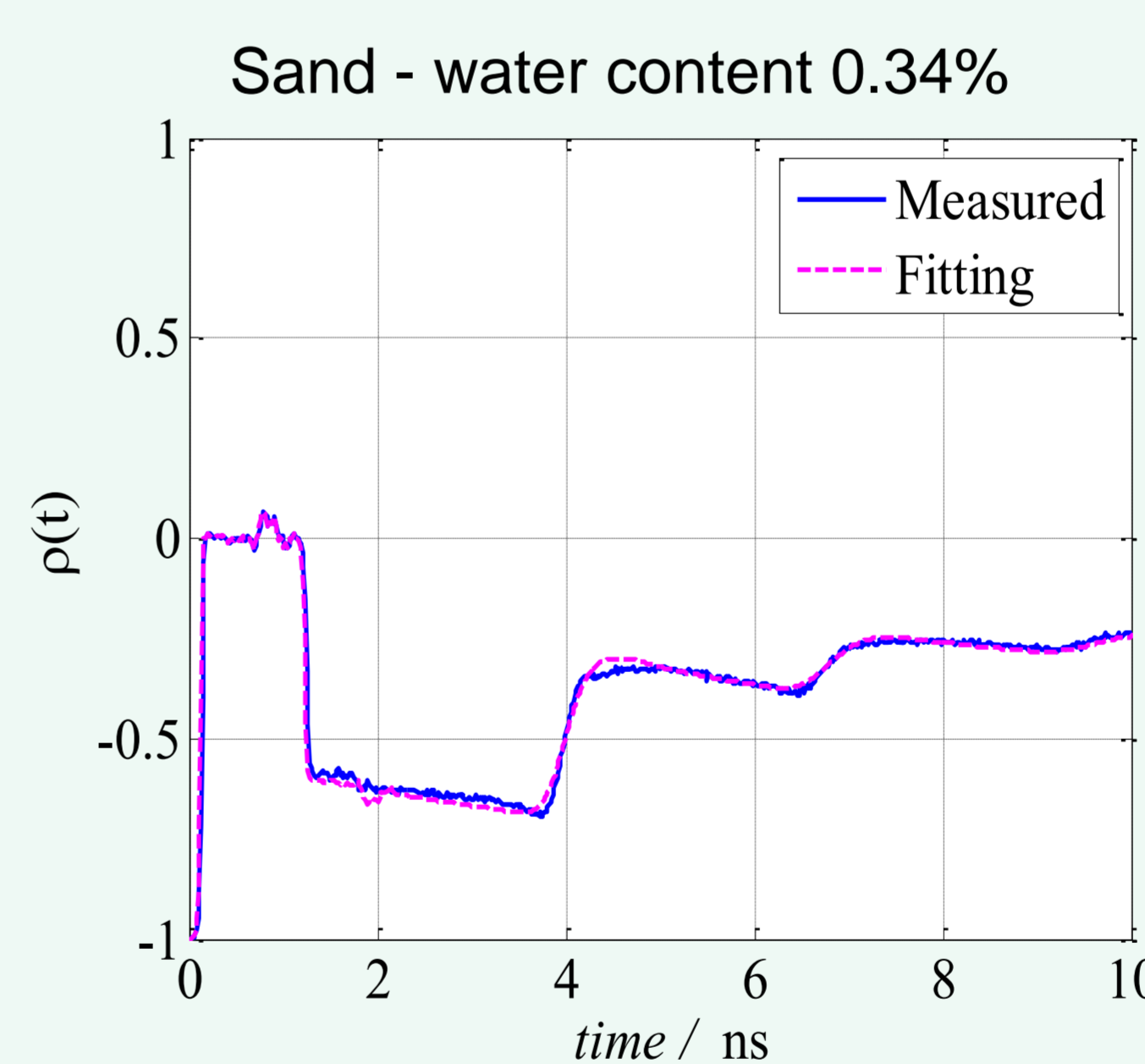
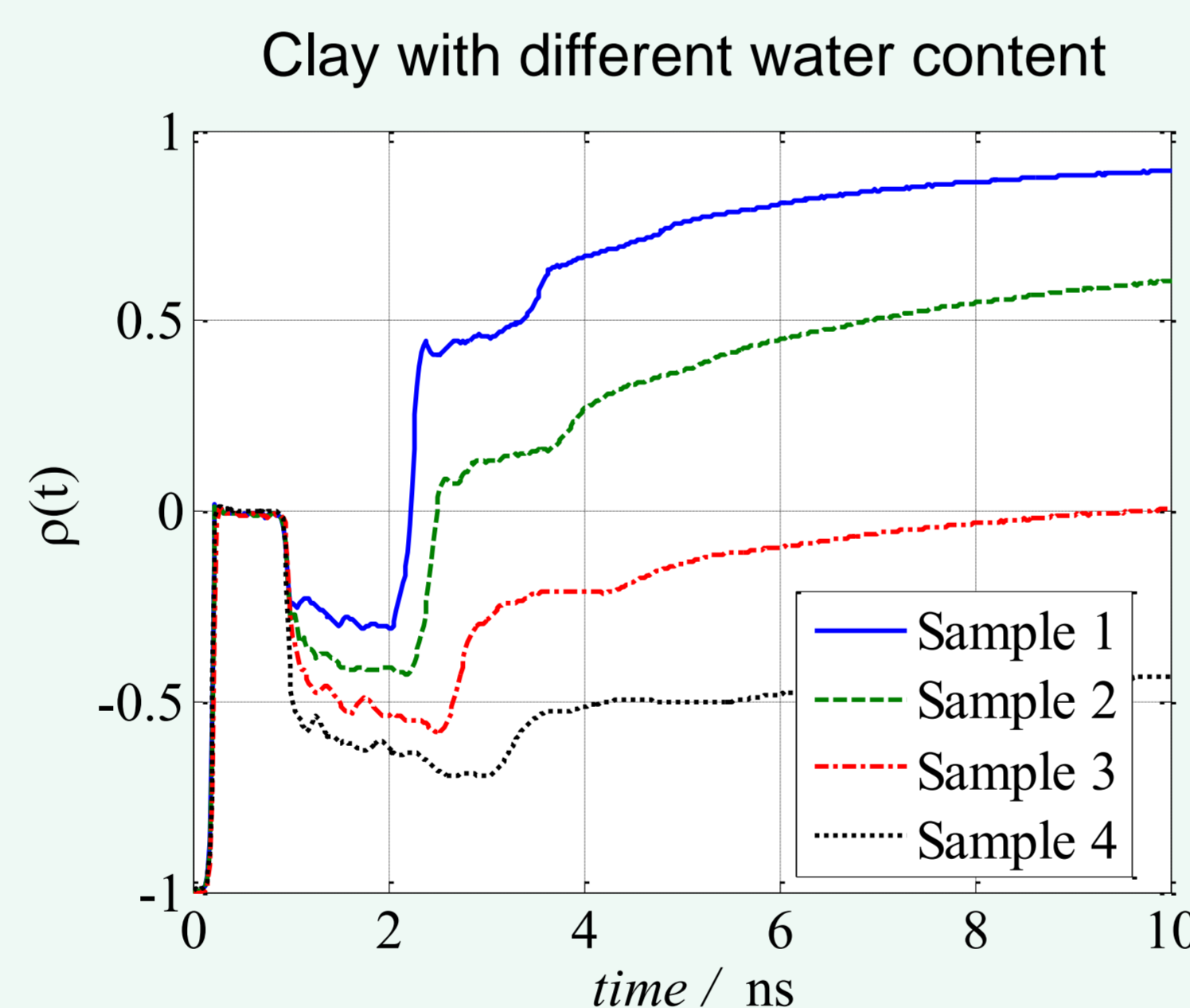
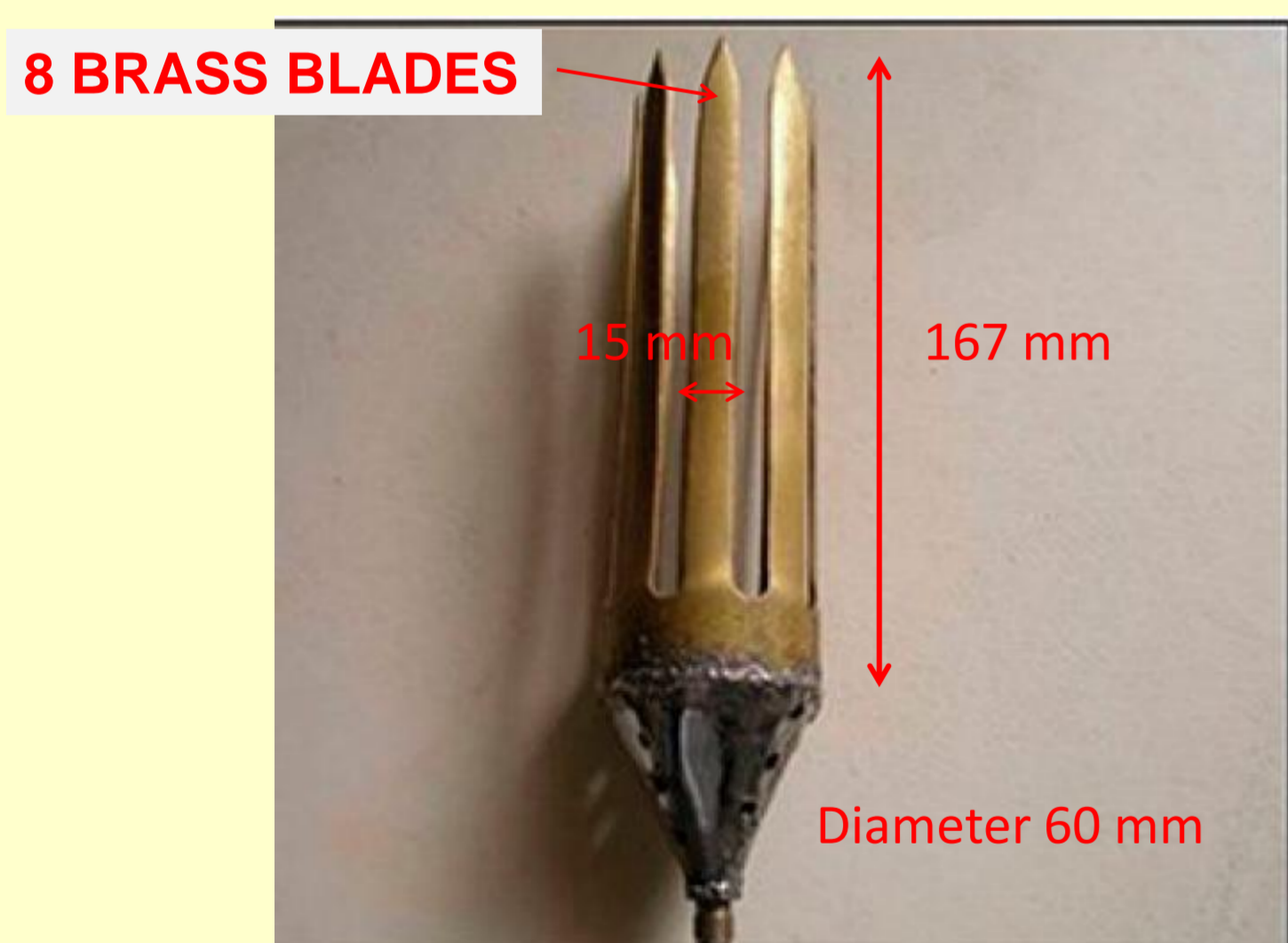

## CONCLUSIONS

The estimation of the dielectric permittivity of soil was first analyzed by using a commercial coaxial airline and a TDR laboratory measurement setup. A frequency domain method based on a transmission line model and a parametric inversion approach was applied to retrieve the permittivity.

Then a coaxial multi-blades TDR probe for measuring the permittivity and the water content was designed and tested. The multi-blades probe offers a good confinement of the electromagnetic field together with an easy use for soil applications. The new probe behaviour was investigated by means of in-situ measurements on decomposed forest litter and sand terrain.

## REFERENCES

- [1] Savi, P., Maio, I.A. and Ferraris, S., The role of probe attenuation in the TDR characterization of dielectrics, *Electromagnetics*, Vol. 30 (6), pp. 554-564, 2010.
- [2] Canone, D., Ferraris, S. and Haverkamp, R., A new coaxial Time Domain Reflectometry probe for water content measurement in forest floor litter, *Vadose Zone Journal*, Vol.10.2136/vzj2008.0110, pp. 363-372, 2009.