

This is the author post-print version of an article published on International Journal of Adhesion & Adhesives Vol. 40, pp.31–37, 2013 (ISSN 0143-7496),

DOI <http://dx.doi.org/10.1016/j.ijadhadh.2012.08.002>.

This version does not contain journal formatting and may contain minor changes with respect to the published version.

The present version is accessible on PORTO, the Open Access Repository of the Politecnico di Torino, in compliance with the publisher's copyright policy, as reported in the SHERPA-ROMEO website.

# **EXPERIMENTAL INVESTIGATION ON THE BENDING BEHAVIOUR OF HYBRID AND STEEL THIN WALLED BOX BEAMS – THE ROLE OF ADHESIVE JOINTS**

G. Belingardi, A. Scattina

Politecnico di Torino, Dipartimento di Ingegneria Meccanica ed Aerospaziale,

Corso Duca degli Abruzzi, 24 – 10129 Torino Italy

Phone +39-011-0906937

Fax +39-011-0906999

E-mail: [giovanni.belingardi@polito.it](mailto:giovanni.belingardi@polito.it)

## **ABSTRACT**

In the automotive design, nowadays there are two fundamental drivers. On one hand there are the environmental problems, on the other hand there are the safety matters. Within this contest, the weight reduction has become a key driver in the design of vehicles and it is necessary to consider and to study the use of non conventional materials taking advantage from their high potential of weight reduction and energy absorption capability.

In this perspective, the aim of this work is the study of the structural behaviour of box beams by means of a series of three points bending tests. The examined cross sections are those typically used in automotive construction. Different type of materials (steel, composite) and joining technologies (adhesive, spot weld) has been examined, considering different configurations. The work put in evidence the advantages coming from the use of adhesive, which allows structures with important weight reduction and better mechanical properties than traditional joining solutions.

**KEY WORDS:** three point bending test, hybrid structure, joining technologies.

## 1. Introduction

In the last years, in the automotive design, there are two fundamental drivers. On one hand the environmental problems are of more and more concern and, consequently, the need for vehicle weight reduction (that is inducing both reduction in fuel consumption and reduction in pollutant and greenhouse effect gas production [1, 2]) and, on the other hand, there are the safety matters [3-5].

For what concerns the safety problems nowadays the attention has mainly moved toward the protection for vulnerable road users (VRU i.e. pedestrians and cyclists) [6-8]. For this reason, specific impact tests and test protocols have been defined to assess the vehicle protection quality but also in order to get the prescribed homologation (European Directive 2003/102/CE) of the new cars. These aspects have had a heavy influence in the design of the front part of the new cars, which should be less aggressive against pedestrian, and the appropriate choice of materials can lead to interesting alternatives.

For these reasons, in the next future, well known and widely used materials like deep drawing steels will be progressively substituted by aluminium and magnesium alloys, and various types of polymeric and composite materials [9-18].

. The introduction of new materials could bring, with the weight reduction, some other improvements like higher stiffness and strength for the car body structure and cost reduction. At the same time many problems are linked to the introduction of new materials, one of them regards the joining techniques. For several years the car body assembly techniques were fully dominated by resistance spot welds, but this technology cannot be used to join different materials. Between the different alternatives, that

include mechanical joints such as screws, rivets, self piercing connections and clinch joints, the most promising is the use of structural adhesives.

This technology has a lot of advantages: it is a continuous joint, the adhesive layer produces additional insulation, protection and damping. Moreover it is possible to join different materials of almost any kind. The drawbacks of this technology could be represented by residual stress in the adhesive layer due to the differences in the thermal expansion coefficients of adherends and adhesive and the relatively long curing time, although the state-of-the-art structural adhesives have reached very interesting reticulation time. The problem can be solved by using the adhesive combined with other mechanical fastening or temporary fasteners. Summarizing, the major problem lies in incorrect design of the adhesive joint: a correctly designed and manufactured bonded joint is as reliable as other joining systems [19, 20].

Within this reference frame this work is oriented to study and compare innovative and traditional design solutions for structures of the front part of a car. In order to get results of general validity, simplified box beams similar to the typical structures used for the construction of a car body have been studied. In particular in the following, the behaviour of simple thin walled, square section columns made of two parts, when they are subjected to three point bending test has been examined. Beams with the classical top-hat section has been considered, the hat part is always made with deep drawing steel, while two different materials have been examined for the top part, namely a glass fibre reinforced composite and, for reference, the deep drawing steel. Two different technologies for the joining between the two parts of the beam have been studied (adhesive and traditional spot welding). The bending load has been chosen because it is the most representative of the load applied to the front structures of a vehicle, by the weight of the parts that the structure has a support, by the load due to the vehicle operation and also by possible impact against another vehicle or a vulnerable road user such as a pedestrian. In the literature different works regarding the bending of thin walled box beams have been presented [21-27], however usually the specimens are in a single part and there is no focus on the adopted joining technique between the different parts that constitute the beams.

## 2. Experimental set-up

The behaviour of three different types of top-hat box beam columns (figure 1) has been studied. The first type of specimen has the hat made of low carbon deep drawing steel (EN10130, material properties in table 1). This material is typically used for automotive applications. The plate is made of a composite laminate, in particular woven ( $0^\circ/90^\circ$ ) glass fibres impregnated with epoxy resin. The plates have been obtained with water cutting from larger sheets. They have not shown residual agents on the surfaces. The two parts have been joined together with structural adhesive, in particular the Loctite Hysol 9466 has been adopted. The properties of the epoxy resin for composite are reported, in tables 2. In the two other solutions both the hat and the plate have been made of the above described steel. In one case the two parts are joined together with structural adhesive: the Loctite Hysol 9514 adhesive has been used. In the other case (the whole steel solution) the plate has been joined to the hat with resistance spot weld along the side flanges. The step between the different spots is about 30 mm for a total number of 10 spot for each side. The dimensions of the top-hat specimens are: length of 300 mm, the side of the box section is 40 mm and the width of the flanges is 15 mm. The thickness of steel sheet and of the composite part is 1 mm.

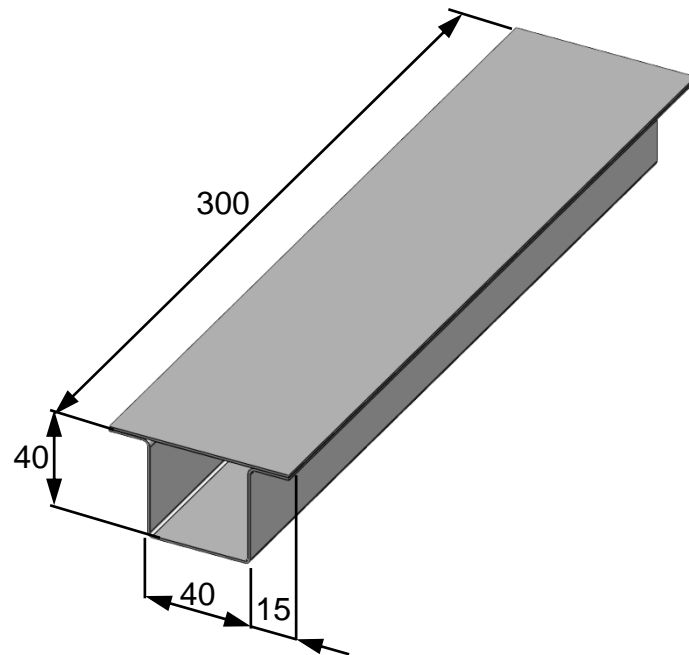

Figure 1: Box beams columns with dimensions

Table 1: Low carbon steel properties [28]

Steel EN10130	
Elastic modulus E (GPa)	206
Yield strength $\sigma_y$ (MPa)	170-280
Ultimate tensile strength $\sigma_u$ (MPa)	270-400
Elongation at failure $\epsilon_u$ (%)	25-30

Table 2: Properties of epoxy resin for composite (from material datasheet)

Epoxy resin		
Bending modulus (MPa)	ISO 178:2001	3100
Ultimate bending strength (MPa)	ISO 178:2001	120
Tensile strength (MPa)	ISO 527 1993	70
Elongation at failure (%)	ISO 527 1993	5
Charpy strength (kJ/m <sup>2</sup> )	ISO 179/1eU:1994	40
Hardness (Shore D15)	ISO 888:2003	83
Glass transition temperature (°C)	ISO 11359:2002	91

Both the adopted adhesives are structural epoxy adhesives. The Hysol 9514 is a one component adhesive and needs high curing temperature (180-200 °C) while the Hysol 9466 is a bi-component adhesive and is cured at room temperature. The choice of the adhesive has been done starting from previous experience and considering the type of adherends [28, 29]. The epoxy adhesives are the best choice in terms of mechanical performance and they are fully compatible with the considered type of adherends materials. Composite material could have some problems during cure at high temperature, for this reason an adhesive with cure at room temperature has been preferred. The properties of adhesives are summarized in table 3.

Table 3: Material properties of used adhesives (from adhesive datasheets)

ADHESIVE	Loctite® Hysol® 9514	Loctite® Hysol® 9466
Bulk modulus (ASTM D882, GPa)	1.46	1.718
Elongation (ASTM D882, %)	5.8	3
Tensile strength (ASTM D882, MPa)	44	32
Average shear strength (ASTM D1002-94, MPa)	50 (steel)	37 (steel)
Average shear strength (ASTM D1002-94, MPa)	40 (aluminium)	26 (aluminium)
Glass transition temperature (ASTM E1640-99, °C)	133	62

For what concerns the preparation of specimens for bonding, the cleaning with methyl ethyl ketone on the flanges of the specimen metallic parts has been followed by mechanical scouring with sandpaper while for the composite parts no particular treatments has been done. The adhesive has been coated on flanges then the two parts has been taken in place with mechanical fastening during the curing time.

The bending tests have been made, according to the ASTM C393-94, with the Zwick Z100 electro-mechanical universal material testing machine characterized by a maximum load capacity of 100 kN. The experimental set-up for the bending test is shown in figure 2. The distance between the two support points is 220 mm while the radius of punch is 100 mm. Quasi-static bending tests have been done, the travelling speed of the cross-head has been set to 0.5 mm/s. Even if these components are subjected also to dynamic crash load, with the aim of better understanding the global behaviour of the structure and of the adhesive joint it has been decided to investigate firstly their behaviour under quasi static loads.

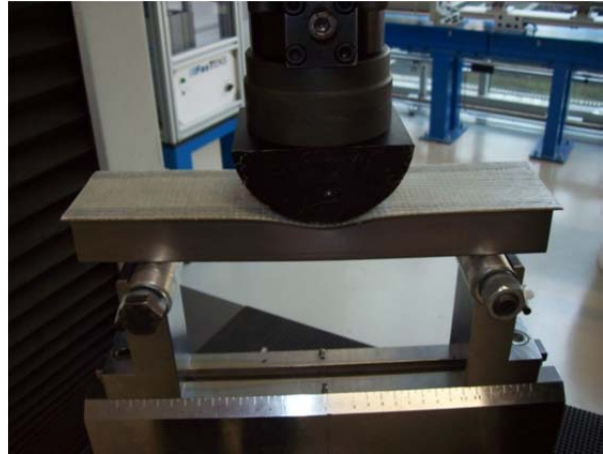
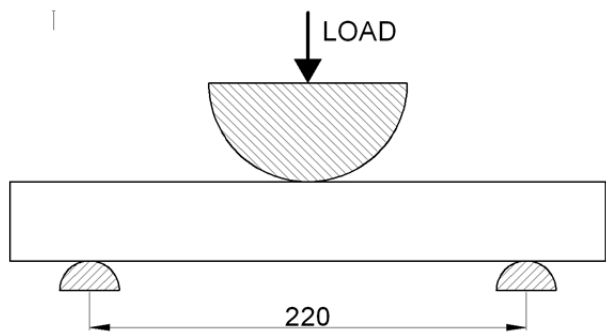

Figure 2: Experimental set-up

The boxed beam specimens have been tested considering both positions (top and bottom) for the plate part. Some tests have been done with the plate in the top position, as in figure 1 and figure 2 on the right, other tests have been done with the plate in the bottom position. In this way all possible design solutions have been considered, giving to the designers information about alternative conditions that can be encountered in the automotive applications. As a matter of fact, if we consider a structure such as a bonnet, the specimen with the plate in the top position appears to be more representative, while if we consider the bumper beam, the solution with the plate in bottom position is similar to conventional ones.

To better investigate the behaviour of the hybrid metal/composite specimens, some tests have been done applying strain gauges on the composite plate to measure the strain in the direction of the specimen axis and in the perpendicular direction. In this way, being the fibres oriented along the longitudinal and transversal axis of the specimen, the strains have been measured in the two directions of fibres. The position of the strain gauges on the composite plate is shown in figure 3.

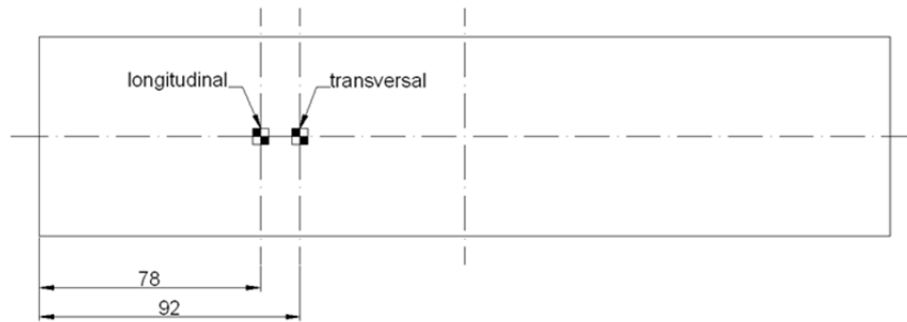

Figure 3: Position of strain gauges on the composite plate

### 3 Experimental results

The results of the experimental three points bending tests are summarized in figure 4,5 and 6. In figure 4 the average force displacement curves obtained during the tests for the different types of specimen examined are shown. These curves have been obtained as the arithmetic mean of the curves obtained in the different replication of the tests, in order to better compare in a single graph the behaviour of the different types of specimen. In the figure legend:

- the *composite* refers to beam made with the hat part of steel and the plate of composite material, with adhesive joining;
- the *adhesive* refers to beam wholly made of steel and with adhesive joining;
- the *spot weld* refers to beam wholly made of steel and with spot weld joining.

The energy absorbed during deformation as a function of the displacement (figure 5a) and the specific energy, calculated as the ratio between the absorbed energy and the weight of specimen (0.508 kg for the full metal columns and 0.366 kg for the hybrid specimen with a weight reduction of about 28%) (figure 5b) have also been evaluated. Finally in figure 6- there are the main parameters obtained from the curves. These parameters have been obtained in the following way:

- the *stiffness* is the slope of the first linear part of force-displacement curve
- the *elastic limit* is the load at the 2% divergence from the linearity again in the first part of the curve
- the *maximum load* is the maximum value of the load within the first 40 mm of displacement, which could be considered the gauge length of specimen.



The global trend of the curves is completely as expected: the first branch is linear, then a maximum is reached where the collapse of the rectangular section takes place.

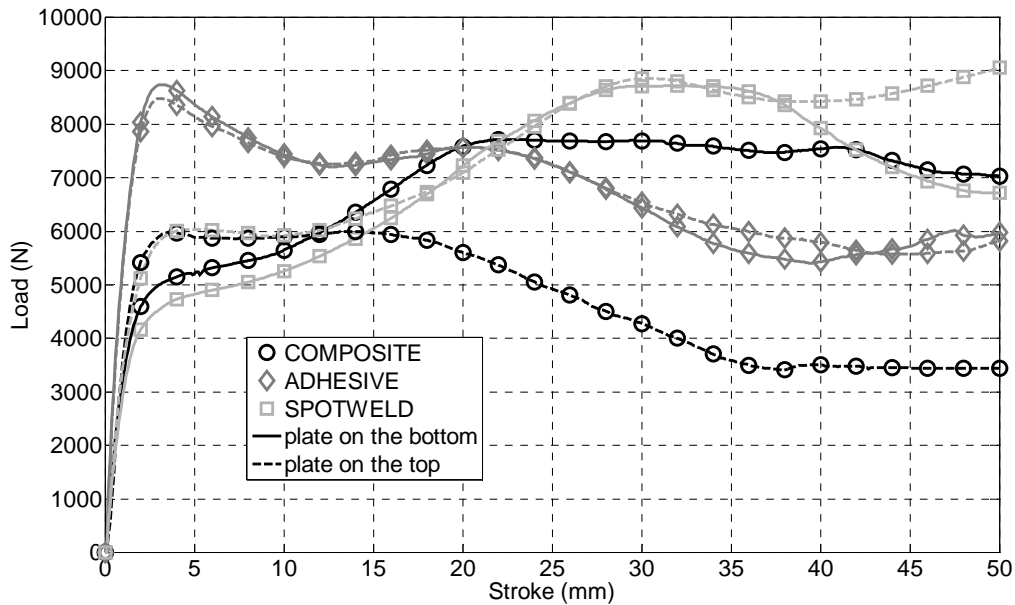

Figure 4: average force-displacement curves for the different typologies of specimens examined

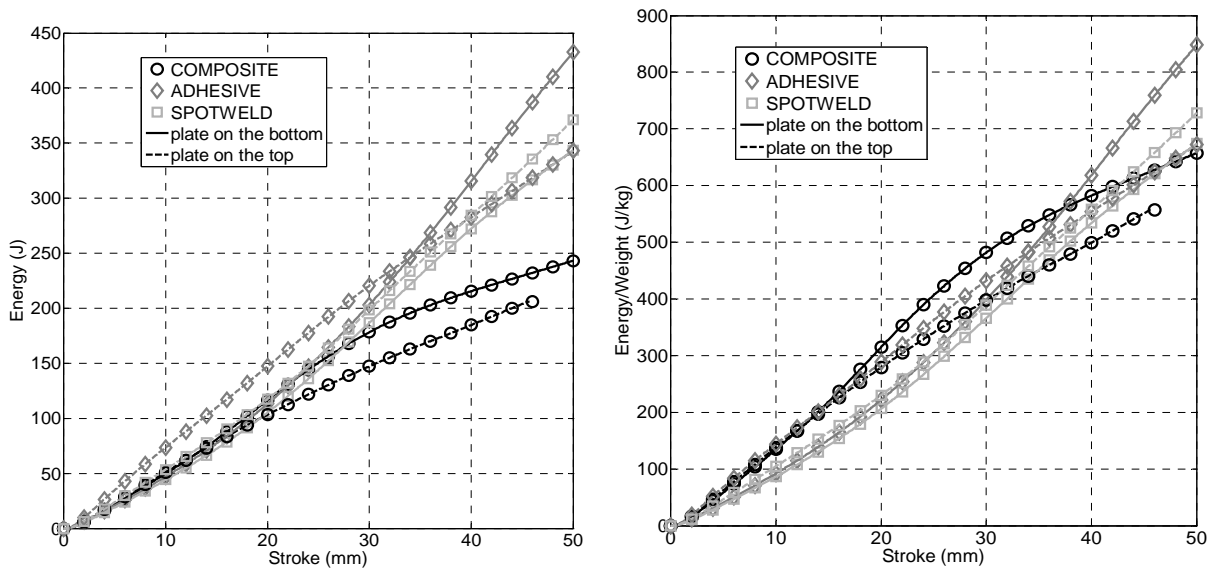

Figure 5: average curves of absorbed energy (on the left) and absorbed energy to specimen weight ratio (on the right) versus displacement

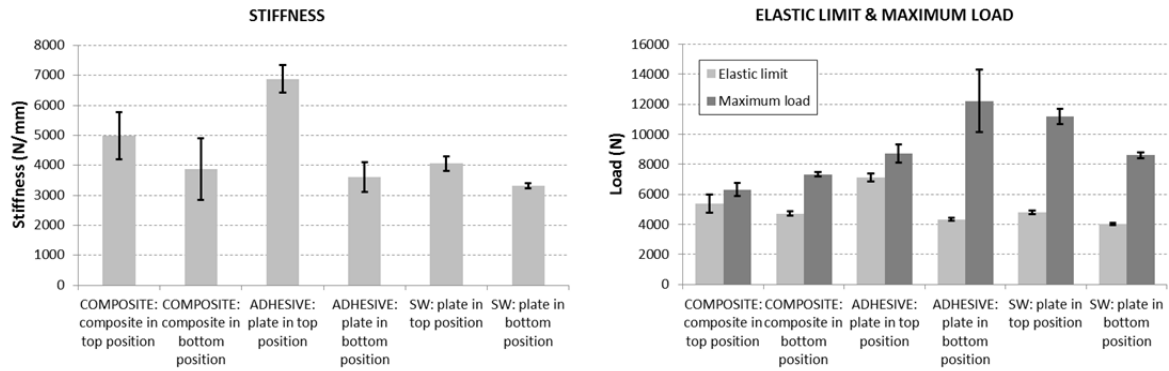

Figure 6: average values of stiffness (on the left) and elastic limit and maximum load (on the right) for the different types of specimen

### 3.1 Hybrid metal/composite specimens

The bending behaviour of this type of specimen are shown in figure 7 that collects all the force-displacement curves resulting from the performed tests, while in figure 8 the absorbed energy curves are shown. In figure 9 there are pictures of two specimens after the tests.

In the cases when the composite plate is at the upper side of the beam (the compression surface), a bending collapse of the plate takes place when its limit strength is reached; the collapse is characterised by the formation of two hinges, one around the transverse axis (as expected) and one about the longitudinal axis. Vice versa, in the cases when the composite plate is at the bottom side of the beam (the tensile surface), the collapse is characterised by the progressive failure of the composite plate. The results are quite repeatable as shown in the figure 7, in particular with the plate in the bottom position. The hybrid solution is slightly better than the all metallic ones in terms of stiffness and elastic limit, considering the solution with the plate in the lower position. The values of maximum load have been the lowest due to the presence of composite materials. However in the specimens with the plate in the top positions, the decrease of the load after the first peak ensure a more regular absorption of energy than the solution with the plate in the opposite position. The hybrid specimens allow slightly higher absorption of specific energy than full metal beams.

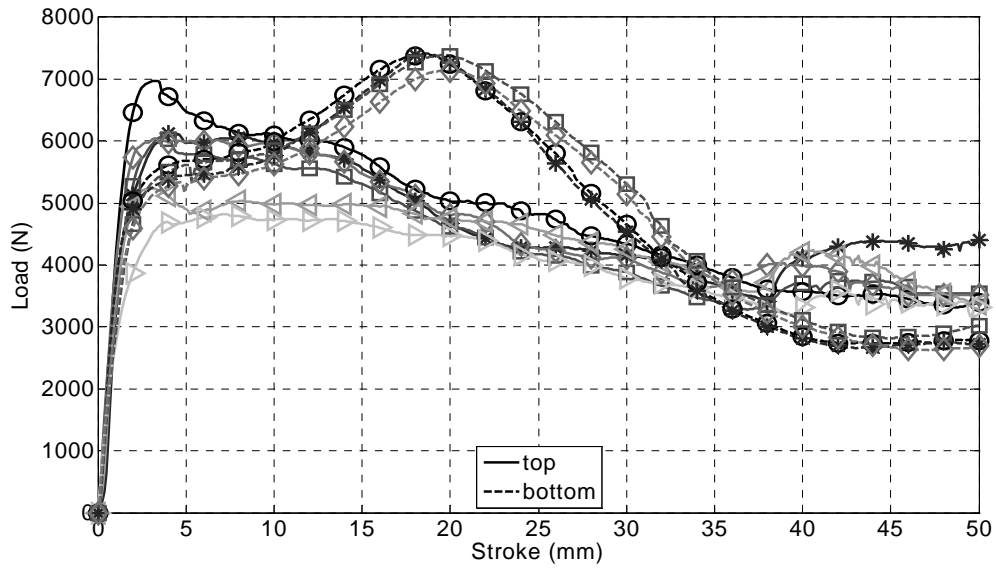

Figure 7: force-displacement curves for the hybrid composite-metal specimens examined

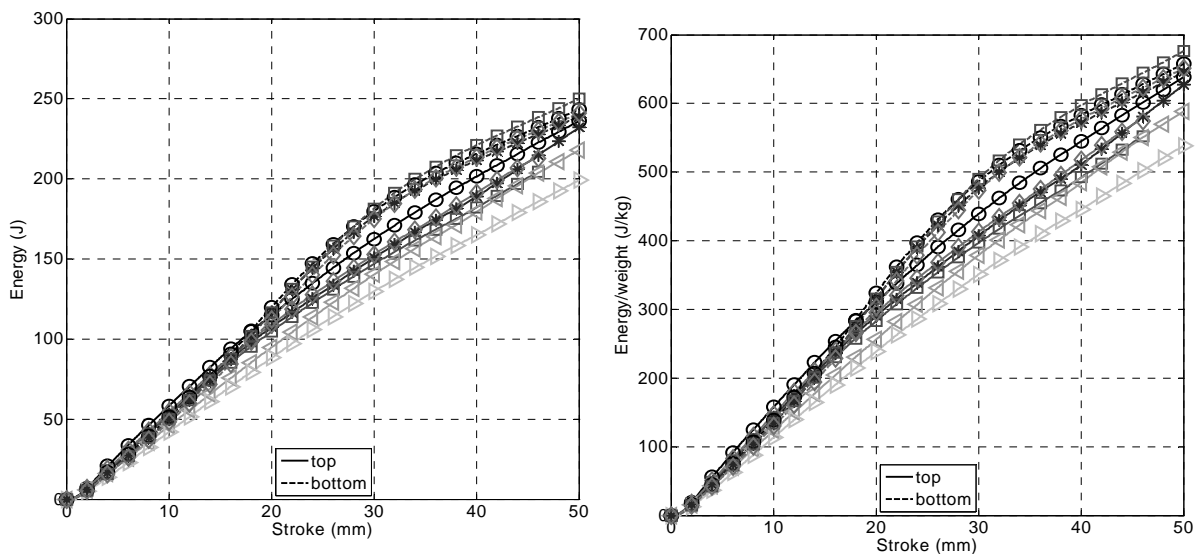

Figure 8: absorbed energy (on the left) and absorbed energy/weight of specimen (on the right) versus displacement for the hybrid specimens

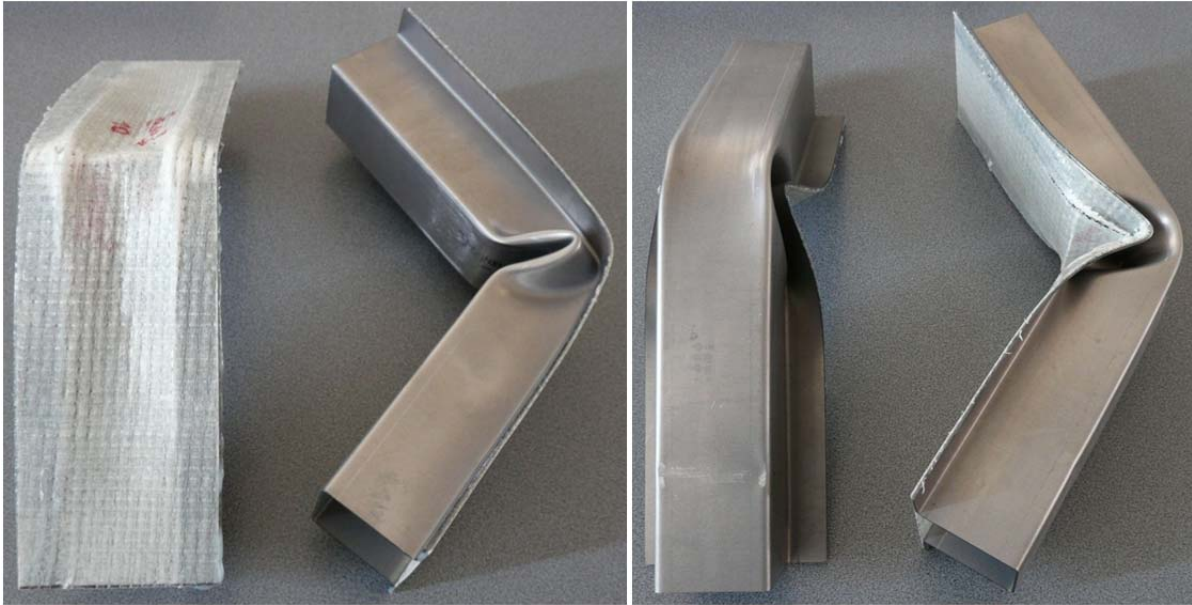

Figure 9: hybrid specimens after the test; on the left composite plate on the top, on the right composite plate in bottom position

In figure 10 for some of the performed bending tests, the histories of the longitudinal and transversal strains are reported together with the applied load. It is well visible that for the beam with the composite plate at the upper surface (black curves) both the longitudinal and the transverse strains are positive and their trends are characterised by a progressive decrease that becomes much more evident when the section collapse takes places. This change of slope in the strain curves is related to the formation of the two hinges. Vice versa for the beams with the composite plate at the bottom surface (grey curves), the longitudinal and transversal strains have opposite signs, being the longitudinal strain tensile (positive) and the transversal strain compressive (negative). Further it is well visible that the longitudinal strain trend is related to the applied force diagram, while the transverse strain is determined by the Poisson effect up to the plate collapse, when it starts to increase rapidly.

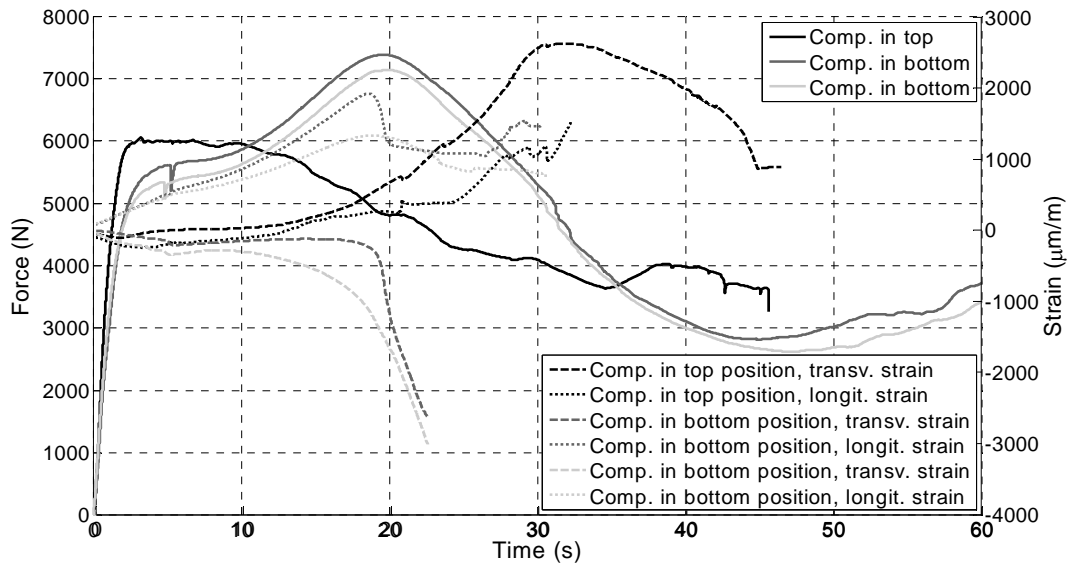

Figure 10: force and strain curves vs. stroke for the different hybrid specimens

### 3.2 Metallic specimens

The results of the different tests made on the metallic specimens joined by structural adhesive are shown in figure 11 for the force-displacement behaviour. In figure 12 there are some pictures of the specimens after the tests..

The collapse develops according to the Kecman model [26, 27]: a bulge comes out from each of the two lateral sides and a fold develop on the top (compression surface). The formation of this plastic hinge determines the large progressive decrease of the bending load-carrying capacity of the beam. Thanks to the contribution of structural adhesive the solutions with the plate in top positions have shown the highest values of stiffness and elastic limit. After the first load peak, this solution is characterised by a progressive slightly decrease of the load, ensuring also the highest values of absorbed energy.

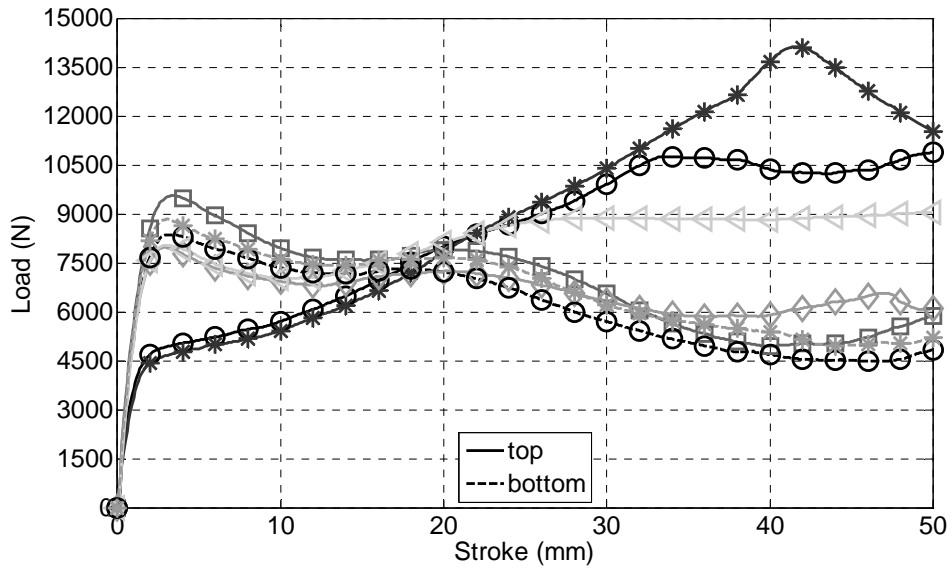

Figure 11: force-displacement curves for the metal specimens joined by structural adhesive



Figure 12: metal specimens joined by adhesive after the test; on the left plate on the top, on the right plate in bottom position

The results of the different tests made on the other type of metal specimen joined by spot welding are shown in figure 13 for the force-displacement behaviour. In figure 14 there are some pictures of the specimens after the tests.

In the solution with the plate in the bottom position, the behaviour is the same as illustrated before for the other type of metallic specimens, with the creation of a plastic hinge. Different behaviour is obtained for the second solution with the plate in the top position. A yielding in the side walls of the specimen takes place and the plate assumes the shape of the punch. This behaviour brings to continuous increase of the load also after the first peak, so the force displacement curves of these solutions show the same trend of the solution with the plate in the opposite side. The elastic limit and the stiffness have been lower in average than the other two solutions. The energy absorbed is very similar to that of the other metal specimens.

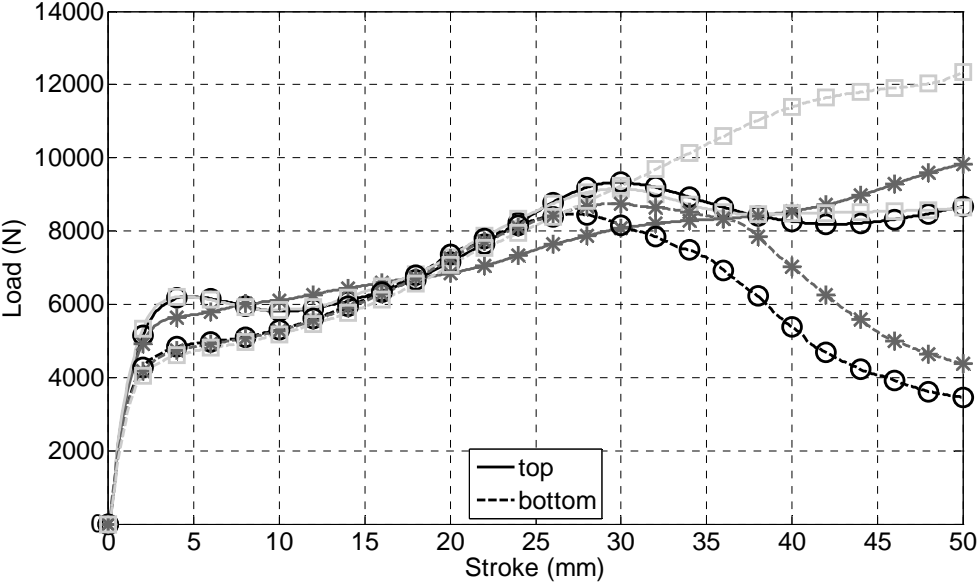

Figure 13: force-displacement curves for the metal specimens joined by spot weld



Figure 14: metal specimens joined by spot welding after the test; on the left plate on the top, on the right plate in bottom position

#### **4 Discussion of the results and conclusions**

The structural behaviour of hybrid box beams has been investigated by means of a series of three points bending tests in quasi static loading condition.

The examined cross section is that typically used in automotive constructions, and in particular the top-hat section. Three different types of specimen have been examined the first one has been made in hybrid way using steel for the hat part and fibre reinforced composite for the plate part. The joint between the hat and the plate parts has been made of structural adhesive. The second one has been completely made of steel and the joining between the two parts has been made with adhesive, once again. Finally the third type has been completely made in steel but the joining between plate and hat has been made with spot welding.

The results of experimental three points bending test are summarized in terms of force-displacement curves. From these curves the parameters of stiffness, elastic limit, and maximum load have been obtained. Also the post buckling behaviour has been examined.

The work put clearly in evidence the advantages obtainable by the use of adhesives.



First of all, the adhesive makes it possible to build the hybrid specimens which leads to a consistent weight reduction of about 28% and behaves better than whole metallic columns in terms of stiffness and elastic limit if we consider the solution with the plate in the bottom position.

Moreover, considering the stiffness and the elastic limit (figure 6) that are the most interesting parameters for the design of this type of structure, the hybrid solution, in both the considered load cases, behaves better than metallic one with spot weld, that is the reference solution.

Further, looking at the results in terms of specific absorbed energy, the hybrid solution are the most interesting one, the curves shown in figures 5 for the hybrid composite solution, are the highest ones on the right of the diagrams, that is at the end of the tests.

Finally, as expected, the advantages of adhesive joining solution clearly emerges also in the whole metallic case, which exhibits the highest value of stiffness, elastic limit and absorbed energy with respect to the spot welded solution.

## References

- [1] J. Dings, Reducing CO<sub>2</sub> emissions from new cars: a study of major car manufacturers, progress in 2007, European federation for transport and environment AiSBL, Brussels, 2008.
- [2] Average carbon dioxide emissions resulting from gasoline and diesel fuel, Environmental protection agency office of transportation and air quality, Washington, U.S. 2005.
- [3] EU energy and transport in figures-Statistical pocketbook 2007/2008, Office for official publications of the European Communities, Luxembourg, 2008.
- [4] M. Peden, World report on road traffic injury prevention: summary, World health organization, Geneve, 2004.
- [5] B. Friedel, D. Cesari, European Enhanced Vehicle Safety Committee-Status report for the 18<sup>th</sup> ESV coferece, proc. of the 18<sup>th</sup> ESV int. conf., Nagoya, 2003.
- [6] M. Kuehn, R. Froeming, V. Schindler, Assessment of vehicle related pedestrian safety, proc. of the 19<sup>th</sup> ESV int. conf., Washington, 2005.
- [7] W. Koch, M. Howard, Comprehensive approach to increased pedestrian safety, ATZ worldwide, 105, (January 2003), 20-23.

- [8] C.E. Neal-Sturgess, et al., APROSYS European in-depth pedestrian database, proc. of the 20<sup>th</sup> ESV int. conf., Lyon, 2007.
- [9] G. Davies, Materials for automobile bodies, Elsevier, Oxford, 2003.
- [10] G. Belingardi, M. Avalle, Advanced materials for automotive applications Mobil. Veh. Mech., 30, 2-3, (2004), 51–65.
- [11] Future automotive materials assessment (5, 10, 15 year outlook), Frost & Sullivan, 2006.
- [12] K.L. Edwards, Strategic substitution of new materials for old: applications in automotive product development. Mater. & Des., 25, (2004), 529-533.
- [13] Advances in automotive plastics, Frost & Sullivan, 2007.
- [14] E. Wall, et al., Progress report for automotive lightweighting materials I & II, Energy efficiency and renewable energy, Washington, 2007.
- [15] P.F. Krajewski, A.T. Morales, Materials for automotive and ground vehicles, ASM Int. J. of Mater. Eng. and Perform., 2008.
- [16] Lightweight materials for automotive applications, Frost & Sullivan, 2005.
- [17] N. Trucker, K. Lindsey, An introduction to automotive composites. Rapra technology limited, UK, 2002.
- [18] C.A. Harper, Handbook of plastics, elastomers & composite, McGraw-Hill, 2002.
- [19] R. Schönfeld, Crash resistant structural bonding, proc. of the workshop on structural adhesives, Politecnico di Torino, Vercelli, 2006.
- [20] M. Avalle, Experimental comparison of different innovative joining system for thin walled structures, proc. of the 12<sup>th</sup> int. conf. on exp. mech. (ICEM12): Advances in Experimental Mechanics, McGraw-Hill, Bari, 2004, Paper No. 253.
- [21] G. Belingardi, P. Martella, L. Peroni, Analisi del comportamento flessionale di profilati scatolati, saldati a punti, proc. of the XXXIV AIAS national conference, Milan, 2005
- [22] S. J. Cimpoeru, N. W. Murray, The large deflection pure bending properties of a square thin-walled tube, In Int. J. of Mech. Sci. 35, pp.247-256, 1993.
- [23] Brown J. C., G. H. Tidbury, An investigation of the collapse of thin-walled rectangular beams in biaxial bending, Int. J. Mech. Sciences, pp. 733-746, 1983.

- [24] Peroni L., Belingardi G., Studio del collasso flessionale di profilati in parete sottile sottoposti a flessione deviata, XXX AIAS national conference, Alghero 2001.[25] Peroni L., Belingardi G., Indagine sperimentale sul collasso plastico flessionale di strutture in parete sottile, XXXII AIAS national conference, Salerno 2003.
- [26] D. Kecman, Bending collapse of rectangular and square section tubes, *Int. J. of Mech. Sci.*, 25, (1983) 623-636.
- [27] M. Avalle, G. Belingardi, R. Montanini, Strain field measurements in the bending collapse of thin-walled tubes, *proc. of the 11<sup>th</sup> int. conf. on experimental mechanics ICEM*, Oxford (UK) 24-28 August 1998, 245-250.
- [28] L. Peroni, M. Avalle, G. Belingardi, Comparison of the energy absorption capability of crash boxes assembled by spot-weld and continuous joining techniques, *Int. J. of Imp. Eng.*, 36 (3) 498-511 (2009).
- [29] L. Goglio, L. Peroni, M. Peroni, M. Rossetto, High strain-rate compression and tension behaviour of an epoxy bi-component adhesive, *Int. J. of Adhes. and Adhes.*, 28 (7) 329-339.